

NOTES:

1. MEANDER SIDEWALK AROUND MAILBOX TO MAINTAIN FULL WIDTH OF SIDEWALK.
2. COORDINATE MAILBOX LOCATION WITH LOCAL POSTMASTER AND ENSURE MAILBOX SHALL NOT IMPACT SIGHT LINES.
3. ADDITIONAL REQUIREMENTS PER REVIEW ENGINEER FOR INSTALLATION ALONG ARTERIAL STREETS.
4. FOR USE WITH USPS APPROVED MAILBOXES ONLY.
5. ANCHOR BOLTS SHALL BE CUT FLUSH TO MOUNTING SURFACE.
6. ALL SIDEWALK INSTALLED PER C.O.B. STD. DWG. SW-110-1.
7. FOR INSTALLATION AT LOCATION WITHOUT CURB, TOP OF CONCRETE PAD SHALL BE FLUSH WITH GROUND SURFACE. PLACEMENT SHALL BE APPROVED IN ADVANCE BY REVIEW ENGINEER.

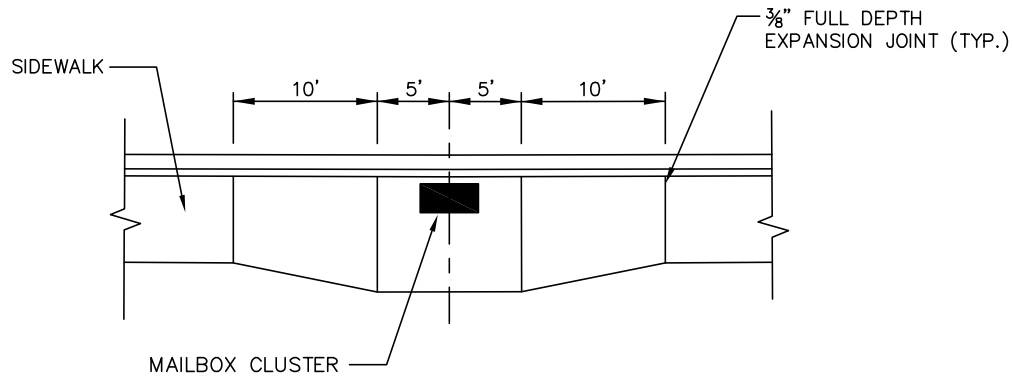

SIDEWALK TRANSITION DETAIL
NTS

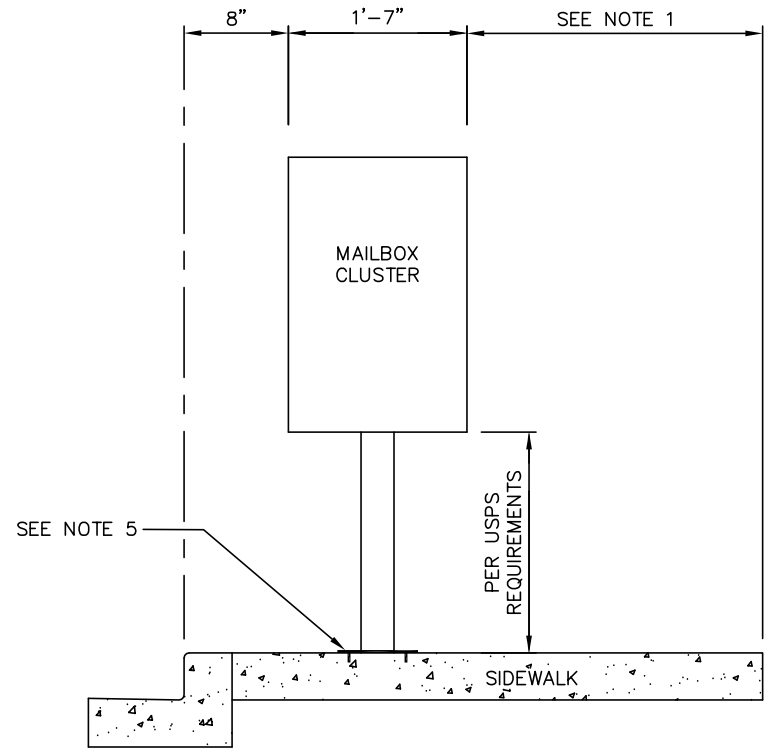

SECTION
NTS



CLUSTER MAILBOX DETAIL

DRAWING NUMBER	RC-280-1
SCALE	NONE
REVISION DATE	12/16
DEPARTMENT	TRANS