

APPENDIX A

PRELIMINARY DRAWINGS

West Tie-In Structure Plaza Extension

City Hall Plaza

City Hall Plaza Extension

Downtown Bellevue Sound Transit Station

GCC West Tie-In Structure

West Tie-In Structure CIP PT Box Girder

City Hall Plaza

Downtown Bellevue Sound
Transit Station

GCC West
Tie-In Structure

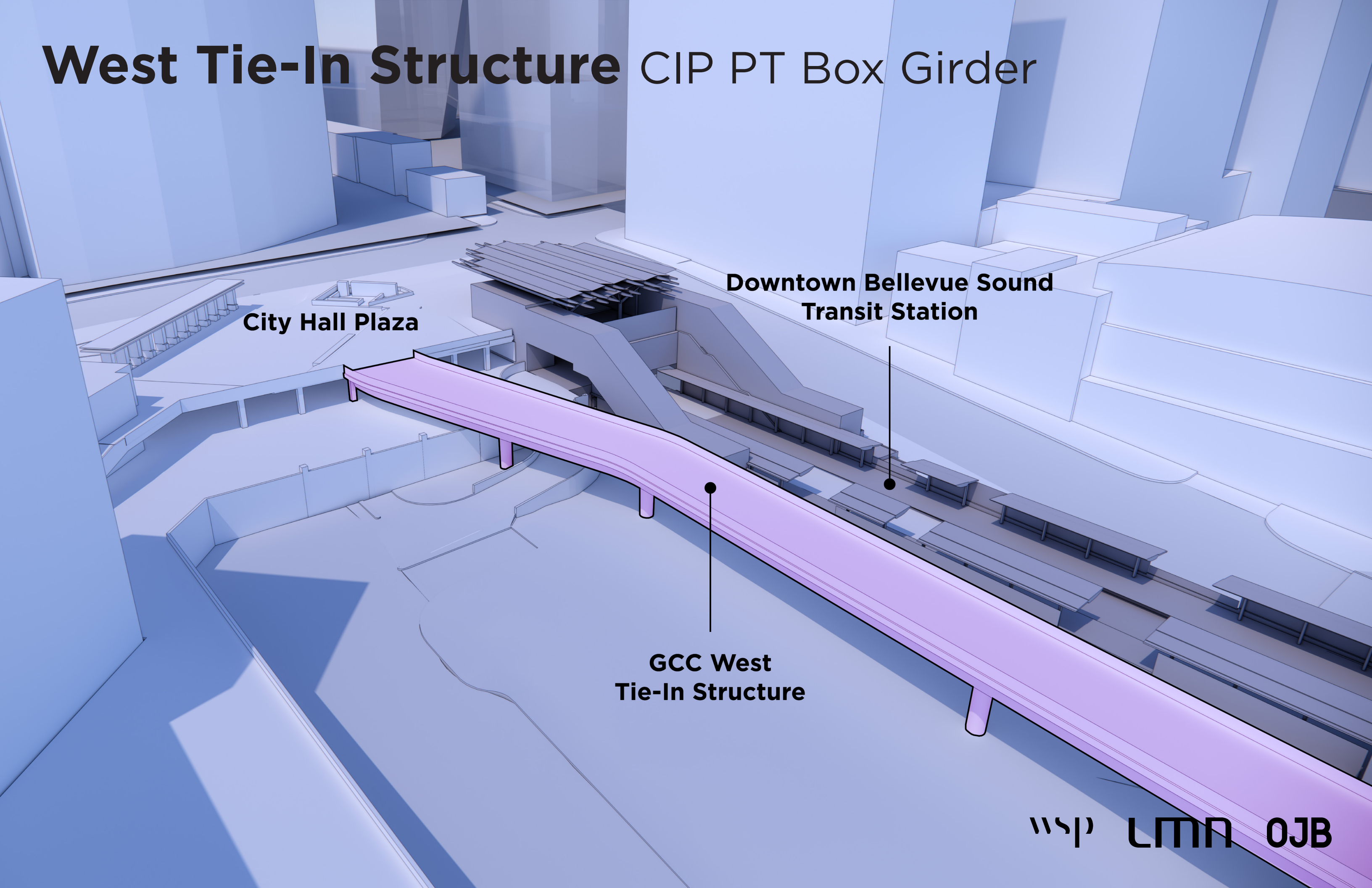

West Tie-In Structure Cable Stayed Cantilever

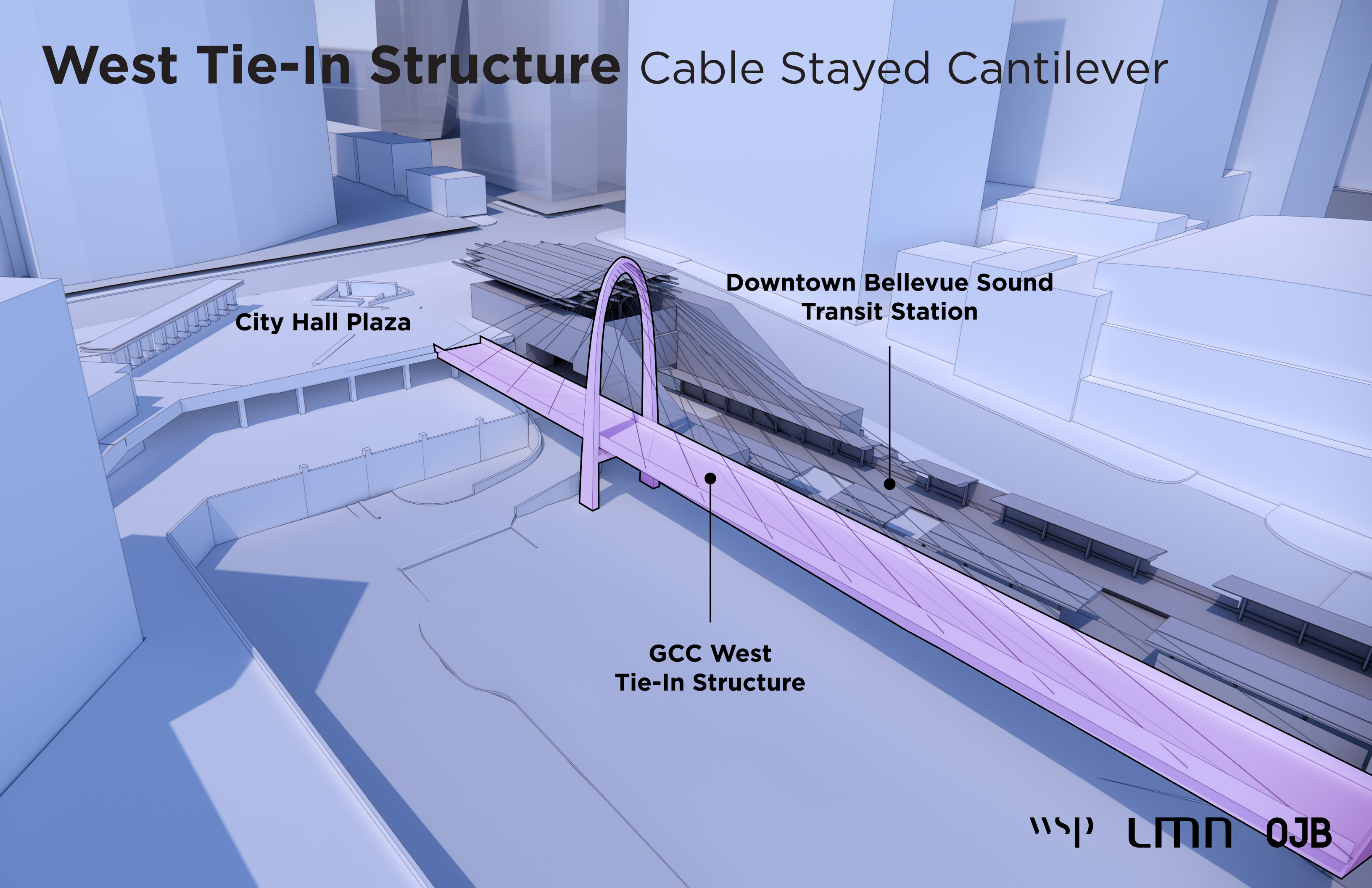

City Hall Plaza

**Downtown Bellevue Sound
Transit Station**

**GCC West
Tie-In Structure**

West Tie-In Structure Steel Truss Cantilever

City Hall Plaza

Downtown Bellevue Sound
Transit Station

GCC West
Tie-In Structure

WSP | LMN | OJB

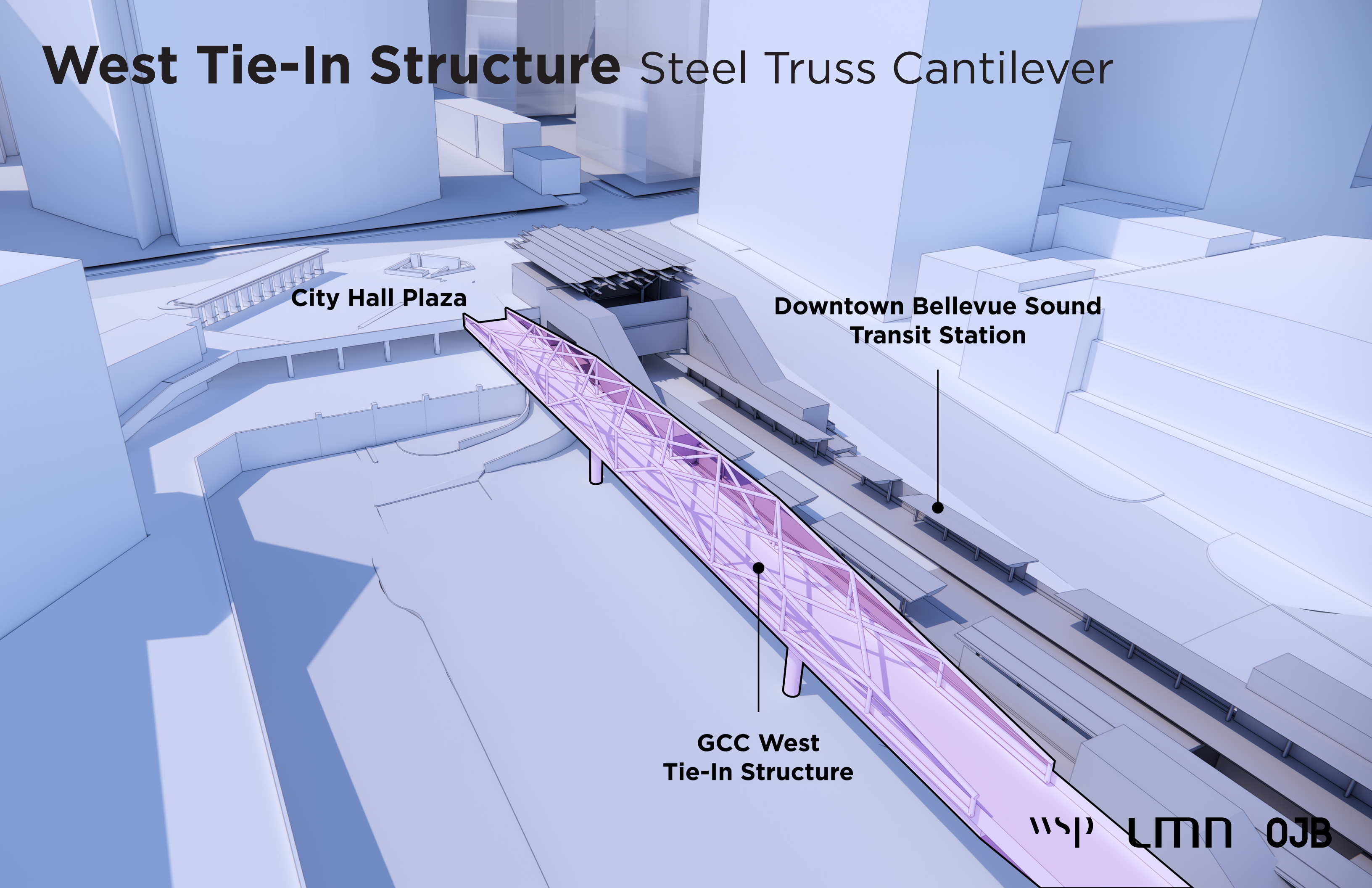

West Node

NE 8th St.

I-405 NB

I-405 SB

Sound Transit
Guideway

Downtown Bellevue Sound
Transit Station

NE 6th St.

GCC West Node

GCC West
Tie-In Structure

112th Ave. NE

WSP LMK OJB

West Node

Sound Transit
Guideway

112th Ave. NE

WSP

LMN

OJB

I-405 Arch

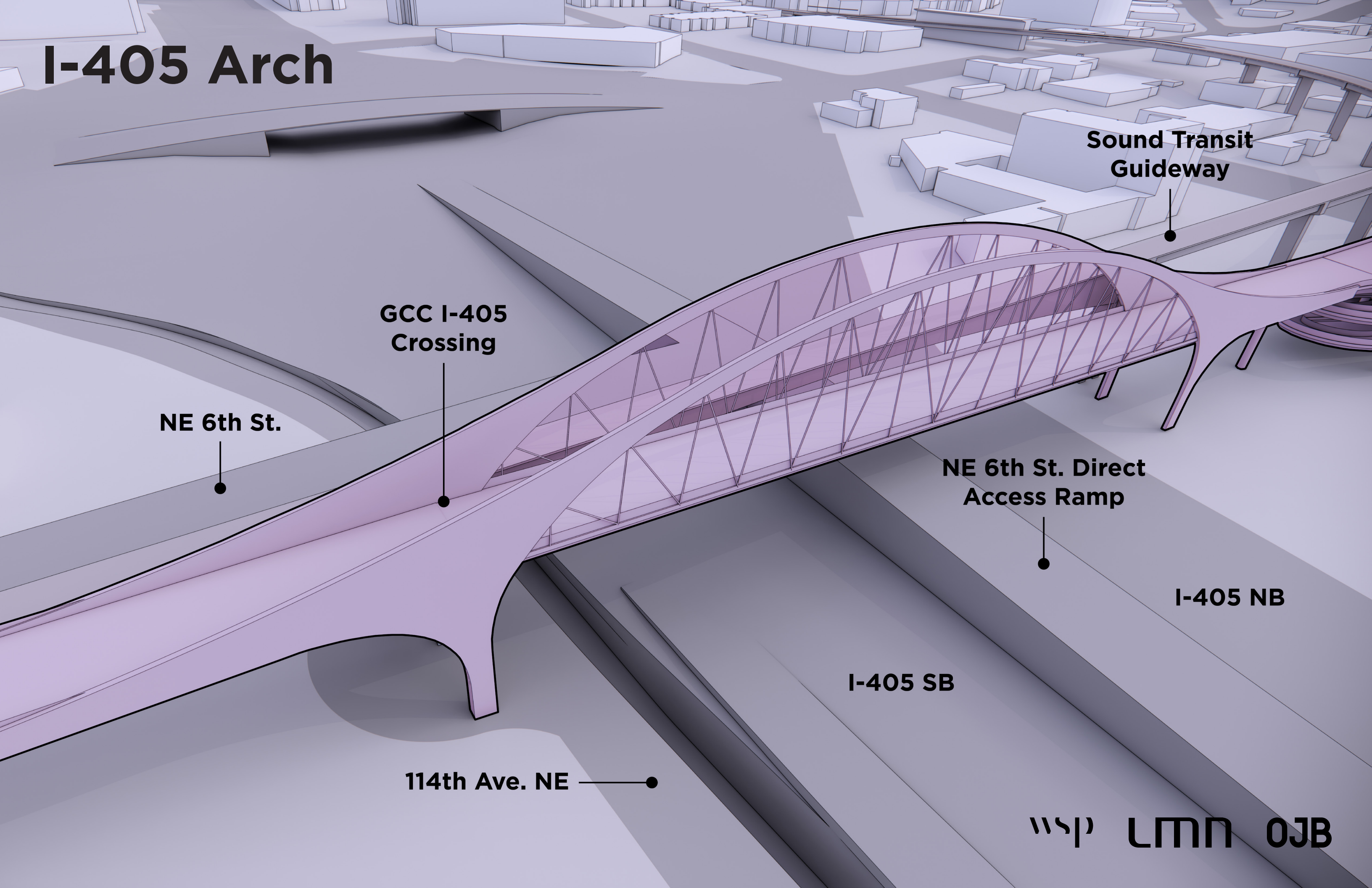

Sound Transit
Guideway

GCC I-405
Crossing

NE 6th St.

NE 6th St. Direct
Access Ramp

I-405 NB

I-405 SB

114th Ave. NE

WSP LHM OJB

I-405 Truss

NE 8th St.

GCC I-405
Crossing

Sound Transit
Guideway

NE 6th St.

NE 6th St. Direct
Access Ramp

I-405 NB

I-405 SB

114th Ave. NE

WSP LHM OJB

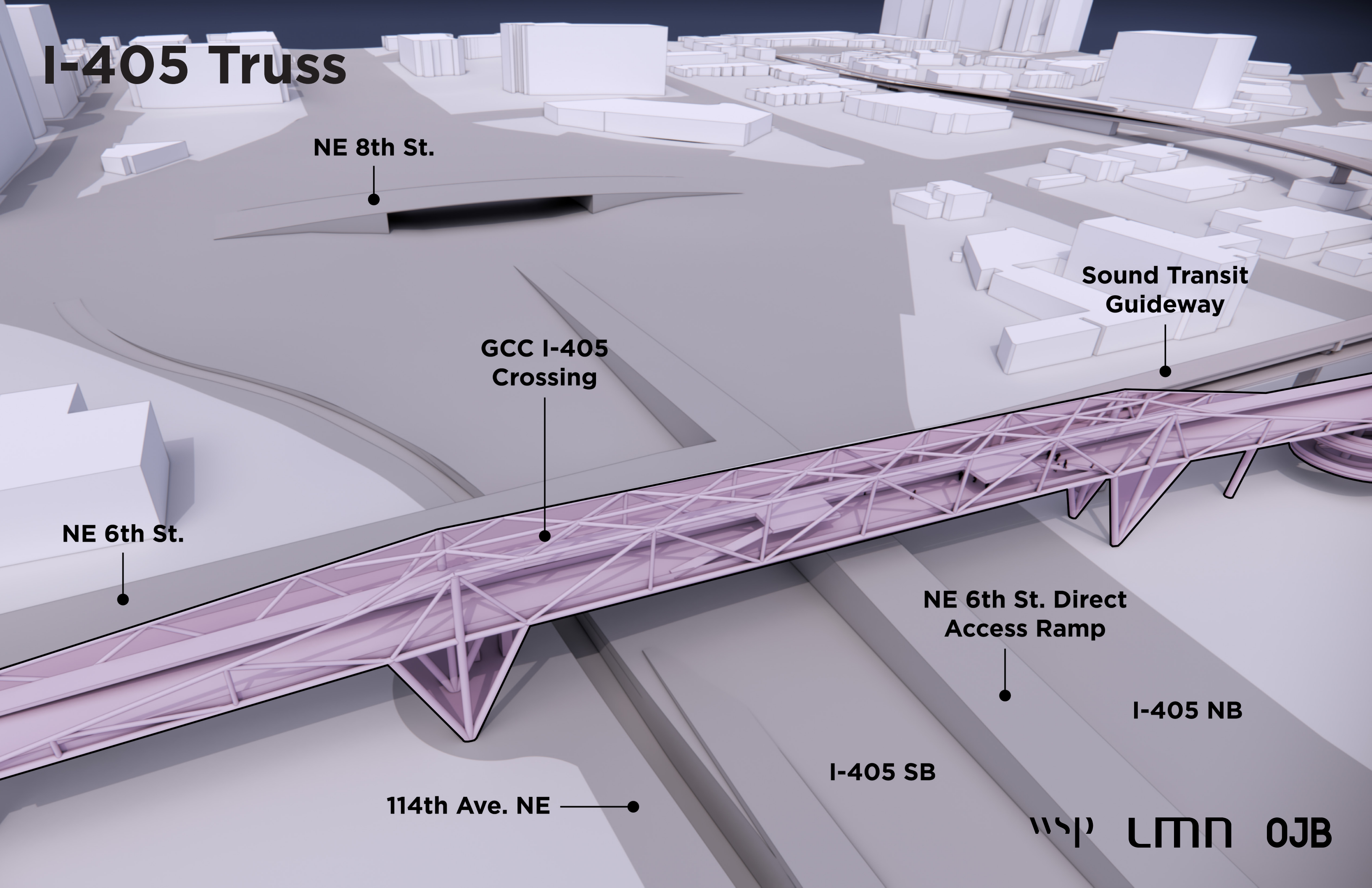

I-405 Girder

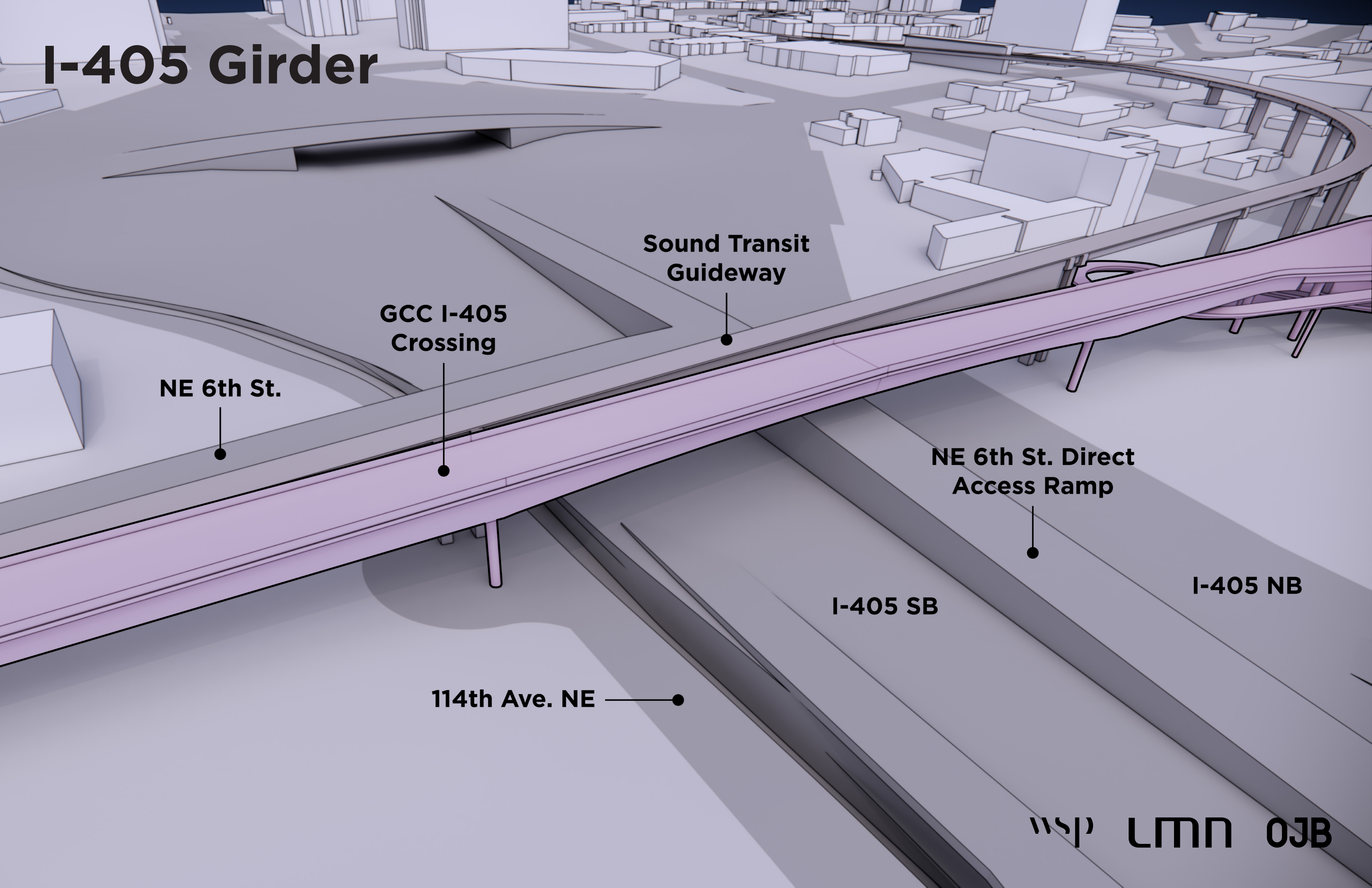

NE 6th St.

GCC I-405 Crossing

Sound Transit Guideway

NE 6th St. Direct Access Ramp

I-405 SB

I-405 NB

114th Ave. NE

East Node

Sound Transit
Guideway

GCC East Node

GCC Eastrail
Tie-In Structure

116th Ave. NE

East Node

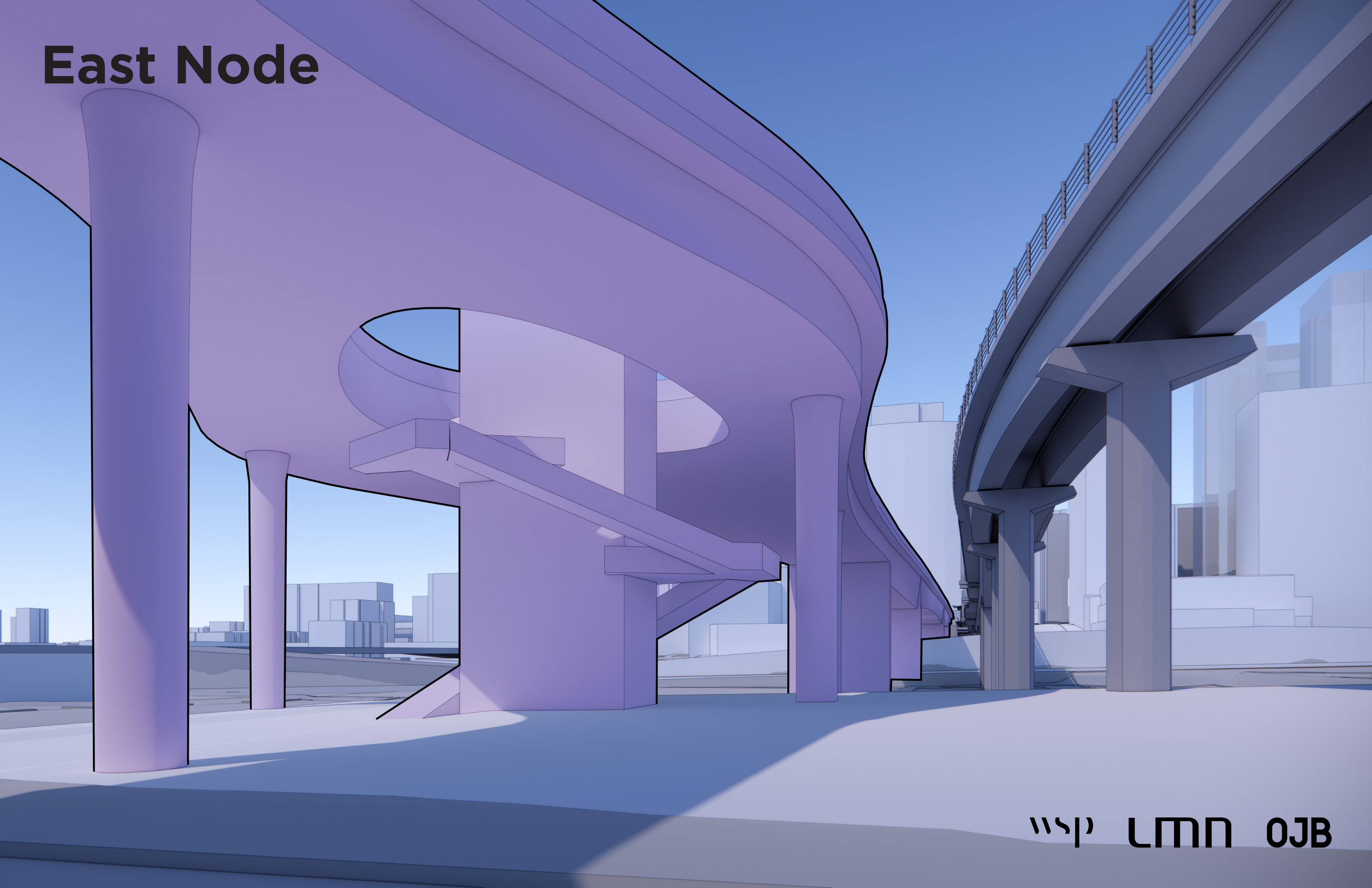

East Node

NE 8th St.

Sound Transit
Guideway

Eastrail

GCC Eastrail
Tie-In Structure

116th Ave. NE

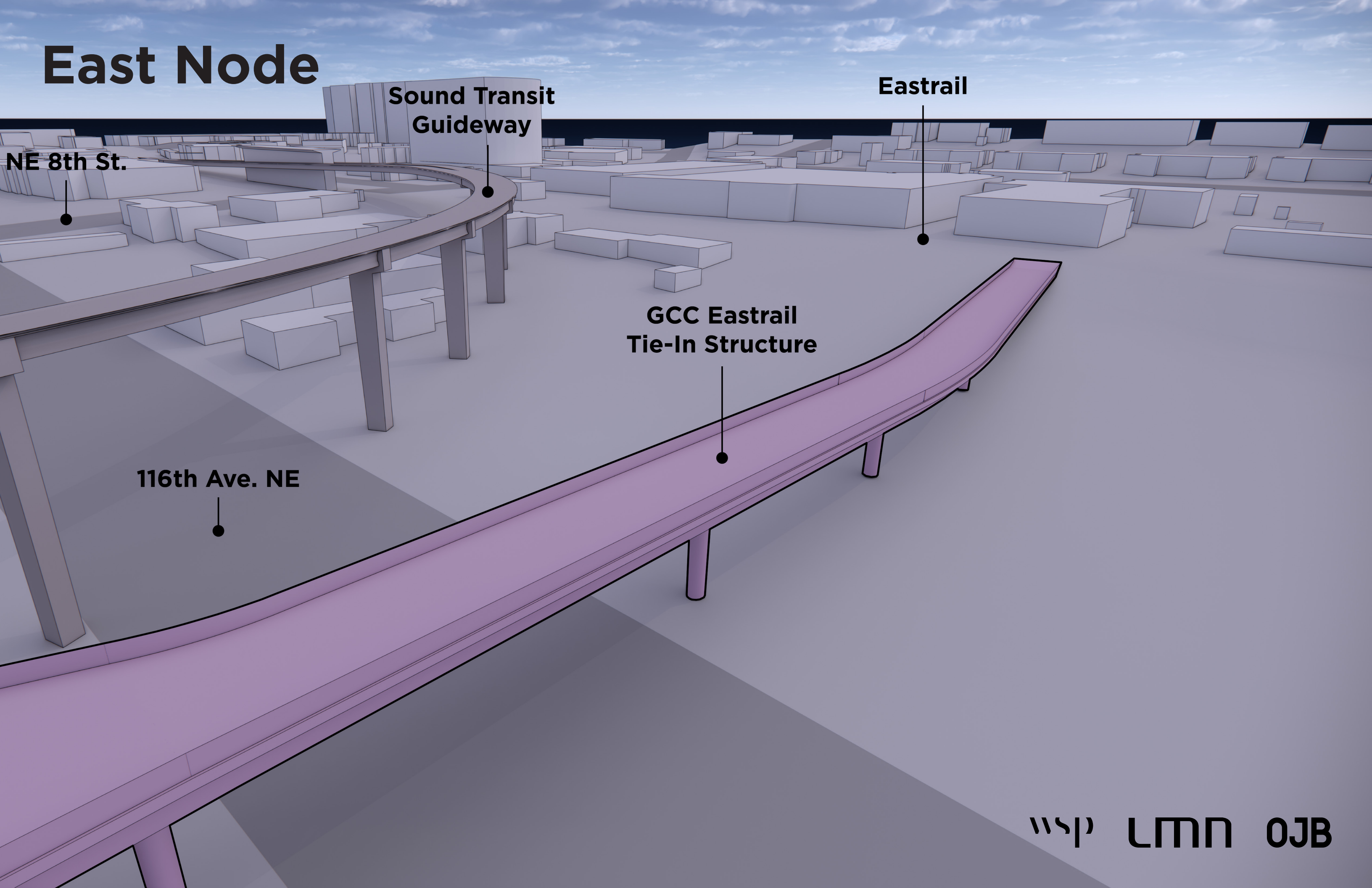

SCHEME OVERALL PLAN | TRUSS

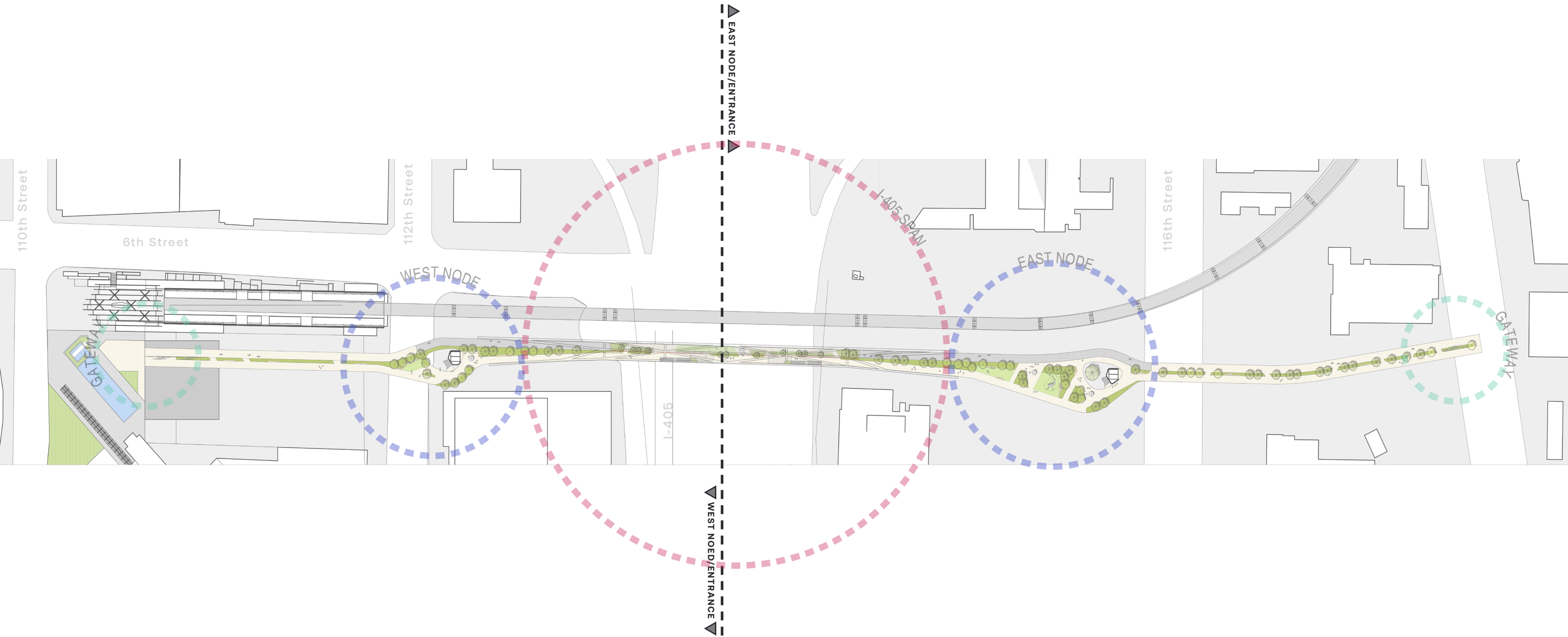

SCHEME PLAN | TRUSS

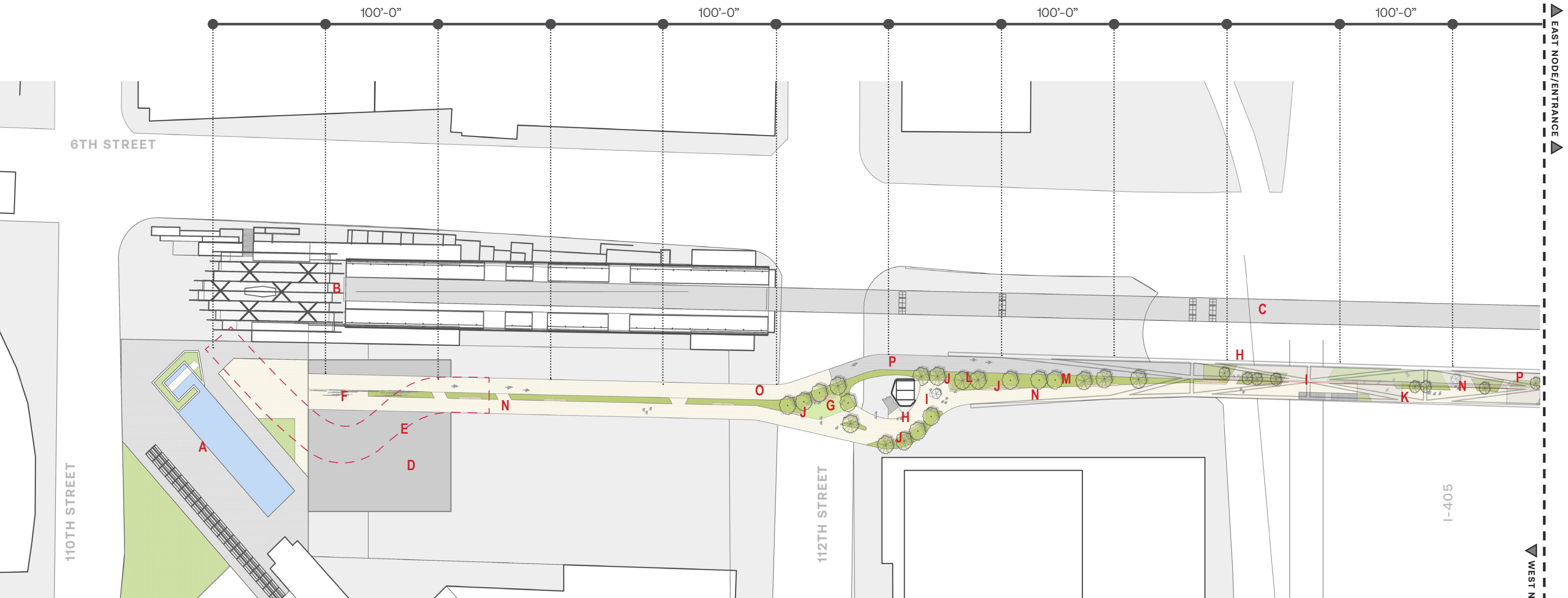

LEGEND

- | | |
|---|-------------------------------------|
| A City Hall Plaza | I Open Space |
| B Downtown Sound Transit Station | J Lounge Space |
| C Sound Transit Guideway | K Viewpoint Outlook |
| D Existing Plaza Expansion | L Canopy Tree |
| E Alternate West Tie-In | M Raised Ornamental Planting |
| F Art Moment | N Pedestrian Path |
| G Turf Area | O Bike Path |
| H Vertical Circulation & Entry Plaza | P Upper Bike Path |



SCHEME PLAN | TRUSS

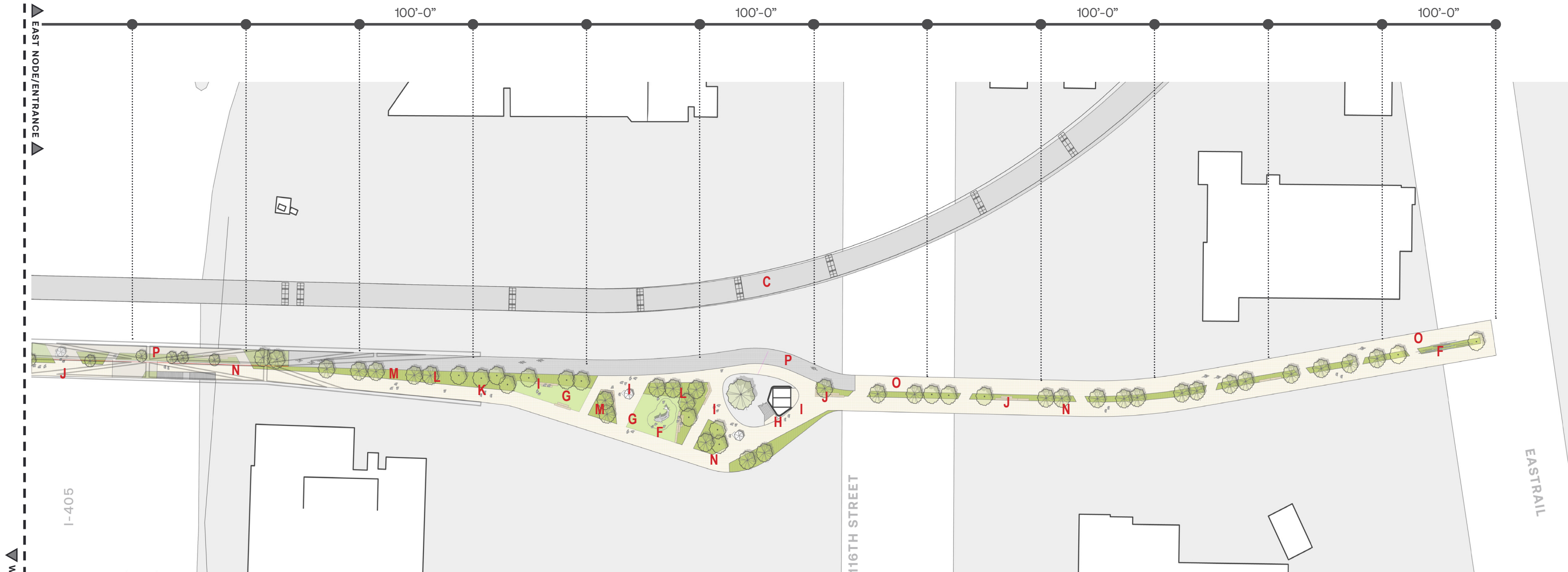

LEGEND

- | | |
|---|-------------------------------------|
| A City Hall Plaza | I Open Space |
| B Downtown Sound Transit Station | J Lounge Space |
| C Sound Transit Guideway | K Viewpoint Outlook |
| D Existing Plaza Expansion | L Canopy Tree |
| E Alternate West Tie-In | M Raised Ornamental Planting |
| F Art Moment | N Pedestrian Path |
| G Turf Area | O Bike Path |
| H Vertical Circulation & Entry Plaza | P Upper Bike Path |

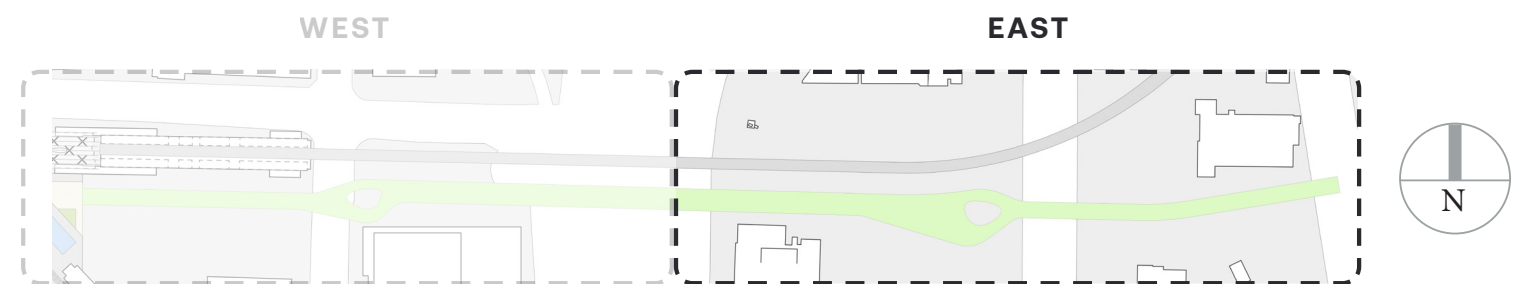

SCHEME OVERALL PLAN | ARCH

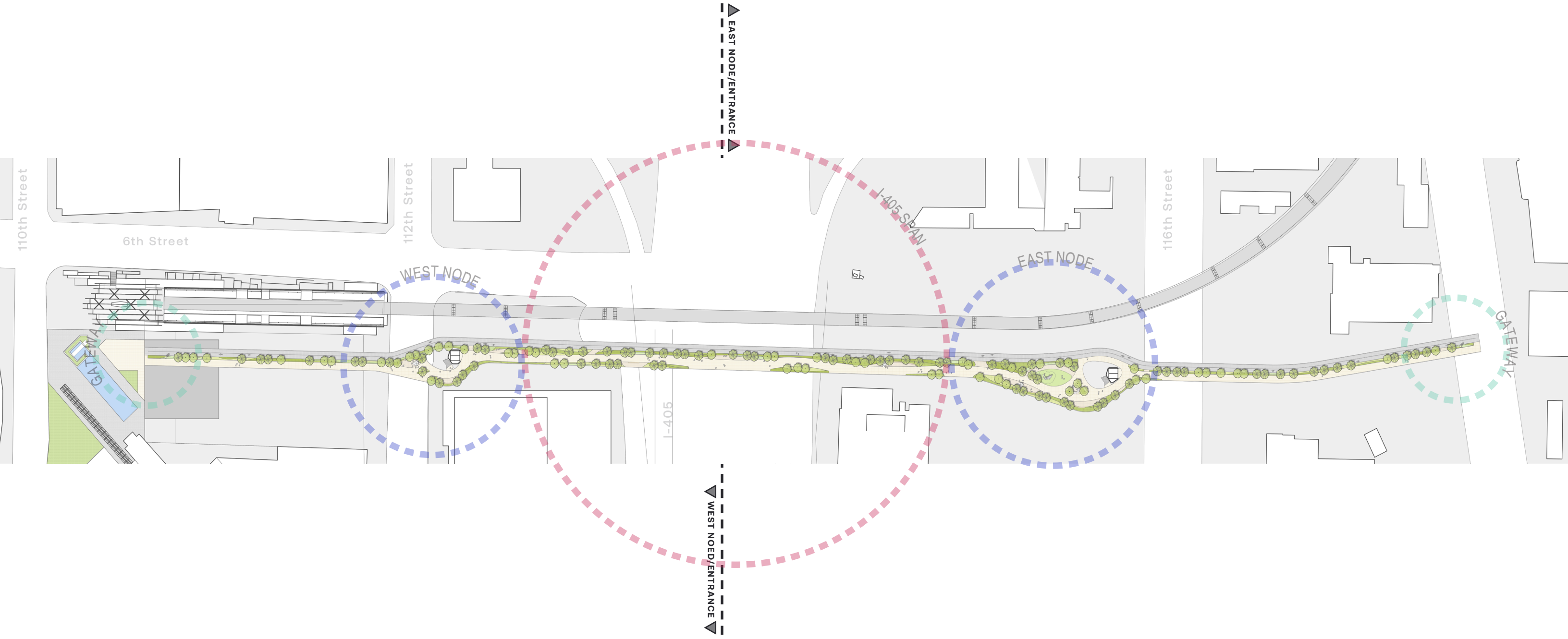

SCHEME PLAN | ARCH



LEGEND

- | | |
|---|-------------------------------------|
| A City Hall Plaza | I Open Space |
| B Downtown Sound Transit Station | J Lounge Space |
| C Sound Transit Guideway | K Viewpoint Outlook |
| D Existing Plaza Expansion | L Canopy Tree |
| E Alternate West Tie-In | M Raised Ornamental Planting |
| F Art Moment | N Pedestrian Path |
| G Turf Area | O Bike Path |
| H Vertical Circulation & Entry Plaza | |

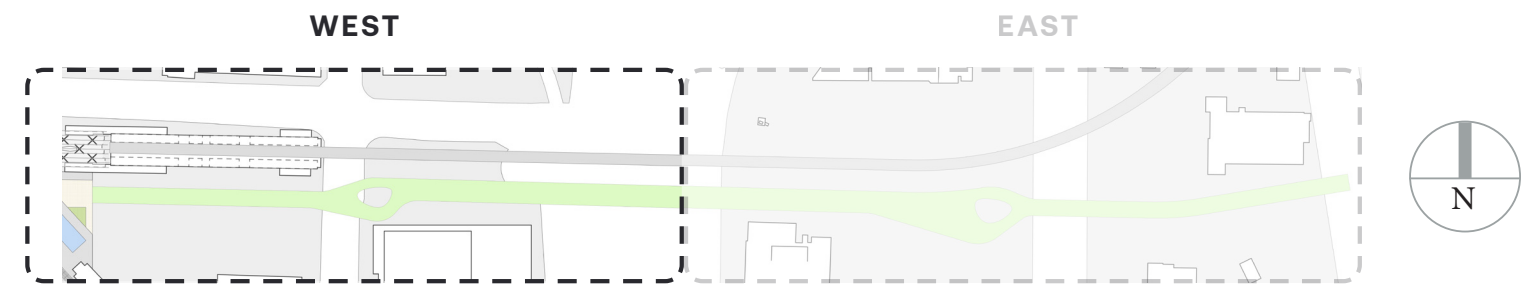

SCHEME PLAN | ARCH



LEGEND

- | | |
|---|-------------------------------------|
| A City Hall Plaza | I Open Space |
| B Downtown Sound Transit Station | J Lounge Space |
| C Sound Transit Guideway | K Viewpoint Outlook |
| D Existing Plaza Expansion | L Canopy Tree |
| E Alternate West Tie-In | M Raised Ornamental Planting |
| F Art Moment | N Pedestrian Path |
| G Turf Area | O Bike Path |
| H Vertical Circulation & Entry Plaza | |

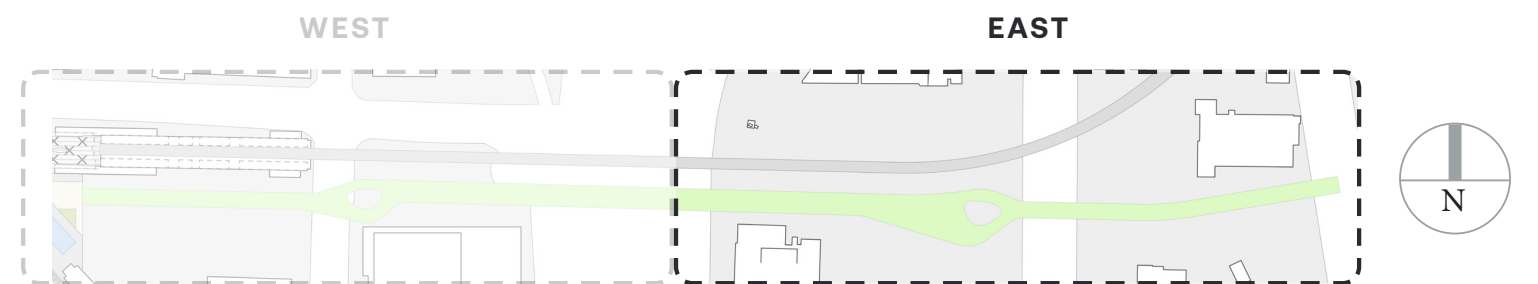

SCHEME OVERALL PLAN | CAST-IN-PLACE, POST TENSION CONCRETE GIRDER

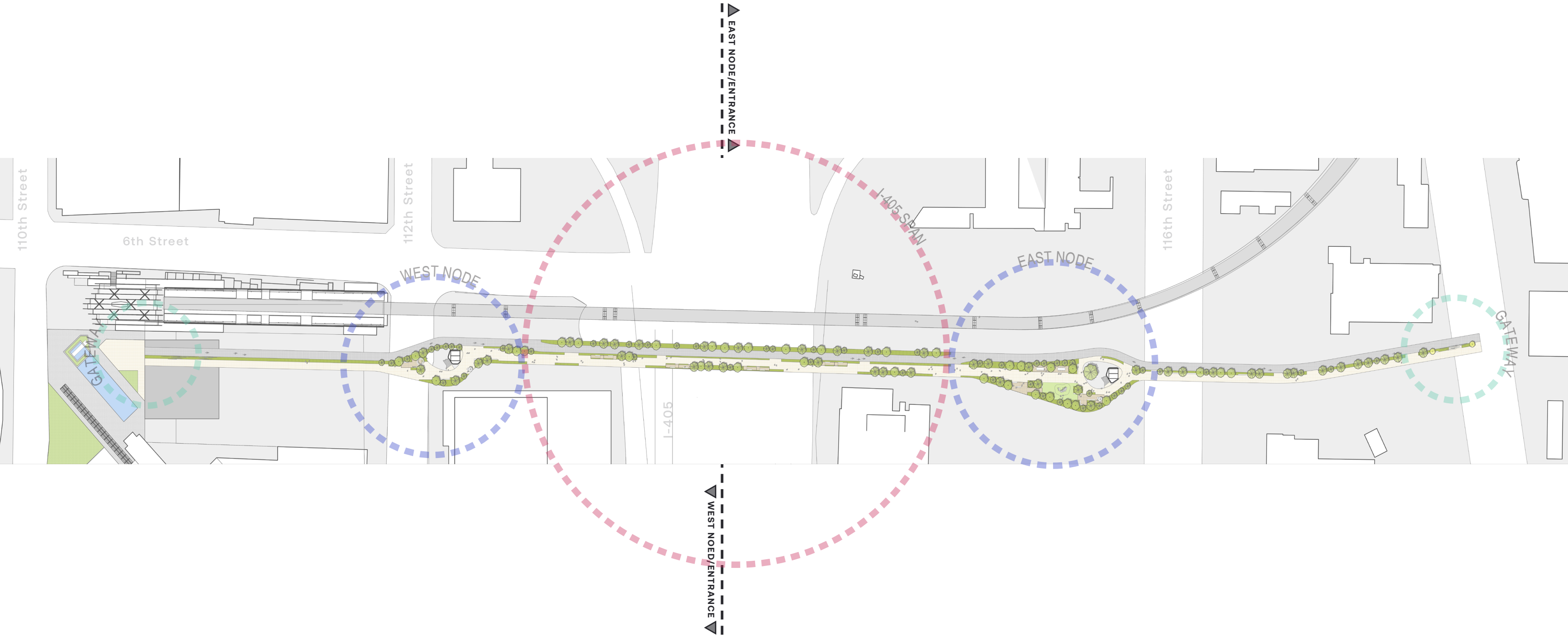

SCHEME PLAN | CAST-IN-PLACE, POST TENSION CONCRETE GIRDER



LEGEND

- | | |
|---|-------------------------------------|
| A City Hall Plaza | I Open Space |
| B Downtown Sound Transit Station | J Lounge Space |
| C Sound Transit Guideway | K Viewpoint Outlook |
| D Existing Plaza Expansion | L Canopy Tree |
| E Alternate West Tie-In | M Raised Ornamental Planting |
| F Art Moment | N Pedestrian Path |
| G Turf Area | O Bike Path |
| H Vertical Circulation & Entry Plaza | |



SCHEME PLAN | CAST-IN-PLACE, POST TENSION CONCRETE GIRDER



LEGEND

- | | |
|---|-------------------------------------|
| A City Hall Plaza | I Open Space |
| B Downtown Sound Transit Station | J Lounge Space |
| C Sound Transit Guideway | K Viewpoint Outlook |
| D Existing Plaza Expansion | L Canopy Tree |
| E Alternate West Tie-In | M Raised Ornamental Planting |
| F Art Moment | N Pedestrian Path |
| G Turf Area | O Bike Path |
| H Vertical Circulation & Entry Plaza | |

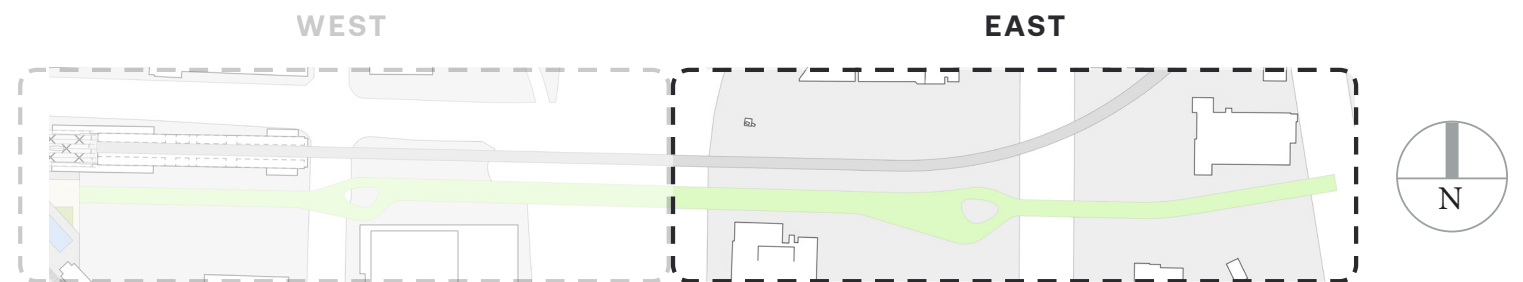

HARDSCAPE MATERIAL & SITE AMENITIES

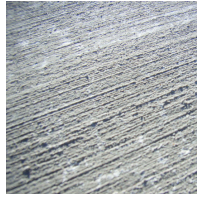

BIKE LANE PAVING - BRIDGE DECKING CAST-IN-PLACE CONCRETE, NATURAL GREY COLOR, PATH DEMARCATIONS (LANE DELINIATION AND BIKE-LANE SYMBOLS), MEDIUM BROOM FINISH



SPECIAL SEATING - CAST-IN-PLACE CONCRETE SEATING, INTEGRAL COLOR TBD, EXPOSED AGGREGATE



LITTER RECEPTACLE - 'TRIPLE' RECEPTACLE FOR SORTING PAPER, PLASTIC AND LANDFILL WASTE, INCLUDING COVER, SURFACE MOUNTED TO CONCRETE PAVING (CRYSTAL - CS350x, MMCITE).



TRAIL ID & STATION/ZONE SIGNAGE - POWDERCOATED ALUMINUM PANEL ON SURFACE MOUNTED METAL POST



PEDESTRIAN PAVING - INTEGRAL COLORED CONCRETE PAVING, COLORS TBD, HEAVY & MEDIUM EXPOSED AGGREGATE FINISH, SAWCUT AND PATTERN PER PLAN OR 5' X 5'.

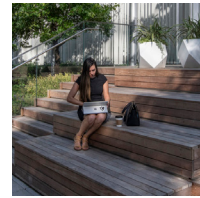

SPECIAL SEATING - CAST-IN-PLACE CONCRETE TIERED SEAT WALLS WITH 'THERMORY' WOOD SEAT TOPS.



BICYCLE PARKING - SURFACE MOUNTED TO CONCRETE PAVING (CAPITOL, FORMS + SURFACES).



BRANDING SIGNAGE- POWDERCOATED ALUMINUM PANEL ON SURFACE MOUNTED METAL POST



CONCRETE UNIT PAVER, SIZE (6" X 12") COLOR TBD, PATTERN TBD (WAUSAU). WITH REINFORCED CONCRETE SUBSLAB.

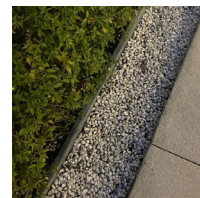

LOOSE STONE/GRAVEL - MAINTENANCE BANDS, 24" WIDE X 6" DEPTH, WITH 1/4" X 8" PAINTED METAL EDGING.



BICYCLE MAINTENANCE/REPAIR STATION - SURFACE MOUNTED TO CONCRETE PAVING, INCLUDING OUTDOOR PUBLIC WORK STAND & BIKE PUMP (SARIS INFRASTRUCTURE).



BRANDING SIGNAGE- PRE-WEATHERED STEEL PANEL WITH PIN MOUNTED BRUSHED STEEL LETTERS



FIXED METAL RAISED PLANTERS - PAINTED METAL CURBS AND WALLS ANCHORED CONCRETE BASE. HEIGHTS VARY FROM 6" TO 42" ABOVE FINISH GRADE.

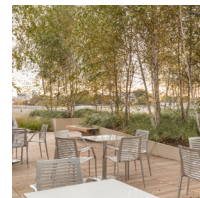

OUTDOOR DINING FURNITURE - MOVABLE BISTRO TABLES AND CHAIRS (LANDSCAPE FORMS).



PAVILION/ ARBOR SHADE STRUCTURE W/ HSS STEEL FRAME, STEEL CANOPY WITH WOOD OR STEEL LATTICE. POWDERCOATED FINISH.



INFORMATION KIOSK - CUSTOM WAYFINDING MAP AND GRAPHICS, LOCATED AT ENTRY POINTS, INCLUDING POWER AND DATA ACCESS REQUIRED FOR SIGNAGE

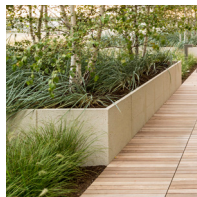

FIXED CONCRETE RAISED PLANTERS - CAST-IN-PLACE REINFORCED CONCRETE CURBS AND WALLS. HEIGHTS VARY FROM 6" TO 42" ABOVE FINISH GRADE.



DRINKING FOUNTAINS - ADA COMPLIANT WITH WATER BOTTLE REFILLER (ELKAY).



ENTRY/EXIT GATEWAY FEATURE - LOCATED AT CITY HALL PLAZA AND EASTRAIL AT-GRADE BRIDGE ENTRIES.



ENTRY POINT BRANDING DIRECTIONAL WAYFINDING SIGNAGE



VINE SUPPORT GROWTH STRUCTURE - FLEXIBLE 304 STAINLESS STEEL ROPE NETTING (JAKOB USA), ANCHORED TO CONCRETE AND STEEL BRIDGE STRUCTURAL ELEMENTS.



RETRACTABLE BOLLARDS W/ POWDERCOATED FINISH. INCLUDE ALL POWER REQUIRED FOR RETRACTABLE BOLLARDS.



SCULPTURAL PLAY ELEMENTS - INCLUDING Poured-IN-PLACE FALL SAFETY SURFACING (MONSTRUM OR KOMPAN)

IRRIGATION

Typical Irrigation System Controls

Irrigation Diagram

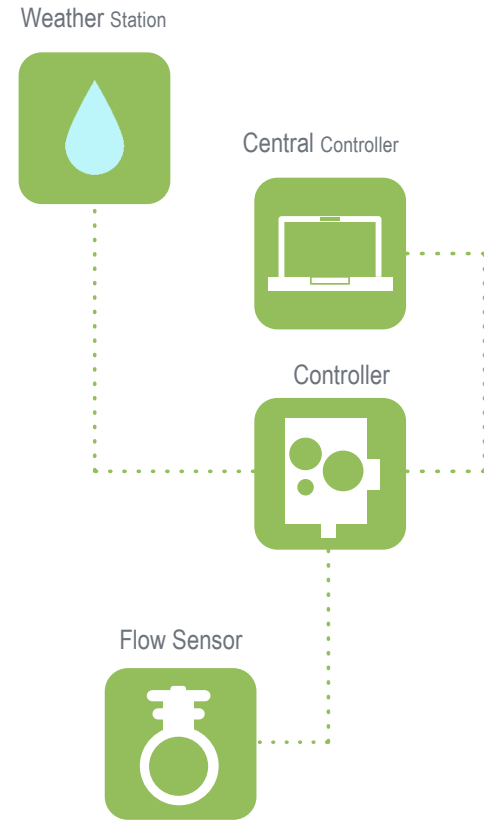

Weather Station

The Weather Station collects and stores weather data from field locations. This information is retrieved by the central controller daily, allowing Central Control Systems to adjust station runtimes according to each day's evapotranspiration and rainfall.

Central Controller

Automated evapotranspiration based irrigation control and the most flexible scheduling system allows control of multiple sites to exact specifications.



Flow Sensor

Flow sensor send flow data to central control or stand-alone controller systems for precise and accurate flow monitoring. Flow sensors enable you to capitalize on the advantages of Flow Management functionality.



Irrigation System Controls are controllers that automatically update the watering schedule to allow for changes in water needs throughout the year so it will automatically reduce the watering times as the weather gets cooler and less water is needed. Then as the weather begins to warm up, the controller will add more watering time. Set the controller for a default maximum watering time, based on the hottest time of year then the controller reduces that time amount by a percentage value when less water is needed.

Diagrammatic Irrigation System

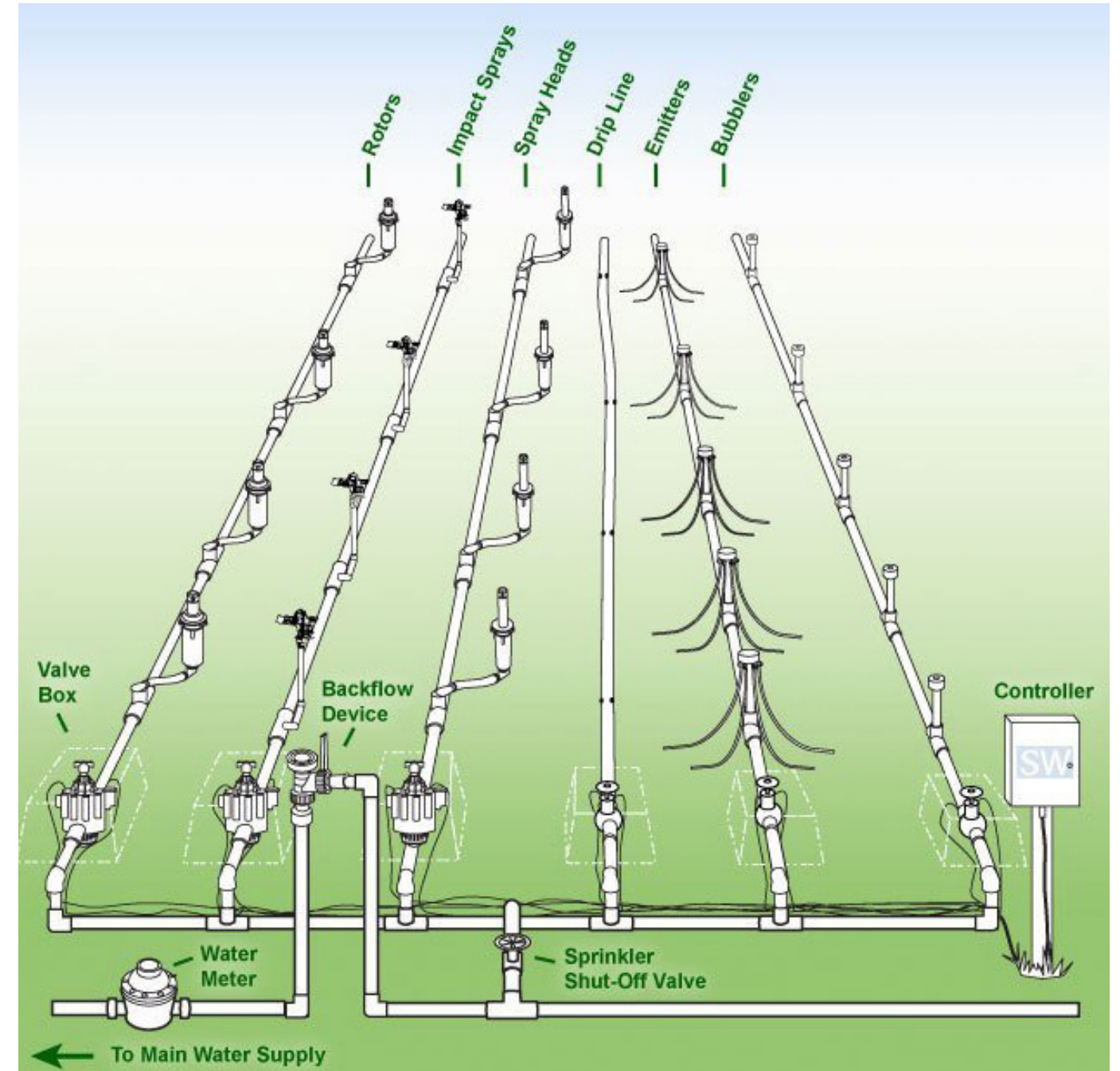

SITE ELECTRICAL

Typical Site Lighting

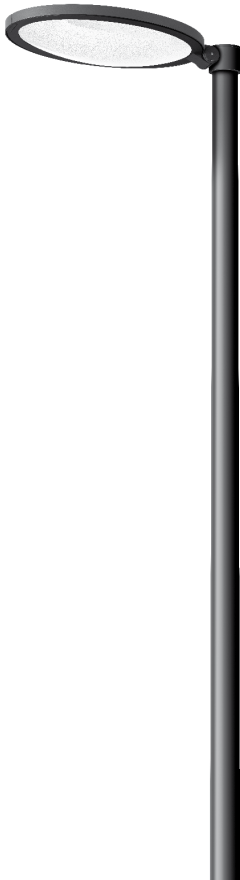

01 Street Light



02 Pedestrian Light



03 Pedestrian Down Light



04 Bollard



05 Tree Uplight



06 External Electrical Outlet



07 Wifi



Brochstein Pavilion Rice University

Landscape lighting has three basic functions, provide safety, security and aesthetics. Landscape lighting should provide a clear view of any potential objects in the environment. Lighting can increase a sense of security and comfort to outdoor spaces. Lighting exterior spaces can provide a view from the interior out into the landscape, highlight key elements in the landscape and accommodate activities such as entertainment and sporting events.

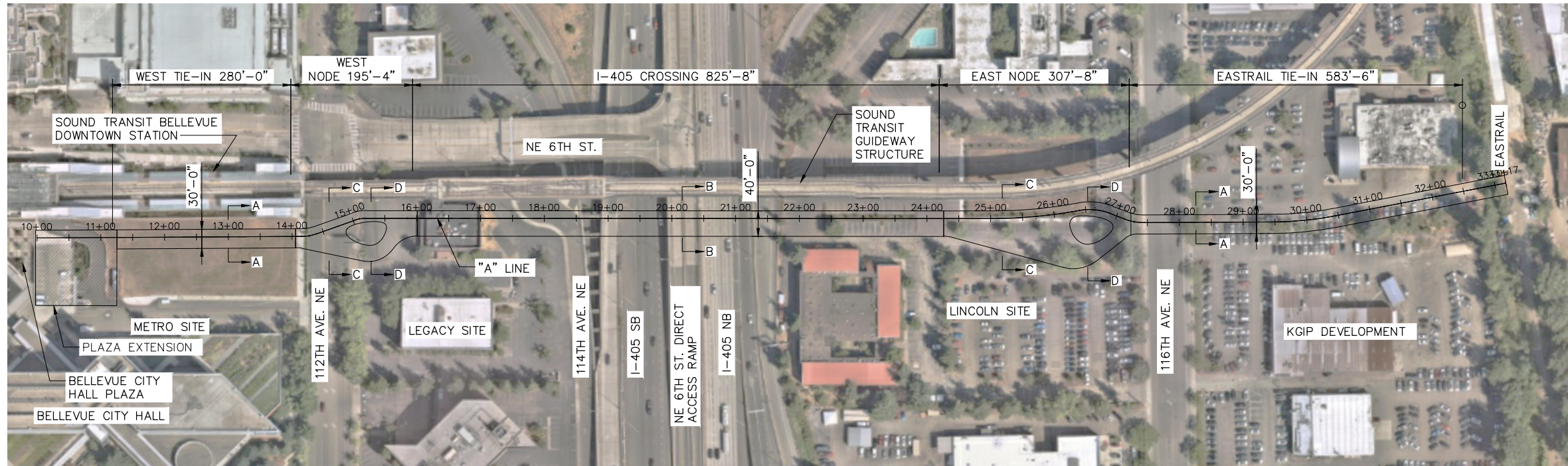

PLAN

NOTES:

1. CAST-IN-PLACE POST-TENSIONED BOX GIRDER ALTERNATIVE FOR I-405 CROSSING STRUCTURE WITH NO PIER IN NE 6TH ST. DIRECT ACCESS RAMP SHOWN.
2. FOR SECTION A-A OF WEST TIE-IN AND EASTRAIL TIE-IN STRUCTURES, SEE SHEET B-102A.
3. FOR SECTION B-B OF I-405 CROSSING STRUCTURE, SEE B-102B.
4. FOR SECTION C-C OF WEST AND EAST NODE STRUCTURES, SEE B-102C.
5. FOR SECTION D-D OF WEST AND EAST NODE STRUCTURES AT OCULUS, SEE SHEET B-102C.

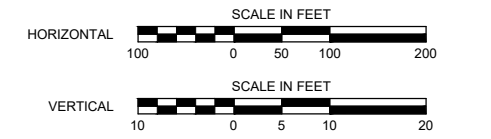
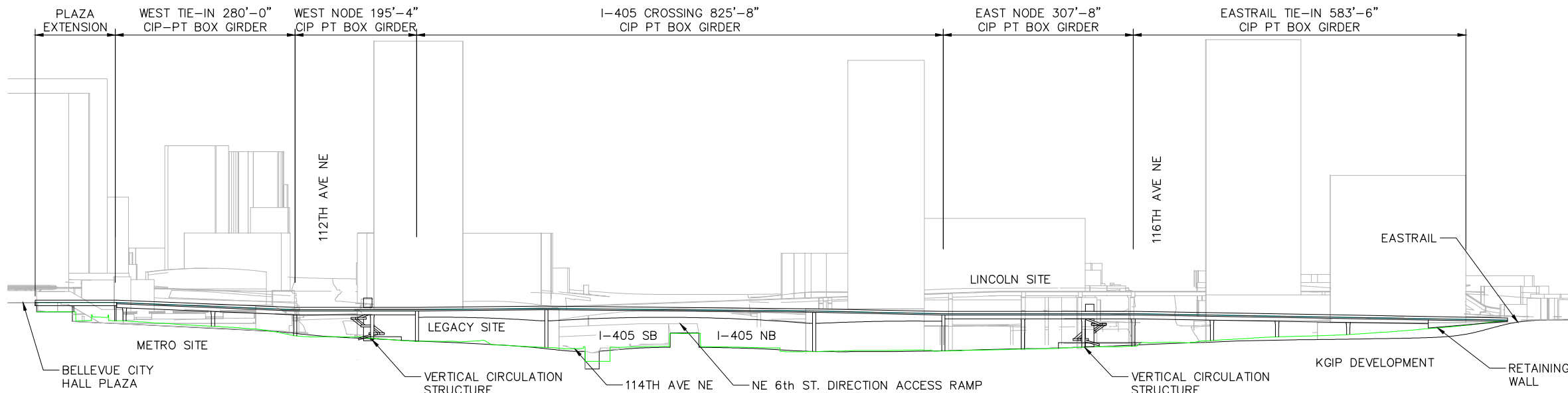

ELEVATION

NO.	DATE	BY	APPR.	REVISIONS

F. SUNAGO 7/31/24
 DESIGNED BY DATE
 D. DE LA CRUZ / J. JAYNES 7/31/24
 DRAWN BY DATE
 M. BARBER / S. BENNION 7/31/24
 CHECKED BY DATE

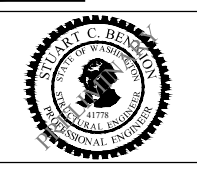
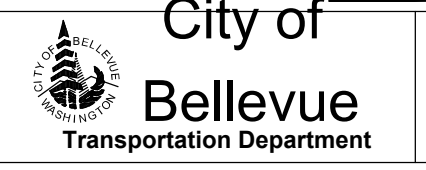

BELLEVUE GRAND CONNECTION
 PLAZA EXTENSION & CIP PT BOX GIRDER WEST TIE-IN
 WITH CIP PT BOX GIRDER I-405 CROSSING

OVERALL PLAN AND ELEVATION

B-101A SHT ##### OF ##

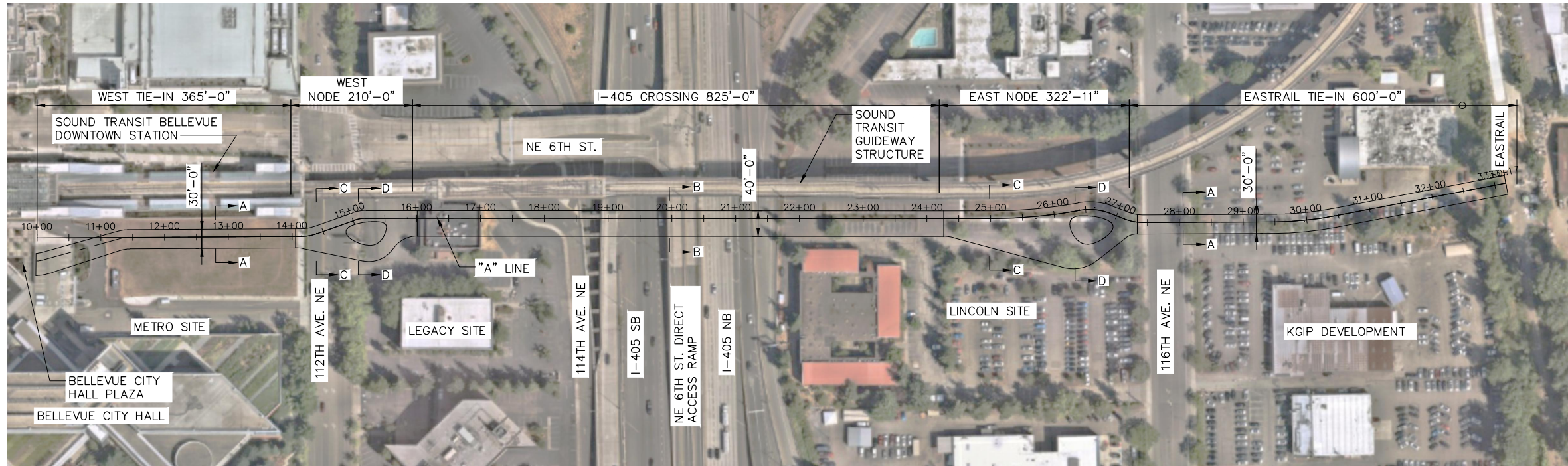

PLAN

NOTES:

1. CAST-IN-PLACE POST-TENSIONED BOX GIRDER ALTERNATIVE FOR I-405 CROSSING STRUCTURE WITH NO PIER IN NE 6TH ST. DIRECT ACCESS RAMP SHOWN.
2. FOR SECTION A-A OF EASTRAIL TIE-IN STRUCTURES, SEE SHEET B-102A.
3. FOR SECTION B-B OF I-405 CROSSING STRUCTURE, SEE B-102B.
4. FOR SECTION C-C OF WEST AND EAST NODE STRUCTURES, SEE B-102C.
5. FOR SECTION D-D OF WEST AND EAST NODE STRUCTURES AT OCULUS, SEE SHEET B-102C.

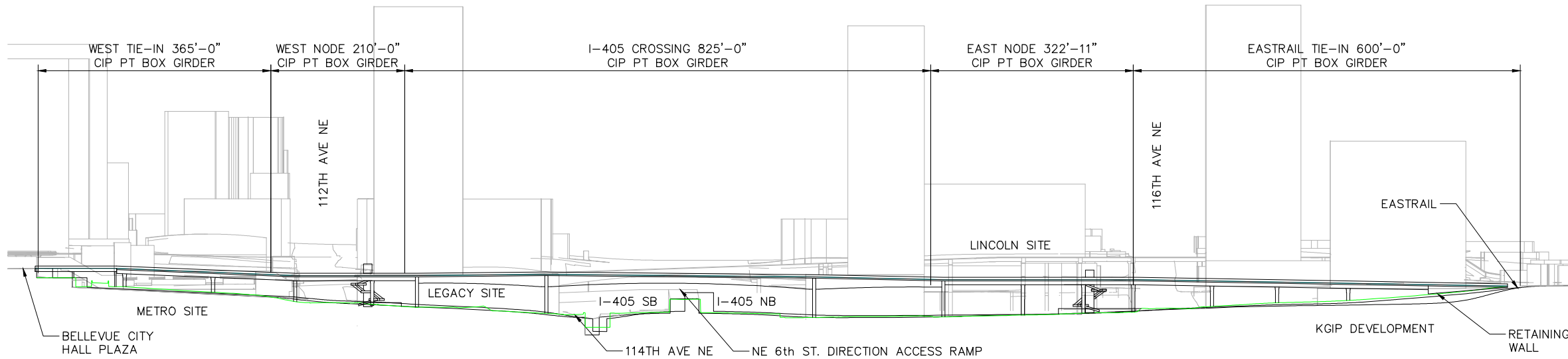

ELEVATION

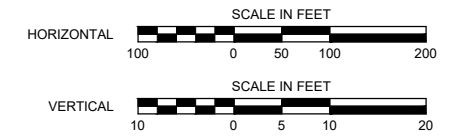

NO.	DATE	BY	APPR.	REVISIONS

F. SUNAGO 7/31/24
 DESIGNED BY DATE
 D. DE LA CRUZ / J. JAYNES 7/31/24
 DRAWN BY DATE
 M. BARBER / S. BENNION 7/31/24
 CHECKED BY DATE

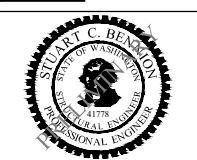

BELLEVUE GRAND CONNECTION
 CIP PT BOX GIRDER WEST TIE-IN
 WITH CIP PT BOX GIRDER I-405 CROSSING

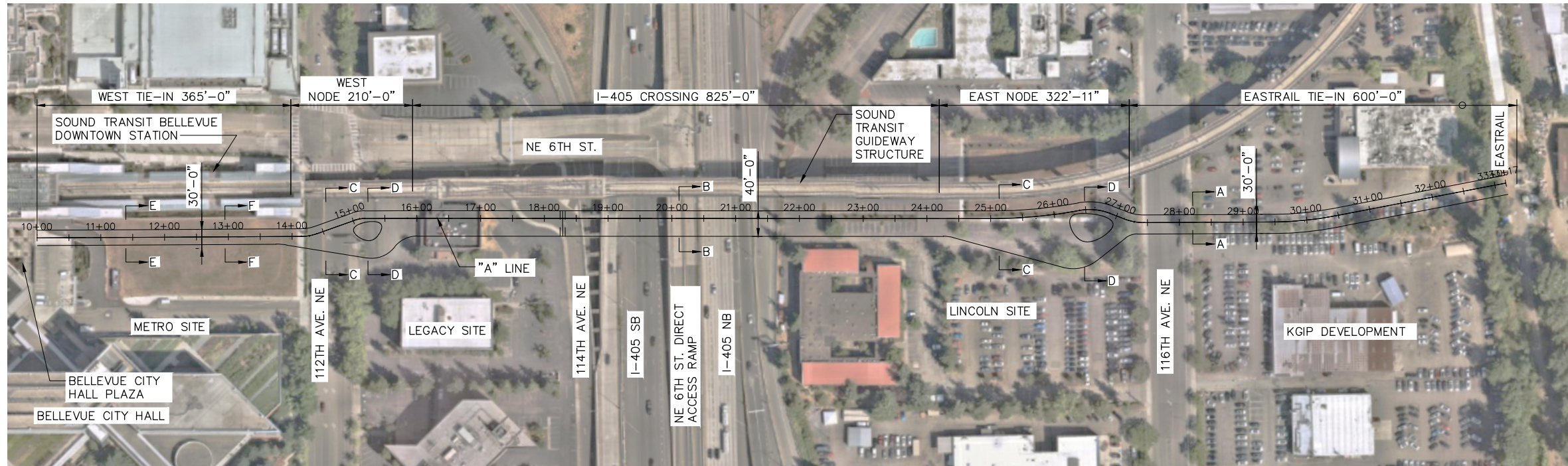

PLAN

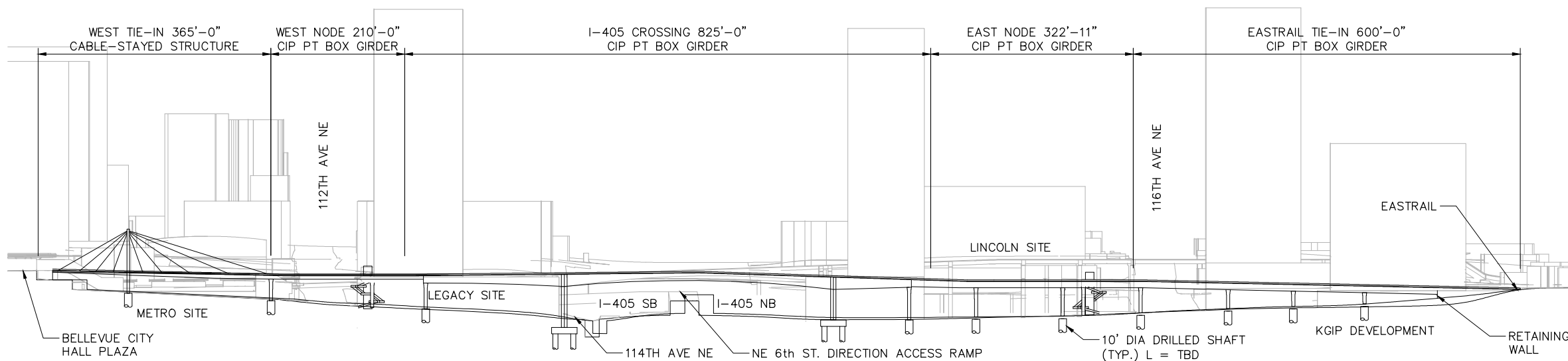

ELEVATION

- NOTES:**
1. CAST-IN-PLACE POST-TENSIONED BOX GIRDER ALTERNATIVE FOR I-405 CROSSING STRUCTURE WITH NO PIER IN NE 6TH ST. DIRECT ACCESS RAMP SHOWN.
 2. FOR SECTION A-A OF EASTRAIL TIE-IN STRUCTURES, SEE SHEET B-102A.
 3. FOR SECTION B-B OF I-405 CROSSING STRUCTURE, SEE B-102B.
 4. FOR SECTION C-C OF WEST AND EAST NODE STRUCTURES, SEE B-102C.
 5. FOR SECTION D-D OF WEST AND EAST NODE STRUCTURES AT OCULUS, SEE SHEET B-102C.
 6. FOR SECTION E-E AND F-F OF WEST TIE-IN STRUCTURE, SEE SHEET B-102D.

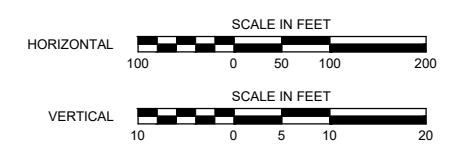

NO.	DATE	BY	APPR.	REVISIONS

F. SUNAGO 7/31/24
 DESIGNED BY DATE
 D. DE LA CRUZ / J. JAYNES 7/31/24
 DRAWN BY DATE
 M. BARBER / S. BENNION 7/31/24
 CHECKED BY DATE

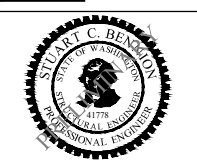

BELLEVUE GRAND CONNECTION
 CABLE STAYED WEST TIE-IN
 WITH CIP PT BOX GIRDER I-405 CROSSING

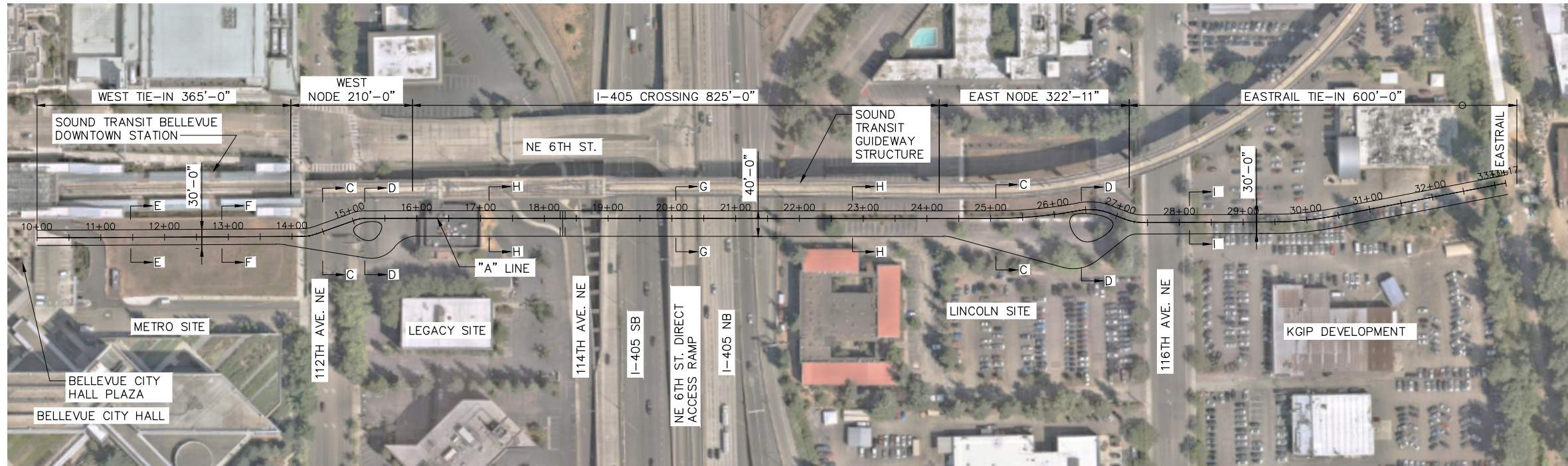

PLAN

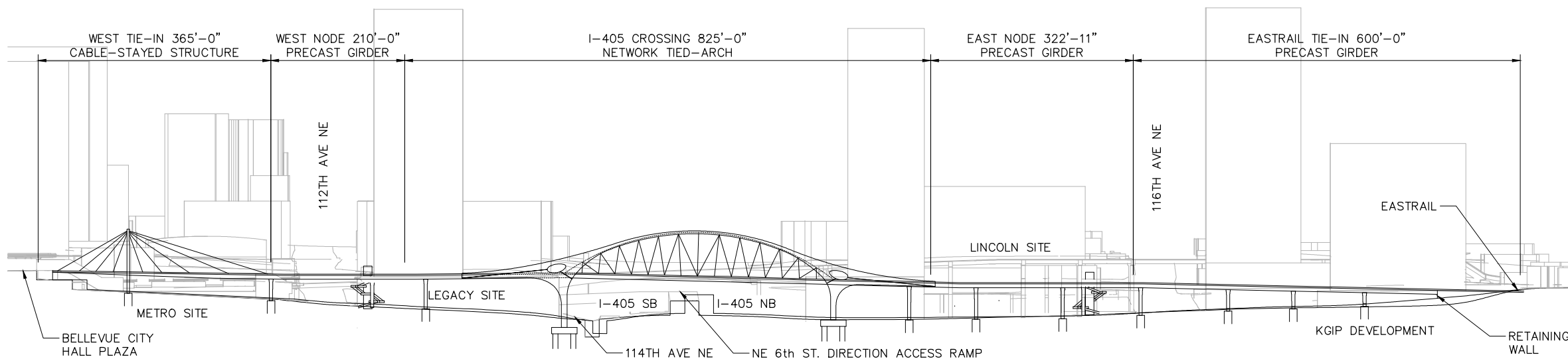

ELEVATION

NOTES:

1. NETWORK TIED ARCH ALTERNATIVE FOR I-405 CROSSING STRUCTURE SHOWN.
2. FOR SECTION C-C OF WEST AND EAST NODE STRUCTURES, SEE B-102C.
3. FOR SECTION D-D OF WEST AND EAST NODE STRUCTURES AT OCULUS, SEE SHEET B-102C.
4. FOR SECTION E-E AND F-F OF WEST TIE-IN STRUCTURE, SEE B-102D.
5. FOR SECTION G-G OF I-405 CROSSING STRUCTURE MAIN SPAN, SEE SHEET B-102E.
6. FOR SECTION H-H OF EASTRAIL TIE-IN STRUCTURE, SEE SHEET B-102F.
7. FOR SECTION I-I OF EASTRAIL TIE-IN STRUCTURE, SEE B-102G.

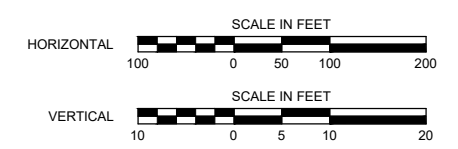

NO.	DATE	BY	APPR.	REVISIONS

F. SUNAGO 7/31/24
 DESIGNED BY DATE
 D. DE LA CRUZ / J. JAYNES 7/31/24
 DRAWN BY DATE
 M. BARBER / S. BENNION 7/31/24
 CHECKED BY DATE

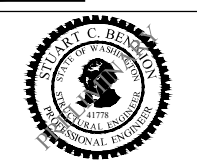

BELLEVUE GRAND CONNECTION
 CABLE STAYED WEST TIE-IN
 WITH NETWORK TIED ARCH I-405 CROSSING

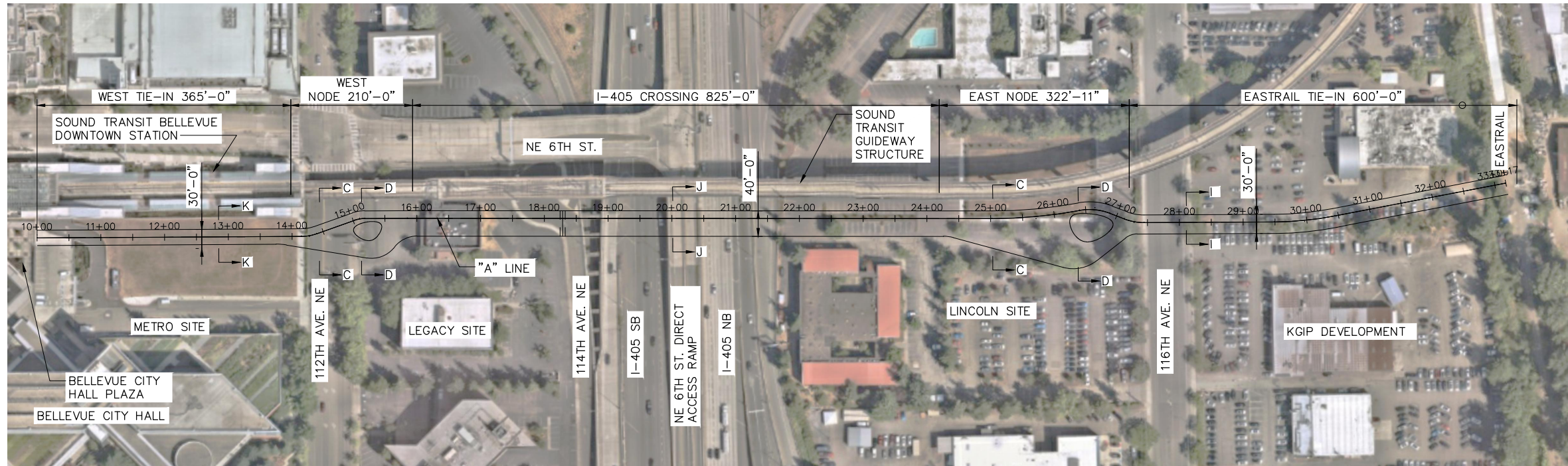

PLAN



NOTES:

1. STEEL TRUSS ALTERNATIVE FOR I-405 CROSSING STRUCTURE SHOWN.
2. FOR SECTION C-C OF WEST AND EAST NODE STRUCTURES, SEE B-102C.
3. FOR SECTION D-D OF WEST AND EAST NODE STRUCTURES AT OCULUS, SEE SHEET B-102C.
4. FOR SECTION K-K OF WEST TIE-IN STRUCTURE, SEE B-102I.
5. FOR SECTION J-J OF I-405 CROSSING STRUCTURE MAIN SPAN, SEE SHEET B-102H.
6. FOR SECTION I-I OF EASTRAIL TIE-IN STRUCTURE, SEE SHEET B-102G.

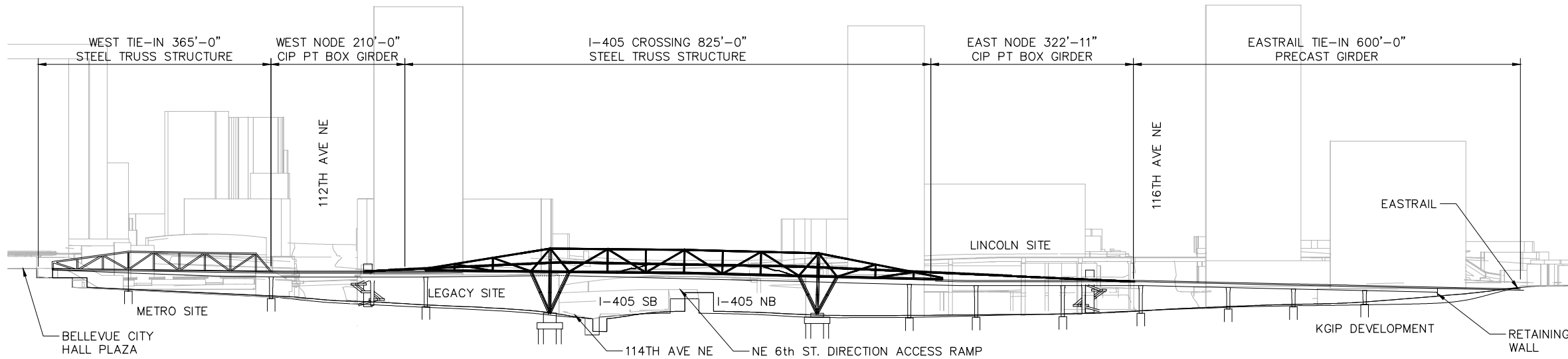

ELEVATION

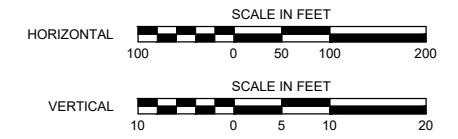

NO.	DATE	BY	APPR.	REVISIONS

F. SUNAGO 7/31/24
 DESIGNED BY DATE
 D. DE LA CRUZ / J. JAYNES 7/31/24
 DRAWN BY DATE
 M. BARBER / S. BENNION 7/31/24
 CHECKED BY DATE

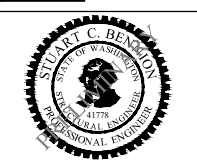

BELLEVUE GRAND CONNECTION
 STEEL TRUSS WEST TIE-IN
 WITH STEEL TRUSS I-405 CROSSING

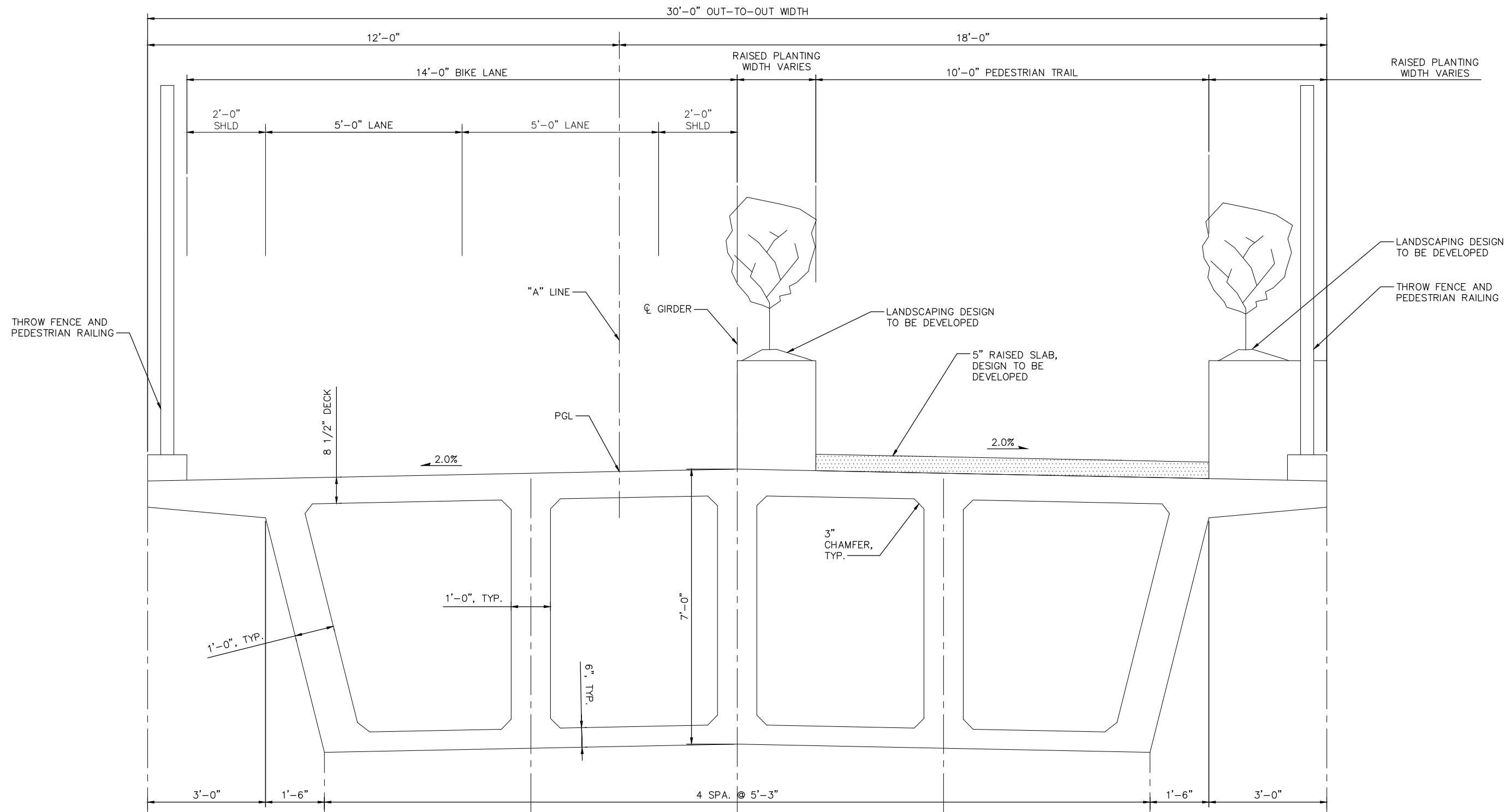

SECTION A-A
SCALE: 3/4"=1'-0"

- NOTES:**
1. TYPICAL SECTION OF 30'-0" WIDE WEST TIE-IN AND STRUCTURES, CIP PT BOX GIRDER ALTERNATIVE SHOWN.
 2. WIDTH OF RAISED PLANTING AND LANDSCAPING WILL VARY THROUGHOUT THE STRUCTURE.

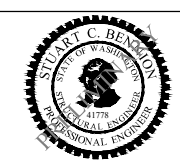
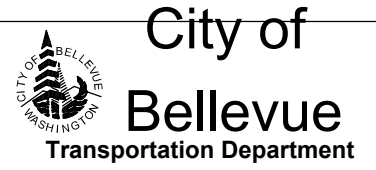

**BELLEVUE GRAND CONNECTION
WEST TIE-IN EASTRAIL TIE-IN STRUCTURE
CIP PT BOX GIRDER ALTERNATIVE**

TYPICAL SECTION

B-102A SHT #### OF ##

NO.	DATE	BY	APPR.	REVISIONS

F. SUNAGO 7/31/24
DESIGNED BY DATE
D. DE LA CRUZ / J. JAYNES 7/31/24
DRAWN BY DATE
7/31/24 7/31/24
CHECKED BY DATE

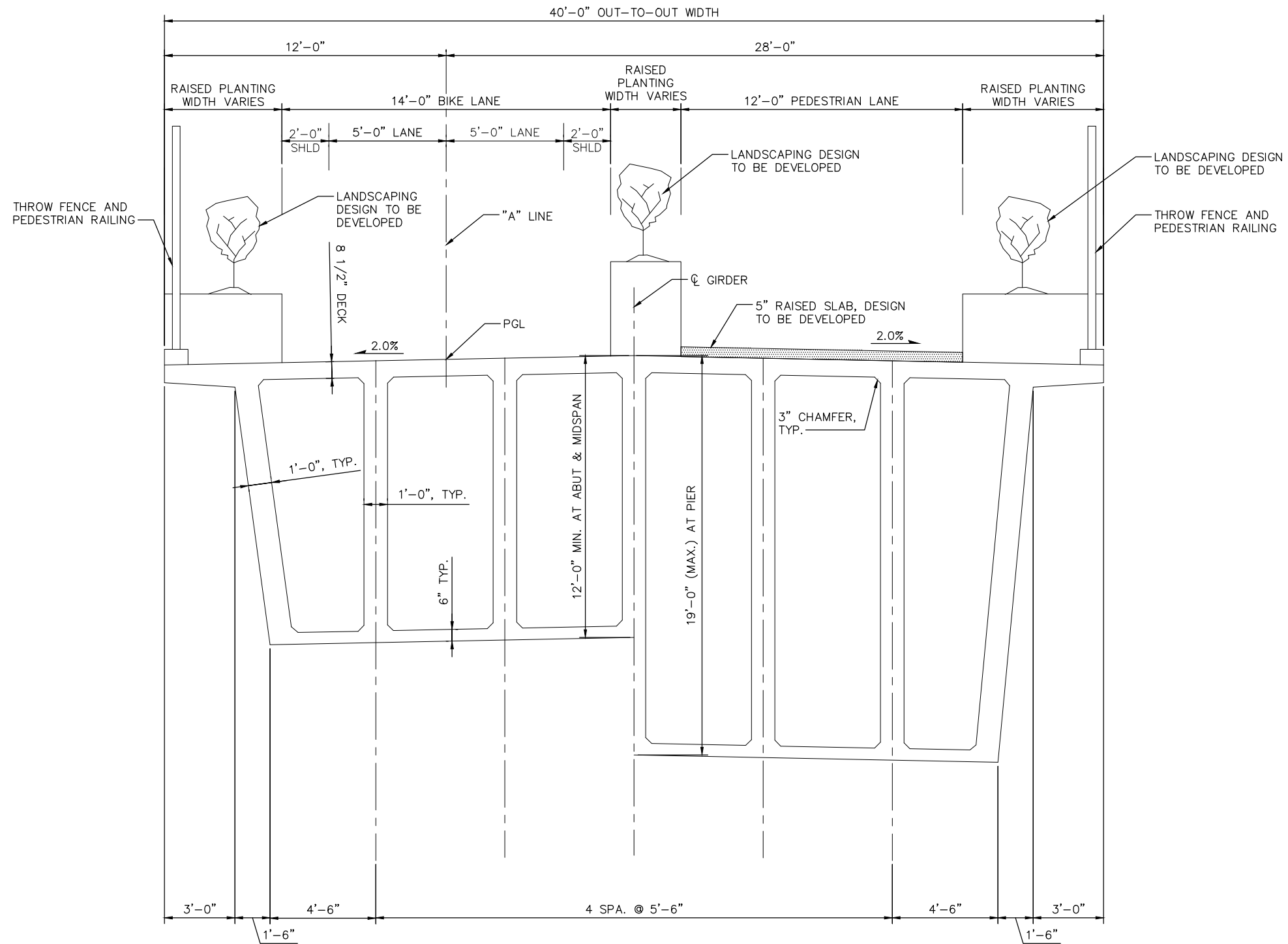

SECTION B-B
SCALE: 3/8"=1'-0"

NOTES:

1. TYPICAL SECTION OF 40'-0 WIDE I-4052 CROSSING STRUCTURE, CIP PT BOX GIRDER ALTERNATIVE SHOWN.
2. WIDTH OF RAISED PLANTING AND LANDSCAPING WILL VARY THROUGHOUT THE STRUCTURE.

NO.	DATE	BY	APPR.	REVISIONS

F. SUNAGO 7/31/24
DESIGNED BY DATE
D. DE LA CRUZ / J. JAYNES 7/31/24
DRAWN BY DATE
M. BARBER / S. BENNION 7/31/24
CHECKED BY DATE

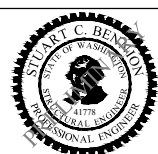

BELLEVUE GRAND CONNECTION
I-405 CROSSING STRUCTURE
CIP PT BOX GIRDER ALTERNATIVE



TYPICAL SECTION

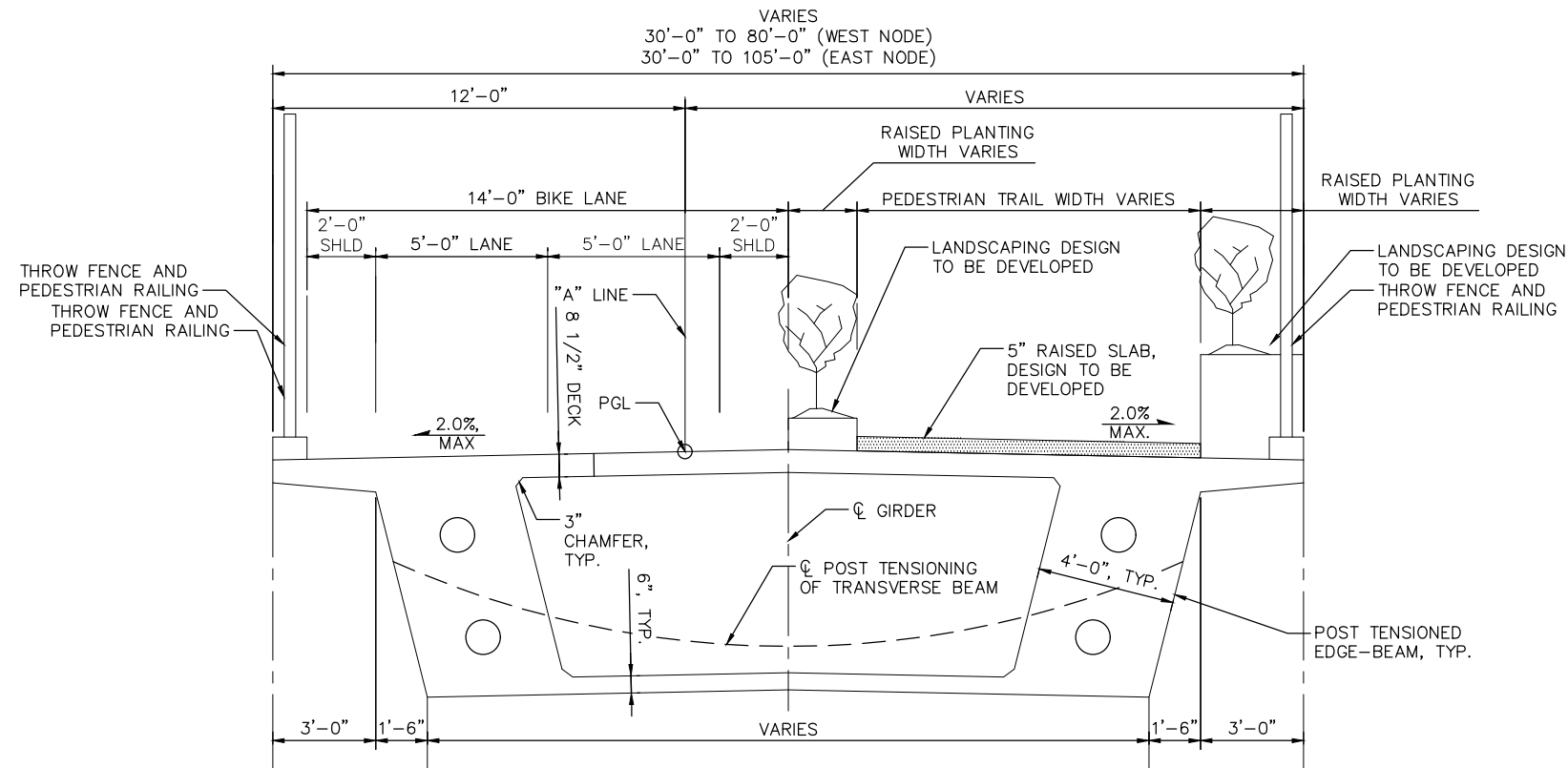

SECTION C-C
SCALE: 3/8"=1'-0"

NOTES:

1. TYPICAL SECTION OF WEST AND EAST NODE STRUCTURES, CIP SHOWN.
2. WIDTH OF RAISED PLANTING AND LANDSCAPING WILL VARY THROUGHOUT THE STRUCTURE.

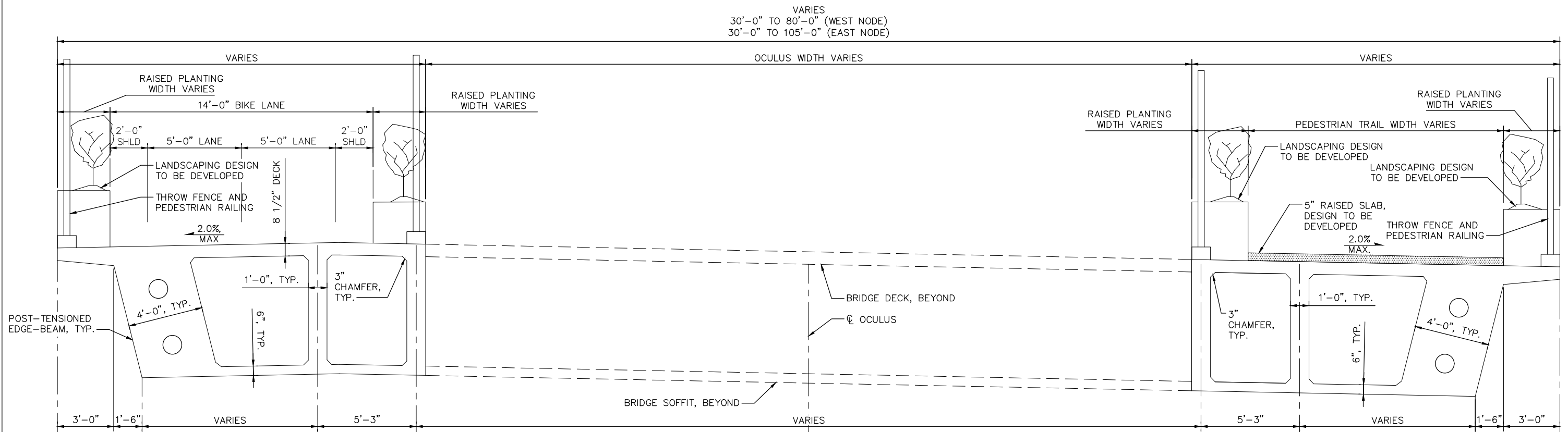

SECTION D-D
SCALE: 3/8"=1'-0"

NO.	DATE	BY	APPR.	REVISIONS

F. SUNAGO 7/31/24
DESIGNED BY DATE
D. DE LA CRUZ / J. JAYNES 7/31/24
DRAWN BY DATE
M. BARBER / S. BENNION 7/31/24
CHECKED BY DATE

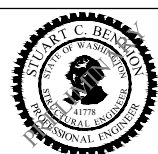

BELLEVUE GRAND CONNECTION
WEST AND EAST NODE STRUCTURES
CIP PT STRUCTURE



TYPICAL SECTIONS

B-102C SHT ____ OF ##

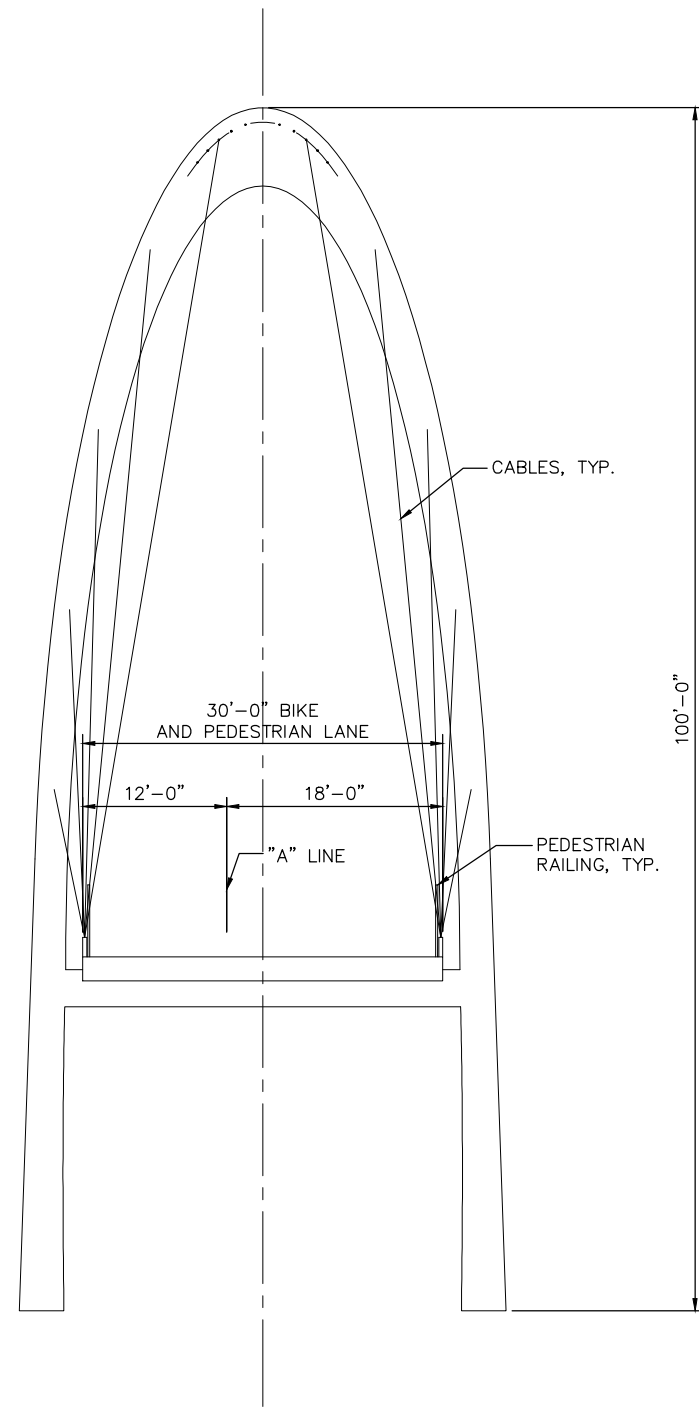

SECTION E-E: SECTION AT PYLON
SCALE: 1/8"=1'-0"

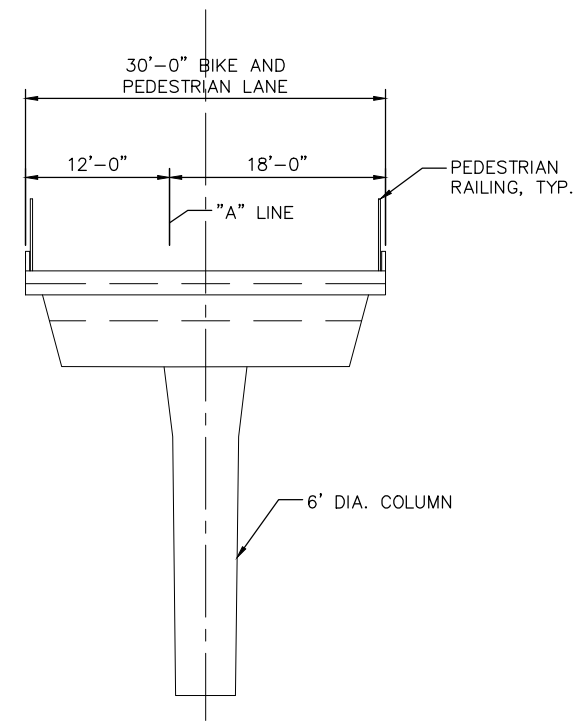

SECTION F-F: SECTION AT PIER
SCALE: 1/8"=1'-0"

NO.	DATE	BY	APPR.	REVISIONS

F. SUNAGO 7/31/24
DESIGNED BY DATE
D. DE LA CRUZ / J. JAYNES 7/31/24
DRAWN BY DATE
M. BARBER / S. BENNION 7/31/24
CHECKED BY DATE

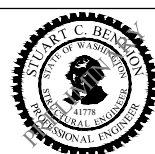
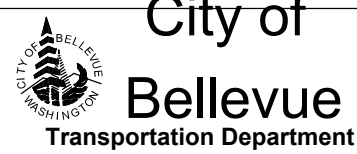

BELLEVUE GRAND CONNECTION
WEST TIE-IN STRUCTURE
CABLE-STAYED ALTERNATIVE



SECTION

B-102D SHT ____ OF ##

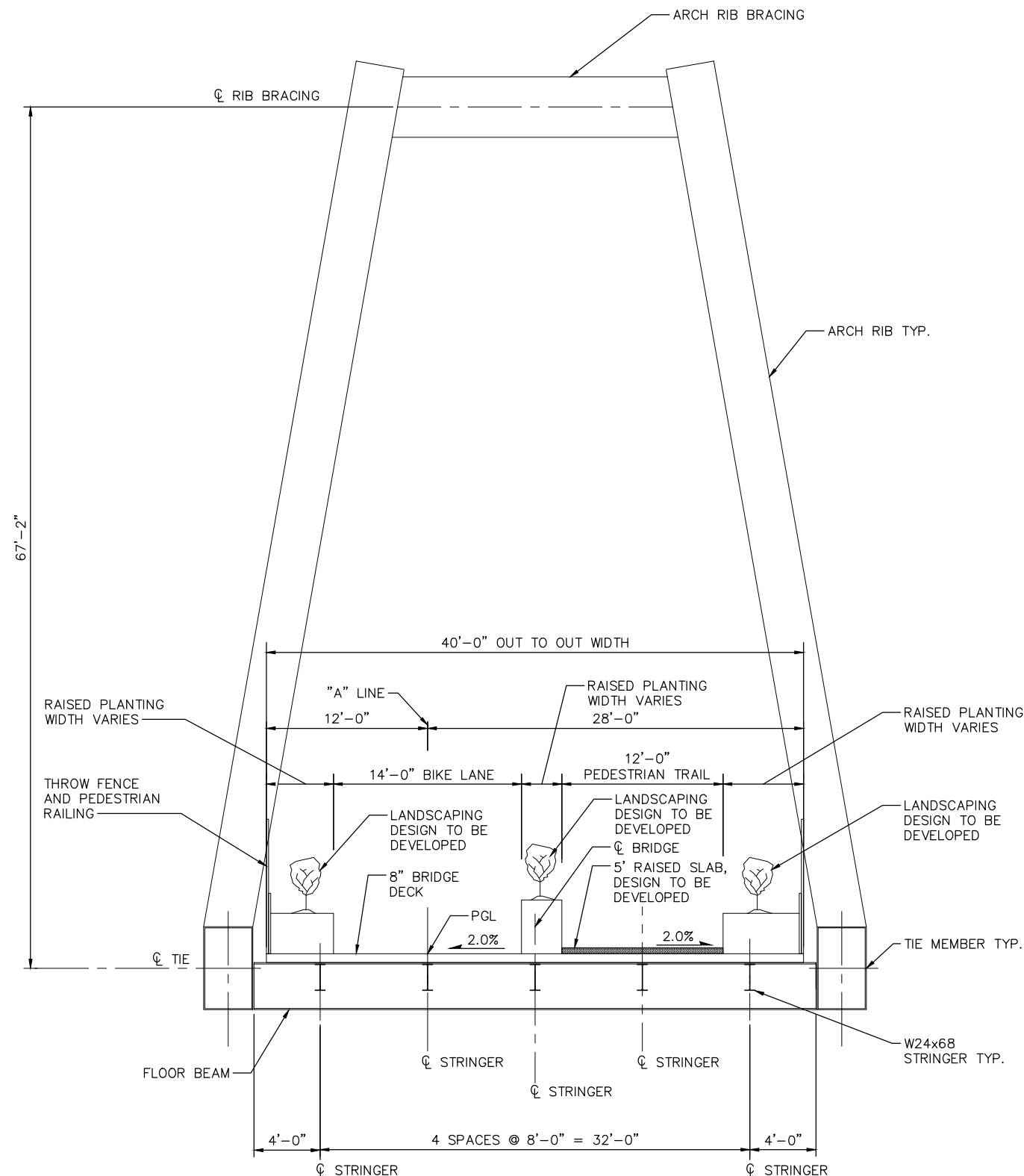

SECTION G-G
SCALE: 3/16"=1'-0"

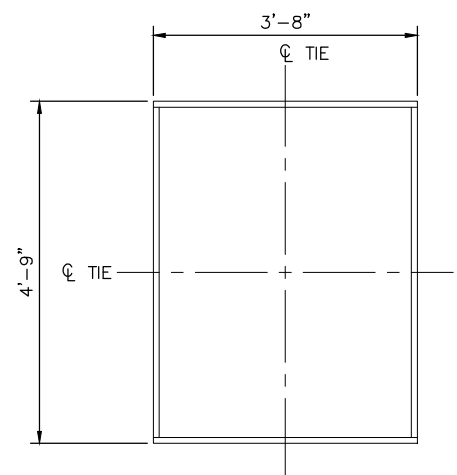

TYPICAL ARCH RIB SECTION
SCALE: 3/4"=1'-0"

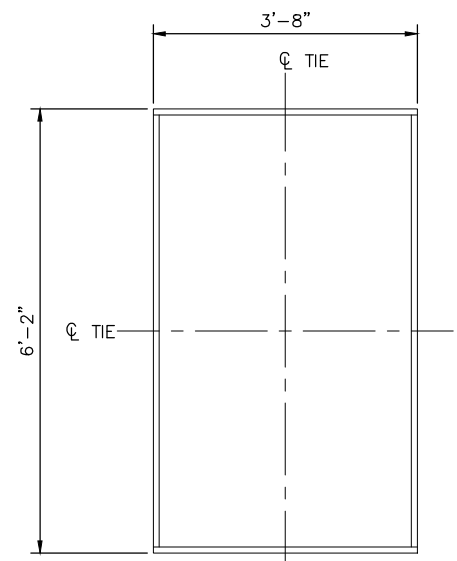

TYPICAL HORIZONTAL TIE SECTION
SCALE: 3/4"=1'-0"

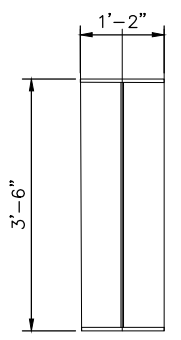

TYPICAL FLOOR BEAM SECTION
SCALE: 3/4"=1'-0"

NOTES:

1. END VIEW OF 40'-0" WIDE I-405 CROSSING STRUCTURE, MAIN SPAN, NETWORK TIED ARCH ALTERNATIVE SHOWN.
2. WIDTH OF RAISED PLANTING AND LANDSCAPING WILL VARY THROUGHOUT THE STRUCTURE.

NO.	DATE	BY	APPR.	REVISIONS

F. SUNAGO 7/31/24
DESIGNED BY DATE
D. DE LA CRUZ / J. JAYNES 7/31/24
DRAWN BY DATE
M. BARBER / S. BENNION 7/31/24
CHECKED BY DATE

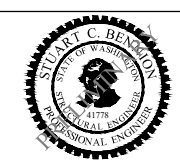

**BELLEVUE GRAND CONNECTION
I-405 CROSSING STRUCTURE
NETWORK TIED ARCH ALTERNATIVE**



SECTION - MAIN SPAN

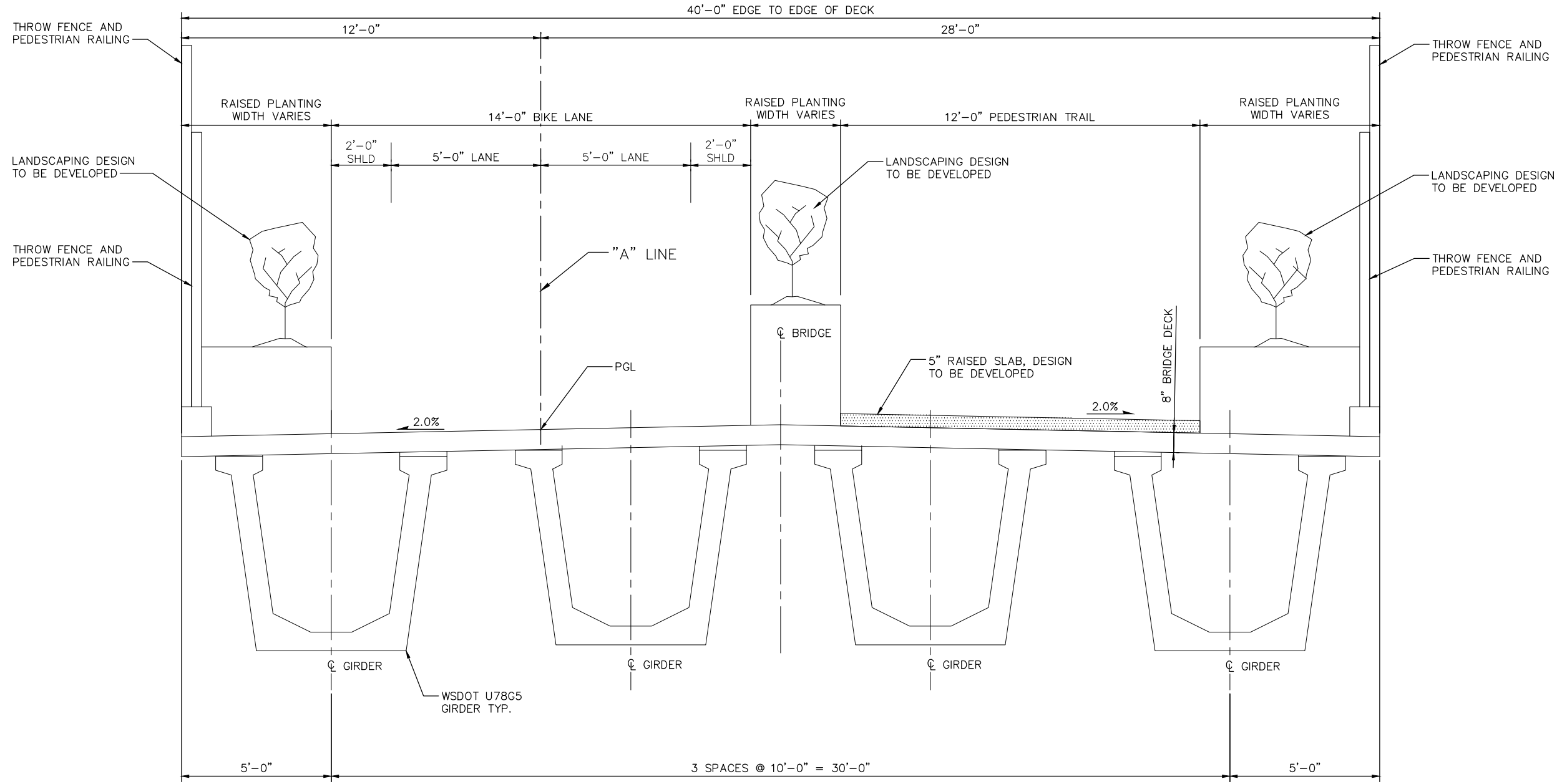

SECTION H-H
SCALE: 1/2"=1'-0"



NO.	DATE	BY	APPR.	REVISIONS

F. SUNAGO 7/31/24
DESIGNED BY DATE
D. DE LA CRUZ 7/31/24
DRAWN BY DATE
M. BARBER / S. BENNION 7/31/24
CHECKED BY DATE

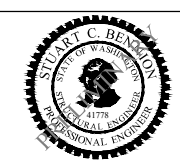

BELLEVUE GRAND CONNECTION
I-405 CROSSING STRUCTURE
NETWORK TIED ARCH ALTERNATIVE

SECTION - APPROACH SPAN

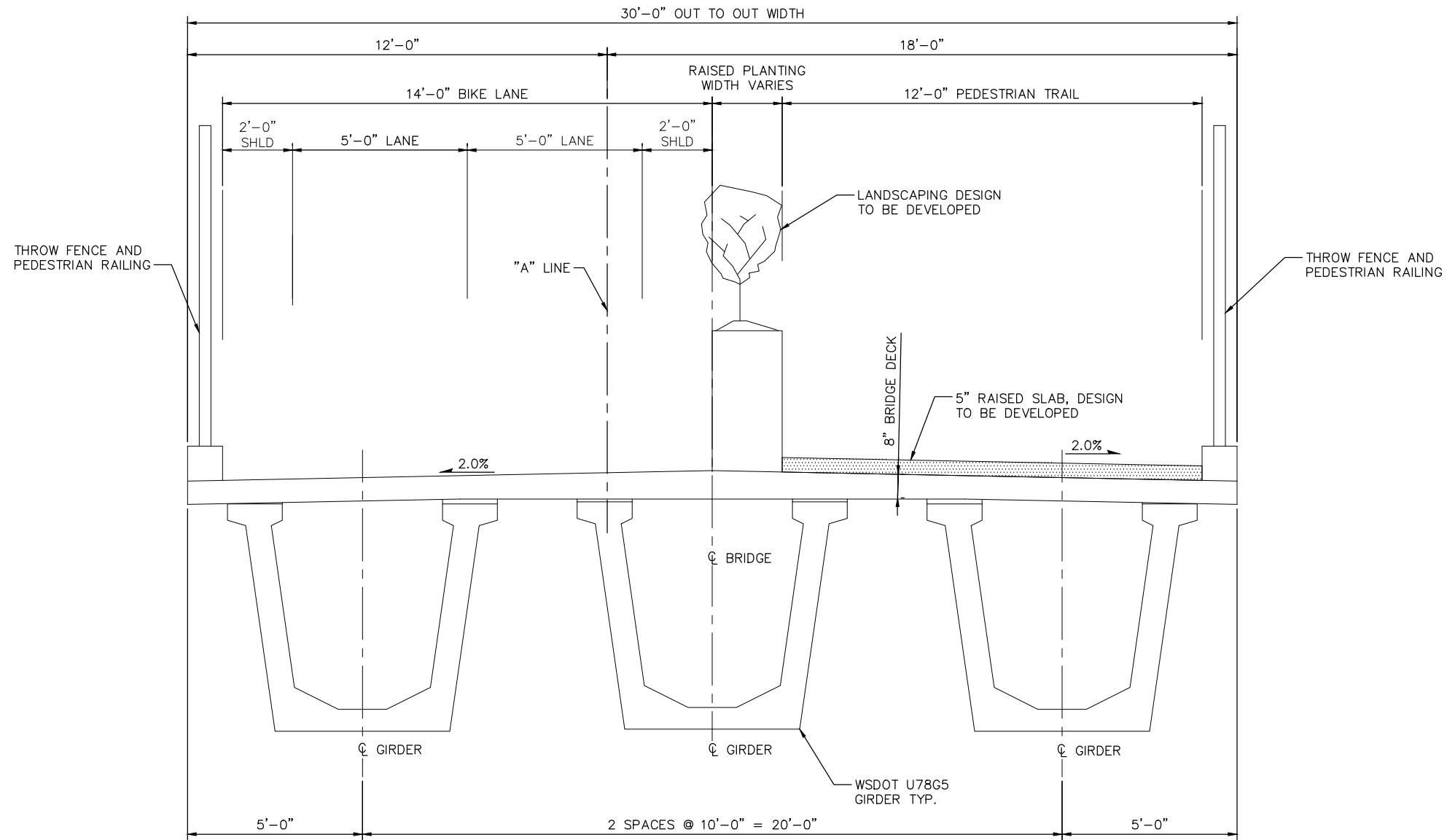

SECTION I-I
SCALE: 1/2"=1'-0"

NOTES:

1. TYPICAL SECTION OF 30'-0" WIDE WEST TIE-IN AND STRUCTURES, CIP PT BOX GIRDER ALTERNATIVE SHOWN.
2. WIDTH OF RAISED PLANTING AND LANDSCAPING WILL VARY THROUGHOUT THE STRUCTURE.

NO.	DATE	BY	APPR.	REVISIONS

F. SUNAGO 7/31/24
DESIGNED BY DATE
D. DE LA CRUZ 7/31/24
DRAWN BY DATE
M. BARBER / S. BENNION 7/31/24
CHECKED BY DATE

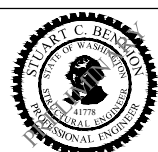

**BELLEVUE GRAND CONNECTION
EASTRAIL TIE-IN STRUCTURE
PRECAST TUB GIRDER STRUCTURE**



SECTION

B-102G SHT ____ OF ##

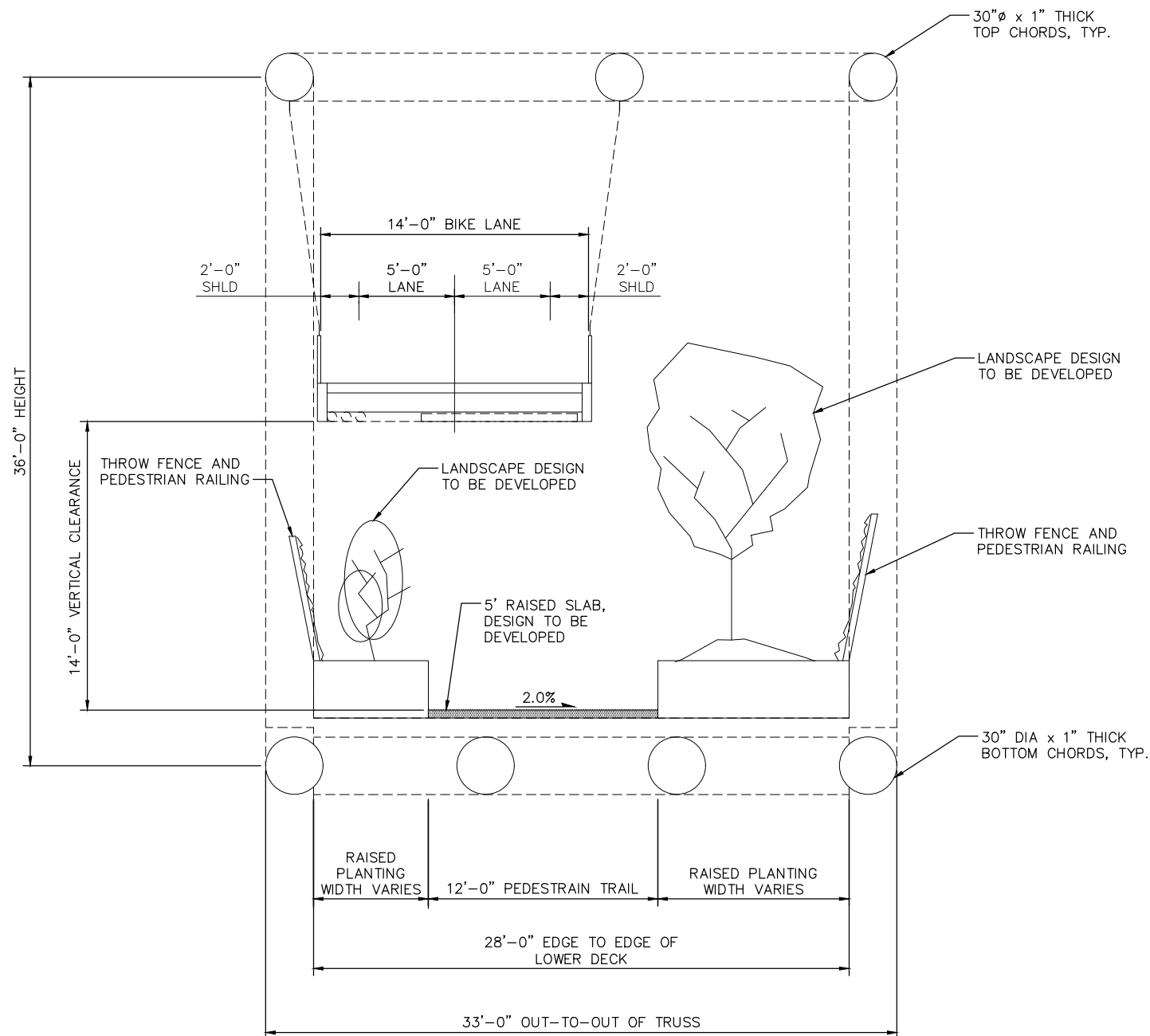

SECTION J-J
SCALE: 1/4"=1'-0"

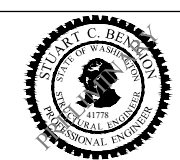

**BELLEVUE GRAND CONNECTION
I-405 CROSSING STRUCTURE
STEEL TRUSS ALTERNATIVE**

SECTION

B-102H SHT ____ OF ##

NO.	DATE	BY	APPR.	REVISIONS

F. SUNAGO 7/31/24
DESIGNED BY DATE
D. DE LA CRUZ / J. JAYNES 7/31/24
DRAWN BY DATE
M. BARBER / S. BENNION 7/31/24
CHECKED BY DATE

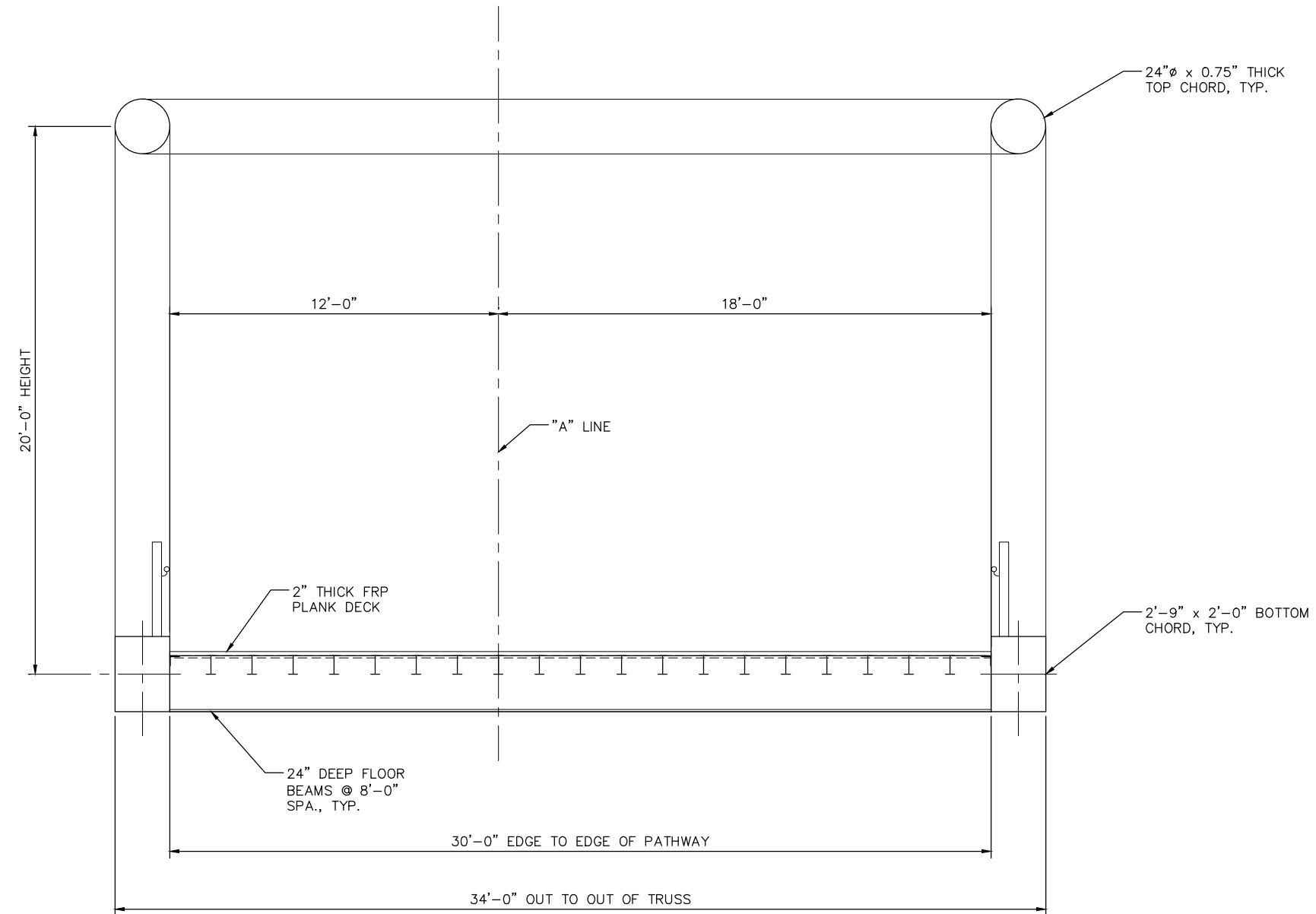

SECTION K-K
SCALE: 3/8"=1'-0"



NO.	DATE	BY	APPR.	REVISIONS

Z. VAN BRUNDT 7/31/24
DESIGNED BY DATE
D. DE LA CRUZ / J. JAYNES 7/31/24
DRAWN BY DATE
M. BARBER / S. BENNION 7/31/24
CHECKED BY DATE

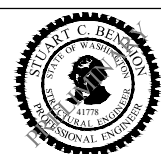
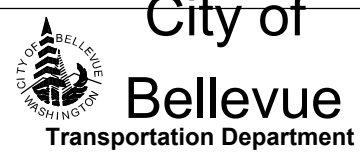

BELLEVUE GRAND CONNECTION
WEST TIE-IN STRUCTURE
TRUSS ALTERNATIVE

SECTION

B-102I SHT ____ OF ##