

PLAN – BIORETENTION CELL
OVERFLOW
WITH CONVEYANCE FURROW

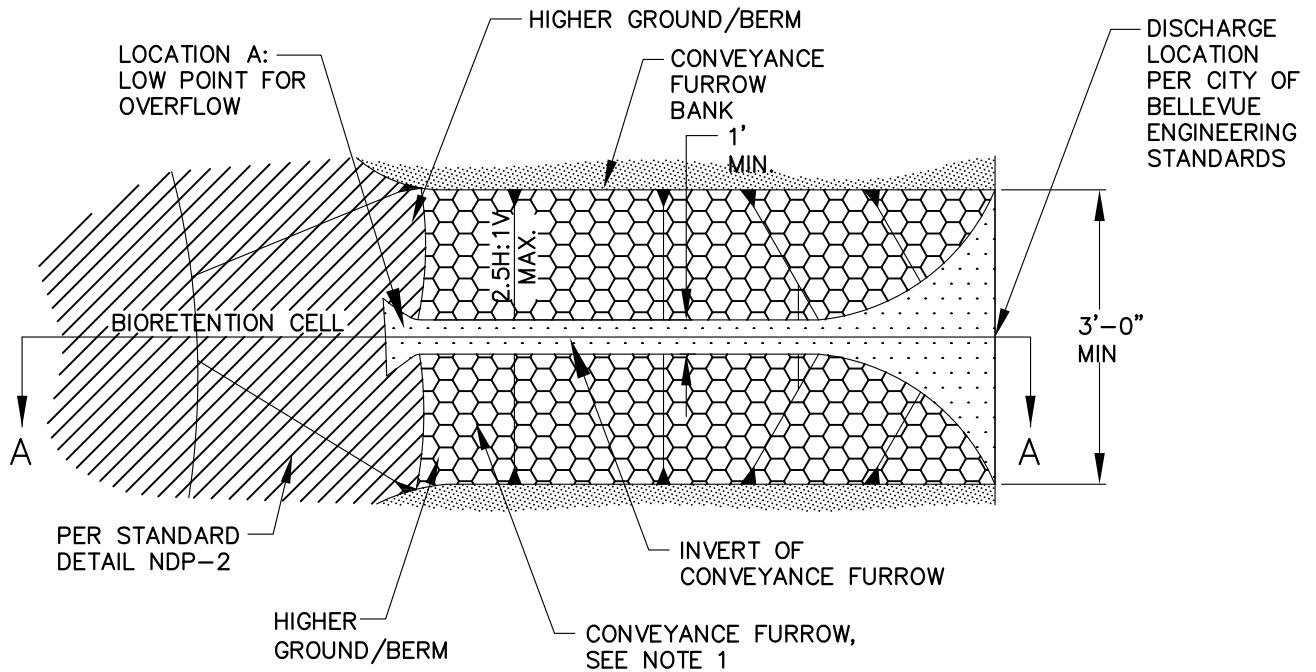

SECTION A – BIORETENTION CELL
OVERFLOW
WITH CONVEYANCE FURROW

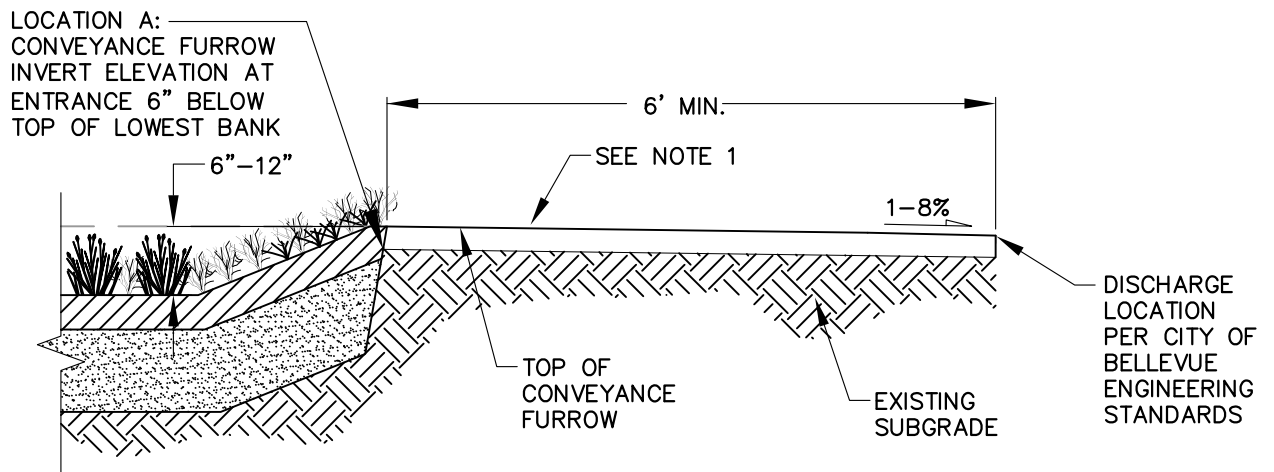

NOTE:

1. LINE CONVEYANCE FURROW WITH STREAMBED COBBLE PER STANDARD SPECIFICATIONS 9-03.11(2) (MIN 6" DEPTH) FOR DESIGN FLOW UP TO 4 F.P.S., OR MIN. 12" BIORETENTION SOIL MIX FOR DESIGN FLOW LESS THAN 4 F.P.S. AND PLANT WITH BIORETENTION GROUND COVERS OR TURF, OR PER ENGINEER'S DESIGN.

	<h2>City of Bellevue</h2>	STORM AND SURFACE WATER UTILITY
	TITLE BIORETENTION OVERFLOW WITH CONVEYANCE FURROW	