



**City of Bellevue
Development Services Department
Land Use Division Staff Report**

Proposal Name: East Link Central Bellevue Segment

Proposal Address: Approximately SE 4th St on 112th Ave SE to 120th Ave NE

Proposal Description: Design and Mitigation Permit approval to construct the East Link regional light rail transit facilities (RLRT facilities) and regional light rail transit system (RLRT system) in the Central Bellevue area of the City of Bellevue.

File Number: 15-102719 LD

Applicant: Sound Transit

Decisions Included: Design and Mitigation Permit (Process II)

Planner: Matthews Jackson
Planning Manager

State Environmental Policy Act Final Environmental Impact Statement (FEIS) was issued for the East Link RLRT project on July 15, 2011

Director's Recommendation: **Approval with Conditions**
Michael A. Brennan, Director
Development Services Department

By: Carol V. Helland
Carol V. Helland, Land Use Director

Notice of Application: February 26, 2015
Notice of Decision: May 5, 2016
Appeal Deadline: May 19, 2016

For information on how to appeal a proposal, visit the Development Services Center at City Hall or call (425) 452-6800. Comments on State Environmental Policy Act (SEPA) Determinations can be made with or without appealing the proposal within the noted comment period for a SEPA Determination. Appeal of the Decision must be received in the City Clerk's Office by 5 PM on the date noted for appeal of the decision.

CONTENTS

I.	Request/Proposal Description.....	Pg. 2
II.	Zoning and Context.....	Pg. 15
III.	Consistency with Zoning Requirements.....	Pg. 19
IV.	Design Standards and Guidelines.....	Pg. 19
V.	Public Notice and Comment.....	Pg. 47
VI.	Technical Review.....	Pg. 48
VII.	State Environmental Policy Act (SEPA).....	Pg. 52
VIII.	Changes as a Result of Project Review.....	Pg. 60
IX.	Decision Criteria.....	Pg. 60
X.	Decision.....	Pg. 63
XI.	Conditions of Approval.....	Pg. 63

ATTACHED:

- A. CAC Context Setting Advisory Document
- B. Central Bellevue Segment CAC Pre-Development Advisory Document
- C. Central Bellevue Segment CAC Design and Mitigation Permit Advisory Document
- D. Wetland, Stream, and Jurisdictional Ditch Delineation Report
- E. East Link Light Rail Extension Critical Areas Report and Mitigation Plan
- F. Plans and Drawings

I. REQUEST/PROPOSAL DESCRIPTION

A. Background

The Central Puget Sound Regional Transit Authority (“Sound Transit” or the “Applicant”) is proposing to construct the first phase of Sound Transit 2, a new Regional Light Rail Transit (RLRT) Facility between Seattle and the east side of Lake Washington, known as the East Link Project (East Link). The East Link project was approved by voters under the Sound Transit 2 plan in 2008. Since initial approval in 2008, Sound Transit has worked closely with the City of Bellevue (City) to design a RLRT facility that meets regional and City needs while following the voter-approved alignment. A complete project history, including description of City engagement benchmarks, can be found in Section 1.1 of the project narrative (the “Narrative”).

Allowed Use

The proposed East Link RLRT facility is considered a permitted use under LUC 20.10.440 when the City Council has included the alignment location and profile of the RLRT system and facility in a resolution, ordinance, or development agreement (see LUC 20.10.440 “Transportation and Utilities” Footnote 25). The Bellevue City Council passed Resolution No. 8576 including the alignment location and profile on April 22, 2013, and the East Link RLRT facility as proposed in this application is consistent with the Council resolution. The alignment proposed by Sound Transit with this application is allowed subject to approval of a Design and Mitigation Permit.

B. Review Process

Design and Mitigation Permits are governed by Land Use Code (LUC) 20.25M. The Design and Mitigation Permit is a Process II administrative decision made by the Director of the Development Services Department or designee. An appeal of any Process II decision is heard and decided upon by the City of Bellevue Hearing Examiner.

Scope of Design and Mitigation Permit Approval

Design and Mitigation Review is a mechanism by which the City shall ensure that the design and proposed mitigation for temporary and permanent impacts of an RLRT system and facilities is consistent with:

- a. The Comprehensive Plan including without limitation Light Rail Best Practices; and the policies set forth in LUC 20.25M.010.B.7; and
- b. Any previously approved development agreement or Conditional Use Permit issued pursuant to LUC 20.25M B.1 or B.2; and

- c. All applicable standards and guidelines contained in City Codes including the procedures related to involvement of a CAC as required by LUC 20.25M.035.

**Light Rail Permitting Citizen Advisory Committee (CAC)
(LUC 20.25.030.C.2)**

Formation of a Citizen Advisory Committee (CAC) for the East Link Project was identified as necessary in the Light Rail Best Practices Final Committee Report dated June 17, 2008. The process to involve the CAC in the review of Design and Mitigation Permits is described below.

CAC Purpose (LUC 20.25M.035.A)

1. Dedicate the time necessary to represent community, neighborhood and Citywide interests in the permit review process; and
2. Ensure that issues of importance are surfaced early in the permit review process while there is still time to address design issues while minimizing cost implications; and
3. Consider the communities and land uses through which the RLRT system or facility passes, and set "the context" for the Regional Transit Authority to respond to as facility design progresses; and
4. Help guide RLRT system and facility design to ensure that neighborhood objectives are considered and design is context sensitive by engaging in ongoing dialogue with the Regional Transit Authority and the City, and by monitoring follow-through; and
5. Provide a venue for receipt of public comment on the proposed RLRT facilities and their consistency with the policy and regulatory guidance of subsection E of this section and LUC 20.25M.040 and 20.25M.050; and
6. Build the public's sense of ownership in the project; and
7. Ensure CAC participation is streamlined and effectively integrated into the permit review process to avoid delays in project delivery.

CAC Scope of Work (LUC 20.25M.035.C)

The CAC is advisory to the decision maker for the design and mitigation permits, and its scope includes:

1. Becoming informed on the proposed RLRT system or facility project;
2. Accepting comments from the public during CAC meetings for incorporation into the consolidated advice provided by the CAC to the Regional Transit Authority and the City of Bellevue;
3. Participating in context setting to describe the communities, urban and historic context, and natural environment through which the alignment passes;

4. Providing early and ongoing advice to the Regional Transit Authority on how to incorporate context sensitive design and mitigation into schematic designs for proposed project elements including stations, linear track elements, landscape development, walls (including concrete and masonry and tunnel portal), park and rides, traction power substations and other features of the RLRT system or facility; and
5. Providing advisory guidance to permit decision makers as described in more detail below regarding any RLRT system or facility design and mitigation issues prior to any final decision on required Design and Mitigation Permits, including written guidance as to whether the proposal complies with the policy and regulatory guidance of subsection E of this section and LUC 20.25M.040 and 20.25M.050.

CAC Work Product (LUC 20.25M.035.D.3)

The work of the CAC at each review stage culminates in a CAC advisory document that describes the phase of review and CAC feedback. The final Design and Mitigation Permit advisory document is intended to provide the Director of the Development Services Department with a recommendation to demonstrate Sound Transit compliance with Design and Mitigation Permit Decision Criteria pursuant to LUC 20.25M.030.C.3.

The Advisory Document prepared by the CAC for the Context Setting phase of review described in LUC 20.25M.035.C.3 is included with the staff report as Attachment A. The advisory document prepared following the Context Setting Phase of CAC review provided "context" to which Sound Transit was requested to respond when designing elements and features of the East Link light rail system and facility. The advisory document also provided the "context" by which permit compliance is judged in Section IV of the Staff Report below. Following the context setting advisory document, the CAC issued a Pre-Development advisory document which was intended to inform Sound Transit's Design and Mitigation Permit submittal (Attachment B). The CAC advisory document for the Central Bellevue Segment Design and Mitigation Permit was provided to the department director on September 29, 2015, and is included with the staff report as Attachment C. The advice provided by the CAC is included in the analysis of consistency with Light Rail Overlay design standards and guidelines contained in Section IV below.

C. Project Description

General Bellevue RLRT Alignment

The East Link Project includes approximately 14 miles of light rail track/guideway and 10 stations serving Seattle, Mercer Island, South Bellevue, downtown Bellevue, Bel Red (Bellevue), and the Overlake area in Redmond. Elements of the East Link project located within City boundaries include approximately 6 miles of new light rail track (at grade, below grade, and elevated) from I-90 to SR 520, six stations (at grade and elevated), two parking (park and ride) facilities, and other structures, facilities, and development associated with the RLRT.

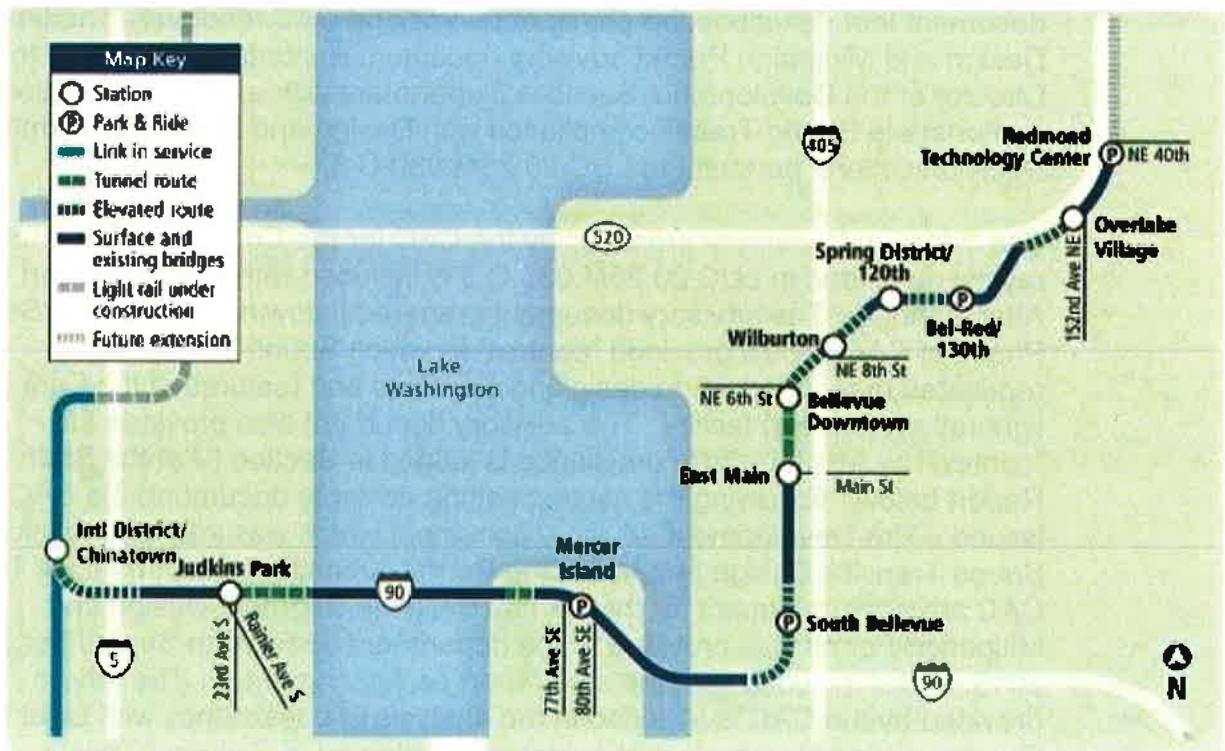

Central Bellevue Segment

The alignment for the Central Bellevue Segment commences approximately at the East Main Station at approximately SE 4th Street and 112th Ave SE to the west side of 120th Ave NE. This segment begins at grade continuing north on the west side of 112th Avenue SE where it enters the East Main Station. From the East Main Station the guideway extends north at to meet the Downtown Bellevue Tunnel South Portal wall, marking the entrance to the tunnel. In the vicinity, the South Portal Electrical Building (SPEB) building, a Traction Power Substation (TPSS), and the South Portal Lid Park comprise the South Portal Facilities. The alignment continues through the tunnel which begins on the south side of Main Street at 112th Avenue NE, continuing northwesterly passing

beneath Main Street, then curving to the north and following beneath 110th Ave NE. Just north of NE 2nd Street, there is a Mid-Tunnel Access Shaft Headhouse structure that allows maintenance access to the below grade Mid-Tunnel Fan Room. The tunnel proceeds to the north under 110th Ave NE, to the west end of the Bellevue Downtown Station located adjacent to the south side of NE 6th Street at Bellevue City Hall. From the elevated east end of the Bellevue Downtown Station, the guideway continues east in an aerial configuration and passes over city streets and a long span structure crossing of I-405. The aerial guideway then begins a gradual curve to the north until it reaches Sound Transit right of way just south of NE 8th Street. After crossing over NE 8th Street, the guideway enters the elevated Wilburton Station along 118th Avenue NE. Continuing north the guideway descends via trestle to meet existing grade still within Sound Transit right of way just west of Lake Bellevue. The guideway overpass then turns east continuing at grade to the Pine Forest and Spring District area. The guideway then enters a retained cut section and passes under 120th Ave NE. Only the surface expressions associated with the tunnel are included in this Design and Mitigation Permit application. The significant project components considered in this Design and Mitigation Permit include the following:

- a. Approximately two and a half miles of track guideway: Includes retained cut, at grade, trestle, tunnel portal, and elevated track.
- b. Three light rail stations including the East Main Station, Bellevue Downtown Station, and Wilburton Station.
- c. One South Portal Electrical Building (SPEB).
- d. One Mid-Tunnel Access Shaft headhouse.
- e. Two Traction Power Substation (TPSS) sites. One near the SPEB; and a second located along the former BNSF corridor at 120th Ave NE.
- f. Four Signal Houses.
- g. One Tunnel Portal located near the vicinity of the south side of Main Street at 112th Avenue NE.
- h. South Portal Lid Park, above the South Portal of the Downtown Bellevue Tunnel.

Figure 1. East Link Project Vicinity Map – Approximately SE 4th Street to 120th Avenue NE

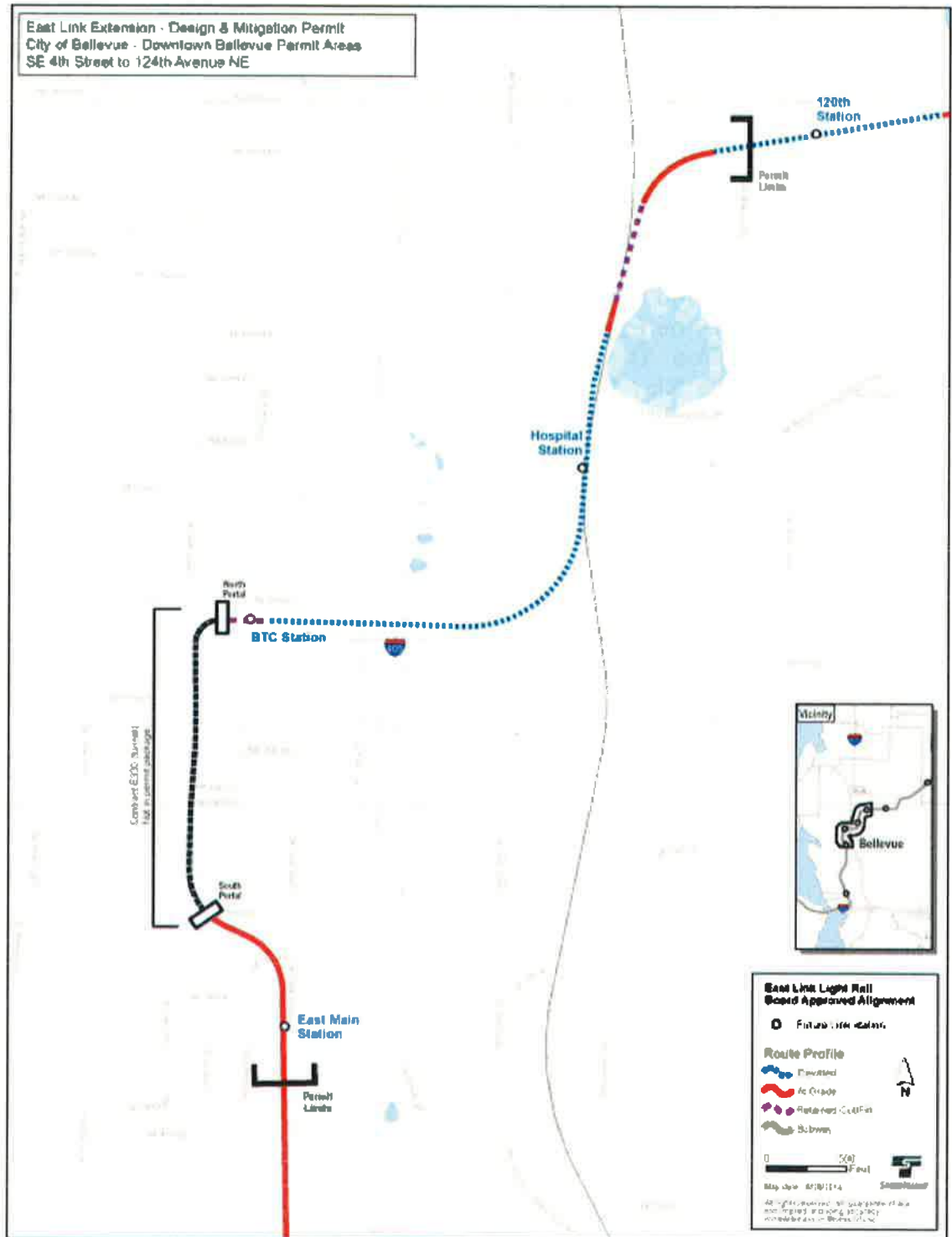

D. Stations and Supporting Structures

East Main Station

Concept: The East Main Station design was inspired by the mid-century modern architecture of the adjacent Surrey Downs neighborhood. It is intended to be visually distinctive yet unobtrusive and residentially scaled with roof forms reminiscent of the neighborhood. The material for the station is primarily stainless steel with a cut-out screen wall at the ticket vending locations intended to recall graphic patterns often used in mid-century modern design. The landscape design further reinforces the mid-century modern connection with species characteristic of landscape design from that period.

Site Description: The East Main Station is located south of the intersection of 112th Avenue SE and Main Street, on the west side of 112th Avenue SE. It is an end-loaded side platform station, with its primary entry via a public plaza at the north end of the station, and a secondary entry off a smaller plaza at the south end of the station. Each entry is served by two ticket vending machines, associated with signage, card readers, passenger telephones, and other facilities included for riders' convenience. The ticket vending areas are covered by glass canopies that extend to cover the entries.





Bellevue Downtown Station

Concept: The Bellevue Downtown Station is intended to complement the Bellevue Transit Center bus station's architecture, particularly the "tree column" motif, variations of which occur on several significant Bellevue public buildings, including the public library. Continuity between the City Hall plaza and station is achieved through use of hardscape and landscape patterning.

Site Description: The Bellevue Downtown Station is located between 110th Avenue NE and 112th Avenue NE, just south of, and parallel to, NE 6th Street. The primary or west station entry is at the corner of 110th Avenue NE and NE 6th Street. A secondary east entry is located at the corner of NE 6th Street and 112th Ave NE. The station shares the block with Bellevue City Hall which occupies the southern half of the block. The station is located diagonally across 110th Ave NE from the Bellevue Transit Center bus station, and the pedestrian connection between the two facilities forms a critical relationship in the multi-modal transportation network within the city. The primary material of the station is cast-in-place concrete, with terra-cotta cladding on the west elevator enclosures that relates to the terra-cotta used on Bellevue City Hall.





Wilburton (Hospital) Station

Concept: The station entries for the Wilburton Station are designed to be beacons of color, acting as wayfinding cues for passengers approaching on foot or by car to provide passengers with an immediate understanding of the station configuration and its dual points of entry. The landscaping concept at this station is a formal, urbanized tree scape. Landscaping on the west side is dictated by the naturalistic form of Sturtevant Creek and is developed to provide a visual overlook into the restored stream area for patrons entering the station from either end.

Site Description: The Wilburton Station is located in the former BNSF right-of-way just west of 118th Ave NE and north of NE 8th Street. There is a large entry plaza below the station that extends for the length of the station, and a vehicle drop off area to the east along 118th Avenue NE. The station platform is an elevated center platform accessed by three public stairs and two elevators connecting the plaza level to the platform. Station entries are marked with brightly colored aluminum panels that envelop the walls, and floating ceilings. The platform includes three sections of canopy, wind screening with seating, and passenger information panels in a designated waiting area at the center of the platform.

Hospital Station



Site Plan

Hospital Station 



Station View Looking Northwest

Hospital Station 



Platform View Looking South

Supporting Structures: The safe and efficient operation of a light rail system relies upon a number of components in addition to the track, guideway, and stations. These essential system elements house the equipment needed to supply power to the vehicles, ensure that warning signals and communications equipment function properly, and provide necessary access to system elements.

South Portal

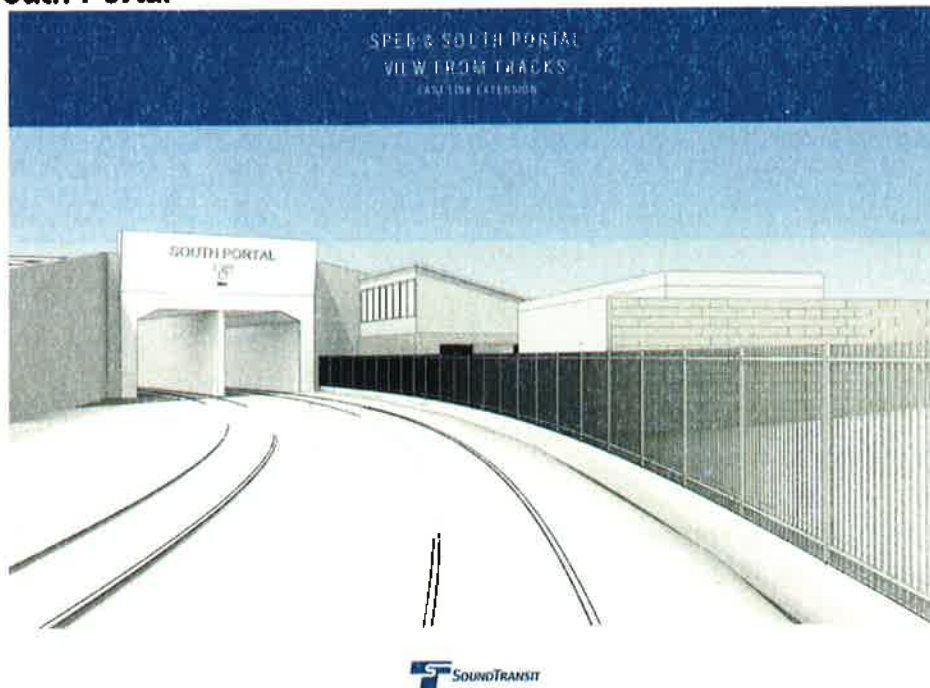

SPEB

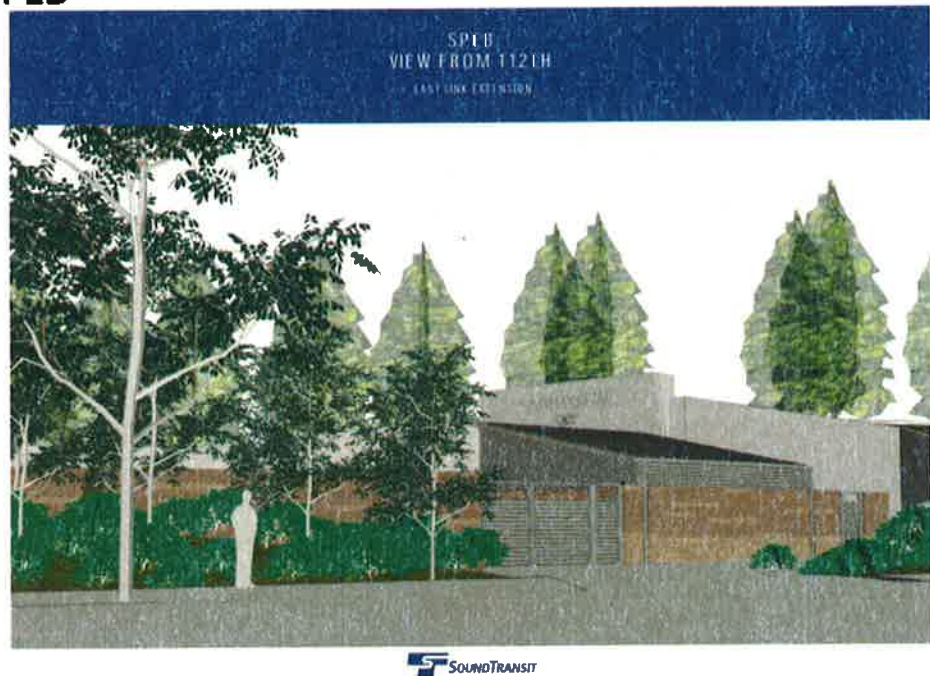

Access Shaft Headhouse

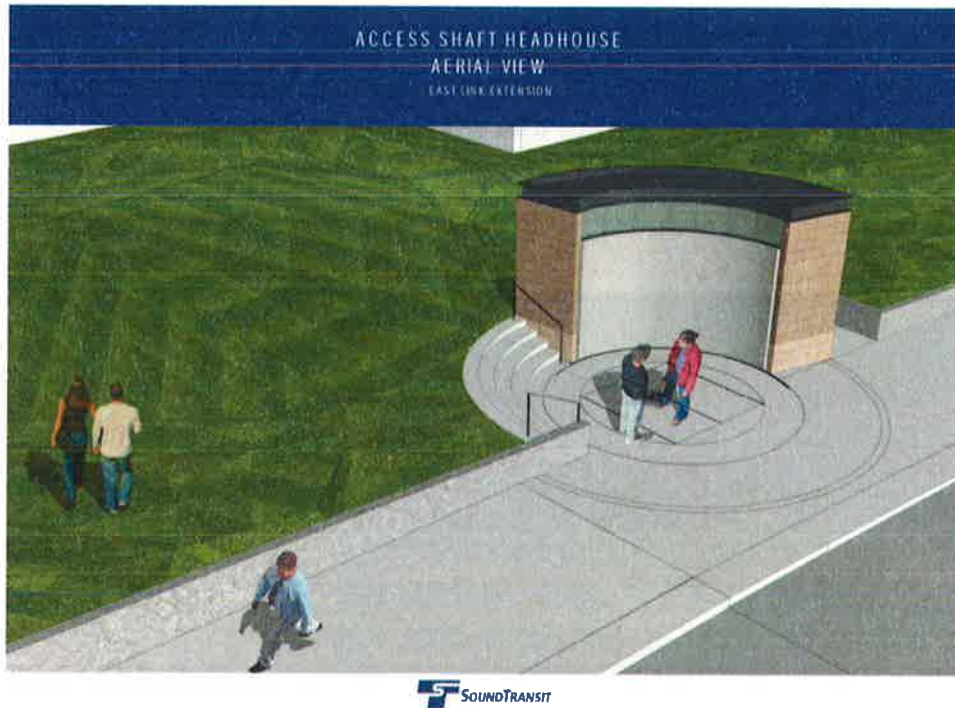

II. ZONING AND CONTEXT

The project alignment for this segment passes through several zoning districts. These districts include R-4, R-20, Downtown OLB, OLB, GC, BR-GC, BR-MO-1, BR-R, and BR-OR-2.

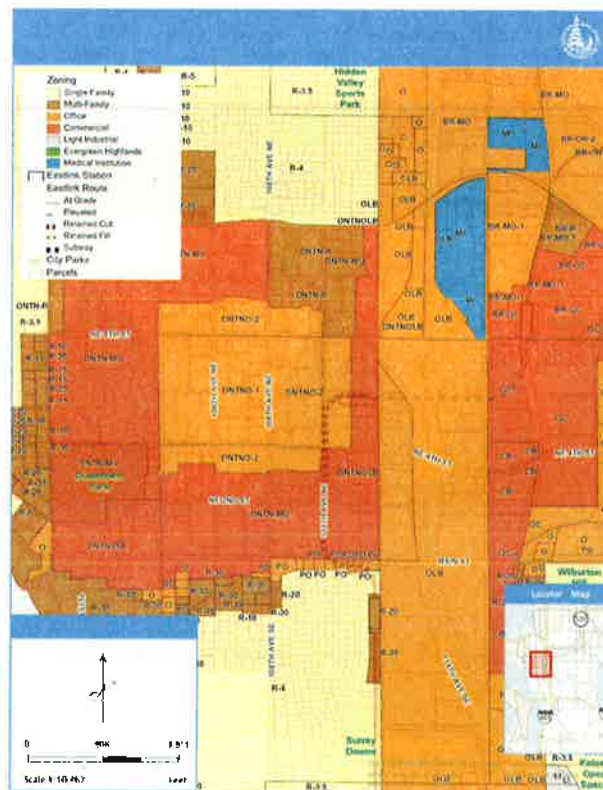

Design Intent – Southwest Bellevue Subarea - In addition to complying with all applicable provisions of the Southwest Bellevue Subarea Plan, the design intent for the Regional Light Rail Train system and facility segment that passes through this subarea is to contribute to the major City gateway feature that already helps define Bellevue Way and the 112th Corridor. The Regional Light Rail Transit system or facility design should reflect the tree-lined boulevard that is envisioned for the subarea, and where there are space constraints within the transportation cross-section, design features such as living walls and concrete surface treatments should be employed to achieve corridor continuity.

Design Intent – Downtown Subarea - In addition to complying with all applicable provisions of the Downtown Subarea Plan, the design intent for the RLRT system and facility segment that passes through this subarea is to enhance Downtown Bellevue's identity as an urban center that serves as the residential, economic, and cultural heart of the Eastside. The above-ground expression of the Downtown Station is envisioned as a highly utilized urban "place" with an architectural vocabulary that not only reflects and communicates the high quality urban character of Downtown as a whole, but also complements the immediately adjacent civic center uses including Bellevue City Hall, Meydenbauer Convention Center, the Transit Center, Pedestrian Corridor, and the Downtown Art Walk. The alignment crossing over I-405 will be prominent to visitors entering, leaving, and passing through the Downtown, and its design should be viewed as an opportunity to create a landmark that connects Downtown Bellevue with areas of the City to the east. The station and freeway crossing should reflect Bellevue's branding, and should be comfortable and attractive places to be and experience, with high quality furnishings and public art that capitalize on place-making opportunities.

Design Intent – Wilburton/NE 8th Street Subarea - In addition to complying with all applicable provisions of the Wilburton/N.E. 8th Street Subarea Plan, the design intent for the RLRT system and facility segment that passes through this subarea is to focus on the hospital station's role as a gateway location to points east of Downtown on to Bel-Red and beyond. The alignment crossing over I-405 should create a cohesive connection between the Downtown and hospital stations, but the hospital station itself should have its own identity. With significant ridership anticipated to be generated from the Medical Institution District to the west, the hospital station should take design cues from the hospital, the ambulatory health care center, and the medical office buildings that were designed to be responsive to the Medical Institution Design Guidelines that are shaping the character of this area.

The CAC was tasked with evaluating the existing context setting characteristics included in the Land Use Code in order to verify that the design of the stations and alignment is consistent with the vision for the Southwest Bellevue, Downtown, and Wilburton/NE 8th Street Subareas. The Land Use Code at 20.25M.050.B states that the character of these areas is defined as follows:

Southwest Bellevue

- The expansive Mercer Slough Nature Park;
- Historic references to truck farming of strawberries and blueberries;
- Retained and enhanced tree and landscaped areas that complement and screen transportation uses from residential and commercial development; and
- Unique, low density residential character that conveys the feeling of a small town within a larger City.

Downtown Subarea

- Private entertainment and cultural attractions;
- High quality urban amenities such as pedestrian oriented development and weather protection that encourages people to linger and not just pass through;
- High rise buildings that attract a creative and innovative work force;
- Multifamily developments that attract urban dwellers that are less tied to their vehicles to accomplish day-to-day tasks;
- Great public infrastructure including roadways, transit and pedestrian improvements, parks and public buildings; and
- Stable property values that make it a desirable place for businesses to locate and invest.

Wilburton/NE 8th Street

- Outdoor spaces that promote visually pleasing, safe, and healing/calming environments for workers, patients accessing health care services, and visitors;
- Buildings and site areas which include landscaping with living material as well as special pavements, trellises, screen wall planters, water, rock features, art, and furnishings;
- Institutional landmarks that convey an image of public use and provide a prominent landmark in the community; and
- Quality design, materials, and finishes to provide a distinct identity that conveys a sense of permanence and durability.

Finding: The CAC advised that the following additional context and design considerations should be considered when evaluating the East Link project in the Southwest Bellevue, Downtown Bellevue, and Wilburton/NE 8th Street Subareas for context sensitivity during future CAC and permit review phases. The following items pertain to the Central Bellevue Segment:

Southwest Bellevue

- Along 112th SE design treatments and mitigation should be complementary to differing levels of development intensity that exist on the east (commercially developed) and the west (residentially developed) sides of the road.
- The portal and tunnel between the East Main and Downtown Stations present an opportunity to “Visually Transport” transit riders from the historic mid-century modern, stable neighborhoods of Southwest Bellevue to the bustling urban context of the Downtown. Art on the portal and in the tunnel could help depict the transition from the suburban context to the urban context.
- Landscaping should be employed to soften the impact of the portal structure adjacent to the East Main Station. If art opportunities are employed, additional emphasis on the concrete mass of the East Main portal structure should be avoided.

Downtown Subarea

- The Downtown Station should convey a sense of arrival at a bustling economic hub that provides access to retail, visitor services, offices, and urban residential neighborhoods.
- The station should convey a future focus on smart growth, and the importance of transit to the success of sustainable development.
- The aesthetics of the station roof should be taken into account and finished to enhance views down on the Downtown station for adjacent high rise and convention center development.
- Clear connectivity, accessibility, and way finding should be provided between the Downtown Station and the Bus Transit Center.

Wilburton/NE 8th Street Subarea

- Height of the flyovers (freeway, 116th Ave NE, and NE 8th) between the Downtown Station and the Wilburton (Hospital) Station presents unique opportunities and challenges.
 - i. Design attention should be given to the under-portions of the flyover structures that will be visible from vehicles and pedestrians that pass underneath them.

- ii. Required railings on the flyover structures could present an art opportunity if they could be employed without further emphasizing the mass of the structure.
- The aesthetics of the Wilburton (Hospital) station roof should be taken into account and finished to enhance views down on the station for adjacent development on Midlakes Hill to the east and future development anticipated in the Wilburton Village.
- Clear connectivity, accessibility, and way finding should be provided between the Hospital Station and the Medical Institution District where Overlake Hospital and the Group Health Ambulatory Care Center are located.
- Weather protection should be provided on the route between the Wilburton (Hospital) Station and the Medical Institution District.
- References to the freight hub and rail platform that served Bellevue's historic truck farming industry should be incorporated into the Wilburton (Hospital) Station.
- The Wilburton (Hospital) Station context should convey a sense of institutional permanence and quality that is broader in focus than accessibility to health care.

III. CONSISTENCY WITH ZONING REQUIREMENTS

Use (LUC 20.25M.030.A)

The proposed East Link RLRT facility is considered a permitted use under LUC 20.10.440 if the City Council has approved the facility system by resolution, ordinance, or development agreement (see LUC 20.10.440 "Transportation and Utilities" Footnote 25). The Bellevue City Council has approved the East Link RLRT facility and alignment through Resolution No. 8576, therefore, it is an allowed use subject to design and mitigation review and shoreline permitting.

IV. DESIGN STANDARDS AND GUIDELINES

20.25M.040 RLRT System and Facilities Development Standards

A. Purpose and Applicability

The RLRT system and facilities are a unique form of essential public facility that is linear in nature, passing through numerous land use and overlay districts, following a route into and out of Bellevue that connects multiple jurisdictions and regional employment and cultural centers. The purpose for including development standards in the Light Rail Overlay is to provide specific requirements for mitigation of impacts created by an RLRT system or facility in land use districts where overlay requirements do not exist or where overlay requirements did not contemplate a light rail use.

B. Dimensional Requirements

1. Height Limitations – Determined Based on Use Approval Process.

- a. Use Approved through Development Agreement. When an RLRT system or facility use has been permitted outright in a City Council resolution, ordinance, or development agreement pursuant to LUC 20.25M.030.B.1, the heights approved by Council action shall be permitted.

Finding: The Bellevue City Council passed Resolution No. 8576 including the alignment and profile for the East Link segments through Bellevue on April 22, 2013. The heights for the structures within this permit are consistent with the intended heights of structures contemplated by Resolution No. 8576 and therefore satisfy Land Use Code requirements for height.

2. Setbacks.

- a. Requirement. The minimum setback for structures shall apply as set forth for each land use district. In an RLRT transition area, a 30-foot setback is also required from RLRT facility structures and from at-grade or elevated track.
- b. Exceptions. The following RLRT facility components are exempted from the requirement to provide a setback.
 - ii. Noise walls, fences and retaining walls; and
 - ii. Structures allowed in landscape screening areas and installed consistent with the requirements of subsection C.3.b of this section.

Finding: A very small amount of the Central Bellevue Segment of East Link is located within the RLRT transition area south of Main Street, therefore, a 30-foot setback is required from RLRT facility structures and from at-grade or elevated track. The plans submitted in support of this permit application verify that proposed RLRT facilities and structures as well as the track satisfy the minimum 30 foot setback requirement. In addition to the setback requirement, specific landscape planting requirements are also applicable in the RLRT transition area. See Section C below for a discussion of landscape requirements.

3. Structure Separation Requirement

In an RLRT transition area, for at-grade or elevated track, a minimum separation of 60 feet is required between the edge of the track-way nearest the existing residential primary structure and an existing residential primary structure.

Finding: The portion of the Central Bellevue Segment which runs along the west side of 112th Ave SE is located in the RLRT transition area and requires 60 feet of separation from any portion of an existing primary residential structure to the edge of the nearest track-way. **See Section XI for a related condition of approval.**

C. Landscape Development Requirements (LUC 20.25M.040.C)

1. General

Applicability

In Light Rail Overlay District areas not located within the Downtown Overlay District or Bel-Red Overlay District, landscape development for an RLRT system or facility shall be provided as described in this subsection.

Purpose/Intent

- Purpose/Intent of the Landscape Development Requirements.
 - i. Landscape screening is intended to provide a dense sight barrier to significantly separate and obscure higher intensity uses from lower intensity uses.
 - ii. Landscape buffers are intended to provide visual relief and softening of transportation facilities where preservation of sight lines is important.
- Additional Provisions.
 - i. All required landscape development shall be context sensitive and shall be reviewed by the CAC as provided for in LUC 20.25M.035.
 - ii. RLRT systems and facilities proposed under the terms of this overlay should to the maximum extent feasible retain existing significant vegetation in order to soften the visual impact on adjacent properties.
 - iii. All landscape screening and buffers shall comply with the provisions contained in LUC 20.20.520.F.5 through F.8, G, I and J.
 - iv. Landscape development required by this section shall be installed and maintained pursuant to the guidance set forth in the Environmental Best Practices and Design Standards (Bellevue Parks Department 2006), now or hereafter amended.

Finding: As discussed in the context setting CAC Advisory Document, the

CAC had extensive review of proposed landscape elements and provided minimal advice for modifications to be incorporated into construction plans. As a priority, the city has worked collaboratively with Sound Transit to retain as much existing vegetation and trees to provide visual relief and to soften the visual impacts of this linear project. According to the E330/E335 Tree Removal and Mitigation Analysis Addendum submitted by Sound Transit as part of this application, the following tree impacts and mitigation are proposed.

Table 3.0-1 – E330/E335 Tree Removal and Mitigation Summary

E330/E335 Tree Removal	Light Rail Overlay Areas	Critical Areas		Critical Area Buffer	
		Coniferous	Deciduous	Coniferous	Deciduous
Total Trees		1,175			
Trees by District	1,063	1	19	19	73
Total Trees Removed		345			
Trees Removed by District ¹	270 ² (+4 hazard)	1	19	7	48
Estimate of Total Trees Necessary for Mitigation³		91			

1. Tree counts, rather than DBH, are reported in these columns, for purposes of consistency between critical areas, critical area buffers and non-critical areas. On non-critical areas within the city of Bellevue, mitigation is based on DBH. Notes on the DBH are provided below, based on the data on trees removed within Light Rail Overlay Areas.
2. Of the 9,415" of existing tree DBH located within Light Rail Overlay Areas, (includes trees to remain as well as trees that will be removed) 2,169" DBH will be removed by the Project.
3. This number was determined by applying the tree replacement ratios to the number of trees removed within each of the relevant areas.

Of the 1,175 existing trees located within the Central Bellevue Segment, 345 will be removed by the project, and 830 will be retained.

Table 3.0-2 – E330/E335 Tree Replanting Summary – Proposed Corridor/Station and Mitigation Plantings

E330/E335 Tree Replacement	Corridor and Station Plantings	Mitigation/Restoration Area Plantings ⁴	
		Coniferous	Deciduous
Proposed Trees to be Planted	529	0 ⁵	34
Total Trees to be Planted⁶		563⁷	

4. Estimates of tree proposed in mitigation areas assume 1% of all 2-Gal. plants in the 50% cost estimate.
5. Due to space planting space limitations, there are limited opportunities to plant coniferous trees in environmental mitigation planting areas along the E330/E335 corridor.
6. This is a summary of all trees to be planted within proposed landscape areas.
7. Includes 161 coniferous trees to be planted along the corridor, at stations and at the Main St. Park.

A total of 563 trees are proposed for mitigation planting. This includes 529 trees within corridor and station planting areas and 34 deciduous trees for critical area and critical area buffer impacts. Approximately 161 coniferous trees will be planted along the corridor, at stations, and at the new Main

Street Park.

Landscape Screening of Nonlinear Facility Components

- Type and Minimum Depth of Landscaping Screening
 - i. Traction power substations (TPSS) and other above ground nonlinear RLRT facility components shall be screened with 10 feet of Type I landscaping pursuant to the requirements of LUC 20.20.520.G.1.
 - ii. Park and ride (public parking lot not serving a primary use) and storage track and support facilities shall be screened with 15 feet of Type I landscaping pursuant to the requirements of LUC 20.20.520.G.1.
- Maintenance of Landscape Screening. Landscape screening is required to be maintained by the Regional Transit Authority for the life of the project. Maintenance of landscape screening may be reassigned pursuant to voluntary written agreement filed with the Development Services Department and King County Recorder's Office or its successor agency.

Finding: The TPSS located near the South Tunnel Portal is located within an enclosure and receives additional screening from adjacent landscape plantings. Visual impacts are also mitigated by topography as the TPSS sits below the street level. The second TPSS is near the storage tracks near the old BNSF corridor.

The East Main Station landscaping is intended to satisfy City of Bellevue streetscape requirements and has a planting palette intended to relate to its context adjacent to the Surry Downs neighborhood. Landscaping in the area will provide a visual buffer between adjacent properties and the noise wall west of the station.

Landscaping at the Bellevue Downtown Station responds to the adjacent Bellevue City Hall and Plaza in a highly urbanized environment. The landscape plan incorporates many of the existing public art elements currently located in the plaza.

Landscaping at the Wilburton Station is intended to be more natural with the restored Sturtevant Creek as a primary feature. New formal landscaping is focused around the parking and drop off areas on the east side of the station. Two new street trees will be planted along NE 8th Street. Silva Cells will be used in this location to support soil demands for new trees.

Landscape Screening and Buffers Adjacent to Linear Alignment

- Type and Minimum Depth of Landscape Screening and Buffers.
 - i. Light rail alignment abutting transportation right-of-way shall include frontage landscaping to soften, and separate where feasible, pedestrian facilities from light rail and transportation uses.
 - (1) Pedestrian facilities located between the light rail use and the transportation right-of-way shall be buffered with four feet of frontage landscaping installed in a planter strip pursuant to the following standards:
 - (a) Preferred location of the planter strip is between the light rail alignment and the sidewalk, but may be relocated to the opposite edge of the sidewalk to avoid conflicts between required street trees and the light rail overhead catenary system or underground utilities.
 - (b) Street trees shall be installed in the planter strip and shall be at least three inches in caliper, planted three feet from any street curb, and a maximum of 25 feet on center unless modification is necessary to meet sight distance requirements of BCC 14.60.240.
 - (c) Shrubbery, groundcover and other approved plantings, except turf, are required in the planter strip along the length of the frontage.
 - (2) Pedestrian facilities located between the light rail use and property developed in a nonresidential or residential use shall be buffered with four feet of frontage landscaping installed in a planter strip pursuant to the following standards:
 - (a) Preferred location of the planter strip is between the light rail alignment and the sidewalk, but may be relocated to the opposite edge of the sidewalk to avoid conflicts between required street trees and the light rail overhead catenary system or underground utilities.
 - (b) Planter strips located adjacent to landscape screening required pursuant to subsections C.3.a.ii and iii of this section are not required to be physically separated from the required landscape screening area.
 - (c) The requirements of subsections C.3.a.i.(1)(b) through (c) of this section shall be met irrespective of the planter strip location.

- ii. Outside an RLRT transition area, light rail alignment abutting private property shall be screened with 20 feet of Type I landscaping which meets the requirements of LUC 20.20.520.G.1.
- iii. Within an RLRT transition area, light rail alignment abutting private property shall be screened with 30 feet of Transition Area Design District landscaping which meets the planting requirements of LUC 20.25B.040C.2.c. Landscape screening provided under the terms of this subsection shall be placed within the required 30-foot setback from the RLRT track alignment.

Finding: Corridor landscape plans are intended to provide a landscape continuity which will provide an aesthetic enhancement to adjacent neighborhoods. Corridor landscaping for the Central Bellevue Segment is intentionally a simple palette to reflect the highly urbanized nature of Downtown and immediately adjacent environment.

The landscaping proposed in corridor areas includes a range of sizes of deciduous trees that will generally be between 5 to 7 feet in height at planting. Proposed conifers are between 10 to 12 feet in height at planting.

Sound Transit has provided 30 feet of Transition Area Design District landscaping within the RLRT transition area adjacent to the residential development on the west side of 112th Ave SE in the vicinity of the East Main Station. Placement of trees was done in consideration of light rail tree clear zone requirements. Trees to be planted in the buffer include Western Red Cedar (*Thuja Plicata*), Douglas Fir (*Pseudotsuga Menziesii*), Greenspire Littleleaf Linden (*Tilia Cordata* 'Grenspire'), and Red Sunset Maple (*Acer Rubrum* 'Franksred').

- Non-Plant Material Allowed in Landscape Buffer and Screening Areas. Fences, walls, noise attenuation barriers, sidewalks and multi-purpose paths, structures with a footprint of 100 square feet or less and less than 10 feet in height, and landscape features such as decorative paving, grating, sculptures, or rock may be located within a required landscape buffer or screening area; provided, that the area devoted to such a feature may not exceed 20 percent of the required area.
- Ownership of Landscape Screening. Landscape screening located within the required 30-foot setback from the RLRT track alignment is owned by the Regional Transit Authority. The landscape screening located outside the required setback from the RLRT track alignment may be located on property owned in fee by a Regional Transit Authority, on an easement, or on private property where access entry was secured for landscape installation.

- Maintenance of Landscape Screening. Landscape screening is required to be maintained by the Regional Transit Authority for the life of the project. Maintenance of landscape screening may be reassigned to the underlying property owners pursuant to a voluntary written agreement filed with the Development Services Department and King County Recorder's Office or its successor agency.

Finding: The allowed non-plant material that is located within landscape areas constitutes much less than 20 percent of each area. There is one noise wall located within the 30 foot RLRT Transition Area Buffer. Sound Transit will own the landscaping in the 30 foot buffer, and maintenance will be provided by Sound Transit unless a voluntary written agreement has been filed.

See Section XI for related landscape planting and maintenance conditions of approval.

CAC Design and Mitigation Permit Advice

Landscaping

- The CAC recommends that landscape development at the Wilburton (Hospital) Station, particularly in the vicinity of NE 8th Street, be designed in a way which does not create a site obstruction for motorists.
- The CAC recommends that vegetation retention should be maximized north of the Wilburton (Hospital) Station to provide a buffer to adjacent residential development.

Finding: Sound Transit is required to use AASHTO design guidelines for sight distance found in the Policy on Geometric Design of Highways Streets manual. These guidelines are intended to ensure adequate sight distances for motorists, pedestrians, bicyclists, and other street users based on the design speeds of NE 8th Street. Developing to these guidelines should ensure there are not site obstructions for motorists and other users of the street.

To the greatest extent technically feasible, all viable vegetation that does not conflict with guideway and minimum clearance requirements should be maintained. Some vegetation will be removed in and around Sturtevant Creek for mitigation purposes.

Fencing

Fencing shall be required to meet the applicable requirements of LUC 20.20.400 when overlay standards and/or design guidelines have not been incorporated by reference in LUC 20.25M.010.D. Any fencing shall be

context sensitive.

- Security and safety fences should be designed to meet City's codes. These fences should be designed to minimize blocked views to maintain the idea of a city in a park.

Finding: No prohibited fences will be approved with this application. The required security fencing has been designed to have a more residential character and color. More standard fencing will be located near the restored Sturtevant Creek stream buffer to keep people away from mitigation planting.

Light and Glare

1. To protect adjoining uses and vehicular traffic in the right-of-way, the following provisions shall apply to the generation of light and glare from RLRT facilities:
 - a. All exterior lighting fixtures in parking areas and driveways shall utilize cutoff shields or other appropriate measures to conceal the light source from adjoining uses and rights-of-way. Other lights shall be designed to avoid spillover glare beyond the site boundaries.
 - b. Interior lighting in parking garages shall utilize appropriate shielding to prevent spillover upon adjacent uses and the right-of-way.
- The CAC recommends that no stations should have up lights that could shine into neighboring buildings or residential areas. All lighting should remain within the confines of the stations to the greatest extent possible.
- The CAC recommends that the issue of lighting be uncoupled from the issue of meeting the needs of those with disabilities and that both audio and visual cues be included in station design.

Finding: Sound Transit has lighting standards that are intended to prohibit up lighting and control site lighting to prevent spillover into neighboring properties.

Mechanical Equipment

Mechanical equipment shall be required to meet the applicable requirements of LUC 20.20.525 when overlay standards and/or design guidelines have not been incorporated by reference in LUC 20.25M.010.D. Any mechanical equipment screening shall be consistent with the landscape development requirements of subsection C of this section and shall be context sensitive. **See Section XI for a related condition of approval.**

Recycling and Solid Waste Collection

1. Solid waste and recyclable material collection areas shall be provided for workers maintaining and operating an RLRT facility consistent with the terms of LUC 20.20.725.
 2. Solid waste and recyclable material collection receptacles shall also be provided for the public who access the station and park and ride facilities of an RLRT system.
- The CAC recommends that Sound Transit work with its sustainability group to evaluate a system wide compost collection bin option at its stations.

Finding: Sound Transit provides both waste and recycling bins at each of their stations. These are available to both workers and members of the public and are typically small ground-based units that do not require additional screening. Sound Transit may begin a composting program in the future as directed by its sustainability unit.

Critical Areas

- The CAC recommends that the city insure that Sound Transit adhere to all applicable water quality and storm drainage requirements.

Resources Defined/Intent

As required by the Washington State Growth Management Act (RCW 36.70A) the City of Bellevue regulates critical areas through the Critical Areas Overlay District under City of Bellevue Land Use Code (LUC) section 20.25H. The Critical Areas Overlay District is a mechanism by which the City recognizes the existence of natural conditions which affect the use and development of property. Through this part, the City designates and classifies ecologically sensitive and hazard areas and imposes regulations on the use and development of affected property in order to protect functions and values and ensure public health, safety and welfare. Critical Areas promulgated by RCW 36.70A and established by LUC 20.25H include Streams, Wetlands, Geologic Hazard Areas, Areas of Special Flood Hazard, Shorelines, and Habitat for Species of Local Importance.

Small segments of the Central Bellevue (E335) segment cross through or are adjacent to regulated critical areas and their buffers. This section of the staff report outlines the results of extensive field study, identifies anticipated impacts, presents proposed mitigation measures as required to offset impacts, and imposes conditions intended to ensure appropriate long term objectives and desired outcomes are achieved.

Critical Areas Land Use Permit

Although the proposed project will impact critical areas and critical area buffers a Critical Areas Land Use Permit is not required. In accordance with LUC 20.25M.030.C.3.j when a proposed RLRT facility (or associated infrastructure and mitigation) is to be located wholly or partially in a defined and regulated critical area (or buffer), a Critical Areas Land Use Permit is not required and analysis of project compliance with LUC 20.30P is not applicable. Compliance with the requirements of LUC 20.25H (Critical Areas Overlay District) shall be demonstrated and bundled with the project Design and Mitigation Permit. In addition to performance standards and criteria established in the Critical Areas Overlay District, compliance with criteria established in LUC 20.25M.030.C.3.j is also required.

Critical Areas Field Study Reports and Critical Areas Report Defined

i. Wetland, Stream, and Jurisdictional Ditch Delineation Report

The Central Bellevue (E335) Segment design package intersects wetland resources and stream resources. The applicant, Sound Transit, has consulted with Anchor QEA (a qualified consultant - LUC 20.25H.030, LUC 20.25H.250.B, and LUC 20.50.042) to develop a Wetland, Stream, and Jurisdictional Ditch Delineation Report (the '**Delineation Report**' – **See Attachment D**) that documents the presence, location, and quality of stream and wetland critical areas within proximity of the proposed Sound Transit RLRT facility. The Delineation Report was developed for the entirety of the Sound Transit East Link RLRT alignment, from Lake Washington/I-90 to the Redmond border and its associated design packages. This report also includes a summary of jurisdictional ditches, although this section is not relevant to City of Bellevue permit review (the City of Bellevue Land Use Code does not regulate jurisdictional ditches), this section was included as the Delineation Report is also used with application for state and federal permit and the applicant opted to create one report for the whole project that is universal across all required permit paths.

The Delineation Report was developed after extensive field work to locate and characterize wetlands and streams within proximity to the proposed East Link alignment. City of Bellevue Development Services Department Land Use Division staff were involved closely with the development of this report and inconsistencies with application of delineation practice and interpretation of City of Bellevue Land Use Code Critical Areas requirements were resolved through correspondence and field meeting with the applicant and consultant, including engagement of the State Department of Ecology where needed.

The Report analyzes regulatory requirements, includes detailed maps depicting the location of the subject resources, and memorializes the study methodology. This report was used in support of the project Critical Areas Report (see below) and is the fundamental baseline establishing existing wetland and stream conditions in the project vicinity. **The project Delineation Report is included as Attachment D.**

ii. East Link Light Rail Extension Critical Areas Report and Mitigation Plan

The East Link Light Rail Extension Critical Areas Report and Mitigation Plan (the '**Critical Areas Report**' – **See Attachment E**) was developed following completion of the project Delineation Report (see above). The Critical Areas Report documents existing conditions within the vicinity of the project alignment, identifies anticipated impacts to known resources, analyzes regulatory requirements, presents mitigation measures designed to offset and abate identified impacts, and includes long term mitigation objectives and contingencies. The Critical Areas Report presents a plan for regulatory compliance and establishes a vision for long term outcomes.

It is anticipated that additional analysis may be needed as the project design is refined through continued project design efforts (e.g. CAC, City Council, Design and Mitigation Permit, Engineering, etc.), and the Critical Areas Report was specifically designed to allow for updates as new information becomes available or to address minor project changes. The most recent version of this report was issued in June of 2015 and submitted to the City's Permit Center as a revision to the Design and Mitigation Permit reviews.

With this Design and Mitigation Permit, compliance with Critical Areas requirements established in LUC 20.25H and LUC 20.25M is demonstrated through the project Critical Areas Report. This section of the staff report is a summary of the findings of the Critical Areas Report. Where statements of compliance with Critical Areas requirements are made in this staff report, they are based on information and analysis presented in the Critical Areas Report. Impacts associated with Sound Transits Central Bellevue (E335) Segment (also referred to as the E335 Contract Design Package) are outlined in Appendix F.2 of the Critical Areas Report. **The Critical Areas Report is included as Attachment E.**

Analysis of Technically Feasible Alternatives – Not Required

As an Essential Public Facility (EPF), the proposed East Link RLRT facility is an allowed use within the Critical Areas Overlay District (LUC 20.25H) established by LUC 20.25H.055.B, Footnote 12. In accordance with LUC 20.25M.040.I.2, as an EPF, when an RLRT facility alignment location and profile is approved by the City Council pursuant to resolution or ordinance, analysis of technically feasible alternatives is not required and LUC 20.25H.055.C.2.a does not apply. Sound Transit (the applicant) is not required to demonstrate that the selected alignment location and profile is the alternative with the least impact to critical areas, because the Bellevue City Council passed Resolution No. 8576 including the alignment location and profile on April 22, 2013, and the East Link RLRT facility as proposed in this application is consistent with the Council resolution. Although Sound Transit is not required to consider alternative alignments, in accordance with LUC 20.25M.030.C.3.j.i the design must result in the least possible impact on critical areas based upon the agreed upon alignment chosen by the Bellevue

City Council and Sound Transit Board. The applicant has provided an analysis of design considerations that complies with this requirement as part of the project Critical Areas Report (included as **Attachment E**).

Compliance with Performance Standards and Criteria

As the proposed Sound Transit RLRT facility intersects with critical areas, compliance with applicable performance standards and criteria must be demonstrated. Applicable performance standards are outlined in LUC 20.25H.055.B and further refined in LUC 20.25M.030.C.3.j and LUC 20.25M.040.I. A Critical Areas Land Use Permit is not required and compliance with LUC 20.30P does not apply. The applicant has provided an analysis of compliance with applicable performance standards that complies with this requirement as part of the project Critical Areas Report (included as **Attachment E**).

Modification of Standards

Due to the complex design of an RLRT facility, strict application of critical areas rules may not be feasible or practical. In many instances application of prescriptive rules may cause for an adverse or un-intended impact or outcome. To address situations where conflict has been identified, a modification of critical areas standards is allowed, with the criteria established by LUC 20.25M.060, and LUC 20.25M.040.I.1 which together provides for modification of the requirements of LUC 20.25H.

Mitigation Plan

Although a Critical Areas Land Use Permit is not required, as specified by LUC 20.25M.030.C.3.j (see discussion above), a mitigation plan meeting the requirements of LUC 20.25H.210 must be submitted with the Design and Mitigation Permit application. The applicant has submitted a mitigation plan, designed by a qualified professional, included as part of the project Critical Areas Report (see **Attachment E**) and meeting the requirements of LUC 20.25H.210.

Linear Project

Sound Transit's East Link project is linear. As a linear project, East Link intersects multiple resource areas classified as Critical Areas by the City's Land Use Code Critical Areas Overlay District. For the purpose of this Design and Mitigation Permit, analysis is focused on impacts and mitigation measures associated with the Central Bellevue Segment. Due to association with a larger linear project, the point of origin and the point of termination of the project limits are dictated by the larger linear alignment. The Central Bellevue (E335) Segment must be compatible and connect with the segments to the north and south, and must follow the alignment established by planning efforts made by Sound Transit and the City of Bellevue. Construction of the Central Bellevue (E335) segment of Sound Transit's East Link facility is reliant on a critical areas mitigation plan that establishes consolidated mitigation for the entire East Link Segment through Bellevue. Specific portions of the overall East Link mitigation package will be constructed within

the Central Bellevue (E335) Segment, while other mitigation measures required due to impacts associated with the Central Bellevue (E335) Segment will be constructed outside the limits of the Central Bellevue (E335) Segment.

Deployment of the mitigation plan is dependent on installation of mitigation associated with the phased construction approach taken by Sound Transit for the entire Bellevue segment of the East Link project. See associated conditions of approval requiring implementation of the complete mitigation plan.

Watershed Basins

The Central Bellevue (E335) segment of the East Link project is entirely located within the larger Sturtevant Creek basin. Drainage for this facility must account for varying topography and varying levels of urbanization.

Project Area

The Central Bellevue (E335) segment project area is located along and adjacent to areas of protected natural resources and through highly urbanized area in order to maximize ridership. The area surrounding the Central Bellevue (E335) Segment is characterized by mix of commercial development intensities and a few residential uses. Natural resources in this area include one stream and six small wetlands. Throughout the planning process and final design, Sound Transit has made significant efforts to avoid and minimize impacts to the critical areas within and adjacent to the project area. Focused design meetings have been conducted in order to determine how design techniques can be incorporated into the Project so that impacts to critical areas are avoided and/or minimized.

Critical Areas – Existing Conditions

Methodology

To identify the presence of critical areas within the vicinity of the proposed project alignment, the applicant first gathered background information and performed a corridor walk through, then performed fieldwork based on anticipated resource locations. Background analysis and field work followed standard protocol for identification and characterization of the critical areas. Specific methodology for identification, characterization, and documentation of critical areas and anticipated impacts is presented in the project Critical Areas Report (see **Attachment E**).

Wetlands (LUC 20.25H.095)

Wetland Functions: Wetlands provide important functions and values for both the human and biological environment—these functions include flood control, water quality improvement, and nutrient production. These “functions and values” to both the environment and the citizens of Bellevue depend on their size and location within a basin, as well as their diversity and quality. While Bellevue’s wetlands provides various beneficial functions, not all wetlands perform all functions, nor do they perform all functions equally well

(Novitski et al., 1995). However, the combined effect of functional processes of wetlands within basins provides benefits to both natural and human environments. For example, wetlands provide significant stormwater control, even if they are degraded and comprise only a small percentage of area within a basin.

Existing Conditions: Ten wetland units were identified within the vicinity of the Central Bellevue (E335) segment as listed in Table 1 below. Six of these wetland units will be impacted by light rail construction. Wetland buffers were identified through application of LUC 20.25H.095.C. Buffers are listed in Table 2 below. Complete descriptions of these wetland units are included in the project Delineation Report (Attachment D) and in the project Critical Areas Report (Attachment E).

Table 1 – E335 Wetland Units

Wetland Name	Size (acres)	Drainage Basin	USFWS Classification	Hydrogeomorphic Classification Used for Rating
Lake Bellevue	7.00 ^a	Sturtevant Creek	PAB	Depressional
South Lake	0.09	Sturtevant Creek	PFO, PSS, PEM	Depressional
Central Lake	0.03	Sturtevant Creek	PSS, PEM	Depressional
North Lake	0.04	Sturtevant Creek	PFO, PEM	Slope
BNSF Southwest	0.12	West Tributary	PFO, PEM	Depressional, Slope
BNSF East	0.12 ^a	West Tributary	PEM	Depressional
BNSF West	0.83 ^a	West Tributary	PFO, PSS, PEM	Depressional, Slope
BNSF Northeast	0.02	West Tributary	PFO, PSS	Depressional
BNSF Northwest	0.06	West Tributary	PFO, PEM	Depressional, Slope
BNSF North	0.02	West Tributary	PFO, PSS	Depressional, Slope

Notes:

- a Approximate total wetland area, Includes delineated area plus estimated wetland area extending outside Project area.
- PFO = palustrine forested
- PSS = palustrine scrub-shrub
- PEM = palustrine emergent
- PAB = palustrine aquatic bed
- USFWS = U.S. Fish and Wildlife Service

Table 2 – E335 Wetland Buffers

Wetland Name	State (Ecology) and Local (Bellevue) Rating	Bellevue Buffer Widths (feet)
Lake Bellevue	III	60
South Lake	III	60
Central Lake	III	60
North Lake	IV	0
BNSF Southwest	III	60
BNSF East	III	60
BNSF West	III	60
BNSF Northeast	III	60
BNSF Northwest	IV	40
BNSF North	III	60

Note:

Ecology = Washington State Department of Ecology

2. Streams and Riparian Areas (LUC 20.25H.075)

Stream Functions: Most of the elements necessary for a healthy aquatic environment rely on processes sustained by dynamic interaction between the stream and the adjacent riparian area (Naiman et al., 1992). Riparian vegetation in floodplains and along stream banks provides a buffer to help mitigate the impacts of urbanization (Finkenbine et al., 2000 in Bolton and Shellberg, 2001). Riparian areas support healthy stream conditions.

Riparian vegetation, particularly forested riparian areas, affect water temperature by providing shade to reduce solar exposure and regulate high ambient air temperatures, slowing or preventing increases in water temperature (Brazier and Brown, 1973; Corbett and Lynch, 1985).

Upland and wetland riparian areas retain sediments, nutrients, pesticides, pathogens, and other pollutants that may be present in runoff, protecting water quality in streams (Ecology, 2001; City of Portland 2001). The roots of riparian plants also hold soil and prevent erosion and sedimentation that may affect spawning success or other behaviors, such as feeding.

Both upland and wetland riparian areas reduce the effects of flood flows. Riparian areas and wetlands reduce and desynchronize peak crests and flow rates of floods (Novitzki, 1979; Verry and Boelter, 1979 in Mitsch and Gosselink, 1993). Upland and wetland areas can infiltrate floodflows, which in turn, are released to the stream as baseflow. Stream riparian areas, or buffers, can be a significant factor in determining the quality of wildlife habitat. For example, buffers comprised of native vegetation with multi- canopy structure, snags, and down logs provide habitat for the greatest range of wildlife species (McMillan, 2000). Vegetated riparian areas also provide a source of large woody debris that helps create and maintain diverse in-stream

habitat, as well as create woody debris jams that store sediments and moderate flood velocities.

Sparsely vegetated buffers or vegetated buffers with non-native species may not perform the needed functions of stream buffers. In cases where the buffer is not well vegetated, it is necessary to either increase the buffer width or require that the standard buffer width be restored or re-vegetated (May 2003). Until the newly planted buffer is established the near term goals for buffer functions may not be attained.

Riparian areas often have shallow groundwater tables, as well as areas where groundwater and surface waters interact. Groundwater flows out of riparian wetlands, seeps, and springs to support stream baseflows. Surface water that flows in to riparian areas during floods or as direct precipitation infiltrates into groundwater in riparian areas and is stored for later discharge to the stream (Ecology, 2001; City of Portland, 2001).

Existing Conditions: One stream corridor were identified within the vicinity of the Central Bellevue (E335) segment as listed in Table 3 below. Stream buffers were identified through application of LUC 20.25H.075.C and are listed in Table 4 below. Complete descriptions of these stream corridors are included in the project Delineation Report (**Attachment D**) and in the project Critical Areas Report (**Attachment E**).

Table 3 – E335 Stream Corridors

Stream	OHWL Length ¹ (feet)	Drainage Basin ²
Sturtevant Creek	689	Sturtevant Creek

Notes:

- 1 Calculations provided by HJH for open channel areas that were delineated.
 - 2 City of Bellevue 2013b.
- OHWL = ordinary high water mark

Table 4 – E335 Stream Corridor Buffers

Stream	Local Stream Rating ¹	Buffer Width (feet)
Sturtevant Creek	Type F	50 ²

Notes:

- 1 BCC (City of Bellevue 2013a).
- 2 This stream's buffers were applied based on guidance from City of Bellevue 2013a, Chapter 20.25H.075.C.1.a.

3. Habitat for Species of Local Importance (LUC 20.25H.150)

Habitat Functions: Urbanization, the increase in human settlement density and associated intensification of land use, has a profound and lasting effect on the natural environment and wildlife habitat (McKinney 2002, Blair 2004, Marzluff 2005 Munns 2006), is a major cause of native species local extinctions (Czech et al 2000), and is likely to become the primary cause of extinctions in the coming century (Marzluff et al. 2001a). Cities are typically located along rivers, on coastlines, or near large bodies of water. The

associated floodplains and riparian systems make up a relatively small percentage of land cover in the western United States, yet they provide habitat for rich wildlife communities (Knopf et al. 1988), which in turn provide a source for urban habitat patches or reserves. Consequently, urban areas can support rich wildlife communities. In fact, species richness peaks for some groups, including songbirds, at an intermediate level of development (Blair 1999, Marzluff 2005).

Protected wild areas alone cannot be depended on to conserve wildlife species. Impacts from catastrophic events, environmental changes, and evolutionary processes (genetic drift, inbreeding, colonization) can be magnified when a taxonomic group or unit is confined to a specific area, and no one area or group of areas is likely to support the biological processes necessary to maintain biodiversity over a range of geographic scales (Shaughnessy and O'Neil 2001). As well, typological approaches to taxonomy or the use of indicators present the risk that evolutionary potential will be lost when depending on reserves for preservation (Rojas 2007). Urban habitat is a vital link in the process of wildlife conservation in the U.S.

Existing Conditions: The mosaic of vegetation communities within the project area provides habitat for a variety of terrestrial and aquatic wildlife. Wildlife relies on vegetation for food, shelter, and cover from predators. Wildlife diversity is generally related to the structure and composition of plant species within vegetative communities. In general, vegetation communities that contain few species or vegetative layers (herbaceous vegetation, shrubs, or trees) support a low diversity of wildlife, whereas vegetation communities that are more complex and contain a wide variety of plant species and vegetative layers can support a greater diversity of wildlife. Forested and riparian areas with well-developed shrub layers are likely to support the greatest number of species and populations of wildlife (Brown 1985). The majority of habitat in the project area is developed and therefore provides habitat for disturbance-tolerant species typical of urban areas.

The City recognizes 23 species of local importance (LUC 20.25H.150; City of Bellevue 2013a). As part of the analysis of species of local importance, Anchor QEA reviewed information from the WDFW PHS database on state priority species and habitats that may occur in or near the project area (WDFW 2013a). Species of local importance that could occur within the Project area were identified based on observations during the site visits, the WDFW PHS data, the presence of potential suitable habitat for priority species within the project area, and WDFW management recommendations for priority species (Larsen 1997, Larsen et. al. 2004, WDFW 2013a).

Of the 23 species considered locally important by LUC 20.25H.150, the applicant's consultant identified potential suitable habitat within the Central Bellevue (E335) Segment for 8 species. These species are listed in Table 5 below. Complete descriptions of these species and project area habitat features are included in the project Delineation Report (**Attachment D**) and

in the project Critical Areas Report (**Attachment E**).

Common Name (Scientific Name)	Suitable Habitat	Potential Suitable Habitat Present Within Project Area	State Status	Federal Status
Amphibians				
Oregon spotted frog (<i>Rana pretiosa</i>)	Ponds and lakes with dense emergent vegetation	No	Endangered	Threatened
Western toad (<i>Bufo boreas</i>)	Still water in ponds and small lakes	No	Candidate	Species of concern
Birds				
Bald eagle (<i>Haliaeetus leucocephalus</i>)	Mature trees near water and prey sources	No	Sensitive	Species of concern
Common loon (<i>Gavia immer</i>)	Marine and large lakes and rivers	No	Sensitive	None
Great blue heron (<i>Ardea herodias</i>)	Fresh and salt-water wetlands, rivers	No	Priority	Monitor
Green heron (<i>Butorides striatus</i>)	Fresh water wetlands with forested habitat	No	None	None
Merlin (<i>Falco columbarius</i>)	Prairies and conifer forests	No	Candidate	None
Osprey (<i>Pandion haliaetus</i>)	Marine coasts, lakes, and rivers	No	None	None
Peregrine falcon (<i>Falco peregrinus</i>)	Cliffs and vegetated slopes	No	Sensitive	Species of concern
Pileated woodpecker (<i>Dryocopus pileatus</i>)	Forest with snags and downed wood	Yes (mature trees)	Candidate	None
Purple martin (<i>Progne subis</i>)	Large dead trees or artificial nesting structures near wetlands, ponds, or marine systems	Yes (mature trees)	Candidate	None
Red-tailed hawk (<i>Buteo jamaicensis</i>)	Open habitat near forests	Yes (mature trees)	None	None
Vaux's swift (<i>Chaetura vauxi</i>)	Old growth forest	No	Candidate	None
Western Grebe (<i>Aechmophorus occidentalis</i>)	Large lakes	No	Candidate	None

Common Name (Scientific Name)	Suitable Habitat	Potential Suitable Habitat Present Within Project Area	State Status	Federal Status
Fish/Salmon				
Bull trout (<i>Salvelinus confluentus</i>)	Marine, rivers, and streams	No	Candidate	Threatened
Chinook salmon (<i>Oncorhynchus tshawytscha</i>)	Marine, rivers, and streams	No	Candidate	Threatened
Coho salmon (<i>Oncorhynchus kisutch</i>)	Marine, rivers, and streams	No	Candidate	Species of concern
River lamprey (<i>Lampetra ayresii</i>)	Rivers and streams	No	None	Species of concern
Mammals				
Keen's myotis (<i>Myotis keenii</i>)	Mature coniferous forest	Yes (mature trees)	Candidate	None
Long-eared myotis (<i>Myotis evotis</i>)	Mature coniferous forest	Yes (mature trees)	Monitored	None
Long-legged myotis (<i>Myotis valans</i>)	Mature coniferous forest	Yes (mature trees)	Monitored	None
Western big-eared bat (<i>Plecotus townsendii</i>)	Mature coniferous forest	Yes (mature trees)	None	None
Reptiles				
Western pond turtle (<i>Clemmys marmorata</i>)	Ponds, sloughs, small lakes	Yes (mature trees)	Endangered	Species of concern

Note:

Sources: City of Bellevue 2013, WDFW 2013, Larsen 1997, and Larsen et al. 2004.

Critical Areas – Identified Impacts

Methodology

To identify potential impacts to critical area resources associated with the Central Bellevue (E335) Segment, known resource areas were identified, characterized, and mapped. The project alignment and preliminary engineering was overlaid and contrasted with known resource areas. Where the proposed alignment and facility features were identified to overlay resource areas, engineering was adjusted and attempts to avoid impacts were made. Where impacts were unavoidable mitigation was required. This section of the staff report identifies unavoidable impacts associated with the Central Bellevue (E335) segment. A discussion outlining mitigation measures follows.

Wetland Impacts

Of the ten wetland units catalogued in the vicinity of the Central Bellevue (E335) segment, six were identified as having permanent unavoidable impacts caused to either the wetland unit or the buffer. A full discussion of impacts to wetlands, wetland buffers, wetland vegetation, and temporary impacts is included in the project Critical Areas Report (see **Attachment E**). Mitigation for permanent impacts is addressed below.

Table 5 – Wetland Impacts

Site	Drainage Sub-basin	Permanent Impact (acres)	Permanent Vegetation Conversion (acres)	Temporary Impact (acres)	Permanent Buffer Impact (acres)	Temporary Buffer Impact (acres)
South Lake	Sturtevant Creek	0.00	0.09	0.00	0.01	0.27
Central Lake	Sturtevant Creek	0.00	0.03	0.00	0.05	0.09
North Lake	Sturtevant Creek	0.00	0.00	0.04	0.00	0.00
BNSF West	West Tributary	0.00	0.00	0.00	0.09	0.00
BNSF East	West Tributary	0.05	0.08	0.00	0.14	0.01
BNSF Northeast	West Tributary	0.00	0.00	0.00	0.04	0.00
Total Wetland Impacts:		0.05	0.20	0.04	0.33	0.37

Wetland Structure Setbacks: As a linear essential public facility Sound Transit's East Link alignment is treated as transportation infrastructure right of way. Pursuant to LUC 20.25H.095.C.2.b, the East Link guideway is not considered a structure for application of LUC 20.25H and, similar to highway bridges, is therefore not required to comply with structure setback requirements.

Stream Impacts

The one stream corridor (Sturtevant Creek) was catalogued in the vicinity of the Central Bellevue (E335) segment and is anticipated to be affected by the project. Impacts will occur within the stream channel and within the stream buffer and are permanent and temporary. Impacts to the stream are outlined in Table 6 below. A full discussion of impacts to streams and stream buffers, including temporary impacts, is included in the project Critical Areas Report (see **Attachment E**). Mitigation for permanent impacts is addressed below.

Table 6 – Stream Impacts

Stream	Local Stream Rating	Permanent Impacts (sf)	Temporary Impacts (sf)	Permanent Buffer Impacts ¹ (acres)	Temporary Buffer Impacts (acres)
Sturtevant Creek	Type F	3,443	382	0.21	0.37
Total Stream Impacts:		3,443	382	0.21	0.37

Stream Structure Setbacks: As a linear essential public facility Sound Transit's East Link alignment is treated as transportation infrastructure right of way. Pursuant to LUC 20.25H.075.C.2.b, the East Link guideway is not considered a structure for application of LUC 20.25H and, similar to highway bridges, is therefore not required to comply with structure setback requirements.

Impacts to Habitat for Species of Local Importance

The primary potential construction impact on potential habitat for species of local importance (fish and wildlife habitat, wetlands, streams, and upland vegetation communities) will be removal and loss of habitat. In general, the severity of impact varies depending on the type and quantity of affected

vegetation. For example, losing plant communities that offer limited wildlife habitat, such as fragmented ornamental vegetation in commercial and residential areas, results in less of an adverse effect than losing more complex vegetation associations, such as forested areas and wetlands.

The majority of clearing and grading associated with the project will include areas with existing impervious surfaces and managed grass and fragmented and isolated tree and shrub vegetation within a densely developed urban area. The majority of the vegetation communities in the project area is landscaped and does not include understory vegetation that provides habitat for amphibian, bird, reptile, and mammal species. Wildlife species that would likely occupy habitat in these developed areas include birds and small mammals typically associated with urban residential and commercial development.

Due to the overall lack of potential habitat for species of local importance within the project area overall habitat losses resulting from the project are expected to be relatively small and are unlikely to result in a significant impact on species of local importance. A full discussion of impacts to habitat for species of local importance is included in the project Critical Areas Report (see **Attachment E**). Mitigation for permanent impacts, including habitat, is addressed below.

Cumulative Impacts

Sincere efforts have been made to avoid and minimize potential impacts to critical areas within the larger East Link Project area. These avoidance and minimization efforts have successfully eliminated any long-term impacts to geologic hazard areas, areas of special flood hazard, and species and habitats of local importance to the City of Bellevue; however, some impacts to habitat features, wetlands, and streams are anticipated.

Mitigation for potential impacts to these critical areas is proposed within the City of Bellevue in areas within or adjacent to the larger East Link project area, and not limited to the Central Bellevue (E335) segment project area. Mitigation concepts follow Sound Transit's commitment to a "no net loss" of wetland area and function and provide a surplus of functions to ensure the required mitigation ratios are met. A complete mitigation analysis is included in the project Critical Areas Report included as **Attachment E**.

Construction and operation of the East Link Project may coincide with other development projects that also affect the critical areas identified in this report. However, adverse cumulative impacts are not anticipated due to regulatory considerations, habitat enhancement efforts for natural resources in the project area, and Sound Transit's commitment to no net loss of wetland function and area.

Critical Areas – Mitigation Measures

a. Mitigation Plan

Compensatory mitigation is required for those impacts that cannot be addressed through avoidance and minimization or through the restoration of temporarily disturbed areas. In response to mitigation requirements, the applicant (Sound Transit), has developed a comprehensive mitigation plan meeting the requirements of LUC 20.25H.210. The applicant's mitigation plan is included as part of the project Critical Areas Report (see **Attachment E**).

Mitigation is primarily proposed to address identified impacts to critical areas such as wetlands, streams, and their buffers. Mitigation for wetland, stream, and buffer impacts will occur at five sites within the City of Bellevue (Sweyolocken, Mercer Slough Buffer Creation/Enhancement, Sturtevant Creek, West Tributary, and Coal Creek). All but the Coal Creek mitigation site are adjacent to the rail alignment where impacts occur. All but one of the mitigation sites are publically owned. The Mercer Slough/Bellefield site is the only one that is privately owned. Sound Transit will construct the mitigation sites concurrently with the other elements of the Project. All five mitigation sites will be protected in perpetuity through existing or new covenants/Native Growth Protection Easements or Tracts. These areas will be maintained by Sound Transit for a minimum of 5 years to ensure that the vegetation communities are established and that the mitigation goals, objectives, and performance standards are met. The protective covenants will ensure that, once established, the ecological functions of the sites are protected from future land use actions.

Mitigation for potential impacts from tree and/or vegetation removal on steep slopes affecting habitat associated with species of local importance will be addressed with additional tree plantings within the affected area, as well as within the Sweyolocken, Mercer Slough, and West Tributary mitigation sites. These three mitigation sites are also adjacent to impacted steep slope and steep slope buffers associated with habitat for species of local importance. In each instance, non-native plants will be replaced with native plants and plant diversity will be increased.

Impacts to Sturtevant Creek will be mitigated through the restoration of the channel slightly west of its current alignment. The new stream channel will match current flow and volume capacity, while providing improved habitat through native buffer plantings and improved channel substrate. The mitigation sites were selected based on their ability to replace the ecological functions that will be impacted by the Project. A complete mitigation analysis is included in the project Critical Areas Report included as **Attachment E**. City staff have reviewed the proposed mitigation plan and have concluded that the plan, as presented, meets mitigation requirements and provides a sufficient level of functional lift to offset known anticipated impacts.

Critical Areas – Conclusion

The applicant has provided documentation necessary to demonstrate compliance with the requirements of the City of Bellevue Critical Areas Overlay District. Staff have reviewed documentation provided by the applicant and have determined the proposed Central Bellevue (E335) segment, including mitigation measures proposed throughout the East Link project, is in compliance with the City of Bellevue Critical Areas requirements. **See Section XI for related condition of approval.**

Use of City Right-of-Way

No at-grade RLRT facility or system shall be permitted in the City of Bellevue rights-of-way without prior City approval.

Finding: The applicant is required to apply for and receive an approval of a Right of Way Use Permit from the City of Bellevue prior to work or hauling in the Right of Way. **See related condition of approval in Section XI.**

20.25M.050 Design Guidelines

A. Design Intent

LUC 20.25M.030.B and C require City permit approvals to be consistent with the Comprehensive Plan including Light Rail Best Practices which emphasizes the need for context sensitivity in design. Subsection B of this section is intended to provide guidance to any CAC formed pursuant to LUC 20.25M.035.B regarding the existing and planned contexts within which RLRT systems or facilities are proposed. The information contained in this subsection is intended to provide a framework for the CAC's work, and to help the CAC determine whether a context sensitive outcome has been achieved through the incorporation of location-appropriate design features in required light rail permits. A discussion of context and design considerations for the three affected subareas is included in Section II of this staff report.

Finding: As discussed in Section I of this staff report, the design intent for light rail in this segment responds to three separate subareas. As designed and conditioned, the three stations in this segment will reflect the character of Bellevue as a regional destination as well as provide gateway opportunities to points east and west. Each station has been designed to reflect the context characteristics of the vicinity. Art enhancements, unique materials, and pedestrian amenities support design intent goals throughout the East Link alignment in the City of Bellevue.

Additional General Design Guidelines

- The CAC recommends that variable seating heights be provided at all light rail stations in Bellevue.

Finding: See Section XI for a condition of approval related to variable heights and ADA compliance.

- The CAC recommends that a decorative gate be used for access to the electrical building near the tunnel portal and East Main Station.

Finding: Sound Transit has hired an artist to design the decorative panels for the gate to the electrical building service yard. The panels will be installed by the contractor.

- The CAC recommends that the design of the Bellevue Downtown Station should complement the existing City Hall and new plaza design while providing distinct elements that differentiate the two uses.

Finding: The use of terra-cotta cladding and the proposed umbrella canopy at the Bellevue Downtown Station is consistent with this advice.

- The CAC recommends the city work with Sound Transit to seek out opportunities for additional weather protection complementary to the plans for landscaping, art, and visual access at the Bellevue Downtown Station.

Finding: The currently proposed umbrella canopy currently proposed for the western side of the plaza at the Bellevue Downtown Station provides weather protection beyond what is typically found at other surface light rail stations in the Link system.

- The CAC recommends that Sound Transit include places for people to rest along the walkway connecting the Wilburton (Hospital) Station to 116th Ave NE.

Finding: Sound Transit has provided updated drawings that include two benches along the walkway.

- The CAC recommends that Sound Transit use a stacked stone or brick type pattern with variegated earth tones for noise walls south of the tunnel portal to provide continuity with the walls recommended in the adjoining South Bellevue Segment. Ashlar stone walls are one recommendation from the CAC.

Finding: See Section XI for a condition of approval related to noise wall design.

- The CAC recommends a special treatment that may include art or vegetation for the surface structure at the mid tunnel access point.

Finding: Working with the Bellevue Parks Department at the beginning of final design, it is the City's intent to redesign the pocket parks, including this location, after completion of light rail construction. Sound Transit was directed to only reseed disturbed areas and not add planting due to the City intended upgrade of this area. Sound Transit is providing a special treatment for the surface structure by including artist selected designed tiles for the curved wall of the structure facing the street.

Finding: Sound Transit evaluated alternate locations for the signal house and maintenance access road proposed near the Lake Bellevue Condominiums in August and September of 2015 and determined that the proximity to the track switches coupled with existing access made the proposed location near Lake Bellevue ideal. Sound Transit evaluated potential locations on the west side of the tracks but determined that the location was not feasible due to both the steep grade and the rail bank requirements under which ST cannot preclude the possibility of future freight mobility use in the corridor. Lastly, Sound Transit cannot site the signal bungalow and associated systems within an envelope in which future need would require ST to relocate it.

- The CAC recommends that the city insure that Sound Transit adhere to all applicable water quality and storm drainage requirements.
- The CAC recommends that the City of Bellevue insure that Sound Transit evaluate and consider local soil conditions in station design and engineering.
- The CAC recommends that the City of Bellevue insure that Sound Transit considered all local environmental factors in their noise analysis, including, but not limited to the transmission of sound across Lake Bellevue, elevated structures on piles, and noise measurement locations.

Finding: Sound Transit is required to satisfy all local, state, and federal requirements for storm drainage, geologic conditions, and noise. A third party analysis of the noise report submitted in support of this permit was conducted by a qualified acoustician who found the report adequately identified and mitigates for anticipated noise impacts of operations.

- The CAC recommends that Sound Transit provide an interpretive sign regarding Sturtevant Creek at the bridge to the pedestrian walkway.

Finding: Sound Transit intends to provide an interpretive sign regarding Sturtevant Creek at the bridge crossing. This sign will be included in the separate signage contract scheduled for implementation upon completion of station construction contracts.

- The CAC recommends a special artistic or architectural treatment for the elevated guideway crossing of NE 8th Street due to its prominence.

Finding: Sound Transit has invested significant time and attention to the design of the guideway and support columns to provide special architectural treatment. The columns and support “heads” include special shaping and facets to reduce the visual size while creating shadow lines and a varied appearance as time and lighting conditions change. Instead of using standard precast “T’s” the guideway structure utilizes “tub” shapes and is sized and includes tapering of the “tub” walls to provide a sleek appearance.

- The CAC recommends the use of concrete masonry units (CMU) for both the east and west faces of the Wilburton (Hospital) Station.

Finding: Sound Transit has included the CMU veneer for the west wall in their 100% review documents.

- The CAC recommends that the station area planning team or downtown livability team evaluate access to and from the Bellevue Downtown Station by pedestrians and bicyclists.

Finding: The Downtown Livability Team has evaluated pedestrian improvements throughout the downtown area and has made recommendations regarding revised sidewalk widths, landscaping, and wayfinding. Many of these recommendations were provided by the Downtown Livability CAC.

- The CAC recommends that restroom facilities be incorporated into the Bellevue Downtown Station design.
- The CAC recommends that both audio and visual cues be included in station design.
- The CAC recommends a signature treatment for the railing for the entire span from the Bellevue Downtown Station to the Wilburton (Hospital) Station. The CAC recommends Sound Transit continue to use the style of rail planned for the I-405 crossing to achieve this goal.
- The CAC strongly recommends that Sound Transit further evaluate alternative locations for the signal house and maintenance access located in close proximity to the Lake Bellevue Condominiums.

Restrooms at Bellevue Downtown Station

Per Sound Transit Board Motion No. M98-67 adopted on September 10th, 1998, Sound Transit shall provide public restrooms at when all or most of the following criteria are met:

- 1. Where they have the greatest security, staffing is present, effective maintenance can be provided, and costs are shared with all agencies using that facility.*
- 2. Where staffing is already provided for activities such as concessions, customer service, service supervision, or security.*

3. *Where concessions are in place and concession revenue covers ongoing operating and maintenance expense for public restrooms.*
4. *Where capital costs are not excessive and prohibitive to construct these facilities.*

All criteria stated above have not been met to provide public restrooms at the Bellevue Downtown Station.

More recently, Sound Transit did include public restrooms into the design of the South 200th Station in the City of SeaTac however; the restrooms will be operated and maintained using funds from leases of retail space as part of the parking/retail structure supporting the station.

Railing

Sound Transit has not extended the WSDOT I-405 Signature Railing design beyond the extents of the I-405 Corridor. This signature railing design, is a component identified in the WSDOT "Interstate 405 Urban Design Criteria" (UDC) manual. The WSDOT design intent is to "produce an attractive and unified highway system that will enhance corridor continuity and help guide traffic safely through the I-405 corridor... The design criteria is necessary to produce an intended aesthetic form, function, and appearance of the corridor for each highway feature and element in order to provide predictability and coherence in the visual environment throughout the I-405 corridor project." The "hoop" railing noted in the UDC is intended for pedestrian sidewalk crossings of I-405. ST has included the "hoop" railing design for the guideway span since the guideway did not have solid concrete barriers matching non-pedestrian highway crossing criteria. Continuing the "hoop" railing design beyond the I-405 Corridor extents would dilute the intended benefits of the I-405 design criteria. In addition, acoustic panels on the east side of the I-405 crossing will interrupt the continuity of the railing. The provided railing design beyond the I-405 crossing is a visually minimalist design intended to disappear from view and not call attention to the railing.

Departures by the Director from specific recommendations included within the CAC's Advisory Document shall be limited to those instances where the Director determines that the departure is necessary to ensure that the RLRT facility or system is consistent with: (i) applicable policy and regulatory guidance contained in LUC 20.25M.035.E which states that advice provided by the CAC shall be objectively based upon the policies, regulations, guidelines and other documents adopted for the RLRT system and facility to ensure that the final project is designed to achieve a context sensitive outcome.; (ii) authority granted to the CAC pursuant to this section; (iii) SEPA conditions or other regulatory requirements applicable to the RLRT system or facility; or (iv) state or federal law. Departures from the CAC Advisory Document shall be addressed in the recommendation or decision by the Director and rationale for the departures shall be provided.

Visual Cues

The CAC made a recommendation that the stations in the Central Bellevue Segment should have both audio and visual cues at the station. The segment of East Link within the City of Bellevue constitutes six miles of a much larger regional system. Sound Transit provides audio cues at all of its stations but has not provided visual cues elsewhere in the system. The director has determined that the safety cues should be consistent with the remainder of the regional system and requiring Sound Transit to provide another system only within Bellevue is not practicable or feasible.

Signal House

Sound Transit evaluated alternate locations for the signal house and maintenance access road proposed near the Lake Bellevue Condominiums in August and September of 2015 and determined that the proximity to the track switches coupled with existing access made the proposed location near Lake Bellevue ideal. Sound Transit evaluated potential locations on the west side of the tracks but determined that the location was not feasible due to both the steep grade and the rail bank requirements under which Sound Transit cannot preclude the possibility of future freight mobility use in the corridor. Lastly, Sound Transit cannot site the signal bungalow and associated systems within an envelope in which future need would require Sound Transit to relocate it.

V. PUBLIC NOTICE AND COMMENT

Application Date: January 5, 2015

Application Completeness Date: February 5, 2015

Notice of Application published: February 26, 2015

Public Notice Signs installed: February 26, 2015

Minimum Comment Period ended: March 12, 2015

Although the minimum required public comment period ended on March 12, 2015, comments were accepted up to the date of this decision. This permit application was discussed with the public and CAC at numerous CAC meetings and open houses. Staff received several written and numerous comments regarding the Central Bellevue Segment during CAC review. Those comments are summarized below.

Noise

A few commenters expressed some concern regarding noise from train operations and construction and the negative impacts that might have on residential properties in the vicinity. At least one commenter expressed concern regarding noise and vibration impacts to the Meydenbauer Center.

Finding: A detailed discussion regarding noise is located in Section VII of this report. There are numerous conditions of approval in Section XI regarding noise including, but not limited to, noise wall construction and timing, train maintenance,

and monitoring and contingency. Although vibration is not addressed in City of Bellevue codes, Sound Transit's consultant has shown that predicted vibration levels are within required FTA standards.

Tree Removal and Replacement

There was some concern expressed regarding the amount of tree removal and lack of tree replacement as mitigation. There was also concern that any tree replacement cannot mitigate the loss of mature existing trees.

Finding: A summary of tree removal and tree replacement is located in Section IV of this staff report. Although it is necessary to remove a significant amount of trees in the Central Bellevue Segment to facilitate light rail construction, there will be a significant amount of replacement trees as mitigation. Working collaboratively with staff, Sound Transit has reduced the number of trees for removal from what was originally anticipated. These will be a mixture of evergreen and deciduous trees that will include seasonal color.

Traffic Impacts During Construction

At least one commenter commented that access to the Meydenbauer Center should be maintained and specifically during planned events.

Finding: Staff acknowledges that there will be unavoidable impacts due to construction activities related to light rail. The city and Sound Transit will continue to work together to minimize these impacts as the project moves towards construction. Any lane closures or traffic control will be reviewed as part of required Right of Way Use Permit review. Although construction related parking and traffic was not within the scope of CAC review, they have noted their comments within their advice to the Director.

North Façade of the Bellevue Downtown Station

One commenter noted that the aesthetics and design treatments for the north façade of the Bellevue Downtown Station should be of a high quality and relate to the Meydenbauer Center to the north.

Finding: The design of the north façade is augmented by two tiers of landscaping and visual access to the art treatment and activities through the large glass wall on NE 6th Street.

VI. TECHNICAL REVIEW

A. Clearing & Grading

The Clear and Grade Reviewer reviewed the plans and materials submitted for this project and determined that clearing and grading portion of this Design and Mitigation Permit application can be approved. The future Clearing and Grading Permit application for this development must comply with City of Bellevue Clearing and Grading Code. (BCC 23.76)

B. Utilities

The Utilities Department approval of this Design and Mitigation Permit is based on the conceptual design only. Refer to Conditions of Approval regarding utilities in Section XI of this report.

C. Transportation

Project Area

This staff report covers segment E335 of the East Link light rail line in the City of Bellevue, starting from East Main Station at 112th Avenue SE/ SE 4th Street and extending to NE 6th Street Station at 116th Avenue NE/NE 6th Street, Hospital Station at 118th Avenue NE/NE 8th Street and encompassing the most westerly street frontage of 120th Station at 120th Avenue NE/ NE Spring Boulevard. This review focuses on the transit guideway, in the central portion of Bellevue from 112th Avenue SE/ SE 4th Street to 120th Avenue NE.

Access

Public access to the proposed project will be provided via light rail stations located on 112th Avenue SE/ SE 4th Street, 116th Avenue NE/NE 6th Street, 118th Avenue NE/NE 8th Street and 120th Avenue NE/ NE Spring Boulevard. Pedestrians will be able to enter or exit the light rail station at each end when boarding or alighting from an East Link train.

Some adjacent properties will have their vehicular access revised as part of the street revisions associated with construction of the light rail line. Some driveways will be reconstructed, realigned, or closed. Access from SE 4th Street to 112th Avenue SE will be restricted to emergency vehicles only, and access to Surry Downs Park will be served through the neighborhood. Access modifications will be addressed in the construction permits for the various roadway revisions associated with the light rail line.

Street Infrastructure Improvements

Generally, the design of street infrastructure improvements associated with a development must conform to the requirements of the Americans with Disabilities Act, the Transportation Development Code (BCC 14.60), the Transportation Department Design Manual, and any requirements stated in a City of Bellevue Staff Report. However, for East Link, formal agreements between the City and Sound Transit have already established some unique procedures and requirements. Prior to review and approval of this permit application (LD 15-102719), design plans for East Link segment E335 went through multiple rounds of review and comment by City staff, with responses from Sound Transit staff and consultants. Comments regarding design details have been made and evaluated, and the plans have been revised as appropriate.

Construction plans for East Link must generally comply with City standards regarding features such as curbs, sidewalks, bike lanes, street widening or realignment, driveway approaches, streetlights, signals, street trees, sight

triangles, grades, turning geometry, and undergrounding of overhead wires. However, the City has already reviewed and agreed to accept specific variations from City standards during the aforementioned review and comment process. For some significant variations from City standards, especially for variations from ADA standards, the City will document its acceptance through a formal process known as Deviations, Exceptions, and Maximum Extent Feasible (MEF), with input from Sound Transit's design team as needed. Use of the Deviations, Exceptions, and MEF process will be at the City's discretion. Minor variations will not require that process. Such issues outside the guideway and station will be dealt with in the construction permits for the various roadway revisions associated with the light rail line.

Specific variations from City standards include the following:

1. Driveway approaches: The project may require revisions to existing driveways. In some locations, City standards for driveway width, grade, geometry, or other aspects cannot be met without impacts on adjacent property or adjacent utilities. In these situations, Sound Transit's design team has attempted to meet the needs for driveway functionality as much as feasible while minimizing deviations from City standards.
2. The Americans with Disabilities Act (ADA): City standards require compliance with ADA for all sidewalks, sidewalk ramps, and crosswalks. This includes meeting specific requirements for cross slope, longitudinal slope, and changes in level for all public sidewalks. However, the natural lay of the land sometimes makes it infeasible to meet all ADA requirements at a reasonable cost within the space available. At the City's discretion, the Deviation, Exception, and Maximum Extent Feasible process may be used when ADA standards cannot be met. Due to the length of time between plan review and completion of construction, some ADA standards may change. If so, Sound Transit must make a reasonable effort to comply with the latest ADA standards at the time of construction.
3. Fixed Objects: City standards state that no fixed objects, including fire hydrants, trees, and streetlight poles, are allowed within 10 feet of a driveway edge, defined as Point A in standard drawings DEV-7A, 7D, 7E, or 7F. Fixed objects are defined as anything with breakaway characteristics stronger than a 4-inch by 4-inch wooden post. During previous review cycles, some locations were identified where the City agreed to accept a streetlight pole or other fixed object located at less than 10 feet from Point A at a driveway edge in order to avoid other conflicts.
4. Tree and Streetlight Separation: Generally, street trees and street lights must be at least 25 feet apart. However, in some locations, less separation may have been approved during previous review cycles.
5. Other: Throughout the review and construction processes, other variations from City standards may be identified. The Deviation, Exception, and

Maximum Extent Feasible process will be followed when determined necessary by the City.

Easements

Sidewalk and utility easements shall be granted to the City as needed to encompass the full width of any City sidewalks located outside the City right of way on streets affected by this project. Easements encompassing the location of traffic signal and streetlight facilities may also be required if located outside right of way or sidewalk easements. Easements encompassing retaining walls behind sidewalks may be required where retaining walls are necessary to support a City sidewalk or street. Existing utility easements affected by this project shall be identified, and negative impacts on such easements shall be mitigated or easements relinquished. The granting of easements to the City shall utilize forms and procedures acceptable to the City.

Right of Way Dedication

New right of way shall be dedicated to the City to the back of any new or existing curb line along any City street where the new or existing curb will not be within existing City right of way. Dedication of new right of way to the City shall utilize forms and procedures acceptable to the City.

Holiday Construction and Traffic Restrictions

From November 15th to January 5th, construction activities such as hauling and lane closures may be restricted during certain hours in some areas due to holiday traffic. The dates, times, and locations of these restrictions, if any, will be conditioned in the Right-of-Way Permit(s) to be obtained by contractors.

Use of the Right of Way During Construction

Applicants or contractors often request use of the right of way and of pedestrian easements for materials storage, construction trailers, hauling routes, fencing, barricades, loading and unloading and other temporary uses as well as for construction of utilities and street improvements. A Right of Way Use Permit for such activities must be acquired prior to issuance of any construction permit including any demolition permit. Sidewalks may not be closed except as specifically allowed by a Right of Way Use Permit.

Pavement Restoration

The City of Bellevue has established the Trench Restoration Program to provide developers with guidance as to the extent of resurfacing required when a street has been damaged by trenching or other activities. Under the Trench Restoration Program, every street in the City of Bellevue has been examined and placed in one of three categories based on the street's condition and the period of time since it has last been resurfaced. These three categories are, "No Street Cuts Permitted," "Overlay Required," and "Standard Trench Restoration." Each category has different trench restoration requirements associated with it. Damage to the street can be

mitigated by placing an asphalt overlay well beyond the limits of the trench walls to produce a more durable surface without the unsightly piecemeal look that often comes with small strip patching. The pavement restoration requirements for any street segment may change over time as the condition of the pavement changes. Before doing any construction work in a street, the developer or contractor will be required to obtain a Right of Way Use Permit, which will specify the trench and pavement restoration requirements for street segments likely to be affected.

Transportation Impact Fees

The City of Bellevue charges transportation impact fees for developments that generate at least one new PM peak hour trip. However, under Bellevue City Code 22.16.070.B.3, "public transportation facilities" are exempt from payment of City of Bellevue transportation impact fees. Furthermore, Bellevue City Code 22.16.020.C says that "Development does not include buildings or structures constructed by a regional transit authority." Therefore, transportation impact fees will not be required for any buildings or structures constructed by Sound Transit for the East Link light rail line.

Traffic Standards Code

Bellevue's Traffic Standards Code (BCC 14.10) requires that development proposals generating 30 or more new p.m. peak hour trips undergo a traffic impact analysis to determine if the concurrency requirements of the state Growth Management Act are maintained. This application is exempt from the requirements of the TSC per BCC 14.10.020.I (2) which identifies public transportation facilities as exempt from the requirements of that chapter. See Section XI for transportation related conditions of approval.

D. Fire

The Fire Reviewer reviewed the plans and materials submitted for this project and determined that the fire-related portion of this Design and Mitigation Permit application can be approved.

VII. STATE ENVIRONMENTAL POLICY ACT (SEPA)

Sound Transit, the Washington State Department of Transportation and the Federal Transit Administration jointly conducted environmental review of the East Link Project. A Draft Environmental Impact Statement (Draft EIS) was prepared and issued on December 12, 2008. A Supplemental Draft Environmental Impact Statement (SDEIS) was prepared to supplement the 2008 Draft EIS and address new information, new alternatives, and design modifications for the East Link project. The SDEIS was issued on November 11, 2010. The Final EIS identifying the preferred East Link alignment was issued for the East Link RLRT project on July 15, 2011. Following issuance of the FEIS a SEPA addendum was issued on March 26, 2013. These documents are collectively referred to as the "East Link FEIS."

The East Link FEIS and supporting documentation fulfill State Environmental Policy

Act requirements for the Central Bellevue Segment and are incorporated by this reference under the terms of BCC 22.02.037 and WAC 197-11-600. Technical information was submitted by Sound Transit with the Central Bellevue Segment application and other additional information was required by the environmental coordinator. The following additional information to the environmental documents are required by the City of Bellevue under its substantive SEPA authority to condition proposals pursuant to RCW 43.21C.060, WAC 197-11-660 and BCC 22.02.140 and the limitations and requirements contained therein. The East Link FEIS together with the supporting documentation are available for review in the City of Bellevue Records Room, Lobby Floor, Bellevue City Hall, 450 110th Ave NE.

NOISE

Predicted noise impacts in the Central Bellevue segment were evaluated by Sound Transit during environmental review of the East Link project, and with additional specificity as a component of this Design and Mitigation Permit review process. Noise impacts fell into two broad categories that included light rail vehicle operation noise and project construction noise. Operational noise was further categorized into specific noise sources that included train operations and stationary noise sources.

During review of the Central Bellevue segment application, staff reviewed the East Link FEIS documents prepared by Sound Transit including predicted noise levels for the RLRT system and facility. Staff also reviewed the noise analysis prepared on behalf of Sound Transit and submitted with the Central Bellevue segment application that updated the information that was contained in the East Link FEIS, noise analysis prepared for the first Design and Mitigation Permit application that was issued for the Bel Red (E340) segment. Studies reviewed for the preparation of this staff report are available in the project file and include:

- ATS Consulting, December 22, 2014, "Contract E335 Noise, Vibration and Groundborne Noise Report".
- ATS Consulting, January 30, 2015, "City of Bellevue Noise Impact Assessment, East Link LRT Project E320 and E335 Contracts-Mitigation to Meet Nighttime Ambient."
- ATS Consulting, February 23, 2015, "City of Bellevue Noise Impact Assessment, East Link LRT Project E320 and E335 Contracts-Mitigation to Meet Nighttime Ambient-Revision #2."
- East Link Bel Red Segment Design and Mitigation approval (and supporting noise analysis), April 23, 2015.
- Greenbusch Group, November 25, 2015 "East Link Light Rail Project – South Bellevue to Overlake Transit Center, Contract 320 – South Bellevue to E. Main Station".

The above-listed information was provided to Julie Wiebusch for peer review on behalf of the City of Bellevue. Ms. Wiebusch is a principal and acoustician with the Greenbusch Group, who has been hired to assist the City with its technical review of noise related issues arising in the context of the Sound Transit permit review process. The results of Ms. Wiebusch's expert technical review are contained in the East Link Light Rail Project-South Bellevue to Overlake Transit Center Contract

E335. Main Station to Station EB635+00 Noise, Vibration and Groundborne Noise Report – Peer Review dated April 11, 2016. A copy of this peer review document is available for review in the project file.

Noise generators associated with future operation of the East Link project through Central Bellevue were described in the following categories: train operations (wheel/rail interface noise, train-mounted warning devices, track crossovers and wheel squeal) and stationary noise sources (station public address systems, audible warnings for at-grade crossings, electrical transformers and traction power substations). Based on review of the studies listed above, the Bellevue Noise Control Code applies to operational noise, stationary noise and construction noise anticipated for the Central Bellevue Segment (E335) as described below.

TRAIN OPERATIONS

Train operations are expected to generate noise associated with operation of a light rail train from rail-wheel contact, wheel squeal and train mounted warning devices.

Vehicle Wheel/Rail Noise

The peer review contained in the project file evaluates predicted train operation noise against Bellevue City Code (BCC) limits on noise. The primary noise generator from operating light rail vehicles is the noise from the wheel/rail interface. Gaps in the trackwork at crossovers and switches can also create noise when a train passes over them. Trains have electric motors and other equipment, but these do not contribute substantially to noise from passing trains. When expected noise is considered together with the legal limitations on City authority to apply conditions that unreasonably burden a development project, the City has concluded that a light rail motor vehicle maintained and operated in good working condition should be required to meet existing ambient noise levels when the rail operation occurs in a Class A (residential) EDNA (Environmental Designation for Noise Abatement). The rationale for this conclusion is provided below.

A small portion of the Central Bellevue E335 Segment passes through a Class A (residential) EDNA in the vicinity of the East Main Station and South Portal. Under the Bellevue Noise Control Code (Chapter 9.18 BCC), the maximum permissible noise level in this area is 55 dBA during the daytime hours and 45 dBA between 10:00 PM and 7:00 AM. BCC 9.18.030(B). However, noise from train operations in a Class A EDNA is exempt from the maximum noise limits in the Noise Control Code between the hours of 7:00 a.m. and 10:00 p.m. BCC 9.18.020.B.5.

Within the E335 Segment, the existing ambient noise levels during nighttime hours are in excess of the Code limits and currently range between the low 50s dBA and the high 60s dBA (measured in one-hour Leq). See Memorandum dated February 23, 2015 from Steven Wolf of ATS Consulting. This is due largely to traffic sounds from I-90, I-405, and local traffic along 112th Avenue SE.

To mitigate the impacts of its proposal, Sound Transit proposes to construct a six foot noise wall on the west side of its tracks near the East Main Station and South

Portal that will reduce noise from train operations to ambient noise levels or lower at all properties in a Class A EDNA in the Central Bellevue segment. This noise wall, including its length and height, is depicted in the mitigation map that is Exhibit O to the Amended and Restated Umbrella Memorandum of Understanding between the City and Sound Transit dated May 6, 2015, and were included in the Central Bellevue 60% design drawings.

There are two other noise walls in the Central Bellevue Segment. There are 3 foot acoustic panels on the north side of the guideway in an area east of I-405, and a 6 foot noise wall north of the Wilburton Station on the east side of the guideway. These walls are in the Class B EDNA.

The facts and circumstances created by the presence of the light rail system in the Central Bellevue Segment are unique, and not anticipated in the City's Noise Control Code. In light of these unique facts and circumstances, the Department determines and concludes, pursuant to its authority under the State Environmental Policy Act (SEPA), that it is not reasonable or appropriate to require Sound Transit to construct additional noise walls to bring noise from train operations below ambient noise levels.

The City's Environmental Procedures Code directs the Department to use its substantive SEPA authority when there are "[u]nusual circumstances related to a site or to a proposal," BCC 22.02.140.C, which is the case here. SEPA's policies and procedures are "supplementary" to all City regulations, per RCW 43.21C.060:

The policies and goals set forth in this chapter are supplementary to those set forth in existing authorizations of all branches of government of this state, including state agencies, municipal and public corporations, and counties.

The City's Comprehensive Plan is one of the City's substantive SEPA policies per BCC 22.02.140.B.1 of the City's Environmental Procedures Code, and the City's Comprehensive Plan is the City's "foundational policy document" (Introduction & Vision page 1). Environmental Policy 95 anticipates the unique situation created by the presence of a light rail system along Bellevue Way and 112th Avenue (emphasis added):

EN-95. Require a noise analysis for transportation projects in or near residential areas if existing or projected noise levels exceed city-adopted standards, and **implement reasonable and effective noise mitigation measures when appropriate.**

Mitigation for light rail vehicle operation noise in excess of the noise walls proposed by Sound Transit and the other mitigation set forth below, would not result in any discernible benefit to persons on the receiving properties and therefore would not be reasonable or appropriate.

In order to ensure that noise levels are maintained at or below the ambient levels in the Class A EDNA and meet city code requirements in the Class B EDNA during operations, the applicant will be required to maintain light rail vehicles in a well-operating manner. To ensure the light rail vehicles are maintained over time, an Operations and Maintenance Program is required to meet FTA and City prescribed noise levels. At a minimum, this program must include rail grinding and replacement of worn rails including cross over switches, vehicle wheel truing and replacement, vehicle maintenance and operator training. In addition, all light rail vehicles must be designed with wheel skirts to reduce noise from the rail-wheel interface. This condition is reasonable and necessary to ensure that operations are maintained consistent with impacts predicted in the East Link FEIS and subsequent noise analysis, and supported by evidence and the opinions of the City's technical expert Julie Wiebusch and the Greenbusch Group. Refer to Condition of Approval contained in Section XI of this staff report.

The requirements imposed in the conditions of approval to mitigate for noise generated by proposed light rail vehicle operation, and monitoring of performance once the trains are operational, will ensure that noise generated from light rail vehicle operation will be consistent with ambient noise levels existing at the time this approval was granted. These conditions are reasonable and necessary to ensure that operations are maintained consistent with impacts predicted in the East Link FEIS and supported by evidence and the opinions of the City's technical expert Julie Wiebusch and the Greenbusch Group. Refer to Condition of Approval contained in Section XI of this staff report.

Wheel Squeal Noise

Noise generation related to wheel squeal on tight radius curves falls outside the scope of what would typically be expected from a well-operating light rail vehicle or system, and could compromise the long term compliance with ambient noise levels existing at the time of City review. Wheel squeal was reported in the Final EIS documents to occur predominantly along curved track segments with a radius of less than 600 feet. In the Central Bellevue segment, the curve north of the East Main Station, the curve west of the Downtown Bellevue Station, and the curve between the I-405 alignment and 116th Ave NE have a design radius of less than 600 feet. In order to mitigate for noise generation expected to occur on curved track segments, a lubrication system is required on all curves with a radius of 600-feet or less. For curves with a radius between 600 to 1,250 feet, the project must be designed to accommodate a lubrication system if wheel squeal is detected during noise monitoring required to be undertaken during system testing and for a period of two years after fare operations begin. This condition is reasonable, necessary to ensure that operations are maintained consistent with impacts predicted in the East Link FEIS, and supported by evidence and the opinions of the City's technical expert Julie Wiebusch and the Greenbusch Group. Refer to Condition of Approval contained in Section XI of this staff report.

Train-Mounted Warning Devices

Train-mounted warning devices are exempt from application of the Noise Control Code pursuant to BCC 9.18.020.A.10 because they are classified as protective warning devices in the applicable excerpted section of the code provided below.

9.18.020 Exemptions.

A. The following sounds are exempt from the provisions of this chapter:

.....

10. Sounds created by safety and protective warning devices where noise suppression would render the device ineffective;

As a result of the Collaborative Design Process, there are no at-grade street crossings in E335 although there are two pedestrian crossings at the East Main Station. Because the pedestrian crossings are at the station, no bells and horns will emanate from light rail vehicles along the E335 segment except when entering and leaving Stations or if necessary for emergency purposes.

Where required, trains will operate with a high bell, low bell and horn. The horn is only used for emergency situations that are infrequent and unpredictable. The train-mounted bell is proposed to be used for arrivals and departures at a station. Train-mounted bells should operate at a sound level that is the minimum necessary for the warning device to be effective. The applicant is proposing to use the high bell with a sound pressure level of 80dBA at 50 feet during the daytime hours from 6 a.m. to 10 p.m. The low bell will have a sound pressure level of 72 dBA at 50 feet and is proposed for use during nighttime hours from 10 p.m. to 6 a.m. In order to minimize the intrusion of the warning sound onto adjacent properties, the applicant will be required to provide operator training on bell and horn operation protocols. In addition, the train-mounted warning devices will be required to direct sound forward of the vehicle in its direction of travel. This condition is reasonable, necessary to ensure that operations are maintained consistent with the Bellevue Noise Control Code, and supported by evidence and the opinions of the City's technical expert Julie Wiebusch and the Greenbusch Group. Refer to Condition of Approval contained in Section XI of this staff report.

STATIONARY NOISE SOURCES

Noise generated from stationary sources proposed as a component of the Central Bellevue segment includes three electrical transformers, two traction power substations, condensing units, emergency ventilation fan operation, and the public address (PA) system at stations,

Bellevue City Code includes maximum permissible noise levels applicable to stationary noise sources proposed for the Central Bellevue segment. Per BCC 9.18.030 receiving properties located within the Class A EDNA (East Main Station,

South Portal) found in Central Bellevue, noise sources are limited to 55 dBA during daytime hours and 45 dBA from 10:00 p.m. to 7:00 a.m. For receiving properties located within the Class B EDNA noise sources are limited to 60 dBA (Bellevue Downtown Station).

Electrical Transformers

A 75 kVA transformer is proposed for each station. The distance to the nearest receiving properties range between 30 and 40 feet. Manufacturer's sound level data of a transformer between 51 kVA and 150 kVA is less than 50 dBA at 3 feet. The predicted noise level at each station is below the Bellevue Noise Code Limit. The noise level at the nearest receiving property is predicted using the following equation:

$$Leq(1hr) = Leq_{ref} - 20 \cdot \log(dist/3)$$

where Leq_{ref} is the reference noise level of 50 dBA at 3 feet and $dist$ is the distance from the transformer to the property line of the receiving property.

Note that this prediction methodology assumes the transformers operate continuously. Noise from the transformers would also be diminished at the property line as the distance from the transformer increases. The transformers are expected to comply with the terms of the Noise Control Code once operational. In order to ensure compliance with predicted sound levels, the applicant will be required to install the transformers consistent with manufacturer specifications. Monitoring of the stationary noise will be required to commence upon the initiation of system testing. Additional noise baffling may be required by the DSD director if maximum permissive noise levels are exceeded at receiving properties when the stationary noise source is placed into operation. This condition is reasonable, necessary to ensure that operations are maintained consistent with the Bellevue Noise Control Code, and is supported by evidence and the opinions of the City's technical expert Julie Wiebusch and the Greenbusch Group. Refer to Condition of Approval contained in Section XI of this staff report.

Traction Power Substations

There are two TPSS units within the E335 contract. One is located near the South Tunnel Portal and the other adjacent to the storage track. The unit near the South Tunnel Portal is located on land that is zoned residential and the receiving property is also residential. The City of Bellevue Noise Code allow a nighttime noise level of 45 dBA at the South Tunnel Portal location. The TPSS unit located near the storage tract has a commercial receiving property and the maximum allowed nighttime noise level of 60 dBA. The predicted noise levels for each location is below the allowable City of Bellevue code limits.

Public Address System

The PA systems are an anticipated source of noise associated with the Central

Bellevue Segment. Each of the three stations in the Central Bellevue Segment will have a PA system. The predicted sound levels are based on speakers set at 10 dBA above ambient. The predicted sound levels at the Bellevue Downtown Station and Wilburton Station are in compliance with the City of Bellevue Noise Code. Sound levels at the East Main Station are in excess of the nighttime code limit of 45 dBA for Class A EDNA, however, the six foot sound wall west of the station reduces the noise level to within code limits.

In an enclosed environment such as a transit station sound can continue to reflect for a period of time after a source has stopped emitting sound. This prolongation of the sound is called reverberation. Reverberation time (TR60) is defined as the time required, in seconds, for the average sound in a room to decrease by 60 decibels after a source stops generating sound. Reverberation time is the primary descriptor of an acoustic environment.

Reverberation time is affected by the size of the space and the amount of reflective or absorptive surfaces within the space. A space with highly absorptive surfaces will absorb the sound and stop it from reflecting back into the space. This would yield a space with a short reverberation time. In general, larger spaces have longer reverberation times than smaller spaces. Therefore, a large space will require more absorption to achieve the same reverberation time as a smaller space.

Reverberation time for the transit stations are calculated using the Sabin Formula:

$$RT_{60} = 0.049 \cdot V/a$$

where V is the volume of the space (ft³) and a is the total room absorption at a given frequency in sabins. It is important to note that the absorption and surface area must be considered for every material within a space in order to calculate sabins. The number of sabins is determined by multiplying the noise reduction coefficients of different surfaces within the station by the surface area of that material.

Sound Transit has established a maximum limit for reverberation time of 1.5 seconds at the platform to preserve the intelligibility of the amplified announcements. All three of the stations in the Central Bellevue Segment are open to the outside and this openness ensure that reverberation times will not exceed the design goal. The Sound Transit Design Criteria are the only criteria that apply to the acoustical design of the stations and there will be no need for any acoustical treatments at the three stations in this segment.

Mitigation measures for station noise at the three stations in this segment include using low level speakers at listener ear height and a reader board for announcements in place of the public address (PA) system during nighttime and early morning hours (10 p.m. to 7 a.m.) and lowering the noise level of the audible warning devices during these same nighttime hours. In order to ensure compliance with the maximum permissible noise levels, the applicant will be required to direct sound to the platform area and comply with required noise levels at receiving properties to minimize noise levels audible on adjacent properties. Monitoring of the

stationary noise will be required to commence upon the initiation of system testing. Additional noise reduction measures (such as reduction of reflective surfaces or the addition of acoustically absorptive surfaces in the station platform area) may be required by the DSD director if the PA system does not comply with maximum permissive noise levels on adjacent properties. This condition is reasonable, necessary to ensure that operations are maintained consistent with the Bellevue Noise Control Code, and is supported by evidence and the opinions of the City's technical expert Julie Wiebusch and the Greenbusch Group. **Refer to Condition of Approval contained in Section XI of this staff report.**

Construction Noise

Expanded hours may be approved by the Land Use Director per BCC 9.18.020.C pursuant to a Construction Noise Expanded Exempt Hours permit. Restricting the construction hours will reduce noise impacts to neighboring properties. Expanded construction hours during evening or early morning hours shall be limited to those activities which require a continuous 24 hour period or other activities which will negatively impact utility service or the transportation system. In addition, the contractor must use the best available noise abatement technology consistent with feasibility during construction. If approval of expanded exempt hours is requested, the applicant will be required to provide a construction hotline, develop a plan for public outreach, provide notice prior to the commencement of construction, monitor noise and periodically review practices during the course of the exemption period. **Refer to Condition of Approval regarding construction hours and use of best available noise abatement technology in Section XI of this report.**

VIII. CHANGES TO PROPOSAL DUE TO PUBLIC, CAC, AND CITY REVIEW

Many changes have been made to the proposal prior to permit application and during the collaborative design process at the pre-development stage. As discussed throughout this staff report changes or conditions of approval have been placed on this application due to staff and CAC review. The majority of changes are detailed in Section IV and VII of the staff report.

IX. DESIGN AND MITIGATION PERMIT DECISION CRITERIA (LUC 20.25M.030.C.3)

Below is a discussion of how the proposal has met the decision criteria for the Design and Mitigation Permit request. Compliance with each of these criteria has been demonstrated in the project application and supporting documents, and is discussed in various places in this Staff Report.

A proposal for a RLRT system or facility may be approved or approved with conditions; provided, that such proposal satisfies the following criteria:

- a. **The applicant has demonstrated compliance with the CAC Review requirements of LUC 20.25M.035; and**

Finding: Sound Transit has demonstrated compliance with CAC review requirements by attending and presenting materials regarding the East Link Light Rail System and Facilities at CAC meetings held the 1st and 3rd Wednesday of each month. In addition to the regularly scheduled meetings Sound Transit and City staff provided tours of the existing Central Link Light Rail System and Facilities and proposed East Link route in the City of Bellevue including the Central Bellevue Segment. The materials provided by Sound Transit during the pre-development and Design and Mitigation Permit review phases resulted in advisory documents consistent with LUC 20.25M.035.C.5. The final Design and Mitigation Permit CAC recommendation was transmitted to the Development Services Department director on September 29, 2015. Agenda packet materials and minutes from the CAC meetings are available for review in the project file.

- b. **The proposal is consistent with the Comprehensive Plan including without limitation the Light Rail Best Practices referenced in Comprehensive Plan Policy TR-75.2 and the policies set forth in LUC 20.25M.010.B.7; and**

Finding: The East Link Project has demonstrated consistency with the numerous Comprehensive Plan Policies that are applicable to light rail (LU-9, LU-22, LU-24, ED-3, TR-75.1, TR-75.2, TR-75.5, TR-75.7, TR-75.8, TR-75.9, TR-75.12, TR-75.15, TR-75.17, TR-75.18, TR-75.20, TR-75.22, TR-75.23, TR-75.27, TR-75.28, TR-75.32, TR-75.33, TR-75.34, TR-75.35, TR-118 and UT-39).

The alignment location and profile for East Link was approved by the Bellevue City Council and the Sound Transit Board. The design of this proposal using this alignment is consistent with the Comprehensive Plan and Light Rail Best Practices which focus on community and neighborhoods, community involvement, connecting people to light rail, land use, street design and operations, system elements (elevated, at-grade, and tunnel), property values, station security, and construction impacts and mitigation. Details of project compliance are provided detailed throughout this staff report including consistency with context requirements, design standards, and design guidelines.

- c. **The proposal complies with the applicable requirements of this Light Rail Overlay District; and**

Finding: Compliance with all elements of the Light Rail Overlay District has been demonstrated by the analysis included in this Design and Mitigation Permit staff report. See Sections II, III, IV, and IX for a discussion of overlay compliance.

- d. **The proposal addresses all applicable design guidelines and development standards of this Light Rail Overlay District in a manner which fulfills their purpose and intent; and**

Finding: As discussed above in Staff Report Section IV, the proposal addresses all applicable elements of LUC 20.25M.040 and 20.25M.050.

- e. **The proposal is compatible with and responds to the existing or intended character, appearance, quality of development and physical characteristics of the subject property and immediate vicinity; and**

Finding: The Central Bellevue Segment of East Link must comply with all applicable context setting requirements as discussed in this staff report in Section II. Sound Transit has demonstrated that the design of the Central Bellevue Segment responds to the physical characteristics of the vicinity and is intending to provide a significant regional resource that will reflect the unique character of the City of Bellevue.

- f. **The proposal will be served by adequate public facilities including streets, fire protection, and utilities; and**

Finding: Adequate public facilities are available to serve East Link in Central Bellevue. There is on-going coordination with city and private utility providers to ensure adequate service is maintained. Utility work is currently underway and Sound Transit and the City of Bellevue are coordinating with Puget Sound Energy to address any impacts related to the light rail alignment.

- g. **The proposal complies with the applicable requirements of the Bellevue City Code, including without limitation those referenced in LUC 20.25M.010.B.8; and**

Finding: Development, construction and operation of the RLRT system and facilities will comply with applicable Bellevue City Codes, including the noise control code and environmental procedures code as discussed in detail in Sections II, III, IV, VI, VII, and VIII of this staff report.

- h. **The proposal is consistent with any development agreement or Conditional Use Permit approved pursuant to subsection B of this section; and**

Finding: While the project was not permitted by development agreement or conditional use permit pursuant to LUC 20.25M.030.B, the alignment and light rail facilities were approved by the Bellevue City Council and the Sound Transit Board are reflected in this proposal and are consistent with the applicable terms of the Memorandum of Understanding in City Resolution 8322.

- i. **The proposal provides mitigation sufficient to eliminate or minimize long-term impacts to properties located near the RLRT facility or system, and sufficient to comply with all mitigation requirements of the Bellevue City Code and other applicable state or federal laws.**

Finding: Sound Transit has been required to avoid, minimize, and mitigate anticipated long-term impacts to properties located near the light rail system and facilities by adhering to required landscape development requirements, noise mitigation conditions, and compliance with critical areas protection and mitigation as discussed in detail in Sections IV and VII.

- j. **When the proposed RLRT facility will be located, in whole or in part, in a critical area regulated by Part 20.25H LUC, a separate Critical Areas Land Use Permit shall not be required, but such facility shall satisfy the following additional criteria:**
- i. **The proposal utilizes to the maximum extent possible the best available construction, design and development techniques which result in the least impact on the critical area and critical area buffer; and**
 - ii. **The proposal incorporates the performance standards of Part 20.25H LUC to the maximum extent applicable; and**
 - iii. **The proposal includes a mitigation or restoration plan consistent with the requirements of LUC 20.25H.210; except that a proposal to modify or remove vegetation pursuant to an approved Vegetation Management Plan under LUC 20.25H.055.C.3.i shall not require a mitigation or restoration plan.**

Finding: Mitigation and restoration requirements per LUC 20.25H have been incorporated into the design of the East Link project and a detailed discussion of critical areas compliance is located in Section IV of this staff report. Impacts to critical areas in the Central Bellevue Segment are discussed in detail in Section IV of this staff report. Receiving mitigation sites to mitigate for impacts to wetlands and streams along the entire East Link alignment are located in the South Bellevue and Bel Red Segments and another site is located outside of the project area in the Coal Creek Basin.

X. DECISION

After conducting the various administrative reviews associated with the proposal, including applicable Land Use consistency, City Code, and Standard compliance reviews, the Director does hereby **APPROVE WITH CONDITIONS** the East Link Central Bellevue Segment Design and Mitigation Permit.

XI. CONDITIONS OF APPROVAL:

Compliance with City Codes and Documents

The applicant shall comply with all applicable Bellevue City Codes, Standards, and Ordinances, including, but not limited to the following:

Applicable Ordinances	Codes,	Standards	and	Contact Person
-----------------------	--------	-----------	-----	----------------

Clearing & Grading Code – BCC 23.76

Construction Codes – BCC Title 23

Fire Code – BCC 23.11

Land Use Code – BCC Title 20

Environmental Procedures Code –
BCC Title 22.02

Noise Control – BCC 9.18

Right of Way Use Code – BCC 14.30

Sign Code – BCC Title 22

Transportation Code – BCC 14.60

Utility Code – BCC Title 24

Tom McFarlane, 425-452-5207

Bldg. Desk, 425-452-4121

Travis Ripley, 425-452-6042

Matt Jackson, 425-452-2729

Matt Jackson, 425-452-2729

Matt Jackson, 425-452-2729

Tim Stever, 425-452-4294

Matt Jackson, 425-452-2727

Abdy Farid, 425-452-7698

Art Chi, 425-452-4119

The following conditions are imposed on the applicant under the authority referenced:

A. GENERAL CONDITIONS: The following conditions apply to all phases of development.

1. Noise and Construction Hours

The proposal will be subject to normal construction hours of 7 a.m. to 6 p.m., Monday through Friday and 9 a.m. to 6 p.m. Saturdays, except for Federal holidays and as further defined by the Bellevue City Code. Upon written request to DSD, work hours as stated in Chapter 9.18 BCC can be extended if the criteria for extension of work hours can be met and the appropriate mitigation employed. If extended work hour approval is granted, the following conditions shall be attached to the Construction Noise Expanded Exempt Hours Permit (LY) approval in addition to any specific criteria required for the requested exemption.

- Sound Transit or its agent shall establish a 24 hour construction hotline to provide a single point of contact for construction inquiries and complaints per the terms included in the permit submittal. However, complaints received by Code Compliance during work hours and City of Bellevue Police during evening hours will be directed back to the 24 hour hotline. The City of Bellevue and Sound Transit will maintain logs of complaint activity and that information will be shared between agencies.
- A plan for public outreach shall be undertaken by Sound Transit public outreach staff. Once the construction permit is issued for the Central Bellevue segment, Sound Transit will be responsible for implementing the public outreach plan and a pro-active program of notification and communication identified in the permit application including, but not limited to, an "informational" public meeting attended by both agencies and construction contractor a minimum

of 30 days prior to the start of any heavy civil construction, early written notice of construction activities, hosting public meetings, and communicating with businesses in the vicinity. Sound Transit's contractor will be required to participate in all public outreach activities and meetings.

- A minimum of 14 days prior to the commencement of the construction activity in the Central Bellevue segment, Sound Transit or its agent shall provide notice to the City of Bellevue and properties within 1,000 feet of the active construction areas. The form of the communication shall be developed by consensus between the two agencies. Copies of the notice shall be provided to the Development Services Department when they are provided to affected property owners.
- The City of Bellevue or its agent shall conduct a one year review of construction noise levels and mitigation and may modify the terms and conditions of this approval as needed if it is determined that the current approval and current conditions are not adequately protecting the public health and safety or reasonably controlling or mitigating the construction noise, or that there are more reasonable methods of doing so based on best management practices.

AUTHORITY: Bellevue City Code 9.18.020.C & 9.18.040
REVIEWER: Matthews Jackson, Development Services
Department

2. Conceptual Utilities Approval

Utility Department approval of this Design and Mitigation Permit application is based on the conceptual design only. Changes to the site layout may be required to accommodate the utilities after utility engineering is approved.

AUTHORITY: Bellevue City Code 24.02, 24.04, 24.06
REVIEWER: Arturo Chi, Utilities Department

3. Utilities Developer Extension Agreements

The water, sewer, and storm drainage systems shall be designed per current City of Bellevue Utility Codes and Utility Engineering Standards. All design review, plan approval, and field inspection shall be performed under the Utility Developer Extension Agreements.

AUTHORITY: Bellevue City Code 24.02, 24.04, 24.06
REVIEWER: Arturo Chi, Utilities Department

4. Holiday Construction & Traffic Restrictions

Construction activities such as hauling and lane closures between November 15th and January 5th may be restricted during some hours in

some areas, due to holiday traffic. Any such restrictions will be conditions of a Right of Way Use Permit.

AUTHORITY: Bellevue City Code 14.30.060
REVIEWER: Tim Stever, Transportation Department

B. PRIOR TO CLEARING & GRADING PERMIT: These conditions must be complied with on plans submitted with the Clearing & Grading or Demolition permit application:

1. Right-of-Way Use Permit

Prior to issuance of any construction or clearing and grading permit, the applicant shall secure applicable right-of-way use permits from the City's Transportation Department, which may include:

- a) Designated truck hauling routes.
- b) Truck loading/unloading activities.
- c) Location of construction fences.
- d) Hours of construction and hauling.
- e) Requirements for leasing of right of way or pedestrian easements.
- f) Provisions for street sweeping, excavation and construction.
- g) Location of construction signing and pedestrian detour routes.
- h) All other construction activities as they affect the public street system.

In addition, the applicant shall submit for review and approval a plan for providing pedestrian access during construction of this project. Access shall be provided at all times during the construction process, except when specific construction activities such as shoring, foundation work, and construction of frontage improvements prevent access. General materials storage and contractor convenience are not reasons for preventing access.

The applicant shall secure sufficient off-street parking for construction workers before the issuance of a clearing and grading, building, a foundation or demolition permit.

AUTHORITY: Bellevue City Code 11.70 & 14.30
REVIEWER: Tim Stever, Transportation Department

2. Construction Plans

Civil engineering plans produced by a qualified engineer must be approved by the Transportation Department and other City departments prior to issuance of any clearing and grading permit. The design of all street frontage improvements, driveway accesses, and other work within any street right of way must be in conformance with the Americans with Disabilities Act, the Transportation Development Code, the Transportation

Department Design Manual, and specific requirements stated elsewhere in this document, except where deviations from such requirements have been approved by the City during previous review cycles or may be approved through subsequent review. At the City's discretion, deviations from standard requirements may be approved through the Deviations, Exceptions, and MEF process. All relevant standard drawings from the Transportation Department Design Manual should be copied exactly into the engineering plans. Requirements for the engineering plans include, but are not limited to:

- a) Traffic signs and markings.
- b) Curb, gutter, sidewalk, and driveway approach design.
- c) Handicapped ramps, crosswalk revisions, and crosswalk equipment such as pushbuttons.
- d) Installation or relocation of streetlights, traffic signals, and related equipment.
- e) Sight distance. (Show the required sight triangles and include any sight obstructions, including those off-site.)
- f) Location of fixed objects in any sidewalk or near any driveway approach.
- g) Trench restoration within any right of way or access easement.

AUTHORITY: Bellevue City Code 14.60, Transportation Department Design Manual, and Design Manual Standard Drawings

REVIEWER: Abdy Farid, Transportation Department

3. Mid Tunnel Headhouse Landscape Treatment

Working in coordination with the Development Services and Parks Departments, an enhanced landscape treatment shall be implemented in the immediate vicinity of the mid tunnel headhouse. This should be submitted as a revision to the appropriate clearing and grading permit prior to issuance.

AUTHORITY: Land Use Code 20.25M.040.C.2

REVIEWER: Matthews Jackson, Development Services Department

C. PRIOR TO ISSUANCE OF BUILDING PERMIT: Unless specified otherwise below, these conditions must be complied with on plans submitted with the Building Permit Application:

1. Building and Site Plans – Station and Other Structures

The building grade and elevations for the station and any other structures that require a building permit shall be consistent with the curb and sidewalk grade shown in the approved civil engineering plans. During construction, city inspectors may require additional survey work at any

time in order to confirm proper elevations. Building plans, landscaping plans, and architectural site plans must comply with vehicle and pedestrian sight distance requirements wherever relevant.

AUTHORITY: Bellevue City Code 14.60.060, 110, 120, 150, 180, 181, 190, 240, 241

REVIEWER: Abdy Farid, Transportation Department

2. Mechanical Equipment

Any mechanical equipment screening shall be consistent with the landscape development requirements of LUC 20.25M.C and shall be context sensitive. Any installed mechanical units shall be reviewed at final inspection and a decision shall be made at that time whether addition screening will be required.

AUTHORITY: Land Use Code 20.25M.040.F

REVIEWER: Matthews Jackson, Development Services Department

3. Planting in Right-of-Way/Streetscape

a) Planting shall be done according to the Parks and Community Services Department Best Management Practices and Design Standards in place at the time of construction.

b) A Parks Department representative shall be on-site to inspect street trees **prior to planting** and **at the time of planting** to observe the installation. Contact Parks Department Resource Management at (425) 452-6855 at least 24 hours before planting to schedule the inspection.

AUTHORITY: Land Use Code 20.25M.040.C.1.c.iv

REVIEWER: Matthews Jackson, Development Services Department
Tom Kuykendall, Parks and Community Services Department

4. Lighting

To protect adjacent properties and vehicular traffic in the right-of-way, all exterior lighting fixtures shall utilize cutoff shield or other appropriate measures to conceal the light source. There shall be no light spillover glare beyond the site boundaries.

The applicant shall submit manufacturers' cut-sheets/information for all exterior lighting fixtures to demonstrate that cutoff shields or other appropriate measures are being used to conceal the light source from adjacent properties and rights-of-way.

AUTHORITY: Land Use Code 20.25M.
REVIEWER: Matthews Jackson, Development Services
Department

5. Noise Wall Materials

Prior to building permit issuance for the noise wall, Sound Transit shall submit revised plans that indicate a stacked stone or brick type pattern with variegated earth tones for noise walls. The design should reflect Ashlar stone walls or an equivalent. The wall shall be consistent with the walls located within the adjacent South Bellevue Segment.

AUTHORITY: Land Use Code 20.25M.050.B
REVIEWER: Matthews Jackson, Development Services Department

6. Variable Seating Heights

In order to accommodate the broad range of light rail rider ages and mobility, Sound Transit shall incorporate variable seating heights. Building permit plans shall reflect seat locations and types. All seating must satisfy any applicable ADA requirements.

AUTHORITY: Land Use Code 20.25M.050.C
REVIEWER: Matthews Jackson, Development Services
Department

D. PRIOR TO TRAIN OPERATION: The following conditions are required by City Code and supported by City Policy and shall be complied with prior to train operation:

1. Street Tree Infrastructure Improvements

All street infrastructure improvements and other required transportation elements, including street light and traffic signal revisions, must be constructed by the applicant, or relocated as needed, and accepted by the Transportation Department Inspector. All required improvements must be constructed per the approved plans or per direction of the Transportation Department inspector or as decided in formal agreements between the City of Bellevue and Sound Transit. Vehicle and pedestrian sight distance requirements shall be achieved wherever relevant.

AUTHORITY: Bellevue City Code 14.60, Comprehensive Plan
Policy UT-39, Transportation Department Design
Manual, and Transportation Department Standard
Drawings.
REVIEWER: Abdy Farid, Transportation Department

2. Pavement Restoration

Pavement restoration associated with street improvements or to repair damaged street surfaces shall be provided as prescribed by Right of Way Use Permits issued prior to or at the time of construction.

AUTHORITY: Bellevue City Code 14.60.250; Design Manual Design Standard #23
REVIEWER: Tim Stever, Transportation Department

3. Easements

New sidewalk / utility easements shall be granted to the City to include all areas to the back of the future City sidewalk that are not within existing sidewalk easements or within existing or future right of way. Easements to include retaining walls will be provided wherever a retaining wall is necessary to support a City street, sidewalk, or related feature. New easements shall be granted to the City for the location of signal and street light hardware and related facilities that would not be within existing or future right of way or sidewalk easement areas. Any existing utility easements impacted by this development must be mitigated or easements relinquished.

AUTHORITY: Bellevue City Code 14.60.100
REVIEWER: Abdy Farid, Transportation Department

4. Dedication of Right of Way

New right of way shall be dedicated to the City to the back of any new or existing curb line along any City street where the new or existing curb will not be within existing City right of way. Dedication of new right of way to the City shall utilize forms and procedures acceptable to the City.

AUTHORITY: Bellevue City Code 14.60.090
REVIEWER: Abdy Farid, Transportation Department

5. Landscape Maintenance

The applicant shall maintain all installed landscaping per the terms of Section 32 90 00 of the Central Bellevue (E335) Contract Specifications Volume 2 (4 of 4) which establishes the provision of adequate and proper care for plant materials and landscape areas within the Contract limits for a minimum period of 1 year (365 days) to ensure healthy, vigorous growth of planted material. The Contractor is responsible to maintain the irrigation system for the entire planting establishment period.

AUTHORITY: Land Use Code 20.20.520.K
REVIEWER: Matthews Jackson, Development Services Department

6. Ownership and Maintenance of Landscape Screening Within RLRT Transition Area

Landscape screening located within the required 30-foot setback from the RLRT track alignment is owned by the Regional Transit Authority. The landscape screening located outside the required setback from the RLRT track alignment may be located on property owned in fee by a Regional Transit Authority, on an easement, or on private property where access entry was secured for landscape installation.

Landscape screening is required to be maintained by the Regional Transit Authority for the life of the project. Maintenance of landscape screening may be reassigned to the underlying property owners pursuant to a voluntary written agreement filed with the Development Services Department and King County Recorder's Office or its successor agency.

AUTHORITY: Land Use Code 20.25M.040.C.3.c and d
REVIEWER: Matthews Jackson, Development Services
Department

Noise Conditions

The following conditions are reasonable, necessary to ensure that operations are maintained consistent with impacts predicted in the East Link FEIS and other additional documents, supported by evidence and the opinions of the City's technical expert Julie Wiebusch of the Greenbusch Group, and are imposed under the Bellevue City Code or SEPA authority referenced:

7. Sound Transit shall implement the Record of Decision Commitments and EIS Mitigation Recommendations contained in the noise analysis listed in the Section VII of this staff report.

AUTHORITY: Comprehensive Plan Policies TR-75.17 and TR-118
REVIEWER: Matthews Jackson, Development Services
Department

8. Light Rail Vehicle Design and Operation

Light rail vehicles designed for use on the portion of East Link that passes through Bellevue shall be designed and operated to meet FTA and City required noise levels through the use of wheel skirts (that cover the wheel wells and reduce noise from the rail-wheel interface) or other equivalent measures.

AUTHORITY: Bellevue City Code 9.18.020.B.5 and 9.18.020.G;
Comprehensive Plan Policies EN-88, TR-75.17 and
TR-118
REVIEWER: Matthews Jackson, Development Services
Department

9. Operations and Maintenance Program

The applicant shall maintain an Operations and Maintenance Program for all East Link trackwork and light rail vehicles operating in Bellevue to meet FTA and City required noise levels. This program shall at a minimum include:

- Rail grinding and replacement of worn rails.
- Vehicle wheel truing and replacement. Grind down flat spots (“wheel flats”) on the vehicle wheels, which can be caused by hard braking and can cause increases in the noise levels produced by the light rail vehicles.
- Vehicle Maintenance. Perform maintenance on items such as air conditioning units, bearings, wheel skirts, and other mechanical units on the light rail vehicles.
- Operator Training. Train operators to operate vehicles to avoid hard braking which can cause wheel flats and may also damage the track, and to identify potential wheel flats and other mechanical problems so that timely maintenance can be performed.

The applicant shall prepare a report as part of Condition D.15 below and shall submit the report to the City of Bellevue Development Services Director describing the operations and maintenance program.

AUTHORITY: Bellevue City Code 9.18.020.A.10, 9.18.020.B.5 and 9.18.020.G; Comprehensive Plan Policies EN-88, TR-75.17, TR-75.33 and TR-118
REVIEWER: Matthews Jackson, Development Services Department

10. Track Design and Construction to Address Wheel Squeal

Light rail trackwork designed for use on the portion of East Link that passes through Bellevue shall be designed and operated to include rail lubricators to reduce the potential for wheel squeal on curves with a radius of 600 feet or less. Curves with a radius of greater than 600 feet up to 1,250 feet shall be built to easily accommodate lubricators in the event that wheel squeal occurs during operations.

AUTHORITY: Bellevue City Code 9.18.020.B.5 and 9.18.020.G; Comprehensive Plan Policies EN-88, TR-75.17, TR-75.33 and TR-118.
REVIEWER: Matthews Jackson, Development Services Department

11. Train Mounted Warning Devices. Train-mounted warning devices are a safety warning device. The applicant shall provide operator training on bell and horn operation protocols. To minimize noise levels, train mounted warning devices on light rail vehicles operating in Bellevue shall direct sound forward of the vehicle in its direction of travel, and train-mounted bell sound levels shall be reduced during nighttime hours of 10 p.m. to 6

a.m. while retaining their safety effectiveness.

AUTHORITY: Bellevue City Code 9.18.020.A.10 and 9.18.020.G;
Comprehensive Plan Policies EN-88, TR-75.17, TR-
75.33 and TR-118
REVIEWER: Matthews Jackson, Development Services
Department

12. Electrical Transformers

Sound levels associated with stationary noise sources shall comply with City required noise levels at receiving properties. Additional mitigation may be required if monitoring consistent with Condition 15 below indicates that actual sound levels are not consistent with the Bellevue Noise Control Code.

AUTHORITY: Bellevue City Code 9.18.030; Comprehensive Plan
Policies EN-88, TR-75.17, and TR-118.
REVIEWER: Matthews Jackson, Development Services
Department

13. Public Address System

Public address system speakers shall direct sound to the platform area and shall comply with required City noise levels at receiving properties. Additional measures may include that the public address system have an adjustable sound level and sound levels be reduced to within 10 dBA of ambient noise levels or as required to meet the applicable speech intelligibility criteria adopted by the National Fire Protection Association (NFPA). Additional noise mitigation may be required if monitoring consistent with Condition 15 below indicates that actual sound levels are not consistent with the Bellevue Noise Control Code.

AUTHORITY: Bellevue City Code 9.18.030; Comprehensive Plan
Policies EN-88, TR-75.17, TR-75.13 and TR-118.
REVIEWER: Matthews Jackson, Development Services
Department

14. Wayside Audible Warning Devices

Wayside audible warning devices are a safety warning device. Sound levels shall be designed to meet the soft tone bell AREMA standard (75 dBA to 85 dBA at 10 feet) or as required to retain the safety effectiveness of the warning device. A copy of the AREMA Recommended Design Criteria is available in the project file.

AUTHORITY: Bellevue City Code 9.18.020.A.10 and 9.18.020.G;
Comprehensive Plan Policies EN-88, TR-75.17, TR-
75.33 and TR-118
REVIEWER: Matthews Jackson, Development Services
Department

15. Monitoring and Contingency Plan

At least 6 months prior to commencing vehicle testing and system start-up, Sound Transit shall submit for approval by the Director of the Development Services Department, a 3-year noise and vibration monitoring program for the Project to confirm that operating light rail train noise and vibration levels meet FTA ROD criteria and Design and Mitigation Permit requirements applicable at the time of this approval. Such program shall also include a noise complaint and resolution process to be approved by the Director. The 3-year period shall begin at the start of vehicle testing and system start-up prior to revenue service. Sound Transit shall monitor once during vehicle testing and system start-up and once each year for two years after revenue service begins for a total of three rounds of monitoring. Monitoring shall be conducted at representative locations where impacts and mitigation have been identified in the Design and Mitigation permit process. If measured levels show that noise or vibration attributable to the Project exceed FTA criteria or Design and Mitigation Permit requirements applicable at the time of approval, and track or light rail vehicle modifications are not sufficient to bring the Project within compliance, Sound Transit shall submit a mitigation plan within 60 days with appropriate reasonable mitigation for approval by the Director to achieve compliance. Such mitigation techniques may include, but shall not be limited to, adjustments to bells and auditory devices at stations; installation of noise walls along the guideway, rights-of-way or property boundaries; installation of track lubricators or noise insulation packages; acoustic grinding of rails or installation of rail dampers; noise baffling of stationary noise sources; and reduction of reflective surfaces or addition of acoustically absorptive surfaces. Upon approval of such mitigation plan by the Director, Sound Transit shall work to expedite installation of the approved corrective mitigation. One additional round of monitoring will be conducted to confirm compliance at the location of any exceedances if identified in the last year of the monitoring program.

AUTHORITY: Bellevue City Code 9.18.020.A.10, 9.18.020.B.5, 9.18.030 and 9.18.020.G; Comprehensive Plan Policies EN-88, TR-75.17, TR-33 and TR-118.
REVIEWER: Matthews Jackson, Development Services Department

16. Noise Walls

The permanent noise wall (other than those that are required on the light rail guideway) shall be given priority in the sequence of construction and installed as early as technically feasible and practical in the construction process in order to ensure that the permanent noise wall also provides some benefits during construction of the Project. The City, Sound Transit and their contractors will consult on the appropriate timing for installation of the permanent noise wall. Alternative solutions that achieve an

effective level of noise mitigation may be considered. The final timing of installation of the noise wall or alternatives shall be established in the clearing and grading permit for each related contract package. The noise wall, including the length and height, is depicted in the mitigation map that is Exhibit O to the Amended and Restated Umbrella Memorandum of Understanding between the City and Sound Transit dated May 6, 2015.

AUTHORITY: Comprehensive Plan Policies TR-75.17 and TR-118
REVIEWER: Matthews Jackson, Development Services
Department

17. Structure Separation Requirement Within RLRT Transition Area

No portion of any primary residential structure may be closer than 60 feet from the nearest edge of the track-way within the RLRT transition area prior to train operations. This condition becomes void once train operations are commenced.

AUTHORITY: Land Use Code 20.25M.040.B.3
REVIEWER: Matthews Jackson, Development Services
Department



LIGHT RAIL PERMITTING CITIZEN ADVISORY COMMITTEE

ADVISORY DOCUMENT

CONTEXT SETTING REVIEW PHASE - JANUARY 15, 2014

Introduction

The Light Rail Permitting Citizen Advisory Committee (CAC) was appointed by the Bellevue City Council consistent with the terms of the Light Rail Overlay regulations contained in the city's Land Use Code (LUC). Land Use Code section 20.25M.035.A describes the CAC purpose to:

1. Dedicate the time necessary to represent community, neighborhood and citywide interests in the permit review process; and
2. Ensure that issues of importance are surfaced early in the permit review process while there is still time to address design issues while minimizing cost implications; and
3. **Consider the communities and land uses through which the RLRT System or Facility passes, and set "the context" for the regional transit authority to respond to as facility design progresses***; and
4. Help guide RLRT System and Facility design to ensure that neighborhood objectives are considered and design is context sensitive by engaging in on-going dialogue with the regional transit authority and the City, and by monitoring follow-through; and
5. Provide a venue for receipt of public comment on the proposed RLRT Facilities and their consistency with the policy and regulatory guidance of paragraph 20.25M.035.E below and Sections 20.25M.040 and 20.25M.050 of this Part; and
6. Build the public's sense of ownership in the project; and
7. Ensure CAC participation is streamlined and effectively integrated into the permit review process to avoid delays in project delivery.

* Identifies the focus of this Advisory Document

Section 20.25M.035.C of the LUC guides the scope of CAC work to ensure that the Committee's intended purpose is achieved, and describes the CAC role as advisory to city staff who are charged with making decisions on the Design and Mitigation Permits required to approve light rail systems and facilities. The CAC work is intended to occur in phases that are roughly aligned with Sound Transit design phases and city permit review phases in order to achieve permit streamlining and consolidation objectives. For each phase of review, the CAC is charged with providing feedback in an Advisory Document, and city staff is charged with supporting CAC preparation of this work product (LUC 20.25M.035D.3). This written summary constitutes the Advisory Document for the Context Setting Review Phase per item #3 above.

Context Setting Review

The work product required following the Context Setting Phase of CAC review is intended to provide “context” to which Sound Transit should respond when designing elements and features of the East Link light rail system and facility, and by which permit compliance should be judged. The work of the CAC during this review phase was informed by three CAC meeting topics.

At its first meeting on October 24, 2013, the CAC toured the Central Link project to familiarize CAC members with project elements that support the Link light rail system and its associated functions, and common design features used to mitigate project impacts. At its November 20 meeting, the CAC reviewed context setting material samples assembled by city staff from presentations to and feedback from the Arts Commission and Light Rail Best Practices Committee. On that same night, Sound Transit staff presented the 130th Station design package to the CAC to determine if the submittal provided an appropriate level of detail or whether additional information was necessary for CAC members to evaluate compliance with policy and design guidelines during later CAC review phases. At its December 4th meeting the CAC toured the Bellevue subareas through which the East Link alignment, as it was approved by the Sound Transit Board and the Bellevue City Council, will pass. Members of the CAC were able to develop a more comprehensive perspective of the future alignment and its significant features, and the present context in Enatai, Surrey Downs, the commercial areas east of 112th Ave SE, Downtown, Wilburton, the vicinity of Lake Bellevue, and in Bel-Red.

Context Setting Advice

On December 18th, the CAC considered the context and design considerations that were provided in LUC 20.25M.050.B, and offered additional input that should be considered for each subarea through which the East Link alignment is proposed to pass. The context and design considerations from the Land Use Code together with the additional input provided by the CAC has been organized by subarea and general alignment sections and presented below for ease of reference. This constitutes the CAC Advisory Document on the Context Setting phase of its review, and will be used to determine whether the proposed design and mitigation complies with the context sensitivity provisions of the Land Use Code.

1. Southwest Bellevue Subarea (LUC 20.25M.050.B.1). In addition to complying with all applicable provisions of the Southwest Bellevue Subarea Plan, the design intent for the RLRT system and facility segment that passes through this subarea is to contribute to the major City gateway feature that already helps define Bellevue Way and the 112th Corridor. The RLRT system or facility design should reflect the tree-lined boulevard that is envisioned for the subarea, and where there are space constraints within the transportation cross-section, design features such as living walls and concrete surface treatments should be employed to achieve corridor continuity. The presence of the South Bellevue park and ride and station when viewed from the neighborhood above and Bellevue Way to the west, as well as from park trails to the east, should be softened through tree retention where possible and enhanced landscaping and “greening features” such as living walls and trellises. Design features

for the alignment passing through this subarea and for the East Main Station should include landscaping that provides dense screening when viewed from residential areas and visual relief along transportation rights-of-way while maintaining sightlines that ensure user safety. Design features should be incorporated to discourage vehicular drop-off activities adjacent to the single-family areas. The character of this area is defined by:

- a. The expansive Mercer Slough Nature Park;
- b. Historic references to truck farming of strawberries and blueberries;
- c. Retained and enhanced tree and landscaped areas that complement and screen transportation uses from residential and commercial development; and
- d. Unique, low-density residential character that conveys the feeling of a small town within a larger City.

The CAC advises that the following additional context and design considerations should be considered when evaluating the East Link project in the Southwest Bellevue Subarea for context sensitivity during future CAC permit review phases.

- e. The alignment transition from the I-90 right-of-way to the South Bellevue Station should be reflected as a “Grand Entry” into Bellevue. This gateway area defines Bellevue as the “City in a Park.” The gateway serves a number of functions, and should appropriately greet the different users that pass through it, including transit riders, vehicles, residents, visitors to the Mercer Slough Nature Park, bicyclists from the I-90 trail, fish (specifically salmon), and wildlife.
- f. All structures located at the South Bellevue Park and Ride and Station should be designed to express a strong ecological connection to Mercer Slough Nature Park.
- g. The South Bellevue Park & Ride garage should incorporate green/living walls and trellis structures on the roof level in addition to interesting concrete surface treatments to break down mass and scale, and to help blend the garage into the Mercer Slough Nature Park when viewed from the neighborhoods to the west and the park to the east.
- h. References to Southwest Bellevue’s truck farming history should be incorporated into the South Bellevue Station and Parking Garage.
- i. Along 112th SE design treatments and mitigation should be complementary to differing levels of development intensity that exist on the east (commercially developed) and the west (residentially developed) sides of the road.
- j. The portal and tunnel between the East Main and Downtown Stations present an opportunity to “Visually Transport” transit riders from the historic mid-century modern, stable neighborhoods of Southwest Bellevue to the bustling urban context

of the Downtown. Art on the portal and in the tunnel could help depict the transition from the suburban context to the urban context.

- k. Landscaping should be employed to soften the impact of the portal structure adjacent to the East Main Station. If art opportunities are employed, additional emphasis on the concrete mass of the East Main portal structure should be avoided.
 - l. Wayfinding at the East Main Station should include “youth friendly” information for riders who will be accessing Bellevue High School.
2. Downtown Subarea (LUC 20.25M.050.B.2). In addition to complying with all applicable provisions of the Downtown Subarea Plan, the design intent for the RLRT system and facility segment that passes through this subarea is to enhance Downtown Bellevue’s identity as an urban center that serves as the residential, economic, and cultural heart of the Eastside. The above-ground expression of the Downtown Station is envisioned as a highly utilized urban “place” with an architectural vocabulary that not only reflects and communicates the high quality urban character of Downtown as a whole, but also complements the immediately adjacent civic center uses including Bellevue City Hall, Meydenbauer Convention Center, the Transit Center, Pedestrian Corridor, and the Downtown Art Walk. The alignment crossing over I-405 will be prominent to visitors entering, leaving, and passing through the Downtown, and its design should be viewed as an opportunity to create a landmark that connects Downtown Bellevue with areas of the City to the east. The station and freeway crossing should reflect Bellevue’s branding, and should be comfortable and attractive places to be and experience, with high quality furnishings and public art that capitalize on place-making opportunities. The character of this area is defined by:
- a. Private entertainment and cultural attractions;
 - b. High quality urban amenities such as pedestrian oriented development and weather protection that encourages people to linger and not just pass through;
 - c. High rise buildings that attract a creative and innovative work force;
 - d. Multifamily developments that attract urban dwellers that are less tied to their vehicles to accomplish day-to-day tasks;
 - e. Great public infrastructure including roadways, transit and pedestrian improvements, parks and public buildings; and
 - f. Stable property values that make it a desirable place for businesses to locate and invest.

The CAC advises that the following additional context and design considerations should be considered when evaluating the East Link project in the Downtown Subarea for context sensitivity during future CAC permit review phases.

- g. The Downtown Station should convey a sense of arrival at a bustling economic hub that provides access to retail, visitor services, offices, and urban residential neighborhoods.
 - h. The station should convey a future focus on smart growth, and the importance of transit to the success of sustainable development.
 - i. The aesthetics of the station roof should be taken into account and finished to enhance views down on the Downtown station for adjacent high rise and convention center development.
 - j. Clear connectivity, accessibility, and wayfinding should be provided between the Downtown Station, the Bellevue City Hall site, and the Bus Transit Center.
3. Wilburton/NE 8th Street Subarea (LUC 20.25M.050.B.3). In addition to complying with all applicable provisions of the Wilburton/N.E. 8th Street Subarea Plan, the design intent for the RLRT system and facility segment that passes through this subarea is to focus on the hospital station's role as a gateway location to points east of Downtown on to Bel-Red and beyond. The alignment crossing over I-405 should create a cohesive connection between the Downtown and hospital stations, but the hospital station itself should have its own identity. With significant ridership anticipated to be generated from the Medical Institution District to the west, the hospital station should take design cues from the hospital, the ambulatory health care center, and the medical office buildings that were designed to be responsive to the Medical Institution Design Guidelines that are shaping the character of this area. The character of this area is emerging and design guidelines envision an area defined by:
- a. Outdoor spaces that promote visually pleasing, safe, and healing/calming environments for workers, patients accessing health care services, and visitors;
 - b. Buildings and site areas which include landscaping with living material as well as special pavements, trellises, screen wall planters, water, rock features, art, and furnishings;
 - c. Institutional landmarks that convey an image of public use and provide a prominent landmark in the community; and
 - d. Quality design, materials, and finishes to provide a distinct identity that conveys a sense of permanence and durability.

The CAC advises that the following additional context and design considerations should be considered when evaluating the East Link project in the Wilburton/NE 8th Street Subarea for context sensitivity during future CAC permit review phases.

- e. Height of the flyovers (freeway, 116th Ave NE, and NE 8th) between the Downtown Station and the Hospital Station presents unique opportunities and challenges.

- i. Design attention should be given to the under-portions of the flyover structures that will be visible from vehicles and pedestrians that pass underneath them.
 - ii. Required railings on the flyover structures could present an art opportunity if they could be employed without further emphasizing the mass of the structure.
- f. The aesthetics of the Hospital station roof should be taken into account and finished to enhance views down on the station for adjacent development on Midlakes Hill to the east and future development anticipated in the Wilburton Village.
- g. Clear connectivity, accessibility, and wayfinding should be provided between the Hospital Station and the Medical Institution District where Overlake Hospital and the Group Health Ambulatory Care Center are located.
- h. Weather protection should be provided on the route between the Hospital Station and the Medical Institution District.
- i. References to the freight hub and rail platform that served Bellevue’s historic truck farming industry should be incorporated into the Hospital Station.
- j. Physical connections and clear wayfinding should be provided between the Hospital Station and the regional trail proposed for the old Burlington Northern Railroad right-of-way.
- k. The Hospital station context should convey a sense of institutional permanence and quality that is broader in focus than accessibility to health care.

4. Bel-Red Subarea (LUC 20.25M.050.B.4). In addition to complying with all applicable provisions of the Bel-Red Subarea Plan, the design intent for the RLRT system and facility segment that passes through this subarea is to foster a new path for Bel-Red that is directed toward a model of compact, mixed use, and “smart growth” that represents a departure from the area’s historic industrial roots. The 2013 context provides only glimpses of the future that is envisioned for this area. As a result, the public investment in light rail infrastructure provides an opportunity to reinforce the future outcomes that are desired for the area. The desired future character of this area is undefined by current development, but the Bel-Red Subarea Plan envisions a condition that is defined by:

- a. A thriving economy anchored by major employers, businesses unique to the subarea, and services important to the local community;
- b. Vibrant, diverse, and walkable neighborhoods that support housing, population, and income diversity;
- c. A comprehensive and connected parks and open space system;

- d. Environmental improvements resulting from redevelopment;
- e. A multimodal transportation system;
- f. An unique cultural environment;
- g. Scale of development that does not compete with Downtown, and provides a graceful transition to residential areas farther to the east; and
- h. Sustainable development using state of the art techniques to enhance the natural and built environment and create a livable community.

The CAC found the context and design considerations for the Bel-Red Subarea in LUC 20.25M.050.B.4 to be very thorough. The CAC advises that wayfinding to and from the 120th Street Station should receive special attention to ensure that pedestrians are able to easily locate the station within the larger Spring District complex.

5. General Alignment. In addition to the subarea specific context advice provided above, the CAC advises that the following context and design considerations should be taken into account across the entire East Link alignment.
 - a. Art should be used to tell the history of Bellevue
 - b. Stations and associated features and amenities should be accessible to all users.
 - c. Signage and wayfinding should create continuity across the alignment and individuality that helps define and enhance specific points of interest along the alignment.
 - d. Light rail through Bellevue should be a “two way experience” for riders, and opportunities for art, design, landscaping and architectural detail should be considered when viewed from trains traveling to both Redmond and Seattle.
 - e. Visual simulations of sensitive view sheds (such as views of the South Bellevue Parking Garage from Mercer Slough Nature Park and Enatai) would be useful for assessing context sensitivity during future phases of CAC review.

Next Steps

The advice contained in this Advisory Document should be forwarded to Sound Transit for use in refining its design of elements and features of the East Link light rail system. This advice should also be shared with the Arts Commission as they evaluate arts opportunities and commission art associated with the East Link project, and with Wright Runstad as the company progresses in the design and development of the Spring District project. Context setting completed by the Light Rail Permitting CAC may also help inform development of character profiles during future work undertaken as part of the Station Area planning program.



LIGHT RAIL PERMITTING CITIZEN ADVISORY COMMITTEE

ADVISORY DOCUMENT EAST MAIN SEGMENT PRE-DEVELOPMENT REVIEW MAY 16, 2014

Introduction

The Light Rail Permitting Citizen Advisory Committee (CAC) was appointed by the Bellevue City Council consistent with the terms of the Light Rail Overlay regulations contained in the city's Land Use Code (LUC). Land Use Code section 20.25M.035.A describes the CAC purpose to:

1. Dedicate the time necessary to represent community, neighborhood and citywide interests in the permit review process; and
2. **Ensure that issues of importance are surfaced early in the permit review process while there is still time to address design issues while minimizing cost implications***; and
3. Consider the communities and land uses through which the RLRT System or Facility passes, and set "the context" for the regional transit authority to respond to as facility design progresses; and
4. **Help guide RLRT System and Facility design to ensure that neighborhood objectives are considered and design is context sensitive by engaging in on-going dialogue with the regional transit authority and the City, and by monitoring follow-through***; and
5. **Provide a venue for receipt of public comment on the proposed RLRT Facilities and their consistency with the policy and regulatory guidance of paragraph 20.25M.035.E below and Sections 20.25M.040 and 20.25M.050 of this Part; and**
6. **Build the public's sense of ownership in the project***; and
7. Ensure CAC participation is streamlined and effectively integrated into the permit review process to avoid delays in project delivery.

* Identifies the focus of this Advisory Document

Pre-Development Review

This phase of review is intended to provide feedback regarding effectiveness at incorporating contextual direction into the early phases of design. The CAC is expected to provide advice regarding complementary building materials, integration of public art, preferred station furnishings from available options, universal design measures to enhance usability by all people, quality design, materials, landscape development, and tree retention. The CAC is to provide

further input and guidance, based on the input and guidance provided in the context setting phase, on compliance (or lack of compliance) with the policy and regulations and whether information is sufficient to evaluate such compliance.

CAC Work Product

The work of the CAC at each review stage will culminate in a CAC Advisory Document that describes the phase of review and CAC feedback. The work product required following the Pre-Development Phase of CAC review is intended to provide Sound Transit with early guidance and advice that is integrated into future Design and Mitigation Permit submittals.

At the February 19th, 2014 CAC meeting Sound Transit presented its pre-development review stage package for the East Main Segment. The CAC continued to discuss the East Main Segment at the March 5th, 2014 and March 19th, 2014 meetings.

The following represents the CAC advisory comments regarding LUC 20.25M.040, 20.25M.050, and context setting sensitivity.

20.25M.040 RLRT system and facilities development standards

1. Building Height – No concerns expressed by the CAC. More project specific information will be included during the Design and Mitigation Permit review stage.
2. Setbacks – No concerns expressed by the CAC. More project specific information will be included during the Design and Mitigation Permit review stage.
3. Landscape Development
 - The CAC recommends Sound Transit to explore the use of grasscrete for the turnaround area for emergency vehicles.
4. Fencing – No concerns were expressed by the CAC. More project specific information will be included during the Design and Mitigation Permit review stage.
5. Light and Glare - The No concerns expressed by the CAC. More project specific information will be included during the Design and Mitigation Permit review stage.
6. Mechanical Equipment - No concerns were expressed by the CAC. More project specific information will be included during the Design and Mitigation Permit review stage.
7. Recycling and Solid Waste - No concerns were expressed by the CAC. More project specific information will be included during the Design and Mitigation Permit review stage.
8. Critical Areas - No concerns expressed by the CAC. More project specific information will be included during the Design and Mitigation Permit review stage.

9. Use of City Right of Way - No concerns expressed by the CAC. More project specific information will be included during the Design and Mitigation Permit review stage.

20.25M.050 Design guidelines

1. Design Intent - In addition to complying with all applicable provisions of the Southwest Bellevue Subarea Plan, the design intent for the Regional Light Rail Train system and facility segment that passes through this subarea is to contribute to the major City gateway feature that already helps define Bellevue Way and the 112th Corridor. The Regional Light Rail Train system or facility design should reflect the tree-lined boulevard that is envisioned for the subarea, and where there are space constraints within the transportation cross-section, design features such as living walls and concrete surface treatments should be employed to achieve corridor continuity. The presence of the South Bellevue park and ride and station when viewed from the neighborhood above and Bellevue Way to the west, as well as from park trails to the east, should be softened through tree retention where possible and enhanced landscaping and “greening features” such as living walls and trellises.
2. Context and Design Considerations - The CAC was tasked with evaluating the existing context setting characteristics included in the Land Use Code in order to verify that the design of the station and alignment is consistent with the vision for the Southwest Bellevue. The Land Use Code states that the character of this area is defined by:
 - The expansive Mercer Slough Nature Park;
 - Historic references to truck farming of strawberries and blueberries;
 - Retained and enhanced tree and landscaped areas that complement and screen transportation uses from residential and commercial development; and
 - Unique, low density residential character that conveys the feeling of a small town within a larger City.

The CAC advised that the following additional context and design considerations should be considered when evaluating the East Link project in the Southwest Bellevue Subarea for context sensitivity during future CAC and permit review phases. The following items pertain to the East Main Segment:

- Along 112th SE design treatments and mitigation should be complementary to differing levels of development intensity that exist on the east (commercially developed) and the west (residentially developed) sides of the road.
- The portal and tunnel between the East Main and Downtown Stations present an opportunity to “Visually Transport” transit riders from the historic mid-century modern, stable neighborhoods of Southwest Bellevue to the bustling urban context

of the Downtown. Art on the portal and in the tunnel could help depict the transition from the suburban context to the urban context.

- Landscaping should be employed to soften the impact of the portal structure adjacent to the East Main Station. If art opportunities are employed, additional emphasis on the concrete mass of the East Main portal structure should be avoided.

3. Additional General Design Guidelines

- The CAC recommends both visual and audio signals installed at the stations provided they are not too obtrusive.
- The CAC recommends stone or brick for the wall along 112th so that it reflects the tree lined boulevard envisioned in the context characteristics. This could be achieved with a more natural formliner pattern rather than a smooth surface.
- The CAC recommends Sound Transit evaluate opportunities to use the tunnel portal as an opportunity for an artistic expression.
- The CAC wants Sound Transit to evaluate additional opportunities for pedestrian access to the East Main Station from the Surrey Downs neighborhood.
- The CAC wants to see detailed technical analysis of anticipated noise impacts from train construction and operations along the alignment.

Next Steps

The advice contained in this Advisory Document should be forwarded to Sound Transit for use in refining its design of elements and features of the East Link light rail system features in support of its Design and Mitigation Permit submittal.



LIGHT RAIL PERMITTING CITIZEN ADVISORY COMMITTEE

ADVISORY DOCUMENT DOWNTOWN SEGMENT PRE-DEVELOPMENT REVIEW JULY 15, 2014

Introduction

The Light Rail Permitting Citizen Advisory Committee (CAC) was appointed by the Bellevue City Council consistent with the terms of the Light Rail Overlay regulations contained in the city's Land Use Code (LUC). Land Use Code section 20.25M.035.A describes the CAC purpose to:

1. Dedicate the time necessary to represent community, neighborhood and citywide interests in the permit review process; and
2. **Ensure that issues of importance are surfaced early in the permit review process while there is still time to address design issues while minimizing cost implications***; and
3. Consider the communities and land uses through which the RLRT System or Facility passes, and set "the context" for the regional transit authority to respond to as facility design progresses; and
4. **Help guide RLRT System and Facility design to ensure that neighborhood objectives are considered and design is context sensitive by engaging in on-going dialogue with the regional transit authority and the City, and by monitoring follow-through***; and
5. **Provide a venue for receipt of public comment on the proposed RLRT Facilities and their consistency with the policy and regulatory guidance of paragraph 20.25M.035.E below and Sections 20.25M.040 and 20.25M.050 of this Part; and**
6. **Build the public's sense of ownership in the project***; and
7. Ensure CAC participation is streamlined and effectively integrated into the permit review process to avoid delays in project delivery.

* Identifies the focus of this Advisory Document

Pre-Development Review

This phase of review is intended to provide feedback regarding effectiveness at incorporating contextual direction into the early phases of design. The CAC is expected to provide advice regarding complementary building materials, integration of public art, preferred station furnishings from available options, universal design measures to enhance usability by all people, quality design, materials, landscape development, and tree retention. The CAC is to provide

further input and guidance, based on the input and guidance provided in the context setting phase, on compliance (or lack of compliance) with the policy and regulations and whether information is sufficient to evaluate such compliance.

CAC Work Product

The work of the CAC at each review stage will culminate in a CAC Advisory Document that describes the phase of review and CAC feedback. The work product required following the Pre-Development Phase of CAC review is intended to provide Sound Transit with early guidance and advice that is integrated into future Design and Mitigation Permit submittals.

At the March 19th, 2014 CAC meeting Sound Transit presented its pre-development review stage package for the Downtown Segment which includes both the Downtown Transit Center and Hospital Stations. The CAC continued to discuss the Downtown Segment at the April 2nd, 2014, April 16th, 2014, and May 7th, 2014 meetings.

The following represents the CAC advisory comments regarding LUC 20.25M.040, 20.25M.050, and context setting sensitivity.

20.25M.040 RLRT system and facilities development standards

1. Building Height – No concerns expressed by the CAC. More project specific information will be included during the Design and Mitigation Permit review stage.
2. Setbacks – No concerns expressed by the CAC. More project specific information will be included during the Design and Mitigation Permit review stage.
3. Landscape Development
 - The CAC recommends that landscape development at the Hospital Station, particularly in the vicinity of NE 8th Street, be designed in a way which does not create a site obstruction for motorists.
4. Fencing – No concerns were expressed by the CAC. More project specific information will be included during the Design and Mitigation Permit review stage.
5. Light and Glare - No concerns expressed by the CAC. More project specific information will be included during the Design and Mitigation Permit review stage.
 - The CAC recommends that no stations should have up lights that could shine into neighboring buildings or residential areas. All lighting should remain within the confines of the stations to the greatest extent possible.
6. Mechanical Equipment - No concerns were expressed by the CAC. More project specific information will be included during the Design and Mitigation Permit review stage.

7. Recycling and Solid Waste - No concerns were expressed by the CAC. More project specific information will be included during the Design and Mitigation Permit review stage.
8. Critical Areas - No concerns expressed by the CAC. More project specific information will be included during the Design and Mitigation Permit review stage.
9. Use of City Right of Way – See comment above regarding landscape development. More project specific information will be included during the Design and Mitigation Permit review stage.

20.25M.050 Design guidelines

1. Design Intent – Downtown Subarea - In addition to complying with all applicable provisions of the Downtown Subarea Plan, the design intent for the RLRT system and facility segment that passes through this subarea is to enhance Downtown Bellevue’s identity as an urban center that serves as the residential, economic, and cultural heart of the Eastside. The above-ground expression of the Downtown Station is envisioned as a highly utilized urban “place” with an architectural vocabulary that not only reflects and communicates the high quality urban character of Downtown as a whole, but also complements the immediately adjacent civic center uses including Bellevue City Hall, Meydenbauer Convention Center, the Transit Center, Pedestrian Corridor, and the Downtown Art Walk. The alignment crossing over I-405 will be prominent to visitors entering, leaving, and passing through the Downtown, and its design should be viewed as an opportunity to create a landmark that connects Downtown Bellevue with areas of the City to the east. The station and freeway crossing should reflect Bellevue’s branding, and should be comfortable and attractive places to be and experience, with high quality furnishings and public art that capitalize on place-making opportunities.

Design Intent – Wilburton/NE 8th Street Subarea - In addition to complying with all applicable provisions of the Wilburton/N.E. 8th Street Subarea Plan, the design intent for the RLRT system and facility segment that passes through this subarea is to focus on the hospital station’s role as a gateway location to points east of Downtown on to Bel-Red and beyond. The alignment crossing over I-405 should create a cohesive connection between the Downtown and hospital stations, but the hospital station itself should have its own identity. With significant ridership anticipated to be generated from the Medical Institution District to the west, the hospital station should take design cues from the hospital, the ambulatory health care center, and the medical office buildings that were designed to be responsive to the Medical Institution Design Guidelines that are shaping the character of this area.

2. Context and Design Considerations - The CAC was tasked with evaluating the existing context setting characteristics included in the Land Use Code in order to verify that the design of the stations and alignment is consistent with the vision for the Downtown and Wilburton/NE 8th Street Subareas. The Land Use Code states that the character of this area is defined by:

Downtown Subarea

- Private entertainment and cultural attractions;
- High quality urban amenities such as pedestrian oriented development and weather protection that encourages people to linger and not just pass through;
- High rise buildings that attract a creative and innovative work force;
- Multifamily developments that attract urban dwellers that are less tied to their vehicles to accomplish day-to-day tasks;
- Great public infrastructure including roadways, transit and pedestrian improvements, parks and public buildings; and
- Stable property values that make it a desirable place for businesses to locate and invest.

Wilburton/NE 8th Street

- Outdoor spaces that promote visually pleasing, safe, and healing/calming environments for workers, patients accessing health care services, and visitors;
- Buildings and site areas which include landscaping with living material as well as special pavements, trellises, screen wall planters, water, rock features, art, and furnishings;
- Institutional landmarks that convey an image of public use and provide a prominent landmark in the community; and
- Quality design, materials, and finishes to provide a distinct identity that conveys a sense of permanence and durability.

The CAC advised that the following additional context and design considerations should be considered when evaluating the East Link project in the Downtown Bellevue and Wilburton/NE 8th Street Subareas for context sensitivity during future CAC and permit review phases. The following items pertain to the Downtown Segment:

Downtown Subarea

The CAC advises that the following additional context and design considerations should be considered when evaluating the East Link project in the Downtown Subarea for context sensitivity during future CAC and permit review phases.

- a. The Downtown Station should convey a sense of arrival at a bustling economic hub that provides access to retail, visitor services, offices, and urban residential neighborhoods.
- b. The station should convey a future focus on smart growth, and the importance of transit to the success of sustainable development.
- c. The aesthetics of the station roof should be taken into account and finished to enhance views down on the Downtown station for adjacent high rise and convention center development.
- d. Clear connectivity, accessibility, and way finding should be provided between the Downtown Station and the Bus Transit Center.

Wilburton/NE 8th Street Subarea

The CAC advises that the following additional context and design considerations should be considered when evaluating the East Link project in the Wilburton/NE 8th Street Subarea for context sensitivity during future CAC and permit review phases.

- a. Height of the flyovers (freeway, 116th Ave NE, and NE 8th) between the Downtown Station and the Hospital Station presents unique opportunities and challenges.
 - i. Design attention should be given to the under-portions of the flyover structures that will be visible from vehicles and pedestrians that pass underneath them.
 - ii. Required railings on the flyover structures could present an art opportunity if they could be employed without further emphasizing the mass of the structure.
- b. The aesthetics of the Hospital station roof should be taken into account and finished to enhance views down on the station for adjacent development on Midlakes Hill to the east and future development anticipated in the Wilburton Village.
- c. Clear connectivity, accessibility, and way finding should be provided between the Hospital Station and the Medical Institution District where Overlake Hospital and the Group Health Ambulatory Care Center are located.
- d. Weather protection should be provided on the route between the Hospital Station and the Medical Institution District.
- e. References to the freight hub and rail platform that served Bellevue's historic truck farming industry should be incorporated into the Hospital Station.
- f. The Hospital station context should convey a sense of institutional permanence and quality that is broader in focus than accessibility to health care.

3. Additional General Design Guidelines

- The CAC recommends that the issue of lighting be uncoupled from the issue of meeting the needs of those with disabilities and that both audio and visual cues be included in station design.
- The CAC recommends that the design of the Downtown Transit Center Station should complement the existing City Hall and new plaza design while providing distinct elements that demarcate the different uses.
- The CAC recommends enhanced weather protection at the corners between the existing bus transit center and the new Downtown Transit Center Station.
- The CAC recommends that restroom facilities be incorporated into the Downtown Transit Center Station design.
- The CAC recommends that variable seating heights be provided at all light rail stations in Bellevue.
- The CAC recommends that Sound Transit include places for people to rest along the walkway connecting the Hospital Station to 116th Ave NE.
- The CAC recommends a signature treatment of the railing for the entire span from the Downtown Transit Center Station to the Hospital Station. The CAC recommends painting the underside of the elevated guideway green and for Sound Transit to look for opportunities to further enhance the aesthetics of the NE 8th Street crossing south of the Hospital Station.

In addition to the items noted above, the CAC also makes the following recommendation that should be forwarded to the Station Area Planning team:

- The CAC recommends that Sound Transit work with the City to establish a multi-purpose path for pedestrians and bicyclists over I-405.

Next Steps

The advice contained in this Advisory Document should be forwarded to Sound Transit for use in refining its design of elements and features of the East Link light rail system features in support of its Design and Mitigation Permit submittal.



LIGHT RAIL PERMITTING CITIZEN ADVISORY COMMITTEE

ADVISORY DOCUMENT - RECOMMENDATION TO THE DIRECTOR – CENTRAL BELLEVUE SEGMENT DESIGN AND MITIGATION PERMIT SEPTEMBER 29, 2015

Introduction

The Light Rail Permitting Citizen Advisory Committee (CAC) was appointed by the Bellevue City Council consistent with the terms of the Light Rail Overlay regulations contained in the city's Land Use Code (LUC). Land Use Code section 20.25M.035.A describes the CAC purpose to:

- 1. Dedicate the time necessary to represent community, neighborhood and citywide interests in the permit review process*;** and
2. Ensure that issues of importance are surfaced early in the permit review process while there is still time to address design issues while minimizing cost implications; and
- 3. Consider the communities and land uses through which the RLRT (Regional Light Rail Train) System or Facility passes, and set "the context" for the regional transit authority to respond to as facility design progresses*;** and
- 4. Help guide RLRT System and Facility design to ensure that neighborhood objectives are considered and design is context sensitive by engaging in on-going dialogue with the regional transit authority and the City, and by monitoring follow-through*;** and
5. Provide a venue for receipt of public comment on the proposed RLRT Facilities and their consistency with the policy and regulatory guidance of paragraph 20.25M.035.E below and Sections 20.25M.040 and 20.25M.050 of this Part; and
- 6. Build the public's sense of ownership in the project*;** and
- 7. Ensure CAC participation is streamlined and effectively integrated into the permit review process to avoid delays in project delivery*.**

* Identifies the focus of this Advisory Document

Design and Mitigation Permit Review — 60% Design Development Phase

This phase of review is intended to provide feedback regarding effectiveness of design and landscape development in incorporating prior guidance at context and schematic design stages. This phase is intended to provide further input and guidance, based on the input and guidance provided in the context setting phase, on compliance (or lack of compliance) with the policy and regulatory guidance of LUC 20.25M and LUC 20.25M.040 and 20.25M.050, and whether information is sufficient to evaluate such compliance. The CAC advice is based on the alignment and station design agreed to by the City of Bellevue City Council and Sound Transit Board through a Memorandum of Understanding. The CAC is charged with providing the Director of the Development Services Department with a final advisory document.

CAC Work Product

The work of the CAC at each review stage will culminate in a CAC advisory document that describes the phase of review and CAC feedback. The work product required following the Pre-Development Phase of CAC review is intended to provide Sound Transit with early guidance and advice that is integrated into future Design and Mitigation Permit submittals. This final Design and Mitigation Permit advisory document is intended to provide the Director of the Development Services Department with a recommendation to demonstrate Sound Transit compliance with Design and Mitigation Permit Decision Criteria pursuant to LUC 20.25M.030.C.3.

There were two Pre-Development CAC Advisory Documents that covered the scope of this Design and Mitigation permit. On May 16, 2014, Sound Transit was provided with the East Main Segment Pre-Development Advisory Document. On July 15, 2014, Sound Transit was provided with the Downtown Segment Pre-Development Advisory Document. These documents outlined Sound Transit compliance with context setting characteristics and early Design and Mitigation Permit requirements. The pre-development advisory documents also included several recommendations on additional items to be addressed during formal permit review.

The following represents the CAC advisory recommendation to the Development Services Department Director regarding compliance related to LUC 20.25M.030.C.3, LUC 20.25M.040, and 20.25M.050.

20.25M.030.C.3 Design and Mitigation Permit Decision Criteria

The City of Bellevue Development Services Director is responsible for insuring compliance with all Design and Mitigation Permit decision criteria as outlined below. The CAC was tasked with review and recommendation on some, but not all, decision criteria. Those criteria not discussed by the CAC are still applicable to approval of the Design and Mitigation Permit and compliance with all decision criteria will need to be demonstrated in the Director's decision.

A proposal for a RLRT system or facility may be approved or approved with conditions; provided, that such proposal satisfies the following criteria:

a. The applicant has demonstrated compliance with the CAC Review requirements of LUC 20.25M.035; and

- Sound Transit has demonstrated compliance with CAC review requirements by attending and presenting materials regarding the East Link Light Rail System and Facilities at CAC meetings held the 1st and 3rd Wednesday of each month. In addition to the regularly scheduled meetings Sound Transit and City staff provided tours of the existing Central Link Light Rail System and Facilities and proposed East Link route in the City of Bellevue including the Central Bellevue Segment.

b. The proposal is consistent with the Comprehensive Plan including without limitation the Light Rail Best Practices referenced in Comprehensive Plan Policy TR-75.2 and the policies set forth in LUC 20.25M.010.B.7; and

The CAC was not asked to do an exhaustive review of consistency with the Comprehensive Plan policies and Light Rail Best Practices. Where CAC members felt that elements of the permit were not consistent with these policies, they have recommended modifications to the permit in areas that were identified within their scope. Some CAC members expressed concern that some elements of the project that are outside of their scope were inconsistent with the Comprehensive Plan and Light Rail Best Practices. The East Link Project shall demonstrate consistency with the numerous Comprehensive Plan Policies that are applicable to light rail (LU-9, LU-22, LU-24, ED-3, TR-75.1, TR-75.2,

TR-75.5, TR-75.7, TR75.8, TR-75.9, TR-75.12, TR-75.15, TR-75.17, TR-75.18, TR-75.20, TR-75.22, TR-75.23, TR-75.27, TR-75.28, TR-75.32, TR-75.33, TR-75.34, TR-75.35, TR-118 and UT-39) and Light Rail Best Practices. This proposal shall be consistent with Light Rail Best Practices which focus on community and neighborhoods, community involvement, connecting people to light rail, land use, street and operations, system elements (elevated, at-grade, and tunnel), property values, station security, and construction impacts and mitigation. A detailed description of project compliance will be included in the issued Design and Mitigation Permit. The CAC's recommendations advocate for the City's long-term transportation and land use objectives while minimizing environmental and neighborhood impacts, balancing regional system performance.

LIGHT RAIL BEST PRACTICES

Key provisions of the Light Rail Best Practices report are included below where the CAC's recommendations and input are needed to ensure compliance or provide additional clarity.

- 1) Guiding Principle 2. Light rail should be developed in a manner that complements, not diminishes, the character and quality of Bellevue.
Light rail systems should be planned, designed, and built to fit appropriately into the local context and provide community enhancements, without shifting the community character. East Link should be designed to improve the places in Bellevue through context-sensitive design, high quality materials, and innovative urban design approaches that can protect neighborhoods and property values and provide a safe and secure environment for transit riders and neighbors.
- 2) Guiding Principle 3. Anticipate impacts and advocate for exceptional mitigation.
Light rail will reinforce Bellevue's role in the region as the population, economic, and cultural center of the Eastside. However, the benefits of the system cannot be achieved without some short-term disruption and inconvenience during construction and without making some long-term changes to the existing environment. Proven techniques to avoid, minimize, and mitigate these impacts can be employed to make the short term impacts manageable. The City should expect and advocate for exceptional mitigation throughout the project phases and seek to leverage additional local investments through light rail development.
- 3) Guiding Principle 4. Alignment profile should consider the unique qualities of each part of the community. There is not a one-size-fits-all solution for alignment profiles – at-grade, elevated, and tunnel – in Bellevue. There are trade-offs when selecting profiles for each of the three areas (south of downtown, downtown, and Bel-Red) in Bellevue. The profile should advance the land use vision for each of the areas it travels through, by conveniently connecting destinations, optimizing ridership, and minimizing impacts
- 4) Guiding Principle 5. An early, ongoing public involvement program is essential for success in Bellevue. An early, ongoing, and comprehensive program to engage stakeholders is absolutely essential to the success of light rail in Bellevue. Providing transparency about project information and decisions will increase public understanding of and comfort with the project. Engaging the community in the design of the system, particularly stations, will result in more sensitive designs and build the public's sense of ownership. Transparently sharing information and engaging the community in a meaningful two-way, ongoing planning process will increase the success of the system. As planning for East Link is currently underway, the City and Sound Transit should begin immediately to identify the next phase of the public involvement program for the East Link project.

c. The proposal complies with the applicable requirements of this Light Rail Overlay District; and

- As it will be conditioned, this application for Design and Mitigation Permit will be in compliance with all elements of the Light Rail Overlay District including RLRT system and facilities development standards. Approval of an Alternative Landscape Option and Noise Monitoring and Contingency Plan will be included as conditions of approval. The CAC has made recommendations to insure compliance with context requirements by making recommendations regarding noise wall treatments, portal design, landscaping, art opportunities, and materials within the Central Bellevue Segment.

d. The proposal addresses all applicable design guidelines and development standards of this Light Rail Overlay District in a manner which fulfills their purpose and intent; and

- The CAC reviewed and discussed the applicable design and development standards of the Light Rail Overlay District and has made recommendations intended to insure design guidelines and standards are met. Specific CAC advice is discussed below in this document.

e. The proposal is compatible with and responds to the existing or intended character, appearance, quality of development and physical characteristics of the subject property and immediate vicinity; and

- The Central Bellevue Segment of East Link must comply with all applicable zoning and context requirements. Recommendations from the CAC to mitigate impacts to residential properties near the East Main Station and Wilburton Station are responsive to the existing and intended character of this segment. Light Rail Overlay (LUC 20.25M) development standards also respond to the character within this segment.

f. The proposal will be served by adequate public facilities including streets, fire protection, and utilities; and

- The CAC was not tasked with verifying adequate public services. It is anticipated that when the light rail system is operational anticipated impacts to public facilities including streets, fire protection, and utilities will have been mitigated.

g. The proposal complies with the applicable requirements of the Bellevue City Code, including without limitation those referenced in LUC 20.25M.010.B.8; and

- Development, construction and operation of the RLRT system and facilities must comply with applicable Bellevue City Codes, including the noise control code and environmental procedures code. Technical analysis of Sound Transit submitted Noise Studies and documents will be completed by city staff and technical consultants. Any additional noise mitigation resulting from technical review will be included as conditions of approval in the Design and Mitigation Permit. The CAC has offered advice regarding the type of sound walls used and sound wall materials.

h. The proposal is consistent with any development agreement or Conditional Use Permit approved pursuant to subsection B of this section; and

- The CAC was not tasked with verifying consistency with the Memorandum of Understanding signed by the City of Bellevue and the Sound Transit Board. Plan development through the final design stage will result in expected refinements to design that is typical to any major development. Significant design changes in project

design that are within the scope of work for the CAC will be brought back to the CAC for evaluation during construction permit review.

i. The proposal provides mitigation sufficient to eliminate or minimize long-term impacts to properties located near the RLRT facility or system, and sufficient to comply with all mitigation requirements of the Bellevue City Code and other applicable state or federal laws.

- To the greatest extent possible with the chosen alignment and station design, the proposed RLRT facility and system will avoid, minimize, and mitigate anticipated long-term impacts to properties located near the light rail system and facilities. Mitigation includes, but is not limited to, enhanced landscaping, critical area planting enhancements, permanent noise walls, sound absorbing panels on the guideway, and the installation of public art.

j. When the proposed RLRT facility will be located, in whole or in part, in a critical area regulated by Part 20.25H LUC, a separate Critical Areas Land Use Permit shall not be required, but such facility shall satisfy the following additional criteria:

- i. The proposal utilizes to the maximum extent possible the best available construction, design and development techniques which result in the least impact on the critical area and critical area buffer; and
 - ii. The proposal incorporates the performance standards of Part 20.25H LUC to the maximum extent applicable; and
 - iii. The proposal includes a mitigation or restoration plan consistent with the requirements of LUC 20.25H.210; except that a proposal to modify or remove vegetation pursuant to an approved Vegetation Management Plan under LUC 20.25H.055.C.3.i shall not require a mitigation or restoration plan.
- Mitigation and restoration requirements per LUC 20.25H due to impacts to critical areas and their buffers will be incorporated into the Design and Mitigation Permit approval and have been discussed at CAC meetings. Impacts to critical areas in the Central Bellevue Segment include temporary and permanent impacts to wetlands and their buffers, and temporary and permanent impacts to Sturtevant Creek and its buffer. A total of .725 acres of temporary and permanent impacts to critical areas is anticipated within the Central Bellevue Segment. Mitigation for impacts to critical areas and their buffers per the criteria located in LUC 20.25H will occur within the project area and adjacent segments of East Link. Mitigation is required to result in a condition that is equal to or superior to the pre-existing environment. Based on staff's review of the technical reports and mitigation proposed by Sound Transit, the proposed mitigation will provide a lift in critical areas function at maturity over the existing condition.

CAC Recommendation to the Director of Development Services

At the request of the CAC, CAC Pre-Development Phase advice that has been addressed or partially addressed in the Design and Mitigation Permit submittal are included in bold for the Director's reference.

20.25M.040 RLRT system and facilities development standards

1. Landscape Development

- The CAC recommends that landscape development at the Wilburton (Hospital) Station, particularly in the vicinity of NE 8th Street, be designed in a way which does not create a site obstruction for motorists.
- The CAC recommends that vegetation retention should be maximized north of the Wilburton (Hospital) Station to provide a buffer to adjacent residential development.

2. Fencing

- Security and safety fences should be designed to meet City's codes. These fences should be designed to minimize blocked views to maintain the idea of a city in a park.

3. Light and Glare

- The CAC recommends that no stations should have up lights that could shine into neighboring buildings or residential areas. All lighting should remain within the confines of the stations to the greatest extent possible.

4. Recycling and Solid Waste

- The CAC recommends that Sound Transit work with its sustainability group to evaluate a system wide compost collection bin option at its stations.

5. Use of City Right of Way

- The CAC acknowledges that specific details regarding the use of the City ROW will be handled through the review and issuance of Right of Way Use Permits per LUC 20.25M.040.J; however, they want to emphasize the importance of limiting impacts on traffic to the best level technically feasible.

20.25M.050 Design guidelines

1. **Design Intent – Southwest Bellevue Subarea** - In addition to complying with all applicable provisions of the Southwest Bellevue Subarea Plan, the design intent for the Regional Light Rail Train system and facility segment that passes through this subarea is to contribute to the major City gateway feature that already helps define Bellevue Way and the 112th Corridor. The Regional Light Rail Train system or facility design should reflect the tree-lined boulevard that is envisioned for the subarea, and where there are space constraints within the transportation cross-section, design features such as living walls and concrete surface treatments should be employed to achieve corridor continuity. The presence of the South Bellevue park and ride and station when viewed from the neighborhood above and Bellevue Way to the west, as well as from park trails to the east, should be softened through tree retention where possible and enhanced landscaping and "greening features" such as living walls and trellises.

Design Intent – Downtown Subarea - In addition to complying with all applicable provisions of the Downtown Subarea Plan, the design intent for the RLRT system and facility segment that passes through this subarea is to enhance Downtown Bellevue's identity as an urban center that serves as the residential, economic, and cultural heart of the Eastside. The above-ground expression of the Downtown Station is envisioned as a highly utilized urban "place" with an architectural vocabulary that not only reflects and communicates the high quality urban character of Downtown as a whole, but also complements the immediately adjacent civic center uses including Bellevue City Hall, Meydenbauer Convention Center, the Transit Center, Pedestrian Corridor, and the Downtown Art Walk. The alignment crossing over I-405 will be prominent to visitors entering, leaving, and passing through the Downtown,

and its design should be viewed as an opportunity to create a landmark that connects Downtown Bellevue with areas of the City to the east. The station and freeway crossing should reflect Bellevue's branding, and should be comfortable and attractive places to be and experience, with high quality furnishings and public art that capitalize on place-making opportunities.

Design Intent – Wilburton/NE 8th Street Subarea - In addition to complying with all applicable provisions of the Wilburton/N.E. 8th Street Subarea Plan, the design intent for the RLRT system and facility segment that passes through this subarea is to focus on the hospital station's role as a gateway location to points east of Downtown on to Bel-Red and beyond. The alignment crossing over I-405 should create a cohesive connection between the Downtown and hospital stations, but the hospital station itself should have its own identity. With significant ridership anticipated to be generated from the Medical Institution District to the west, the hospital station should take design cues from the hospital, the ambulatory health care center, and the medical office buildings that were designed to be responsive to the Medical Institution Design Guidelines that are shaping the character of this area.

2. **Context and Design Considerations** - The CAC was tasked with evaluating the existing context setting characteristics included in the Land Use Code in order to verify that the design of the stations and alignment is consistent with the vision for the Southwest Bellevue, Downtown, and Wilburton/NE 8th Street Subareas. The Land Use Code states that the character of these areas is defined by:

Southwest Bellevue

- The expansive Mercer Slough Nature Park;
- Historic references to truck farming of strawberries and blueberries;
- Retained and enhanced tree and landscaped areas that complement and screen transportation uses from residential and commercial development; and
- Unique, low density residential character that conveys the feeling of a small town within a larger City.

Downtown Subarea

- Private entertainment and cultural attractions;
- High quality urban amenities such as pedestrian oriented development and weather protection that encourages people to linger and not just pass through;
- High rise buildings that attract a creative and innovative work force;
- Multifamily developments that attract urban dwellers that are less tied to their vehicles to accomplish day-to-day tasks;
- Great public infrastructure including roadways, transit and pedestrian improvements, parks and public buildings; and
- Stable property values that make it a desirable place for businesses to locate and invest.

Wilburton/NE 8th Street

- Outdoor spaces that promote visually pleasing, safe, and healing/calming environments for workers, patients accessing health care services, and visitors;
- Buildings and site areas which include landscaping with living material as well as special pavements, trellises, screen wall planters, water, rock features, art, and furnishings;
- Institutional landmarks that convey an image of public use and provide a prominent landmark in the community; and
- Quality design, materials, and finishes to provide a distinct identity that conveys a sense of permanence and durability.

The CAC advised that the following additional context and design considerations should be considered when evaluating the East Link project in the Southwest Bellevue, Downtown Bellevue, and Wilburton/NE 8th Street Subareas for context sensitivity during future CAC and permit review phases. The following items pertain to the Central Bellevue Segment:

Southwest Bellevue

- Along 112th SE design treatments and mitigation should be complementary to differing levels of development intensity that exist on the east (commercially developed) and the west (residentially developed) sides of the road.
- The portal and tunnel between the East Main and Downtown Stations present an opportunity to “Visually Transport” transit riders from the historic mid-century modern, stable neighborhoods of Southwest Bellevue to the bustling urban context of the Downtown. Art on the portal and in the tunnel could help depict the transition from the suburban context to the urban context.
- Landscaping should be employed to soften the impact of the portal structure adjacent to the East Main Station. If art opportunities are employed, additional emphasis on the concrete mass of the East Main portal structure should be avoided.

Downtown Subarea

- The Downtown Station should convey a sense of arrival at a bustling economic hub that provides access to retail, visitor services, offices, and urban residential neighborhoods.
- The station should convey a future focus on smart growth, and the importance of transit to the success of sustainable development.
- The aesthetics of the station roof should be taken into account and finished to enhance views down on the Downtown station for adjacent high rise and convention center development.
- Clear connectivity, accessibility, and way finding should be provided between the Downtown Station and the Bus Transit Center.

Wilburton/NE 8th Street Subarea

- Height of the flyovers (freeway, 116th Ave NE, and NE 8th) between the Downtown Station and the Wilburton (Hospital) Station presents unique opportunities and challenges.

- i. Design attention should be given to the under-portions of the flyover structures that will be visible from vehicles and pedestrians that pass underneath them.
 - ii. Required railings on the flyover structures could present an art opportunity if they could be employed without further emphasizing the mass of the structure.
- The aesthetics of the Wilburton (Hospital) station roof should be taken into account and finished to enhance views down on the station for adjacent development on Midlakes Hill to the east and future development anticipated in the Wilburton Village.
- Clear connectivity, accessibility, and way finding should be provided between the Hospital Station and the Medical Institution District where Overlake Hospital and the Group Health Ambulatory Care Center are located.
- Weather protection should be provided on the route between the Wilburton (Hospital) Station and the Medical Institution District.
- References to the freight hub and rail platform that served Bellevue's historic truck farming industry should be incorporated into the Wilburton (Hospital) Station.
- The Wilburton (Hospital) Station context should convey a sense of institutional permanence and quality that is broader in focus than accessibility to health care.

3. Additional General Design Guidelines

- The CAC recommends that the issue of lighting be uncoupled from the issue of meeting the needs of those with disabilities and that both audio and visual cues be included in station design.
- The CAC recommends that a decorative gate be used for access to the electrical building near the tunnel portal and East Main Station.
- The CAC recommends that the design of the Bellevue Downtown Station should complement the existing City Hall and new plaza design while providing distinct elements that differentiate the two uses.
- The CAC recommends the city work with Sound Transit to seek out opportunities for additional weather protection complementary to the plans for landscaping, art, and visual access at the Bellevue Downtown Station.
- The CAC recommends that restroom facilities be incorporated into the Bellevue Downtown Station design.
- The CAC recommends that variable seating heights be provided at all light rail stations in Bellevue.
- The CAC recommends that Sound Transit include places for people to rest along the walkway connecting the Wilburton (Hospital) Station to 116th Ave NE. **(The CAC was shown an updated graphic by Sound Transit that includes two benches along the walkway).**
- The CAC recommends a signature treatment for the railing for the entire span from the Bellevue Downtown Station to the Wilburton (Hospital) Station. The CAC recommends Sound Transit continue to use the style of rail planned for the I-405 crossing to achieve this goal.

- The CAC recommends that Sound Transit use a stacked stone or brick type pattern with variegated earth tones for noise walls south of the tunnel portal to provide continuity with the walls recommended in the adjoining South Bellevue Segment. Ashlar stone walls are one recommendation from the CAC.
- The CAC recommends a special treatment that may include art or vegetation for the surface structure at the mid tunnel access point.
- The CAC strongly recommends that Sound Transit further evaluate alternative locations for the signal house and maintenance access located in close proximity to the Lake Bellevue Condominiums.
- The CAC recommends that the city insure that Sound Transit adhere to all applicable water quality and storm drainage requirements.
- The CAC recommends that the City of Bellevue insure that Sound Transit evaluate and consider local soil conditions in station design and engineering.
- The CAC recommends that the City of Bellevue insure that Sound Transit considered all local environmental factors in their noise analysis, including, but not limited to the transmission of sound across Lake Bellevue, elevated structures on piles, and noise measurement locations.
- The CAC recommends that Sound Transit provide an interpretive sign regarding Sturtevant Creek the bridge to the pedestrian walkway.
- The CAC recommends a special artistic or architectural treatment for the elevated guideway crossing of NE 8th Street due to its prominence.
- The CAC recommends the use of concrete masonry units (CMU) for both the east and west faces of the Wilburton (Hospital) Station.
- The CAC recommends that the station area planning team or downtown livability team evaluate access to and from the Bellevue Downtown Station by pedestrians and bicyclists.

Design and Mitigation Permit Approval

The recommendations contained in this Advisory Document represent the conclusion of the CAC review of the Central Bellevue Segment Design and Mitigation Permit. The recommendations included in this document shall be incorporated into the Director's administrative decision. Departures by the Director from specific recommendations included within the CAC's Design and Mitigation Permit Advisory Document shall be limited to those instances where the Director determines that the departure is necessary to ensure that the RLRT facility or system is consistent with: (i) applicable policy and regulatory guidance contained in the Light Rail Overlay; (ii) authority granted to the CAC pursuant to this section; (iii) SEPA conditions or other regulatory requirements applicable to the RLRT system or facility; or (iv) state or federal law. Departures from the CAC Design and Mitigation Permit Advisory Document shall be addressed in the decision by the Director, and rationale for the departures shall be provided.

ATTACHMENT D

FINAL REPORT

WETLAND, STREAM, AND JURISDICTIONAL DITCH DELINEATION REPORT

SOUND TRANSIT EAST LINK EXTENSION
PROJECT

SOUTH BELLEVUE TO OVERLAKE

Prepared for

H-J-H Final Design Partners

and

Sound Transit

Prepared by

Anchor QEA, LLC

720 Olive Way, Suite 1900

Seattle, WA 98101

August 2014

TABLE OF CONTENTS

1	SUMMARY	1
1.1	Organization of This Report	5
2	INTRODUCTION	7
2.1	Purpose and Goals	7
2.2	Project Description Summary and Background	7
2.3	Project Area Description.....	9
3	WETLANDS	11
3.1	Wetland Delineation Methods	11
3.1.1	Vegetation.....	13
3.1.2	Soils	14
3.1.3	Hydrology	14
3.1.4	Wetland Classifications.....	14
3.1.5	State Wetland Rating System	15
3.1.6	State Hydrogeomorphic Classification System	16
3.1.7	Local Jurisdictions' Wetland Rating Systems and Buffer Requirements.....	16
3.1.7.1	City of Bellevue	17
3.1.8	Wetland Functions Assessment.....	17
3.1.9	Review of Existing Information	18
3.2	Wetland Determination.....	18
3.3	Wetland Descriptions	23
3.3.1	Mercer Slough Basin.....	23
3.3.1.1	Mercer Slough Wetland.....	24
3.3.1.2	Alcove Creek Wetland.....	25
3.3.1.3	Bellefield South Wetland.....	27
3.3.1.4	Bellefield North Wetland.....	28
3.3.1.5	8th Street Wetland	30
3.3.2	Sturtevant Creek Basin.....	31
3.3.2.1	Lake Bellevue Wetland	32
3.3.2.2	South Lake Wetland.....	33
3.3.2.3	Central Lake Wetland	34

3.3.2.4	North Lake Wetland.....	36
3.3.3	West Tributary Basin	37
3.3.3.1	BNSF Southwest Wetland.....	38
3.3.3.2	BNSF East Wetland	40
3.3.3.3	BNSF West Wetland	41
3.3.3.4	BNSF Northeast Wetland.....	42
3.3.3.5	BNSF Northwest Wetland	43
3.3.3.6	BNSF North Wetland	45
3.3.3.7	Kelsey West Tributary Pond Wetland	46
3.3.3.8	Kelsey West Tributary Stream Wetland	47
3.3.4	Kelsey Creek Basin	48
3.3.4.1	136th Place Wetland	49
3.3.5	Valley Creek Basin	50
3.3.5.1	SR 520 West Wetland	50
3.3.5.2	Valley Creek Wetland.....	52
3.3.5.3	SR 520 East Wetland	53
3.4	Regulatory Framework	55
3.4.1	USFWS Classification, Stream Association, and Local Wetland Inventory.....	55
3.4.2	Wetland Classifications and Ratings	56
3.4.3	Wetland Buffer Requirements.....	58
3.4.4	Wetland Functions and Values Summary.....	58
3.4.4.1	Water Quality Functions	60
3.4.4.2	Hydrologic Functions.....	60
3.4.4.3	Habitat Functions	61
3.5	Wetland Delineation and Typing Limitations.....	62
4	STREAM ORDINARY HIGH WATER MARK DELINEATION.....	63
4.1	Ordinary High Water Mark Delineation Methods	63
4.1.1	State OHWM Delineation Regulations.....	63
4.1.2	Local Jurisdictions Stream Rating System and Buffer Requirements.....	64
4.1.2.1	City of Bellevue	64
4.2	Stream Ordinary High Water Mark Results.....	65
4.3	Stream Ordinary High Water Mark Descriptions.....	66
4.3.1	Mercer Slough Basin.....	67

4.3.1.1	Stream A.....	67
4.3.1.2	Stream B	68
4.3.1.3	Wye Creek	69
4.3.1.4	Alcove Creek.....	69
4.3.2	Sturtevant Creek Basin.....	70
4.3.2.1	Sturtevant Creek.....	71
4.3.3	West Tributary Basin	72
4.3.3.1	West Tributary to Kelsey Creek	72
4.3.3.2	Stream C.....	73
4.3.4	Goff Creek Basin.....	74
4.3.4.1	Goff Creek.....	74
4.3.5	Kelsey Creek Basin	75
4.3.5.1	Unnamed Tributary to Kelsey Creek	75
4.3.6	Valley Creek Basin	76
4.3.6.1	Valley Creek	76
4.3.7	Stream Ratings and Buffers.....	77
5	JURISDICTIONAL DITCH INVESTIGATION.....	79
5.1	Jurisdictional Ditch Regulatory Background.....	79
5.2	Jurisdictional Ditch Delineation Methods.....	80
5.3	Jurisdictional Ditch Results	82
5.3.1	Jurisdictional Ditch Functions.....	84
5.3.2	Jurisdictional Ditch Mitigation Approach	84
6	REFERENCES	86
7	LIST OF PREPARERS AND CONTRIBUTORS.....	89

List of Tables

Table 1	Wetland Summary.....	4
Table 2	Stream Summary.....	5
Table 3	Wetland Plant Indicator Definitions.....	13
Table 4	City of Bellevue Wetland and Wetland Buffer Regulations	17
Table 5	Summary of Wetlands Located within the Project Area.....	22

Table 6	USFWS Wetland Classifications, Surface Water Connections, and Local Wetland Maps	55
Table 7	Summary of Ecology and Local Wetland Classifications and Ratings	57
Table 8	Summary of Functions and Values Wetland Rating Scores	59
Table 9	City of Bellevue Stream Buffer Regulations	65
Table 10	Summary of Streams Located within the Project Area	66
Table 11	Local Critical Areas Regulations Stream Rating and Buffer Distance	77
Table 12	Jurisdictional Ditch Summary	83
Table 13	Summary of Jurisdiction Ditch Dimensions.....	84

List of Figures

Figure 1	Vicinity Map	2
Figure 2	Drainage Basins in Project Area.....	20
Figure 3	NRCS Soil Map Data	21

List of Appendices

Appendix A	Sample Plot Summary Data
Appendix B	Wetland Delineation Field Data Forms
Appendix C	Washington State Department of Ecology Wetland Rating Forms
Appendix D	Resource Maps
Appendix E	Jurisdictional Ditch Field Data Forms
Appendix F	Stream Field Studies Summary

LIST OF ACRONYMS AND ABBREVIATIONS

BCC	Bellevue City Code
Bellevue	City of Bellevue
BMP	best management practice
Corps	U.S. Army Corps of Engineers
Ecology	Washington State Department of Ecology
EIS	Environmental Impact Statement
GPS	global positioning system
HCT	high-capacity transit
HGM	hydrogeomorphic
I-90	Interstate 90
LUC	City of Bellevue Land Use Code
NRCS	Natural Resource Conservation Service
NWI	National Wetland Inventory
OHWM	ordinary high water mark
PAB	palustrine aquatic bed
PEM	palustrine emergent
PFO	palustrine forested
PHS	Priority Habitats and Species
PSS	palustrine scrub-shrub
RCW	Revised Code of Washington
Redmond	City of Redmond
redox	redoximorphic
RMC	Redmond Municipal Code
ROE	right-of-entry
RPW	relatively permanent waters
Sound Transit	Central Puget Sound Regional Transit Authority
SR	State Route
USDA	U.S. Department of Agriculture
USFWS	U.S. Fish and Wildlife Service
WAC	Washington Administrative Code
WDFW	Washington State Department of Fish and Wildlife
WRIA 8	Water Resource Inventory Area 8

1 SUMMARY

The Central Puget Sound Regional Transit Authority (Sound Transit) proposes to construct and operate an eastern extension of its Link light rail transit system providing urban transportation improvements in the central Puget Sound metropolitan region. The proposed light rail extension, known as the East Link Extension Project, would connect to the existing light rail system in downtown Seattle and extend the system east to Mercer Island, Bellevue, and Redmond, improving transportation connectivity between Seattle and these communities. The 7.13-mile East Link Extension Project features evaluated in this report occur between Interstate 90 (I-90) on the east side of Lake Washington in Bellevue and State Route (SR) 520 in Redmond (Figure 1).

C:\Jobs\120975-01_01_Sound_Transit_East_Link_Env_Support\Maps\2013_09\Figure 1 (Vicinity Map).mxd cgardner 9/16/2013 10:19:08 AM

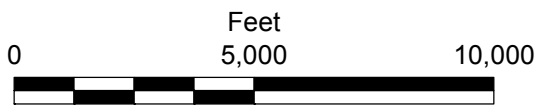
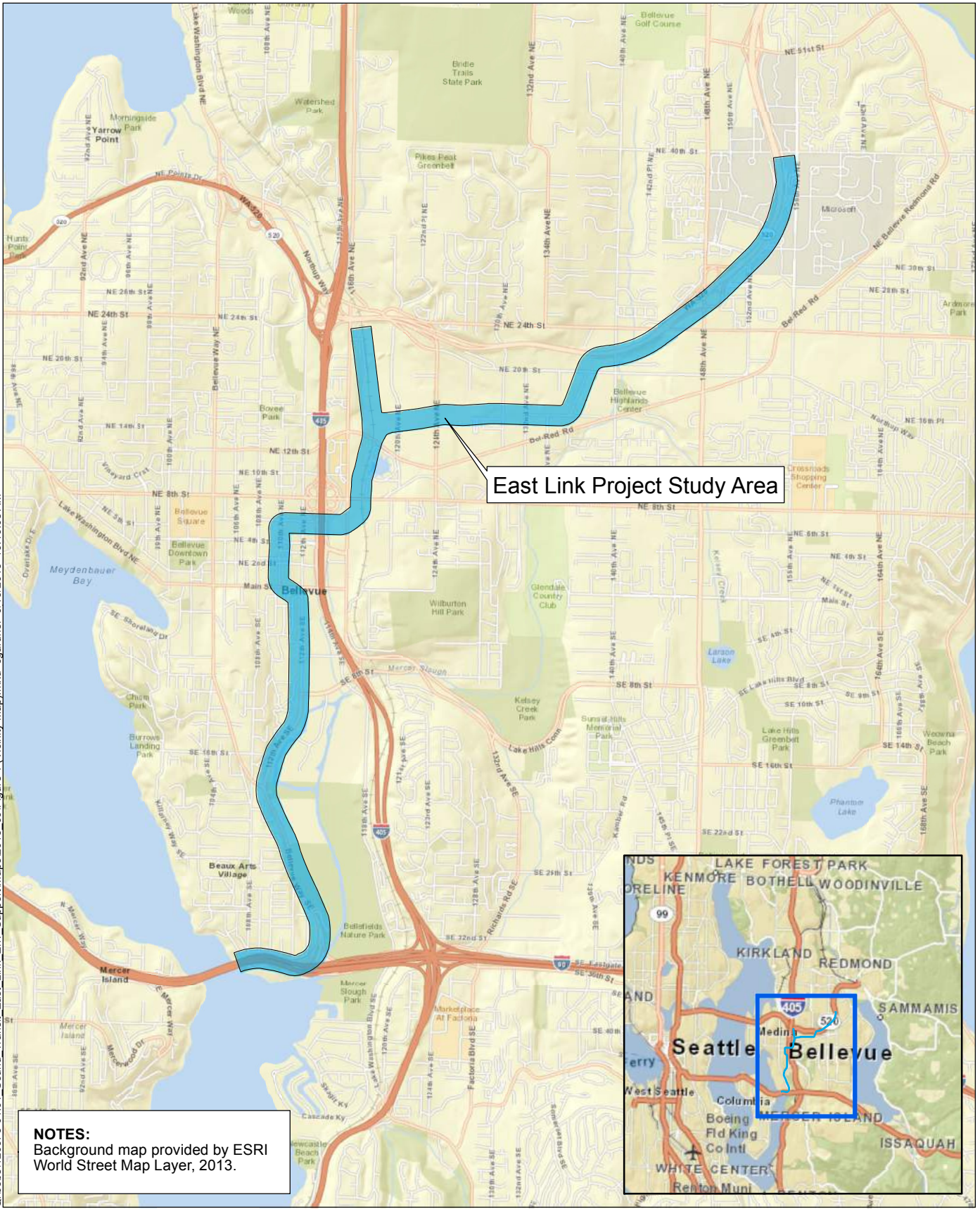

Figure 1
Vicinity Map
Wetlands, Stream Ordinary High Water Mark,
and Jurisdictional Ditch Delineation Report
Sound Transit East Link Extension Project

This report is intended to document and provide information on the presence of wetlands, streams, and jurisdictional ditches within the project area, as defined by local, state, and federal guidelines. The wetland, stream ordinary high water mark (OHWM), and jurisdictional ditch boundaries provided in this report document the existing conditions within the project area and are intended to provide information on the nature and location of regulated resources in the project area to support permitting and mitigation planning efforts for the proposed East Link Extension Project.

Twenty-one jurisdictional wetlands in the project area were delineated. Overall, wetlands and streams in the project area are generally degraded with a history of disturbance due to road or interchange construction and past development. Two wetlands are classified as Category IV, thirteen are Category III, and six are Category II wetlands, according to the Washington State Department of Ecology (Ecology) *Washington State Wetland Rating System for Western Washington: Revised* (Hruby 2004) and *Washington State Wetland Rating Form – Western Washington, Version 2* (Ecology 2008), and according to local wetland rating criteria, as defined in the Bellevue City Code (BCC) (Bellevue 2013a) and the Redmond Municipal Code (RMC) (Redmond 2013a). While the project area includes areas within the jurisdiction of the cities of Bellevue and Redmond, no wetlands, streams, or jurisdictional ditches were identified with the portion of the project area located within the City of Redmond. Therefore, only wetlands, streams, and jurisdictional ditches located within the City of Bellevue are discussed in this report.

The wetlands are further described based on the classification of the wetland vegetation. Emergent, scrub-shrub, and forested wetland vegetation classes (Cowardin et al. 1979) were found in the project area. Emergent wetlands are primarily dominated by Colonial bentgrass (*Agrostis capillaris*), field horsetail (*Equisetum arvense*), lady fern (*Athyrium filix-femina*), soft rush (*Juncus effusus*), and reed canarygrass (*Phalaris arundinacea*). Scrub-shrub and forested wetlands are characterized by species such as black cottonwood (*Populus balsamifera*), red alder (*Alnus rubra*), willow (*Salix* spp.), red-osier dogwood (*Cornus sericea*), salmonberry (*Rubus spectabilis*), spirea (*Spiraea douglasii*), and the nonnative species Himalayan blackberry (*Rubus armeniacus*). A variety of emergent, scrub-shrub, and forested systems, or a combination of these systems, are located in the project area. Aquatic bed habitat is only located in two wetlands in the project area.

Table 1 summarizes the wetland names, categories, buffer widths, and U.S. Fish and Wildlife Service (USFWS) classifications.

Table 1
Wetland Summary

Wetland Name	Wetland Category ¹	Buffer Width (feet)	USFWS Classification
Mercer Slough	II	110	PFO, PSS, PEM, PAB
Alcove Creek	II	75	PFO, PSS, PEM
Bellefield South	II	75	PFO, PSS, PEM
Bellefield North	II	75	PFO, PSS
8th Street	III	60	PFO, PSS, PEM
Lake Bellevue	III	60	PAB
South Lake	III	60	PFO, PSS, PEM
Central Lake	III	60	PSS, PEM
North Lake	IV	0	PFO, PEM
BNSF Southwest	III	60	PFO, PEM
BNSF East	III	60	PEM
BNSF West	III	60	PFO, PSS, PEM
BNSF Northeast	III	60	PFO, PSS
BNSF Northwest	IV	40	PFO, PEM
BNSF North	III	60	PFO, PSS
Kelsey West Tributary Pond	II	75	PFO, PEM
Kelsey West Tributary Stream	III	60	PFO, PSS, PEM
136th Place	III	60	PFO, PSS, PEM
SR 520 West	III	60	PFO, PSS, PEM
Valley Creek	II	75	PFO, PSS, PEM
SR 520 East	III	60	PFO, PSS, PEM

Notes:

All wetlands within the project area are located within the City of Bellevue

1 See Table 4 for descriptions of wetland categories.

PFO = palustrine forested

PSS = palustrine scrub-shrub

PEM = palustrine emergent

PAB = palustrine aquatic bed

SR = State Route

USFWS = U.S. Fish and Wildlife Service

The OHWM of ten stream systems within the project area were identified and delineated. The streams were classified according to local stream designation criteria (stream type for Bellevue, stream classification for Redmond), as defined in the BCC (Bellevue 2013a) and the RMC (Redmond 2013a). No stream functional data collection or analysis was completed for this report; however, a literature review of existing documentation on stream habitat and conditions was conducted, and information from this review is included as applicable in this report. Table 2 summarizes the stream names, stream ratings, and stream buffer widths based on the local rating.

Table 2
Stream Summary

Stream	Local Stream Rating ¹	Buffer Width (feet)
Stream A	Type N	50
Stream B	Type N	50
Wye Creek	Type F	100
Mercer Slough	Type S	100
Alcove Creek	Type F	50
Sturtevant Creek	Type F	50 ²
West Tributary to Kelsey Creek	Type F	50
Stream C	Type O	25
Goff Creek	Type F	50 ²
Unnamed Tributary to Kelsey Creek	Type N	50
Valley Creek	Type F	50 ²

Notes:

1 All streams identified during the investigation were located within the City of Bellevue jurisdiction.

2 These streams' buffers were applied based on guidance from Bellevue 2013a, Chapter 20.25H.075.C.1.a.

1.1 Organization of This Report

Descriptions of the proposed East Link Extension Project and project area are included in Section 2, which also includes a discussion of the purpose and goals of this report. The wetland delineation methods and results are described in Section 3. The stream OHWM delineation methods and results are described in Section 4. The jurisdictional ditch delineation methods and results are described in Section 5. A summary of data collected at

each sampling plot during the wetland delineation is presented in tables in Appendix A and in the field data forms in Appendix B. Ecology Wetland Rating Forms are included in Appendix C. Appendix D contains resource maps of delineated wetlands, streams, and jurisdictional ditches. Jurisdictional ditch field data forms are included in Appendix E.

2 INTRODUCTION

2.1 Purpose and Goals

This report has been prepared to provide information on the nature and location of regulated resources in the project area to support permitting and mitigation planning efforts for the proposed East Link Extension Project. Sensitive resources within the project area were delineated and classified, as described in this report. The objectives of this report are the following:

- Determine the location, condition, and local and state rating of wetlands, streams, and jurisdictional ditches within the project area
- Meet federal, state, and local regulations
- Support mitigation planning for the project

2.2 Project Description Summary and Background

The goal of the East Link Extension Project is to expand the Sound Transit Link light rail system from Seattle to Mercer Island, Bellevue, and Redmond via I-90 and to provide a reliable and efficient alternative for moving people throughout the region. The project corridor is located in King County, Washington, the most densely populated county in the Puget Sound region. The project travels eastward, crossing Lake Washington on the I-90 Floating Bridge. The project then crosses the East Channel Bridge from Mercer Island to the City of Bellevue. The project corridor extends north from I-90, between Bellevue Way and the I-405/former BNSF Railway corridor, to Downtown Bellevue. From Downtown Bellevue, the project corridor extends east, parallel to SR 520 through Bellevue's Bel-Red subarea and Overlake, a subarea in the City of Redmond. There are seven stations proposed for the project. Traveling west to east, these are the following:

1. An elevated station with associated parking structure at the South Bellevue Park and Ride,
2. The at-grade East Main station,
3. A tunnel station in downtown Bellevue near the current Bellevue Transit center,
4. An elevated station near the hospital just north of NE 8th Street,
5. A below-grade station at 120th Avenue NE,
6. An at-grade station at 130th Avenue NE, and a

7. Below-grade station at Overlake Village.

The construction footprint for light rail is smaller than a new location highway. The construction methods are similar, however. Staging areas are needed for construction as large pieces can be pre-assembled before being put in their final location. There is overhead power for the light rail cars, so there are no direct emissions from the operation of the light rail. There are traction power substations (TPSS) along the way placed every mile to mile and a half. These stations add power to the overhead power lines to keep voltage constant along the guideway. Elevated guideway is column supported on deep concrete column foundations or concrete spread footings depending on soil conditions. The at-grade sections of the guideway through Bellevue are mostly constructed on embedded track; track that is fully surrounded by concrete. Some sections will be constructed traditionally on railroad ballast; concrete ties are used in ballasted sections. There are a few sections that are constructed below-grade where walls may be found on one or both sides of the guideway.

The East Link project has received concurrence from the Federal Transit Administration, and the Federal Transportation Department through completion of an Environmental Impact Statement (EIS) and subsequent Record of Decision. In addition, the State Environmental Protection Act has also been completed. The City of Bellevue has concurred with the project alignment and major design elements through formal council action in April 2013. The project is now in the final design stage.

Overall, for a project this size, the alignment has small impacts to wetlands and streams. These are mostly limited to wetlands located adjacent to a prior wetland fill prism associated with the South Bellevue Park and Ride, some along Bellevue Way NE, and some at 112th Avenue SE. Other impacts include some minor, partial filling of low category wetlands near the hospital station and relocation of the ditch currently conveying Sturtevant Creek. Other minor impacts to isolated wetlands are also anticipated along the Bel-Red Corridor. All of these impacts add up to less than 1 acre of overall impact.

Sound Transit is evaluating several measures to compensate for impacted wetland and stream functions and values. Potential wetland and stream mitigation options include creation, restoration, and enhancement at both on- and off-site locations. To compensate for the

reduction of water quantity and water quality functions provided by the impacted wetlands, Sound Transit will also implement drainage system improvements to provide stormwater treatment and detention within each drainage basin. A detailed description of the project impacts, avoidance and minimization efforts, and proposed mitigation measures can be found in the Critical Areas Report relating to the East Link Extension Project (Anchor QEA and H-J-H 2014).

The East Link Extension Project would provide greater capacity and reliability, as well as improving travel time for people traveling between Seattle, Bellevue, and Redmond. To meet planned growth in the corridor, Bellevue, Seattle, and Redmond have made land use and planning decisions based upon increased employment and residential density, which would be more fully realized with the long-term promise of a high-capacity transit (HCT) connection across I-90. East Link Extension is this connection. Specifically, the project would:

- Improve speed and reliability and expand the region's transportation system capacity through an exclusive light rail transit right-of-way, while avoiding and minimizing impacts to the environment, where practicable.
- Meet growing transit and mobility demands by more than doubling person-moving capacity across Lake Washington on I-90.
- Increase mobility and accessibility to and from the region's highest employment and housing concentrations.
- Substantially reduce travel time for most transit riders.
- Continue to implement the goals and objectives identified in Sound Transit's Long-Range Plan, which guides the development of the regional HCT system.

2.3 Project Area Description

The East Link Extension Project is located within lowland areas adjacent to Lake Washington. Beginning at the western end of the project area and moving east, the project area extends from within the Bellevue city limits and into Redmond (Figure 1). The project area includes property under a variety of ownerships, including Washington State Department of Transportation, City of Bellevue, and City of Redmond parcels and right-of-ways, and parcels under private commercial or residential ownership. By the end of the

project, all property that is used for the project will either be owned by Sound Transit or have an easement(s) from local or state governments, or private property owners. For this analysis, the project area includes areas where temporary or permanent effects from the East Link Extension Project may occur. Due to the variety of property ownerships, right-of-entry (ROE) was not granted over the entire project area. All wetlands, streams, and jurisdictional ditches within the project area where ROE was granted were delineated and classified, as described in this report. In cases where property ROE was not granted, information on potential resources was identified and described based on visual observations from off-site. In these cases, property access will be necessary to confirm the presence, classification, and size of sensitive resources.

3 WETLANDS

In February, March, April, and May 2013, a delineation and rating analysis of wetland habitat in the project area was performed. Twenty-one wetlands were identified within the project area (Appendix D). Wetland delineation methods are presented in Section 3.1. A complete description of wetlands identified within the project area is provided in Section 3.2. A summary of data collected at each sampling plot during the wetland delineation is presented in tables in Appendix A and in the field data forms in Appendix B. Ecology Wetland Rating Forms are included in Appendix C. Wetland delineation results are shown on the figures provided in Appendix D.

3.1 Wetland Delineation Methods

This section describes the methodology used to perform the wetland delineation, including the review of existing information and field investigation procedures. These methods are consistent with current federal and state agency requirements, as well as local jurisdiction requirements for performing wetland delineations and identifying protective wetland buffer widths.

As specified by the BCC (Bellevue 2013a) and the RMC (Redmond 2013a), this wetland delineation was conducted according to the methods defined in the *U.S. Army Corps of Engineers Wetland Delineation Manual* (Environmental Laboratory 1987), the *Regional Supplement to the Corps of Engineers Wetland Delineation Manual: Western Mountains, Valleys, and Coast Region* (Corps 2010), and Ecology's *Washington State Wetland Identification and Delineation Manual* (Ecology 1997). The U.S. Army Corps of Engineers (Corps; Environmental Laboratory 1987), the *Washington State Shoreline Management Act* (Ecology 2009), the *Washington State Growth Management Act* (Access Washington 2009), the BCC (Bellevue 2013a), and the RMC (Redmond 2013a) all define wetlands as, "those areas that are inundated or saturated by surface or groundwater at a frequency and duration sufficient to support, and that under normal circumstances do support, a prevalence of vegetation typically adapted for life in saturated soil conditions. Wetlands generally include swamps, marshes, bogs, and similar areas."

The method for delineating wetlands is based on the presence of three parameters: hydrophytic vegetation, hydric soils, and surface/groundwater hydrology. Hydrophytic vegetation is “the macrophytic plant life that occurs in areas where the frequency and duration of inundation or soil saturation produce permanently or periodically saturated soils of sufficient duration to exert a controlling influence on the plant species present.” Hydric soils are “formed under conditions of saturation, flooding, or ponding long enough during the growing season to develop anaerobic conditions in the upper part.” Wetland hydrology “encompasses all hydrologic characteristics of areas that are periodically inundated or have soils saturated to the surface for a sufficient duration during the growing season” (Environmental Laboratory 1987). Data collection methods for each of these parameters are described in the following sections.

As shown on the wetland rating forms, data plots within the project area were established, and information on hydrology, soils, and vegetation was recorded. Sample plots are identified by the associated wetland and as wetland or upland plots (e.g., MS SP1-W for a Mercer Slough wetland sample, and MS SP2-U for a Mercer Slough upland sample). Vegetation, soils, and hydrology information was collected at each of the plots and recorded on field data sheets. A summary of sample plot data is presented in Appendix A. The field data forms are provided in Appendix B.

At the request of Sound Transit (Louther 2013), sample plot data was collected at four locations in the project area where only wetland vegetation was present. Although these areas may appear to meet wetland criteria, the purpose of the sample plots is to document that they do not meet wetland conditions. While none of these areas were found to demonstrate wetland conditions, a brief discussion of these areas is included within the description of wetlands in their immediate vicinity; a summary of data collected at each of these four locations is presented in tables in Appendix A, field data forms for these four locations are provided in Appendix B, and their locations are noted on project maps (Appendix D).

Wetland boundaries were determined based upon plot data and visual observations of each wetland. Each wetland boundary was flagged and subsequently surveyed by a professional surveyor to establish and verify the wetland’s size and location. In cases where ROE

conditions stipulated that survey flags not be used, wetland boundary data was collected with a global positioning system (GPS) unit. In some cases, wetland boundaries extended beyond the limits of the right-of-way and/or approved ROE. In those cases, wetland vegetation and hydrology outside of the project area were noted from visual observations. The total extent/area of the wetland(s) was approximated from existing documentation, topography, and/or available aerial imagery.

3.1.1 Vegetation

Plant species occurring in each plot were recorded on field data forms, with one data form per plot (Appendix B). Percent cover in the plot was estimated for each plant species, and dominant plant species were identified. At each plot, aerial vegetative growth of trees was identified and recorded within a 30-foot radius, shrubs within a 15-foot radius, and emergent vegetation within a 3-foot radius from the center of the plot. A plant indicator status designated by the USFWS (Corps 2013) was assigned to each species, and a determination was made as to whether the vegetation in the plot was hydrophytic. To meet the hydrophytic parameter, more than 50 percent of the dominant species, with 20 percent or greater cover, must have an indicator of obligate wetland, facultative wetland, or facultative. Table 3 shows the wetland indicator status categories and definitions.

**Table 3
Wetland Plant Indicator Definitions**

Indicator Status	Description
Obligate wetland (OBL)	Plant species almost always occur in wetlands (estimated probability greater than 99%) under natural conditions.
Facultative wetland (FACW)	Plant species usually occur in wetlands (estimated probability 67% to 99%), but occasionally found in non-wetlands.
Facultative (FAC)	Plant species equally likely to occur in wetlands or non-wetlands (estimated probability 34% to 66%).
Facultative upland (FACU)	Plant species usually occur in non-wetlands (estimated probability 67% to 99%), but occasionally found in wetlands.
Obligate upland (UPL)	Plant species occur almost always in non-wetlands (estimated probability greater than 99%) under natural conditions.

3.1.2 Soils

Soils in each plot were sampled and evaluated for hydric soil indicators. Soil pits were dug to a depth of 16 inches or greater. Anchor QEA classified soil colors by their numerical description, as identified on the *Munsell Soil Color Charts* (Munsell 1994). Hydric soil indicators include low soil matrix chroma, gleying, and redoximorphic (redox) features. Redox features are spots of contrasting color occurring within the soil matrix (the predominant soil color). Gleyed soils are predominantly bluish, greenish, or grayish in color. Soils having a chroma of 2 (with redox features) or less (with or without redox features) are positive indicators of hydric soils (Environmental Laboratory 1987; Corps 2010).

3.1.3 Hydrology

Wetland hydrology was evaluated at each plot to determine whether it “encompasses all hydrologic characteristics of areas that are periodically inundated or have soils saturated to the surface for a sufficient duration during the growing season” (Ecology 1997). The mesic (i.e., wet) growing season in Western Washington is generally March through October. Field observations were recorded in the field data forms (Appendix B) of saturation, inundation, and other indicators of wetland hydrology, such as water-stained leaves and drainage patterns in potential wetlands.

3.1.4 Wetland Classifications

Wetland community types are discussed in this report according to the USFWS classification developed by Cowardin et al. (1979) for use in the National Wetlands Inventory (NWI). This system, published in 1979 by a team of USFWS scientists led by L.M. Cowardin, bases the classification of wetlands on their physical characteristics such as the general type of vegetation in the wetland (e.g., trees, shrubs, grass) and where and how much water is present in the wetland. The Cowardin system provides a classification for every known wetland type that occurs throughout the United States, and under this system, a wetland can be classified as having one or more wetland classification types. The following community types were found during this investigation:

- Palustrine forested (PFO) – These wetlands have at least 30 percent cover of woody vegetation that is more than 20 feet high.

- Palustrine scrub-shrub (PSS) – These wetlands have at least 30 percent cover of woody vegetation that is less than 20 feet high.
- Palustrine emergent (PEM) – These wetlands have erect, rooted, herbaceous vegetation present for most of the growing season in most years.
- Palustrine aquatic bed (PAB) – These wetlands are dominated by vegetation that grows principally on or below the surface of the water for most of the growing season in most years.

3.1.5 State Wetland Rating System

At the state level, wetland ratings were determined using the most current version of Ecology guidance in *Washington State Wetlands Rating System for Western Washington: Revised* (Hruby 2004) and *Washington State Wetland Rating Form – Western Washington, Version 2* (Ecology 2008).

This system, developed by Ecology, is used to differentiate wetlands based on their sensitivity to disturbance, their significance in the watershed, their rarity, our ability to replace them, and the beneficial functions they provide to society. The Ecology rating system requires the user to collect specific information about the wetland in a step-by-step process. Three major functions are analyzed: water quality improvement, flood and erosion control, and wildlife habitat. Ratings are based on a point system, where points are given if a wetland meets specific criteria related to the wetland's potential and the opportunity to provide certain benefits.

Per Ecology's rating system, wetlands are categorized according to the following criteria and to points given:

- Category I wetlands (70 to 100 points) represent a unique or rare wetland type, are more sensitive to disturbance, or are relatively undisturbed and contain ecological attributes that are impossible to replace within a human lifetime.
- Category II wetlands (51 to 69 points) are difficult, though not impossible, to replace, and provide high levels of some functions.

- Category III (30 to 50 points) wetlands have moderate levels of functions. They have been disturbed in some ways and are often less diverse or more isolated from other natural resources in the landscape than Category II wetlands.
- Category IV wetlands (0 to 29 points) have the lowest levels of functions and are often heavily disturbed.

3.1.6 State Hydrogeomorphic Classification System

Scientists have come to understand that wetlands can perform functions in different ways. The way that wetlands function depends to a large degree on hydrologic and geomorphic conditions. Because of these differences among wetlands, a new way to group or classify them has been developed. This classification system, called the Hydrogeomorphic (HGM) Classification, groups wetlands into categories based on the geomorphic and hydrologic characteristics that control many functions. This revision to the Washington State Wetland Rating Form – Western Washington, Version 2 (Ecology 2008) incorporates the new system as part of the questionnaire for characterizing a wetland’s functions. The rating system uses only the highest grouping in the classification (i.e., wetland class). Wetland classes are based on geomorphic settings, such as riverine or depressional. A classification key is provided within the rating form to help identify which of the following HGM Classifications apply to the wetland: riverine, depressional, slope, lake-fringe, tidal fringe, or flats.

3.1.7 Local Jurisdictions’ Wetland Rating Systems and Buffer Requirements

Wetlands in the project area were rated according to the local jurisdiction’s critical areas ordinances that establish local regulatory requirements for wetlands and their associated buffers. All 21 of the wetlands identified during the investigation are located within the City of Bellevue, and no wetlands were identified within the City of Redmond. Since no wetlands were identified within the City of Redmond, no additional information on Redmond’s regulations of wetlands and associated buffers is included in this report. A local rating category was assigned to wetlands in the project area, and associated wetland buffer widths were identified based on the applicable city code regulations.

The following section extracts wetland information contained in the BCC (Bellevue 2013a). The full text of Bellevue’s critical areas regulations was consulted during the analysis.

3.1.7.1 City of Bellevue

The BCC classifies wetlands into four categories (Categories I, II, III, and IV) based on Ecology’s *Washington State Wetland Rating System for Western Washington: Revised* (Hruby 2004). According to the BCC, wetland buffers shall be established from the wetland edge, as summarized in Table 4.

Table 4
City of Bellevue Wetland and Wetland Buffer Regulations

Wetland Category	Wetland Characteristics ¹	Buffer Width (feet)
Category I	Natural heritage wetlands	190
	Bogs	190
	Forested	Based on score for habitat or water quality functions
	Habitat score of 29 to 36	225
	Habitat score of 20 to 28	110
	Water quality score of 24 to 32 and habitat score of less than 20	75
	Not meeting any of the above	75
Category II	Habitat score of 29 to 36	225
	Habitat score of 20 to 28	110
	Water quality score of 24 to 32 and habitat score of less than 20	75
	Not meeting any of the above	75
Category III	Habitat score of 20 to 28 points	110
	Not meeting any of the above	60
Category IV (more than 2,500 square feet)	Score for functions less than 30 points	40

Notes:

Source: Bellevue 2013a, Chapter 20.25H.095.C.1.a

1 Habitat and water quality scores per Hruby 2004 and Ecology 2008.

3.1.8 Wetland Functions Assessment

The functional values of wetlands were rated according to *Washington State Wetland Rating System for Western Washington: Revised* (Hruby 2004) and *Washington State Wetland Rating Form – Western Washington, Version 2* (Ecology 2008). Using Ecology’s system, wetlands were rated based on a point system, where points are awarded to three functional value categories: water quality, hydrologic, and wildlife habitat. To determine an accurate assessment of a wetland’s functional values, function scores were calculated based on entire

wetland systems, when applicable, not just the delineated portion of wetlands. Detailed scoring for each delineated wetland, based on Ecology wetland rating forms, is provided in Appendix C. Project wetland rating scores are discussed in Section 3.3.

3.1.9 Review of Existing Information

As part of the analysis to identify natural resources and critical areas in the project area, the following sources of information to support field observations were reviewed:

- *Natural Resource Conservation Service (NRCS) Web Soil Survey* (USDA 2013a)
- *Hydric Soil List for Washington State* (USDA 2013b)
- *USFWS Wetlands Mapper for National Wetlands Inventory (NWI) Map Information* (USFWS 2013)
- Washington Department of Fish and Wildlife (WDFW) Priority Habitats and Species Maps (WDFW 2013a)
- WDFW SalmonScape Interactive mapper (2013b)
- BCC (Bellevue 2013a)
- Bellevue Critical Areas Maps (Bellevue 2013b)
- RMC (Redmond 2013a)
- Redmond Critical Areas Maps (Redmond 2013b)
- *East Link Light Rail Project Final Environmental Impact Statement* and technical appendices (Sound Transit 2011)
- Google Earth aerial imagery (February to April 2013)

3.2 Wetland Determination

Twenty-one wetlands were identified within the project area, as defined in Section 2.3. The project area spans a cumulative length of 7.13 miles (Figure 1) and contains nine drainage basins within the Cedar/Sammamish Watershed (Water Resource Inventory Area 8 [WRIA 8]) (Ecology 2013). The nine basins, in order from west to east along the project alignment, include Beaux Arts, Mercer Slough, Sturtevant Creek, West Tributary, Goff Creek, Kelsey Creek, Valley Creek, Sears Creek, and Lake Sammamish (Bellevue 2013b; Redmond 2013b). The first seven basins are located within Bellevue. The eighth basin, Sears Creek, is located within the city limits of both Bellevue and Redmond. The ninth basin, Lake Sammamish, is located within the city limits of Redmond. Drainage basins are shown on Figure 2. NRCS

soil map data for the project area are presented in Figure 3. Wetland delineation results are shown on the figures in Appendix D. The wetland areas on the figures include the total area of wetland delineated within the project area and the estimated wetland area outside the project area, based on visual observations from within the project area, aerial photograph analysis, and the location of development features that would limit the extent of the wetland systems. Table 5 presents a summary of the wetlands in the project area, including the approximate wetland size and drainage basin.

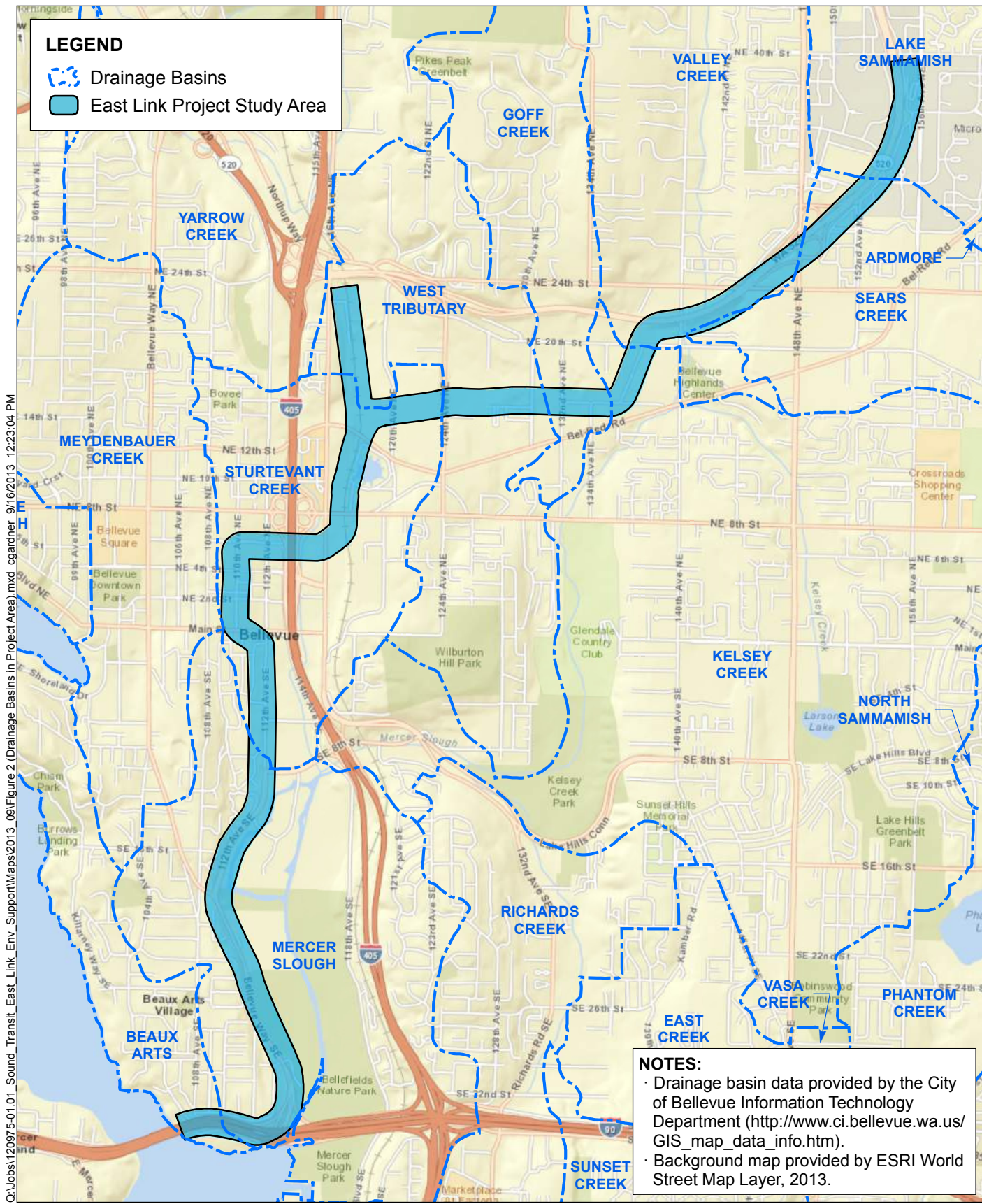

LEGEND

- Drainage Basins
- East Link Project Study Area

NOTES:

- Drainage basin data provided by the City of Bellevue Information Technology Department (http://www.ci.bellevue.wa.us/GIS_map_data_info.htm).
- Background map provided by ESRI World Street Map Layer, 2013.

C:\Jobs\120975-01.01_Sound_Transit_East_Link_Env_Support\Maps\2013_09\Figure 2 (Drainage Basins in Project Area).mxd cgardner 9/16/2013 12:23:04 PM

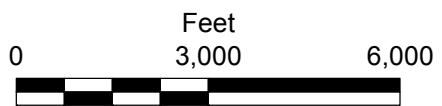
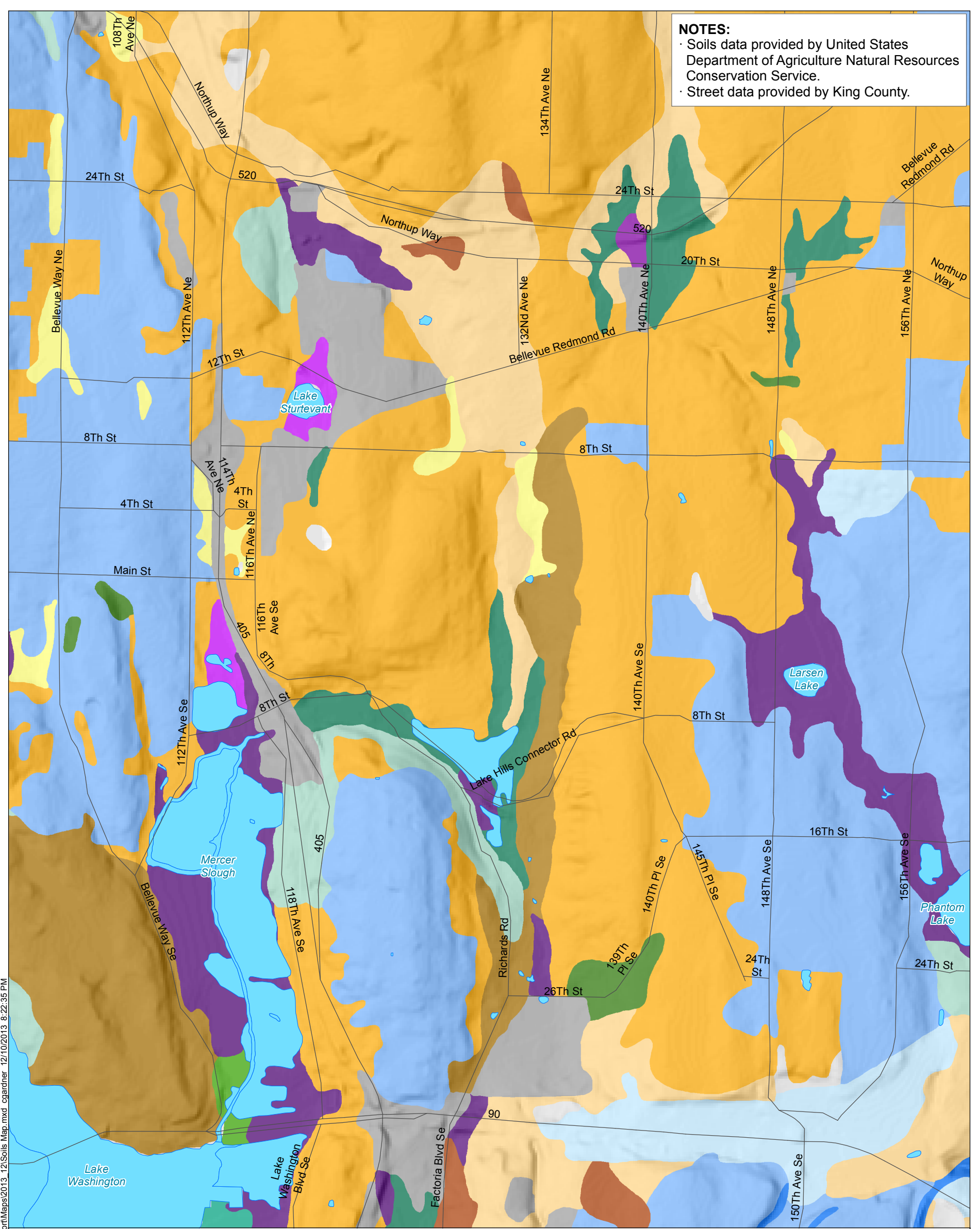

Figure 2
 Drainage Basins in Project Area
 Wetlands, Stream Ordinary High Water Mark,
 and Jurisdictional Ditch Delineation Report
 Sound Transit East Link Extension Project

NOTES:
 · Soils data provided by United States Department of Agriculture Natural Resources Conservation Service.
 · Street data provided by King County.



C:\AQ_GIS\Jobs\120975-01.01_Sound_Transit_East_Link_Env_Support\Maps\2013_12\Soils_Map.mxd cgardner 12/10/2013 8:22:35 PM

NRCS Soils

- Alderwood and Kitsap soils, very steep
- Arents, Alderwood material
- Arents, Everett material
- Everett-Alderwood gravelly sandy loams
- Beausite gravelly sandy loam
- Alderwood gravelly sandy loam
- Everett gravelly sandy loam

- Bellingham silt loam
- Briscot silt loam
- Buckley silt loam
- Kitsap silt loam
- Mixed alluvial sand
- Norma sandy loam
- Indianola loamy fine sand
- Pilchuck loamy fine sand

- Ovall gravelly loam
- Ragnar-Indianola association
- Snohomish silt loam
- Seattle muck
- Shalcar muck
- Tukwila muck
- Urban land
- Pits

- Water Bodies
- Major Roads

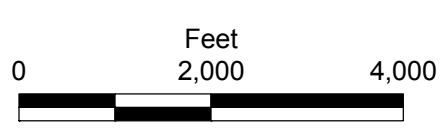

Figure 3
 NRCS Soil Map Data
 Sound Transit East Link
 Extension Project

**Table 5
Summary of Wetlands Located within the Project Area**

Wetland	Size (acres)¹	Field Flagging Numbers	Flagging Description	Drainage Basin²
Mercer Slough	350 ²	245 total (WF A01 to A123, WF A47A to A47T, and WF Z1 to Z102)	Blue/white striped flagging	Mercer Slough
Alcove Creek	0.23 ³ / 0.6 ²	24 total (WF I01 to I24)	Blue/white striped flagging	Mercer Slough
Bellefield South	0.29	19 total (flags hung but removed due to ROE agreement)	No flagging left post survey	Mercer Slough
Bellefield North	0.11	10 total (flags hung but removed due to ROE agreement)	No flagging left post survey	Mercer Slough
8th Street	0.05 ³ / 0.1 ²	20 total (WF 01 to 15 and WF 16 to 20)	Orange pin flags	Mercer Slough
Lake Bellevue	0.54 ³ / 7.00 ²	28 total (LB 16 to 23 and RB 16 to 35)	Blue/white striped flagging	Sturtevant Creek
South Lake	0.09	18 total (WF C01 to C18)	Blue/white striped flagging	Sturtevant Creek
Central Lake	0.03	5 total (WF D01 to D5)	Blue/white striped flagging	Sturtevant Creek
North Lake	0.04	6 total (WF E01 to E6)	Blue/white striped flagging	Sturtevant Creek
BNSF Southwest	0.12	12 total (WF G01 to E12)	Blue/white striped flagging	West Tributary
BNSF East	0.06 ⁴ / 0.1 ³	14 total (7 paired sets)	Blue/white striped flagging	West Tributary
BNSF West	0.63 ³ / 0.8 ²	48 total (WF H01 to H48)	Blue/white striped flagging	West Tributary
BNSF Northeast	0.02	7 total (WF M01 to M7)	Blue/white striped flagging	West Tributary
BNSF Northwest	0.06	8 total (WF L01 to L8)	Blue/white striped flagging	West Tributary
BNSF North	0.02	11 total (WF N01 to N11)	Blue/white striped flagging	West Tributary
Kelsey West Tributary Pond	5.98 ⁵	Field verified past delineation	No flagging	West Tributary
Kelsey West Tributary Stream	0.04	10 total (WF RB01 to RB05 and WF LB01 to LB05)	Blue/white striped flagging	West Tributary
136th Place	0.03	10 total (WF K01 to K10)	Blue/white striped flagging	Kelsey Creek
SR 520 West	0.51 ³ / 0.6 ²	54 total (WR11-01 to WR11-54)	Blue/white striped flagging	Valley Creek
Valley Creek	0.37 ⁵	Field verified past delineation	No flagging	Valley Creek
SR 520 East	0.23	Field verified past delineation with 13 new flags added (WF O01 to O13)	Blue/white striped flagging	Valley Creek

Notes:

- 1 When only one number is present, total wetland area is located within the Project area. When two numbers are present, the wetland extends outside the Project area, and both the estimated total area (superscript 2) and the delineated area (superscript 3) are provided. Estimates for wetlands outside the project area are based on observations during the field investigation and aerial photograph analysis. Wetland acreages within project area were provided by HJH.
- 2 Approximate total wetland area, includes delineated area plus estimated wetland area extending outside project area
- 3 Delineated wetland area within project area
- 4 Bellevue 2013b; Redmond 2013b
- 5 Information based on 2011 delineation (Parametrix 2012)

3.3 Wetland Descriptions

The 21 wetlands in the project area are described in the following sections, and wetland descriptions are grouped into one of the following nine drainage basins, depending on wetland location: Beaux Arts, Mercer Slough, Sturtevant Creek, West Tributary, Goff Creek, Kelsey Creek, Valley Creek, Sears Creek, and Lake Sammamish basins (Figure 2). Since no wetlands were identified within four of the basins (Beaux Arts, Goff Creek, Sears Creek, and Lake Sammamish), these basins are not included in the following sections.

Within each drainage basin, wetlands were described in location sequence from west to east. The following wetland description sections describe the characteristics of land use adjacent to wetlands in the project area, which typically include jurisdictional wetland buffers and existing adjacent structures or other developments. For this analysis, wetland buffers are vegetated areas, which are protected under local and state regulations, requiring compensatory mitigation when they are disturbed. Existing adjacent structures, such as buildings, road prisms, and paved or impervious surfaces, do not require compensatory mitigation for disturbance under local and state regulations, but provide information on the overall functions and values of the wetland systems. Most of the wetlands in the project area are adjacent to paved surfaces, buildings, or other structures. Since regulated wetland buffers end at the edge of vegetated areas and do not include paved surfaces or other developed features, only vegetated areas were used to calculate the wetland buffer area of wetlands in the project area.

3.3.1 Mercer Slough Basin

Five wetlands were identified within the Mercer Slough basin within the project area: four Category II wetlands, Mercer Slough Wetland, Alcove Creek Wetland, Bellefield South Wetland, and Bellefield North Wetland; and one Category III wetland, 8th Street Wetland. Within this basin, the project area generally extends from I-90 and about 110th Avenue SE to about 112th Avenue SE and SE 8th Street (Figure 2). All five of the wetlands are located near or adjacent to roads or commercial or residential development and receive water from surface water drainage or culverts. The Mercer Slough Wetland is associated with Mercer Slough and streams A and B. Bellefield South and Bellefield North wetlands are adjacent to an excavated open water area within the Mercer Slough wetland. The Alcove Creek

Wetland is associated with Alcove Creek. Wetlands in the Mercer Slough basin are summarized on Table 5 and shown on the figures in Appendix D, Frames 2, 3, 4, and 5.

3.3.1.1 Mercer Slough Wetland

- *Size and location:* Mercer Slough Wetland is a large wetland system associated with Mercer Slough and Lake Washington. Portions of the Mercer Slough Wetland were delineated within the project area. For this investigation, only the western boundary of the wetland associated with the proposed project alignment was delineated. The delineated boundary of the wetland is located adjacent to Bellevue Way SE and 112th Avenue SE (Appendix D, Frames 2, 3, and 4). Based on aerial photograph analysis and City of Bellevue critical areas maps (Bellevue 2013b), the Mercer Slough Wetland complex is approximately 350 acres or greater in size. Mercer Slough Wetland is also associated with streams A and B (Section 4.2). Ten sample plots were established during the delineation of Mercer Slough Wetland (Appendices A and B). The wetland is identified on City of Bellevue critical areas maps (Bellevue 2013b). This wetland is also subject to regulation under the City of Bellevue Shoreline Master Program (BCC 20.25E) as an associated wetland.
- *Vegetation:* Due to the large size of Mercer Slough Wetland, a variety of vegetation species are present within this wetland. Dominant vegetation includes red alder, black cottonwood, western red cedar (*Thuja plicata*), Pacific willow (*Salix lasiandra*), red-osier dogwood, twinberry (*Lonicera involucrata*), spirea, creeping buttercup (*Ranunculus repens*), reed canarygrass, lady fern, and salmonberry (Appendices A and B). Ten data plots were collected for this large wetland system.
- *Soils:* Wetland soils ranged from black (10YR 2/1), to very dark brown (10YR 2/2), to very dark gray (10YR 3/1), to dark gray (10YR 4/1). Wetland soil textures ranged from silt, to silt loam, to clay loam, to sandy loam (Appendices A and B).
- *Hydrology:* Soils were typically saturated to the surface in the soil data pits. The water table was encountered at a depth ranging from the surface to a depth greater than 18 inches (Appendices A and B). The wetland is associated with Mercer Slough, Lake Washington, and streams A and B (Section 4.2).
- *Wetland classification:* Mercer Slough Wetland is a large wetland with PFO, PSS, PEM, and PAB vegetation classes and depressional, lake-fringe, riverine, and slope

HGM classes. The wetland soils are saturated, seasonally inundated, and riverine and lake-fringe associated. Mercer Slough Wetland is a Category II wetland under Ecology's rating system and the City of Bellevue's critical areas regulations (110-foot buffer).

- *Wetland function scores:* Mercer Slough Wetland scores a moderate potential to improve water quality and provide opportunities to improve water quality (20 out of 32 possible maximum score). The wetland scores a moderate potential to reduce flooding and erosion and does not provide the opportunity to reduce flooding and erosion (10 out of 32 possible maximum score). This wetland does not provide the opportunity to reduce flooding and erosion because water levels in Lake Washington are controlled by the Corps at the Ballard Locks. The wetland scores a high potential and moderate opportunity (27 out of 36 possible maximum score) to provide habitat functions. Overall, the total Ecology wetland functions score for Mercer Slough Wetland is 57 out of a possible 100.
- *Wetland adjacent land use:* Upland areas adjacent to the wetland are dominated by fill, paved areas, and buildings associated with roads and commercial development to the east, west, and north. Adjacent roads include I-90 and associated on- and off-ramps, Bellevue Way SE, and 12th Avenue SE. Lake Washington is located to the south.
- *Wetland determination:* The jurisdictional boundary of Mercer Slough Wetland was delineated and mapped in the vicinity of the project area in February 2013. The boundary of Mercer Slough Wetland within the project area was delineated with 245 flags. Mercer Slough Wetland was identified as Wetland WR-1/2 Mercer Slough Wetland in the *East Link Light Rail Project Final Environmental Impact Statement* (Sound Transit 2011).

3.3.1.2 *Alcove Creek Wetland*

- *Size and location:* Alcove Creek Wetland is located in an area between residential development at SE 15th Street and 112th Avenue SE (Appendix D, Frame 5). The wetland extends outside the project area to the west and ROE was not provided to identify the entire wetland boundary. A 0.23-acre portion of the Alcove Creek Wetland was delineated within the project area. Based on visual observations from

within the project area, aerial photograph analysis, and the location of development features that would limit the extent of the wetland system, the total size of the Alcove Creek Wetland is estimated at 0.6 acre, provided that the two associated residential pond features meet the criteria of wetland habitat. The Alcove Creek Wetland is associated with Alcove Creek (Section 4.2). Two sample plots were established during the delineation of Alcove Creek Wetland (Appendices A and B). A portion of the wetland is identified on City of Bellevue critical areas maps (Bellevue 2013b).

- *Vegetation:* Dominant vegetation includes red alder, Oregon ash (*Fraxinus latifolia*), black cottonwood, Pacific willow, red-osier dogwood, lady fern, and skunk cabbage (*Lysichiton americanus*) (Appendices A and B).
- *Soils:* Soils are typically very dark gray (10YR 3/1) silt loam to below 18 inches deep (Appendices A and B).
- *Hydrology:* Soils are saturated to the surface in the soil data pit, with the water table present about 5 inches from the surface (Appendices A and B). The wetland is associated with two man-made ponded areas within the residential development and an unnamed stream, identified as Alcove Creek (Section 4.2), flows from the pond through part of the wetland system before flowing through a culvert beneath 12th Avenue SE. The wetland receives artificial hydrology via pumped and piped water from Mercer Slough. The electric pump keeps the ponds flowing with water.
- *Wetland classification:* Alcove Creek Wetland is a small wetland with PFO, PSS, and PEM vegetation classes and depressional and riverine HGM classes. The wetland soils are saturated, seasonally inundated, and riverine associated. It is a Category II wetland under Ecology's rating system and the City of Bellevue's critical areas regulations (75-foot buffer).
- *Wetland function scores:* Alcove Creek Wetland scores a moderate potential to improve water quality and provide opportunities to improve water quality (14 out of 32 possible maximum score). The wetland scores a moderate potential to reduce flooding and erosion and provides the opportunity to reduce flooding and erosion (20 out of 32 possible maximum score). The wetland scores a high potential and moderate opportunity (19 out of 36 possible maximum score) to provide habitat functions. Overall, the total Ecology wetland functions score for Alcove Creek Wetland is 53 out of a possible 100.
- *Wetland adjacent land use:* Upland areas adjacent to the wetland are dominated by fill

associated with 12th Avenue SE and pavement and buildings associated with residential development.

- *Wetland determination:* In April 2013, Alcove Creek Wetland was delineated and mapped based on topography and the corresponding fill associated with the adjacent roads and development, upland soils, and lack of hydrologic indicators. The boundary of Alcove Creek Wetland within the project area was delineated with 24 flags.

3.3.1.3 Bellefield South Wetland

- *Size and location:* Bellefield South Wetland is located northeast of 112th Avenue SE 15th Street. Bellefield North Wetland is located north of the wetland (Appendix D, Frame 5). The entire wetland boundary was delineated, approximately 0.29 acre within the project area. Bellefield South Wetland is associated with Mercer Slough (Section 4.2). Two sample plots were established during the delineation of Bellefield South Wetland (Appendices A and B). This wetland is also subject to regulation under the City of Bellevue Shoreline Master Program (BCC 20.25E) as an associated wetland.
- *Vegetation:* Dominant vegetation includes Oregon ash, red alder, Pacific willow, Himalayan blackberry, and stinging nettle (*Urtica dioica*) (Appendices A and B).
- *Soils:* Soils are typically black (10YR 2/1) loam with coarse organic material to about 14 inches deep. Pieces of charcoal and brick were frequently observed within the soil profile, indicating past land use activities at the site (Appendices A and B).
- *Hydrology:* Soils were saturated to the surface in the soil data pit, with no water table present to a depth of 18 inches from the surface (Appendices A and B). The wetland is associated with the shoreline of Mercer Slough (Section 4.2); however, the wetland is located upslope of the slough, and the source of hydrology within the wetland is dominated by seeps and groundwater sources as opposed to water from the slough extending above the OHWM into the wetland.
- *Wetland classification:* Bellefield South Wetland is a small wetland with PFO, PSS, and PEM vegetation classes and riverine and slope HGM classes. The wetland soils are saturated and seasonally inundated and riverine associated. Bellefield South Wetland is a Category II wetland under Ecology's rating system and the City of Bellevue's critical areas regulations (75-foot buffer).

- *Wetland function scores:* Bellefield South Wetland scores a moderate potential to improve water quality and provide opportunities to improve water quality (20 out of 32 possible maximum score). The wetland scores a moderate potential to reduce flooding and erosion and provides the opportunity to reduce flooding and erosion (16 out of 32 possible maximum score). Bellefield South Wetland provides the opportunity to reduce flooding and erosion, while the Mercer Slough Wetland does not provide this opportunity, because there are building structures located downstream of the Bellefield South Wetland that can be damaged by flooding, and the Mercer Slough Wetland is located downstream of these structures. The wetland scores a moderate potential and moderate opportunity (18 out of 36 possible maximum score) to provide habitat functions. Overall, the total Ecology wetland functions score for Bellefield South Wetland is 54 out of a possible 100.
- *Wetland adjacent land use:* Upland areas adjacent to the wetland are dominated by fill associated with 12th Avenue SE and SE 15th Street. Mowed lawn is located between the roads and the wetland.
- *Wetland determination:* In May 2013, Bellefield South Wetland was delineated and mapped based on topography and the corresponding fill associated with the adjacent roads and development, upland vegetation and soils, and lack of hydrologic indicators. Nineteen GPS data points were used to delineate the boundary of Bellefield South Wetland within the project area.

3.3.1.4 *Bellefield North Wetland*

- *Size and location:* Bellefield North Wetland is located in an area between 112th Avenue SE and Mercer Slough. Bellefield South Wetland is located approximately 50 feet south of Bellefield North Wetland (Appendix D, Frame 5). The entire wetland boundary was delineated, approximately 0.11 acre within the project area. Bellefield North Wetland is associated with Mercer Slough (Section 4.2). Two sample plots were established during the delineation of Bellefield North Wetland (Appendices A and B). This wetland is also subject to regulation under the City of Bellevue Shoreline Master Program (BCC 20.25E) as an associated wetland.

- *Vegetation:* Dominant vegetation includes Oregon ash, black cottonwood, red alder, Pacific willow, prickly currant (*Ribes lacustre*), Himalayan blackberry, lady fern, and stinging nettle (Appendices A and B).
- *Soils:* Soils are typically black (10YR 2/1) loam to below 18 inches deep (Appendices A and B).
- *Hydrology:* Soils were saturated at about 6 inches from the surface in the soil data pit, with no water table present to a depth of 18 inches from the surface (Appendices A and B). The wetland is associated with the shoreline of Mercer Slough (Section 4.2); however, the wetland is located upslope of the slough, and the source of hydrology within the wetland is dominated by seeps and groundwater sources as opposed to water from the slough extending above the OHWM into the wetland.
- *Wetland classification:* Bellefield North Wetland is a small wetland with PFO and PSS vegetation classes and riverine and slope HGM classes. The wetland soils are saturated and seasonally inundated and riverine associated. Bellefield North Wetland is a Category II wetland under Ecology's rating system and the City of Bellevue's critical areas regulations (75-foot buffer).
- *Wetland function scores:* Bellefield North Wetland scores a moderate potential to improve water quality and provide opportunities to improve water quality (20 out of 32 possible maximum score). The wetland scores a moderate potential to reduce flooding and erosion and provides the opportunity to reduce flooding and erosion (16 out of 32 possible maximum score). Bellefield North Wetland provides the opportunity to reduce flooding and erosion, while the Mercer Slough Wetland does not provide this opportunity, because there are building structures located downstream of the Bellefield North Wetland that can be damaged by flooding, and the Mercer Slough Wetland is located downstream of these structures. The wetland scores a moderate potential and moderate opportunity (17 out of 36 possible maximum score) to provide habitat functions. Overall, the total Ecology wetland functions score for Bellefield North Wetland is 53 out of a possible 100.
- *Wetland adjacent land use:* Upland areas adjacent to the wetland are dominated by fill associated with 12th Avenue SE. Mowed lawn is located between the roads and the wetland.
- *Wetland determination:* In May 2013, Bellefield North Wetland was delineated and mapped based on topography and the corresponding fill associated with the adjacent

roads and development, upland vegetation and soils, and lack of hydrologic indicators. Ten GPS data points were used to delineate the boundary of Bellefield North Wetland within the project area.

3.3.1.5 8th Street Wetland

- *Size and location:* The 8th Street Wetland is located in a narrow area between 112th Avenue NE and residential development (Appendix D, Frame 5). Due to ROE limitations, only a portion of the wetland located within the City of Bellevue right-of-way of 112th Avenue NE, was delineated, and the wetland area located on private property was evaluated by visual observations from the right-of-way on the east side of the wetland. As a result, a 0.05-acre portion of the 8th Street Wetland was delineated within the project area. Based on visual observations from within the project area, aerial photograph analysis, and the location of development features, the wetland does not extend more than 30 feet west of the right-of-way. Therefore, the total size of the 8th Street Wetland is estimated to be 0.1 acre. Two sample plots were established during the delineation of 8th Street Wetland (Appendices A and B).
- *Vegetation:* Dominant vegetation includes Douglas fir, stinging nettle, and reed canarygrass (Appendices A and B).
- *Soils:* Soils are very saturated and black (10YR 2/1) loam to below 18 inches deep with some sand and rocks (Appendices A and B).
- *Hydrology:* The wetland had standing water adjacent to the fill slope from the City of Bellevue street. The remaining wetland area was saturated to the surface (Appendices A and B).
- *Wetland classification:* The 8th Street Wetland is a small, narrow wetland with PFO, PSS, and PEM vegetation classes and a depressional HGM class. The 8th Street Wetland is a Category III wetland under Ecology's rating system and the City of Bellevue's critical areas regulations (60-foot buffer).
- *Wetland function scores:* The 8th Street Wetland scores a moderate potential to improve water quality and provide opportunities to improve water quality (6 out of 32 possible maximum score). The wetland scores a moderate potential to reduce flooding and erosion and provides the opportunity to reduce flooding and erosion (24 out of 32 possible maximum score). The wetland scores a low potential and low

opportunity (11 out of 36 possible maximum score) to provide habitat functions.

Overall, the total Ecology wetland functions score for 8th Street Wetland is 41 out of a possible 100.

- *Wetland adjacent land use:* Upland areas adjacent to the wetland are dominated by fill and pavement associated with 112th Avenue NE and residential landscaping and development. Commercial development is also located north, south, and west of the wetland.
- *Wetland determination:* In May 2013, the area of 8th Street Wetland located within the right-of-way of 112th Avenue NE was delineated based on topography and the corresponding fill associated with the adjacent road, upland vegetation and soils, and lack of hydrologic indicators. Due to lack of ROE, the portion of the wetland located within private property was visually evaluated from outside the property boundary. Twenty flags were used to delineate the boundary of 8th Street Wetland within the right-of-way of 112th Avenue NE.

3.3.2 Sturtevant Creek Basin

Four wetlands were identified in the Sturtevant Creek basin within the project area: three Category III wetlands, Lake Bellevue, South Lake, and Central Lake wetlands; and one Category IV wetland, North Lake Wetland. Within this basin, the project area generally extends from about 112th Avenue SE and SE 8th Street to about 120th Avenue NE and NE 12th Street (Appendix D, Frame 9). All four of the wetlands are located near or adjacent to existing railroad tracks or commercial or residential development and receive water from surface water runoff or culverts. Wetlands in the Sturtevant Creek basin are summarized on Table 5 and shown on the figures in Appendix D, Frame 9.

Data for one sample plot was collected in this basin in an area with wetland vegetation, at the request of Sound Transit (Louther 2013), to confirm that wetland conditions were not present in this area. The sample plot data confirmed that this area did not meet the criteria for wetland conditions. The sample plot, identified as Suspect Area Upland Plot 1, is located on the west side of the old BNSF railroad tracks, south of the South Lake Wetland in a low-lying area between the railroad tracks and development to the west. This area contained wetland vegetation, such as soft rush and reed canarygrass, in a low area between upland

vegetation such as Scot's broom, Himalayan blackberry, and various grass and herbaceous species. Soils in the sample plot were comprised of gravel and sandy loam resembling fill material that did not meet the criteria of hydric soil, and it was difficult to penetrate the ground more than about 7 inches deep. No saturation or standing water was observed in the sample plot. The location of Suspect Area Upland Sample Plot 1 is shown on the figures in Appendix D, Frame 9, and included with the sample plot data in Appendix A and the field data forms in Appendix B.

3.3.2.1 *Lake Bellevue Wetland*

- *Size and location:* Lake Bellevue Wetland is regulated by the City of Bellevue as a wetland and not a lake because it was historically a wetland that was dredged to create open water habitat. The wetland is located east of the old BNSF railroad tracks south of NE 12th St. and north of NE 8th St. (Appendix D, Frame 9). The lake has commercial and residential structures built on piles that line the shoreline and are over much of the open water portion of the lake and wetland. The western wetland boundary of the wetland, 0.54 acre, was delineated within the project area. Based on visual observations from within the project area, aerial photograph analysis, and the location of development features, the total size of the wetland is estimated to be 7.0 acres. A narrow upland area is located between the wetland and an adjacent wetland and the old BNSF railroad tracks. Two sample plots were established during the delineation of Lake Bellevue Wetland (Appendices A and B).
- *Vegetation:* Dominant vegetation was black cottonwood, red alder, spirea, reed canarygrass, English ivy (*Hedera helix*), and horsetail (Appendices A and B).
- *Soils:* The surface layer to about 2 inches deep was a very dark gray to black (10YR 2/1) loam with dense roots and sand/gravel within the profile. The second layer extends from about 2 to at least 18 inches deep, and is black (10YR 2/1) sandy loam with no redox features and all sizes of rock and gravel (Appendices A and B).
- *Hydrology:* Soils were saturated to the surface in the soil data pit, with the water table present about 2 inches from the surface (Appendices A and B).
- *Wetland classification:* Lake Bellevue Wetland is a large depressional feature (lake) with only PAB vegetation class and a depressional HGM class. Tree, shrub, and emergent vegetation was located in the delineated portion of the wetland; however,

this is only a small percentage of the overall wetland system, and therefore, the wetland is described as having a PAB vegetation class. The wetland soils are saturated and seasonally inundated. Lake Bellevue Wetland is a Category III wetland under Ecology's rating system and the City of Bellevue's critical areas regulations (60-foot buffer).

- *Wetland function scores:* Lake Bellevue Wetland was scored with a low potential to improve water quality and provide opportunities to improve water quality (2 out of 32 possible maximum score). The wetland scores a moderate potential to reduce flooding and erosion and provides the opportunity to reduce flooding and erosion (16 out of 32 possible maximum score). The wetland scores a moderate potential and low opportunity (12 out of 36 possible maximum score) to provide habitat functions. Overall, the total Ecology wetland functions score for Lake Bellevue Wetland is 30 out of a possible 100.
- *Wetland adjacent land use:* Upland areas adjacent to the wetland are dominated by fill associated with railroad tracks and the commercial business park, which is built over and adjacent to the wetland. The majority of the wetland is surrounded by parking lots that support the commercial development buildings over the water.
- *Wetland determination:* Lake Bellevue Wetland was delineated and mapped in April 2013 based on topography, the OHWM, upland soils, and lack of hydrologic indicators. Twenty-eight flags were used to delineate the boundary of Lake Bellevue Wetland within the project area, but the entire area was not delineated.

3.3.2.2 *South Lake Wetland*

- *Size and location:* South Lake Wetland is located in a narrow area between railroad tracks and development on the shoreline of Lake Bellevue (Appendix D, Frame 9). The entire wetland boundary was delineated, approximately 0.09 acre within the project area. Upland area is located between the wetland and Lake Bellevue. Two sample plots were established during the delineation of South Lake Wetland (Appendices A and B).
- *Vegetation:* Dominant vegetation includes Hooker's willow (*Salix hookeriana*), salmonberry, spirea, and reed canarygrass, with giant horsetail (*Equisetum*

giganteum), Himalayan blackberry, and English ivy also occurring (Appendices A and B).

- *Soils:* The surface layer to about 3 inches deep was a very dark grayish brown (10YR 3/2) silt with dense roots within the profile. The second layer extends from about 3 to at least 18 inches deep, and is black (10YR 2/1) loam with no redox features (Appendices A and B).
- *Hydrology:* Soils were saturated to the surface in the soil data pit, with the water table present about 1 inch from the surface (Appendices A and B).
- *Wetland classification:* South Lake Wetland is a small, narrow wetland with PFO, PSS, and PEM vegetation classes and a depressional HGM class. The wetland soils are saturated and seasonally inundated. South Lake Wetland is a Category III wetland under Ecology's rating system and the City of Bellevue's critical areas regulations (60-foot buffer).
- *Wetland function scores:* South Lake Wetland was scored with a moderate potential to improve water quality and provide opportunities to improve water quality (14 out of 32 possible maximum score). The wetland scores a moderate potential to reduce flooding and erosion and provides the opportunity to reduce flooding and erosion (16 out of 32 possible maximum score). The wetland scores a moderate potential and low opportunity (13 out of 36 possible maximum score) to provide habitat functions. Overall, the total Ecology wetland functions score for South Lake Wetland is 43 out of a possible 100.
- *Wetland adjacent land use:* Upland areas adjacent to the wetland are dominated by fill associated with railroad tracks and pavement associated with development. Commercial development along the shoreline of Lake Bellevue is located to the east. Commercial development is also located west of the railroad tracks.
- *Wetland determination:* South Lake Wetland was delineated and mapped in February 2013 based on topography and the corresponding fill associated with the adjacent railroad track berm, upland soils, and lack of hydrologic indicators. Eighteen flags were used to delineate the boundary of South Lake Wetland within the project area.

3.3.2.3 Central Lake Wetland

- *Size and location:* Central Lake Wetland is located in a narrow area between railroad

tracks and development on the shoreline of Lake Bellevue. The entire wetland boundary was delineated, approximately 0.03 acre within the project area (Appendix D, Frame 9). Upland area is located between the wetland and Lake Bellevue. Two sample plots were established during the delineation of Central Lake Wetland (Appendices A and B).

- *Vegetation:* Dominant vegetation includes spirea, reed canarygrass, water purslane (*Lythrum portula*), and Watson's willow herb (*Epilobium watsonii*), with red-osier dogwood and Himalayan blackberry also occurring (Appendices A and B).
- *Soils:* The surface layer to about 3 inches deep was very dark gray (10YR 3/1) silt. The second layer extends from about 3 to about 8 inches deep, and is grayish brown (10YR 5/2) sandy loam, with gravel with yellowish brown (10YR 5/6) redox features. The third layer extends from about 8 to at least 18 inches deep, and is greenish gray (Gley 1 5/5G) sandy clay with gravel, and angular rock with no redox features (Appendices A and B).
- *Hydrology:* Soils were saturated to the surface in the soil data pit, with the water table present about 5 inches from the surface (Appendices A and B).
- *Wetland classification:* Central Lake Wetland is a small, narrow wetland with PSS and PEM vegetation classes and a depressional HGM class. The wetland soils are saturated and seasonally inundated. Central Lake Wetland is a Category III wetland under Ecology's rating system and the City of Bellevue's critical areas regulations (60-foot buffer).
- *Wetland function scores:* Central Lake Wetland scores a low potential to improve water quality and provide opportunities to improve water quality (10 out of 32 possible maximum score). The wetland scores a moderate potential to reduce flooding and erosion and provides the opportunity to reduce flooding and erosion (20 out of 32 possible maximum score). The wetland scores a moderate potential and low opportunity (11 out of 36 possible maximum score) to provide habitat functions. Overall, the total Ecology wetland functions score for Central Lake Wetland is 41 out of a possible 100.
- *Wetland adjacent land use:* Upland areas adjacent to the wetland are dominated by fill associated with railroad tracks and pavement associated with development. Commercial development along the shoreline of Lake Bellevue is located to the east. Commercial development is also located west of the railroad tracks.

- *Wetland determination:* In February 2013, Central Lake Wetland was delineated and mapped based on topography and the corresponding fill associated with the adjacent railroad track berm, upland soils, and lack of hydrologic indicators. Five flags were used to delineate the boundary of Central Lake Wetland within the project area.

3.3.2.4 North Lake Wetland

- *Size and location:* North Lake Wetland is located in a narrow area between railroad tracks and development. The entire wetland boundary was delineated, approximately 0.04 acre within the project area (Appendix D, Frame 9). Two sample plots were established during the delineation of North Lake Wetland (Appendices A and B).
- *Vegetation:* Dominant vegetation includes red alder, Scouler's willow (*Salix scouleriana*), soft rush, and reed canarygrass, with Himalayan blackberry and Watson's willow-herb also occurring (Appendices A and B).
- *Soils:* The surface layer to about 5 inches deep was a black (10YR 2/1) loam with cobbles and angular rock. The second layer extends from about 5 to about 8 inches, and is very dark gray (10YR 3/1) loam with angular rock. The third layer extends from about 8 to at least 18 inches deep, and is gray (10YR 5/1) sandy clay with angular rock and yellowish brown (10YR 5/6) redox features (Appendices A and B).
- *Hydrology:* Soils were saturated to the surface in the soil data pit, with the water table present about 3 inches from the surface (Appendices A and B).
- *Wetland classification:* North Lake Wetland is a small, narrow wetland with PFO and PEM vegetation classes and a slope HGM class. The wetland soils are saturated and seasonally inundated. North Lake Wetland is a Category IV wetland under Ecology's rating system and the City of Bellevue's critical areas regulations (no buffer due to wetland size of less than 2,500 square feet).
- *Wetland function scores:* North Lake Wetland scores a low potential to improve water quality and provide opportunities to improve water quality (8 out of 24 possible maximum score). The wetland scores a low potential to reduce flooding and erosion and provides the opportunity to reduce flooding and erosion (4 out of 16 possible maximum score). The wetland scores a low potential and low opportunity (10 out of 36 possible maximum score) to provide habitat functions. Overall, the total Ecology wetland functions score for North Lake Wetland is 22 out of a possible 76.

- *Wetland adjacent land use:* Upland areas adjacent to the wetland are dominated by fill associated with railroad tracks and pavement associated with development. Commercial development is located west of the wetland. Commercial development along the shoreline of Lake Bellevue is located east of the railroad tracks.
- *Wetland determination:* In February 2013, North Lake Wetland was delineated and mapped based on topography and the corresponding fill associated with the adjacent railroad track berm, upland soils, and lack of hydrologic indicators. Six flags were used to delineate the boundary of North Lake Wetland within the project area.

3.3.3 West Tributary Basin

There are eight wetlands in the West Tributary basin within the project area: one Category II wetland, Kelsey West Tributary Pond Wetland; six Category III wetlands, BNSF Southwest, BNSF East, BNSF West, BNSF Northeast, BNSF North, and Kelsey West Tributary; and one Category IV wetland, BNSF Northwest Wetland. Within this basin, the project area generally extends from about 120th Avenue NE and NE 12th Street to about 130th Avenue NE and NE 15th Place (Figure 2). All eight of the wetlands are located near or adjacent to roads or commercial or residential development, and receive water from surface water runoff and culverts. Kelsey West Tributary Pond Wetland and Kelsey West Tributary Stream Wetland are associated with the West Tributary to Kelsey Creek. Wetlands in the West Tributary basin are summarized on Table 5 and shown on the figures in Appendix D, Frames 10 and 11.

Data for three sample plots were collected in this basin in areas with wetland vegetation, at the request of Sound Transit (Louther 2013), to confirm that wetland conditions were not present in these areas. The sample plot data confirmed that these three areas do not meet the criteria for wetland conditions. The first sample plot, identified as Suspect Area Upland Plot 2, is located on the east side of the old BNSF railroad tracks, south of the BNSF East Wetland in a low-lying area between the railroad tracks and development to the east. This area contained wetland vegetation, such as soft rush and reed canarygrass, in a low area between upland vegetation such as Scot's broom, Himalayan blackberry, and various grass and herbaceous species. Soils in the sample plot were comprised of gravel and sandy loam resembling fill material that did not meet the criteria of hydric soil, and ground penetration

was not possible beyond about 10 inches deep. No saturation or standing water was observed in the sample plot.

The second sample plot, identified as Suspect Area Upland Plot 3, is located along the west side of a gravel parking lot, south of the Kelsey West Tributary Pond Wetland, between the parking lot and the toe of slope of a berm. This area contained soft rush wetland vegetation with some sparse grass and herbaceous species. Soils in the sample plot were comprised of gravel and sandy loam resembling fill material that did not meet the criteria of hydric soil, and it was difficult to penetrate the ground more than about 5 inches deep. No saturation or standing water was observed in the sample plot.

The third sample plot, identified as Suspect Area Upland Plot 4, is located along the south side of the gravel parking lot, south of the Kelsey West Tributary Pond Wetland, between the parking lot and the toe of slope of a berm. This area also contained soft rush wetland vegetation with some sparse grass and herbaceous species. Soils in the sample plot were comprised of gravel and sandy loam resembling fill material that did not meet the criteria of hydric soil, and it was difficult to penetrate the ground more than about 7 inches deep. No saturation or standing water was observed in the sample plot. The location of Suspect Area Upland Sample Plot 2 is shown on the figures in Appendix D, Frame 10, and Suspect Area Upland Sample Plots 3 and 4 are shown in Appendix D, Frame 11. These data for these 3 sample plots are included in Appendix A, and the field data forms are provided in Appendix B.

3.3.3.1 *BNSF Southwest Wetland*

- *Size and location:* BNSF Southwest Wetland is located adjacent to railroad tracks with commercial development located to the west. The entire wetland boundary was delineated, approximately 0.12 acre within the project area (Appendix D, Frame 10). Two sample plots were established during the delineation of BNSF Southwest Wetland (Appendices A and B).
- *Vegetation:* Dominant vegetation includes black cottonwood, Pacific willow, red alder, reed canarygrass, and Colonial bentgrass (Appendices A and B).
- *Soils:* The surface layer extends to about 2 inches deep, and is dark grayish brown

(10YR 4/2) sandy silt with gravel and no redox features. The second layer extends from about 2 to about 6 inches deep, and is dark grayish brown (10YR 4/2) sandy silt with gravel and cobbles and gray (10YR 5/1) redox features. The third layer extends from about 6 to below 18 inches deep, and is dark grayish brown (10YR 4/2) sandy silt with gravel and gray (10YR 5/1) redox features (Appendices A and B).

- *Hydrology:* Soils were saturated to the surface in the soil data pit, with the water table present about 6 inches from the surface (Appendices A and B). BNSF Southwest Wetland is connected to BNSF West Wetland to the north via a jurisdictional ditch (Section 5) that runs along the railroad track fill prism.
- *Wetland classification:* BNSF Southwest Wetland is a small, narrow wetland with PFO and PEM vegetation classes and depressional and slope HGM classes. The wetland soils are saturated and seasonally inundated. BNSF Southwest Wetland is a Category III wetland under Ecology's rating system and the City of Bellevue's critical areas regulations (60-foot buffer).
- *Wetland function scores:* BNSF Southwest Wetland scores a moderate potential to improve water quality and provide opportunities to improve water quality (14 out of 32 possible maximum score). The wetland scores a moderate potential to reduce flooding and erosion and provides the opportunity to reduce flooding and erosion (16 out of 32 possible maximum score). The wetland scores a moderate potential and low opportunity to provide habitat functions (12 out of 36 possible maximum score). Overall, the total Ecology wetland functions score for BNSF Southwest Wetland is 42 out of a possible 100.
- *Wetland adjacent land use:* Upland areas adjacent to the wetland are dominated by fill associated with railroad tracks and pavement associated with development. Commercial development is located to the east. Commercial development is also located west of the railroad tracks.
- *Wetland determination:* BNSF Southwest Wetland was delineated and mapped in April 2013 based on topography and corresponding fill associated with the adjacent railroad track berm, upland soils, and lack of hydrologic indicators. Twelve flags were used to delineate the boundary of BNSF Southwest Wetland within the project area.

3.3.3.2 BNSF East Wetland

- *Size and location:* BNSF East Wetland is located between railroad tracks and commercial development and has a long, linear ditch shape. A chain link fence runs along the south side of the wetland that provides the project area boundary. A riprap embankment is located about 5 feet east of the fence. The wetland appears to extend a few feet east of the fence. The 0.06 acre wetland boundary (up to the fence) was delineated within the project area. Based on visual observations from within the project area and the location of the embankment south of the chain link fence, the total size of the wetland is estimated to be 0.1 acre (Appendix D, Frame 10). Two sample plots were established during the delineation of BNSF East Wetland (Appendices A and B).
- *Vegetation:* Dominant vegetation includes cattail (*Typha latifolia*), common duckweed (*Lemna minor*), reed canarygrass, and soft rush (Appendices A and B).
- *Soils:* The surface layer was duff and leaf litter to about 1 inch deep. The second layer extends from about 1 to below 18 inches deep, and is gray (10YR 5/1) silt loam with no redox features (Appendices A and B).
- *Hydrology:* Standing water was about 5 inches deep in the area of the soil data pit (Appendices A and B). Culverts are located at both the north and south ends of the wetland. Water within the wetland was not flowing at the time of the investigation.
- *Wetland classification:* BNSF East Wetland is a small, narrow wetland with a PEM vegetation class and a depressional HGM class. The wetland soils are saturated and seasonally inundated. BNSF East Wetland is a Category III wetland under Ecology's rating system and the City of Bellevue's critical areas regulations (60-foot buffer).
- *Wetland function scores:* BNSF East Wetland scores a moderate potential to improve water quality and provide opportunities to improve water quality (14 out of 32 possible maximum score). The wetland scores a moderate potential to reduce flooding and erosion and provides the opportunity to reduce flooding and erosion (16 out of 32 possible maximum score). The wetland scores a low potential and low opportunity to provide habitat functions (7 out of 36 possible maximum score). Overall, the total Ecology wetland functions score for BNSF East Wetland is 37 out of a possible 100.
- *Wetland adjacent land use:* Upland areas adjacent to the wetland are dominated by fill

associated with railroad tracks and pavement associated with development.

Commercial development is located to the east. Commercial development is also located west of the railroad tracks.

- *Wetland determination:* In February 2013, BNSF East Wetland was delineated and mapped based on topography and corresponding fill associated with the adjacent railroad track berm, upland soils, and lack of hydrologic indicators. Fourteen flags were used to delineate the boundary of BNSF East Wetland within the project area.

3.3.3.3 BNSF West Wetland

- *Size and location:* BNSF West Wetland is located adjacent to railroad tracks and has commercial development located to the west. Field ecologists delineated 0.63 acre of the BNSF West Wetland within the project area. The wetland extends outside the project area to the west (Appendix D, Frame 10). Based on visual observations from within the project area, aerial photograph analysis, and the location of development features that would limit the extent of the wetland system, the total wetland size is estimated to be 0.8 acre. The majority of the BNSF West Wetland is located within the West Tributary basin, with a small (northern) portion of the wetland located within the Sturtevant Creek basin. Four sample plots were established during the delineation of BNSF West Wetland (Appendices A and B).
- *Vegetation:* Dominant vegetation includes Scouler's willow, red alder, spirea, lady fern, Colonial bentgrass, reed canarygrass, and piggyback plant (*Tolmiea menziesii*) (Appendices A and B).
- *Soils:* Data was collected in two wetland data plots for this wetland system. Wetland soils were typically dark gray (10YR 4/1) with yellowish brown (10YR 5/6) redox features. Wetland soil textures were silt loam with various densities of gravel and cobble (Appendices A and B).
- *Hydrology:* Soils were saturated to the surface in the soil data pits, with the water table typically present about 2 inches from the surface. BNSF West Wetland is connected to BNSF Southwest Wetland to the south and to BNSF Northwest Wetland to the north via jurisdictional ditches JD-1 and JD-2, respectively (Section 5.2), that run along the railroad track fill prism (Appendices A and B).
- *Wetland classification:* BNSF West Wetland has PFO, PSS, and PEM vegetation

classes and depressional and slope HGM classes. The wetland soils are saturated and seasonally inundated. BNSF West Wetland is a Category III wetland under Ecology's rating system and the City of Bellevue's critical areas regulations (60-foot buffer).

- *Wetland function scores:* BNSF West Wetland scores a moderate potential to improve water quality and provide opportunities to improve water quality (14 out of 32 possible maximum score). The wetland scores a moderate potential to reduce flooding and erosion and provides the opportunity to reduce flooding and erosion (16 out of 32 possible maximum score). The wetland scores a moderate potential and low opportunity to provide habitat functions (12 out of 36 possible maximum score). Overall, the total Ecology wetland functions score for BNSF West Wetland is 42 out of a possible 100.
- *Wetland adjacent land use:* Upland areas adjacent to the wetland are dominated by fill associated with railroad tracks and pavement associated with development. Commercial development is located to the west.
- *Wetland determination:* In April 2013, BNSF West Wetland was delineated and mapped based on topography and corresponding fill associated with the adjacent railroad track berm, upland soils, and lack of hydrologic indicators. Forty-eight flags were used to delineate the boundary of BNSF West Wetland within the project area.

3.3.3.4 *BNSF Northeast Wetland*

- *Size and location:* BNSF Northeast Wetland is located between railroad tracks, with commercial development located outside the railroad tracks. The entire wetland boundary was delineated, approximately 0.02 acre within the project area (Appendix D, Frame 10). Two sample plots were established during the delineation of BNSF Northeast Wetland (Appendices A and B).
- *Vegetation:* Dominant vegetation includes red alder, black cottonwood, spirea, and water purslane (Appendices A and B).
- *Soils:* The surface layer was (10YR 4/1) dark gray silt loam with dense root material to about 7 inches deep. The second layer extends from about 7 to about 10 inches and is (10YR 4/1) dark gray silt loam with no redox features. The third layer extends from about 10 to below 18 inches deep and is (10YR 4/1) dark gray loam with gravel and no redox features (Appendices A and B).

- *Hydrology:* Saturation was at the surface and the water table was 1 inch from the surface in the soil data pit (Appendices A and B). Culverts are located at both the north and south ends of the wetland. The culvert at the north end of this wetland is connected to BNSF North Wetland, and the culvert at the south end carries water from the west side of the BNSF railroad tracks. Standing water was present in the majority of the wetland at the time of the investigation.
- *Wetland classification:* BNSF Northeast Wetland is a small, narrow wetland with PFO and PSS vegetation classes and a depressional HGM class. The wetland soils are saturated and seasonally inundated. BNSF Northeast Wetland is a Category III wetland under Ecology's rating system and the City of Bellevue's critical areas regulations (60-foot buffer).
- *Wetland function scores:* BNSF Northeast Wetland scores a moderate potential to improve water quality and provide opportunities to improve water quality (14 out of 32 possible maximum score). The wetland scores a moderate potential to reduce flooding and erosion and provides the opportunity to reduce flooding and erosion (16 out of 32 possible maximum score). The wetland scores a low potential and low opportunity to provide habitat functions (10 out of 36 possible maximum score). Overall, the total Ecology wetland functions score for BNSF Northeast Wetland is 40 out of a possible 100.
- *Wetland adjacent land use:* Upland areas adjacent to the wetland are dominated by fill associated with railroad tracks. Commercial development is located to the east and west of the railroad tracks.
- *Wetland determination:* In May 2013, BNSF Northeast Wetland was delineated and mapped based on topography and corresponding fill associated with the adjacent railroad track berm, upland soils, and lack of hydrologic indicators. Seven flags were used to delineate the boundary of BNSF Northeast Wetland within the project area.

3.3.3.5 *BNSF Northwest Wetland*

- *Size and location:* BNSF Northwest Wetland is located adjacent to railroad tracks with commercial development located to the west. The entire wetland boundary was delineated, approximately 0.06 acre within the project area (Appendix D, Frame 10). Two sample plots were established during the delineation of BNSF Northwest

Wetland (Appendices A and B).

- *Vegetation:* Dominant vegetation includes Pacific willow, lady fern, soft rush, and English ivy (Appendices A and B).
- *Soils:* The surface layer extends to about 3 inches deep, and is very dark grayish brown (10YR 3/2) silt loam with gray (10YR 5/1) redox features. The second layer extends from about 2 to about 18 inches deep, and is dark gray (10YR 4/1) sandy loam with gravel and cobbles and dark yellowish brown (10YR 4/4) redox features (Appendices A and B).
- *Hydrology:* Soils were saturated to the surface in the soil data pit, with the water table typically present about 8 inches from the surface (Appendices A and B). BNSF Northwest Wetland is connected to BNSF West Wetland to the south via a jurisdictional ditch, JD-2, (Section 5.2) that runs along the railroad track fill prism.
- *Wetland classification:* BNSF Northwest Wetland is a small, narrow wetland with PFO and PEM vegetation classes and depressional and slope HGM classes. The wetland soils are saturated and seasonally inundated. BNSF Northwest Wetland is a Category IV wetland under Ecology's rating system and the City of Bellevue's critical areas regulations (40-foot buffer).
- *Wetland function scores:* BNSF Northwest Wetland scores a low potential to improve water quality and provide opportunities to improve water quality (8 out of 32 possible maximum score). The wetland scores a low potential to reduce flooding and erosion and provides the opportunity to reduce flooding and erosion (6 out of 32 possible maximum score). The wetland scores a low potential and low opportunity to provide habitat functions (10 out of 36 possible maximum score). Overall, the total Ecology wetland functions score for BNSF Northwest Wetland is 24 out of a possible 100.
- *Wetland adjacent land use:* Upland areas adjacent to the wetland are dominated by fill associated with railroad tracks and pavement associated with commercial development to the west.
- *Wetland determination:* In April 2013, BNSF Northwest Wetland was delineated and mapped based on topography and corresponding fill associated with the adjacent railroad track berm, upland soils, and lack of hydrologic indicators. Eight flags were used to delineate the boundary of BNSF Northwest Wetland within the project area.

3.3.3.6 BNSF North Wetland

- *Size and location:* BNSF North Wetland is located between railroad tracks with commercial development located outside the railroad tracks. The entire wetland boundary was delineated, approximately 0.02 acre within the project area (Appendix D, Frame 10). Two sample plots were established during the delineation of BNSF North Wetland (Appendices A and B).
- *Vegetation:* Dominant vegetation includes black cottonwood, Pacific willow, spirea, and bittersweet nightshade (*Solanum dulcamara*) (Appendices A and B).
- *Soils:* The surface layer was (10YR 3/1) very dark gray silt loam with dense root material to about 2 inches deep. The second layer extends from about 2 to about 6 inches and is (10YR 3/1) very dark gray silt loam with no redox features. The third layer extends from about 6 to below 18 inches deep and is (10YR 5/1) gray loam with gravel and (10YR 5/4) yellowish brown redox features (Appendices A and B).
- *Hydrology:* Saturation was at the surface and the surface water was 1 inch deep in the soil data pit (Appendices A and B). Culverts are located at both the north and south ends of the wetland. The culvert at the south end of this wetland is connected to BNSF Northeast Wetland. The culvert on the north end is presumed to drain to the West tributary to Kelsey Creek East of 120th Avenue NE. Standing water was present in the majority of the wetland at the time of the investigation.
- *Wetland classification:* BNSF North Wetland is a small, narrow wetland with PFO and PSS vegetation classes and depressional and slope HGM classes. The wetland soils are saturated and seasonally inundated. BNSF North Wetland is a Category III wetland under Ecology's rating system and the City of Bellevue's critical areas regulations (60-foot buffer).
- *Wetland function scores:* BNSF North Wetland scores a moderate potential to improve water quality and provide opportunities to improve water quality (14 out of 32 possible maximum score). The wetland scores a moderate potential to reduce flooding and erosion and provide the opportunity to reduce flooding and erosion (16 out of 32 possible maximum score). The wetland scores a low potential and low opportunity to provide habitat functions (10 out of 36 possible maximum score). Overall, the total Ecology wetland functions score for BNSF North Wetland is 40 out of a possible 100.

- *Wetland adjacent land use:* Upland areas adjacent to the wetland are dominated by fill associated with railroad tracks. Commercial development is located to the east and west of the railroad tracks.
- *Wetland determination:* In May 2013, BNSF North Wetland was delineated and mapped based on topography and corresponding fill associated with the adjacent railroad track berm, upland soils, and lack of hydrologic indicators. Eleven flags were used to delineate the boundary of BNSF North Wetland within the project area.

3.3.3.7 *Kelsey West Tributary Pond Wetland*

- *Size and location:* Kelsey West Tributary Pond Wetland is located east of 124th Avenue NE and is entirely surrounded by commercial development (Appendix D, Frame 11). This wetland was delineated by Parametrix in 2011 as part of a City of Bellevue project, and the data from that delineation was incorporated as part of this report (Parametrix 2012). The 2011 delineation was verified in 2013 based on the information in the 2012 report and visual observations from outside the property. The wetland is 5.98 acres.
- *Vegetation:* This wetland is dominated by red alder, reed canarygrass, Pacific willow, spirea, and cattail.
- *Soils:* Hydric soil conditions were verified in the field.
- *Hydrology:* The wetland is associated with the West Tributary of Kelsey Creek, and standing water was observed in the majority of the wetland at the time of the investigation.
- *Wetland classification:* Kelsey West Tributary Pond Wetland is a large wetland with PFO and PEM vegetation classes and depressional and riverine HGM classes. Kelsey West Tributary Pond Wetland is a Category II wetland under Ecology's rating system and the City of Bellevue's critical areas regulations.
- *Wetland function scores:* Kelsey West Tributary Pond Wetland scores a high potential to improve water quality and provide opportunities to improve water quality (22 out of 32 possible maximum score). The wetland scores a high potential to reduce flooding and erosion and provides the opportunity to reduce flooding and erosion (24 out of 32 possible maximum score). The wetland scores a moderate potential and opportunity to provide habitat functions (17 out of 36 possible

maximum score). Overall, the total Ecology wetland functions score for Kelsey West Tributary Pond Wetland is 63 out of a possible 100.

- *Wetland adjacent land use:* Upland areas adjacent to the wetland are dominated by fill and pavement associated with 124th Avenue NE and commercial development. Commercial development is located north, south, and east of the wetland.
- *Wetland determination:* Kelsey West Tributary Pond Wetland was evaluated based on prior delineations (Parametrix 2012), and wetland conditions were verified during the site visit.

3.3.3.8 *Kelsey West Tributary Stream Wetland*

- *Size and location:* Kelsey West Tributary Stream Wetland is located in a narrow area between commercial developments. The entire wetland boundary was delineated, approximately 0.04 acre within the project area (Appendix D, Frame 11). Kelsey West Tributary Stream Wetland is associated with the West Tributary of Kelsey Creek, identified as West Tributary to Kelsey Creek Stream (Section 4.2). Four sample plots were established during the delineation of Kelsey West Tributary Stream Wetland, two each on the left and right banks of the creek (Appendices A and B).
- *Vegetation:* Dominant vegetation includes Pacific willow, red-osier dogwood, bittersweet nightshade, and reed canarygrass, with soft rush and Himalayan blackberry also occurring (Appendices A and B).
- *Soils:* Soils to below 18 inches deep were a very dark grayish brown (10YR 3/1) silt loam with no redox features (Appendices A and B).
- *Hydrology:* Soils were saturated to the surface in the soil data pits, with the water table present about 5 inches from the surface (Appendices A and B). The wetland is associated with the left and right banks of the West Tributary of Kelsey Creek (Section 4.2).
- *Wetland classification:* Kelsey West Tributary Stream Wetland is a small, narrow wetland with PFO, PSS, and PEM vegetation classes and a riverine HGM class. The wetland soils are saturated and seasonally inundated, and the wetland is associated with a permanently flowing stream. Kelsey West Tributary Stream Wetland is a Category III wetland under Ecology's rating system and the City of Bellevue's critical areas regulations (60-foot buffer).

- *Wetland function scores:* Kelsey West Tributary Stream Wetland scores a moderate potential to improve water quality and provide opportunities to improve water quality (16 out of 32 possible maximum score). The wetland scores a moderate potential to reduce flooding and erosion and provide the opportunity to reduce flooding and erosion (18 out of 32 possible maximum score). The wetland scores a moderate potential and opportunity (16 out of 36 possible maximum score) to provide habitat functions. Overall, the total Ecology wetland functions score for Kelsey West Tributary Stream Wetland is 50 out of a possible 100.
- *Wetland adjacent land use:* Both the left and right banks of the wetland and associated stream channel are dominated by fill associated with development. At the top of the banks there is a narrow strip of buffer vegetation that is primarily dominated by Himalayan blackberry, Scot's broom, and weedy herbaceous plant species. A large commercial building is located directly at the eastern edge of the property boundary, approximately 5 feet from the edge of the stream channel. The remaining area immediately to the west and south of the stream and wetland are paved and gravel parking lots. Another commercial building is located further to the west. Kelsey West Tributary Pond Wetland is located to the northwest.
- *Wetland determination:* In February 2013, Kelsey West Tributary Stream Wetland was delineated and mapped based on topography and the corresponding fill associated with adjacent commercial development, upland soils, and lack of hydrologic indicators. Ten flags were used to delineate the boundary of Kelsey West Tributary Stream Wetland within the project area.

3.3.4 Kelsey Creek Basin

There is one wetland in the Kelsey Creek basin within the project area, 136th Place Wetland, a Category III wetland. Within this basin, the project area generally extends from about 130th Avenue NE and NE 15th Place to about NE 20th Street and 136th Place NE (Figure 2). The 136th Place Wetland is located near or adjacent to roads and commercial development and receives water from surface water runoff and culverts. The wetland in the Kelsey Creek basin is shown on Table 5 and the figures in Appendix D, Frame 13.

3.3.4.1 136th Place Wetland

- *Size and location:* The 136th Place Wetland is located in a narrow area between commercial developments (Appendix D, Frame 13). The entire wetland boundary was delineated, approximately 0.03 acre within the project area. Two sample plots were established during the delineation of 136th Place Wetland (Appendices A and B).
- *Vegetation:* Dominant vegetation includes red alder, Pacific willow, bittersweet nightshade, and reed canarygrass, with horsetail and English ivy also occurring (Appendices A and B).
- *Soils:* The surface layer to below 18 inches deep was a black (10YR 2/1) silt with organic material within the profile with no redox features (Appendices A and B).
- *Hydrology:* Standing water and saturated soils were present at the surface in the soil data pit (Appendices A and B). The 136th Place Wetland is identified on City of Bellevue critical areas maps (Bellevue 2013b) as being associated with a non-fish-bearing Type N stream identified as a tributary to Kelsey Creek. However, no flow was observed within the channel during the field investigation, and there was no evidence of regular stream flow occurring within the channel. Since the field investigation, several field visits and discussions with City staff indicate that the majority of the flow of the Unnamed Tributary to Kelsey Creek is conveyed through a bypass/overflow pipe that was installed to address flooding issues. The portion of the Unnamed Tributary associated with the 136th Street Wetland is that smaller percentage of the stream that is not conveyed through the bypass pipe.
- *Wetland classification:* 136th Place Wetland is a small, narrow wetland with PFO, PSS, and PEM vegetation classes and a depressional HGM class. The wetland soils are saturated and seasonally inundated. The 136th Place Wetland is a Category III wetland under Ecology's rating system and the City of Bellevue's critical areas regulations (60-foot buffer).
- *Wetland function scores:* 136th Place Wetland scores a low potential to improve water quality and provide opportunities to improve water quality (10 out of 32 possible maximum score). The 136th Place Wetland scores a moderate potential to reduce flooding and erosion and provide the opportunity to reduce flooding and erosion (20 out of 32 possible maximum score). The wetland scores a low potential

and low opportunity (10 out of 36 possible maximum score) to provide habitat functions. Overall, the total Ecology wetland functions score for 136th Place Wetland is 40 out of a possible 100.

- *Wetland adjacent land use:* Upland areas adjacent to the wetland are dominated by fill associated with commercial developments and parking lots. A footbridge that connects the two commercial buildings located on the east and west sides of the wetland crosses the middle portion of the wetland.
- *Wetland determination:* In April 2013, 136th Place Wetland was delineated and mapped in April 2013 based on topography and the corresponding fill associated with the adjacent development, upland soils and lack of hydrologic indicators. Ten flags were used to delineate the boundary of 136th Place Wetland within the project area.

3.3.5 Valley Creek Basin

There are three wetlands in the Valley Creek basin within the project area: one Category II wetland, SR 520 West Wetland; and two Category III wetlands, Valley Creek and SR 520 East wetlands. Within this basin, the project area generally extends from about 130th Avenue NE and NE 15th Place to about SR 520 and 148th Avenue NE (Figure 2). All three of the wetlands are located near or adjacent to roads or commercial development and receive water from surface water runoff or culverts. Wetlands in the Valley Creek basin are summarized on Table 5 and shown on the figures in Appendix D, Frames 13 and 14.

3.3.5.1 SR 520 West Wetland

- *Size and location:* SR 520 West Wetland is located in a narrow area between commercial development and SR 520, with 140th Avenue NE located to the east of the wetland (Appendix D, Frame 13). The wetland is located at the toe of slope of the SR 520 right-of-way. Approximately 0.51 acre of SR 520 West Wetland within the project area was delineated. The wetland extends outside the project area to the west. Based on visual observations from within the project area, aerial photograph analysis, and the location of development features that would limit the extent of the wetland system, the total wetland size is estimated to be 0.6 acre. Four sample plots were established during the delineation of SR 520 West Wetland (Appendices A and B).

- *Vegetation:* Dominant vegetation includes red alder, black cottonwood, Pacific willow, red-osier dogwood, spirea, water parsley (*Oenanthe sarmentosa*), and skunk cabbage, with horsetail and Himalayan blackberry also occurring (Appendices A and B).
- *Soils:* Soils are typically very dark gray (10YR 3/1) silt loam to sandy loam with gravel down to more than 18 inches deep with no redox features and a surface layer of 1 to 2 inches of duff/leaf litter (Appendices A and B).
- *Hydrology:* Standing water was present from 2 to 4 inches deep in the soil data pits (Appendices A and B). Culverts are located at the west and east end of the wetland. The culvert at the west end of the wetland appeared to be associated with stormwater runoff from the development south of the wetland. The culvert at the east end of the wetland flows beneath 140th Avenue NE towards Valley Creek. Standing water was present for about half of the wetland at the time of the investigation.
- *Wetland classification:* SR 520 West Wetland is a small, narrow wetland with PFO, PSS, and PEM vegetation classes and depressional and slope HGM classes. The wetland soils are saturated and seasonally inundated. SR 520 West Wetland is a Category III wetland under Ecology's rating system and the City of Bellevue's critical areas regulations (60-foot buffer).
- *Wetland function scores:* SR 520 West Wetland scores a moderate potential to improve water quality and provide opportunities to improve water quality (18 out of 32 possible maximum score). SR 520 West Wetland scores a moderate potential to reduce flooding and erosion and provides the opportunity to reduce flooding and erosion (16 out of 32 possible maximum score). The wetland scores a moderate potential and low opportunity (14 out of 36 possible maximum score) to provide habitat functions. Overall, the total Ecology wetland functions score for SR 520 West Wetland is 48 out of a possible 100.
- *Wetland adjacent land use:* Upland areas adjacent to the wetland are dominated by fill associated with commercial development and the SR 520 right-of-way.
- *Wetland determination:* In February 2013, SR 520 West Wetland was delineated and mapped based on topography and the corresponding fill associated with the adjacent development, upland vegetation and soils, and lack of hydrologic indicators. SR 520 West Wetland was identified as Wetland WR-11W in the *East Link Light Rail Project Final Environmental Impact Statement* (Sound Transit 2011). Fifty-four flags were

used to delineate the boundary of the wetland within the project area.

3.3.5.2 Valley Creek Wetland

- *Size and location:* Valley Creek Wetland is located in a narrow area between commercial development and SR 520, with 140th Avenue NE located to the west of the wetland (Appendix D, Frame 13). Valley Creek Wetland is associated with Valley Creek. Only a portion of Valley Creek Wetland was investigated due to lack of ROE. For this investigation, Anchor QEA performed a confirmation of the wetland boundary based on information from a previous delineation as identified in the *East Link Light Rail Project Final EIS* (Sound Transit 2011). The wetland was not flagged or surveyed as part of this investigation. The wetland may extend outside the project area to the south for a short distance along Valley Creek, between commercial development to the east and west; however, the available area between developments is only about 15 feet wide including the stream channel. Based on visual observations from within the project area, aerial photograph analysis, and the location of development features that would limit the extent of the wetland system, the approximate size of Valley Creek Wetland is 0.37 acre. Four sample plots were established during the investigation of Valley Creek Wetland (Appendices A and B).
- *Vegetation:* Dominant vegetation includes red alder, black cottonwood, Pacific willow, bittersweet nightshade, spirea, and water parsley, with horsetail, reed canarygrass, red-osier dogwood, and Himalayan blackberry also occurring (Appendices A and B).
- *Soils:* In one sample plot, the surface layer to about 7 inches deep was a very dark gray (10YR 3/1) sandy loam beneath about a 1 inch layer of duff/leaf litter. The second layer extends from about 7 to at least 18 inches deep, and is very dark gray (10YR 3/1) sand with dark yellowish brown (10YR 5/3) redox features (Appendices A and B). In the other sample plot the surface layer to about 7 inches deep was a very dark gray (10YR 3/1) loam. The second layer extends from about 7 to at least 18 inches deep, and is a gray (2.5Y 6/1) sandy loam with olive yellow (2.5Y 6/6) redox features (Appendices A and B).
- *Hydrology:* Saturation was present at the surface in both sample plots with the water table observed at 8 inches from the surface in one plot and absent to 18 inches in the

other sample plot. The wetland is associated with Valley Creek and culverts are located at the east end of the wetland.

- *Wetland classification:* Valley Creek Wetland is a small, narrow wetland with PFO, PSS, and PEM vegetation classes and riverine and slope HGM classes. The wetland soils are saturated and seasonally inundated and associated with a perennially flowing stream. Valley Creek Wetland is a Category II wetland under Ecology's rating system and the City of Bellevue's critical areas regulations (75-foot buffer).
- *Wetland function scores:* Valley Creek Wetland scores a moderate potential to improve water quality and provide opportunities to improve water quality (16 out of 32 possible maximum score). Valley Creek Wetland scores a moderate potential to reduce flooding and erosion and provides the opportunity to reduce flooding and erosion (18 out of 32 possible maximum score). The wetland scores a moderate potential and moderate opportunity (17 out of 36 possible maximum score) to provide habitat functions. Overall, the total Ecology wetland functions score for Valley Creek Wetland is 51 out of a possible 100.
- *Wetland adjacent land use:* Upland areas adjacent to the wetland are dominated by fill associated with commercial development and the SR 520 right-of-way.
- *Wetland determination:* In April 2013, Valley Creek Wetland was delineated and mapped based on topography and the corresponding fill associated with the adjacent development, upland vegetation and soils, and lack of hydrologic indicators. Valley Creek Wetland was identified as Wetland WR-10W in the *East Link Light Rail Project Final EIS* (Sound Transit 2011). As described above, Valley Creek Wetland was not flagged or surveyed as part of this investigation. Due to lack of ROE, the boundary was identified based on visual observations and information of the wetland from a previous delineation.

3.3.5.3 SR 520 East Wetland

- *Size and location:* SR 520 East Wetland is located in a narrow area between commercial development and SR 520 (Appendix D, Frames 13 and 14). Only the west portion of this wetland was investigated due to lack of ROE. For this investigation, Anchor QEA performed a confirmation of the eastern portion of the wetland based on information from a previous delineation, identified in the *East Link Light Rail*

Project Final EIS (Sound Transit 2011). The entire wetland boundary, including the delineated portion and the verified portion, is, approximately 0.23 acre. The entire wetland is located within the project area. Two sample plots were established during the delineation of SR 520 East Wetland (Appendices A and B).

- *Vegetation:* Dominant vegetation includes red alder, black cottonwood, Scouler's willow, lady fern, and skunk cabbage, with horsetail and Himalayan blackberry also occurring (Appendices A and B).
- *Soils:* The surface layer to about 7 inches deep was a very dark gray (10YR 3/1) loam. The second layer extends from about 7 to at least 18 inches deep, and is dark gray (10YR 4/1) loam with no redox features (Appendices A and B).
- *Hydrology:* Saturation was at the surface and standing water was present about 4 inches deep in the soil data pit (Appendices A and B). Culverts are located at the west and east ends of the wetland. SR 520 East Wetland is connected to Valley Creek Wetland to the west via a jurisdictional ditch (Section 5.2) that runs along the commercial development.
- *Wetland classification:* SR 520 East Wetland is a small, narrow wetland with PFO, PSS, and PEM vegetation classes and a slope HGM class. The wetland soils are saturated and seasonally inundated. SR 520 East Wetland is a Category III wetland under Ecology's rating system and the City of Bellevue's critical areas regulations (60-foot buffer).
- *Wetland function scores:* SR 520 East Wetland scores a moderate potential to improve water quality and provide opportunities to improve water quality (10 out of 24 possible maximum score). SR 520 East Wetland scores a moderate potential to reduce flooding and erosion and provide the opportunity to reduce flooding and erosion (10 out of 16 possible maximum score). The wetland scores a moderate potential and low opportunity (13 out of 36 possible maximum score) to provide habitat functions. Overall, the total Ecology wetland functions score for SR 520 East Wetland is 33 out of a possible 76.
- *Wetland adjacent land use:* Upland areas adjacent to the wetland are dominated by fill associated with commercial development and the SR 520 right-of-way.
- *Wetland determination:* In May 2013, SR 520 East Wetland was delineated and mapped based on topography and the corresponding fill associated with the adjacent development, upland vegetation and soils and lack of hydrologic indicators. SR 520

East Wetland was identified as Wetland WR-10E in the *East Link Light Rail Project Final Environmental Impact Statement* (Sound Transit 2011). Thirteen flags were used to delineate the boundary of SR 520 East Wetland within the project area.

3.4 Regulatory Framework

Guidance from USFWS, Ecology, and the City of Bellevue was used to determine the wetland classifications. Information and excerpts from the specific guidance language are provided below.

3.4.1 USFWS Classification, Stream Association, and Local Wetland Inventory

The wetlands identified in the project area were classified using the system developed by Cowardin et al. (1979) for use in the NWI. Table 6 lists the USFWS classifications for the wetlands, identifies any connections to surface waters, and shows if the wetlands are identified on local jurisdiction (Bellevue and Redmond) wetland maps.

Table 6
USFWS Wetland Classifications,
Surface Water Connections, and Local Wetland Maps

Wetland	USFWS Classification	Surface Water Association	Identified on Local Wetland Maps (Bellevue 2013b)
Mercer Slough	PFO, PSS, PEM, PAB	Mercer Slough, Stream A, and Stream B	Yes
Alcove Creek	PFO, PSS, PEM	Alcove Creek	Yes
Bellefield South	PFO, PSS, PEM	Mercer Slough	No
Bellefield North	PFO, PSS	Mercer Slough	No
8th Street	PFO, PSS, PEM	No	No
Lake Bellevue	PAB	Sturtevant Creek	Yes
South Lake	PFO, PSS, PEM	No	No
Central Lake	PSS, PEM	No	No
North Lake	PFO, PEM	No	No
BNSF Southwest	PFO, PEM	No	No
BNSF East	PEM	No	No
BNSF West	PFO, PSS, PEM	No	No
BNSF Northeast	PFO, PSS	No	No

Wetland	USFWS Classification	Surface Water Association	Identified on Local Wetland Maps (Bellevue 2013b)
BNSF Northwest	PFO, PEM	No	No
BNSF North	PFO, PSS	No	No
Kelsey West Tributary Pond	PFO, PEM	West Tributary Kelsey Creek	Yes
Kelsey West Tributary Stream	PFO, PSS, PEM	West Tributary Kelsey Creek	No
136th Place	PFO, PSS, PEM	No (no current evidence of flow, appears to be relic stream channel)	No
SR 520 West	PFO, PSS, PEM	No	No
Valley Creek	PFO, PSS, PEM	Valley Creek	No
SR 520 East	PFO, PSS, PEM	No	No

Notes:

PFO = palustrine forested

PSS = palustrine scrub-shrub

PEM = palustrine emergent

PAB = palustrine aquatic bed

USFWS = U.S. Fish and Wildlife Service

3.4.2 Wetland Classifications and Ratings

Wetland ratings are determined at the state level, using Ecology’s *Washington State Wetland Rating System for Western Washington: Revised* (Hruby 2004) and *Washington State Wetland Rating Form – Western Washington, Version 2* (Ecology 2008). Wetlands are also rated using the Ecology wetland rating system under local jurisdiction codes for the cities of Bellevue (Bellevue 2013a) and Redmond (Redmond 2013a). Under the Ecology system, of the 21 wetlands identified within the project area, there are six Category II wetlands, 13 Category III wetlands, and two Category IV wetlands.

As described in Section 3.1.6, the Ecology system defines which HGM classification to use in the rating process when multiple HGM classifications are present. Table 7 lists the Ecology and local (Bellevue) wetland ratings and classifications. Ecology wetland rating forms are included in Appendix C.

Table 7
Summary of Ecology and Local Wetland Classifications and Ratings

Wetland	Hydrogeomorphic Classifications	State and Local Rating¹ (Ecology and Bellevue)	Wetland Characteristics Buffer Criteria	Buffer Width (feet)
Mercer Slough	Depressional ² , Lake-Fringe, Riverine, Slope	II	Habitat Score 20 to 28	110
Alcove Creek	Depressional ² , Riverine	II	Habitat Score < 20	75
Bellefield South	Riverine ² , Slope	II	Habitat Score < 20	75
Bellefield North	Riverine ² , Slope	II	Habitat Score < 20	75
8th Street	Depressional ²	III	Habitat Score < 20	60
Lake Bellevue	Depressional ²	III	Habitat Score < 20	60
South Lake	Depressional ²	III	Habitat Score < 20	60
Central Lake	Depressional ²	III	Habitat Score < 20	60
North Lake	Slope ²	IV	< 2,500 sf	0
BNSF Southwest	Depressional ² , Slope	III	Habitat Score < 20	60
BNSF East	Depressional ²	III	Habitat Score < 20	60
BNSF West	Depressional ² , Slope	III	Habitat Score < 20	60
BNSF Northeast	Depressional ²	III	Habitat Score < 20	60
BNSF Northwest	Depressional ² , Slope	IV	> 2,500 sf	40
BNSF North	Depressional ² , Slope	III	Habitat Score < 20	60
Kelsey West Tributary Pond	Depressional ² , Riverine	II	Habitat Score < 20	75
Kelsey West Tributary Stream	Riverine ²	III	Habitat Score < 20	60
136th Place	Depressional ²	III	Habitat Score < 20	60
SR 520 West	Depressional ² , Slope	III	Habitat Score < 20	60
Valley Creek	Riverine ² , Slope	II	Habitat Score < 20	75
SR 520 East	Slope ²	III	Habitat Score < 20	60

Notes:

- 1 Ecology and Bellevue ratings are the same
- 2 Hydrogeomorphic classification used for the rating

3.4.3 Wetland Buffer Requirements

Appropriate minimum wetland buffers were identified according to the current BCC (Bellevue 2013a) and RMC (Redmond 2013a). The BCC and RMC identify minimum protective buffer widths based on the wetland category, per the Ecology rating system, the existing land use within the prescribed buffer, and the Ecology function scores for habitat. Bellevue and Redmond will determine the final wetland ratings and minimum buffers. Wetland buffer widths based on the local rating are identified in Table 7.

3.4.4 Wetland Functions and Values Summary

In general, wetlands in the project area provide many functions, including water quality improvements, floodwater storage, groundwater recharge, and wildlife habitat. However, wetlands in the project area are typically located in low-lying areas adjacent to roads or other development features and have been disturbed by human influence to some extent. Consequently, these wetlands are compromised in their ability to provide these functions.

Based on the rating scores, the overall functions of each of the three wetland rating categories of water quality, hydrologic, and wildlife habitat are rated as low (less than 34 percent of the possible maximum score), moderate (34 percent to 67 percent of the possible maximum score), or high (greater than 68 percent of the possible maximum score). Overall, the majority of wetlands in the project area have moderate water quality, hydrologic, and wildlife habitat function scores. Few of the wetlands have high water quality, hydrologic, or wildlife habitat function scores. Of the 21 wetlands in the project area, 15 were rated as depressional wetlands, two were rated as slope wetlands, and four were rated as riverine wetlands. Ecology wetland rating forms for wetlands in the East Link Extension Project area are provided in Appendix C. Water quality, hydrologic, and habitat functional value scores for wetlands in the project area are shown in Table 8.

Table 8
Summary of Functions and Values Wetland Rating Scores

Wetland	Water Quality Functions Potential Score	Water Quality Functions Opportunity (Yes/No)	Hydrologic Functions Potential Score	Hydrologic Functions Opportunity (Yes/No)	Habitat Functions Potential Score	Habitat Functions Opportunity Score	Total Functions Score ¹
Depressional and Riverine Maximum Scores	16	No = 1 Yes = 2	16	No = 1 Yes = 2	18	18	100
Mercer Slough	10	Yes	10	No	17	10	57
Alcove Creek	7	Yes	10	Yes	11	8	53
Bellefield South	10	Yes	8	Yes	10	8	54
Bellefield North	10	Yes	8	Yes	9	8	53
8th Street	3	Yes	12	Yes	6	5	41
Lake Bellevue	2	Yes	16	Yes	5	7	30
South Lake	7	Yes	8	Yes	8	5	43
Central Lake	5	Yes	10	Yes	7	4	41
BNSF Southwest	7	Yes	8	Yes	8	4	42
BNSF East	7	Yes	8	Yes	3	4	37
BNSF West	7	Yes	8	Yes	8	4	42
BNSF Northeast	7	Yes	8	Yes	6	4	40
BNSF Northwest	4	Yes	3	Yes	6	4	24
BNSF North	7	Yes	8	Yes	6	4	40
Kelsey West Tributary Pond	22	Yes	24	Yes	17		63
Kelsey West Tributary Stream	8	Yes	9	Yes	9	7	50
136th Place	5	Yes	10	Yes	6	4	40
SR 520 West	9	Yes	8	Yes	9	5	48
Valley Creek	8	Yes	9	Yes	10	7	51
Slope Maximum Scores	12	No = 1 Yes = 2	8	No = 1 Yes = 2	18	18	76
North Lake	4	Yes	2	Yes	6	4	22
SR 520 East	5	Yes	5	Yes	9	4	33

Notes:

1 Total functions score calculated as:

$$(Q \times R) + (S \times T) + U + V = W$$

Where:

Q = Water Quality Functions Potential Score

R = Water Quality Opportunity Score

S = Hydrologic Functions Potential Score

T = Hydrologic Functions Opportunity Score

U = Habitat Functions Potential Score

V = Habitat Functions Opportunity Score

W = Total functions score

2 Habitat Function potential/opportunity scores are combined due to unavailable data sheets (Parametrix 2012).

Wetland acreage also affects the performance of wetland function (Hruby et al. 1999). Large wetlands are more likely to provide more beneficial functions than smaller wetlands, because they have more capacity for capturing stormwater flows, improving water quality, and providing a variety of habitats for wildlife. Water quality, hydrologic, and habitat functional values for wetlands in the project area are described below. For each function category, the wetlands' potential to provide that function is described first, and the wetlands' opportunity to provide that function is described subsequently.

3.4.4.1 Water Quality Functions

All of the wetlands in the project area provide opportunities to improve water quality, to varying degrees, primarily because their location in an urban environment allows the opportunity for water quality improvement. Six of the 21 wetlands (29 percent) have a low potential (less than 34 percent of the possible maximum score) to improve water quality due to their association with roadside drainage ditches with culverts or catch basins that provide unconstricted or slightly constricted surface outlets. Minimal or no seasonal ponding occurs within these six wetlands. Fourteen of the 21 wetlands (67 percent) have moderate potential scores (34 to 67 percent of the possible maximum score) to improve water quality. One wetland (5 percent), Kelsey West Tributary Pond Wetland, has high potential to improve water quality (greater than 68 percent of the possible maximum score). Wetlands with moderate or high scores typically have characteristics such as a high proportion of wetland area with seasonal ponding, or dense vegetation to restrict flow through the wetland.

3.4.4.2 Hydrologic Functions

All of the wetlands in the project area provide opportunities to reduce flooding and erosion, to varying degrees, with the exception of Mercer Slough Wetland. Mercer Slough Wetland lacks the opportunity to reduce flooding or erosion because of the wetland is associated with Lake Washington, which has water levels that are controlled by the Corps at the Ballard Locks. Three of the 21 wetlands (14 percent) in the project area have a low potential (less than 34 percent of the possible maximum score) to reduce flooding and erosion. The low scores for potential hydrologic functions are due to a lack of natural surface water outlets, ponding features, and the types of vegetation to reduce surface flows; a high presence of ditch - like characteristics; and small contribution of the wetlands to the larger watershed.

Sixteen of the wetlands (76 percent) have moderate potential scores (34 percent to 67 percent of the possible maximum score). The remaining two wetlands (10 percent), 8th Street and Kelsey West Tributary Pond wetlands, have high function scores for the potential to improve hydrologic functions (greater than 68 percent of the possible maximum score). Wetlands with moderate or high scores typically have characteristics such as a highly constricted outlets or significant water storage depths during wet periods.

3.4.4.3 *Habitat Functions*

Habitat functions of the wetlands are further defined by their Cowardin classification (e.g., PFO, PEM, and PSS). Of the 21 wetlands in the project area, one wetland was classified as a PEM wetland; one wetland was classified as a PSS and PEM system; three of the wetlands include PFO and PEM systems; three of the wetlands include PFO and PSS systems; ten of the wetlands include PFO, PSS, and PEM systems; two of the wetlands include PFO, PSS, PEM, and PAB systems; and one of the wetlands was a PAB only system (Table 6). Wetlands with mixed classifications are generally of higher value than wetlands with a single classification. PFO wetlands are generally considered to be of higher value than PEM or PSS wetlands because of the functional values they provide.

Seven of the 21 wetlands (33 percent) have a low potential (less than 34 percent of the possible maximum score) to provide habitat for many species. The low score for habitat functions is due to the general lack of vegetative structure, hydroperiods, plant richness, habitat diversity, and special habitat features. Eleven (52 percent) of the wetlands had a moderate score (34 to 67 percent of the possible maximum score) and three wetlands (14 percent) had a high score (greater than 68 percent of the possible maximum score). Wetlands with moderate or high scores typically have characteristics such as a several Cowardin vegetation classes, several hydroperiods, high habitat interspersion, or the presence of special habitat features. Fourteen of the 21 wetlands (66 percent) have a low opportunity (less than 34 percent of the possible maximum score) to provide habitat for many species. The low score for habitat opportunity is due to the characteristics of the wetland buffers and the overall lack of quality habitat conditions near or adjacent to the wetlands, including their proximity to roads. In addition to the wetlands being located near roads, the wetlands are often located near residential or commercial development. The

remaining seven wetlands (33 percent) have a moderate potential score (34 to 67 percent of the possible maximum score). The wetlands with moderate scores have relatively undisturbed buffer areas. No wetlands in the project area have high function scores for the potential to provide habitat.

3.5 Wetland Delineation and Typing Limitations

Wetland identification is an inexact science, and differences of professional opinion often occur between trained individuals. Final determinations for wetland boundaries and typing concurrence or adjustments to these are the responsibility of the regulating resource agency. Wetlands are, by definition, transitional areas; their boundaries can be altered by changes in hydrology or land use. In addition, the definition of jurisdictional wetlands may change. If a physical change occurs in the basin, or if approximately 3 to 5 years pass before the proposed project is undertaken (based on varying agency requirements), another wetland survey should be conducted. The results and conclusions expressed herein represent Anchor QEA's professional judgment based on the information available. No other warranty, expressed or implied, is made.

4 STREAM ORDINARY HIGH WATER MARK DELINEATION

The OHWM of ten stream systems was identified and delineated within the project area. Only OHWM delineations were performed as part of this analysis. Only stream OHWM delineations were performed as part of this analysis; information such as stream features and functions and associated riparian conditions was not collected as part of the investigation. The OHWM delineation methods are presented in Section 4.1. Results of the stream OHWM delineation are provided in Section 4.2. OHWM delineation results are shown on the figures provided in Appendix D.

4.1 Ordinary High Water Mark Delineation Methods

To document the OHWM of the streams within the project area, existing information was reviewed (described in Section 2.1.1), and an aerial photograph analysis was performed, followed by site visits in February, March, April, and May 2013. The OHWM delineations were completed by walking the stream shorelines and identifying the OHWM with flagging. The location of flagging was documented on aerial photographs and the locations were provided to the survey team to assist the survey team in locating the flags. The OHWM boundaries were typically marked with flags in parallel formation on both banks, as in LB-1 (left bank) and RB-1 (right bank), LB-2 and RB-2, etc. In cases where the stream channel was very narrow, usually less than about 2 feet wide, the center line of the stream was flagged for survey and documented the average width. In addition, in cases where ROE conditions stipulated that survey flags not be used, OHWM data was collected with a GPS unit.

4.1.1 State OHWM Delineation Regulations

The stream OHWM boundaries were identified consistent with Chapter 90.58 of the Revised Code of Washington (RCW) and Chapter 173-22 of the Washington Administrative Code (WAC). The WAC provides the following definition:

“Ordinary high water line” means the mark on the shores of all waters that will be found by examining the bed and banks and ascertaining where the presence and action of waters are so common and usual and so long continued in ordinary years, as to mark upon the soil or vegetation a character distinct from that of the abutting upland: Provided, that in any area where the ordinary high water line

cannot be found the ordinary high water line adjoining saltwater shall be the line of mean higher high water and the ordinary high water line adjoining freshwater shall be the elevation of the mean annual flood.

Guidance and policy documents from WDFW and Ecology use OHWM and “ordinary high water line” interchangeably; this report uses OHWM.

4.1.2 Local Jurisdictions Stream Rating System and Buffer Requirements

The types of streams in the project area were determined according to the local jurisdiction’s critical areas ordinances that establish local regulatory requirements for streams and their associated buffers. Local jurisdictions occurring within the project area include the cities of Bellevue and Redmond. All 11 of the stream systems identified during the investigation are located within the City of Bellevue, and no streams were identified within the City of Redmond. Therefore, no additional information on Redmond’s regulation of streams and associated buffers is included in this stream section. Streams in the project area were assigned with a classification and associated stream buffer widths were identified based on the applicable city code regulations.

The following sections extract stream information contained in the BCC (Bellevue 2013a). The full text of the City of Bellevue’s critical areas regulations was consulted during the analysis.

4.1.2.1 City of Bellevue

The BCC Chapter 20.25H.075.A classifies streams into four categories (Types S, F, N, and O) that are defined as follows:

- Type S water means all waters, other than shoreline critical areas designated under Land Use Code 20.25E.017, within their bankfull width, as inventoried as “shorelines of the state” under Chapter 90.58 RCW and the rules promulgated pursuant to Chapter 90.58 RCW, including periodically inundated areas of their associated wetlands.
- Type F water means all segments of waters that are not Type S waters, and that contain fish or fish habitat, including waters diverted for use by a federal, state, or

tribal fish hatchery from the point of diversion, for 1,500 feet or the entire tributary, if the tributary is highly significant for protection of downstream water quality.

- Type N water means all segments of waters that are not Type S or F waters and that are physically connected to Type S or F waters by an aboveground channel system, stream, or wetland.
- Type O water means all segments of waters that are not Type S, F, or N waters and that are not physically connected to Type S, F, or N waters by an aboveground channel system, stream, or wetland.

According to the City of Bellevue Land Use Code (LUC), stream buffers shall be established from the stream Top of Bank, as summarized in Table 9. The LUC defines “Top of Bank” as, “the point closest to the boundary of the active floodplain of a stream where a break in the slope of the land occurs such that the grade beyond the break is flatter than 3:1 at any point for minimum distance of 50 feet measured perpendicularly from the break; and for a floodplain area not contained within a ravine, the edge of the active floodplain of a stream where the slope of the land beyond the edge is flatter than 3:1 at any point for a minimum distance of 50 feet measured perpendicularly from the edge” (Bellevue 2013c).

Table 9
City of Bellevue Stream Buffer Regulations

Stream Category	Buffer Width (feet)
Type S	100
Type F	100
Type N	50
Type O	25

Note:

Source: Bellevue 2013a, Chapter 20.25H.075.C.1.a

4.2 Stream Ordinary High Water Mark Results

Project ecologists identified ten streams within the project area, as defined in Section 2.3. The project area spans an approximate cumulative length of 7.13 miles (Figure 1) and contains nine drainage basins within the Cedar/Sammamish Watershed (WRIA 8) (Ecology 2013). The nine basins, in order from west to east along the project alignment, include

Beaux Arts, Mercer Slough, Sturtevant Creek, West Tributary, Goff Creek, Kelsey Creek, Valley Creek, Sears Creek, and Lake Sammamish (Bellevue 2013b and Redmond 2013b). The first seven basins are located within Bellevue. The eighth basin, Sears Creek, is located within the city limits of both Bellevue and Redmond. The ninth basin, Lake Sammamish, is located within the city limits of Redmond. Drainage basins are shown on Figure 2. Stream OHWM delineation results are shown on the figures in Appendix D. The stream areas shown represent the total length of OHWM delineated. Table 10 presents a summary of the streams in the project area, approximate stream OHWM length, and the stream’s drainage basin.

Table 10
Summary of Streams Located within the Project Area

Stream	OHWM Length ¹ (feet)	Drainage Basin ²
Stream A	260	Mercer Slough
Stream B	83	Mercer Slough
Wye Creek	150	Mercer Slough
Alcove Creek	226	Mercer Slough
Sturtevant Creek	689	Sturtevant Creek
West Tributary to Kelsey Creek	321	West Tributary
Stream C	291	West Tributary
Goff Creek	61	Goff Creek
Unnamed Tributary to Kelsey Creek	342	Kelsey Creek
Valley Creek	205	Valley Creek

Notes:

1 Calculations provided by HJH for open channel areas that were delineated

2 Bellevue 2013b; Redmond 2013b

OHWM = ordinary high water mark

4.3 Stream Ordinary High Water Mark Descriptions

The 11 systems with OHWM delineated in the project area are described in the following sections, and stream OHWM descriptions are grouped into the representative drainage basin (Figure 2). Since no streams were identified within three of the basins (Beaux Arts, Sears Creek, and Lake Sammamish), these basins are not included in the following sections.

Within each drainage basin, stream OHWM is described in location sequence from west to east. Each stream in the project area was assigned a name based on the basin in which it occurs and the name used in past reports.

4.3.1 Mercer Slough Basin

The OHWM of four streams within the Mercer Slough basin was delineated within the project area: two Type F streams (Alcove Creek and Wye Creek), and two Type N streams (Stream A and Stream B). Within this basin, the project area generally extends from I-90 and about 110th Avenue SE to about 112th Avenue SE and SE 8th Street (Figure 2). Streams in the Mercer Slough basin are summarized on Table 10 and shown on the figures in Appendix D, Frames 2, 4, and 5.

4.3.1.1 Stream A

The OHWM of an unnamed stream system identified as Stream A within the project area was delineated (Appendix D, Frame 4). One of the wetlands delineated as part of the investigation, Mercer Slough Wetland, is associated with Stream A (Section 3.3).

Stream A flows from wetland seeps near 112th Avenue SE and the western edge of the Mercer Slough Wetland complex (Section 3.3). The stream flows outside the project area to the east. Based on observations during the field investigation and an analysis of aerial photographs, Stream A appears to drain into the Mercer Slough Wetland complex. Within the project area, Stream A averaged about 1 to 3 feet wide and ranged from about 1 to 10 inches deep at the time of the investigation. The stream channel is located within the wetland habitat of the Mercer Slough Wetland. The banks are less than 1 foot high from the stream bottom and are not clearly defined, flowing through saturated soil conditions and small areas of standing water. The riparian vegetation is very dense and dominated by species such as salmonberry, red alder, and willow. Dominant substrate in the channel consists of a mixture of fine-textured sediment of silt and sand. Small gravels and large gravels and cobbles are rare within the channel. Small and large branches of woody debris are present on the ground, crossing the narrow channel at the top of the banks above the water line.

An approximately 260-foot reach of Stream A was delineated within the project area. The Stream A OHWM delineation results are shown in Appendix D, Frame 4. Stream A appears to meet the criteria of a Type N water under the City of Bellevue's critical areas regulations (50-foot buffer), physically connected to Type S or F waters (Mercer Slough) by an aboveground channel system, stream, or wetland. Stream A is not identified on City of Bellevue critical area maps (Bellevue 2013b) or WDFW Priority Habitats and Species (PHS) maps (WDFW 2013a).

4.3.1.2 *Stream B*

The OHWM of an unnamed stream system, identified as Stream B, within the project area was delineated (Appendix D, Frame 4). Stream B is associated with Mercer Slough Wetland (Section 3.3).

Stream B flows east from wetland seeps near 112th Avenue SE and the western edge of the Mercer Slough Wetland (Section 3.3). Stream B flows into Stream A within the project area. Within the project area, Stream B averaged about 1 to 2 feet wide and ranged from about 1 to 6 inches deep at the time of the investigation. The stream channel is located within the habitat of the Mercer Slough Wetland. The banks are less than about 10 inches high from the stream bottom and are not clearly defined, flowing through saturated soil conditions and small areas of standing water. The riparian vegetation is very dense and dominated by species such as salmonberry, red alder, and willow. Dominant substrate in the channel consists of a mixture of fine-textured sediment of silt and sand. Small and large gravels and cobbles are rare within the channel. Small and large branches of woody debris are present on the ground, crossing the narrow channel at the top of the banks above the water line.

An approximately 83-foot reach of Stream B was delineated within the project area. Stream B appears to meet the criteria of a Type N water under the City of Bellevue's critical areas regulations (50-foot buffer), physically connected to Type S or F waters (Mercer Slough) by an aboveground channel system, stream, or wetland. Stream B is not identified on City of Bellevue critical area maps (Bellevue 2013b) or WDFW PHS maps (WDFW 2013a).

4.3.1.3 *Wye Creek*

The OHWM of an unnamed stream system identified as Wye Creek was confirmed within the project area (Appendix D, Frame 4).

Wye Creek flows east from a pair of culverts located under the split at Bellevue Way and 112th Avenue SE. The stream was originally characterized as a wetland, but it was delineated as a stream during field investigations. Wye Creek flows east and drains into the Mercer Slough Wetland complex. Within the project area, Wye Creek averaged about 3 to 6 feet wide and ranged from about 6 to 24 inches deep at the time of the investigation. The banks are deeply incised, and the top of the bank is more than 3 feet above the water line in some areas. The banks showed evidence of scouring, indicating high flow conditions during storm events. Dominant substrate in the channel consists of a mixture of fine-textured sediment of silt, sand, and small gravels. Large gravels and cobbles are present in patches within the channel. Riparian vegetation is dominated by a dense canopy of native trees and shrubs, with nonnative Himalayan blackberry occasionally present. Small and large branches of woody debris are present within the channel and crossing at the top of the banks a few feet above the water line.

An approximately 150-foot reach of Wye Creek flows within the project area. The Wye Creek OHWM delineation results are shown in Appendix D, Frame 4. Wye Creek appears to meet the criteria of a Type F rating under the City of Bellevue's critical areas regulations (100-foot buffer), physically connected to Type S waters (Mercer Slough) by an aboveground channel system, stream, or wetland. Wye Creek is not identified on City of Bellevue critical area maps (Bellevue 2013b) or WDFW PHS maps (WDFW 2013a).

4.3.1.4 *Alcove Creek*

The OHWM of an unnamed stream system within the project area was delineated and identified as Alcove Creek (Appendix D, Frame 5). One of the wetlands delineated as part of the investigation, Alcove Creek Wetland, is associated with Alcove Creek (Section 3.3).

Alcove Creek flows southeast from a ponded area and a wetland within residential development. A second pond is located upstream of the first pond located outside the project

area. The upstream location of the stream is located outside the project area boundary and was not identified during the investigation. Alcove Creek flows to the southeast through a culvert under 112th Avenue SE. There is no open water reach of Alcove Creek east of 112th Avenue SE where the stream falls into the west side of Mercer Slough from a hanging culvert. Alcove Creek is identified as ending at the culvert beneath 112th Avenue SE. East of the culvert Alcove Creek becomes part of the Mercer Slough Wetland system. The project drainage team identified an artificial hydrology source, which pumps water from Mercer Slough to the upper pond.

An approximately 226-foot reach of Alcove Creek was delineated within the project area. Within the project area, Alcove Creek averaged about 2 to 6 feet wide and ranged from about 2 to 10 inches deep at the time of the investigation. Bank conditions are not clearly defined in some areas, indicating frequent overbank flooding and variations in flow during storm events. Dominant substrate in the channel consists of a mixture of fine-textured sediment of silt, sand, and small gravels. Large gravels and cobbles are rare. Riparian vegetation includes a mixture of native trees such as black cottonwood, and willow, nonnative vegetation such as Himalayan blackberry and mowed grass associated with residential development. Small and large branches of woody debris are very dense within the channel, accumulating at the culvert at the downstream end of the channel.

Alcove Creek appears to meet the criteria of Type F waters under the City of Bellevue's critical areas regulations (100-foot buffer), physically connected to Type S waters (Mercer Slough) by an aboveground channel system, stream, or wetland. Alcove Creek is not identified on City of Bellevue critical areas maps (Bellevue 2013b) or WDFW PHS maps (WDFW 2013a).

4.3.2 *Sturtevant Creek Basin*

The OHWM of one stream, within the Sturtevant Creek basin was delineated in the project area. Sturtevant Creek is a Type F stream. Within this basin, the project area generally extends from about 112th Avenue SE and SE 8th Street to about 120th Avenue NE and NE 12th Street (Figure 2). The stream in the Sturtevant Creek basin is shown on Table 10 and in Appendix D, Frame 9.

4.3.2.1 *Sturtevant Creek*

The OHWM of Sturtevant Creek was delineated within the project area (Appendix D, Frame 9). Within the project area, Sturtevant Creek flows from Lake Bellevue south along the former BNSF railway for approximately 600 feet before flowing through another approximately 35-foot-long culvert located beneath railroad tracks. The stream then flows west for approximately 20 feet before flowing into a culvert to the west near I-405 (Appendix D, Frame 9). Sturtevant Creek passes under I-405 through an approximately 250-foot culvert located 700 feet south of Main Street.

An approximately 689-foot reach of Sturtevant Creek was delineated within the project area. Within the project area, Sturtevant Creek is a linear channel with almost no sinuosity. The channel averaged about 3 to 6 feet wide and ranged from about 6 to 18 inches deep at the time of the investigation. The banks are almost vertical and deeply incised, and the top of bank is more than 2 feet above the water line through most of the reach. The banks show evidence of scouring, indicating high flow conditions during storm events. Dominant substrate in the channel consists of a mixture of fine-textured sediment of silt, sand, and small gravels. Large gravels and cobbles are infrequent within the channel. Angular rock was observed within the channel associated with fill material present on both banks. Riparian vegetation at the south end of the channel is dominated by nonnative shrubs such as Himalayan blackberry and Scot's broom, grass, and weedy herbaceous species. Red alder and black cottonwood trees are present at the north end of the channel near Lake Bellevue. The riparian zone is very narrow, with development located to the east and railroad tracks located to the west side of the channel. Woody debris within the channel is rare. Significant litter accumulation was present within the channel at the time of the investigation.

Sturtevant Creek is identified as a Type F water on City of Bellevue critical area maps (Bellevue 2013b). Under the City of Bellevue's critical areas regulations, Type F waters have a 100-foot protective buffer. This reach of Sturtevant Creek is not identified on WDFW PHS maps (WDFW 2013a).

4.3.3 West Tributary Basin

The OHWM of two streams within the West Tributary basin was delineated within the project area: West Tributary to Kelsey Creek, a Type N stream; and Stream C, a Type O stream. Within this basin, the project area generally extends from about 112th Avenue SE and SE 8th Street to about 120th Avenue NE and NE 12th Street (Figure 2). Streams in the West Tributary basin are summarized on Table 10 and shown in Appendix D, Frames 11 and 12.

4.3.3.1 West Tributary to Kelsey Creek

The OHWM of the West Tributary to Kelsey Creek was within the project area (Appendix D, Frame 11). This stream is associated with the Kelsey West Tributary Stream Wetland (Section 3.3).

Within the project area, the West Tributary to Kelsey Creek flows southeast and then south from a culvert located beneath a large reinforced weir. Upstream of the OHWM delineation the stream flows through the Kelsey West Tributary Pond Wetland. The stream flows into a culvert at the downstream end of the OHWM delineation (Appendix D, Frame 11). An approximately 321-foot reach of the stream was delineated within the project area. Within the project area, the West Tributary to Kelsey Creek channel is linear with very little sinuosity. The channel averages about 4 to 8 feet wide and ranges from about 2 to 18 inches deep at the time of the investigation. The banks are vertical and the top of the bank is more than 3 feet above the water line through most of the reach. The banks show evidence of scouring, indicating high flow conditions during storm events. Dominant substrate in the channel consists of a mixture of fine-textured sediment of silt, sand, and small gravels. Large gravels and cobbles are present in patches within the channel. Angular rock is observed within the channel associated with fill material present on both banks. Riparian vegetation at the south end of the channel is dominated by the nonnative shrub Himalayan blackberry, with red alder, willow, grass, and weedy herbaceous species also present. The riparian zone is very narrow, with development located near the top of both banks. Small and large woody debris associated with alder and willow is present within the channel. Litter accumulation was present within the channel at the time of the investigation. An approximately 40-foot-wide weir is located at the downstream end of the stream, which controls flow in the stream

and is a contributing factor for the standing water present in the Kelsey West Tributary Pond Wetland system.

The West Tributary to Kelsey Creek appears to meet the criteria of Type F waters under the City of Bellevue's critical areas regulations (100-foot buffer), and is physically connected to Type S waters (Kelsey Creek) by an aboveground channel system, stream, or wetland. This reach is not identified on WDFW PHS maps (WDFW 2013a).

4.3.3.2 *Stream C*

The OHWM of an unnamed stream system was delineated within the project area, identified as Stream C (Appendix D, Frames 11 and 12). Based on aerial photograph analysis, this system appears to be an unnamed tributary to the West Tributary to Kelsey Creek.

Within the project area, Stream C flows west and into a culvert at the upstream and downstream reaches. The culverts are located beneath commercial development near the project area. An approximately 291-foot reach of Stream C was delineated within the project area. Within the project area, Stream C averaged about 2 to 3 feet wide and ranged from about 2 to 18 inches deep at the time of the investigation. Bank conditions are not clearly visible throughout most of the reach due to dense growth of grass and herbaceous vegetation covering the channel. Dominant substrate in the channel consists of a mixture of fine-textured sediment of silt, sand, and small gravels. Large gravels and cobbles are rare. Riparian vegetation is dominated by grass and herbaceous species. Tree and shrub vegetation is present on the hillside north of the channel but does not extend to the channel bank for most of the reach. Woody debris is rare within the channel.

Stream C discharges into West Tributary to Kelsey Creek via a culvert. The upstream source of Stream C could not be identified during the field investigation. Based on aerial photograph analysis, an exposed reach of the stream is not present within at least two blocks, and the stream is piped for an unidentified distance upstream. Stream C appears to meet the criteria of a Type O water under the City of Bellevue's critical areas regulations (25-foot buffer), not physically connected to Type S, F, or N waters by an aboveground channel

system, stream, or wetland. Stream C is not identified on City of Bellevue critical areas maps (Bellevue 2013b) or WDFW PHS maps (WDFW 2013a).

4.3.4 Goff Creek Basin

The OHWM of one stream within the Goff Creek basin within the project area was delineated and identified as Goff Creek, a Type F stream. Within the project area, this basin generally extends along NE 16th Street from an area between 130th Avenue NE and 132nd Avenue NE to approximately 136th Place NE (Figure 2). Streams in the Goff Creek basin are summarized on Table 10 and shown in Appendix D, Frame 12.

4.3.4.1 Goff Creek

Anchor QEA staff delineated the OHWM of Goff Creek within the project area. Upstream of the project area, Goff Creek flows south and southeast through an open channel. At the downstream end of the delineated reach, Goff Creek flows east through a culvert located beneath 132nd Avenue NE (Appendix D, Frame 12). An approximately 61-foot reach of Goff Creek was delineated within the project area. Within the Project area, Goff Creek averaged about 3 to 5 feet wide and ranged from about 4 to 14 inches deep at the time of the investigation. Banks are clearly defined, and the top of the bank ranges from 2 to 3 feet above the water line. Riprap for erosion control is a component of the bank structure. Dominant substrate in the channel consists of a mixture of silt, sand, small and large gravels, and cobbles. Riparian vegetation is dominated by narrow patches of native and ornamental tree and shrub landscape vegetation associated with the adjacent commercial development and public sidewalk. Woody debris is rare within the channel.

The Goff Creek OHWM delineation results are shown in Appendix D, Frame 12. Goff Creek is identified as a Type F water on City of Bellevue critical areas maps (Bellevue 2013b). Under the City of Bellevue's critical areas regulations, Type F waters have a 50- or 100-foot protective buffer, depending on site conditions, a developed or undeveloped site. A developed site is defined as a site with a primary structure. Because the reach of Goff Creek within the project area is located within commercial development, site conditions indicate a 50-foot protective buffer is applicable for Goff Creek (Bellevue 2013b). This reach of Goff Creek is not identified on WDFW PHS maps (WDFW 2013a).

4.3.5 Kelsey Creek Basin

Anchor QEA staff delineated the OHWM of one stream within the project area within the Kelsey Creek basin: Unnamed Tributary to Kelsey Creek, which is a Type N stream. Within this basin, the project area generally extends from about 130th Avenue NE and NE 15th Place to about NE 20th Street and 136th Place NE (Figure 2). The stream in the Kelsey Creek basin is summarized on Table 10 and shown on Appendix D, Frame 13.

4.3.5.1 Unnamed Tributary to Kelsey Creek

Anchor QEA staff delineated the OHWM of the Unnamed Tributary to Kelsey Creek, within the project area (Appendix D, Frame 13).

Within the project area the Unnamed Tributary to Kelsey Creek flows southwest from a culvert located beneath a commercial development parking lot (Appendix D, Frame 13). The first reach of the stream is part of a heavily planted mitigation site adjacent to a city side walk and a parking lot. The stream channel has no defined bed and bank due to dense vegetation, but flow within the vegetation was observed. The second reach is in a channelized ditch that flows southeast into a double culvert and into a City of Bellevue storm drain system. No downstream reaches of the stream were delineated within the project area. An approximately 250-foot reach of the stream was delineated within the project area. The east side of the channel is within the right-of-way of 136th Place NE. Within the project area, the Unnamed Tributary to Kelsey Creek stream averaged about 2 to 6 feet wide and ranged from about 4 to 18 inches deep at the time of the investigation. The stream channel has no defined bed and bank due to dense vegetation, but flow within the vegetation was observed.

Since the time of the field investigation, additional information on the Unnamed Tributary to Kelsey Creek was obtained. The second reach is in a channelized ditch that flows south into a double culvert. The stream then either flows into a 24-inch pipe within the City storm drain system located within 136th Place or into downstream reaches of the stream on the opposite side of 136th Place. The 24-inch pipe was originally constructed by the City in 1996 as an overflow pipe to address flooding issues. Over time, siltation in the system has raised the stream bed so that the overflow pipe is now the preferential flow path for the

stream. Flow still appears to get across 136th either through a City culvert (unable to field locate) or through the roadway subgrade. Results of numerous field visits and discussion with City staff indicate that the overflow pipe receives the majority of the flow from upstream, with a much smaller percentage making it across 136th and into the downstream open channel. The overflow pipe empties into the existing stream channel approximately 1,050 linear feet downstream of the 136th Street Crossing.

Riparian vegetation in the second reach is mowed grass. Dominant substrate in the channel consists of a mixture of fine-textured sediment of silt, sand, and small gravels. Large gravels and cobbles were rare. Angular rock is present within the channel. Woody debris is absent within the channel.

The Unnamed Tributary to Kelsey Creek is identified as a Type N water on City of Bellevue critical areas maps (Bellevue 2013b). Under the City of Bellevue's critical areas regulations, Type N waters have a 50-foot protective buffer. The reach of the Unnamed Tributary to Kelsey Creek is not identified on WDFW PHS maps (WDFW 2013a).

4.3.6 Valley Creek Basin

Anchor QEA staff confirmed the OHWM of one stream within the project area within the Valley Creek basin: Valley Creek, which is a Type N stream. Within this basin, the project area generally extends from about 140th Avenue NE and NE 24th Street to SR 520 (Figure 2). The stream in the Valley Creek basin is summarized on Table 10 and shown on Appendix D, Frame 13.

4.3.6.1 Valley Creek

The OHWM of Valley Creek was confirmed within the project area (Appendix D, Frame 13). One of the wetlands delineated as part of the investigation, Valley Creek wetland, is associated with Valley Creek (Section 3.3).

Valley Creek flows south from two approximately 36-inch culverts located under SR 520, and then flows south to a weir structure at NE 21st Street (Appendix D, Frame 13). Valley Creek flows through the Valley Creek Wetland and is a tributary to Kelsey Creek. Within

the project area, Valley Creek averaged about 7 to 10 feet wide and ranged from about 12 to 36 inches deep at the time of the investigation. Within the project area, riparian vegetation in the upstream reach includes trees and shrubs associated with the SR 520 right-of-way. Himalayan blackberry is a dominant plant species in this reach. Downstream of the SR 520 right-of-way, the creek flows between commercial buildings before flowing beneath NE 21st Street. Riparian vegetation in this reach is mowed grass. Dominant substrate in the channel consists of a mixture of fine-textured sediment of silt, sand, and small gravels. Large gravels and cobbles are rare. Angular rock is present within the channel. Woody debris is absent within the channel within the project area. Downstream of the project area, the stream flows through an area with forested riparian habitat conditions before flowing into Kelsey Creek.

Valley Creek appears to meet the criteria of a Type F water under the City of Bellevue’s critical areas regulations (100-foot buffer), physically connected to the Mercer Slough (Type S water) via Kelsey Creek by an aboveground channel system, stream, or wetland. Valley Creek is identified on City of Bellevue critical area maps (Bellevue 2013b).

4.3.7 Stream Ratings and Buffers

Appropriate minimum stream buffers were identified according to the current BCC (Bellevue 2013a) and RMC (Redmond 2013a). The BCC and RMC identify minimum protective buffer widths based on the stream rating, as described in Section 4.2. Bellevue and Redmond will determine the final stream ratings and minimum buffers. During the investigation all identified streams were located within the City of Bellevue and none were identified within the City of Redmond. Stream buffer widths based on the local rating are identified in Table 11.

**Table 11
Local Critical Areas Regulations Stream Rating and Buffer Distance**

Stream	Local Stream Rating¹	Buffer Width (feet)
Stream A	Type N	50
Stream B	Type N	50
Wye Creek	Type F	100
Alcove Creek	Type F	100

Stream	Local Stream Rating¹	Buffer Width (feet)
Sturtevant Creek	Type F	502
West Tributary to Kelsey Creek	Type F	100
Stream C	Type O	25
Goff Creek	Type F	50 ²
Unnamed Tributary to Kelsey Creek	Type N	50
Valley Creek	Type F	50 ²

Notes:

- 1 All streams identified during the investigation were located within the City of Bellevue jurisdiction.
- 2 These streams' buffers were applied based on guidance from Bellevue 2013a, Chapter 20.25H.075.C.1.a.

5 JURISDICTIONAL DITCH INVESTIGATION

This section documents the identification of drainage areas that are not wetlands or streams within the project area that meet the Corps' definition of "relatively permanent waters" (RPW) and therefore meet the criteria of jurisdictional features, or "jurisdictional ditches". Eight jurisdictional ditches were identified and delineated within the project area. The jurisdictional ditch regulatory background, delineation methods, and results are described in the following sections.

5.1 Jurisdictional Ditch Regulatory Background

In June 2005, the Corps issued Standard Operating Procedure 2005-01, related to permitting requirements for transportation activities. (The likely impetus for this was uncertainty in the Corps Jurisdiction related to two recent court decisions; the *Headwaters Inc. v. Talent Irrigation District*, 243 F.3d 526 [9th Cir. 2001] and *Solid Waste Agency of Northern Cook County v. United States Army Corps of Engineers* 531 U.S. 159 [Supreme Court 2001]). The Corps document lists, "[F]ill in roadside ditch for slope flattening as required to meet federal and local safety standards for slope grade and shoulder width. This would require the ditch to be replaced with a like system, or adjacent roadside ditch to replace the lost [conveyance and water quality] functions of the filled ditch." Under this guidance, replacement of ditches with similar new ditches can be considered as a self-mitigating action.

The U.S. Supreme Court issued a decision in *Rapanos v. United States*, 547 U.S. 715 (2006), on June 19, 2006. The case was highly influential in defining "waters of the U.S." under the Clean Water Act. The resulting split decision and plural majority resulted in uncertain guidance and key issues being left to the U.S. Environmental Protection Agency and the Corps to clarify. Until the eventual issuance of clarifying guidance in 2007, jurisdiction was extremely difficult to establish.

In June 2007, the Corps issued Regulatory Guidance Letter No. 07-01, on the Practices for Documenting Jurisdiction under Sections 9 & 10 of the Rivers and Harbors Act of 1899 and Section 404 of the Clean Water Act. Under this guidance, the *Rapanos* decision and the procedures for determining if a significant nexus with navigable waters is present are clarified. This significant nexus evaluation is based on the concept that an upstream

waterbody is jurisdiction if it has “more than a speculative or insubstantial” effect on the physical, chemical, and/or biological functions of a downstream waterbody. In the present case, ditches (and other non-navigable waters) with relatively permanent flow (defined as more than 3 months per year) are identified as RPWs, and are normally considered as having a nexus and therefore as jurisdictional. RPWs do not include ephemeral streams that flow only in response to precipitation.

5.2 Jurisdictional Ditch Delineation Methods

Based on the criteria identified by the Corps, jurisdictional ditches in the project area were defined as drainage features that have developed wetland characteristics, but appear to have been intentionally constructed in uplands for stormwater purposes and are not associated with a natural drainage system (they are not classified as wetlands or streams). Jurisdictional ditches in the project area are active stormwater facilities regulated by the Corps. Some of these jurisdictional ditches will be disturbed by proposed East Link Extension Project activities.

Anchor QEA based jurisdictional determinations of whether roadside ditches are considered to be jurisdictional ditches on whether any of the following Corps criteria were present, in association with a “traditional” water of the U.S. (i.e., wetland, stream, Lake Washington, Lake Sammamish, and Mercer Slough):

- A defined bed and bank
- An OHWM or scour mark
- Evidence of flow or, in some cases, standing water (although standing water may indicate infiltration)
- Hydraulic or hydrologic connection to jurisdictional features, such as wetlands or streams

The following features are not considered to be jurisdictional ditches:

- Ditches within streams or wetlands (they are already regulated by the Corps)
- Ditches that appear to infiltrate stormwater (they do not discharge to a wetland, stream, culvert, catch basin, or other stormwater facility)
- Paved ditches

- Areas where water runs on asphalt next to jersey barriers
- Piped or culverted systems
- Shallow depressions, upland swales, tire tracks, and other drainage features without a defined bed and bank

The extent of potential jurisdictional ditches in the field was reviewed and verified to determine where the jurisdictional portion of the ditch ends. This was accomplished by examining all jurisdictional ditches to a point where the jurisdictional features end to establish a “break” between jurisdictional and non-jurisdictional ditch segments. A break is defined as a section of ditch that lacks the defining jurisdictional ditch characteristics listed previously. Absence of these characteristics suggests that water is infiltrating, evaporating, experiencing vegetative uptake, or being dispersed. If all of these features were lacking, then all ditch areas that have the same point of connection to navigable waters of the U.S. were identified as non-jurisdictional. This approach to establish the limits of jurisdiction ensured that all potential jurisdictional ditch sections were identified for the purpose of Section 404 compliance. Pipes or culverts between a ditch and a downstream wetland or stream were not considered to be a break in the jurisdictional status of the ditch, if it otherwise met the criteria for a jurisdictional ditch.

Western Washington receives considerable rain from November to February. The addition of small amounts of shallow groundwater typically results in continuous flow for at least 3 months. On Sound Transit projects, streams are typically defined as areas under the OHWM, with bed and bank that carry natural stream water and originate from a source such as a spring, seep, or seep wetland. The presence of groundwater sources will likely ensure continuous flow for 3 months during the rainy season and will likely meet the definition of RPWs. Sound Transit has identified all streams that are not Traditional Navigable Waters as RPWs, the key being that RPWs have some type of seasonal groundwater source that will result in continuous flow. In addition to naturally occurring streams, natural stream water that flows through a man-made ditch could be classified as a stream, whereas stormwater runoff flowing through a man-made ditch is not considered to be a stream. All of the jurisdictional ditches documented in the project area discharge to culverts or catch basins and flow into streams, wetlands, or other waterbodies outside the project area.

To document jurisdictional ditches within the project area, existing information was reviewed (described in Section 2.1.1), and an aerial photograph analysis was performed, followed by site visits in February, March, April, and May 2013. The jurisdictional ditch delineation was completed by walking the ditches and identifying the ditch boundaries with labeled orange pin-flags demarking each bank individually. Then, flagging was documented on an aerial photograph for survey. Jurisdictional ditch boundaries were either marked with flags in parallel formation on both banks, as in LB-1 (left bank) and RB-1 (right bank), LB-2 and RB-2, etc., or in cases where the stream channel was very narrow, usually less than about 2 feet wide, flagged on the center line of the jurisdictional ditch survey and the average width was recorded. Jurisdictional ditches were described in location from west to east by a numbering sequence from 1 to 8.

5.3 Jurisdictional Ditch Results

There were seven jurisdictional ditches identified within the project area. Based on the above criteria, jurisdictional ditches were identified and photographed within the project area, and information on their characteristics was documented on field data sheets. Information gathered during the February, March, April, and May 2013 site visits included the general location, size, and characteristics of the jurisdictional ditches, and identification of the downstream waterbody into which the jurisdictional ditches eventually flow. The total jurisdictional ditch sizes were calculated by estimating average ditch widths in the field and calculating ditch lengths from survey results. Jurisdictional ditch dimensions are rounded to the thousandth of an acre in the text and the tables of this report due to the relatively small areas. Jurisdictional ditch delineation results are shown on the figures in Appendix D, Frames 10, 12, and 13. Jurisdictional ditch field data forms are included in Appendix E.

Field ecologists did not map or document ditches or other drainage features that did not appear to meet the criteria for jurisdictional status because they appeared to infiltrate and were not connected to any waterbody or stormwater conveyance facility. Table 12 lists the discharge feature (where the jurisdictional ditch drains to), the downstream waterbody that flows from where the jurisdictional ditch enters (outside and within the project area), and jurisdictional characteristics of jurisdictional ditches in the project area (criteria identified in

Section 5.2). Jurisdictional ditch features are not broken out into drainage basins like the wetland stream features are in the previous sections because jurisdictional ditches do not have local regulatory protection as critical areas. The existing dimensions of jurisdictional ditches in the project area are provided on Table 13.

Table 12
Jurisdictional Ditch Summary

Jurisdictional Ditch¹	Discharge Feature	Downstream Waterbody	Jurisdictional Characteristics
JD-1	Culvert	West Tributary to Kelsey Creek via culverts	Bed and bank scour, vegetation absent in scour area, standing and flowing water present, water stains on rock lined ditch
JD-2	Culvert	West Tributary to Kelsey Creek via culverts	Bed and bank scour, flattened vegetation, standing and flowing water present, water stains on rock lined ditch
JD-3	Culvert	West Tributary to Kelsey Creek via culverts	Bed and bank scour, flattened vegetation, standing and flowing water present, water stains on rock lined ditch
JD-4	Culvert	Unnamed Tributary to Kelsey Creek via culverts	Scour signs, flattened vegetation, standing and flowing water present
JD-6	Culvert	Unnamed Tributary to Kelsey Creek via culverts	Bed and bank scour, vegetation absent or flattened in scour area, standing and flowing water present
JD-7	Culvert	Unnamed Tributary to Kelsey Creek via culverts	Bed and bank scour, vegetation absent or flattened in scour area, standing and flowing water present
JD-8	Culvert	Valley Creek via culverts and SR 520 East	Bed and bank scour, vegetation absent in scour area, standing water stains on rock lined ditch

¹ JD-5 was reclassified as part of the Unnamed Trib. to Kelsey Creek.

Table 13
Summary of Jurisdiction Ditch Dimensions

Jurisdictional Ditch²	Length (feet)¹	Width Range (feet)
JD-1	214	2 to 3
JD-2	293	2 to 4
JD-3	56	2 to 3
JD-4	128	3 to 5
JD-6	108	4 to 5
JD-7	40	2 to 3
JD-8	263	4 to 5

Note:

1 Calculations provided by HJH

2 JD-5 was reclassified as part of the Unnamed Trib. to Kelsey Creek.

5.3.1 Jurisdictional Ditch Functions

Jurisdictional ditches provide water quality treatment, sediment removal, and stormwater conveyance. Other functions usually provided by jurisdictional ditches, such as providing habitat for wildlife, are limited within this project area due to their size, lack of vegetation, and location adjacent to existing roads. Jurisdictional ditches in the project area are all active stormwater facilities.

5.3.2 Jurisdictional Ditch Mitigation Approach

The most common effect on jurisdictional ditches will be disturbances and displacement associated with construction near or on existing roads. Project-related mitigation will be provided by replacing the ditches with stormwater collection and treatment facilities for runoff associated with new and existing impervious surfaces. Since the new stormwater collection and treatment facilities will provide the same stormwater conveyance as the jurisdictional ditches, with improved water quality treatment functions, the project is considered to be self-mitigating for jurisdictional ditch functions. In addition, the existing jurisdictional ditches currently collect stormwater runoff from the existing road and stormwater run-on (stormwater from upslope of the road and not associated with road impervious surfaces). Where necessary, new ditches will be constructed to collect and

convey stormwater run-on in the same manner as existing conditions. No additional compensatory mitigation will be proposed for effects to jurisdictional ditches.

6 REFERENCES

- Access Washington, 2009. *Washington State Growth Management Act*. Cited: May 18, 2009. Available from: <http://www.gmhb.wa.gov/gma/index.html>.
- Anchor QEA and H-J-H (Anchor QEA, LLC, and H-J-H Final Design Partners), 2014. *Eastlink Light Rail Extension Critical Areas Report and Mitigation Plan*. Draft Submittal. August 22, 2014.
- Bellevue (City of Bellevue), 2013a. Bellevue Municipal City Code (BCC) Critical Areas Regulations Chapter 20.25H. Bellevue, Washington. Cited: February 1, 2013. Available from: <http://www.codepublishing.com/wa/bellevue/>.
- Bellevue, 2013b. City of Bellevue Drainage Basin Maps. Bellevue, Washington. Cited: February 1, 2013. Available from: <http://www.bellevuewa.gov/drainage-basins.htm>.
- Bellevue, 2013c. Bellevue Land Use Code (LUC). Bellevue, Washington. Cited: May 9, 2014. Available from: <http://www.codepublishing.com/wa/bellevue/LUC/BellevueLUCNT.html>
- Corps (U.S. Army Corps of Engineers), 2010. *Regional Supplement to the Corps of Engineers Wetland Delineation Manual: Western Mountains, Valleys, and Coast Region (Version 2.0)*, eds. J.S. Wakeley, R.W. Lichvar, and C.V. Noble. ERDC/EL TR-10-3. Vicksburg, Mississippi: U.S. Army Engineer Research and Development Center.
- Corps, 2013. *National Wetland Plant List*. U.S. Army Corps of Engineers. Cited: November 1, 2013. Available from: <http://rsgisias.crrel.usace.army.mil/NWPL/#>
- Cowardin, L.M., V. Carter, F.C. Golet, and E.T. LaRoe, 1979. *Classification of Wetlands and Deepwater Habitats of the United States*. U.S. Fish and Wildlife Service, Washington, D.C.
- Ecology (Washington State Department of Ecology), 1997. *Washington State Wetland Identification and Delineation Manual*. Publication #96-94. Olympia, Washington.
- Ecology, 2008. *Washington State Wetland Rating Form – Western Washington, Version 2*. Olympia, Washington.
- Ecology, 2009. *Washington State Shoreline Management Act*. Cited: May 18, 2009. Available from: http://www.ecy.wa.gov/programs/sea/sma/laws_rules/index.html.

- Ecology, 2013. Environmental Information; Watersheds; WRIA 8 Cedar/Sammamish Watershed Basin. Cited: February 1, 2013. Available from: <http://www.ecy.wa.gov/apps/watersheds/wriapages/08.html>.
- Environmental Laboratory, 1987. *U.S. Army Corps of Engineers Wetland Delineation Manual*. Technical Report Y-87-1. U.S. Army Corps of Engineers Waterways Experiment Station, Vicksburg, Mississippi.
- Hruby, T., T. Granger, K. Brunner, S. Cooke, K. Dublanica, R. Gersib, L. Reinelt, K. Richter, D. Sheldon, E. Teachout, A. Wald, and F. Weinmann, 1999. *Methods for Assessing Wetland Functions Volume I: Riverine and Depressional Wetlands in the Lowlands of Western Washington*. WA State Department Ecology Publication #99-115. July.
- Hruby, T., 2004. *Washington State Wetland Rating System for Western Washington: Revised*. Washington State Department of Ecology Publication #04-06-25.
- Louther, Marti, 2013. Sound Transit, Senior Environmental Planner. Personal communication during site visit with Calvin Douglas, Anchor QEA LLC. November 26, 2013.
- Munsell, 1994. *Munsell Soil Color Charts*. Kollmorgen Corporation, Baltimore, Maryland.
- Parametrix, 2012. *Critical Areas Report West Tributary Detention Pond 165 Enhancement Project*. City of Bellevue. December 2012.
- Redmond (City of Redmond), 2013a. Redmond Municipal Code (RMC) Critical Areas Regulations Chapter 20D.140. Redmond, Washington. Cited: February 1, 2013. Available from: <http://www.codepublishing.com/WA/redmond.html>.
- Redmond, 2013b. City of Redmond Maps. Redmond, Washington. Cited: February 1, 2013. Available from: <http://redmond.gov/Government/MapsGISservices/StandardMaps/>.
- Sound Transit (Central Puget Sound Regional Transit Authority), 2011. *East Link Light Rail Project Final Environmental Impact Statement*. July 2011.
- USDA (U.S. Department of Agriculture), 2013a. *Natural Resource Conservation Service (NRCS) Web Soil Survey*. Cited: February 1, 2013. Available from: <http://websoilsurvey.nrcs.usda.gov/app>.

USDA, 2013b. *Hydric Soil List for Washington State*. USDA Soil Conservation Service.
Cited: February 1, 2013. Available from:
http://www.nrcs.usda.gov/Internet/FSE_DOCUMENTS/nrcs143_023872.xls.

USFWS (U.S. Fish and Wildlife Service), 2013. *USFWS Wetlands Mapper for National Wetlands Inventory (NWI) Map Information*. Cited: February 1, 2013. Available from: <http://wetlandsfws.er.usgs.gov>.

WDFW (Washington State Department of Fish and Wildlife), 2013a. WDFW PHS online. Cited: February 1, 2013. Available from: <http://wdfw.wa.gov/mapping/phs/>.

WDFW, 2013b. SalmonScape Interactive mapper – Salmon presence; forage fish spawning habitat. Available from: <http://wdfw.wa.gov/mapping/salmonscape/>. Accessed on: February 2, 2013.

7 LIST OF PREPARERS AND CONTRIBUTORS

This report was prepared for, and under the direction of, H-J-H by Anchor QEA, LLC.

Members of the professional staff are listed below:

Calvin Douglas, Senior Biologist, Anchor QEA, LLC

Joe Pursley, Biologist, Environmental Planner, and Arborist, Anchor QEA, LLC

Ann Costanza, Principal Planner, Anchor QEA, LLC

John Small, Principal Landscape Architect, Anchor QEA, LLC

Lynn Turner, Senior Project Assistant, Anchor QEA, LLC

Chris Broderick, Project Assistant, Anchor QEA, LLC

APPENDIX A
SAMPLE PLOT SUMMARY DATA

Scientific Name	Common Name	Indicator ¹
Trees		
<i>Acer macrophyllum</i>	Big-leaf maple	FACU
<i>Abies grandis</i>	Grand fir	FACU-
<i>Alnus rubra</i>	Red alder	FAC
<i>Arbutus menziesii</i>	Pacific madrona	UPL
<i>Betula papyrifera</i>	Paper birch	FAC
<i>Crataegus douglasii</i>	Black hawthorn	FAC
<i>Cupressocyparis leylandii</i>	Leyland cypress	FACU
<i>Fraxinus latifolia</i>	Oregon ash	FACW
<i>Picea sitchensis</i>	Sitka spruce	FAC
<i>Pinus monticola</i>	Western white pine	FACU
<i>Populus tremuloides</i>	Quaking aspen	FAC+
<i>Populus trichocarpa</i>	Black cottonwood	FAC
<i>Populus balsamifera</i>	Black cottonwood	FAC
<i>Prunus emarginata</i>	Bitter cherry	FACU
<i>Pseudotsuga menziesii</i>	Douglas fir	FACU
<i>Rhamnus purshiana</i>	Cascara	FAC-
<i>Salix hookeriana</i>	Hooker willow	FACW-
<i>Salix lasiandra</i>	Pacific willow	FACW+
<i>Salix scouleriana</i>	Scouler willow	FAC
<i>Thuja plicata</i>	Western red cedar	FAC
<i>Tsuga heterophylla</i>	Western hemlock	FACU-
Shrubs		
<i>Acer circinatum</i>	Vine maple	FAC-
<i>Corylus cornuta</i>	Beaked hazelnut	FACU
<i>Cytisus scoparius</i>	Scot's broom	UPL
<i>Cornus sericea</i>	Red-osier dogwood	FACW
<i>Gaultheria shallon</i>	Salal	FACU
<i>Holodiscus discolor</i>	Oceanspray	UPL
<i>Ilex aquifolium</i>	Holly	FACU
<i>Lonicera involucrata</i>	Twinberry	FAC+
<i>Mahonia aquifolium</i>	Tall Oregon grape	UPL
<i>Oemleria cerasiformis</i>	Indian plum	FACU
<i>Oplopanax horridus</i>	Devil's club	FAC+
<i>Polygonum cuspidatum</i>	Japanese knotweed	FACU
<i>Prunus laurocerasus</i>	Cherry laurel	
<i>Rhododendron macrophyllum</i>	Pacific rhododendron	UPL
<i>Ribes lacustre</i>	Prickly currant	FAC+
<i>Rosa gymnocarpa</i>	Wood rose	FACU
<i>Rosa nutkana</i>	Nootka rose	FAC
<i>Rubus armeniacus</i>	Himalayan blackberry	FACU
<i>Rubus spectabilis</i>	Salmonberry	FAC+
<i>Rubus ursinus</i>	Trailing blackberry	FACU
<i>Sambucus racemosa</i>	Red elderberry	FACU
<i>Spiraea douglasii</i>	Spiraea	FACW
<i>Symphoricarpos albus</i>	Snowberry	FACU
<i>Vaccinium ovatum</i>	Evergreen huckleberry	UPL
Grass, Ferns, & Herbaceous		
<i>Achillea millefolium</i>	Yarrow	FACU
<i>Agrostis capillaris</i>	Colonial bentgrass	FAC
<i>Athyrium filix-femina</i>	Lady fern	FAC+
<i>Brassica campestris</i>	Field mustard	UPL
<i>Brassica sp.</i>	Mustard sp.	NI

Scientific Name	Common Name	Indicator ¹
<i>Callitriche heterophylla</i>	Water-starwort	OBL
<i>Carex deweyana</i>	Dewey sedge	FACU
<i>Carex obnupta</i>	Slough sedge	OBL
<i>Cirsium arvense</i>	Canadian thistle	FACU+
<i>Convolvulus arvensis</i>	Orchard morning glory	UPL
<i>Dipsacus fullonum</i>	Teasal	FAC
<i>Epilobium angustifolium</i>	Fireweed	FACU+
<i>Epilobium watsonii</i>	Watson's willow-herb	FACW-
<i>Equisetum arvense</i>	Field horsetail	FAC
<i>Equisetum telmateia</i>	Giant horsetail	FACW
<i>Festuca rubra</i>	Red fescue	FAC+
<i>Galium trifidum</i>	Small bedstraw	FACW+
<i>Geranium robertianum</i>	Stinky bob	UPL
<i>Hedera hibernica</i>	English ivy	UPL
<i>Hedera helix</i>	English ivy	UPL
<i>Holcus lanatus</i>	Common velvet grass	FAC
<i>Juncus effusus</i>	Soft rush	FACW
<i>Lemna minor</i>	Common duckweed	OBL
<i>Lysichiton americanus</i>	Skunk cabbage	OBL
<i>Myosotis laxa</i>	Forget-me-not	OBL
<i>Oenanthe sarmentosa</i>	Water-parsley	OBL
<i>Phalaris arundinacea</i>	Reed canarygrass	FACW
<i>Plantago lanceolata</i>	English plantain	FAC
<i>Plantago major</i>	Common plantain	FACU+
<i>Poa pratensis</i>	Kentucky bluegrass	FAC
<i>Polystichum munitum</i>	Sword fern	FACU
<i>Pteridium aquilinum</i>	Bracken fern	FACU
<i>Ranunculus repens</i>	Creeping buttercup	FACW
<i>Rumex crispus</i>	Curly dock	FAC+
<i>Sagittaria latifolia</i>	Broadleaf arrowwood	OBL
<i>Salix lucida</i>	Shining willow	FACW
<i>Spiraea douglasii</i>	Hardhack	FACW
<i>Stachys cooleyae</i>	Cooley's hedge-nettle	OBL
<i>Tanacetum vulgare</i>	Common tansy	UPL
<i>Taraxacum officinale</i>	Common dandelion	FACU
<i>Tolmiea menziesii</i>	Piggyback plant	FAC
<i>Trifolium pratense</i>	Red clover	FACU
<i>Trifolium repens</i>	White clover	FAC
<i>Typha latifolia</i>	Cattail	OBL
<i>Urtica dioica</i>	Stinging nettle	FAC+
<i>Verbascum thapsus</i>	Common mullein	UPL
<i>Veronica americana</i>	American speedwell	OBL

Note:

1 These categories, referred to as the "wetland indicator status," (from the wettest to driest habitats) are as follows:

- OBL = obligate wetland plants
- FACW = facultative wetland plants
- FAC = facultative plants
- FACU = facultative upland plants
- NI = Not indicated
- UPL = obligate upland plants.

Wet	SP	Scientific Name	Common Name	Indicator ¹	Cover %
Mercer Slough	1Wet	<i>Athyrium filix-femina</i>	Lady fern	FAC+	20
		<i>Equisetum telmateia</i>	Giant horsetail	FACW	10
		<i>Phalaris arundinacea</i>	Reed canarygrass	FACW	80
		<i>Populus trichocarpa</i>	Black cottonwood	FAC	40
		<i>Rubus armeniacus</i>	Himalayan blackberry	FACU	10
		<i>Thuja plicata</i>	Western red cedar	FAC	40
	2Up	<i>Alnus rubra</i>	Red alder	FAC	20
		<i>Betula papyrifera</i>	Paper birch	FAC	90
		<i>Phalaris arundinacea</i>	Reed canarygrass	FACW	50
		<i>Rubus armeniacus</i>	Himalayan blackberry	FACU	30
		<i>Thuja plicata</i>	Western red cedar	FAC	10
	3Wet	<i>Alnus rubra</i>	Red alder	FAC	70
		<i>Athyrium filix-femina</i>	Lady fern	FAC+	15
		<i>Betula papyrifera</i>	Paper birch	FAC	5
		<i>Carex obnupta</i>	Slough sedge	OBL	20
		<i>Picea sitchensis</i>	Sitka spruce	FAC	30
		<i>Rubus spectabilis</i>	Salmonberry	FAC+	40
		<i>Salix hookeriana</i>	Hooker willow	FACW-	15
	4Up	<i>Alnus rubra</i>	Red alder	FAC	20
		<i>Gaultheria shallon</i>	Salal	FACU	40
		<i>Holodiscus discolor</i>	Oceanspray	UPL	20
		<i>Pseudotsuga menziesii</i>	Douglas fir	FACU	80
		<i>Rosa gymnocarpa</i>	Wood rose	FACU	35
		<i>Rubus spectabilis</i>	Salmonberry	FAC+	30
	5Wet	<i>Rubus spectabilis</i>	Salmonberry	FAC+	80
		<i>Salix lasiandra</i>	Pacific willow	FACW+	30
		<i>Thuja plicata</i>	Western red cedar	FAC	15
	6Up	<i>Acer macrophyllum</i>	Big-leaf maple	FACU	60
		<i>Equisetum telmateia</i>	Giant horsetail	FACW	5
		<i>Ilex aquifolium</i>	Holly	FACU	20
		<i>Oemleria cerasiformis</i>	Indian plum	FACU	10
		<i>Pseudotsuga menziesii</i>	Douglas fir	FACU	20
		<i>Rubus spectabilis</i>	Salmonberry	FAC+	60
		<i>Sambucus racemosa</i>	Red elderberry	FACU	20
		<i>Thuja plicata</i>	Western red cedar	FAC	20
	7Wet	<i>Alnus rubra</i>	Red alder	FAC	70
		<i>Epilobium watsonii</i>	Watson's willow-herb	FACW-	5
		<i>Juncus effusus</i>	Soft rush	FACW	5
		<i>Phalaris arundinacea</i>	Reed canarygrass	FACW	90
		<i>Solanum dulcamara</i>	Bittersweet nightshade	FAC+	5
	8Up	<i>Acer circinatum</i>	Vine maple	FAC-	30
		<i>Alnus rubra</i>	Red alder	FAC	60
	<i>Ilex aquifolium</i>	Holly	FACU	10	
	<i>Phalaris arundinacea</i>	Reed canarygrass	FACW	5	

Wet	SP	Scientific Name	Common Name	Indicator ¹	Cover %
Mercer Slough		<i>Rubus armeniacus</i>	Himalayan blackberry	FACU	30
		<i>Rubus spectabilis</i>	Salmonberry	FAC+	40
	9Wet	<i>Cornus sericea</i>	Red-osier dogwood	FACW	30
		<i>Ranunculus repens</i>	Creeping buttercup	FACW	50
		<i>Rubus armeniacus</i>	Himalayan blackberry	FACU	5
		<i>Salix lasiandra</i>	Pacific willow	FACW+	90
	10Up	<i>Cornus sericea</i>	Red-osier dogwood	FACW	15
		<i>Fraxinus latifolia</i>	Oregon ash	FACW	5
		<i>Lonicera involucrata</i>	Twinberry	FAC+	10
		<i>Polygonum cuspidatum</i>	Japanese knotweed	FACU	10
		<i>Rubus armeniacus</i>	Himalayan blackberry	FACU	25
		<i>Salix lasiandra</i>	Pacific willow	FACW+	30
		<i>Sambucus racemosa</i>	Red elderberry	FACU	15
		<i>Symphoricarpos albus</i>	Snowberry	FACU	50
Alcove Creek	Wet	<i>Alnus rubra</i>	Red alder	FAC	5
		<i>Cornus sericea</i>	Red-osier dogwood	FACW	30
		<i>Fraxinus latifolia</i>	Oregon ash	FACW	5
		<i>Lonicera involucrata</i>	Twinberry	FAC+	5
		<i>Oemleria cerasiformis</i>	Indian plum	FACU	20
		<i>Populus trichocarpa</i>	Black cottonwood	FAC	85
		<i>Rubus armeniacus</i>	Himalayan blackberry	FACU	10
	Up	<i>Abies grandis</i>	Grand fir	FACU-	5
		<i>Fraxinus latifolia</i>	Oregon ash	FACW	75
		<i>Hedera hibernica</i>	English ivy	UPL	10
		<i>Pinus monticola</i>	Western white pine	FACU	5
		<i>Rubus armeniacus</i>	Himalayan blackberry	FACU	40
	<i>Symphoricarpos albus</i>	Snowberry	FACU	45	
Bellefield South	Wet	<i>Alnus rubra</i>	Red alder	FAC	20
		<i>Brassica campestris</i>	Field mustard	UPL	5
		<i>Convolvulus arvensis</i>	Orchard morning glory	UPL	30
		<i>Epilobium watsonii</i>	Watson's willow-herb	FACW-	5
		<i>Fraxinus latifolia</i>	Oregon ash	FACW	75
		<i>Rubus armeniacus</i>	Himalayan blackberry	FACU	10
		<i>Urtica dioica</i>	Stinging nettle	FAC+	70
	Up	<i>Convolvulus arvensis</i>	Orchard morning glory	UPL	40
		<i>Rubus armeniacus</i>	Himalayan blackberry	FACU	10
	<i>Urtica dioica</i>	Stinging nettle	FAC+	70	
Bellefield North	Wet	<i>Cornus sericea</i>	Red-osier dogwood	FACW	40
		<i>Fraxinus latifolia</i>	Oregon ash	FACW	70
		<i>Populus trichocarpa</i>	Black cottonwood	FAC	40
		<i>Rubus armeniacus</i>	Himalayan blackberry	FACU	30
		<i>Urtica dioica</i>	Stinging nettle	FAC+	20
	Up	<i>Populus trichocarpa</i>	Black cottonwood	FAC	5
		<i>Rubus armeniacus</i>	Himalayan blackberry	FACU	80

Wet	SP	Scientific Name	Common Name	Indicator ¹	Cover %	
Bellefield North		<i>Sambucus racemosa</i>	Red elderberry	FACU	20	
		<i>Urtica dioica</i>	Stinging nettle	FAC+	60	
8th Street	Wet	<i>Pseudotsuga menziesii</i>	Douglas fir	FACU	10	
		<i>Rubus armeniacus</i>	Himalayan blackberry	FACU	5	
		<i>Phalaris arundinacea</i>	Reed canarygrass	FACW	30	
		<i>Veronica americana</i>	American speedwell	OBL	30	
		<i>Carex obnupta</i>	Slough sedge	OBL	10	
		<i>Urtica dioica</i>	Stinging nettle	FAC	5	
		<i>Athyrium filix-femina</i>	Lady fern	FAC	10	
	Up	<i>Equisetum arvense</i>	Field horsetail	FAC	10	
		<i>Pseudotsuga menziesii</i>	Douglas fir	FACU	30	
		<i>Cupressocyparis leylandii</i>	Leyland cypress	FACU	10	
		<i>Prunus laurocerasus</i>	Cherry laurel	NI	40	
		<i>Rubus armeniacus</i>	Himalayan blackberry	FACU	5	
		<i>Festuca rubra</i>	Red fescue	FAC	5	
Lake Bellevue	Wet	<i>Salix hookeriana</i>	Hooker willow	FACW	30	
		<i>Populus balsamifera</i>	Black cottonwood	FAC	50	
		<i>Spiraea douglasii</i>	Spirea	FACW	20	
		<i>Phalaris arundinacea</i>	Reed canarygrass	FACW	20	
		<i>Juncus effusus</i>	Soft rush	FACW	5	
		<i>Hedera helix</i>	English ivy	UPL	25	
	Up	<i>Populus trichocarpa</i>	Black cottonwood	FAC	60	
		<i>Alnus rubra</i>	Red alder	FAC	20	
		<i>Ilex aquifolium</i>	Holly	FACU	10	
		<i>Rubus armeniacus</i>	Himalayan blackberry	FACU	30	
		<i>Epilobium watsonii</i>	Watson's willow-herb	FACW	10	
		<i>Equisetum arvense</i>	Field horsetail	FAC	5	
		<i>Hedera helix</i>	English ivy	UPL	100	
		SA SP1-U	<i>Agrostis capillaris</i>	Colonial bentgrass	FAC	5
			<i>Cytisus scoparius</i>	Scot's broom	UPL	10
			<i>Equisetum arvense</i>	Field horsetail	FAC	15
			<i>Juncus effusus</i>	Soft rush	FACW	40
			<i>Phalaris arundinacea</i>	Reed canarygrass	FACW	15
			<i>Rubus armeniacus</i>	Himalayan blackberry	FACU	15
		South Lake	Wet	<i>Equisetum telmateia</i>	Giant horsetail	FACW
<i>Hedera hibernica</i>	English ivy			UPL	10	
<i>Juncus effusus</i>	Soft rush			FACW	1	
<i>Phalaris arundinacea</i>	Reed canarygrass			FACW	90	
<i>Rubus armeniacus</i>	Himalayan blackberry			FACU	20	
<i>Rubus spectabilis</i>	Salmonberry			FAC+	30	
<i>Salix hookeriana</i>	Hooker willow			FACW-	50	
<i>Spiraea douglasii</i>	Spirea			FACW	40	
Up	<i>Epilobium watsonii</i>		Watson's willow-herb	FACW-	15	
	<i>Equisetum arvense</i>		Field horsetail	FAC	15	

Wet	SP	Scientific Name	Common Name	Indicator ¹	Cover %
South Lake		<i>Hedera hibernica</i>	English ivy	UPL	100
		<i>Ilex aquifolium</i>	Holly	FACU	15
		<i>Populus trichocarpa</i>	Black cottonwood	FAC	20
		<i>Rubus armeniacus</i>	Himalayan blackberry	FACU	30
		<i>Salix hookeriana</i>	Hooker willow	FACW-	20
Central Lake	Wet	<i>Alnus rubra</i>	Red alder	FAC	5
		<i>Cornus sericea</i>	Red-osier dogwood	FACW	1
		<i>Epilobium watsonii</i>	Watson's willow-herb	FACW-	20
		<i>Ludwigia palustris</i>	Water purslane	OBL	60
		<i>Phalaris arundinacea</i>	Reed canarygrass	FACW	20
		<i>Rubus armeniacus</i>	Himalayan blackberry	FACU	20
		<i>Spiraea douglasii</i>	Spirea	FACW	50
	Up	<i>Epilobium watsonii</i>	Watson's willow-herb	FACW-	10
		<i>Rubus armeniacus</i>	Himalayan blackberry	FACU	10
		<i>Verbascum thapsus</i>	Common mullein	UPL	1
North Lake	Wet	<i>Alnus rubra</i>	Red alder	FAC	10
		<i>Epilobium watsonii</i>	Watson's willow-herb	FACW-	5
		<i>Juncus effusus</i>	Soft rush	FACW	15
		<i>Phalaris arundinacea</i>	Reed canarygrass	FACW	80
		<i>Rubus armeniacus</i>	Himalayan blackberry	FACU	15
		<i>Salix scouleriana</i>	Scouler willow	FAC	40
		Up	<i>Cirsium arvense</i>	Canadian thistle	FACU+
	<i>Epilobium watsonii</i>		Watson's willow-herb	FACW-	1
	<i>Equisetum arvense</i>		Field horsetail	FAC	1
	<i>Juncus effusus</i>		Soft rush	FACW	20
	<i>Phalaris arundinacea</i>		Reed canarygrass	FACW	80
			<i>Rubus armeniacus</i>	Himalayan blackberry	FACU
BNSF Southwest	Wet	<i>Agrostis capillaris</i>	Colonial bentgrass	FAC	60
		<i>Dipsacus fullonum</i>	Teasal	FAC	1
		<i>Phalaris arundinacea</i>	Reed canarygrass	FACW	20
BNSF Southwest		<i>Poa pratensis</i>	Kentucky bluegrass	FAC	20
		<i>Rumex crispus</i>	Curly dock	FAC+	1
	Up	<i>Agrostis capillaris</i>	Colonial bentgrass	FAC	60
		<i>Cytisus scoparius</i>	Scot's broom	UPL	40
		<i>Phalaris arundinacea</i>	Reed canarygrass	FACW	5
		<i>Rubus armeniacus</i>	Himalayan blackberry	FACU	20
		<i>Tanacetum vulgare</i>	Common tansy	UPL	5
	<i>Trifolium pratense</i>	Red clover	FACU	10	
BNSF East	Wet	<i>Juncus effusus</i>	Soft rush	FACW	15
		<i>Lemna minor</i>	Common duckweed	OBL	30
		<i>Phalaris arundinacea</i>	Reed canarygrass	FACW	50
		<i>Typha latifolia</i>	Cattail	OBL	40
	Up	<i>Agrostis capillaris</i>	Colonial bentgrass	FAC	50

Wet	SP	Scientific Name	Common Name	Indicator ¹	Cover %
BNSF East		<i>Alnus rubra</i>	Red alder	FAC	5
		<i>Festuca rubra</i>	Red fescue	FAC+	15
		<i>Juncus effusus</i>	Soft rush	FACW	10
	SA SP2-U	<i>Agrostis capillaris</i>	Colonial bentgrass	FAC	10
		<i>Alnus rubra</i>	Red alder	FAC	15
		<i>Cytisus scoparius</i>	Scot's broom	UPL	5
		<i>Equisetum arvense</i>	Field horsetail	FAC	10
		<i>Juncus effusus</i>	Soft rush	FACW	35
		<i>Phalaris arundinacea</i>	Reed canarygrass	FACW	15
		<i>Rubus armeniacus</i>	Himalayan blackberry	FACU	20
	<i>Tanacetum vulgare</i>	Common tansy	UPL	1	
BNSF West	1Wet	<i>Agrostis capillaris</i>	Colonial bentgrass	FAC	10
		<i>Athyrium filix-femina</i>	Lady fern	FAC+	15
BNSF West		<i>Phalaris arundinacea</i>	Reed canarygrass	FACW	20
		<i>Salix scouleriana</i>	Scouler willow	FAC	60
		<i>Spiraea douglasii</i>	Spirea	FACW	40
	2Up	<i>Agrostis capillaris</i>	Colonial bentgrass	FAC	60
		<i>Cytisus scoparius</i>	Scot's broom	UPL	40
		<i>Galium trifidum</i>	Small bedstraw	FACW+	1
		<i>Phalaris arundinacea</i>	Reed canarygrass	FACW	10
		<i>Rubus armeniacus</i>	Himalayan blackberry	FACU	30
		<i>Tanacetum vulgare</i>	Common tansy	UPL	5
	3Wet	<i>Equisetum arvense</i>	Field horsetail	FAC	10
		<i>Phalaris arundinacea</i>	Reed canarygrass	FACW	30
		<i>Salix scouleriana</i>	Scouler willow	FAC	95
		<i>Spiraea douglasii</i>	Spirea	FACW	40
		<i>Tolmiea menziesii</i>	Piggyback plant	FAC	10
	4Up	<i>Agrostis capillaris</i>	Colonial bentgrass	FAC	10
		<i>Cirsium arvense</i>	Canadian thistle	FACU+	30
		<i>Equisetum arvense</i>	Field horsetail	FAC	35
		<i>Festuca rubra</i>	Red fescue	FAC+	15
		<i>Ilex aquifolium</i>	Holly	FACU	20
		<i>Oemleria cerasiformis</i>	Indian plum	FACU	15
	<i>Rubus armeniacus</i>	Himalayan blackberry	FACU	10	
BNSF Northeast	Wet	<i>Alnus rubra</i>	Red alder	FAC	60
		<i>Crataegus douglasii</i>	Black hawthorn	FAC	5
		<i>Ludwigia palustris</i>	Water purslane	OBL	20
		<i>Populus trichocarpa</i>	Black cottonwood	FAC	30
		<i>Salix scouleriana</i>	Scouler willow	FAC	10
		<i>Spiraea douglasii</i>	Spirea	FACW	40
	Up	<i>Equisetum arvense</i>	Field horsetail	FAC	1
		<i>Populus trichocarpa</i>	Black cottonwood	FAC	90
	<i>Rubus armeniacus</i>	Himalayan blackberry	FACU	100	

Wet	SP	Scientific Name	Common Name	Indicator ¹	Cover %
BNSF Northwest	Wet	<i>Athyrium filix-femina</i>	Lady fern	FAC+	60
		<i>Epilobium watsonii</i>	Watson's willow-herb	FACW-	5
		<i>Equisetum arvense</i>	Field horsetail	FAC	5
		<i>Hedera hibernica</i>	English ivy	UPL	15
		<i>Juncus effusus</i>	Soft rush	FACW	25
		<i>Lemna minor</i>	Common duckweed	OBL	10
		<i>Ludwigia palustris</i>	Water purslane	OBL	10
		<i>Rubus armeniacus</i>	Himalayan blackberry	FACU	10
		<i>Salix lasiandra</i>	Pacific willow	FACW+	90
	<i>Sambucus racemosa</i>	Red elderberry	FACU	10	
	Up	Bare Ground			100
BNSF North	Wet	<i>Populus trichocarpa</i>	Black cottonwood	FAC	60
		<i>Rubus armeniacus</i>	Himalayan blackberry	FACU	15
		<i>Salix lasiandra</i>	Pacific willow	FACW+	15
BNSF North		<i>Solanum dulcamara</i>	Bittersweet nightshade	FAC+	45
		<i>Spiraea douglasii</i>	Spirea	FACW	10
	Up	<i>Agrostis capillaris</i>	Colonial bentgrass	FAC	10
		<i>Arbutus menziesii</i>	Pacific madrona	UPL	5
		<i>Phalaris arundinacea</i>	Reed canarygrass	FACW	5
		<i>Populus trichocarpa</i>	Black cottonwood	FAC	15
		<i>Rubus armeniacus</i>	Himalayan blackberry	FACU	50
Kelsey West Tributary Pond	W1-SP1	<i>Typha latifolia</i>	Cattail	OBL	90
		<i>Oenanthe sarmentosa</i>	Water-parsley	OBL	20
		<i>Veronica americana</i>	American speedwell	OBL	10
		<i>Myosotis laxa</i>	Forget-me not	OBL	2
		<i>Gallium trifidum</i>	Small bedstraw	FACW	2
		<i>Callitriche heterophylla</i>	Water-starwort	OBL	15
		<i>Brassica sp.</i>	Mustard sp.	NI	5
		<i>Sagittaria latifolia</i>	Broadleaf arrowwood	OBL	2
	W1-SP2	<i>Alnus rubra</i>	Red alder	FAC	60
		<i>Populus balsamifera</i>	Black cottonwood	FAC	40
		<i>Cornus sericea</i>	Red-osier dogwood	FACW	7
		<i>Oemleria cerasiformis</i>	Indian plum	FACU	2
		<i>Rubus armeniacus</i>	Himalayan blackberry	FACU	90
	W1-SP3	<i>Salix lucida</i>	Shining willow	FACW	75
		<i>Spiraea douglasii</i>	Hardhack	FACW	5
		<i>Cornus sericea</i>	Red-osier dogwood	FACW	2
		<i>Phalaris arundinacea</i>	Reed canarygrass	FACW	40
Kelsey West Tributary Stream	1RWet	<i>Cornus sericea</i>	Red-osier dogwood	FACW	25
		<i>Epilobium angustifolium</i>	Fireweed	FACU+	10
		<i>Juncus effusus</i>	Soft rush	FACW	15
		<i>Phalaris arundinacea</i>	Reed canarygrass	FACW	90
		<i>Rubus armeniacus</i>	Himalayan blackberry	FACU	10
		<i>Salix lasiandra</i>	Pacific willow	FACW+	20

Wet	SP	Scientific Name	Common Name	Indicator ¹	Cover %
Kelsey West Tributary Stream		<i>Solanum dulcamara</i>	Bittersweet nightshade	FAC+	30
	2RUp	<i>Agrostis capillaris</i>	Colonial bentgrass	FAC	30
		<i>Polygonum cuspidatum</i>	Japanese knotweed	FACU	20
		<i>Rubus armeniacus</i>	Himalayan blackberry	FACU	90
		<i>Solanum dulcamara</i>	Bittersweet nightshade	FAC+	30
	3LWet	<i>Oemleria cerasiformis</i>	Indian plum	FACU	15
		<i>Phalaris arundinacea</i>	Reed canarygrass	FACW	90
		<i>Salix lasiandra</i>	Pacific willow	FACW+	30
		<i>Solanum dulcamara</i>	Bittersweet nightshade	FAC+	20
		<i>Stachys cooleyae</i>	Cooley's hedge-nettle	OBL	5
	4LUp	<i>Populus trichocarpa</i>	Black cottonwood	FAC	40
		<i>Rubus armeniacus</i>	Himalayan blackberry	FACU	80
	SA SP3-U	<i>Agrostis capillaris</i>	Colonial bentgrass	FAC	5
		<i>Equisetum arvense</i>	Field horsetail	FAC	15
		<i>Juncus effusus</i>	Soft rush	FACW	50
	SA SP4-U	<i>Agrostis capillaris</i>	Colonial bentgrass	FAC	1
		<i>Equisetum arvense</i>	Field horsetail	FAC	20
	<i>Juncus effusus</i>	Soft rush	FACW	60	
136th Place	Wet	<i>Alnus rubra</i>	Red alder	FAC	50
		<i>Equisetum arvense</i>	Field horsetail	FAC	1
136th Place		<i>Lonicera involucrata</i>	Twinberry	FAC+	25
		<i>Phalaris arundinacea</i>	Reed canarygrass	FACW	20
		<i>Salix lasiandra</i>	Pacific willow	FACW+	30
		<i>Solanum dulcamara</i>	Bittersweet nightshade	FAC+	15
	Up	<i>Alnus rubra</i>	Red alder	FAC	50
		<i>Equisetum arvense</i>	Field horsetail	FAC	10
		<i>Hedera hibernica</i>	English ivy	UPL	60
		<i>Ilex aquifolium</i>	Holly	FACU	10
SR 520 West	1Wet	<i>Epilobium watsonii</i>	Watson's willow-herb	FACW-	5
		<i>Oenanthe sarmentosa</i>	Water-parsley	OBL	90
		<i>Salix lasiandra</i>	Pacific willow	FACW+	40
		<i>Spiraea douglasii</i>	Spirea	FACW	20
	2Up	<i>Equisetum arvense</i>	Field horsetail	FAC	60
		<i>Pseudotsuga menziesii</i>	Douglas fir	FACU	95
		<i>Rubus armeniacus</i>	Himalayan blackberry	FACU	10
	3Wet	<i>Alnus rubra</i>	Red alder	FAC	90
		<i>Cornus sericea</i>	Red-osier dogwood	FACW	40
		<i>Equisetum arvense</i>	Field horsetail	FAC	5
		<i>Lysichiton americanus</i>	Skunk cabbage	OBL	20
		<i>Oenanthe sarmentosa</i>	Water-parsley	OBL	5
		<i>Rubus armeniacus</i>	Himalayan blackberry	FACU	10
	4Up	<i>Salix lasiandra</i>	Pacific willow	FACW+	15
		<i>Alnus rubra</i>	Red alder	FAC	25
		<i>Cytisus scoparius</i>	Scot's broom	UPL	10

Wet	SP	Scientific Name	Common Name	Indicator ¹	Cover %	
SR 520 West		<i>Hedera hibernica</i>	English ivy	UPL	25	
		<i>Ilex aquifolium</i>	Holly	FACU	15	
		<i>Polystichum munitum</i>	Sword fern	FACU	10	
		<i>Populus trichocarpa</i>	Black cottonwood	FAC	70	
		<i>Rubus armeniacus</i>	Himalayan blackberry	FACU	50	
		<i>Symphoricarpos albus</i>	Snowberry	FACU	5	
Valley Creek	1Wet	<i>Alnus rubra</i>	Red alder	FAC	40	
		<i>Epilobium watsonii</i>	Watson's willow-herb	FACW-	5	
		<i>Equisetum arvense</i>	Field horsetail	FAC	20	
		<i>Phalaris arundinacea</i>	Reed canarygrass	FACW	40	
		<i>Populus trichocarpa</i>	Black cottonwood	FAC	5	
		<i>Rubus armeniacus</i>	Himalayan blackberry	FACU	60	
		<i>Salix lasiandra</i>	Pacific willow	FACW+	5	
		<i>Solanum dulcamara</i>	Bittersweet nightshade	FAC+	5	
		<i>Spiraea douglasii</i>	Spirea	FACW	20	
		<i>Typha latifolia</i>	Cattail	OBL	20	
	2Up	<i>Alnus rubra</i>	Red alder	FAC	60	
		<i>Cornus sericea</i>	Red-osier dogwood	FACW	10	
		<i>Equisetum arvense</i>	Field horsetail	FAC	30	
		<i>Oemleria cerasiformis</i>	Indian plum	FACU	25	
Valley Creek		<i>Phalaris arundinacea</i>	Reed canarygrass	FACW	10	
		<i>Populus trichocarpa</i>	Black cottonwood	FAC	40	
		<i>Pseudotsuga menziesii</i>	Douglas fir	FACU	10	
		<i>Rubus armeniacus</i>	Himalayan blackberry	FACU	40	
		<i>Spiraea douglasii</i>	Spirea	FACW	30	
	3Wet	<i>Alnus rubra</i>	Red alder	FAC	30	
		<i>Epilobium watsonii</i>	Watson's willow-herb	FACW-	5	
		<i>Equisetum arvense</i>	Field horsetail	FAC	20	
		<i>Phalaris arundinacea</i>	Reed canarygrass	FACW	100	
		<i>Rubus armeniacus</i>	Himalayan blackberry	FACU	20	
		<i>Salix lasiandra</i>	Pacific willow	FACW+	50	
		<i>Solanum dulcamara</i>	Bittersweet nightshade	FAC+	5	
		<i>Spiraea douglasii</i>	Spirea	FACW	20	
		4Up	<i>Alnus rubra</i>	Red alder	FAC	20
			<i>Geranium robertianum</i>	Stinky bob	UPL	1
	<i>Ranunculus repens</i>		Creeping buttercup	FACW	5	
			<i>Rubus armeniacus</i>	Himalayan blackberry	FACU	100
SR 520 East	Wet	<i>Alnus rubra</i>	Red alder	FAC	40	
		<i>Athyrium filix-femina</i>	Lady fern	FAC+	40	
		<i>Equisetum arvense</i>	Field horsetail	FAC	15	
		<i>Lysichiton americanus</i>	Skunk cabbage	OBL	10	
		<i>Populus trichocarpa</i>	Black cottonwood	FAC	50	
		<i>Prunus emarginata</i>	Bitter cherry	FACU	25	

Wet	SP	Scientific Name	Common Name	Indicator ¹	Cover %
SR 520 East		<i>Rubus armeniacus</i>	Himalayan blackberry	FACU	40
		<i>Salix scouleriana</i>	Scouler willow	FAC	10
	Up	<i>Geranium robertianum</i>	Stinky bob	UPL	5
		<i>Hedera hibernica</i>	English ivy	UPL	15
		<i>Oemleria cerasiformis</i>	Indian plum	FACU	10
		<i>Pseudotsuga menziesii</i>	Douglas fir	FACU	20
		<i>Rubus armeniacus</i>	Himalayan blackberry	FACU	35
		<i>Thuja plicata</i>	Western red cedar	FAC	55

Note:

1 These categories, referred to as the “wetland indicator status,” (from the wettest to driest habitats) are as follows:

OBL = obligate wetland plants

FACW = facultative wetland plants

FAC = facultative plants

FACU = facultative upland plants

NI = not indicated

UPL = obligate upland plants.

Wet	SP	Soil Horizon (in)	Matrix Color	Redox Color	Redox Abundance (%)	Texture
Mercer Slough	1Wet	0 to 7	10YR 2/1	None	None	Silt loam w/roots
		7 to 10	10YR 2/1	None	None	Silt
		10 to 18+	10YR 2/1	None	None	Silt w/organic material
	2Up	0 to 4	10YR 3/2	None	None	Loam
		4 to 18+	10YR 3/4	None	None	Sandy loam
	3Wet	0 to 6	10YR 2/1	None	None	Loam
		6 to 9	10YR 2/1	None	None	Silt loam
		9 to 12	10YR 2/2	None	None	Silt w/organic material
		12 to 18+	10YR 3/1	None	None	Sandy silt
	4Up	0 to 4	10YR 2/2	None	None	Sandy loam
		4 to 18+	10YR 3/6	None	None	Sandy loam
	5Wet	0 to 7	10YR 2/1	None	None	Silt loam
		7 to 10	10YR 2/1	None	None	Silt w/organic material
		10 to 18+	10YR 2/1	None	None	Silt w/organic material
	6Up	0 to 10	10YR 2/2	None	None	Sandy loam
		10 to 18+	10YR 3/3	None	None	Sandy loam w/roots
	7Wet	0 to 10	10YR 4/1	None	None	Sandy loam w/cobble & coarse wood layers
		10 to 18+	10YR 5/1	None	None	Sandy loam w/ coarse wood layers
	8Up	0 to 18+	10YR 3/3	None	None	Sand w/gravel & cobble
	9Wet	0 to 6	10YR 3/1	None	None	Loam w/gravel
	6 to 18+	10YR 4/1	10YR 6/2	5	Clay loam w/cobble & gravel	
10Up	0 to 10	10YR 3/2	None	None	Loam	
	10 to 18+	10YR 4/2	None	None	Loam w/cobble	
Bellefield South	Wet	0 to 14	10YR 2/1	None	None	Loam w/organic material & pieces of brick & charcoal
		14 to 18+	10YR 3/3	None	None	Loam w/coarse organic material not decomposed
	Up	0 to 15	10YR 2/2	None	None	Loam
		15 to 18+	10YR 2/2	None	None	Loam w/coarse organic material
Bellefield North	Wet	0 to 18+	10YR 2/1	None	None	Loam
	Up	0 to 12	10YR 3/4	None	None	Loam w/pieces of brick & charcoal
		0 to 12	10YR 5/4	None	None	Loam w/pieces of brick & charcoal
		12 to 18+	10YR 2/2	None	None	Loam
Alcove Creek	Wet	0 to 1	Duff/leaf litter	None	None	Duff/leaf litter
		1 to 18+	10YR 3/1	None	None	Silt loam w/organic material
	Up	0 to 18+	10YR 2/2	None	None	Sandy loam w/gravel & cobble
8th Street	Wet	0 to 1	10YR 2/1	None	None	Silt w/ fine to coarse root material
		1 to 18+	10YR 2/1	None	None	Some sand and fine gravel and rock

Wet	SP	Soil Horizon (in)	Matrix Color	Redox Color	Redox Abundance (%)	Texture
8th Street	Up	0 to 18+	10YR 3/2	None	None	Loam with rounded gravel and rock
Lake Bellevue	Wet	0 to 2	10YR 2/1	None	None	Loam w/ roots throughout
		2 to 18+	10YR 2/1	None	None	Sandy loam w/ rocks and sand
	Up	0 to 3	10YR 3/3	None	None	Sandy loam w/ gravel and coarse root material
		3 to 18+	10YR 3/3	None	None	Sandy loam w/ gravel, cobble, and angular rock
	SA SP1-U	0 to 7	10YR 3/3	10YR 4/2	2	Sandy loam w/gravel, cobble, and angular rock
	7 to 18+	None	None	None	Compact fill w/cobble & gravel	
South Lake	Wet	0 to 3	10YR 3/2	None	None	Silt w/roots
		3 to 18+	10YR 2/1	None	None	Loam w/roots
	Up	0 to 4	10YR 3/3	None	None	Sandy loam w/gravel
		4 to 18+	10YR 3/3	None	None	Sandy loam w/gravel, cobble, and angular rock
Central Lake	Wet	0 to 3	10YR 3/1	None	None	Silt loam w/high organic content
		3 to 8	10YR 5/2	10YR 5/6	40	Sandy loam w/gravel
		8 to 18+	Gley 1 5/5G	None	None	Sandy clay w/gravel & angular rock
	Up	0 to 18+	None	None	None	Fill prism w/gravel & angular rock
North Lake	Wet	0 to 5	10YR 2/1	None	None	Loam w/rounded & angular rock
		5 to 8	10YR 3/1	None	None	Loam w/angular rock
		8 to 18+	10YR 5/1	10YR 5/6	40	Sandy clay w/angular rock
	Up	0 to 18+	10YR 3/3	None	None	Sandy loam w/cobble
BNSF Southwest	Wet	0 to 2	10YR 4/2	None	None	Sandy silt w/gravel
		2 to 6	10YR 4/2	10YR 5/1	30	Sandy silt w/gravel & cobble
		6 to 18+	10YR 4/2	10YR 5/1	40	Sandy silt w/gravel
	Up	0 to 18+	10YR 5/3	10YR 4/6	15	Sandy clay w/gravel
BNSF East	Wet	0 to 1	Duff/leaf litter	None	None	Duff/leaf litter
		1 to 18+	10YR 5/1	None	None	Silt loam
	Up	0 to 4	10YR 5/4	None	None	Clay loam
		4 to 18+	10YR 5/4	None	None	Clay loam w/cobble & gravel
	SA SP2-U	0 to 10	10YR 3/4	None	None	Sandy loam w/cobble & gravel
	10 to 18+	None	None	None	Compact fill w/cobble & gravel	
BNSF West	1Wet	0 to 3	10YR 4/1	None	None	Silt loam
		3 to 4	10YR 4/1	None	None	Silt loam w/cobble & gravel
		4 to 18+	10YR 4/1	10YR 5/6	40	Silt loam w/gravel
	2Up	0 to 4	10YR 5/4	10YR 4/2	30	Sandy loam w/gravel
		4 to 10	10YR 4/3	10YR 4/2	25	Sandy loam w/gravel
		10 to 18+	10YR 4/3	10YR 4/2	25	Sandy loam w/gravel & cobble
	3Wet	0 to 3	10YR 4/1	None	None	Silt loam

Wet	SP	Soil Horizon (in)	Matrix Color	Redox Color	Redox Abundance (%)	Texture
BNSF West		3 to 6	10YR 4/1	None	None	Silt loam w/gravel
		6 to 18+	10YR 4/1	None	None	Silt loam w/gravel & cobble
	4Up	0 to 18+	10YR 4/2	None	None	Sandy loam w/gravel & angular rock
BNSF Northeast	Wet	0 to 7	10YR 4/1	None	None	Silt loam w/dense root layer
		7 to 10	10YR 4/1	None	None	Silt loam
		10 to 18+	10YR 4/1	None	None	Loam w/gravel
BNSF Northwest	Up	0 to 18+	10YR 3/3	10YR 5/3	2	Clay loam w/gravel
	Wet	0 to 3	10YR 3/2	10YR 5/1	20	Silt loam
		3 to 18+	10YR 4/1	10YR 4/4	10	Sandy loam w/gravel & cobble
BNSF North	Up	0 to 18+	Angular rock fill prism			
	Wet	0 to 2	10YR 3/1	None	None	Silt loam w/roots
		2 to 6	10YR 3/1	None	None	Silt loam
		6 to 18+	10YR 5/1	10YR 5/4	10	Silt loam w/gravel
	Up	0 to 4	Fill	None	None	Gravel angular rock/railroad prism
Kelsey West Tributary Pond		4 to 18+	10YR 3/4	None	None	Silt w/gravel fill dominant
	W1-SP1	0 to 12	10YR 2/1	None	None	Silty muck
		12 to 19	2.5Y 4/1	None	None	Silt loam, soil is historically disturbed (carbon)
	W1-SP2	0 to 18	2.5Y 3/2	None	None	Silt loam
	W1-SP3	0 to 5	10YR 3/1	None	None	Loam, many roots in layer
		5 to 9	2.5Y 4/1	None	None	Sandy loam
Kelsey West Tributary Stream		9 to 18	5Y 5/1	7.5YR 3/4	10	Gravel, sandy loam, cobbles and carbon in layer
	1RWet	0 to 18+	10YR 3/1	None	None	Silt loam
	2RUUp	0 to 18+	10YR 2/2	None	None	Sandy loam w/cobble, gravel, & angular rock
	3LWet	0 to 18+	10YR 3/1	None	None	Silt loam
	4LUUp	0 to 18+	10YR 2/2	None	None	Sandy loam w/cobble, gravel, & angular rock
	SA SP3-U	0 to 5	10YR 4/3	None	None	Sandy loam w/cobble & gravel
		5 to 18+	None	None	None	Compact fill w/cobble & gravel
	SA SP4-U	0 to 7	10YR 4/3	None	None	Sandy loam w/cobble & gravel
136th Place		7 to 18+	None	None	None	Compact fill w/cobble & gravel
	Wet	0 to 18+	10YR 2/1	None	None	Silt w/organic material
	Up	0 to 10	10YR 2/2	None	None	Loam w/dense roots
	10 to 18+	10YR 3/2	None	None	Loam	

Wet	SP	Soil Horizon (in)	Matrix Color	Redox Color	Redox Abundance (%)	Texture
SR 520 West	1Wet	0 to 2	Duff/leaf litter	None	None	Duff/leaf litter
		2 to 18+	10YR 3/1	None	None	Silt loam
	2Up	0 to 8	10YR 3/3	None	None	Sandy loam w/gravel
		8 to 18+	10YR 4/3	None	None	Loamy sand w/angular rock
	3Wet	0 to 18+	10YR 3/1	None	None	Sandy loam w/gravel
	4Up	0 to 7	10YR 3/3	None	None	Sandy loam w/gravel
		7 to 18+	10YR 4/3	None	None	Sandy loam w/cobble
Valley Creek	1Wet	0 to 1	Duff/leaf litter	None	None	Duff/leaf litter
		1 to 7	10YR 3/1	None	None	Sandy loam
		7 to 18+	10YR 3/1	10YR 5/3	5	Sand
	2Up	0 to 4	10YR 4/4	None	None	Loam
		4 to 18+	Fill	None	None	Fill
	3Wet	0 to 7	10YR 3/1	None	None	Loam
		7 to 18+	2.5Y 6/1	2.5Y 6/6	5	Sandy loam
4Up	0 to 18+	10YR 3/4	None	None	Sandy loam	
SR 520 East	Wet	0 to 7	10YR 3/1	None	None	Loam
		7 to 18+	10YR 4/1	None	None	Sandy loam
	Up	0 to 6	10YR 4/4	None	None	Sandy loam
		6 to 18+	10YR 4/4	None	None	Sandy loam w/gravel

Wet	SP	Hydrology
Mercer Slough	1Wet	Saturation at surface, water table observed at 6 inches from surface
	2Up	No saturation or water table observed within sample plot
	3Wet	Saturation at surface, water table observed at 11 inches from surface
	4Up	No saturation or water table observed within sample plot
	5Wet	Saturation at surface, no water table observed at 18 inches from surface
	6Up	No saturation or water table observed within sample plot
	7Wet	Saturation at surface, water table observed at 7 inches from surface
	8Up	No saturation or water table observed within sample plot
	9Wet	Saturation at surface, no water table observed within sample plot
	10Up	No saturation or water table observed within sample plot
Alcove Creek	Wet	Saturation at surface, water table observed at 5 inches from surface
	Up	No saturation or water table observed within sample plot
Bellefield South	Wet	Saturation at surface, no water table observed within sample plot
	Up	No saturation or water table observed within sample plot
Bellefield North	Wet	Saturation at 6 inches, no water table observed within sample plot
	Up	No saturation or water table observed within sample plot
8th Street	Wet	Saturation at surface, water table observed at 15 inches from surface
	Up	No saturation or water table observed within sample plot
Lake Bellevue	Wet	Saturation at surface, water table observed at 2 inches from surface
	Up	No saturation or water table observed within sample plot
	SA SP1-U	No saturation or water table observed within sample plot
South Lake	Wet	Saturation at surface, water table observed at 1 inch from surface
	Up	No saturation or water table observed within sample plot
Central Lake	Wet	Saturation at surface, water table observed at 5 inches from surface
	Up	No saturation or water table observed within sample plot
North Lake	Wet	Saturation at surface, water table observed at 3 inches from surface
	Up	No saturation or water table observed within sample plot
BNSF Southwest	Wet	Saturation at surface, water table observed at 6 inches from surface
	Up	No saturation or water table observed within sample plot
BNSF East	Wet	Standing water 5 inches deep
	Up	No saturation or water table observed within sample plot
	SA SP2-U	No saturation or water table observed within sample plot
BNSF West	1Wet	Saturation at surface, water table observed at 2 inches from surface
	2Up	No saturation or water table observed within sample plot
	3Wet	Saturation at surface, water table observed at 2 inches from surface
	4Up	No saturation or water table observed within sample plot
BNSF Northeast	Wet	Saturation at surface, water table observed at 1 inch from surface
	Up	No saturation or water table observed within sample plot
BNSF Northwest	Wet	Saturation at surface, water table observed at 8 inches from surface
	Up	No saturation or water table observed within sample plot
BNSF North	Wet	Standing water 1 inch deep
	Up	No saturation or water table observed within sample plot

Wet	SP	Hydrology
Kelsey West Tributary Pond	W1-SP1	Saturation at surface, water table observed at 3 inches from surface
	W1-SP2	No saturation or water table observed within sample plot
	W1-SP3	Saturation at surface, water table observed at 15 inches from surface
Kelsey West Tributary Stream	1RWet	Saturation at surface, water table observed at 5 inches from surface
	2RUp	No saturation or water table observed within sample plot
	3LWet	Saturation at surface, water table observed at 5 inches from surface
	4LUp	No saturation or water table observed within sample plot
	SA SP3-U	No saturation or water table observed within sample plot
	SA SP4-U	No saturation or water table observed within sample plot
136th Place	Wet	Standing water at surface
	Up	No saturation or water table observed within sample plot
SR 520 West	1Wet	Standing water 4 inches deep
	2Up	No saturation or water table observed within sample plot
	3Wet	Standing water 2 inches deep
	4Up	No saturation or water table observed within sample plot
Valley Creek	1Wet	Saturation at surface, water table observed at 8 inches from surface
	2Up	No saturation or water table observed within sample plot
	3Wet	Saturation at surface, no water table observed within sample plot
	4Up	No saturation or water table observed within sample plot
SR 520 East	Wet	Saturation at surface, water table observed at 4 inches from surface
	Up	No saturation or water table observed within sample plot

Wet	SP	Vegetation	Soils	Hydrology	Determination
Mercer Slough	1Wet	Hydrophytic	Hydric	Positive	Wetland
	2Up	Hydrophytic	Non-hydric	Negative	Upland
	3Wet	Hydrophytic	Hydric	Positive	Wetland
	4Up	Non-hydrophytic	Non-hydric	Negative	Upland
	5Wet	Hydrophytic	Hydric	Positive	Wetland
	6Up	Hydrophytic	Non-hydric	Negative	Upland
	7Wet	Hydrophytic	Hydric	Positive	Wetland
	8Up	Hydrophytic	Non-hydric	Negative	Upland
	9Wet	Hydrophytic	Hydric	Positive	Wetland
	10Up	Non-hydrophytic	Non-hydric	Negative	Upland
Alcove Creek	Wet	Hydrophytic	Hydric	Positive	Wetland
	Up	Non-hydrophytic	Non-hydric	Negative	Upland
Bellefield South	Wet	Hydrophytic	Hydric	Positive	Wetland
	Up	Non-hydrophytic	Non-hydric	Negative	Upland
Bellefield North	Wet	Hydrophytic	Hydric	Positive	Wetland
	Up	Hydrophytic	Non-hydric	Negative	Upland
8th Street	Wet	Hydrophytic	Hydric	Positive	Wetland
	Up	Non-hydrophytic	Non-hydric	Negative	Upland
Lake Bellevue	Wet	Hydrophytic	Hydric	Positive	Wetland
	Up	Hydrophytic	Non-hydric	Negative	Upland
	SA SP1-U	Hydrophytic	Non-hydric	Negative	Upland
South Lake	Wet	Hydrophytic	Hydric	Positive	Wetland
	Up	Hydrophytic	Non-hydric	Negative	Upland
Central Lake	Wet	Hydrophytic	Hydric	Positive	Wetland
	Up	Hydrophytic	Non-hydric	Negative	Upland
North Lake	Wet	Hydrophytic	Hydric	Positive	Wetland
	Up	Hydrophytic	Non-hydric	Negative	Upland
BNSF Southwest	Wet	Hydrophytic	Hydric	Positive	Wetland
	Up	Non-hydrophytic	Non-hydric	Negative	Upland
BNSF East	Wet	Hydrophytic	Hydric	Positive	Wetland
	Up	Hydrophytic	Non-hydric	Negative	Upland
	SA SP2-U	Hydrophytic	Non-hydric	Negative	Upland
BNSF West	1Wet	Hydrophytic	Hydric	Positive	Wetland
	2Up	Non-hydrophytic	Non-hydric	Negative	Upland
	3Wet	Hydrophytic	Hydric	Positive	Wetland
	4Up	Non-hydrophytic	Non-hydric	Negative	Upland
BNSF Northeast	Wet	Hydrophytic	Hydric	Positive	Wetland
	Up	Hydrophytic	Non-hydric	Negative	Upland
BNSF Northwest	Wet	Hydrophytic	Hydric	Positive	Wetland
	Up	Non-hydrophytic	Non-hydric	Negative	Upland
BNSF North	Wet	Hydrophytic	Hydric	Positive	Wetland
	Up	Hydrophytic	Non-hydric	Negative	Upland

Wet	SP	Vegetation	Soils	Hydrology	Determination
Kelsey West Tributary Pond	W1-SP1	Hydrophytic	Hydric	Positive	Wetland
	W1-SP2	Hydrophytic	Non-hydric	Negative	Upland
	W1-SP3	Hydrophytic	Hydric	Positive	Wetland
Kelsey West Tributary Stream	1RWet	Hydrophytic	Hydric	Positive	Wetland
	2RUp	Hydrophytic	Non-hydric	Negative	Upland
	3LWet	Hydrophytic	Hydric	Positive	Wetland
	4LUp	Hydrophytic	Non-hydric	Negative	Upland
	SA SP3-U	Hydrophytic	Non-hydric	Negative	Upland
	SA SP4-U	Hydrophytic	Non-hydric	Negative	Upland
136th Place	Wet	Hydrophytic	Hydric	Positive	Wetland
	Up	Hydrophytic	Non-hydric	Negative	Upland
SR 520 West	1Wet	Hydrophytic	Hydric	Positive	Wetland
	2Up	Non-hydrophytic	Non-hydric	Negative	Upland
	3Wet	Hydrophytic	Hydric	Positive	Wetland
	4Up	Non-hydrophytic	Non-hydric	Negative	Upland
Valley Creek	1Wet	Hydrophytic	Hydric	Positive	Wetland
	2Up	Hydrophytic	Non-hydric	Negative	Upland
	3Wet	Hydrophytic	Hydric	Positive	Wetland
	4Up	Hydrophytic	Non-hydric	Negative	Upland
SR 520 East	Wet	Hydrophytic	Hydric	Positive	Wetland
	Up	Non-hydrophytic	Non-hydric	Negative	Upland

APPENDIX B
WETLAND DELINEATION FIELD DATA
FORMS

WETLAND DETERMINATION DATA FORM – Western Mountains, Valleys, and Coast Region

Project Site: Sound Transit East Link Extension Project City/County: Bellevue/King Sampling Date: April 9, 2013
 Applicant/Owner: Sound Transit State: WA Sampling Point: 136th Place SPU
 Investigator(s): C Douglas & J. Pursley Section, Township, Range: S28, T24N, R5E
 Landform (hillslope, terrace, etc.): Narrow area between development Local relief (concave, convex, none): concave Slope (%): 0% to 4%
 Subregion (LRR): A Lat: 47.62N Long: 122.15W Datum: _____
 Soil Map Unit Name: Bellingham silt loam NWI classification: None Mapped
 Are climatic / hydrologic conditions on the site typical for this time of year? Yes No (If no, explain in Remarks.)
 Are Vegetation , Soil , or Hydrology , significantly disturbed? Are "Normal Circumstances" present? Yes No
 Are Vegetation , Soil , or Hydrology , naturally problematic? (If needed, explain any answers in Remarks.)

SUMMARY OF FINDINGS – Attach site map showing sampling point locations, transects, important features, etc.

Hydrophytic Vegetation Present?	Yes <input checked="" type="checkbox"/>	No <input type="checkbox"/>	Is the Sampled Area within a Wetland?	Yes <input type="checkbox"/>	No <input checked="" type="checkbox"/>
Hydric Soil Present?	Yes <input type="checkbox"/>	No <input checked="" type="checkbox"/>		Yes <input type="checkbox"/>	No <input checked="" type="checkbox"/>
Wetland Hydrology Present?	Yes <input type="checkbox"/>	No <input checked="" type="checkbox"/>		Yes <input type="checkbox"/>	No <input checked="" type="checkbox"/>
Remarks: Wetland is located in narrow area between commercial development. Wetland appears to be part of a relic stream channel with culverts at the north and south ends of the wetland. No flow was present at the time of the investigation and recent evidence of flow was lacking. Wetland includes depressionnal HGM class.					

VEGETATION – Use scientific names of plants

Tree Stratum (Plot size: 30 foot radius)	Absolute % Cover	Dominant Species?	Indicator Status	Dominance Test Worksheet:																
1. <u><i>Alnus rubra</i></u>	50	yes	FAC	Number of Dominant Species That Are OBL, FACW, or FAC: <u>3</u> (A) Total Number of Dominant Species Across All Strata: <u>4</u> (B) Percent of Dominant Species That Are OBL, FACW, or FAC: <u>50</u> (A/B)																
2. _____	_____	_____	_____																	
3. _____	_____	_____	_____																	
4. _____	_____	_____	_____																	
50% = <u>1</u> , 20% = <u>0</u>	50	= Total Cover																		
<u>Sapling/Shrub Stratum (Plot size: 15 foot radius)</u>				Prevalence Index worksheet: <table style="width: 100%; border: none;"> <tr> <td style="text-align: right;">Total % Cover of:</td> <td style="text-align: right;">Multiply by:</td> </tr> <tr> <td>OBL species _____</td> <td>x1 = _____</td> </tr> <tr> <td>FACW species _____</td> <td>x2 = _____</td> </tr> <tr> <td>FAC species _____</td> <td>x3 = _____</td> </tr> <tr> <td>FACU species _____</td> <td>x4 = _____</td> </tr> <tr> <td>UPL species _____</td> <td>x5 = _____</td> </tr> <tr> <td>Column Totals: _____ (A)</td> <td>_____ (B)</td> </tr> <tr> <td colspan="2" style="text-align: center;">Prevalence Index = B/A = _____</td> </tr> </table>	Total % Cover of:	Multiply by:	OBL species _____	x1 = _____	FACW species _____	x2 = _____	FAC species _____	x3 = _____	FACU species _____	x4 = _____	UPL species _____	x5 = _____	Column Totals: _____ (A)	_____ (B)	Prevalence Index = B/A = _____	
Total % Cover of:	Multiply by:																			
OBL species _____	x1 = _____																			
FACW species _____	x2 = _____																			
FAC species _____	x3 = _____																			
FACU species _____	x4 = _____																			
UPL species _____	x5 = _____																			
Column Totals: _____ (A)	_____ (B)																			
Prevalence Index = B/A = _____																				
1. <u><i>Ilex aquifolium</i></u>	10	yes	FACU																	
2. _____	_____	_____	_____																	
3. _____	_____	_____	_____																	
4. _____	_____	_____	_____																	
5. _____	_____	_____	_____																	
50% = <u>1</u> , 20% = <u>0</u>	10	= Total Cover																		
<u>Herb Stratum (Plot size: 3 foot radius)</u>				Hydrophytic Vegetation Indicators: <input type="checkbox"/> 1 – Rapid Test for Hydrophytic Vegetation <input checked="" type="checkbox"/> 2 - Dominance Test is >50% <input type="checkbox"/> 3 - Prevalence Index is $\leq 3.0^1$ <input type="checkbox"/> 4 - Morphological Adaptations ¹ (Provide supporting data in Remarks or on a separate sheet) <input type="checkbox"/> 5 - Wetland Non-Vascular Plants ¹ <input type="checkbox"/> Problematic Hydrophytic Vegetation ¹ (Explain) ¹ Indicators of hydric soil and wetland hydrology must be present, unless disturbed or problematic.																
1. <u><i>Equisetum arvense</i></u>	10	yes	FAC																	
2. _____	_____	_____	_____																	
3. _____	_____	_____	_____																	
4. _____	_____	_____	_____																	
5. _____	_____	_____	_____																	
6. _____	_____	_____	_____																	
7. _____	_____	_____	_____																	
8. _____	_____	_____	_____																	
9. _____	_____	_____	_____																	
10. _____	_____	_____	_____																	
11. _____	_____	_____	_____																	
50% = <u>1</u> , 20% = <u>0</u>	10	= Total Cover																		
<u>Woody Vine Stratum (Plot size: 3 foot radius)</u>				Hydrophytic Vegetation Present? <table style="width: 100%; border: none;"> <tr> <td style="text-align: right;">Yes</td> <td style="text-align: center;"><input checked="" type="checkbox"/></td> <td style="text-align: right;">No</td> <td style="text-align: center;"><input type="checkbox"/></td> </tr> </table>	Yes	<input checked="" type="checkbox"/>	No	<input type="checkbox"/>												
Yes	<input checked="" type="checkbox"/>	No	<input type="checkbox"/>																	
1. <u><i>Hedera hibernica</i></u>	60	yes	UPL																	
2. _____	_____	_____	_____																	
50% = _____, 20% = _____	60	= Total Cover																		
% Bare Ground in Herb Stratum <u>30</u>																				

Remarks: 50% dominant wetland vegetation per the Dominance Test, only 2 dominant species.

SOIL

Profile Description: (Describe to the depth needed to document the indicator or confirm the absence of indicators.)

Depth (inches)	Matrix		Redox Features				Texture	Remarks
	Color (moist)	%	Color (moist)	%	Type ¹	Loc ²		
0 to 0	10YR 2/2	100	None	None	None	None	Loam	w/dense roots
10 to 18+	10YR 3/2	100	None	None	None	None	Loam	
_____	_____	_____	_____	_____	_____	_____	_____	_____
_____	_____	_____	_____	_____	_____	_____	_____	_____
_____	_____	_____	_____	_____	_____	_____	_____	_____
_____	_____	_____	_____	_____	_____	_____	_____	_____

¹Type: C= Concentration, D=Depletion, RM=Reduced Matrix, CS=Covered or Coated Sand Grains. ²Location: PL=Pore Lining, M=Matrix

Hydric Soil Indicators: (Applicable to all LRRs, unless otherwise noted.)			Indicators for Problematic Hydric Soils ³ :		
<input type="checkbox"/>	Histosol (A1)	<input type="checkbox"/>	Sandy Redox (S5)	<input type="checkbox"/>	2 cm Muck (A10)
<input type="checkbox"/>	Histic Epipedon (A2)	<input type="checkbox"/>	Stripped Matrix (S6)	<input type="checkbox"/>	Red Parent Material (TF2)
<input type="checkbox"/>	Black Histic (A3)	<input type="checkbox"/>	Loamy Mucky Mineral (F1) (except MLRA 1)	<input type="checkbox"/>	Very Shallow Dark Surface (TF12)
<input type="checkbox"/>	Hydrogen Sulfide (A4)	<input type="checkbox"/>	Loamy Gleyed Matrix (F2)	<input type="checkbox"/>	Other (Explain in Remarks)
<input type="checkbox"/>	Depleted Below Dark Surface (A11)	<input type="checkbox"/>	Depleted Matrix (F3)		
<input type="checkbox"/>	Thick Dark Surface (A12)	<input type="checkbox"/>	Redox Dark Surface (F6)		
<input type="checkbox"/>	Sandy Mucky Mineral (S1)	<input type="checkbox"/>	Depleted Dark Surface (F7)		
<input type="checkbox"/>	Sandy Gleyed Matrix (S4)	<input type="checkbox"/>	Redox Depressions (F8)		

³Indicators of hydrophytic vegetation and wetland hydrology must be present, unless disturbed or problematic.

Restrictive Layer (if present): Type: _____ Depth (inches): _____	Hydric Soils Present? Yes <input type="checkbox"/> No <input checked="" type="checkbox"/>
--	--

Remarks: 2 chroma

HYDROLOGY

Wetland Hydrology Indicators:			
Primary Indicators (minimum of one required; check all that apply)		Secondary Indicators (2 or more required)	
<input type="checkbox"/>	Surface Water (A1)	<input type="checkbox"/>	Water-Stained Leaves (B9)
<input type="checkbox"/>	High Water Table (A2)	<input type="checkbox"/>	(except MLRA 1, 2, 4A, and 4B)
<input type="checkbox"/>	Saturation (A3)	<input type="checkbox"/>	Salt Crust (B11)
<input type="checkbox"/>	Water Marks (B1)	<input type="checkbox"/>	Aquatic Invertebrates (B13)
<input type="checkbox"/>	Sediment Deposits (B2)	<input type="checkbox"/>	Hydrogen Sulfide Odor (C1)
<input type="checkbox"/>	Drift Deposits (B3)	<input type="checkbox"/>	Oxidized Rhizospheres along Living Roots (C3)
<input type="checkbox"/>	Algal Mat or Crust (B4)	<input type="checkbox"/>	Presence of Reduced Iron (C4)
<input type="checkbox"/>	Iron Deposits (B5)	<input type="checkbox"/>	Recent Iron Reduction in Tilled Soils (C6)
<input type="checkbox"/>	Surface Soil Cracks (B6)	<input type="checkbox"/>	Stunted or Stresses Plants (D1) (LRR A)
<input type="checkbox"/>	Inundation Visible on Aerial Imagery (B7)	<input type="checkbox"/>	Other (Explain in Remarks)
<input type="checkbox"/>	Sparsely Vegetated Concave Surface (B8)	<input type="checkbox"/>	Frost-Heave Hummocks (D7)

Field Observations: Surface Water Present? Yes <input type="checkbox"/> No <input checked="" type="checkbox"/> Depth (inches): _____ Water Table Present? Yes <input type="checkbox"/> No <input checked="" type="checkbox"/> Depth (inches): _____ Saturation Present? (includes capillary fringe) Yes <input type="checkbox"/> No <input checked="" type="checkbox"/> Depth (inches): _____	Wetland Hydrology Present? Yes <input type="checkbox"/> No <input checked="" type="checkbox"/>
---	---

Describe Recorded Data (stream gauge, monitoring well, aerial photos, previous inspections), if available:

Remarks: No saturation or water table observed in sample plot

WETLAND DETERMINATION DATA FORM – Western Mountains, Valleys, and Coast Region

Project Site: Sound Transit East Link Extension Project City/County: Bellevue/King Sampling Date: April 9, 2013
 Applicant/Owner: Sound Transit State: WA Sampling Point: 136th Place SPW
 Investigator(s): C Douglas & J. Pursley Section, Township, Range: S28, T24N, R5E
 Landform (hillslope, terrace, etc.): Narrow area between development Local relief (concave, convex, none): concave Slope (%): 0% to 4%
 Subregion (LRR): A Lat: 47.62N Long: 122.15W Datum: _____
 Soil Map Unit Name: Bellingham silt loam NWI classification: None Mapped
 Are climatic / hydrologic conditions on the site typical for this time of year? Yes No (If no, explain in Remarks.)
 Are Vegetation , Soil , or Hydrology , significantly disturbed? Are "Normal Circumstances" present? Yes No
 Are Vegetation , Soil , or Hydrology , naturally problematic? (If needed, explain any answers in Remarks.)

SUMMARY OF FINDINGS – Attach site map showing sampling point locations, transects, important features, etc.

Hydrophytic Vegetation Present?	Yes <input checked="" type="checkbox"/>	No <input type="checkbox"/>	Is the Sampled Area within a Wetland?	Yes <input checked="" type="checkbox"/>	No <input type="checkbox"/>
Hydric Soil Present?	Yes <input checked="" type="checkbox"/>	No <input type="checkbox"/>		Yes <input checked="" type="checkbox"/>	No <input type="checkbox"/>
Wetland Hydrology Present?	Yes <input checked="" type="checkbox"/>	No <input type="checkbox"/>			
Remarks: Wetland is located in narrow area between commercial development. Wetland appears to be part of a relic stream channel with culverts at the north and south ends of the wetland. No flow was present at the time of the investigation and recent evidence of flow was lacking. Wetland includes depressionnal HGM class.					

VEGETATION – Use scientific names of plants

Tree Stratum (Plot size: 30 foot radius)	Absolute % Cover	Dominant Species?	Indicator Status	Dominance Test Worksheet:																
1. <u><i>Alnus rubra</i></u>	<u>50</u>	<u>yes</u>	<u>FAC</u>	Number of Dominant Species That Are OBL, FACW, or FAC: <u>5</u> (A) Total Number of Dominant Species Across All Strata: <u>5</u> (B) Percent of Dominant Species That Are OBL, FACW, or FAC: <u>100</u> (A/B)																
2. <u><i>Salix lasiandra</i></u>	<u>30</u>	<u>yes</u>	<u>FACW</u>																	
3. _____	_____	_____	_____																	
4. _____	_____	_____	_____																	
50% = <u>1</u> , 20% = <u>1</u>	<u>80</u>	= Total Cover		Prevalence Index worksheet: <table style="width: 100%; border: none;"> <tr> <td style="text-align: right;">Total % Cover of:</td> <td style="text-align: left;">Multiply by:</td> </tr> <tr> <td>OBL species _____</td> <td>x1 = _____</td> </tr> <tr> <td>FACW species _____</td> <td>x2 = _____</td> </tr> <tr> <td>FAC species _____</td> <td>x3 = _____</td> </tr> <tr> <td>FACU species _____</td> <td>x4 = _____</td> </tr> <tr> <td>UPL species _____</td> <td>x5 = _____</td> </tr> <tr> <td>Column Totals: _____ (A)</td> <td>_____ (B)</td> </tr> <tr> <td colspan="2" style="text-align: center;">Prevalence Index = B/A = _____</td> </tr> </table>	Total % Cover of:	Multiply by:	OBL species _____	x1 = _____	FACW species _____	x2 = _____	FAC species _____	x3 = _____	FACU species _____	x4 = _____	UPL species _____	x5 = _____	Column Totals: _____ (A)	_____ (B)	Prevalence Index = B/A = _____	
Total % Cover of:	Multiply by:																			
OBL species _____	x1 = _____																			
FACW species _____	x2 = _____																			
FAC species _____	x3 = _____																			
FACU species _____	x4 = _____																			
UPL species _____	x5 = _____																			
Column Totals: _____ (A)	_____ (B)																			
Prevalence Index = B/A = _____																				
<u>Sapling/Shrub Stratum (Plot size: 15 foot radius)</u>																				
1. <u><i>Lonicera involucrata</i></u>	<u>25</u>	<u>yes</u>	<u>FAC</u>																	
2. <u><i>Solanum dulcamara</i></u>	<u>15</u>	<u>yes</u>	<u>FAC</u>																	
3. _____	_____	_____	_____																	
4. _____	_____	_____	_____																	
5. _____	_____	_____	_____																	
50% = <u>1</u> , 20% = <u>1</u>	<u>40</u>	= Total Cover																		
<u>Herb Stratum (Plot size: 3 foot radius)</u>																				
1. <u><i>Equisetum arvense</i></u>	<u>1</u>	<u>no</u>	<u>FAC</u>	Hydrophytic Vegetation Indicators: <input type="checkbox"/> 1 – Rapid Test for Hydrophytic Vegetation <input checked="" type="checkbox"/> 2 - Dominance Test is >50% <input type="checkbox"/> 3 - Prevalence Index is $\leq 3.0^1$ <input type="checkbox"/> 4 - Morphological Adaptations ¹ (Provide supporting data in Remarks or on a separate sheet) <input type="checkbox"/> 5 - Wetland Non-Vascular Plants ¹ <input type="checkbox"/> Problematic Hydrophytic Vegetation ¹ (Explain) ¹ Indicators of hydric soil and wetland hydrology must be present, unless disturbed or problematic.																
2. <u><i>Phalaris arundinacea</i></u>	<u>20</u>	<u>yes</u>	<u>FACW</u>																	
3. _____	_____	_____	_____																	
4. _____	_____	_____	_____																	
5. _____	_____	_____	_____																	
6. _____	_____	_____	_____																	
7. _____	_____	_____	_____																	
8. _____	_____	_____	_____																	
9. _____	_____	_____	_____																	
10. _____	_____	_____	_____																	
11. _____	_____	_____	_____																	
50% = <u>1</u> , 20% = <u>0</u>	<u>21</u>	= Total Cover																		
<u>Woody Vine Stratum (Plot size: 3 foot radius)</u>																				
1. _____	_____	_____	_____																	
2. _____	_____	_____	_____																	
50% = _____, 20% = _____	<u>0</u>	= Total Cover																		
% Bare Ground in Herb Stratum <u>79</u>																				

Remarks: 100% dominant wetland vegetation per the Dominance Test

SOIL

Profile Description: (Describe to the depth needed to document the indicator or confirm the absence of indicators.)

Depth (inches)	Matrix		Redox Features				Texture	Remarks
	Color (moist)	%	Color (moist)	%	Type ¹	Loc ²		
<u>0 to 18+</u>	<u>10YR 2/1</u>	<u>100</u>	<u>None</u>	<u>None</u>	<u>None</u>	<u>None</u>	<u>Silt</u>	<u>w/dense organic material</u>
_____	_____	_____	_____	_____	_____	_____	_____	_____
_____	_____	_____	_____	_____	_____	_____	_____	_____
_____	_____	_____	_____	_____	_____	_____	_____	_____
_____	_____	_____	_____	_____	_____	_____	_____	_____
_____	_____	_____	_____	_____	_____	_____	_____	_____

¹Type: C= Concentration, D=Depletion, RM=Reduced Matrix, CS=Covered or Coated Sand Grains. ²Location: PL=Pore Lining, M=Matrix

Hydric Soil Indicators: (Applicable to all LRRs, unless otherwise noted.)		Indicators for Problematic Hydric Soils³:	
<input type="checkbox"/> Histosol (A1)	<input type="checkbox"/> Sandy Redox (S5)	<input type="checkbox"/> 2 cm Muck (A10)	
<input type="checkbox"/> Histic Epipedon (A2)	<input type="checkbox"/> Stripped Matrix (S6)	<input type="checkbox"/> Red Parent Material (TF2)	
<input type="checkbox"/> Black Histic (A3)	<input type="checkbox"/> Loamy Mucky Mineral (F1) (except MLRA 1)	<input type="checkbox"/> Very Shallow Dark Surface (TF12)	
<input type="checkbox"/> Hydrogen Sulfide (A4)	<input type="checkbox"/> Loamy Gleyed Matrix (F2)	<input type="checkbox"/> Other (Explain in Remarks)	
<input type="checkbox"/> Depleted Below Dark Surface (A11)	<input type="checkbox"/> Depleted Matrix (F3)		
<input checked="" type="checkbox"/> Thick Dark Surface (A12)	<input type="checkbox"/> Redox Dark Surface (F6)		
<input type="checkbox"/> Sandy Mucky Mineral (S1)	<input type="checkbox"/> Depleted Dark Surface (F7)		
<input type="checkbox"/> Sandy Gleyed Matrix (S4)	<input type="checkbox"/> Redox Depressions (F8)		

³Indicators of hydrophytic vegetation and wetland hydrology must be present, unless disturbed or problematic.

Restrictive Layer (if present):	Hydric Soils Present? Yes <input checked="" type="checkbox"/> No <input type="checkbox"/>
Type: _____ Depth (inches): _____	

Remarks: 1 chroma

HYDROLOGY

Wetland Hydrology Indicators:
 Primary Indicators (minimum of one required; check all that apply) Secondary Indicators (2 or more required)

<input checked="" type="checkbox"/> Surface Water (A1)	<input checked="" type="checkbox"/> Water-Stained Leaves (B9)	<input type="checkbox"/> Water-Stained Leaves (B9)
<input checked="" type="checkbox"/> High Water Table (A2)	(except MLRA 1, 2, 4A, and 4B)	(MLRA 1, 2, 4A, and 4B)
<input checked="" type="checkbox"/> Saturation (A3)	<input type="checkbox"/> Salt Crust (B11)	<input type="checkbox"/> Drainage Patterns (B10)
<input type="checkbox"/> Water Marks (B1)	<input type="checkbox"/> Aquatic Invertebrates (B13)	<input type="checkbox"/> Dry-Season Water Table (C2)
<input type="checkbox"/> Sediment Deposits (B2)	<input type="checkbox"/> Hydrogen Sulfide Odor (C1)	<input type="checkbox"/> Saturation Visible on Aerial Imagery (C9)
<input type="checkbox"/> Drift Deposits (B3)	<input type="checkbox"/> Oxidized Rhizospheres along Living Roots (C3)	<input type="checkbox"/> Geomorphic Position (D2)
<input type="checkbox"/> Algal Mat or Crust (B4)	<input type="checkbox"/> Presence of Reduced Iron (C4)	<input type="checkbox"/> Shallow Aquitard (D3)
<input type="checkbox"/> Iron Deposits (B5)	<input type="checkbox"/> Recent Iron Reduction in Tilled Soils (C6)	<input type="checkbox"/> FAC-Neutral Test (D5)
<input type="checkbox"/> Surface Soil Cracks (B6)	<input type="checkbox"/> Stunted or Stresses Plants (D1) (LRR A)	<input type="checkbox"/> Raised Ant Mounds (D6) (LRR A)
<input type="checkbox"/> Inundation Visible on Aerial Imagery (B7)	<input type="checkbox"/> Other (Explain in Remarks)	<input type="checkbox"/> Frost-Heave Hummocks (D7)
<input type="checkbox"/> Sparsely Vegetated Concave Surface (B8)		

Field Observations:	Wetland Hydrology Present? Yes <input checked="" type="checkbox"/> No <input type="checkbox"/>
Surface Water Present? Yes <input checked="" type="checkbox"/> No <input type="checkbox"/> Depth (inches): <u>Surface</u>	
Water Table Present? Yes <input checked="" type="checkbox"/> No <input type="checkbox"/> Depth (inches): <u>Surface</u>	
Saturation Present? (includes capillary fringe) Yes <input checked="" type="checkbox"/> No <input type="checkbox"/> Depth (inches): <u>Surface</u>	

Describe Recorded Data (stream gauge, monitoring well, aerial photos, previous inspections), if available:

Remarks: Saturation, water table, & surface water observed in sample plot

WETLAND DETERMINATION DATA FORM – Western Mountains, Valleys, and Coast Region

Project Site: Sound Transit East Link Extension Project City/County: Bellevue/King Sampling Date: May 30, 2013
 Applicant/Owner: Sound Transit State: WA Sampling Point: 8th Street SPU
 Investigator(s): E. Pizzichemi & J. Pursley Section, Township, Range: S5, T24N, R5E
 Landform (hillslope, terrace, etc.): Slope Local relief (concave, convex, none): concave Slope (%): 0% to 4%
 Subregion (LRR): A Lat: 47.60N Long: 122.19W Datum: _____
 Soil Map Unit Name: AqC & Sk NWI classification: None mapped
 Are climatic / hydrologic conditions on the site typical for this time of year? Yes No (If no, explain in Remarks.)
 Are Vegetation , Soil , or Hydrology , significantly disturbed? Are "Normal Circumstances" present? Yes No
 Are Vegetation , Soil , or Hydrology , naturally problematic? (If needed, explain any answers in Remarks.)

SUMMARY OF FINDINGS – Attach site map showing sampling point locations, transects, important features, etc.

Hydrophytic Vegetation Present?	Yes <input type="checkbox"/>	No <input checked="" type="checkbox"/>	Is the Sampled Area within a Wetland?	Yes <input type="checkbox"/>	No <input checked="" type="checkbox"/>
Hydric Soil Present?	Yes <input type="checkbox"/>	No <input checked="" type="checkbox"/>		Yes <input type="checkbox"/>	No <input checked="" type="checkbox"/>
Wetland Hydrology Present?	Yes <input type="checkbox"/>	No <input checked="" type="checkbox"/>		Yes <input type="checkbox"/>	No <input checked="" type="checkbox"/>
Remarks: Wetland is located between a city street and a residential development. The wetland includes depressional and slope HGM classes. The depressional area is adjacent to the city street fill pipism fed by the residential home slope areas. The upland soil plot was located west of the wetland toward the residential development.					

VEGETATION – Use scientific names of plants

Tree Stratum (Plot size: 30 foot radius)	Absolute % Cover	Dominant Species?	Indicator Status	Dominance Test Worksheet:																
1. <i>Pseudotsuga menziesii</i>	30	yes	FACU	Number of Dominant Species That Are OBL, FACW, or FAC: <u>0</u> (A) Total Number of Dominant Species Across All Strata: <u>2</u> (B) Percent of Dominant Species That Are OBL, FACW, or FAC: <u>0</u> (A/B)																
2. <i>Cupressocyparis leylandii</i>	10	no	FACU																	
3. <i>Prunus laurocerasus</i>	40	yes	_____																	
4. _____	_____	_____	_____																	
50% = <u>1</u> , 20% = <u>1</u>	<u>85</u>	= Total Cover		Prevalence Index worksheet: <table style="width: 100%; border: none;"> <tr> <td style="text-align: center;"><u>Total % Cover of:</u></td> <td style="text-align: center;"><u>Multiply by:</u></td> </tr> <tr> <td>OBL species _____</td> <td>x1 = _____</td> </tr> <tr> <td>FACW species _____</td> <td>x2 = _____</td> </tr> <tr> <td>FAC species _____</td> <td>x3 = _____</td> </tr> <tr> <td>FACU species _____</td> <td>x4 = _____</td> </tr> <tr> <td>UPL species _____</td> <td>x5 = _____</td> </tr> <tr> <td>Column Totals: _____ (A)</td> <td>_____ (B)</td> </tr> <tr> <td colspan="2" style="text-align: center;">Prevalence Index = B/A = _____</td> </tr> </table>	<u>Total % Cover of:</u>	<u>Multiply by:</u>	OBL species _____	x1 = _____	FACW species _____	x2 = _____	FAC species _____	x3 = _____	FACU species _____	x4 = _____	UPL species _____	x5 = _____	Column Totals: _____ (A)	_____ (B)	Prevalence Index = B/A = _____	
<u>Total % Cover of:</u>	<u>Multiply by:</u>																			
OBL species _____	x1 = _____																			
FACW species _____	x2 = _____																			
FAC species _____	x3 = _____																			
FACU species _____	x4 = _____																			
UPL species _____	x5 = _____																			
Column Totals: _____ (A)	_____ (B)																			
Prevalence Index = B/A = _____																				
Sapling/Shrub Stratum (Plot size: 15 foot radius)																				
1. <i>Rubus armeniacus</i>	5	no	FACU																	
2. _____	_____	_____	_____																	
3. _____	_____	_____	_____																	
4. _____	_____	_____	_____																	
5. _____	_____	_____	_____																	
50% = <u>0</u> , 20% = <u>0</u>	<u>5</u>	= Total Cover																		
Herb Stratum (Plot size: 3 foot radius)																				
1. <i>Festuca rubra</i>	5	no	FAC	Hydrophytic Vegetation Indicators: <input type="checkbox"/> 1 – Rapid Test for Hydrophytic Vegetation <input type="checkbox"/> 2 - Dominance Test is >50% <input type="checkbox"/> 3 - Prevalence Index is $\leq 3.0^1$ <input type="checkbox"/> 4 - Morphological Adaptations ¹ (Provide supporting data in Remarks or on a separate sheet) <input type="checkbox"/> 5 - Wetland Non-Vascular Plants ¹ <input type="checkbox"/> Problematic Hydrophytic Vegetation ¹ (Explain) ¹ Indicators of hydric soil and wetland hydrology must be present, unless disturbed or problematic.																
2. _____	_____	_____	_____																	
3. _____	_____	_____	_____																	
4. _____	_____	_____	_____																	
5. _____	_____	_____	_____																	
6. _____	_____	_____	_____																	
7. _____	_____	_____	_____																	
8. _____	_____	_____	_____																	
9. _____	_____	_____	_____																	
10. _____	_____	_____	_____																	
11. _____	_____	_____	_____																	
50% = <u>0</u> , 20% = <u>0</u>	<u>5</u>	= Total Cover																		
Woody Vine Stratum (Plot size: 3 foot radius)																				
1. _____	_____	_____	_____																	
2. _____	_____	_____	_____																	
50% = _____, 20% = _____	<u>0</u>	= Total Cover																		
% Bare Ground in Herb Stratum <u>0</u>																				
Hydrophytic Vegetation Present? Yes <input type="checkbox"/> No <input checked="" type="checkbox"/>																				

Remarks: The area is dominated by a thick English laurel hedge which borders the residential development property line.

SOIL

Profile Description: (Describe to the depth needed to document the indicator or confirm the absence of indicators.)								
Depth (inches)	Matrix		Redox Features				Texture	Remarks
	Color (moist)	%	Color (moist)	%	Type ¹	Loc ²		
0 to 18+	10YR 3/2	100	None	None	None	None	Loam	with rounded gravel & rock
_____	_____	_____	_____	_____	_____	_____	_____	_____
_____	_____	_____	_____	_____	_____	_____	_____	_____
_____	_____	_____	_____	_____	_____	_____	_____	_____
_____	_____	_____	_____	_____	_____	_____	_____	_____
_____	_____	_____	_____	_____	_____	_____	_____	_____
_____	_____	_____	_____	_____	_____	_____	_____	_____

¹Type: C= Concentration, D=Depletion, RM=Reduced Matrix, CS=Covered or Coated Sand Grains. ²Location: PL=Pore Lining, M=Matrix

Hydric Soil Indicators: (Applicable to all LRRs, unless otherwise noted.)				Indicators for Problematic Hydric Soils ³ :	
<input type="checkbox"/>	Histosol (A1)	<input type="checkbox"/>	Sandy Redox (S5)	<input type="checkbox"/>	2 cm Muck (A10)
<input type="checkbox"/>	Histic Epipedon (A2)	<input type="checkbox"/>	Stripped Matrix (S6)	<input type="checkbox"/>	Red Parent Material (TF2)
<input type="checkbox"/>	Black Histic (A3)	<input type="checkbox"/>	Loamy Mucky Mineral (F1) (except MLRA 1)	<input type="checkbox"/>	Very Shallow Dark Surface (TF12)
<input type="checkbox"/>	Hydrogen Sulfide (A4)	<input type="checkbox"/>	Loamy Gleyed Matrix (F2)	<input type="checkbox"/>	Other (Explain in Remarks)
<input type="checkbox"/>	Depleted Below Dark Surface (A11)	<input type="checkbox"/>	Depleted Matrix (F3)		
<input type="checkbox"/>	Thick Dark Surface (A12)	<input type="checkbox"/>	Redox Dark Surface (F6)		
<input type="checkbox"/>	Sandy Mucky Mineral (S1)	<input type="checkbox"/>	Depleted Dark Surface (F7)		
<input type="checkbox"/>	Sandy Gleyed Matrix (S4)	<input type="checkbox"/>	Redox Depressions (F8)		

³Indicators of hydrophytic vegetation and wetland hydrology must be present, unless disturbed or problematic.

Restrictive Layer (if present):	Hydric Soils Present?	Yes	No
Type: _____		<input type="checkbox"/>	<input checked="" type="checkbox"/>
Depth (inches): _____		<input type="checkbox"/>	<input checked="" type="checkbox"/>

Remarks: 2 chroma with no redox features

HYDROLOGY

Wetland Hydrology Indicators:			
Primary Indicators (minimum of one required; check all that apply)		Secondary Indicators (2 or more required)	
<input type="checkbox"/>	Surface Water (A1)	<input type="checkbox"/>	Water-Stained Leaves (B9)
<input type="checkbox"/>	High Water Table (A2)	<input type="checkbox"/>	(except MLRA 1, 2, 4A, and 4B)
<input type="checkbox"/>	Saturation (A3)	<input type="checkbox"/>	Salt Crust (B11)
<input type="checkbox"/>	Water Marks (B1)	<input type="checkbox"/>	Aquatic Invertebrates (B13)
<input type="checkbox"/>	Sediment Deposits (B2)	<input type="checkbox"/>	Hydrogen Sulfide Odor (C1)
<input type="checkbox"/>	Drift Deposits (B3)	<input type="checkbox"/>	Oxidized Rhizospheres along Living Roots (C3)
<input type="checkbox"/>	Algal Mat or Crust (B4)	<input type="checkbox"/>	Presence of Reduced Iron (C4)
<input type="checkbox"/>	Iron Deposits (B5)	<input type="checkbox"/>	Recent Iron Reduction in Tilled Soils (C6)
<input type="checkbox"/>	Surface Soil Cracks (B6)	<input type="checkbox"/>	Stunted or Stresses Plants (D1) (LRR A)
<input type="checkbox"/>	Inundation Visible on Aerial Imagery (B7)	<input type="checkbox"/>	Other (Explain in Remarks)
<input type="checkbox"/>	Sparsely Vegetated Concave Surface (B8)		

Field Observations:		Wetland Hydrology Present?	
Surface Water Present?	Yes <input type="checkbox"/> No <input checked="" type="checkbox"/>	Yes	<input checked="" type="checkbox"/>
Water Table Present?	Yes <input type="checkbox"/> No <input checked="" type="checkbox"/>	No	<input type="checkbox"/>
Saturation Present? (includes capillary fringe)	Yes <input type="checkbox"/> No <input checked="" type="checkbox"/>		

Describe Recorded Data (stream gauge, monitoring well, aerial photos, previous inspections), if available:

Remarks: No saturation or water table observed in sample plot. Soil mplot is located in a steep slope adjacent to a residential property line dominated by ornamental and non-native plant species.

WETLAND DETERMINATION DATA FORM – Western Mountains, Valleys, and Coast Region

Project Site: Sound Transit East Link Extension Project City/County: Bellevue/King Sampling Date: May 30, 2013
 Applicant/Owner: Sound Transit State: WA Sampling Point: 8th Street SPW
 Investigator(s): E. Pizzichemi & J. Pursley Section, Township, Range: S5, T24N, R5E
 Landform (hillslope, terrace, etc.): Slope, Depression Local relief (concave, convex, none): concave Slope (%): 0% to 4%
 Subregion (LRR): A Lat: 47.60N Long: 122.19W Datum: _____
 Soil Map Unit Name: AqC & Sk NWI classification: None mapped
 Are climatic / hydrologic conditions on the site typical for this time of year? Yes No (If no, explain in Remarks.)
 Are Vegetation , Soil , or Hydrology , significantly disturbed? Are "Normal Circumstances" present? Yes No
 Are Vegetation , Soil , or Hydrology , naturally problematic? (If needed, explain any answers in Remarks.)

SUMMARY OF FINDINGS – Attach site map showing sampling point locations, transects, important features, etc.

Hydrophytic Vegetation Present?	Yes <input checked="" type="checkbox"/>	No <input type="checkbox"/>	Is the Sampled Area within a Wetland?	Yes <input checked="" type="checkbox"/>	No <input type="checkbox"/>
Hydric Soil Present?	Yes <input checked="" type="checkbox"/>	No <input type="checkbox"/>		Yes <input checked="" type="checkbox"/>	No <input type="checkbox"/>
Wetland Hydrology Present?	Yes <input checked="" type="checkbox"/>	No <input type="checkbox"/>		Yes <input checked="" type="checkbox"/>	No <input type="checkbox"/>
Remarks: Wetland is located between a city street and a residential development. The wetland includes depressional and slope HGM classes. The depressional area is adjacent to the city street fill pipism fed by the residential home slope areas. The wetland soil plot was located in the slope portion of the wetland toward the residential development.					

VEGETATION – Use scientific names of plants

Tree Stratum (Plot size: 30 foot radius)	Absolute % Cover	Dominant Species?	Indicator Status	Dominance Test Worksheet:																
1. <u><i>Pseudotsuga menziesii</i></u>	10	yes	FACU	Number of Dominant Species That Are OBL, FACW, or FAC: <u>2</u> (A) Total Number of Dominant Species Across All Strata: <u>3</u> (B) Percent of Dominant Species That Are OBL, FACW, or FAC: <u>2</u> (A/B)																
2. _____	_____	_____	_____																	
3. _____	_____	_____	_____																	
4. _____	_____	_____	_____																	
50% = <u>1</u> , 20% = _____	10	= Total Cover																		
<u>Sapling/Shrub Stratum (Plot size: 15 foot radius)</u>																				
1. <u><i>Rubus armeniacus</i></u>	5	no	FACU	Prevalence Index worksheet: <table style="width: 100%; border: none;"> <tr> <td style="text-align: center; border: none;">Total % Cover of:</td> <td style="text-align: center; border: none;">Multiply by:</td> </tr> <tr> <td style="border: none;">OBL species _____</td> <td style="border: none;">x1 = _____</td> </tr> <tr> <td style="border: none;">FACW species _____</td> <td style="border: none;">x2 = _____</td> </tr> <tr> <td style="border: none;">FAC species _____</td> <td style="border: none;">x3 = _____</td> </tr> <tr> <td style="border: none;">FACU species _____</td> <td style="border: none;">x4 = _____</td> </tr> <tr> <td style="border: none;">UPL species _____</td> <td style="border: none;">x5 = _____</td> </tr> <tr> <td style="border: none;">Column Totals: _____ (A)</td> <td style="border: none;">_____ (B)</td> </tr> <tr> <td colspan="2" style="border: none; text-align: center;">Prevalence Index = B/A = _____</td> </tr> </table>	Total % Cover of:	Multiply by:	OBL species _____	x1 = _____	FACW species _____	x2 = _____	FAC species _____	x3 = _____	FACU species _____	x4 = _____	UPL species _____	x5 = _____	Column Totals: _____ (A)	_____ (B)	Prevalence Index = B/A = _____	
Total % Cover of:	Multiply by:																			
OBL species _____	x1 = _____																			
FACW species _____	x2 = _____																			
FAC species _____	x3 = _____																			
FACU species _____	x4 = _____																			
UPL species _____	x5 = _____																			
Column Totals: _____ (A)	_____ (B)																			
Prevalence Index = B/A = _____																				
2. _____	_____	_____	_____																	
3. _____	_____	_____	_____																	
4. _____	_____	_____	_____																	
5. _____	_____	_____	_____																	
50% = <u>0</u> , 20% = <u>0</u>	5	= Total Cover																		
<u>Herb Stratum (Plot size: 3 foot radius)</u>																				
1. <u><i>Phalaris arundinacea</i></u>	30	yes	FACW	Hydrophytic Vegetation Indicators: <input type="checkbox"/> 1 – Rapid Test for Hydrophytic Vegetation <input checked="" type="checkbox"/> 2 - Dominance Test is >50% <input type="checkbox"/> 3 - Prevalence Index is ≤3.0 ¹ <input type="checkbox"/> 4 - Morphological Adaptations ¹ (Provide supporting data in Remarks or on a separate sheet) <input type="checkbox"/> 5 - Wetland Non-Vascular Plants ¹ <input type="checkbox"/> Problematic Hydrophytic Vegetation ¹ (Explain) ¹ Indicators of hydric soil and wetland hydrology must be present, unless disturbed or problematic.																
2. <u><i>Veronica americana</i></u>	30	yes	OBL																	
3. <u><i>Carex obnupta</i></u>	10	no	OBL																	
4. <u><i>Urtica dioica</i></u>	5	no	FAC																	
5. <u><i>Athyrium filix-femina</i></u>	10	no	FAC																	
6. <u><i>Equisetum arvense</i></u>	10	no	FAC																	
7. _____	_____	_____	_____																	
8. _____	_____	_____	_____																	
9. _____	_____	_____	_____																	
10. _____	_____	_____	_____																	
11. _____	_____	_____	_____																	
50% = <u>0</u> , 20% = <u>2</u>	95	= Total Cover																		
<u>Woody Vine Stratum (Plot size: 3 foot radius)</u>																				
1. _____	_____	_____	_____	Hydrophytic Vegetation Present? Yes <input checked="" type="checkbox"/> No <input type="checkbox"/>																
2. _____	_____	_____	_____																	
50% = _____, 20% = _____	0	= Total Cover																		
% Bare Ground in Herb Stratum <u>0</u>																				

Remarks: The area is dominated by emergent vegetation and evidence of woody vegetation cutting and trimming is evident.

SOIL

Profile Description: (Describe to the depth needed to document the indicator or confirm the absence of indicators.)

Depth (inches)	Matrix		Redox Features				Texture	Remarks
	Color (moist)	%	Color (moist)	%	Type ¹	Loc ²		
0 to 1	10YR 2/1	100	None	None	None	None	Silt	Silt with fine to coarse root matt.
1-18+	10YR 2/1	100						Some sand and fine gravel and rock
_____	_____	_____	_____	_____	_____	_____	_____	_____
_____	_____	_____	_____	_____	_____	_____	_____	_____
_____	_____	_____	_____	_____	_____	_____	_____	_____
_____	_____	_____	_____	_____	_____	_____	_____	_____
_____	_____	_____	_____	_____	_____	_____	_____	_____

¹Type: C= Concentration, D=Depletion, RM=Reduced Matrix, CS=Covered or Coated Sand Grains. ²Location: PL=Pore Lining, M=Matrix

Hydric Soil Indicators: (Applicable to all LRRs, unless otherwise noted.)

- Histosol (A1)
- Histic Epipedon (A2)
- Black Histic (A3)
- Hydrogen Sulfide (A4)
- Depleted Below Dark Surface (A11)
- Thick Dark Surface (A12)
- Sandy Mucky Mineral (S1)
- Sandy Gleyed Matrix (S4)
- Sandy Redox (S5)
- Stripped Matrix (S6)
- Loamy Mucky Mineral (F1) **(except MLRA 1)**
- Loamy Gleyed Matrix (F2)
- Depleted Matrix (F3)
- Redox Dark Surface (F6)
- Depleted Dark Surface (F7)
- Redox Depressions (F8)

Indicators for Problematic Hydric Soils³:

- 2 cm Muck (A10)
- Red Parent Material (TF2)
- Very Shallow Dark Surface (TF12)
- Other (Explain in Remarks)

³Indicators of hydrophytic vegetation and wetland hydrology must be present, unless disturbed or problematic.

Restrictive Layer (if present):

Type: _____
 Depth (inches): _____

Hydric Soils Present? Yes No

Remarks: 2 chroma with no redox features

HYDROLOGY

Wetland Hydrology Indicators:

Primary Indicators (minimum of one required; check all that apply)

Secondary Indicators (2 or more required)

- | | | |
|--|---|--|
| <input checked="" type="checkbox"/> Surface Water (A1) | <input type="checkbox"/> Water-Stained Leaves (B9) | <input type="checkbox"/> Water-Stained Leaves (B9) |
| <input checked="" type="checkbox"/> High Water Table (A2) | (except MLRA 1, 2, 4A, and 4B) | (MLRA 1, 2, 4A, and 4B) |
| <input checked="" type="checkbox"/> Saturation (A3) | <input type="checkbox"/> Salt Crust (B11) | <input type="checkbox"/> Drainage Patterns (B10) |
| <input type="checkbox"/> Water Marks (B1) | <input type="checkbox"/> Aquatic Invertebrates (B13) | <input type="checkbox"/> Dry-Season Water Table (C2) |
| <input type="checkbox"/> Sediment Deposits (B2) | <input checked="" type="checkbox"/> Hydrogen Sulfide Odor (C1) | <input type="checkbox"/> Saturation Visible on Aerial Imagery (C9) |
| <input type="checkbox"/> Drift Deposits (B3) | <input type="checkbox"/> Oxidized Rhizospheres along Living Roots (C3) | <input type="checkbox"/> Geomorphic Position (D2) |
| <input type="checkbox"/> Algal Mat or Crust (B4) | <input type="checkbox"/> Presence of Reduced Iron (C4) | <input type="checkbox"/> Shallow Aquitard (D3) |
| <input type="checkbox"/> Iron Deposits (B5) | <input type="checkbox"/> Recent Iron Reduction in Tilled Soils (C6) | <input type="checkbox"/> FAC-Neutral Test (D5) |
| <input type="checkbox"/> Surface Soil Cracks (B6) | <input type="checkbox"/> Stunted or Stresses Plants (D1) (LRR A) | <input type="checkbox"/> Raised Ant Mounds (D6) (LRR A) |
| <input type="checkbox"/> Inundation Visible on Aerial Imagery (B7) | <input type="checkbox"/> Other (Explain in Remarks) | <input type="checkbox"/> Frost-Heave Hummocks (D7) |
| <input type="checkbox"/> Sparsely Vegetated Concave Surface (B8) | | |

Field Observations:

Surface Water Present? Yes No Depth (inches): _____
 Water Table Present? Yes No Depth (inches): 15
 Saturation Present? (includes capillary fringe) Yes No Depth (inches): _____

Wetland Hydrology Present? Yes No

Describe Recorded Data (stream gauge, monitoring well, aerial photos, previous inspections), if available:

Remarks: Surface water present within the wetland but not at the soil plot.

WETLAND DETERMINATION DATA FORM – Western Mountains, Valleys, and Coast Region

Project Site: Sound Transit East Link Extension Project City/County: Bellevue/King Sampling Date: April 6, 2013
 Applicant/Owner: Sound Transit State: WA Sampling Point: Alcove Creek SPU
 Investigator(s): C Douglas & J. Pursley Section, Township, Range: S5, T24N, R5E
 Landform (hillslope, terrace, etc.): Riparian, ponded, slope Local relief (concave, convex, none): concave Slope (%): 0% to 4%
 Subregion (LRR): A Lat: 47.59N Long: 122.19W Datum: _____
 Soil Map Unit Name: AqC & Sk NWI classification: None mapped
 Are climatic / hydrologic conditions on the site typical for this time of year? Yes No (If no, explain in Remarks.)
 Are Vegetation , Soil , or Hydrology , significantly disturbed? Are "Normal Circumstances" present? Yes No
 Are Vegetation , Soil , or Hydrology , naturally problematic? (If needed, explain any answers in Remarks.)

SUMMARY OF FINDINGS – Attach site map showing sampling point locations, transects, important features, etc.

Hydrophytic Vegetation Present?	Yes <input type="checkbox"/>	No <input checked="" type="checkbox"/>	Is the Sampled Area within a Wetland?	Yes <input type="checkbox"/>	No <input checked="" type="checkbox"/>
Hydric Soil Present?	Yes <input type="checkbox"/>	No <input checked="" type="checkbox"/>		Yes <input type="checkbox"/>	No <input checked="" type="checkbox"/>
Wetland Hydrology Present?	Yes <input type="checkbox"/>	No <input checked="" type="checkbox"/>		Yes <input type="checkbox"/>	No <input checked="" type="checkbox"/>
Remarks: Wetland is located adjacent to residential development and public roads. Wetland includes depressional and riverine HGM classes. Depressional area is pond like feature within apartment setting.					

VEGETATION – Use scientific names of plants

Tree Stratum (Plot size: 30 foot radius)	Absolute % Cover	Dominant Species?	Indicator Status	Dominance Test Worksheet:																																
1. <u>Abies grandis</u>	<u>5</u>	<u>no</u>	<u>FACU</u>	Number of Dominant Species That Are OBL, FACW, or FAC: <u>1</u> (A) Total Number of Dominant Species Across All Strata: <u>4</u> (B) Percent of Dominant Species That Are OBL, FACW, or FAC: <u>25</u> (A/B)																																
2. <u>Fraxinus latifolia</u>	<u>75</u>	<u>yes</u>	<u>FACW</u>																																	
3. <u>Pinus monticola</u>	<u>5</u>	<u>no</u>	<u>FACU</u>																																	
4. _____	_____	_____	_____																																	
50% = <u>1</u> , 20% = <u>0</u>	<u>85</u>	= Total Cover																																		
<u>Sapling/Shrub Stratum (Plot size: 15 foot radius)</u>																																				
1. <u>Rubus armeniacus</u>	<u>40</u>	<u>yes</u>	<u>FACU</u>	Prevalence Index worksheet: <table style="width: 100%; border: none;"> <tr> <td style="text-align: right;">Total % Cover of:</td> <td style="width: 20px;">_____</td> <td style="text-align: right;">Multiply by:</td> <td style="width: 20px;">_____</td> </tr> <tr> <td>OBL species</td> <td>_____</td> <td>x1 =</td> <td>_____</td> </tr> <tr> <td>FACW species</td> <td>_____</td> <td>x2 =</td> <td>_____</td> </tr> <tr> <td>FAC species</td> <td>_____</td> <td>x3 =</td> <td>_____</td> </tr> <tr> <td>FACU species</td> <td>_____</td> <td>x4 =</td> <td>_____</td> </tr> <tr> <td>UPL species</td> <td>_____</td> <td>x5 =</td> <td>_____</td> </tr> <tr> <td>Column Totals:</td> <td>_____ (A)</td> <td></td> <td>_____ (B)</td> </tr> <tr> <td colspan="4" style="text-align: center;">Prevalence Index = B/A = _____</td> </tr> </table>	Total % Cover of:	_____	Multiply by:	_____	OBL species	_____	x1 =	_____	FACW species	_____	x2 =	_____	FAC species	_____	x3 =	_____	FACU species	_____	x4 =	_____	UPL species	_____	x5 =	_____	Column Totals:	_____ (A)		_____ (B)	Prevalence Index = B/A = _____			
Total % Cover of:	_____	Multiply by:	_____																																	
OBL species	_____	x1 =	_____																																	
FACW species	_____	x2 =	_____																																	
FAC species	_____	x3 =	_____																																	
FACU species	_____	x4 =	_____																																	
UPL species	_____	x5 =	_____																																	
Column Totals:	_____ (A)		_____ (B)																																	
Prevalence Index = B/A = _____																																				
2. <u>Symphoricarpos albus</u>	<u>45</u>	<u>yes</u>	<u>FACU</u>																																	
3. _____	_____	_____	_____																																	
4. _____	_____	_____	_____																																	
5. _____	_____	_____	_____																																	
50% = <u>1</u> , 20% = <u>1</u>	<u>95</u>	= Total Cover																																		
<u>Herb Stratum (Plot size: 3 foot radius)</u>																																				
1. _____	_____	_____	_____	Hydrophytic Vegetation Indicators: <input type="checkbox"/> 1 – Rapid Test for Hydrophytic Vegetation <input type="checkbox"/> 2 - Dominance Test is >50% <input type="checkbox"/> 3 - Prevalence Index is $\leq 3.0^1$ <input type="checkbox"/> 4 - Morphological Adaptations ¹ (Provide supporting data in Remarks or on a separate sheet) <input type="checkbox"/> 5 - Wetland Non-Vascular Plants ¹ <input type="checkbox"/> Problematic Hydrophytic Vegetation ¹ (Explain) ¹ Indicators of hydric soil and wetland hydrology must be present, unless disturbed or problematic.																																
2. _____	_____	_____	_____																																	
3. _____	_____	_____	_____																																	
4. _____	_____	_____	_____																																	
5. _____	_____	_____	_____																																	
6. _____	_____	_____	_____																																	
7. _____	_____	_____	_____																																	
8. _____	_____	_____	_____																																	
9. _____	_____	_____	_____																																	
10. _____	_____	_____	_____																																	
11. _____	_____	_____	_____																																	
50% = <u>1</u> , 20% = <u>0</u>	<u>0</u>	= Total Cover																																		
<u>Woody Vine Stratum (Plot size: 3 foot radius)</u>																																				
1. <u>Hedera hibernica</u>	<u>10</u>	<u>yes</u>	<u>UPL</u>	Hydrophytic Vegetation Present? <table style="width: 100%; border: none;"> <tr> <td style="width: 30px;">Yes</td> <td style="width: 20px;"><input type="checkbox"/></td> <td style="width: 30px;">No</td> <td style="width: 20px;"><input checked="" type="checkbox"/></td> </tr> </table>	Yes	<input type="checkbox"/>	No	<input checked="" type="checkbox"/>																												
Yes	<input type="checkbox"/>	No	<input checked="" type="checkbox"/>																																	
2. _____	_____	_____	_____																																	
50% = _____, 20% = _____	<u>0</u>	= Total Cover																																		
% Bare Ground in Herb Stratum <u>100</u>																																				

Remarks: 25% dominant wetland vegetation per the Dominance Test

SOIL

Profile Description: (Describe to the depth needed to document the indicator or confirm the absence of indicators.)								
Depth (inches)	Matrix		Redox Features				Texture	Remarks
	Color (moist)	%	Color (moist)	%	Type ¹	Loc ²		
0 to 18+	10YR 2/2	100	None	None	None	None	Sandy loam	w/gravel & cobble
_____	_____	_____	_____	_____	_____	_____	_____	_____
_____	_____	_____	_____	_____	_____	_____	_____	_____
_____	_____	_____	_____	_____	_____	_____	_____	_____
_____	_____	_____	_____	_____	_____	_____	_____	_____
_____	_____	_____	_____	_____	_____	_____	_____	_____
_____	_____	_____	_____	_____	_____	_____	_____	_____
¹ Type: C= Concentration, D=Depletion, RM=Reduced Matrix, CS=Covered or Coated Sand Grains.			² Location: PL=Pore Lining, M=Matrix					
Hydric Soil Indicators: (Applicable to all LRRs, unless otherwise noted.)						Indicators for Problematic Hydric Soils³:		
<input type="checkbox"/> Histosol (A1)			<input type="checkbox"/> Sandy Redox (S5)			<input type="checkbox"/> 2 cm Muck (A10)		
<input type="checkbox"/> Histic Epipedon (A2)			<input type="checkbox"/> Stripped Matrix (S6)			<input type="checkbox"/> Red Parent Material (TF2)		
<input type="checkbox"/> Black Histic (A3)			<input type="checkbox"/> Loamy Mucky Mineral (F1) (except MLRA 1)			<input type="checkbox"/> Very Shallow Dark Surface (TF12)		
<input type="checkbox"/> Hydrogen Sulfide (A4)			<input type="checkbox"/> Loamy Gleyed Matrix (F2)			<input type="checkbox"/> Other (Explain in Remarks)		
<input type="checkbox"/> Depleted Below Dark Surface (A11)			<input type="checkbox"/> Depleted Matrix (F3)			³ Indicators of hydrophytic vegetation and wetland hydrology must be present, unless disturbed or problematic.		
<input type="checkbox"/> Thick Dark Surface (A12)			<input type="checkbox"/> Redox Dark Surface (F6)					
<input type="checkbox"/> Sandy Mucky Mineral (S1)			<input type="checkbox"/> Depleted Dark Surface (F7)					
<input type="checkbox"/> Sandy Gleyed Matrix (S4)			<input type="checkbox"/> Redox Depressions (F8)					
Restrictive Layer (if present):								
Type: _____						Yes <input type="checkbox"/> No <input checked="" type="checkbox"/>		
Depth (inches): _____								
Remarks: 2 chroma with no redox features								

HYDROLOGY

Wetland Hydrology Indicators:			
Primary Indicators (minimum of one required; check all that apply)		Secondary Indicators (2 or more required)	
<input type="checkbox"/> Surface Water (A1)	<input type="checkbox"/> Water-Stained Leaves (B9)	<input type="checkbox"/> Water-Stained Leaves (B9)	
<input type="checkbox"/> High Water Table (A2)	(except MLRA 1, 2, 4A, and 4B)	(MLRA 1, 2, 4A, and 4B)	
<input type="checkbox"/> Saturation (A3)	<input type="checkbox"/> Salt Crust (B11)	<input type="checkbox"/> Drainage Patterns (B10)	
<input type="checkbox"/> Water Marks (B1)	<input type="checkbox"/> Aquatic Invertebrates (B13)	<input type="checkbox"/> Dry-Season Water Table (C2)	
<input type="checkbox"/> Sediment Deposits (B2)	<input type="checkbox"/> Hydrogen Sulfide Odor (C1)	<input type="checkbox"/> Saturation Visible on Aerial Imagery (C9)	
<input type="checkbox"/> Drift Deposits (B3)	<input type="checkbox"/> Oxidized Rhizospheres along Living Roots (C3)	<input type="checkbox"/> Geomorphic Position (D2)	
<input type="checkbox"/> Algal Mat or Crust (B4)	<input type="checkbox"/> Presence of Reduced Iron (C4)	<input type="checkbox"/> Shallow Aquitard (D3)	
<input type="checkbox"/> Iron Deposits (B5)	<input type="checkbox"/> Recent Iron Reduction in Tilled Soils (C6)	<input type="checkbox"/> FAC-Neutral Test (D5)	
<input type="checkbox"/> Surface Soil Cracks (B6)	<input type="checkbox"/> Stunted or Stresses Plants (D1) (LRR A)	<input type="checkbox"/> Raised Ant Mounds (D6) (LRR A)	
<input type="checkbox"/> Inundation Visible on Aerial Imagery (B7)	<input type="checkbox"/> Other (Explain in Remarks)	<input type="checkbox"/> Frost-Heave Hummocks (D7)	
<input type="checkbox"/> Sparsely Vegetated Concave Surface (B8)			
Field Observations:		Wetland Hydrology Present?	
Surface Water Present?	Yes <input type="checkbox"/> No <input checked="" type="checkbox"/>	Yes <input type="checkbox"/> No <input checked="" type="checkbox"/>	
Water Table Present?	Yes <input type="checkbox"/> No <input checked="" type="checkbox"/>		
Saturation Present? (includes capillary fringe)	Yes <input type="checkbox"/> No <input checked="" type="checkbox"/>		
Describe Recorded Data (stream gauge, monitoring well, aerial photos, previous inspections), if available:			
Remarks: No saturation or water table observed in sample plot			

WETLAND DETERMINATION DATA FORM – Western Mountains, Valleys, and Coast Region

Project Site: Sound Transit East Link Extension Project City/County: Bellevue/King Sampling Date: April 4, 2013
 Applicant/Owner: Sound Transit State: WA Sampling Point: Alcove Creek SPW
 Investigator(s): C Douglas & J. Pursley Section, Township, Range: S5, T24N, R5E
 Landform (hillslope, terrace, etc.): Riparian, ponded, slope Local relief (concave, convex, none): concave Slope (%): 0% to 4%
 Subregion (LRR): A Lat: 47.59N Long: 122.19W Datum: _____
 Soil Map Unit Name: AgC & Sk NWI classification: None mapped
 Are climatic / hydrologic conditions on the site typical for this time of year? Yes No (If no, explain in Remarks.)
 Are Vegetation , Soil , or Hydrology , significantly disturbed? Are "Normal Circumstances" present? Yes No
 Are Vegetation , Soil , or Hydrology , naturally problematic? (If needed, explain any answers in Remarks.)

SUMMARY OF FINDINGS – Attach site map showing sampling point locations, transects, important features, etc.

Hydrophytic Vegetation Present?	Yes <input checked="" type="checkbox"/>	No <input type="checkbox"/>	Is the Sampled Area within a Wetland?	Yes <input checked="" type="checkbox"/>	No <input type="checkbox"/>
Hydric Soil Present?	Yes <input checked="" type="checkbox"/>	No <input type="checkbox"/>		Yes <input checked="" type="checkbox"/>	No <input type="checkbox"/>
Wetland Hydrology Present?	Yes <input checked="" type="checkbox"/>	No <input type="checkbox"/>		Yes <input checked="" type="checkbox"/>	No <input type="checkbox"/>
Remarks: Wetland is located adjacent to residential development and public roads. Wetland includes depressional and riverine HGM classes. Depressional area is pond like feature within apartment setting.					

VEGETATION – Use scientific names of plants

Tree Stratum (Plot size: 30 foot radius)	Absolute % Cover	Dominant Species?	Indicator Status	Dominance Test Worksheet:																
1. <u><i>Alnus rubra</i></u>	<u>5</u>	<u>no</u>	<u>FAC</u>	Number of Dominant Species That Are OBL, FACW, or FAC: <u>2</u> (A) Total Number of Dominant Species Across All Strata: <u>3</u> (B) Percent of Dominant Species That Are OBL, FACW, or FAC: <u>67</u> (A/B)																
2. <u><i>Fraxinus latifolia</i></u>	<u>5</u>	<u>no</u>	<u>FACW</u>																	
3. <u><i>Populus trichocarpa</i></u>	<u>85</u>	<u>yes</u>	<u>FAC</u>																	
4. _____	_____	_____	_____																	
50% = <u>1</u> , 20% = <u>0</u>	<u>95</u>	= Total Cover		Prevalence Index worksheet: <table style="width: 100%; border: none;"> <tr> <td style="text-align: right;">Total % Cover of:</td> <td style="text-align: left;">Multiply by:</td> </tr> <tr> <td>OBL species _____</td> <td>x1 = _____</td> </tr> <tr> <td>FACW species _____</td> <td>x2 = _____</td> </tr> <tr> <td>FAC species _____</td> <td>x3 = _____</td> </tr> <tr> <td>FACU species _____</td> <td>x4 = _____</td> </tr> <tr> <td>UPL species _____</td> <td>x5 = _____</td> </tr> <tr> <td>Column Totals: _____ (A)</td> <td>_____ (B)</td> </tr> <tr> <td colspan="2" style="text-align: center;">Prevalence Index = B/A = _____</td> </tr> </table>	Total % Cover of:	Multiply by:	OBL species _____	x1 = _____	FACW species _____	x2 = _____	FAC species _____	x3 = _____	FACU species _____	x4 = _____	UPL species _____	x5 = _____	Column Totals: _____ (A)	_____ (B)	Prevalence Index = B/A = _____	
Total % Cover of:	Multiply by:																			
OBL species _____	x1 = _____																			
FACW species _____	x2 = _____																			
FAC species _____	x3 = _____																			
FACU species _____	x4 = _____																			
UPL species _____	x5 = _____																			
Column Totals: _____ (A)	_____ (B)																			
Prevalence Index = B/A = _____																				
Sapling/Shrub Stratum (Plot size: 15 foot radius)																				
1. <u><i>Cornus sericea</i></u>	<u>30</u>	<u>yes</u>	<u>FACW</u>	Hydrophytic Vegetation Indicators: <input type="checkbox"/> 1 – Rapid Test for Hydrophytic Vegetation <input checked="" type="checkbox"/> 2 - Dominance Test is >50% <input type="checkbox"/> 3 - Prevalence Index is $\leq 3.0^1$ <input type="checkbox"/> 4 - Morphological Adaptations ¹ (Provide supporting data in Remarks or on a separate sheet) <input type="checkbox"/> 5 - Wetland Non-Vascular Plants ¹ <input type="checkbox"/> Problematic Hydrophytic Vegetation ¹ (Explain) ¹ Indicators of hydric soil and wetland hydrology must be present, unless disturbed or problematic.																
2. <u><i>Lonicera involucrata</i></u>	<u>5</u>	<u>no</u>	<u>FAC</u>																	
3. <u><i>Oemleria cerasiformis</i></u>	<u>20</u>	<u>yes</u>	<u>FACU</u>																	
4. <u><i>Rubus armeniacus</i></u>	<u>10</u>	<u>no</u>	<u>FACU</u>																	
5. _____	_____	_____	_____																	
50% = <u>0</u> , 20% = <u>2</u>	<u>65</u>	= Total Cover																		
Herb Stratum (Plot size: 3 foot radius)																				
1. _____	_____	_____	_____																	
2. _____	_____	_____	_____																	
3. _____	_____	_____	_____																	
4. _____	_____	_____	_____																	
5. _____	_____	_____	_____																	
6. _____	_____	_____	_____																	
7. _____	_____	_____	_____																	
8. _____	_____	_____	_____																	
9. _____	_____	_____	_____																	
10. _____	_____	_____	_____																	
11. _____	_____	_____	_____																	
50% = <u>0</u> , 20% = <u>0</u>	<u>0</u>	= Total Cover																		
Woody Vine Stratum (Plot size: 3 foot radius)																				
1. _____	_____	_____	_____																	
2. _____	_____	_____	_____																	
50% = _____, 20% = _____	<u>0</u>	= Total Cover																		
% Bare Ground in Herb Stratum <u>100</u>																				

Remarks: 67% dominant wetland vegetation per the Dominance Test

SOIL

Profile Description: (Describe to the depth needed to document the indicator or confirm the absence of indicators.)

Depth (inches)	Matrix		Redox Features				Texture	Remarks
	Color (moist)	%	Color (moist)	%	Type ¹	Loc ²		
0 to 1	Duff	100	None	None	None	None	Duff	w/leaf litter
1 to 18+	10YR 3/1	100	None	None	None	None	Silt loam	w/dense organic material
_____	_____	_____	_____	_____	_____	_____	_____	_____
_____	_____	_____	_____	_____	_____	_____	_____	_____
_____	_____	_____	_____	_____	_____	_____	_____	_____
_____	_____	_____	_____	_____	_____	_____	_____	_____
_____	_____	_____	_____	_____	_____	_____	_____	_____

¹Type: C= Concentration, D=Depletion, RM=Reduced Matrix, CS=Covered or Coated Sand Grains. ²Location: PL=Pore Lining, M=Matrix

Hydric Soil Indicators: (Applicable to all LRRs, unless otherwise noted.)

- Histosol (A1)
- Histic Epipedon (A2)
- Black Histic (A3)
- Hydrogen Sulfide (A4)
- Depleted Below Dark Surface (A11)
- Thick Dark Surface (A12)
- Sandy Mucky Mineral (S1)
- Sandy Gleyed Matrix (S4)
- Sandy Redox (S5)
- Stripped Matrix (S6)
- Loamy Mucky Mineral (F1) **(except MLRA 1)**
- Loamy Gleyed Matrix (F2)
- Depleted Matrix (F3)
- Redox Dark Surface (F6)
- Depleted Dark Surface (F7)
- Redox Depressions (F8)

Indicators for Problematic Hydric Soils³:

- 2 cm Muck (A10)
- Red Parent Material (TF2)
- Very Shallow Dark Surface (TF12)
- Other (Explain in Remarks)

³Indicators of hydrophytic vegetation and wetland hydrology must be present, unless disturbed or problematic.

Restrictive Layer (if present):

Type: _____
 Depth (inches): _____

Hydric Soils Present? Yes No

Remarks: 1 chroma

HYDROLOGY

Wetland Hydrology Indicators:

Primary Indicators (minimum of one required; check all that apply)

- Surface Water (A1)
- High Water Table (A2)
- Saturation (A3)
- Water Marks (B1)
- Sediment Deposits (B2)
- Drift Deposits (B3)
- Algal Mat or Crust (B4)
- Iron Deposits (B5)
- Surface Soil Cracks (B6)
- Inundation Visible on Aerial Imagery (B7)
- Sparsely Vegetated Concave Surface (B8)
- Water-Stained Leaves (B9) **(except MLRA 1, 2, 4A, and 4B)**
- Salt Crust (B11)
- Aquatic Invertebrates (B13)
- Hydrogen Sulfide Odor (C1)
- Oxidized Rhizospheres along Living Roots (C3)
- Presence of Reduced Iron (C4)
- Recent Iron Reduction in Tilled Soils (C6)
- Stunted or Stresses Plants (D1) **(LRR A)**
- Other (Explain in Remarks)

Secondary Indicators (2 or more required)

- Water-Stained Leaves (B9) **(MLRA 1, 2, 4A, and 4B)**
- Drainage Patterns (B10)
- Dry-Season Water Table (C2)
- Saturation Visible on Aerial Imagery (C9)
- Geomorphic Position (D2)
- Shallow Aquitard (D3)
- FAC-Neutral Test (D5)
- Raised Ant Mounds (D6) **(LRR A)**
- Frost-Heave Hummocks (D7)

Field Observations:

Surface Water Present? Yes No Depth (inches): _____
 Water Table Present? Yes No Depth (inches): 5 inches
 Saturation Present? (includes capillary fringe) Yes No Depth (inches): Surface

Wetland Hydrology Present? Yes No

Describe Recorded Data (stream gauge, monitoring well, aerial photos, previous inspections), if available:

Remarks: Saturation and water table observed in sample plot

WETLAND DETERMINATION DATA FORM – Western Mountains, Valleys, and Coast Region

Project Site: Sound Transit East Link Extension Project City/County: Bellevue/King Sampling Date: May 17, 2013
 Applicant/Owner: Sound Transit State: WA Sampling Point: Bellefield North SPU
 Investigator(s): C Douglas & J. Pursley Section, Township, Range: S5, T24N, R5E
 Landform (hillslope, terrace, etc.): Riparian slope Local relief (concave, convex, none): concave Slope (%): 0% to 4%
 Subregion (LRR): A Lat: 47.59N Long: 122.19W Datum: _____
 Soil Map Unit Name: AqC & Sk NWI classification: None mapped
 Are climatic / hydrologic conditions on the site typical for this time of year? Yes No (If no, explain in Remarks.)
 Are Vegetation , Soil , or Hydrology , significantly disturbed? Are "Normal Circumstances" present? Yes No
 Are Vegetation , Soil , or Hydrology , naturally problematic? (If needed, explain any answers in Remarks.)

SUMMARY OF FINDINGS – Attach site map showing sampling point locations, transects, important features, etc.

Hydrophytic Vegetation Present?	Yes <input checked="" type="checkbox"/>	No <input type="checkbox"/>	Is the Sampled Area within a Wetland?	Yes <input type="checkbox"/>	No <input checked="" type="checkbox"/>
Hydric Soil Present?	Yes <input type="checkbox"/>	No <input checked="" type="checkbox"/>		Yes <input type="checkbox"/>	No <input checked="" type="checkbox"/>
Wetland Hydrology Present?	Yes <input type="checkbox"/>	No <input checked="" type="checkbox"/>		Yes <input type="checkbox"/>	No <input checked="" type="checkbox"/>
Remarks: Wetland is located between Mercer Slough and 12th Avenue SE. Wetland Bellefield South is located south of the wetland. Area between roads is dominated by mowed grass and thick growth of Himalayan blackberry. Wetland includes riverine and slope HGM classes.					

VEGETATION – Use scientific names of plants

Tree Stratum (Plot size: 30 foot radius)	Absolute % Cover	Dominant Species?	Indicator Status	Dominance Test Worksheet:																
1. <u><i>Populus trichocarpa</i></u>	<u>5</u>	<u>yes</u>	<u>FAC</u>	Number of Dominant Species That Are OBL, FACW, or FAC: <u>2</u> (A) Total Number of Dominant Species Across All Strata: <u>4</u> (B) Percent of Dominant Species That Are OBL, FACW, or FAC: <u>50</u> (A/B)																
2. _____	_____	_____	_____																	
3. _____	_____	_____	_____																	
4. _____	_____	_____	_____																	
50% = <u>1</u> , 20% = <u>0</u>	<u>5</u>	= Total Cover		Prevalence Index worksheet: <table style="width: 100%; border: none;"> <tr> <td style="text-align: right;">Total % Cover of:</td> <td style="text-align: left;">Multiply by:</td> </tr> <tr> <td>OBL species _____</td> <td>x1 = _____</td> </tr> <tr> <td>FACW species _____</td> <td>x2 = _____</td> </tr> <tr> <td>FAC species _____</td> <td>x3 = _____</td> </tr> <tr> <td>FACU species _____</td> <td>x4 = _____</td> </tr> <tr> <td>UPL species _____</td> <td>x5 = _____</td> </tr> <tr> <td>Column Totals: _____ (A)</td> <td>_____ (B)</td> </tr> <tr> <td colspan="2" style="text-align: center;">Prevalence Index = B/A = _____</td> </tr> </table>	Total % Cover of:	Multiply by:	OBL species _____	x1 = _____	FACW species _____	x2 = _____	FAC species _____	x3 = _____	FACU species _____	x4 = _____	UPL species _____	x5 = _____	Column Totals: _____ (A)	_____ (B)	Prevalence Index = B/A = _____	
Total % Cover of:	Multiply by:																			
OBL species _____	x1 = _____																			
FACW species _____	x2 = _____																			
FAC species _____	x3 = _____																			
FACU species _____	x4 = _____																			
UPL species _____	x5 = _____																			
Column Totals: _____ (A)	_____ (B)																			
Prevalence Index = B/A = _____																				
Sapling/Shrub Stratum (Plot size: 15 foot radius)																				
1. <u><i>Rubus armeniacus</i></u>	<u>80</u>	<u>yes</u>	<u>FACU</u>	Hydrophytic Vegetation Indicators: <input type="checkbox"/> 1 – Rapid Test for Hydrophytic Vegetation <input checked="" type="checkbox"/> 2 - Dominance Test is >50% <input type="checkbox"/> 3 - Prevalence Index is $\leq 3.0^1$ <input type="checkbox"/> 4 - Morphological Adaptations ¹ (Provide supporting data in Remarks or on a separate sheet) <input type="checkbox"/> 5 - Wetland Non-Vascular Plants ¹ <input type="checkbox"/> Problematic Hydrophytic Vegetation ¹ (Explain) ¹ Indicators of hydric soil and wetland hydrology must be present, unless disturbed or problematic.																
2. <u><i>Sambucus racemosa</i></u>	<u>20</u>	<u>yes</u>	<u>FACU</u>																	
3. _____	_____	_____	_____																	
4. _____	_____	_____	_____																	
5. _____	_____	_____	_____																	
50% = <u>1</u> , 20% = <u>1</u>	<u>100</u>	= Total Cover																		
Herb Stratum (Plot size: 3 foot radius)																				
1. <u><i>Urtica dioica</i></u>	<u>60</u>	<u>yes</u>	<u>FAC</u>	Hydrophytic Vegetation Present? Yes <input checked="" type="checkbox"/> No <input type="checkbox"/>																
2. _____	_____	_____	_____																	
3. _____	_____	_____	_____																	
4. _____	_____	_____	_____																	
5. _____	_____	_____	_____																	
6. _____	_____	_____	_____																	
7. _____	_____	_____	_____																	
8. _____	_____	_____	_____																	
9. _____	_____	_____	_____																	
10. _____	_____	_____	_____																	
11. _____	_____	_____	_____																	
50% = <u>1</u> , 20% = <u>0</u>	<u>60</u>	= Total Cover																		
Woody Vine Stratum (Plot size: 3 foot radius)																				
1. _____	_____	_____	_____	Hydrophytic Vegetation Present? Yes <input checked="" type="checkbox"/> No <input type="checkbox"/>																
2. _____	_____	_____	_____																	
50% = _____, 20% = _____	<u>0</u>	= Total Cover																		
% Bare Ground in Herb Stratum <u>40</u>																				

Remarks: 50% dominant wetland vegetation per the Dominance Test

SOIL

Profile Description: (Describe to the depth needed to document the indicator or confirm the absence of indicators.)								
Depth (inches)	Matrix		Redox Features				Texture	Remarks
	Color (moist)	%	Color (moist)	%	Type ¹	Loc ²		
0 to 12	<u>10YR 3/4</u>	<u>100</u>	<u>None</u>	<u>None</u>	<u>None</u>	<u>None</u>	<u>Loam</u>	<u>w/brick & charcoal pieces</u>
0 to 12	<u>10YR 5/4</u>	<u>100</u>	<u>None</u>	<u>None</u>	<u>None</u>	<u>None</u>	<u>Loam</u>	<u>w/brick & charcoal pieces</u>
12 to 18+	<u>10YR 2/2</u>	<u>100</u>	<u>None</u>	<u>None</u>	<u>None</u>	<u>None</u>	<u>Loam</u>	_____
_____	_____	_____	_____	_____	_____	_____	_____	_____
_____	_____	_____	_____	_____	_____	_____	_____	_____
_____	_____	_____	_____	_____	_____	_____	_____	_____
_____	_____	_____	_____	_____	_____	_____	_____	_____
¹ Type: C= Concentration, D=Depletion, RM=Reduced Matrix, CS=Covered or Coated Sand Grains. ² Location: PL=Pore Lining, M=Matrix								
Hydric Soil Indicators: (Applicable to all LRRs, unless otherwise noted.)						Indicators for Problematic Hydric Soils³:		
<input type="checkbox"/> Histosol (A1)			<input type="checkbox"/> Sandy Redox (S5)			<input type="checkbox"/> 2 cm Muck (A10)		
<input type="checkbox"/> Histic Epipedon (A2)			<input type="checkbox"/> Stripped Matrix (S6)			<input type="checkbox"/> Red Parent Material (TF2)		
<input type="checkbox"/> Black Histic (A3)			<input type="checkbox"/> Loamy Mucky Mineral (F1) (except MLRA 1)			<input type="checkbox"/> Very Shallow Dark Surface (TF12)		
<input type="checkbox"/> Hydrogen Sulfide (A4)			<input type="checkbox"/> Loamy Gleyed Matrix (F2)			<input type="checkbox"/> Other (Explain in Remarks)		
<input type="checkbox"/> Depleted Below Dark Surface (A11)			<input type="checkbox"/> Depleted Matrix (F3)			³ Indicators of hydrophytic vegetation and wetland hydrology must be present, unless disturbed or problematic.		
<input type="checkbox"/> Thick Dark Surface (A12)			<input type="checkbox"/> Redox Dark Surface (F6)					
<input type="checkbox"/> Sandy Mucky Mineral (S1)			<input type="checkbox"/> Depleted Dark Surface (F7)					
<input type="checkbox"/> Sandy Gleyed Matrix (S4)			<input type="checkbox"/> Redox Depressions (F8)					
<input type="checkbox"/> Restrictive Layer (if present):			<input type="checkbox"/> Restrictive Layer (if present):					
Type: _____			Type: _____			Type: _____		
Depth (inches): _____			Depth (inches): _____			Depth (inches): _____		
Remarks: 2 and 4 chroma with no redox features						Hydric Soils Present? Yes <input type="checkbox"/> No <input checked="" type="checkbox"/>		

HYDROLOGY

Wetland Hydrology Indicators:			
Primary Indicators (minimum of one required; check all that apply)		Secondary Indicators (2 or more required)	
<input type="checkbox"/> Surface Water (A1)	<input type="checkbox"/> Water-Stained Leaves (B9)	<input type="checkbox"/> Water-Stained Leaves (B9)	<input type="checkbox"/> Water-Stained Leaves (B9)
<input type="checkbox"/> High Water Table (A2)	(except MLRA 1, 2, 4A, and 4B)	(MLRA 1, 2, 4A, and 4B)	
<input type="checkbox"/> Saturation (A3)	<input type="checkbox"/> Salt Crust (B11)	<input type="checkbox"/> Drainage Patterns (B10)	<input type="checkbox"/> Drainage Patterns (B10)
<input type="checkbox"/> Water Marks (B1)	<input type="checkbox"/> Aquatic Invertebrates (B13)	<input type="checkbox"/> Dry-Season Water Table (C2)	<input type="checkbox"/> Dry-Season Water Table (C2)
<input type="checkbox"/> Sediment Deposits (B2)	<input type="checkbox"/> Hydrogen Sulfide Odor (C1)	<input type="checkbox"/> Saturation Visible on Aerial Imagery (C9)	<input type="checkbox"/> Saturation Visible on Aerial Imagery (C9)
<input type="checkbox"/> Drift Deposits (B3)	<input type="checkbox"/> Oxidized Rhizospheres along Living Roots (C3)	<input type="checkbox"/> Geomorphic Position (D2)	<input type="checkbox"/> Geomorphic Position (D2)
<input type="checkbox"/> Algal Mat or Crust (B4)	<input type="checkbox"/> Presence of Reduced Iron (C4)	<input type="checkbox"/> Shallow Aquitard (D3)	<input type="checkbox"/> Shallow Aquitard (D3)
<input type="checkbox"/> Iron Deposits (B5)	<input type="checkbox"/> Recent Iron Reduction in Tilled Soils (C6)	<input type="checkbox"/> FAC-Neutral Test (D5)	<input type="checkbox"/> FAC-Neutral Test (D5)
<input type="checkbox"/> Surface Soil Cracks (B6)	<input type="checkbox"/> Stunted or Stresses Plants (D1) (LRR A)	<input type="checkbox"/> Raised Ant Mounds (D6) (LRR A)	<input type="checkbox"/> Raised Ant Mounds (D6) (LRR A)
<input type="checkbox"/> Inundation Visible on Aerial Imagery (B7)	<input type="checkbox"/> Other (Explain in Remarks)	<input type="checkbox"/> Frost-Heave Hummocks (D7)	<input type="checkbox"/> Frost-Heave Hummocks (D7)
<input type="checkbox"/> Sparsely Vegetated Concave Surface (B8)			
Field Observations:		Wetland Hydrology Present?	
Surface Water Present?	Yes <input type="checkbox"/> No <input checked="" type="checkbox"/>	Depth (inches): _____	Yes <input type="checkbox"/> No <input checked="" type="checkbox"/>
Water Table Present?	Yes <input type="checkbox"/> No <input checked="" type="checkbox"/>	Depth (inches): _____	
Saturation Present? (includes capillary fringe)	Yes <input type="checkbox"/> No <input checked="" type="checkbox"/>	Depth (inches): _____	
Describe Recorded Data (stream gauge, monitoring well, aerial photos, previous inspections), if available:			
Remarks: No saturation or water table observed in sample plot			

WETLAND DETERMINATION DATA FORM – Western Mountains, Valleys, and Coast Region

Project Site: Sound Transit East Link Extension Project City/County: Bellevue/King Sampling Date: May 17, 2013
 Applicant/Owner: Sound Transit State: WA Sampling Point: Bellefield North SPW
 Investigator(s): C Douglas & J. Pursley Section, Township, Range: S5, T24N, R5E
 Landform (hillslope, terrace, etc.): Riparian slope Local relief (concave, convex, none): concave Slope (%): 0% to 4%
 Subregion (LRR): A Lat: 47.59N Long: 122.19W Datum: _____
 Soil Map Unit Name: AqC & Sk NWI classification: None mapped
 Are climatic / hydrologic conditions on the site typical for this time of year? Yes No (If no, explain in Remarks.)
 Are Vegetation , Soil , or Hydrology , significantly disturbed? Are "Normal Circumstances" present? Yes No
 Are Vegetation , Soil , or Hydrology , naturally problematic? (If needed, explain any answers in Remarks.)

SUMMARY OF FINDINGS – Attach site map showing sampling point locations, transects, important features, etc.

Hydrophytic Vegetation Present?	Yes <input checked="" type="checkbox"/>	No <input type="checkbox"/>	Is the Sampled Area within a Wetland?	Yes <input checked="" type="checkbox"/>	No <input type="checkbox"/>
Hydric Soil Present?	Yes <input checked="" type="checkbox"/>	No <input type="checkbox"/>		Yes <input checked="" type="checkbox"/>	No <input type="checkbox"/>
Wetland Hydrology Present?	Yes <input checked="" type="checkbox"/>	No <input type="checkbox"/>		Yes <input checked="" type="checkbox"/>	No <input type="checkbox"/>
Remarks: Wetland is located between Mercer Slough and 12 th Avenue SE. Wetland Bellefield South is located south of the wetland. Area between roads is dominated by mowed grass and thick growth of Himalayan blackberry. Wetland includes riverine and slope HGM classes.					

VEGETATION – Use scientific names of plants

Tree Stratum (Plot size: 30 foot radius)	Absolute % Cover	Dominant Species?	Indicator Status	Dominance Test Worksheet:																
1. <u>Fraxinus latifolia</u>	<u>70</u>	<u>yes</u>	<u>FACW</u>	Number of Dominant Species That Are OBL, FACW, or FAC: <u>4</u> (A) Total Number of Dominant Species Across All Strata: <u>5</u> (B) Percent of Dominant Species That Are OBL, FACW, or FAC: <u>80</u> (A/B)																
2. <u>Populus trichocarpa</u>	<u>40</u>	<u>yes</u>	<u>FAC</u>																	
3. _____	_____	_____	_____																	
4. _____	_____	_____	_____																	
50% = <u>1</u> , 20% = <u>1</u>	<u>100</u>	= Total Cover																		
Sapling/Shrub Stratum (Plot size: 15 foot radius)	Absolute % Cover	Dominant Species?	Indicator Status	Prevalence Index worksheet:																
1. <u>Cornus sericea</u>	<u>40</u>	<u>yes</u>	<u>FACU</u>	<table style="width: 100%; border-collapse: collapse;"> <thead> <tr> <th style="width: 60%;">Total % Cover of:</th> <th style="width: 40%;">Multiply by:</th> </tr> </thead> <tbody> <tr> <td>OBL species _____</td> <td>x1 = _____</td> </tr> <tr> <td>FACW species _____</td> <td>x2 = _____</td> </tr> <tr> <td>FAC species _____</td> <td>x3 = _____</td> </tr> <tr> <td>FACU species _____</td> <td>x4 = _____</td> </tr> <tr> <td>UPL species _____</td> <td>x5 = _____</td> </tr> <tr> <td>Column Totals: _____ (A)</td> <td>_____ (B)</td> </tr> <tr> <td colspan="2" style="text-align: center;">Prevalence Index = B/A = _____</td> </tr> </tbody> </table>	Total % Cover of:	Multiply by:	OBL species _____	x1 = _____	FACW species _____	x2 = _____	FAC species _____	x3 = _____	FACU species _____	x4 = _____	UPL species _____	x5 = _____	Column Totals: _____ (A)	_____ (B)	Prevalence Index = B/A = _____	
Total % Cover of:	Multiply by:																			
OBL species _____	x1 = _____																			
FACW species _____	x2 = _____																			
FAC species _____	x3 = _____																			
FACU species _____	x4 = _____																			
UPL species _____	x5 = _____																			
Column Totals: _____ (A)	_____ (B)																			
Prevalence Index = B/A = _____																				
2. <u>Rubus armeniacus</u>	<u>30</u>	<u>yes</u>	<u>FACU</u>																	
3. _____	_____	_____	_____																	
4. _____	_____	_____	_____																	
5. _____	_____	_____	_____																	
50% = <u>1</u> , 20% = <u>1</u>	<u>70</u>	= Total Cover																		
Herb Stratum (Plot size: 3 foot radius)	Absolute % Cover	Dominant Species?	Indicator Status	Hydrophytic Vegetation Indicators:																
1. <u>Urtica dioica</u>	<u>20</u>	<u>yes</u>	<u>FAC</u>	<input type="checkbox"/> 1 – Rapid Test for Hydrophytic Vegetation <input checked="" type="checkbox"/> 2 - Dominance Test is >50% <input type="checkbox"/> 3 - Prevalence Index is ≤3.0 ¹ <input type="checkbox"/> 4 - Morphological Adaptations ¹ (Provide supporting data in Remarks or on a separate sheet) <input type="checkbox"/> 5 - Wetland Non-Vascular Plants ¹ <input type="checkbox"/> Problematic Hydrophytic Vegetation ¹ (Explain) ¹ Indicators of hydric soil and wetland hydrology must be present, unless disturbed or problematic.																
2. _____	_____	_____	_____																	
3. _____	_____	_____	_____																	
4. _____	_____	_____	_____																	
5. _____	_____	_____	_____																	
6. _____	_____	_____	_____																	
7. _____	_____	_____	_____																	
8. _____	_____	_____	_____																	
9. _____	_____	_____	_____																	
10. _____	_____	_____	_____																	
11. _____	_____	_____	_____																	
50% = <u>1</u> , 20% = <u>0</u>	<u>20</u>	= Total Cover																		
Woody Vine Stratum (Plot size: 3 foot radius)	Absolute % Cover	Dominant Species?	Indicator Status	Hydrophytic Vegetation Present?																
1. _____	_____	_____	_____	Yes <input checked="" type="checkbox"/> No <input type="checkbox"/>																
2. _____	_____	_____	_____																	
50% = _____, 20% = _____	<u>0</u>	= Total Cover																		
% Bare Ground in Herb Stratum <u>80</u>																				

Remarks: 80% dominant wetland vegetation per the Dominance Test

SOIL

Profile Description: (Describe to the depth needed to document the indicator or confirm the absence of indicators.)								
Depth (inches)	Matrix		Redox Features				Texture	Remarks
	Color (moist)	%	Color (moist)	%	Type ¹	Loc ²		
0 to 18+	10YR 2/1	100	None	None	None	None	Loam	
¹ Type: C= Concentration, D=Depletion, RM=Reduced Matrix, CS=Covered or Coated Sand Grains. ² Location: PL=Pore Lining, M=Matrix								
Hydric Soil Indicators: (Applicable to all LRRs, unless otherwise noted.)						Indicators for Problematic Hydric Soils³:		
<input type="checkbox"/>	Histosol (A1)		<input type="checkbox"/>	Sandy Redox (S5)		<input type="checkbox"/>	2 cm Muck (A10)	
<input type="checkbox"/>	Histic Epipedon (A2)		<input type="checkbox"/>	Stripped Matrix (S6)		<input type="checkbox"/>	Red Parent Material (TF2)	
<input type="checkbox"/>	Black Histic (A3)		<input type="checkbox"/>	Loamy Mucky Mineral (F1) (except MLRA 1)		<input type="checkbox"/>	Very Shallow Dark Surface (TF12)	
<input type="checkbox"/>	Hydrogen Sulfide (A4)		<input type="checkbox"/>	Loamy Gleyed Matrix (F2)		<input type="checkbox"/>	Other (Explain in Remarks)	
<input type="checkbox"/>	Depleted Below Dark Surface (A11)		<input type="checkbox"/>	Depleted Matrix (F3)		³ Indicators of hydrophytic vegetation and wetland hydrology must be present, unless disturbed or problematic.		
<input checked="" type="checkbox"/>	Thick Dark Surface (A12)		<input type="checkbox"/>	Redox Dark Surface (F6)				
<input type="checkbox"/>	Sandy Mucky Mineral (S1)		<input type="checkbox"/>	Depleted Dark Surface (F7)				
<input type="checkbox"/>	Sandy Gleyed Matrix (S4)		<input type="checkbox"/>	Redox Depressions (F8)				
Restrictive Layer (if present):						Hydric Soils Present?		
Type: _____						Yes <input checked="" type="checkbox"/> No <input type="checkbox"/>		
Depth (inches): _____								
Remarks: 1 chroma								

HYDROLOGY

Wetland Hydrology Indicators:			
Primary Indicators (minimum of one required; check all that apply)		Secondary Indicators (2 or more required)	
<input type="checkbox"/>	Surface Water (A1)	<input checked="" type="checkbox"/>	Water-Stained Leaves (B9)
<input type="checkbox"/>	High Water Table (A2)	(except MLRA 1, 2, 4A, and 4B)	
<input checked="" type="checkbox"/>	Saturation (A3)	<input type="checkbox"/>	Salt Crust (B11)
<input type="checkbox"/>	Water Marks (B1)	<input type="checkbox"/>	Aquatic Invertebrates (B13)
<input type="checkbox"/>	Sediment Deposits (B2)	<input type="checkbox"/>	Hydrogen Sulfide Odor (C1)
<input type="checkbox"/>	Drift Deposits (B3)	<input type="checkbox"/>	Oxidized Rhizospheres along Living Roots (C3)
<input type="checkbox"/>	Algal Mat or Crust (B4)	<input type="checkbox"/>	Presence of Reduced Iron (C4)
<input type="checkbox"/>	Iron Deposits (B5)	<input type="checkbox"/>	Recent Iron Reduction in Tilled Soils (C6)
<input type="checkbox"/>	Surface Soil Cracks (B6)	<input type="checkbox"/>	Stunted or Stresses Plants (D1) (LRR A)
<input type="checkbox"/>	Inundation Visible on Aerial Imagery (B7)	<input type="checkbox"/>	Other (Explain in Remarks)
<input type="checkbox"/>	Sparsely Vegetated Concave Surface (B8)	<input type="checkbox"/>	Water-Stained Leaves (B9)
		(MLRA 1, 2, 4A, and 4B)	
		<input type="checkbox"/>	Drainage Patterns (B10)
		<input type="checkbox"/>	Dry-Season Water Table (C2)
		<input type="checkbox"/>	Saturation Visible on Aerial Imagery (C9)
		<input type="checkbox"/>	Geomorphic Position (D2)
		<input type="checkbox"/>	Shallow Aquitard (D3)
		<input type="checkbox"/>	FAC-Neutral Test (D5)
		<input type="checkbox"/>	Raised Ant Mounds (D6) (LRR A)
		<input type="checkbox"/>	Frost-Heave Hummocks (D7)
Field Observations:			
Surface Water Present?	Yes <input type="checkbox"/> No <input checked="" type="checkbox"/>	Depth (inches):	_____
Water Table Present?	Yes <input type="checkbox"/> No <input checked="" type="checkbox"/>	Depth (inches):	_____
Saturation Present? (includes capillary fringe)	Yes <input checked="" type="checkbox"/> No <input type="checkbox"/>	Depth (inches):	6 inches
		Wetland Hydrology Present? Yes <input checked="" type="checkbox"/> No <input type="checkbox"/>	
Describe Recorded Data (stream gauge, monitoring well, aerial photos, previous inspections), if available:			
Remarks: Saturation observed at 6 inches in sample plot			

WETLAND DETERMINATION DATA FORM – Western Mountains, Valleys, and Coast Region

Project Site: Sound Transit East Link Extension Project City/County: Bellevue/King Sampling Date: May 17, 2013
 Applicant/Owner: Sound Transit State: WA Sampling Point: Bellefield South SPU
 Investigator(s): C Douglas & J. Pursley Section, Township, Range: S5, T24N, R5E
 Landform (hillslope, terrace, etc.): Riparian slope Local relief (concave, convex, none): concave Slope (%): 0% to 4%
 Subregion (LRR): A Lat: 47.59N Long: 122.19W Datum: _____
 Soil Map Unit Name: AgC & Sk NWI classification: None mapped
 Are climatic / hydrologic conditions on the site typical for this time of year? Yes No (If no, explain in Remarks.)
 Are Vegetation , Soil , or Hydrology , significantly disturbed? Are "Normal Circumstances" present? Yes No
 Are Vegetation , Soil , or Hydrology , naturally problematic? (If needed, explain any answers in Remarks.)

SUMMARY OF FINDINGS – Attach site map showing sampling point locations, transects, important features, etc.

Hydrophytic Vegetation Present?	Yes <input type="checkbox"/>	No <input checked="" type="checkbox"/>	Is the Sampled Area within a Wetland?	Yes <input type="checkbox"/>	No <input checked="" type="checkbox"/>
Hydric Soil Present?	Yes <input type="checkbox"/>	No <input checked="" type="checkbox"/>		Yes <input type="checkbox"/>	No <input checked="" type="checkbox"/>
Wetland Hydrology Present?	Yes <input type="checkbox"/>	No <input checked="" type="checkbox"/>		Yes <input type="checkbox"/>	No <input checked="" type="checkbox"/>
Remarks: Wetland is located between Mercer Slough and 12th Avenue SE with SE 15th Street to the south. Wetland Bellefield North is located north of the wetland. Area between roads is dominated by mowed grass and thick growth of Himalayan blackberry. Wetland includes riverine and slope HGM classes.					

VEGETATION – Use scientific names of plants

Tree Stratum (Plot size: 30 foot radius)	Absolute % Cover	Dominant Species?	Indicator Status	Dominance Test Worksheet:																
1. _____	_____	_____	_____	Number of Dominant Species That Are OBL, FACW, or FAC: 1 (A) Total Number of Dominant Species Across All Strata: 3 (B) Percent of Dominant Species That Are OBL, FACW, or FAC: 33 (A/B)																
2. _____	_____	_____	_____																	
3. _____	_____	_____	_____																	
4. _____	_____	_____	_____																	
50% = 0, 20% = 0	_____	= Total Cover		Prevalence Index worksheet: <table style="width: 100%; border: none;"> <tr> <td style="text-align: center;">Total % Cover of:</td> <td style="text-align: center;">Multiply by:</td> </tr> <tr> <td>OBL species _____</td> <td>x1 = _____</td> </tr> <tr> <td>FACW species _____</td> <td>x2 = _____</td> </tr> <tr> <td>FAC species _____</td> <td>x3 = _____</td> </tr> <tr> <td>FACU species _____</td> <td>x4 = _____</td> </tr> <tr> <td>UPL species _____</td> <td>x5 = _____</td> </tr> <tr> <td>Column Totals: _____ (A)</td> <td>_____ (B)</td> </tr> <tr> <td colspan="2" style="text-align: center;">Prevalence Index = B/A = _____</td> </tr> </table>	Total % Cover of:	Multiply by:	OBL species _____	x1 = _____	FACW species _____	x2 = _____	FAC species _____	x3 = _____	FACU species _____	x4 = _____	UPL species _____	x5 = _____	Column Totals: _____ (A)	_____ (B)	Prevalence Index = B/A = _____	
Total % Cover of:	Multiply by:																			
OBL species _____	x1 = _____																			
FACW species _____	x2 = _____																			
FAC species _____	x3 = _____																			
FACU species _____	x4 = _____																			
UPL species _____	x5 = _____																			
Column Totals: _____ (A)	_____ (B)																			
Prevalence Index = B/A = _____																				
Sapling/Shrub Stratum (Plot size: 15 foot radius)																				
1. <u>Rubus armeniacus</u>	10	yes	FACU																	
2. _____	_____	_____	_____																	
3. _____	_____	_____	_____																	
4. _____	_____	_____	_____																	
5. _____	_____	_____	_____																	
50% = 1, 20% = 0	10	= Total Cover																		
Herb Stratum (Plot size: 3 foot radius)																				
1. <u>Urtica dioica</u>	70	yes	FAC																	
2. _____	_____	_____	_____																	
3. _____	_____	_____	_____																	
4. _____	_____	_____	_____																	
5. _____	_____	_____	_____																	
6. _____	_____	_____	_____																	
7. _____	_____	_____	_____																	
8. _____	_____	_____	_____																	
9. _____	_____	_____	_____																	
10. _____	_____	_____	_____																	
11. _____	_____	_____	_____																	
50% = 1, 20% = 0	10	= Total Cover																		
Woody Vine Stratum (Plot size: 3 foot radius)																				
1. <u>Convolvulus arvensis</u>	40	yes	UPL																	
2. _____	_____	_____	_____																	
50% = 1, 20% = _____	40	= Total Cover																		
% Bare Ground in Herb Stratum 90																				

Hydrophytic Vegetation Indicators:

1 – Rapid Test for Hydrophytic Vegetation

2 - Dominance Test is >50%

3 - Prevalence Index is $\leq 3.0^1$

4 - Morphological Adaptations¹ (Provide supporting data in Remarks or on a separate sheet)

5 - Wetland Non-Vascular Plants¹

Problematic Hydrophytic Vegetation¹ (Explain)

¹Indicators of hydric soil and wetland hydrology must be present, unless disturbed or problematic.

Hydrophytic Vegetation Present? Yes No

Remarks: 33% dominant wetland vegetation per the Dominance Test

SOIL

Profile Description: (Describe to the depth needed to document the indicator or confirm the absence of indicators.)

Depth (inches)	Matrix		Redox Features				Texture	Remarks
	Color (moist)	%	Color (moist)	%	Type ¹	Loc ²		
0 to 15	10YR 2/2	100	None	None	None	None	Loam	
15 to 18+	10YR 2/2	100	None	None	None	None	Loam	w/coarse organic material
_____	_____	_____	_____	_____	_____	_____	_____	_____
_____	_____	_____	_____	_____	_____	_____	_____	_____
_____	_____	_____	_____	_____	_____	_____	_____	_____
_____	_____	_____	_____	_____	_____	_____	_____	_____
_____	_____	_____	_____	_____	_____	_____	_____	_____

¹Type: C= Concentration, D=Depletion, RM=Reduced Matrix, CS=Covered or Coated Sand Grains. ²Location: PL=Pore Lining, M=Matrix

Hydric Soil Indicators: (Applicable to all LRRs, unless otherwise noted.) <input type="checkbox"/> Histosol (A1) <input type="checkbox"/> Histic Epipedon (A2) <input type="checkbox"/> Black Histic (A3) <input type="checkbox"/> Hydrogen Sulfide (A4) <input type="checkbox"/> Depleted Below Dark Surface (A11) <input type="checkbox"/> Thick Dark Surface (A12) <input type="checkbox"/> Sandy Mucky Mineral (S1) <input type="checkbox"/> Sandy Gleyed Matrix (S4)		<input type="checkbox"/> Sandy Redox (S5) <input type="checkbox"/> Stripped Matrix (S6) <input type="checkbox"/> Loamy Mucky Mineral (F1) (except MLRA 1) <input type="checkbox"/> Loamy Gleyed Matrix (F2) <input type="checkbox"/> Depleted Matrix (F3) <input type="checkbox"/> Redox Dark Surface (F6) <input type="checkbox"/> Depleted Dark Surface (F7) <input type="checkbox"/> Redox Depressions (F8)		Indicators for Problematic Hydric Soils³: <input type="checkbox"/> 2 cm Muck (A10) <input type="checkbox"/> Red Parent Material (TF2) <input type="checkbox"/> Very Shallow Dark Surface (TF12) <input type="checkbox"/> Other (Explain in Remarks)	
--	--	--	--	---	--

³Indicators of hydrophytic vegetation and wetland hydrology must be present, unless disturbed or problematic.

Restrictive Layer (if present): Type: _____ Depth (inches): _____	Hydric Soils Present? Yes <input type="checkbox"/> No <input checked="" type="checkbox"/>
--	--

Remarks: 2 chroma with no redox features

HYDROLOGY

Wetland Hydrology Indicators: Primary Indicators (minimum of one required; check all that apply)		Secondary Indicators (2 or more required)	
<input type="checkbox"/> Surface Water (A1) <input type="checkbox"/> High Water Table (A2) <input type="checkbox"/> Saturation (A3) <input type="checkbox"/> Water Marks (B1) <input type="checkbox"/> Sediment Deposits (B2) <input type="checkbox"/> Drift Deposits (B3) <input type="checkbox"/> Algal Mat or Crust (B4) <input type="checkbox"/> Iron Deposits (B5) <input type="checkbox"/> Surface Soil Cracks (B6) <input type="checkbox"/> Inundation Visible on Aerial Imagery (B7) <input type="checkbox"/> Sparsely Vegetated Concave Surface (B8)	<input type="checkbox"/> Water-Stained Leaves (B9) (except MLRA 1, 2, 4A, and 4B) <input type="checkbox"/> Salt Crust (B11) <input type="checkbox"/> Aquatic Invertebrates (B13) <input type="checkbox"/> Hydrogen Sulfide Odor (C1) <input type="checkbox"/> Oxidized Rhizospheres along Living Roots (C3) <input type="checkbox"/> Presence of Reduced Iron (C4) <input type="checkbox"/> Recent Iron Reduction in Tilled Soils (C6) <input type="checkbox"/> Stunted or Stresses Plants (D1) (LRR A) <input type="checkbox"/> Other (Explain in Remarks)	<input type="checkbox"/> Water-Stained Leaves (B9) (MLRA 1, 2, 4A, and 4B) <input type="checkbox"/> Drainage Patterns (B10) <input type="checkbox"/> Dry-Season Water Table (C2) <input type="checkbox"/> Saturation Visible on Aerial Imagery (C9) <input type="checkbox"/> Geomorphic Position (D2) <input type="checkbox"/> Shallow Aquitard (D3) <input type="checkbox"/> FAC-Neutral Test (D5) <input type="checkbox"/> Raised Ant Mounds (D6) (LRR A) <input type="checkbox"/> Frost-Heave Hummocks (D7)	

Field Observations: Surface Water Present? Yes <input type="checkbox"/> No <input checked="" type="checkbox"/> Depth (inches): _____ Water Table Present? Yes <input type="checkbox"/> No <input checked="" type="checkbox"/> Depth (inches): _____ Saturation Present? (includes capillary fringe) Yes <input type="checkbox"/> No <input checked="" type="checkbox"/> Depth (inches): _____	Wetland Hydrology Present? Yes <input type="checkbox"/> No <input checked="" type="checkbox"/>
---	---

Describe Recorded Data (stream gauge, monitoring well, aerial photos, previous inspections), if available:

Remarks: No saturation or water table observed in sample plot

WETLAND DETERMINATION DATA FORM – Western Mountains, Valleys, and Coast Region

Project Site: Sound Transit East Link Extension Project City/County: Bellevue/King Sampling Date: May 17, 2013
 Applicant/Owner: Sound Transit State: WA Sampling Point: Bellefield South SPW
 Investigator(s): C Douglas & J. Pursley Section, Township, Range: S5, T24N, R5E
 Landform (hillslope, terrace, etc.): Riparian slope Local relief (concave, convex, none): concave Slope (%): 0% to 4%
 Subregion (LRR): A Lat: 47.59N Long: 122.19W Datum: _____
 Soil Map Unit Name: AqC & Sk NWI classification: None mapped
 Are climatic / hydrologic conditions on the site typical for this time of year? Yes No (If no, explain in Remarks.)
 Are Vegetation , Soil , or Hydrology , significantly disturbed? Are "Normal Circumstances" present? Yes No
 Are Vegetation , Soil , or Hydrology , naturally problematic? (If needed, explain any answers in Remarks.)

SUMMARY OF FINDINGS – Attach site map showing sampling point locations, transects, important features, etc.

Hydrophytic Vegetation Present?	Yes <input checked="" type="checkbox"/>	No <input type="checkbox"/>	Is the Sampled Area within a Wetland?	Yes <input checked="" type="checkbox"/>	No <input type="checkbox"/>
Hydric Soil Present?	Yes <input checked="" type="checkbox"/>	No <input type="checkbox"/>		Yes <input checked="" type="checkbox"/>	No <input type="checkbox"/>
Wetland Hydrology Present?	Yes <input checked="" type="checkbox"/>	No <input type="checkbox"/>		Yes <input checked="" type="checkbox"/>	No <input type="checkbox"/>
Remarks: Wetland is located between Mercer Slough and 12 th Avenue SE with SE 15 th Street to the south. Area between roads is dominated by mowed grass and thick growth of Himalayan blackberry. Wetland includes riverine and slope HGM classes. .					

VEGETATION – Use scientific names of plants

Tree Stratum (Plot size: 30 foot radius)	Absolute % Cover	Dominant Species?	Indicator Status	Dominance Test Worksheet:
1. <u><i>Alnus rubra</i></u>	20	yes	FAC	Number of Dominant Species That Are OBL, FACW, or FAC: <u>3</u> (A) Total Number of Dominant Species Across All Strata: <u>5</u> (B) Percent of Dominant Species That Are OBL, FACW, or FAC: <u>60</u> (A/B)
2. <u><i>Fraxinus latifolia</i></u>	75	yes	FACW	
3. _____	_____	_____	_____	
4. _____	_____	_____	_____	
50% = 1, 20% = 1	95	= Total Cover		
Sapling/Shrub Stratum (Plot size: 15 foot radius)				Prevalence Index worksheet: Total % Cover of: _____ Multiply by: OBL species _____ x1 = _____ FACW species _____ x2 = _____ FAC species _____ x3 = _____ FACU species _____ x4 = _____ UPL species _____ x5 = _____ Column Totals: _____ (A) _____ (B) Prevalence Index = B/A = _____
1. <u><i>Rubus armeniacus</i></u>	10	yes	FACU	
2. _____	_____	_____	_____	
3. _____	_____	_____	_____	
4. _____	_____	_____	_____	
5. _____	_____	_____	_____	
50% = 1, 20% = 0	10	= Total Cover		
Herb Stratum (Plot size: 3 foot radius)				Hydrophytic Vegetation Indicators: <input type="checkbox"/> 1 – Rapid Test for Hydrophytic Vegetation <input checked="" type="checkbox"/> 2 - Dominance Test is >50% <input type="checkbox"/> 3 - Prevalence Index is $\leq 3.0^1$ <input type="checkbox"/> 4 - Morphological Adaptations ¹ (Provide supporting data in Remarks or on a separate sheet) <input type="checkbox"/> 5 - Wetland Non-Vascular Plants ¹ <input type="checkbox"/> Problematic Hydrophytic Vegetation ¹ (Explain) ¹ Indicators of hydric soil and wetland hydrology must be present, unless disturbed or problematic.
1. <u><i>Brassica campestris</i></u>	5	no	UPL	
2. <u><i>Epilobium watsonii</i></u>	5	no	FACW	
3. <u><i>Urtica dioica</i></u>	70	yes	FAC	
4. _____	_____	_____	_____	
5. _____	_____	_____	_____	
6. _____	_____	_____	_____	
7. _____	_____	_____	_____	
8. _____	_____	_____	_____	
9. _____	_____	_____	_____	
10. _____	_____	_____	_____	
11. _____	_____	_____	_____	
50% = 2, 20% = 0	80	= Total Cover		
Woody Vine Stratum (Plot size: 3 foot radius)				Hydrophytic Vegetation Present? Yes <input checked="" type="checkbox"/> No <input type="checkbox"/>
1. <u><i>Convolvulus arvensis</i></u>	30	_____	_____	
2. _____	_____	_____	_____	
50% = 1, 20% = _____	30	= Total Cover		
% Bare Ground in Herb Stratum <u>20</u>				

Remarks: 60% dominant wetland vegetation per the Dominance Test

SOIL

Sampling Point: Bellefield South SPW

Profile Description: (Describe to the depth needed to document the indicator or confirm the absence of indicators.)

Depth (inches)	Matrix		Redox Features				Texture	Remarks
	Color (moist)	%	Color (moist)	%	Type ¹	Loc ²		
<u>0 to 14</u>	<u>10YR 2/1</u>	<u>100</u>	<u>None</u>	<u>None</u>	<u>None</u>	<u>None</u>	<u>Loam</u>	<u>w/organic matter & brick & charcoal pieces</u>
<u>14 to 18+</u>	<u>10YR 3/3</u>	<u>100</u>	<u>None</u>	<u>None</u>	<u>None</u>	<u>None</u>	<u>Silt loam</u>	<u>w/coarse organic material</u>
_____	_____	_____	_____	_____	_____	_____	_____	_____
_____	_____	_____	_____	_____	_____	_____	_____	_____
_____	_____	_____	_____	_____	_____	_____	_____	_____
_____	_____	_____	_____	_____	_____	_____	_____	_____
_____	_____	_____	_____	_____	_____	_____	_____	_____

¹Type: C= Concentration, D=Depletion, RM=Reduced Matrix, CS=Covered or Coated Sand Grains. ²Location: PL=Pore Lining, M=Matrix

Hydric Soil Indicators: (Applicable to all LRRs, unless otherwise noted.)		Indicators for Problematic Hydric Soils³:	
<input type="checkbox"/> Histosol (A1)	<input type="checkbox"/> Sandy Redox (S5)	<input type="checkbox"/> 2 cm Muck (A10)	
<input type="checkbox"/> Histic Epipedon (A2)	<input type="checkbox"/> Stripped Matrix (S6)	<input type="checkbox"/> Red Parent Material (TF2)	
<input type="checkbox"/> Black Histic (A3)	<input type="checkbox"/> Loamy Mucky Mineral (F1) (except MLRA 1)	<input type="checkbox"/> Very Shallow Dark Surface (TF12)	
<input type="checkbox"/> Hydrogen Sulfide (A4)	<input type="checkbox"/> Loamy Gleyed Matrix (F2)	<input type="checkbox"/> Other (Explain in Remarks)	
<input type="checkbox"/> Depleted Below Dark Surface (A11)	<input type="checkbox"/> Depleted Matrix (F3)		
<input checked="" type="checkbox"/> Thick Dark Surface (A12)	<input type="checkbox"/> Redox Dark Surface (F6)		
<input type="checkbox"/> Sandy Mucky Mineral (S1)	<input type="checkbox"/> Depleted Dark Surface (F7)		
<input type="checkbox"/> Sandy Gleyed Matrix (S4)	<input type="checkbox"/> Redox Depressions (F8)		

³Indicators of hydrophytic vegetation and wetland hydrology must be present, unless disturbed or problematic.

Restrictive Layer (if present):	Hydric Soils Present?
Type: _____	Yes <input checked="" type="checkbox"/> No <input type="checkbox"/>
Depth (inches): _____	

Remarks: 1 chroma

HYDROLOGY

Wetland Hydrology Indicators:	
Primary Indicators (minimum of one required; check all that apply)	Secondary Indicators (2 or more required)
<input type="checkbox"/> Surface Water (A1)	<input checked="" type="checkbox"/> Water-Stained Leaves (B9)
<input type="checkbox"/> High Water Table (A2)	(except MLRA 1, 2, 4A, and 4B)
<input checked="" type="checkbox"/> Saturation (A3)	<input type="checkbox"/> Salt Crust (B11)
<input type="checkbox"/> Water Marks (B1)	<input type="checkbox"/> Aquatic Invertebrates (B13)
<input type="checkbox"/> Sediment Deposits (B2)	<input type="checkbox"/> Hydrogen Sulfide Odor (C1)
<input type="checkbox"/> Drift Deposits (B3)	<input type="checkbox"/> Oxidized Rhizospheres along Living Roots (C3)
<input type="checkbox"/> Algal Mat or Crust (B4)	<input type="checkbox"/> Presence of Reduced Iron (C4)
<input type="checkbox"/> Iron Deposits (B5)	<input type="checkbox"/> Recent Iron Reduction in Tilled Soils (C6)
<input type="checkbox"/> Surface Soil Cracks (B6)	<input type="checkbox"/> Stunted or Stresses Plants (D1) (LRR A)
<input type="checkbox"/> Inundation Visible on Aerial Imagery (B7)	<input type="checkbox"/> Other (Explain in Remarks)
<input type="checkbox"/> Sparsely Vegetated Concave Surface (B8)	<input type="checkbox"/> Water-Stained Leaves (B9)
	(MLRA 1, 2, 4A, and 4B)
	<input type="checkbox"/> Drainage Patterns (B10)
	<input type="checkbox"/> Dry-Season Water Table (C2)
	<input type="checkbox"/> Saturation Visible on Aerial Imagery (C9)
	<input type="checkbox"/> Geomorphic Position (D2)
	<input type="checkbox"/> Shallow Aquitard (D3)
	<input type="checkbox"/> FAC-Neutral Test (D5)
	<input type="checkbox"/> Raised Ant Mounds (D6) (LRR A)
	<input type="checkbox"/> Frost-Heave Hummocks (D7)

Field Observations:	Wetland Hydrology Present?
Surface Water Present? Yes <input type="checkbox"/> No <input checked="" type="checkbox"/> Depth (inches): _____	Yes <input checked="" type="checkbox"/> No <input type="checkbox"/>
Water Table Present? Yes <input type="checkbox"/> No <input checked="" type="checkbox"/> Depth (inches): _____	
Saturation Present? (includes capillary fringe) Yes <input checked="" type="checkbox"/> No <input type="checkbox"/> Depth (inches): <u>Surface</u>	

Describe Recorded Data (stream gauge, monitoring well, aerial photos, previous inspections), if available:

Remarks: Saturation observed at surface in sample plot

WETLAND DETERMINATION DATA FORM – Western Mountains, Valleys, and Coast Region

Project Site: Sound Transit East Link Extension Project City/County: Bellevue/King Sampling Date: Feb. 14, 2013
 Applicant/Owner: Sound Transit State: WA Sampling Point: BNSF East SPU
 Investigator(s): C Douglas & J. Pursley Section, Township, Range: S29, T24N, R5E
 Landform (hillslope, terrace, etc.): Narrow area between development Local relief (concave, convex, none): concave Slope (%): 0% to 2%
 Subregion (LRR): A Lat: 47.62N Long: 122.18W Datum: _____
 Soil Map Unit Name: Kitsap silt loam NWI classification: None Mapped
 Are climatic / hydrologic conditions on the site typical for this time of year? Yes No (If no, explain in Remarks.)
 Are Vegetation , Soil , or Hydrology , significantly disturbed? Are "Normal Circumstances" present? Yes No
 Are Vegetation , Soil , or Hydrology , naturally problematic? (If needed, explain any answers in Remarks.)

SUMMARY OF FINDINGS – Attach site map showing sampling point locations, transects, important features, etc.

Hydrophytic Vegetation Present?	Yes <input checked="" type="checkbox"/>	No <input type="checkbox"/>	Is the Sampled Area within a Wetland?	Yes <input type="checkbox"/>	No <input checked="" type="checkbox"/>
Hydric Soil Present?	Yes <input type="checkbox"/>	No <input checked="" type="checkbox"/>		Yes <input type="checkbox"/>	No <input checked="" type="checkbox"/>
Wetland Hydrology Present?	Yes <input type="checkbox"/>	No <input checked="" type="checkbox"/>		Yes <input type="checkbox"/>	No <input checked="" type="checkbox"/>
Remarks: Wetland BNSF East is located in narrow area between railroad tracks and development. Wetland is a narrow depression with culverts at both ends. Wetland includes depressional HGM class.					

VEGETATION – Use scientific names of plants

Tree Stratum (Plot size: 30 foot radius)	Absolute % Cover	Dominant Species?	Indicator Status	Dominance Test Worksheet:																
1. <u><i>Alnus rubra</i></u>	<u>5</u>	<u>yes</u>	<u>FAC</u>	Number of Dominant Species That Are OBL, FACW, or FAC: <u>2</u> (A) Total Number of Dominant Species Across All Strata: <u>2</u> (B) Percent of Dominant Species That Are OBL, FACW, or FAC: <u>100</u> (A/B)																
2. _____	_____	_____	_____																	
3. _____	_____	_____	_____																	
4. _____	_____	_____	_____																	
50% = <u>1</u> , 20% = <u>0</u>	<u>5</u>	= Total Cover																		
<u>Sapling/Shrub Stratum (Plot size: 15 foot radius)</u>				Prevalence Index worksheet: <table style="width: 100%; border: none;"> <tr> <td style="text-align: right;">Total % Cover of:</td> <td style="text-align: right;">Multiply by:</td> </tr> <tr> <td>OBL species _____</td> <td>x1 = _____</td> </tr> <tr> <td>FACW species _____</td> <td>x2 = _____</td> </tr> <tr> <td>FAC species _____</td> <td>x3 = _____</td> </tr> <tr> <td>FACU species _____</td> <td>x4 = _____</td> </tr> <tr> <td>UPL species _____</td> <td>x5 = _____</td> </tr> <tr> <td>Column Totals: _____ (A)</td> <td>_____ (B)</td> </tr> <tr> <td colspan="2" style="text-align: center;">Prevalence Index = B/A = _____</td> </tr> </table>	Total % Cover of:	Multiply by:	OBL species _____	x1 = _____	FACW species _____	x2 = _____	FAC species _____	x3 = _____	FACU species _____	x4 = _____	UPL species _____	x5 = _____	Column Totals: _____ (A)	_____ (B)	Prevalence Index = B/A = _____	
Total % Cover of:	Multiply by:																			
OBL species _____	x1 = _____																			
FACW species _____	x2 = _____																			
FAC species _____	x3 = _____																			
FACU species _____	x4 = _____																			
UPL species _____	x5 = _____																			
Column Totals: _____ (A)	_____ (B)																			
Prevalence Index = B/A = _____																				
1. _____	_____	_____	_____																	
2. _____	_____	_____	_____																	
3. _____	_____	_____	_____																	
4. _____	_____	_____	_____																	
5. _____	_____	_____	_____																	
50% = <u>0</u> , 20% = <u>0</u>	<u>0</u>	= Total Cover																		
<u>Herb Stratum (Plot size: 3 foot radius)</u>				Hydrophytic Vegetation Indicators: <input type="checkbox"/> 1 – Rapid Test for Hydrophytic Vegetation <input checked="" type="checkbox"/> 2 - Dominance Test is >50% <input type="checkbox"/> 3 - Prevalence Index is $\leq 3.0^1$ <input type="checkbox"/> 4 - Morphological Adaptations ¹ (Provide supporting data in Remarks or on a separate sheet) <input type="checkbox"/> 5 - Wetland Non-Vascular Plants ¹ <input type="checkbox"/> Problematic Hydrophytic Vegetation ¹ (Explain) ¹ Indicators of hydric soil and wetland hydrology must be present, unless disturbed or problematic.																
1. <u><i>Agrostis capillaris</i></u>	<u>50</u>	<u>yes</u>	<u>FAC</u>																	
2. <u><i>Festuca rubra</i></u>	<u>15</u>	<u>no</u>	<u>FAC</u>																	
3. <u><i>Juncus effusus</i></u>	<u>10</u>	<u>no</u>	<u>FACW</u>																	
4. _____	_____	_____	_____																	
5. _____	_____	_____	_____																	
6. _____	_____	_____	_____																	
7. _____	_____	_____	_____																	
8. _____	_____	_____	_____																	
9. _____	_____	_____	_____																	
10. _____	_____	_____	_____																	
11. _____	_____	_____	_____																	
50% = <u>1</u> , 20% = <u>0</u>	<u>75</u>	= Total Cover																		
<u>Woody Vine Stratum (Plot size: 3 foot radius)</u>				Hydrophytic Vegetation Present? <table style="width: 100%; border: none;"> <tr> <td style="width: 30%;">Yes</td> <td style="width: 10%; text-align: center;"><input checked="" type="checkbox"/></td> <td style="width: 30%;">No</td> <td style="width: 10%; text-align: center;"><input type="checkbox"/></td> </tr> </table>	Yes	<input checked="" type="checkbox"/>	No	<input type="checkbox"/>												
Yes	<input checked="" type="checkbox"/>	No	<input type="checkbox"/>																	
1. <u><i>Hedera hibernica</i></u>	_____	_____	_____																	
2. _____	_____	_____	_____																	
50% = _____, 20% = _____	<u>0</u>	= Total Cover																		
% Bare Ground in Herb Stratum <u>25</u>																				

Remarks: 100% dominant wetland vegetation per the Dominance Test, only 2 dominant species.

SOIL

Profile Description: (Describe to the depth needed to document the indicator or confirm the absence of indicators.)								
Depth (inches)	Matrix		Redox Features				Texture	Remarks
	Color (moist)	%	Color (moist)	%	Type ¹	Loc ²		
0 to 4	10YR 5/4	100	None	None	None	None	Clay loam	
4 to 18+	10YR 5/4	100	None	None	None	None	Clay loam	w/cobble & gravel
____	____	____	____	____	____	____	____	____
____	____	____	____	____	____	____	____	____
____	____	____	____	____	____	____	____	____
____	____	____	____	____	____	____	____	____

¹Type: C= Concentration, D=Depletion, RM=Reduced Matrix, CS=Covered or Coated Sand Grains. ²Location: PL=Pore Lining, M=Matrix

Hydric Soil Indicators: (Applicable to all LRRs, unless otherwise noted.)		Indicators for Problematic Hydric Soils ³ :	
<input type="checkbox"/> Histosol (A1)	<input type="checkbox"/> Sandy Redox (S5)	<input type="checkbox"/> 2 cm Muck (A10)	
<input type="checkbox"/> Histic Epipedon (A2)	<input type="checkbox"/> Stripped Matrix (S6)	<input type="checkbox"/> Red Parent Material (TF2)	
<input type="checkbox"/> Black Histic (A3)	<input type="checkbox"/> Loamy Mucky Mineral (F1) (except MLRA 1)	<input type="checkbox"/> Very Shallow Dark Surface (TF12)	
<input type="checkbox"/> Hydrogen Sulfide (A4)	<input type="checkbox"/> Loamy Gleyed Matrix (F2)	<input type="checkbox"/> Other (Explain in Remarks)	
<input type="checkbox"/> Depleted Below Dark Surface (A11)	<input type="checkbox"/> Depleted Matrix (F3)		
<input type="checkbox"/> Thick Dark Surface (A12)	<input type="checkbox"/> Redox Dark Surface (F6)		
<input type="checkbox"/> Sandy Mucky Mineral (S1)	<input type="checkbox"/> Depleted Dark Surface (F7)		
<input type="checkbox"/> Sandy Gleyed Matrix (S4)	<input type="checkbox"/> Redox Depressions (F8)		

³Indicators of hydrophytic vegetation and wetland hydrology must be present, unless disturbed or problematic.

Restrictive Layer (if present): Type: <u>Fill prism</u> Depth (inches): <u>At surface</u>		Hydric Soils Present? Yes <input type="checkbox"/> No <input checked="" type="checkbox"/>	
Remarks: 4 chroma			

HYDROLOGY

Wetland Hydrology Indicators:			
Primary Indicators (minimum of one required; check all that apply)		Secondary Indicators (2 or more required)	
<input type="checkbox"/> Surface Water (A1)	<input type="checkbox"/> Water-Stained Leaves (B9)	<input type="checkbox"/> Water-Stained Leaves (B9)	
<input type="checkbox"/> High Water Table (A2)	(except MLRA 1, 2, 4A, and 4B)	(MLRA 1, 2, 4A, and 4B)	
<input type="checkbox"/> Saturation (A3)	<input type="checkbox"/> Salt Crust (B11)	<input type="checkbox"/> Drainage Patterns (B10)	
<input type="checkbox"/> Water Marks (B1)	<input type="checkbox"/> Aquatic Invertebrates (B13)	<input type="checkbox"/> Dry-Season Water Table (C2)	
<input type="checkbox"/> Sediment Deposits (B2)	<input type="checkbox"/> Hydrogen Sulfide Odor (C1)	<input type="checkbox"/> Saturation Visible on Aerial Imagery (C9)	
<input type="checkbox"/> Drift Deposits (B3)	<input type="checkbox"/> Oxidized Rhizospheres along Living Roots (C3)	<input type="checkbox"/> Geomorphic Position (D2)	
<input type="checkbox"/> Algal Mat or Crust (B4)	<input type="checkbox"/> Presence of Reduced Iron (C4)	<input type="checkbox"/> Shallow Aquitard (D3)	
<input type="checkbox"/> Iron Deposits (B5)	<input type="checkbox"/> Recent Iron Reduction in Tilled Soils (C6)	<input type="checkbox"/> FAC-Neutral Test (D5)	
<input type="checkbox"/> Surface Soil Cracks (B6)	<input type="checkbox"/> Stunted or Stresses Plants (D1) (LRR A)	<input type="checkbox"/> Raised Ant Mounds (D6) (LRR A)	
<input type="checkbox"/> Inundation Visible on Aerial Imagery (B7)	<input type="checkbox"/> Other (Explain in Remarks)	<input type="checkbox"/> Frost-Heave Hummocks (D7)	
<input type="checkbox"/> Sparsely Vegetated Concave Surface (B8)			

Field Observations: Surface Water Present? Yes <input type="checkbox"/> No <input checked="" type="checkbox"/> Depth (inches): _____ Water Table Present? Yes <input type="checkbox"/> No <input checked="" type="checkbox"/> Depth (inches): _____ Saturation Present? (includes capillary fringe) Yes <input type="checkbox"/> No <input checked="" type="checkbox"/> Depth (inches): _____		Wetland Hydrology Present? Yes <input type="checkbox"/> No <input checked="" type="checkbox"/>	
--	--	---	--

Describe Recorded Data (stream gauge, monitoring well, aerial photos, previous inspections), if available:

Remarks: No saturation or water table observed in sample plot

WETLAND DETERMINATION DATA FORM – Western Mountains, Valleys, and Coast Region

Project Site: Sound Transit East Link Extension Project City/County: Bellevue/King Sampling Date: Feb. 14, 2013
 Applicant/Owner: Sound Transit State: WA Sampling Point: BNSF East SPW
 Investigator(s): C Douglas & J. Pursley Section, Township, Range: S29, T24N, R5E
 Landform (hillslope, terrace, etc.): Narrow area between development Local relief (concave, convex, none): concave Slope (%): 0% to 2%
 Subregion (LRR): A Lat: 47.62N Long: 122.18W Datum: _____
 Soil Map Unit Name: Kitsap silt loam NWI classification: None Mapped
 Are climatic / hydrologic conditions on the site typical for this time of year? Yes No (If no, explain in Remarks.)
 Are Vegetation , Soil , or Hydrology , significantly disturbed? Are "Normal Circumstances" present? Yes No
 Are Vegetation , Soil , or Hydrology , naturally problematic? (If needed, explain any answers in Remarks.)

SUMMARY OF FINDINGS – Attach site map showing sampling point locations, transects, important features, etc.

Hydrophytic Vegetation Present?	Yes <input checked="" type="checkbox"/>	No <input type="checkbox"/>	Is the Sampled Area within a Wetland?	Yes <input checked="" type="checkbox"/>	No <input type="checkbox"/>
Hydric Soil Present?	Yes <input checked="" type="checkbox"/>	No <input type="checkbox"/>		Yes <input checked="" type="checkbox"/>	No <input type="checkbox"/>
Wetland Hydrology Present?	Yes <input checked="" type="checkbox"/>	No <input type="checkbox"/>		Yes <input checked="" type="checkbox"/>	No <input type="checkbox"/>
Remarks: Wetland BNSF East is located in narrow area between railroad tracks and development. Wetland is a narrow depression with culverts at both ends. Wetland includes depressional HGM class.					

VEGETATION – Use scientific names of plants

Tree Stratum (Plot size: 30 foot radius)	Absolute % Cover	Dominant Species?	Indicator Status	Dominance Test Worksheet:																
1. _____	_____	_____	_____	Number of Dominant Species That Are OBL, FACW, or FAC: <u>3</u> (A) Total Number of Dominant Species Across All Strata: <u>3</u> (B) Percent of Dominant Species That Are OBL, FACW, or FAC: <u>100</u> (A/B)																
2. _____	_____	_____	_____																	
3. _____	_____	_____	_____																	
4. _____	_____	_____	_____																	
50% = <u>0</u> , 20% = <u>0</u>	<u>0</u>	= Total Cover		Prevalence Index worksheet: <table style="width: 100%; border: none;"> <tr> <td style="text-align: center;">Total % Cover of:</td> <td style="text-align: center;">Multiply by:</td> </tr> <tr> <td>OBL species _____</td> <td>x1 = _____</td> </tr> <tr> <td>FACW species _____</td> <td>x2 = _____</td> </tr> <tr> <td>FAC species _____</td> <td>x3 = _____</td> </tr> <tr> <td>FACU species _____</td> <td>x4 = _____</td> </tr> <tr> <td>UPL species _____</td> <td>x5 = _____</td> </tr> <tr> <td>Column Totals: _____ (A)</td> <td>_____ (B)</td> </tr> <tr> <td colspan="2" style="text-align: center;">Prevalence Index = B/A = _____</td> </tr> </table>	Total % Cover of:	Multiply by:	OBL species _____	x1 = _____	FACW species _____	x2 = _____	FAC species _____	x3 = _____	FACU species _____	x4 = _____	UPL species _____	x5 = _____	Column Totals: _____ (A)	_____ (B)	Prevalence Index = B/A = _____	
Total % Cover of:	Multiply by:																			
OBL species _____	x1 = _____																			
FACW species _____	x2 = _____																			
FAC species _____	x3 = _____																			
FACU species _____	x4 = _____																			
UPL species _____	x5 = _____																			
Column Totals: _____ (A)	_____ (B)																			
Prevalence Index = B/A = _____																				
Sapling/Shrub Stratum (Plot size: 15 foot radius)																				
1. _____	_____	_____	_____																	
2. _____	_____	_____	_____																	
3. _____	_____	_____	_____																	
4. _____	_____	_____	_____																	
5. _____	_____	_____	_____																	
50% = <u>0</u> , 20% = <u>0</u>	<u>0</u>	= Total Cover																		
Herb Stratum (Plot size: 3 foot radius)																				
1. <u>Juncus effusus</u>	<u>15</u>	<u>no</u>	<u>FACW</u>																	
2. <u>Lemna minor</u>	<u>30</u>	<u>yes</u>	<u>OBL</u>																	
3. <u>Phalaris arundinacea</u>	<u>50</u>	<u>yes</u>	<u>FACW</u>																	
4. <u>Typha latifolia</u>	<u>40</u>	<u>yes</u>	<u>OBL</u>																	
5. _____	_____	_____	_____																	
6. _____	_____	_____	_____																	
7. _____	_____	_____	_____																	
8. _____	_____	_____	_____																	
9. _____	_____	_____	_____																	
10. _____	_____	_____	_____																	
11. _____	_____	_____	_____																	
50% = <u>0</u> , 20% = <u>3</u>	<u>100</u>	= Total Cover																		
Woody Vine Stratum (Plot size: 3 foot radius)																				
1. _____	_____	_____	_____																	
2. _____	_____	_____	_____																	
50% = _____, 20% = _____	<u>0</u>	= Total Cover																		
% Bare Ground in Herb Stratum <u>0</u>																				
Hydrophytic Vegetation Indicators: <input type="checkbox"/> 1 – Rapid Test for Hydrophytic Vegetation <input checked="" type="checkbox"/> 2 - Dominance Test is >50% <input type="checkbox"/> 3 - Prevalence Index is $\leq 3.0^1$ <input type="checkbox"/> 4 - Morphological Adaptations ¹ (Provide supporting data in Remarks or on a separate sheet) <input type="checkbox"/> 5 - Wetland Non-Vascular Plants ¹ <input type="checkbox"/> Problematic Hydrophytic Vegetation ¹ (Explain)																				
¹ Indicators of hydric soil and wetland hydrology must be present, unless disturbed or problematic.																				
Hydrophytic Vegetation Present? Yes <input checked="" type="checkbox"/> No <input type="checkbox"/>																				

Remarks: 100% dominant wetland vegetation per the Dominance Test

SOIL

Profile Description: (Describe to the depth needed to document the indicator or confirm the absence of indicators.)

Depth (inches)	Matrix		Redox Features				Texture	Remarks
	Color (moist)	%	Color (moist)	%	Type ¹	Loc ²		
0 to 1	Duff	100	None	None	None	None	Duff	w/leaf litter
1 to 18+	10YR 5/1	100	None	None	None	None	Silt loam	
_____	_____	_____	_____	_____	_____	_____	_____	_____
_____	_____	_____	_____	_____	_____	_____	_____	_____
_____	_____	_____	_____	_____	_____	_____	_____	_____
_____	_____	_____	_____	_____	_____	_____	_____	_____
_____	_____	_____	_____	_____	_____	_____	_____	_____

¹Type: C= Concentration, D=Depletion, RM=Reduced Matrix, CS=Covered or Coated Sand Grains. ²Location: PL=Pore Lining, M=Matrix

Hydric Soil Indicators: (Applicable to all LRRs, unless otherwise noted.)

- Histosol (A1)
- Histic Epipedon (A2)
- Black Histic (A3)
- Hydrogen Sulfide (A4)
- Depleted Below Dark Surface (A11)
- Thick Dark Surface (A12)
- Sandy Mucky Mineral (S1)
- Sandy Gleyed Matrix (S4)
- Sandy Redox (S5)
- Stripped Matrix (S6)
- Loamy Mucky Mineral (F1) **(except MLRA 1)**
- Loamy Gleyed Matrix (F2)
- Depleted Matrix (F3)
- Redox Dark Surface (F6)
- Depleted Dark Surface (F7)
- Redox Depressions (F8)

Indicators for Problematic Hydric Soils³:

- 2 cm Muck (A10)
- Red Parent Material (TF2)
- Very Shallow Dark Surface (TF12)
- Other (Explain in Remarks)

³Indicators of hydrophytic vegetation and wetland hydrology must be present, unless disturbed or problematic.

Restrictive Layer (if present):

Type: _____
 Depth (inches): _____

Hydric Soils Present? Yes No

Remarks: 1 chroma

HYDROLOGY

Wetland Hydrology Indicators:

Primary Indicators (minimum of one required; check all that apply)

- Surface Water (A1)
- High Water Table (A2)
- Saturation (A3)
- Water Marks (B1)
- Sediment Deposits (B2)
- Drift Deposits (B3)
- Algal Mat or Crust (B4)
- Iron Deposits (B5)
- Surface Soil Cracks (B6)
- Inundation Visible on Aerial Imagery (B7)
- Sparsely Vegetated Concave Surface (B8)
- Water-Stained Leaves (B9) **(except MLRA 1, 2, 4A, and 4B)**
- Salt Crust (B11)
- Aquatic Invertebrates (B13)
- Hydrogen Sulfide Odor (C1)
- Oxidized Rhizospheres along Living Roots (C3)
- Presence of Reduced Iron (C4)
- Recent Iron Reduction in Tilled Soils (C6)
- Stunted or Stresses Plants (D1) **(LRR A)**
- Other (Explain in Remarks)

Secondary Indicators (2 or more required)

- Water-Stained Leaves (B9) **(MLRA 1, 2, 4A, and 4B)**
- Drainage Patterns (B10)
- Dry-Season Water Table (C2)
- Saturation Visible on Aerial Imagery (C9)
- Geomorphic Position (D2)
- Shallow Aquitard (D3)
- FAC-Neutral Test (D5)
- Raised Ant Mounds (D6) **(LRR A)**
- Frost-Heave Hummocks (D7)

Field Observations:

Surface Water Present? Yes No Depth (inches): 5 inches
 Water Table Present? Yes No Depth (inches): Surface
 Saturation Present? (includes capillary fringe) Yes No Depth (inches): Surface

Wetland Hydrology Present? Yes No

Describe Recorded Data (stream gauge, monitoring well, aerial photos, previous inspections), if available:

Remarks: Surface water 5 inches deep in wetland

WETLAND DETERMINATION DATA FORM – Western Mountains, Valleys, and Coast Region

Project Site: Sound Transit East Link Extension Project City/County: Bellevue/King Sampling Date: May 15, 2013
 Applicant/Owner: Sound Transit State: WA Sampling Point: BNSF North SPU
 Investigator(s): C Douglas & J. Pursley Section, Township, Range: S29, T24N, R5E
 Landform (hillslope, terrace, etc.): Narrow area between development Local relief (concave, convex, none): concave Slope (%): 0% to 2%
 Subregion (LRR): A Lat: 47.62N Long: 122.18W Datum: _____
 Soil Map Unit Name: Kitsap silt loam NWI classification: None Mapped
 Are climatic / hydrologic conditions on the site typical for this time of year? Yes No (If no, explain in Remarks.)
 Are Vegetation , Soil , or Hydrology , significantly disturbed? Are "Normal Circumstances" present? Yes No
 Are Vegetation , Soil , or Hydrology , naturally problematic? (If needed, explain any answers in Remarks.)

SUMMARY OF FINDINGS – Attach site map showing sampling point locations, transects, important features, etc.

Hydrophytic Vegetation Present?	Yes <input checked="" type="checkbox"/>	No <input type="checkbox"/>	Is the Sampled Area within a Wetland?	Yes <input type="checkbox"/>	No <input checked="" type="checkbox"/>
Hydric Soil Present?	Yes <input type="checkbox"/>	No <input checked="" type="checkbox"/>		Yes <input type="checkbox"/>	No <input checked="" type="checkbox"/>
Wetland Hydrology Present?	Yes <input type="checkbox"/>	No <input checked="" type="checkbox"/>		Yes <input type="checkbox"/>	No <input checked="" type="checkbox"/>
Remarks: Wetland BNSF North is located in narrow area between railroad tracks with development located outside the railroad tracks. Wetland is a narrow depression with culverts at both ends that are connected to other wetlands in the area. Wetland includes depressional HGM class. The majority of the wetland included standing water at the time of the investigation. Wetland BNSF North is connected to Wetland BNSF Northeast to the south via a culvert.					

VEGETATION – Use scientific names of plants

Tree Stratum (Plot size: 30 foot radius)	Absolute % Cover	Dominant Species?	Indicator Status	Dominance Test Worksheet:																
1. <u><i>Arbutus menziesii</i></u>	<u>5</u>	<u>no</u>	<u>UPL</u>	Number of Dominant Species That Are OBL, FACW, or FAC: <u>3</u> (A) Total Number of Dominant Species Across All Strata: <u>4</u> (B) Percent of Dominant Species That Are OBL, FACW, or FAC: <u>75</u> (A/B)																
2. <u><i>Populus trichocarpa</i></u>	<u>15</u>	<u>yes</u>	<u>FAC</u>																	
3. _____	_____	_____	_____																	
4. _____	_____	_____	_____																	
50% = <u>1</u> , 20% = <u>0</u>	<u>20</u>	= Total Cover		Prevalence Index worksheet: <table style="width: 100%; border: none;"> <tr> <td style="text-align: right;">Total % Cover of:</td> <td style="text-align: left;">Multiply by:</td> </tr> <tr> <td>OBL species _____</td> <td>x1 = _____</td> </tr> <tr> <td>FACW species _____</td> <td>x2 = _____</td> </tr> <tr> <td>FAC species _____</td> <td>x3 = _____</td> </tr> <tr> <td>FACU species _____</td> <td>x4 = _____</td> </tr> <tr> <td>UPL species _____</td> <td>x5 = _____</td> </tr> <tr> <td>Column Totals: _____ (A)</td> <td>_____ (B)</td> </tr> <tr> <td colspan="2" style="text-align: center;">Prevalence Index = B/A = _____</td> </tr> </table>	Total % Cover of:	Multiply by:	OBL species _____	x1 = _____	FACW species _____	x2 = _____	FAC species _____	x3 = _____	FACU species _____	x4 = _____	UPL species _____	x5 = _____	Column Totals: _____ (A)	_____ (B)	Prevalence Index = B/A = _____	
Total % Cover of:	Multiply by:																			
OBL species _____	x1 = _____																			
FACW species _____	x2 = _____																			
FAC species _____	x3 = _____																			
FACU species _____	x4 = _____																			
UPL species _____	x5 = _____																			
Column Totals: _____ (A)	_____ (B)																			
Prevalence Index = B/A = _____																				
Sapling/Shrub Stratum (Plot size: 15 foot radius)																				
1. <u><i>Rubus armeniacus</i></u>	<u>50</u>	<u>yes</u>	<u>FACU</u>																	
2. _____	_____	_____	_____																	
3. _____	_____	_____	_____																	
4. _____	_____	_____	_____																	
5. _____	_____	_____	_____																	
50% = <u>1</u> , 20% = <u>0</u>	<u>50</u>	= Total Cover																		
Herb Stratum (Plot size: 3 foot radius)																				
1. <u><i>Agrostis capillaris</i></u>	<u>10</u>	<u>yes</u>	<u>FAC</u>	Hydrophytic Vegetation Indicators: <input type="checkbox"/> 1 – Rapid Test for Hydrophytic Vegetation <input checked="" type="checkbox"/> 2 - Dominance Test is >50% <input type="checkbox"/> 3 - Prevalence Index is $\leq 3.0^1$ <input type="checkbox"/> 4 - Morphological Adaptations ¹ (Provide supporting data in Remarks or on a separate sheet) <input type="checkbox"/> 5 - Wetland Non-Vascular Plants ¹ <input type="checkbox"/> Problematic Hydrophytic Vegetation ¹ (Explain) ¹ Indicators of hydric soil and wetland hydrology must be present, unless disturbed or problematic.																
2. <u><i>Phalaris arundinacea</i></u>	<u>5</u>	<u>yes</u>	<u>FACW</u>																	
3. _____	_____	_____	_____																	
4. _____	_____	_____	_____																	
5. _____	_____	_____	_____																	
6. _____	_____	_____	_____																	
7. _____	_____	_____	_____																	
8. _____	_____	_____	_____																	
9. _____	_____	_____	_____																	
10. _____	_____	_____	_____																	
11. _____	_____	_____	_____																	
50% = <u>1</u> , 20% = <u>1</u>	<u>15</u>	= Total Cover																		
Woody Vine Stratum (Plot size: 3 foot radius)																				
1. _____	_____	_____	_____	Hydrophytic Vegetation Present? Yes <input checked="" type="checkbox"/> No <input type="checkbox"/>																
2. _____	_____	_____	_____																	
50% = _____, 20% = _____	<u>0</u>	= Total Cover																		
% Bare Ground in Herb Stratum <u>85</u>																				

Remarks: 75% dominant wetland vegetation per the Dominance Test. 100% Himalayan blackberry in shrub cover.

SOIL

Profile Description: (Describe to the depth needed to document the indicator or confirm the absence of indicators.)								
Depth (inches)	Matrix		Redox Features				Texture	Remarks
	Color (moist)	%	Color (moist)	%	Type ¹	Loc ²		
0 to 4	Fill	100	None	None	None	None	Gravel	& angular rock
4 to 18+	10YR 3/4	100	None	None	None	None	Silt	w/fill gravel
_____	_____	_____	_____	_____	_____	_____	_____	_____
_____	_____	_____	_____	_____	_____	_____	_____	_____
_____	_____	_____	_____	_____	_____	_____	_____	_____
_____	_____	_____	_____	_____	_____	_____	_____	_____
_____	_____	_____	_____	_____	_____	_____	_____	_____
¹ Type: C= Concentration, D=Depletion, RM=Reduced Matrix, CS=Covered or Coated Sand Grains.					² Location: PL=Pore Lining, M=Matrix			
Hydric Soil Indicators: (Applicable to all LRRs, unless otherwise noted.)						Indicators for Problematic Hydric Soils³:		
<input type="checkbox"/> Histosol (A1)			<input type="checkbox"/> Sandy Redox (S5)			<input type="checkbox"/> 2 cm Muck (A10)		
<input type="checkbox"/> Histic Epipedon (A2)			<input type="checkbox"/> Stripped Matrix (S6)			<input type="checkbox"/> Red Parent Material (TF2)		
<input type="checkbox"/> Black Histic (A3)			<input type="checkbox"/> Loamy Mucky Mineral (F1) (except MLRA 1)			<input type="checkbox"/> Very Shallow Dark Surface (TF12)		
<input type="checkbox"/> Hydrogen Sulfide (A4)			<input type="checkbox"/> Loamy Gleyed Matrix (F2)			<input type="checkbox"/> Other (Explain in Remarks)		
<input type="checkbox"/> Depleted Below Dark Surface (A11)			<input type="checkbox"/> Depleted Matrix (F3)			³ Indicators of hydrophytic vegetation and wetland hydrology must be present, unless disturbed or problematic.		
<input type="checkbox"/> Thick Dark Surface (A12)			<input type="checkbox"/> Redox Dark Surface (F6)					
<input type="checkbox"/> Sandy Mucky Mineral (S1)			<input type="checkbox"/> Depleted Dark Surface (F7)					
<input type="checkbox"/> Sandy Gleyed Matrix (S4)			<input type="checkbox"/> Redox Depressions (F8)					
Restrictive Layer (if present):								
Type: <u>Fill prism</u>						Yes <input type="checkbox"/> No <input checked="" type="checkbox"/>		
Depth (inches): <u>4 inches</u>								
Remarks: <u>4 chroma, dominated by fill, gravel & angular rock</u>								

HYDROLOGY

Wetland Hydrology Indicators:			
Primary Indicators (minimum of one required; check all that apply)		Secondary Indicators (2 or more required)	
<input type="checkbox"/> Surface Water (A1)	<input type="checkbox"/> Water-Stained Leaves (B9)	<input type="checkbox"/> Water-Stained Leaves (B9)	
<input type="checkbox"/> High Water Table (A2)	(except MLRA 1, 2, 4A, and 4B)	(MLRA 1, 2, 4A, and 4B)	
<input type="checkbox"/> Saturation (A3)	<input type="checkbox"/> Salt Crust (B11)	<input type="checkbox"/> Drainage Patterns (B10)	
<input type="checkbox"/> Water Marks (B1)	<input type="checkbox"/> Aquatic Invertebrates (B13)	<input type="checkbox"/> Dry-Season Water Table (C2)	
<input type="checkbox"/> Sediment Deposits (B2)	<input type="checkbox"/> Hydrogen Sulfide Odor (C1)	<input type="checkbox"/> Saturation Visible on Aerial Imagery (C9)	
<input type="checkbox"/> Drift Deposits (B3)	<input type="checkbox"/> Oxidized Rhizospheres along Living Roots (C3)	<input type="checkbox"/> Geomorphic Position (D2)	
<input type="checkbox"/> Algal Mat or Crust (B4)	<input type="checkbox"/> Presence of Reduced Iron (C4)	<input type="checkbox"/> Shallow Aquitard (D3)	
<input type="checkbox"/> Iron Deposits (B5)	<input type="checkbox"/> Recent Iron Reduction in Tilled Soils (C6)	<input type="checkbox"/> FAC-Neutral Test (D5)	
<input type="checkbox"/> Surface Soil Cracks (B6)	<input type="checkbox"/> Stunted or Stresses Plants (D1) (LRR A)	<input type="checkbox"/> Raised Ant Mounds (D6) (LRR A)	
<input type="checkbox"/> Inundation Visible on Aerial Imagery (B7)	<input type="checkbox"/> Other (Explain in Remarks)	<input type="checkbox"/> Frost-Heave Hummocks (D7)	
<input type="checkbox"/> Sparsely Vegetated Concave Surface (B8)			
Field Observations:		Wetland Hydrology Present?	
Surface Water Present?	Yes <input type="checkbox"/> No <input checked="" type="checkbox"/>	Yes <input type="checkbox"/> No <input checked="" type="checkbox"/>	
Water Table Present?	Yes <input type="checkbox"/> No <input checked="" type="checkbox"/>		
Saturation Present? (includes capillary fringe)	Yes <input type="checkbox"/> No <input checked="" type="checkbox"/>		
Describe Recorded Data (stream gauge, monitoring well, aerial photos, previous inspections), if available:			
Remarks: <u>No saturation or water table observed in sample plot</u>			

WETLAND DETERMINATION DATA FORM – Western Mountains, Valleys, and Coast Region

Project Site: Sound Transit East Link Extension Project City/County: Bellevue/King Sampling Date: May 15, 2013
 Applicant/Owner: Sound Transit State: WA Sampling Point: BNSF North SPW
 Investigator(s): C Douglas & J. Pursley Section, Township, Range: S29, T24N, R5E
 Landform (hillslope, terrace, etc.): Narrow area between development Local relief (concave, convex, none): concave Slope (%): 0% to 2%
 Subregion (LRR): A Lat: 47.62N Long: 122.18W Datum: _____
 Soil Map Unit Name: Kitsap silt loam NWI classification: None Mapped
 Are climatic / hydrologic conditions on the site typical for this time of year? Yes No (If no, explain in Remarks.)
 Are Vegetation , Soil , or Hydrology , significantly disturbed? Are "Normal Circumstances" present? Yes No
 Are Vegetation , Soil , or Hydrology , naturally problematic? (If needed, explain any answers in Remarks.)

SUMMARY OF FINDINGS – Attach site map showing sampling point locations, transects, important features, etc.

Hydrophytic Vegetation Present?	Yes <input checked="" type="checkbox"/>	No <input type="checkbox"/>	Is the Sampled Area within a Wetland?	Yes <input checked="" type="checkbox"/>	No <input type="checkbox"/>
Hydric Soil Present?	Yes <input checked="" type="checkbox"/>	No <input type="checkbox"/>		Yes <input checked="" type="checkbox"/>	No <input type="checkbox"/>
Wetland Hydrology Present?	Yes <input checked="" type="checkbox"/>	No <input type="checkbox"/>			
Remarks: Wetland BNSF North is located in narrow area between railroad tracks with development located outside the railroad tracks. Wetland is a narrow depression with culverts at both ends that are connected to other wetlands in the area. Wetland includes depression and slope HGM classes. The majority of the wetland included standing water at the time of the investigation. Wetland BNSF North is connected to Wetland BNSF Northeast to the south via a culvert.					

VEGETATION – Use scientific names of plants

Tree Stratum (Plot size: <u>30 foot radius</u>)	Absolute % Cover	Dominant Species?	Indicator Status	Dominance Test Worksheet:																
1. <u>Populus trichocarpa</u>	<u>60</u>	<u>yes</u>	<u>FAC</u>	Number of Dominant Species That Are OBL, FACW, or FAC: <u>3</u> (A)																
2. <u>Salix lasiandra</u>	<u>15</u>	<u>yes</u>	<u>FACW</u>																	
3. _____	_____	_____	_____	Total Number of Dominant Species Across All Strata: <u>4</u> (B)																
4. _____	_____	_____	_____	Percent of Dominant Species That Are OBL, FACW, or FAC: <u>75</u> (A/B)																
50% = <u>1</u> , 20% = <u>1</u>	<u>75</u>	= Total Cover																		
Sapling/Shrub Stratum (Plot size: <u>15 foot radius</u>)	Absolute % Cover	Dominant Species?	Indicator Status	Prevalence Index worksheet:																
1. <u>Rubus armeniacus</u>	<u>15</u>	<u>yes</u>	<u>FACU</u>	<table style="width: 100%; border-collapse: collapse;"> <tr> <th style="width: 50%;">Total % Cover of:</th> <th style="width: 50%;">Multiply by:</th> </tr> <tr> <td>OBL species _____</td> <td>x1 = _____</td> </tr> <tr> <td>FACW species _____</td> <td>x2 = _____</td> </tr> <tr> <td>FAC species _____</td> <td>x3 = _____</td> </tr> <tr> <td>FACU species _____</td> <td>x4 = _____</td> </tr> <tr> <td>UPL species _____</td> <td>x5 = _____</td> </tr> <tr> <td>Column Totals: _____ (A)</td> <td>_____ (B)</td> </tr> <tr> <td colspan="2" style="text-align: center;">Prevalence Index = B/A = _____</td> </tr> </table>	Total % Cover of:	Multiply by:	OBL species _____	x1 = _____	FACW species _____	x2 = _____	FAC species _____	x3 = _____	FACU species _____	x4 = _____	UPL species _____	x5 = _____	Column Totals: _____ (A)	_____ (B)	Prevalence Index = B/A = _____	
Total % Cover of:	Multiply by:																			
OBL species _____	x1 = _____																			
FACW species _____	x2 = _____																			
FAC species _____	x3 = _____																			
FACU species _____	x4 = _____																			
UPL species _____	x5 = _____																			
Column Totals: _____ (A)	_____ (B)																			
Prevalence Index = B/A = _____																				
2. <u>Solanum dulcamara</u>	<u>45</u>	<u>yes</u>	<u>FACW</u>																	
3. <u>Spiraea douglasii</u>	<u>10</u>	<u>no</u>	<u>FACW</u>																	
4. _____	_____	_____	_____																	
5. _____	_____	_____	_____																	
50% = <u>1</u> , 20% = <u>1</u>	<u>70</u>	= Total Cover																		
Herb Stratum (Plot size: <u>3 foot radius</u>)	Absolute % Cover	Dominant Species?	Indicator Status	Hydrophytic Vegetation Indicators:																
1. _____	_____	_____	_____	<input type="checkbox"/> 1 – Rapid Test for Hydrophytic Vegetation <input checked="" type="checkbox"/> 2 - Dominance Test is >50% <input type="checkbox"/> 3 - Prevalence Index is ≤3.0 ¹ <input type="checkbox"/> 4 - Morphological Adaptations ¹ (Provide supporting data in Remarks or on a separate sheet) <input type="checkbox"/> 5 - Wetland Non-Vascular Plants ¹ <input type="checkbox"/> Problematic Hydrophytic Vegetation ¹ (Explain)																
2. _____	_____	_____	_____																	
3. _____	_____	_____	_____																	
4. _____	_____	_____	_____																	
5. _____	_____	_____	_____																	
6. _____	_____	_____	_____																	
7. _____	_____	_____	_____																	
8. _____	_____	_____	_____																	
9. _____	_____	_____	_____																	
10. _____	_____	_____	_____																	
11. _____	_____	_____	_____																	
50% = <u>0</u> , 20% = <u>0</u>	<u>0</u>	= Total Cover		¹ Indicators of hydric soil and wetland hydrology must be present, unless disturbed or problematic.																
Woody Vine Stratum (Plot size: <u>3 foot radius</u>)	Absolute % Cover	Dominant Species?	Indicator Status	Hydrophytic Vegetation Present?																
1. _____	_____	_____	_____	Yes <input checked="" type="checkbox"/> No <input type="checkbox"/>																
2. _____	_____	_____	_____																	
50% = _____, 20% = _____	<u>0</u>	= Total Cover																		
% Bare Ground in Herb Stratum <u>100</u>																				

Remarks: 75% dominant wetland vegetation per the Dominance Test

SOIL

Profile Description: (Describe to the depth needed to document the indicator or confirm the absence of indicators.)

Depth (inches)	Matrix		Redox Features				Texture	Remarks
	Color (moist)	%	Color (moist)	%	Type ¹	Loc ²		
<u>0 to 2</u>	<u>10YR 3/1</u>	<u>100</u>	<u>None</u>	<u>None</u>	<u>None</u>	<u>None</u>	<u>Silt loam</u>	<u>w/dense root layer</u>
<u>2 to 6</u>	<u>10YR 3/1</u>	<u>100</u>	<u>None</u>	<u>None</u>	<u>None</u>	<u>None</u>	<u>Silt loam</u>	
<u>6 to 18+</u>	<u>10YR 5/1</u>	<u>90</u>	<u>10YR 5/4</u>	<u>10</u>	<u>D</u>	<u>M</u>	<u>Silt loam</u>	<u>w/gravel</u>
_____	_____	_____	_____	_____	_____	_____	_____	_____
_____	_____	_____	_____	_____	_____	_____	_____	_____
_____	_____	_____	_____	_____	_____	_____	_____	_____
_____	_____	_____	_____	_____	_____	_____	_____	_____

¹Type: C= Concentration, D=Depletion, RM=Reduced Matrix, CS=Covered or Coated Sand Grains. ²Location: PL=Pore Lining, M=Matrix

Hydric Soil Indicators: (Applicable to all LRRs, unless otherwise noted.)

Indicators for Problematic Hydric Soils³:

- | | | |
|--|--|---|
| <input type="checkbox"/> Histosol (A1) | <input type="checkbox"/> Sandy Redox (S5) | <input type="checkbox"/> 2 cm Muck (A10) |
| <input type="checkbox"/> Histic Epipedon (A2) | <input type="checkbox"/> Stripped Matrix (S6) | <input type="checkbox"/> Red Parent Material (TF2) |
| <input type="checkbox"/> Black Histic (A3) | <input type="checkbox"/> Loamy Mucky Mineral (F1) (except MLRA 1) | <input type="checkbox"/> Very Shallow Dark Surface (TF12) |
| <input type="checkbox"/> Hydrogen Sulfide (A4) | <input type="checkbox"/> Loamy Gleyed Matrix (F2) | <input type="checkbox"/> Other (Explain in Remarks) |
| <input type="checkbox"/> Depleted Below Dark Surface (A11) | <input checked="" type="checkbox"/> Depleted Matrix (F3) | |
| <input checked="" type="checkbox"/> Thick Dark Surface (A12) | <input type="checkbox"/> Redox Dark Surface (F6) | |
| <input type="checkbox"/> Sandy Mucky Mineral (S1) | <input type="checkbox"/> Depleted Dark Surface (F7) | |
| <input type="checkbox"/> Sandy Gleyed Matrix (S4) | <input type="checkbox"/> Redox Depressions (F8) | |

³Indicators of hydrophytic vegetation and wetland hydrology must be present, unless disturbed or problematic.

Restrictive Layer (if present):

Type: _____
 Depth (inches): _____

Hydric Soils Present? Yes No

Remarks: 1 chroma with redox features

HYDROLOGY

Wetland Hydrology Indicators:

Primary Indicators (minimum of one required; check all that apply)

Secondary Indicators (2 or more required)

- | | | |
|--|---|--|
| <input type="checkbox"/> Surface Water (A1) | <input checked="" type="checkbox"/> Water-Stained Leaves (B9) | <input type="checkbox"/> Water-Stained Leaves (B9) |
| <input checked="" type="checkbox"/> High Water Table (A2) | (except MLRA 1, 2, 4A, and 4B) | (MLRA 1, 2, 4A, and 4B) |
| <input checked="" type="checkbox"/> Saturation (A3) | <input type="checkbox"/> Salt Crust (B11) | <input type="checkbox"/> Drainage Patterns (B10) |
| <input checked="" type="checkbox"/> Water Marks (B1) | <input type="checkbox"/> Aquatic Invertebrates (B13) | <input type="checkbox"/> Dry-Season Water Table (C2) |
| <input type="checkbox"/> Sediment Deposits (B2) | <input type="checkbox"/> Hydrogen Sulfide Odor (C1) | <input type="checkbox"/> Saturation Visible on Aerial Imagery (C9) |
| <input type="checkbox"/> Drift Deposits (B3) | <input type="checkbox"/> Oxidized Rhizospheres along Living Roots (C3) | <input type="checkbox"/> Geomorphic Position (D2) |
| <input type="checkbox"/> Algal Mat or Crust (B4) | <input type="checkbox"/> Presence of Reduced Iron (C4) | <input type="checkbox"/> Shallow Aquitard (D3) |
| <input type="checkbox"/> Iron Deposits (B5) | <input type="checkbox"/> Recent Iron Reduction in Tilled Soils (C6) | <input type="checkbox"/> FAC-Neutral Test (D5) |
| <input type="checkbox"/> Surface Soil Cracks (B6) | <input type="checkbox"/> Stunted or Stresses Plants (D1) (LRR A) | <input type="checkbox"/> Raised Ant Mounds (D6) (LRR A) |
| <input type="checkbox"/> Inundation Visible on Aerial Imagery (B7) | <input type="checkbox"/> Other (Explain in Remarks) | <input type="checkbox"/> Frost-Heave Hummocks (D7) |
| <input type="checkbox"/> Sparsely Vegetated Concave Surface (B8) | | |

Field Observations:

Surface Water Present? Yes No Depth (inches): 1 inch
 Water Table Present? Yes No Depth (inches): Surface
 Saturation Present? (includes capillary fringe) Yes No Depth (inches): Surface

Wetland Hydrology Present? Yes No

Describe Recorded Data (stream gauge, monitoring well, aerial photos, previous inspections), if available:

Remarks: Surface water 1 inch deep at sample plot location, majority of the wetland included standing water at the time of the investigation.

WETLAND DETERMINATION DATA FORM – Western Mountains, Valleys, and Coast Region

Project Site: Sound Transit East Link Extension Project City/County: Bellevue/King Sampling Date: May 15, 2013
 Applicant/Owner: Sound Transit State: WA Sampling Point: BNSF Northeast SPU
 Investigator(s): C Douglas & J. Pursley Section, Township, Range: S29, T24N, R5E
 Landform (hillslope, terrace, etc.): Narrow area between development Local relief (concave, convex, none): concave Slope (%): 0% to 2%
 Subregion (LRR): A Lat: 47.62N Long: 122.18W Datum: _____
 Soil Map Unit Name: Kitsap silt loam NWI classification: None Mapped
 Are climatic / hydrologic conditions on the site typical for this time of year? Yes No (If no, explain in Remarks.)
 Are Vegetation , Soil , or Hydrology , significantly disturbed? Are "Normal Circumstances" present? Yes No
 Are Vegetation , Soil , or Hydrology , naturally problematic? (If needed, explain any answers in Remarks.)

SUMMARY OF FINDINGS – Attach site map showing sampling point locations, transects, important features, etc.

Hydrophytic Vegetation Present?	Yes <input checked="" type="checkbox"/>	No <input type="checkbox"/>	Is the Sampled Area within a Wetland?	Yes <input type="checkbox"/>	No <input checked="" type="checkbox"/>
Hydric Soil Present?	Yes <input type="checkbox"/>	No <input checked="" type="checkbox"/>		Yes <input type="checkbox"/>	No <input checked="" type="checkbox"/>
Wetland Hydrology Present?	Yes <input type="checkbox"/>	No <input checked="" type="checkbox"/>		Yes <input type="checkbox"/>	No <input checked="" type="checkbox"/>
Remarks: Wetland BNSF Northeast is located in narrow area between railroad tracks with development located outside the railroad tracks. Wetland is a narrow depression with culverts at both ends that are connected to other wetlands in the area. Wetland includes depressional HGM class. The majority of the wetland included standing water at the time of the investigation. Wetland BNSF Northeast is connected to Wetland BNSF Northwest to the north via a culvert.					

VEGETATION – Use scientific names of plants

Tree Stratum (Plot size: 30 foot radius)	Absolute % Cover	Dominant Species?	Indicator Status	Dominance Test Worksheet:	
1. <u>Populus trichocarpa</u>	<u>90</u>	<u>yes</u>	<u>FAC</u>	Number of Dominant Species That Are OBL, FACW, or FAC: <u>2</u> (A) Total Number of Dominant Species Across All Strata: <u>3</u> (B) Percent of Dominant Species That Are OBL, FACW, or FAC: <u>67</u> (A/B)	
2. _____	_____	_____	_____		
3. _____	_____	_____	_____		
4. _____	_____	_____	_____		
50% = <u>1</u> , 20% = <u>0</u>	<u>90</u>	= Total Cover			
Shrub/Stratum (Plot size: 15 foot radius)	Absolute % Cover	Dominant Species?	Indicator Status	Prevalence Index worksheet:	
1. <u>Rubus armeniacus</u>	<u>100</u>	<u>yes</u>	<u>FACU</u>	Total % Cover of: OBL species _____ x1 = _____ FACW species _____ x2 = _____ FAC species _____ x3 = _____ FACU species _____ x4 = _____ UPL species _____ x5 = _____ Column Totals: _____ (A) _____ (B) Prevalence Index = B/A = _____	
2. _____	_____	_____	_____		
3. _____	_____	_____	_____		
4. _____	_____	_____	_____		
5. _____	_____	_____	_____		
50% = <u>1</u> , 20% = <u>0</u>	<u>100</u>	= Total Cover			
Herb Stratum (Plot size: 3 foot radius)	Absolute % Cover	Dominant Species?	Indicator Status		Hydrophytic Vegetation Indicators:
1. <u>Equisetum arvense</u>	<u>1</u>	<u>yes</u>	<u>FAC</u>		<input type="checkbox"/> 1 – Rapid Test for Hydrophytic Vegetation <input checked="" type="checkbox"/> 2 - Dominance Test is >50% <input type="checkbox"/> 3 - Prevalence Index is ≤3.0 ¹ <input type="checkbox"/> 4 - Morphological Adaptations ¹ (Provide supporting data in Remarks or on a separate sheet) <input type="checkbox"/> 5 - Wetland Non-Vascular Plants ¹ <input type="checkbox"/> Problematic Hydrophytic Vegetation ¹ (Explain) ¹ Indicators of hydric soil and wetland hydrology must be present, unless disturbed or problematic.
2. _____	_____	_____	_____		
3. _____	_____	_____	_____		
4. _____	_____	_____	_____		
5. _____	_____	_____	_____		
6. _____	_____	_____	_____		
7. _____	_____	_____	_____		
8. _____	_____	_____	_____		
9. _____	_____	_____	_____		
10. _____	_____	_____	_____		
11. _____	_____	_____	_____		
50% = <u>1</u> , 20% = <u>0</u>	<u>1</u>	= Total Cover			
Woody Vine Stratum (Plot size: 3 foot radius)	Absolute % Cover	Dominant Species?	Indicator Status	Hydrophytic Vegetation Present?	
1. _____	_____	_____	_____	Yes <input checked="" type="checkbox"/> No <input type="checkbox"/>	
2. _____	_____	_____	_____		
50% = _____, 20% = _____	<u>0</u>	= Total Cover			
% Bare Ground in Herb Stratum <u>99</u>					

Remarks: 67% dominant wetland vegetation per the Dominance Test. 100% Himalayan blackberry in shrub cover.

SOIL

Profile Description: (Describe to the depth needed to document the indicator or confirm the absence of indicators.)								
Depth (inches)	Matrix		Redox Features				Texture	Remarks
	Color (moist)	%	Color (moist)	%	Type ¹	Loc ²		
0 to 18+	10YR 3/3	98	10YR 5/3	2	D	M	Clay loam	w/gravel
¹ Type: C= Concentration, D=Depletion, RM=Reduced Matrix, CS=Covered or Coated Sand Grains. ² Location: PL=Pore Lining, M=Matrix								
Hydric Soil Indicators: (Applicable to all LRRs, unless otherwise noted.)						Indicators for Problematic Hydric Soils³:		
<input type="checkbox"/> Histosol (A1)						<input type="checkbox"/> 2 cm Muck (A10)		
<input type="checkbox"/> Histic Epipedon (A2)						<input type="checkbox"/> Red Parent Material (TF2)		
<input type="checkbox"/> Black Histic (A3)						<input type="checkbox"/> Very Shallow Dark Surface (TF12)		
<input type="checkbox"/> Hydrogen Sulfide (A4)						<input type="checkbox"/> Other (Explain in Remarks)		
<input type="checkbox"/> Depleted Below Dark Surface (A11)						³ Indicators of hydrophytic vegetation and wetland hydrology must be present, unless disturbed or problematic.		
<input type="checkbox"/> Thick Dark Surface (A12)								
<input type="checkbox"/> Sandy Mucky Mineral (S1)								
<input type="checkbox"/> Sandy Gleyed Matrix (S4)								
<input type="checkbox"/> Sandy Redox (S5)								
<input type="checkbox"/> Stripped Matrix (S6)								
<input type="checkbox"/> Loamy Mucky Mineral (F1) (except MLRA 1)								
<input type="checkbox"/> Loamy Gleyed Matrix (F2)								
<input type="checkbox"/> Depleted Matrix (F3)								
<input type="checkbox"/> Redox Dark Surface (F6)								
<input type="checkbox"/> Depleted Dark Surface (F7)								
<input type="checkbox"/> Redox Depressions (F8)								
Restrictive Layer (if present):								
Type: _____								
Depth (inches): _____								
Remarks: 3 chroma with 2% redox features					Hydric Soils Present? Yes <input type="checkbox"/> No <input checked="" type="checkbox"/>			

HYDROLOGY

Wetland Hydrology Indicators:			
Primary Indicators (minimum of one required; check all that apply)		Secondary Indicators (2 or more required)	
<input type="checkbox"/> Surface Water (A1)	<input type="checkbox"/> Water-Stained Leaves (B9)	<input type="checkbox"/> Water-Stained Leaves (B9)	
<input type="checkbox"/> High Water Table (A2)	(except MLRA 1, 2, 4A, and 4B)	(MLRA 1, 2, 4A, and 4B)	
<input type="checkbox"/> Saturation (A3)	<input type="checkbox"/> Salt Crust (B11)	<input type="checkbox"/> Drainage Patterns (B10)	
<input type="checkbox"/> Water Marks (B1)	<input type="checkbox"/> Aquatic Invertebrates (B13)	<input type="checkbox"/> Dry-Season Water Table (C2)	
<input type="checkbox"/> Sediment Deposits (B2)	<input type="checkbox"/> Hydrogen Sulfide Odor (C1)	<input type="checkbox"/> Saturation Visible on Aerial Imagery (C9)	
<input type="checkbox"/> Drift Deposits (B3)	<input type="checkbox"/> Oxidized Rhizospheres along Living Roots (C3)	<input type="checkbox"/> Geomorphic Position (D2)	
<input type="checkbox"/> Algal Mat or Crust (B4)	<input type="checkbox"/> Presence of Reduced Iron (C4)	<input type="checkbox"/> Shallow Aquitard (D3)	
<input type="checkbox"/> Iron Deposits (B5)	<input type="checkbox"/> Recent Iron Reduction in Tilled Soils (C6)	<input type="checkbox"/> FAC-Neutral Test (D5)	
<input type="checkbox"/> Surface Soil Cracks (B6)	<input type="checkbox"/> Stunted or Stresses Plants (D1) (LRR A)	<input type="checkbox"/> Raised Ant Mounds (D6) (LRR A)	
<input type="checkbox"/> Inundation Visible on Aerial Imagery (B7)	<input type="checkbox"/> Other (Explain in Remarks)	<input type="checkbox"/> Frost-Heave Hummocks (D7)	
<input type="checkbox"/> Sparsely Vegetated Concave Surface (B8)			
Field Observations:			
Surface Water Present?	Yes <input type="checkbox"/> No <input checked="" type="checkbox"/>	Depth (inches):	_____
Water Table Present?	Yes <input type="checkbox"/> No <input checked="" type="checkbox"/>	Depth (inches):	_____
Saturation Present? (includes capillary fringe)	Yes <input type="checkbox"/> No <input checked="" type="checkbox"/>	Depth (inches):	_____
		Wetland Hydrology Present? Yes <input type="checkbox"/> No <input checked="" type="checkbox"/>	
Describe Recorded Data (stream gauge, monitoring well, aerial photos, previous inspections), if available:			
Remarks: No saturation or water table observed in sample plot			

WETLAND DETERMINATION DATA FORM – Western Mountains, Valleys, and Coast Region

Project Site: Sound Transit East Link Extension Project City/County: Bellevue/King Sampling Date: May 15, 2013
 Applicant/Owner: Sound Transit State: WA Sampling Point: BNSF Northeast SPW
 Investigator(s): C Douglas & J. Pursley Section, Township, Range: S29, T24N, R5E
 Landform (hillslope, terrace, etc.): Narrow area between development Local relief (concave, convex, none): concave Slope (%): 0% to 2%
 Subregion (LRR): A Lat: 47.62N Long: 122.18W Datum: _____
 Soil Map Unit Name: Kitsap silt loam NWI classification: None Mapped
 Are climatic / hydrologic conditions on the site typical for this time of year? Yes No (If no, explain in Remarks.)
 Are Vegetation , Soil , or Hydrology , significantly disturbed? Are "Normal Circumstances" present? Yes No
 Are Vegetation , Soil , or Hydrology , naturally problematic? (If needed, explain any answers in Remarks.)

SUMMARY OF FINDINGS – Attach site map showing sampling point locations, transects, important features, etc.

Hydrophytic Vegetation Present?	Yes <input checked="" type="checkbox"/>	No <input type="checkbox"/>	Is the Sampled Area within a Wetland?	Yes <input checked="" type="checkbox"/>	No <input type="checkbox"/>
Hydric Soil Present?	Yes <input checked="" type="checkbox"/>	No <input type="checkbox"/>		Yes <input checked="" type="checkbox"/>	No <input type="checkbox"/>
Wetland Hydrology Present?	Yes <input checked="" type="checkbox"/>	No <input type="checkbox"/>		Yes <input checked="" type="checkbox"/>	No <input type="checkbox"/>
Remarks: Wetland BNSF Northeast is located in narrow area between railroad tracks with development located outside the railroad tracks. Wetland is a narrow depression with culverts at both ends that are connected to other wetlands in the area. Wetland includes depressional HGM class. The majority of the wetland included standing water at the time of the investigation. Wetland BNSF Northeast is connected to Wetland BNSF North to the north via a culvert.					

VEGETATION – Use scientific names of plants

Tree Stratum (Plot size: 30 foot radius)	Absolute % Cover	Dominant Species?	Indicator Status	Dominance Test Worksheet:
1. <u><i>Alnus rubra</i></u>	60	yes	FAC	Number of Dominant Species That Are OBL, FACW, or FAC: <u>4</u> (A) Total Number of Dominant Species Across All Strata: <u>4</u> (B) Percent of Dominant Species That Are OBL, FACW, or FAC: <u>100</u> (A/B)
2. <u><i>Populus trichocarpa</i></u>	30	yes	FAC	
3. <u><i>Salix scouleriana</i></u>	10	no	FAC	
4. _____	_____	_____	_____	
50% = <u>1</u> , 20% = <u>1</u>	100	= Total Cover		
Sapling/Shrub Stratum (Plot size: 15 foot radius)	Absolute % Cover	Dominant Species?	Indicator Status	Prevalence Index worksheet:
1. <u><i>Crataegus douglasii</i></u>	5	no	FAC	Total % Cover of: _____ Multiply by: _____ OBL species _____ x1 = _____ FACW species _____ x2 = _____ FAC species _____ x3 = _____ FACU species _____ x4 = _____ UPL species _____ x5 = _____ Column Totals: _____ (A) _____ (B) Prevalence Index = B/A = _____
2. <u><i>Spiraea douglasii</i></u>	40	yes	FACW	
3. _____	_____	_____	_____	
4. _____	_____	_____	_____	
5. _____	_____	_____	_____	
50% = <u>1</u> , 20% = <u>0</u>	45	= Total Cover		
Herb Stratum (Plot size: 3 foot radius)	Absolute % Cover	Dominant Species?	Indicator Status	Hydrophytic Vegetation Indicators:
1. <u><i>Ludwigia palustris</i></u>	20	yes	OBL	<input type="checkbox"/> 1 – Rapid Test for Hydrophytic Vegetation <input checked="" type="checkbox"/> 2 - Dominance Test is >50% <input type="checkbox"/> 3 - Prevalence Index is $\leq 3.0^1$ <input type="checkbox"/> 4 - Morphological Adaptations ¹ (Provide supporting data in Remarks or on a separate sheet) <input type="checkbox"/> 5 - Wetland Non-Vascular Plants ¹ <input type="checkbox"/> Problematic Hydrophytic Vegetation ¹ (Explain) ¹ Indicators of hydric soil and wetland hydrology must be present, unless disturbed or problematic.
2. _____	_____	_____	_____	
3. _____	_____	_____	_____	
4. _____	_____	_____	_____	
5. _____	_____	_____	_____	
6. _____	_____	_____	_____	
7. _____	_____	_____	_____	
8. _____	_____	_____	_____	
9. _____	_____	_____	_____	
10. _____	_____	_____	_____	
11. _____	_____	_____	_____	
50% = <u>1</u> , 20% = <u>0</u>	20	= Total Cover		
Woody Vine Stratum (Plot size: 3 foot radius)	Absolute % Cover	Dominant Species?	Indicator Status	Hydrophytic Vegetation Present?
1. _____	_____	_____	_____	Yes <input checked="" type="checkbox"/> No <input type="checkbox"/>
2. _____	_____	_____	_____	
50% = _____, 20% = _____	0	= Total Cover		
% Bare Ground in Herb Stratum <u>80</u>				

Remarks: 100% dominant wetland vegetation per the Dominance Test

SOIL

Profile Description: (Describe to the depth needed to document the indicator or confirm the absence of indicators.)								
Depth (inches)	Matrix		Redox Features				Texture	Remarks
	Color (moist)	%	Color (moist)	%	Type ¹	Loc ²		
0 to 7	<u>10YR 4/1</u>	<u>100</u>	<u>None</u>	<u>None</u>	<u>None</u>	<u>None</u>	<u>Silt loam</u>	<u>w/dense root layer</u>
7 to 10	<u>10YR 4/1</u>	<u>100</u>	<u>None</u>	<u>None</u>	<u>None</u>	<u>None</u>	<u>Silt loam</u>	<u>Silt loam</u>
10 to 18+	<u>10YR 4/1</u>	<u>100</u>	<u>None</u>	<u>None</u>	<u>None</u>	<u>None</u>	<u>Loam</u>	<u>w/gravel</u>
_____	_____	_____	_____	_____	_____	_____	_____	_____
_____	_____	_____	_____	_____	_____	_____	_____	_____
_____	_____	_____	_____	_____	_____	_____	_____	_____
_____	_____	_____	_____	_____	_____	_____	_____	_____
¹ Type: C= Concentration, D=Depletion, RM=Reduced Matrix, CS=Covered or Coated Sand Grains. ² Location: PL=Pore Lining, M=Matrix								
Hydric Soil Indicators: (Applicable to all LRRs, unless otherwise noted.)						Indicators for Problematic Hydric Soils³:		
<input type="checkbox"/> Histosol (A1)			<input type="checkbox"/> Sandy Redox (S5)			<input type="checkbox"/> 2 cm Muck (A10)		
<input type="checkbox"/> Histic Epipedon (A2)			<input type="checkbox"/> Stripped Matrix (S6)			<input type="checkbox"/> Red Parent Material (TF2)		
<input type="checkbox"/> Black Histic (A3)			<input type="checkbox"/> Loamy Mucky Mineral (F1) (except MLRA 1)			<input type="checkbox"/> Very Shallow Dark Surface (TF12)		
<input type="checkbox"/> Hydrogen Sulfide (A4)			<input type="checkbox"/> Loamy Gleyed Matrix (F2)			<input type="checkbox"/> Other (Explain in Remarks)		
<input type="checkbox"/> Depleted Below Dark Surface (A11)			<input type="checkbox"/> Depleted Matrix (F3)			³ Indicators of hydrophytic vegetation and wetland hydrology must be present, unless disturbed or problematic.		
<input checked="" type="checkbox"/> Thick Dark Surface (A12)			<input type="checkbox"/> Redox Dark Surface (F6)					
<input type="checkbox"/> Sandy Mucky Mineral (S1)			<input type="checkbox"/> Depleted Dark Surface (F7)					
<input type="checkbox"/> Sandy Gleyed Matrix (S4)			<input type="checkbox"/> Redox Depressions (F8)					
Restrictive Layer (if present):					Hydric Soils Present?			
Type: _____					Yes <input checked="" type="checkbox"/> No <input type="checkbox"/>			
Depth (inches): _____								
Remarks: 1 chroma								

HYDROLOGY

Wetland Hydrology Indicators:			
Primary Indicators (minimum of one required; check all that apply)		Secondary Indicators (2 or more required)	
<input type="checkbox"/> Surface Water (A1)	<input checked="" type="checkbox"/> Water-Stained Leaves (B9)	<input type="checkbox"/> Water-Stained Leaves (B9)	
<input checked="" type="checkbox"/> High Water Table (A2)	(except MLRA 1, 2, 4A, and 4B)	(MLRA 1, 2, 4A, and 4B)	
<input checked="" type="checkbox"/> Saturation (A3)	<input type="checkbox"/> Salt Crust (B11)	<input type="checkbox"/> Drainage Patterns (B10)	
<input checked="" type="checkbox"/> Water Marks (B1)	<input type="checkbox"/> Aquatic Invertebrates (B13)	<input type="checkbox"/> Dry-Season Water Table (C2)	
<input type="checkbox"/> Sediment Deposits (B2)	<input type="checkbox"/> Hydrogen Sulfide Odor (C1)	<input type="checkbox"/> Saturation Visible on Aerial Imagery (C9)	
<input type="checkbox"/> Drift Deposits (B3)	<input type="checkbox"/> Oxidized Rhizospheres along Living Roots (C3)	<input type="checkbox"/> Geomorphic Position (D2)	
<input type="checkbox"/> Algal Mat or Crust (B4)	<input type="checkbox"/> Presence of Reduced Iron (C4)	<input type="checkbox"/> Shallow Aquitard (D3)	
<input type="checkbox"/> Iron Deposits (B5)	<input type="checkbox"/> Recent Iron Reduction in Tilled Soils (C6)	<input type="checkbox"/> FAC-Neutral Test (D5)	
<input type="checkbox"/> Surface Soil Cracks (B6)	<input type="checkbox"/> Stunted or Stresses Plants (D1) (LRR A)	<input type="checkbox"/> Raised Ant Mounds (D6) (LRR A)	
<input type="checkbox"/> Inundation Visible on Aerial Imagery (B7)	<input type="checkbox"/> Other (Explain in Remarks)	<input type="checkbox"/> Frost-Heave Hummocks (D7)	
<input type="checkbox"/> Sparsely Vegetated Concave Surface (B8)			
Field Observations:		Wetland Hydrology Present?	
Surface Water Present?	Yes <input type="checkbox"/> No <input checked="" type="checkbox"/>	Depth (inches):	_____
Water Table Present?	Yes <input checked="" type="checkbox"/> No <input type="checkbox"/>	Depth (inches):	<u>1 inch</u>
Saturation Present? (includes capillary fringe)	Yes <input checked="" type="checkbox"/> No <input type="checkbox"/>	Depth (inches):	<u>Surface</u>
Describe Recorded Data (stream gauge, monitoring well, aerial photos, previous inspections), if available:			
Remarks: Water table 1 inch from surface, majority of the wetland included standing water at the time of the investigation.			

WETLAND DETERMINATION DATA FORM – Western Mountains, Valleys, and Coast Region

Project Site: Sound Transit East Link Extension Project City/County: Bellevue/King Sampling Date: April 23, 2013
 Applicant/Owner: Sound Transit State: WA Sampling Point: BNSF Northwest SPU
 Investigator(s): C Douglas & J. Pursley Section, Township, Range: S29, T24N, R5E
 Landform (hillslope, terrace, etc.): Narrow area adjacent to RR Tracks Local relief (concave, convex, none): concave Slope (%): 0% to 2%
 Subregion (LRR): A Lat: 47.62N Long: 122.18W Datum: _____
 Soil Map Unit Name: Kitsap silt loam NWI classification: None Mapped
 Are climatic / hydrologic conditions on the site typical for this time of year? Yes No (If no, explain in Remarks.)
 Are Vegetation , Soil , or Hydrology , significantly disturbed? Are "Normal Circumstances" present? Yes No
 Are Vegetation , Soil , or Hydrology , naturally problematic? (If needed, explain any answers in Remarks.)

SUMMARY OF FINDINGS – Attach site map showing sampling point locations, transects, important features, etc.

Hydrophytic Vegetation Present?	Yes <input type="checkbox"/>	No <input checked="" type="checkbox"/>	Is the Sampled Area within a Wetland?	Yes <input type="checkbox"/>	No <input checked="" type="checkbox"/>
Hydric Soil Present?	Yes <input type="checkbox"/>	No <input checked="" type="checkbox"/>		Yes <input type="checkbox"/>	No <input checked="" type="checkbox"/>
Wetland Hydrology Present?	Yes <input type="checkbox"/>	No <input checked="" type="checkbox"/>		Yes <input type="checkbox"/>	No <input checked="" type="checkbox"/>
Remarks: Wetland BNSF Northwest is located adjacent to railroad tracks with commercial development located to the west. Wetland includes depressional and slope HGM classes. Jurisdictional ditch along railroad tracks hydrologically connects wetland to wetlands to the south.					

VEGETATION – Use scientific names of plants

Tree Stratum (Plot size: 30 foot radius)	Absolute % Cover	Dominant Species?	Indicator Status	Dominance Test Worksheet:																
1. _____	_____	_____	_____	Number of Dominant Species That Are OBL, FACW, or FAC: <u>0</u> (A) Total Number of Dominant Species Across All Strata: <u>0</u> (B) Percent of Dominant Species That Are OBL, FACW, or FAC: <u>0</u> (A/B)																
2. _____	_____	_____	_____																	
3. _____	_____	_____	_____																	
4. _____	_____	_____	_____																	
50% = <u>0</u> , 20% = <u>0</u>	<u>0</u>	= Total Cover		Prevalence Index worksheet: <table style="width: 100%; border: none;"> <tr> <td style="text-align: center;"><u>Total % Cover of:</u></td> <td style="text-align: center;"><u>Multiply by:</u></td> </tr> <tr> <td>OBL species _____</td> <td>x1 = _____</td> </tr> <tr> <td>FACW species _____</td> <td>x2 = _____</td> </tr> <tr> <td>FAC species _____</td> <td>x3 = _____</td> </tr> <tr> <td>FACU species _____</td> <td>x4 = _____</td> </tr> <tr> <td>UPL species _____</td> <td>x5 = _____</td> </tr> <tr> <td>Column Totals: _____ (A)</td> <td>_____ (B)</td> </tr> <tr> <td colspan="2" style="text-align: center;">Prevalence Index = B/A = _____</td> </tr> </table>	<u>Total % Cover of:</u>	<u>Multiply by:</u>	OBL species _____	x1 = _____	FACW species _____	x2 = _____	FAC species _____	x3 = _____	FACU species _____	x4 = _____	UPL species _____	x5 = _____	Column Totals: _____ (A)	_____ (B)	Prevalence Index = B/A = _____	
<u>Total % Cover of:</u>	<u>Multiply by:</u>																			
OBL species _____	x1 = _____																			
FACW species _____	x2 = _____																			
FAC species _____	x3 = _____																			
FACU species _____	x4 = _____																			
UPL species _____	x5 = _____																			
Column Totals: _____ (A)	_____ (B)																			
Prevalence Index = B/A = _____																				
<u>Sapling/Shrub Stratum (Plot size: 15 foot radius)</u>																				
1. _____	_____	_____	_____																	
2. _____	_____	_____	_____																	
3. _____	_____	_____	_____																	
4. _____	_____	_____	_____																	
5. _____	_____	_____	_____																	
50% = <u>0</u> , 20% = <u>0</u>	<u>0</u>	= Total Cover																		
<u>Herb Stratum (Plot size: 3 foot radius)</u>																				
1. _____	_____	_____	_____																	
2. _____	_____	_____	_____																	
3. _____	_____	_____	_____																	
4. _____	_____	_____	_____																	
5. _____	_____	_____	_____																	
6. _____	_____	_____	_____																	
7. _____	_____	_____	_____																	
8. _____	_____	_____	_____																	
9. _____	_____	_____	_____																	
10. _____	_____	_____	_____																	
11. _____	_____	_____	_____																	
50% = <u>0</u> , 20% = <u>0</u>	<u>0</u>	= Total Cover																		
<u>Woody Vine Stratum (Plot size: 3 foot radius)</u>																				
1. _____	_____	_____	_____																	
2. _____	_____	_____	_____																	
50% = _____, 20% = _____	<u>0</u>	= Total Cover																		
% Bare Ground in Herb Stratum <u>0</u>																				

Hydrophytic Vegetation Indicators:

1 – Rapid Test for Hydrophytic Vegetation

2 - Dominance Test is >50%

3 - Prevalence Index is $\leq 3.0^1$

4 - Morphological Adaptations¹ (Provide supporting data in Remarks or on a separate sheet)

5 - Wetland Non-Vascular Plants¹

Problematic Hydrophytic Vegetation¹ (Explain)

¹Indicators of hydric soil and wetland hydrology must be present, unless disturbed or problematic.

Hydrophytic Vegetation Present? Yes No

Remarks: 0% dominant wetland vegetation per the Dominance Test, upland plot in railroad tracks fill prism with 100% bare ground.

SOIL

Profile Description: (Describe to the depth needed to document the indicator or confirm the absence of indicators.)

Depth (inches)	Matrix		Redox Features				Texture	Remarks
	Color (moist)	%	Color (moist)	%	Type ¹	Loc ²		
0 to 18+	Fill prism	100	None	None	None	None	Fill prism	angular rock
_____	_____	_____	_____	_____	_____	_____	_____	_____
_____	_____	_____	_____	_____	_____	_____	_____	_____
_____	_____	_____	_____	_____	_____	_____	_____	_____
_____	_____	_____	_____	_____	_____	_____	_____	_____
_____	_____	_____	_____	_____	_____	_____	_____	_____

¹Type: C= Concentration, D=Depletion, RM=Reduced Matrix, CS=Covered or Coated Sand Grains. ²Location: PL=Pore Lining, M=Matrix

Hydric Soil Indicators: (Applicable to all LRRs, unless otherwise noted.)

- Histosol (A1)
- Histic Epipedon (A2)
- Black Histic (A3)
- Hydrogen Sulfide (A4)
- Depleted Below Dark Surface (A11)
- Thick Dark Surface (A12)
- Sandy Mucky Mineral (S1)
- Sandy Gleyed Matrix (S4)
- Sandy Redox (S5)
- Stripped Matrix (S6)
- Loamy Mucky Mineral (F1) **(except MLRA 1)**
- Loamy Gleyed Matrix (F2)
- Depleted Matrix (F3)
- Redox Dark Surface (F6)
- Depleted Dark Surface (F7)
- Redox Depressions (F8)

Indicators for Problematic Hydric Soils³:

- 2 cm Muck (A10)
- Red Parent Material (TF2)
- Very Shallow Dark Surface (TF12)
- Other (Explain in Remarks)

³Indicators of hydrophytic vegetation and wetland hydrology must be present, unless disturbed or problematic.

Restrictive Layer (if present):

Type: Angular rock fill prism

Depth (inches): Surface

Hydric Soils Present?

Yes No

Remarks: Angular rock railroad tracks fill prism

HYDROLOGY

Wetland Hydrology Indicators:

Primary Indicators (minimum of one required; check all that apply)

- Surface Water (A1)
- High Water Table (A2)
- Saturation (A3)
- Water Marks (B1)
- Sediment Deposits (B2)
- Drift Deposits (B3)
- Algal Mat or Crust (B4)
- Iron Deposits (B5)
- Surface Soil Cracks (B6)
- Inundation Visible on Aerial Imagery (B7)
- Sparsely Vegetated Concave Surface (B8)
- Water-Stained Leaves (B9) **(except MLRA 1, 2, 4A, and 4B)**
- Salt Crust (B11)
- Aquatic Invertebrates (B13)
- Hydrogen Sulfide Odor (C1)
- Oxidized Rhizospheres along Living Roots (C3)
- Presence of Reduced Iron (C4)
- Recent Iron Reduction in Tilled Soils (C6)
- Stunted or Stresses Plants (D1) **(LRR A)**
- Other (Explain in Remarks)

Secondary Indicators (2 or more required)

- Water-Stained Leaves (B9) **(MLRA 1, 2, 4A, and 4B)**
- Drainage Patterns (B10)
- Dry-Season Water Table (C2)
- Saturation Visible on Aerial Imagery (C9)
- Geomorphic Position (D2)
- Shallow Aquitard (D3)
- FAC-Neutral Test (D5)
- Raised Ant Mounds (D6) **(LRR A)**
- Frost-Heave Hummocks (D7)

Field Observations:

Surface Water Present? Yes No Depth (inches): _____
 Water Table Present? Yes No Depth (inches): _____
 Saturation Present?
 (includes capillary fringe) Yes No Depth (inches): _____

Wetland Hydrology Present? Yes No

Describe Recorded Data (stream gauge, monitoring well, aerial photos, previous inspections), if available:

Remarks: No saturation or water table observed in sample plot

WETLAND DETERMINATION DATA FORM – Western Mountains, Valleys, and Coast Region

Project Site: Sound Transit East Link Extension Project City/County: Bellevue/King Sampling Date: April 23, 2013
 Applicant/Owner: Sound Transit State: WA Sampling Point: BNSF Northwest SPW
 Investigator(s): C Douglas & J. Pursley Section, Township, Range: S29, T24N, R5E
 Landform (hillslope, terrace, etc.): Narrow area adjacent to RR Tracks Local relief (concave, convex, none): concave Slope (%): 0% to 2%
 Subregion (LRR): A Lat: 47.62N Long: 122.18W Datum: _____
 Soil Map Unit Name: Kitsap silt loam NWI classification: None Mapped
 Are climatic / hydrologic conditions on the site typical for this time of year? Yes No (If no, explain in Remarks.)
 Are Vegetation , Soil , or Hydrology , significantly disturbed? Are "Normal Circumstances" present? Yes No
 Are Vegetation , Soil , or Hydrology , naturally problematic? (If needed, explain any answers in Remarks.)

SUMMARY OF FINDINGS – Attach site map showing sampling point locations, transects, important features, etc.

Hydrophytic Vegetation Present?	Yes <input checked="" type="checkbox"/>	No <input type="checkbox"/>	Is the Sampled Area within a Wetland?		
Hydric Soil Present?	Yes <input checked="" type="checkbox"/>	No <input type="checkbox"/>		Yes <input checked="" type="checkbox"/>	No <input type="checkbox"/>
Wetland Hydrology Present?	Yes <input checked="" type="checkbox"/>	No <input type="checkbox"/>			
Remarks: Wetland BNSF Northwest is located adjacent to railroad tracks with commercial development located to the west. Wetland includes depressional and slope HGM classes. Jurisdictional ditch along railroad tracks hydrologically connects wetland to wetlands to the south.					

VEGETATION – Use scientific names of plants

Tree Stratum (Plot size: 30 foot radius)	Absolute % Cover	Dominant Species?	Indicator Status	Dominance Test Worksheet:																
1. <u><i>Salix lasiandra</i></u>	90	yes	FAC	Number of Dominant Species That Are OBL, FACW, or FAC: <u>3</u> (A) Total Number of Dominant Species Across All Strata: <u>6</u> (B) Percent of Dominant Species That Are OBL, FACW, or FAC: <u>50</u> (A/B)																
2. _____	_____	_____	_____																	
3. _____	_____	_____	_____																	
4. _____	_____	_____	_____																	
50% = 1, 20% = 0	90	= Total Cover																		
Sapling/Shrub Stratum (Plot size: 15 foot radius)				Prevalence Index worksheet: <table style="width: 100%; border: none;"> <tr> <td style="text-align: right;">Total % Cover of:</td> <td style="text-align: right;">Multiply by:</td> </tr> <tr> <td>OBL species _____</td> <td>x1 = _____</td> </tr> <tr> <td>FACW species _____</td> <td>x2 = _____</td> </tr> <tr> <td>FAC species _____</td> <td>x3 = _____</td> </tr> <tr> <td>FACU species _____</td> <td>x4 = _____</td> </tr> <tr> <td>UPL species _____</td> <td>x5 = _____</td> </tr> <tr> <td>Column Totals: _____ (A)</td> <td>_____ (B)</td> </tr> <tr> <td colspan="2" style="text-align: center;">Prevalence Index = B/A = _____</td> </tr> </table>	Total % Cover of:	Multiply by:	OBL species _____	x1 = _____	FACW species _____	x2 = _____	FAC species _____	x3 = _____	FACU species _____	x4 = _____	UPL species _____	x5 = _____	Column Totals: _____ (A)	_____ (B)	Prevalence Index = B/A = _____	
Total % Cover of:	Multiply by:																			
OBL species _____	x1 = _____																			
FACW species _____	x2 = _____																			
FAC species _____	x3 = _____																			
FACU species _____	x4 = _____																			
UPL species _____	x5 = _____																			
Column Totals: _____ (A)	_____ (B)																			
Prevalence Index = B/A = _____																				
1. <u><i>Rubus armeniacus</i></u>	10	yes	FACU																	
2. <u><i>Sambucus racemosa</i></u>	10	yes	FACU																	
3. _____	_____	_____	_____																	
4. _____	_____	_____	_____																	
5. _____	_____	_____	_____																	
50% = 2, 20% = 0	20	= Total Cover																		
Herb Stratum (Plot size: 3 foot radius)				Hydrophytic Vegetation Indicators: <input type="checkbox"/> 1 – Rapid Test for Hydrophytic Vegetation <input checked="" type="checkbox"/> 2 - Dominance Test is >50% <input type="checkbox"/> 3 - Prevalence Index is $\leq 3.0^1$ <input type="checkbox"/> 4 - Morphological Adaptations ¹ (Provide supporting data in Remarks or on a separate sheet) <input type="checkbox"/> 5 - Wetland Non-Vascular Plants ¹ <input type="checkbox"/> Problematic Hydrophytic Vegetation ¹ (Explain) ¹ Indicators of hydric soil and wetland hydrology must be present, unless disturbed or problematic.																
1. <u><i>Athyrium filix-femina</i></u>	60	yes	FAC																	
2. <u><i>Epilobium watsonii</i></u>	5	yes	FACW																	
3. <u><i>Equisetum arvense</i></u>	5	no	FAC																	
4. <u><i>Juncus effusus</i></u>	25	yes	FACW																	
5. <u><i>Lemna minor</i></u>	10	no	OBL																	
6. <u><i>Ludwigia palustris</i></u>	10	no	OBL																	
7. _____	_____	_____	_____																	
8. _____	_____	_____	_____																	
9. _____	_____	_____	_____																	
10. _____	_____	_____	_____																	
11. _____	_____	_____	_____																	
50% = 1, 20% = 2	100	= Total Cover																		
Woody Vine Stratum (Plot size: 3 foot radius)				Hydrophytic Vegetation Present? <table style="width: 100%; border: none;"> <tr> <td style="text-align: right;">Yes</td> <td style="text-align: center;"><input checked="" type="checkbox"/></td> <td style="text-align: right;">No</td> <td style="text-align: center;"><input type="checkbox"/></td> </tr> </table>	Yes	<input checked="" type="checkbox"/>	No	<input type="checkbox"/>												
Yes	<input checked="" type="checkbox"/>	No	<input type="checkbox"/>																	
1. <u><i>Hedera hibernica</i></u>	15	yes	UPL																	
2. _____	_____	_____	_____																	
50% = 1, 20% = 0	15	= Total Cover																		
% Bare Ground in Herb Stratum <u>100</u>																				

Remarks: 100% dominant wetland vegetation per the Dominance Test

SOIL

Profile Description: (Describe to the depth needed to document the indicator or confirm the absence of indicators.)								
Depth (inches)	Matrix		Redox Features				Texture	Remarks
	Color (moist)	%	Color (moist)	%	Type ¹	Loc ²		
<u>0 to 3</u>	<u>10YR 3/2</u>	<u>80</u>	<u>10YR 5/1</u>	<u>20</u>	<u>D</u>	<u>M</u>	<u>Silt loam</u>	
<u>3 to 18+</u>	<u>10YR 4/1</u>	<u>90</u>	<u>10YR 4/4</u>	<u>10</u>	<u>D</u>	<u>M</u>	<u>Sandy loam</u>	<u>w/gravel & cobble</u>
¹ Type: C= Concentration, D=Depletion, RM=Reduced Matrix, CS=Covered or Coated Sand Grains.			² Location: PL=Pore Lining, M=Matrix					
Hydric Soil Indicators: (Applicable to all LRRs, unless otherwise noted.)						Indicators for Problematic Hydric Soils³:		
<input type="checkbox"/> Histosol (A1)			<input checked="" type="checkbox"/> Sandy Redox (S5)			<input type="checkbox"/> 2 cm Muck (A10)		
<input type="checkbox"/> Histic Epipedon (A2)			<input type="checkbox"/> Stripped Matrix (S6)			<input type="checkbox"/> Red Parent Material (TF2)		
<input type="checkbox"/> Black Histic (A3)			<input type="checkbox"/> Loamy Mucky Mineral (F1) (except MLRA 1)			<input type="checkbox"/> Very Shallow Dark Surface (TF12)		
<input type="checkbox"/> Hydrogen Sulfide (A4)			<input type="checkbox"/> Loamy Gleyed Matrix (F2)			<input type="checkbox"/> Other (Explain in Remarks)		
<input type="checkbox"/> Depleted Below Dark Surface (A11)			<input checked="" type="checkbox"/> Depleted Matrix (F3)			³ Indicators of hydrophytic vegetation and wetland hydrology must be present, unless disturbed or problematic.		
<input checked="" type="checkbox"/> Thick Dark Surface (A12)			<input type="checkbox"/> Redox Dark Surface (F6)					
<input type="checkbox"/> Sandy Mucky Mineral (S1)			<input type="checkbox"/> Depleted Dark Surface (F7)					
<input type="checkbox"/> Sandy Gleyed Matrix (S4)			<input type="checkbox"/> Redox Depressions (F8)					
Restrictive Layer (if present):					Hydric Soils Present?			
Type: _____					Yes <input checked="" type="checkbox"/> No <input type="checkbox"/>			
Depth (inches): _____								
Remarks: 1 and 2 chroma with redox features								

HYDROLOGY

Wetland Hydrology Indicators:			
Primary Indicators (minimum of one required; check all that apply)		Secondary Indicators (2 or more required)	
<input type="checkbox"/> Surface Water (A1)	<input checked="" type="checkbox"/> Water-Stained Leaves (B9)	<input type="checkbox"/> Water-Stained Leaves (B9)	
<input checked="" type="checkbox"/> High Water Table (A2)	(except MLRA 1, 2, 4A, and 4B)	(MLRA 1, 2, 4A, and 4B)	
<input checked="" type="checkbox"/> Saturation (A3)	<input type="checkbox"/> Salt Crust (B11)	<input type="checkbox"/> Drainage Patterns (B10)	
<input type="checkbox"/> Water Marks (B1)	<input type="checkbox"/> Aquatic Invertebrates (B13)	<input type="checkbox"/> Dry-Season Water Table (C2)	
<input type="checkbox"/> Sediment Deposits (B2)	<input type="checkbox"/> Hydrogen Sulfide Odor (C1)	<input type="checkbox"/> Saturation Visible on Aerial Imagery (C9)	
<input type="checkbox"/> Drift Deposits (B3)	<input type="checkbox"/> Oxidized Rhizospheres along Living Roots (C3)	<input type="checkbox"/> Geomorphic Position (D2)	
<input type="checkbox"/> Algal Mat or Crust (B4)	<input type="checkbox"/> Presence of Reduced Iron (C4)	<input type="checkbox"/> Shallow Aquitard (D3)	
<input type="checkbox"/> Iron Deposits (B5)	<input type="checkbox"/> Recent Iron Reduction in Tilled Soils (C6)	<input type="checkbox"/> FAC-Neutral Test (D5)	
<input type="checkbox"/> Surface Soil Cracks (B6)	<input type="checkbox"/> Stunted or Stresses Plants (D1) (LRR A)	<input type="checkbox"/> Raised Ant Mounds (D6) (LRR A)	
<input type="checkbox"/> Inundation Visible on Aerial Imagery (B7)	<input type="checkbox"/> Other (Explain in Remarks)	<input type="checkbox"/> Frost-Heave Hummocks (D7)	
<input type="checkbox"/> Sparsely Vegetated Concave Surface (B8)			
Field Observations:		Wetland Hydrology Present?	
Surface Water Present? Yes <input type="checkbox"/> No <input checked="" type="checkbox"/>	Depth (inches): _____	Yes <input checked="" type="checkbox"/> No <input type="checkbox"/>	
Water Table Present? Yes <input checked="" type="checkbox"/> No <input type="checkbox"/>	Depth (inches): <u>8 inches</u>		
Saturation Present? (includes capillary fringe) Yes <input checked="" type="checkbox"/> No <input type="checkbox"/>	Depth (inches): <u>Surface</u>		
Describe Recorded Data (stream gauge, monitoring well, aerial photos, previous inspections), if available:			
Remarks: Saturation and water table observed in sample plot			

WETLAND DETERMINATION DATA FORM – Western Mountains, Valleys, and Coast Region

Project Site: Sound Transit East Link Extension Project City/County: Bellevue/King Sampling Date: April 23, 2013
 Applicant/Owner: Sound Transit State: WA Sampling Point: BNSF Southwest SPW
 Investigator(s): C Douglas & J. Pursley Section, Township, Range: S29, T24N, R5E
 Landform (hillslope, terrace, etc.): Area adjacent to RR Tracks Local relief (concave, convex, none): concave Slope (%): 0% to 2%
 Subregion (LRR): A Lat: 47.62N Long: 122.18W Datum: _____
 Soil Map Unit Name: Alderwood gravelly sandy loam NWI classification: None Mapped
 Are climatic / hydrologic conditions on the site typical for this time of year? Yes No (If no, explain in Remarks.)
 Are Vegetation , Soil , or Hydrology , significantly disturbed? Are "Normal Circumstances" present? Yes No
 Are Vegetation , Soil , or Hydrology , naturally problematic? (If needed, explain any answers in Remarks.)

SUMMARY OF FINDINGS – Attach site map showing sampling point locations, transects, important features, etc.

Hydrophytic Vegetation Present?	Yes <input checked="" type="checkbox"/>	No <input type="checkbox"/>	Is the Sampled Area within a Wetland?		
Hydric Soil Present?	Yes <input type="checkbox"/>	No <input checked="" type="checkbox"/>		Yes <input type="checkbox"/>	No <input checked="" type="checkbox"/>
Wetland Hydrology Present?	Yes <input type="checkbox"/>	No <input checked="" type="checkbox"/>			
Remarks: Wetland BNSF Southwest is located adjacent to railroad tracks with commercial development located to the west. Wetland includes depressional and slope HGM classes. Jurisdictional ditch along railroad tracks hydrologically connects wetland to wetlands to the north.					

VEGETATION – Use scientific names of plants

Tree Stratum (Plot size: 30 foot radius)	Absolute % Cover	Dominant Species?	Indicator Status	Dominance Test Worksheet:																
1. _____	_____	_____	_____	Number of Dominant Species That Are OBL, FACW, or FAC: <u>1</u> (A) Total Number of Dominant Species Across All Strata: <u>3</u> (B) Percent of Dominant Species That Are OBL, FACW, or FAC: <u>37</u> (A/B)																
2. _____	_____	_____	_____																	
3. _____	_____	_____	_____																	
4. _____	_____	_____	_____																	
50% = <u>0</u> , 20% = <u>0</u>	<u>0</u>	= Total Cover		Prevalence Index worksheet: <table style="width: 100%; border: none;"> <tr> <td style="width: 50%; text-align: center;">Total % Cover of:</td> <td style="width: 50%; text-align: center;">Multiply by:</td> </tr> <tr> <td>OBL species _____</td> <td>x1 = _____</td> </tr> <tr> <td>FACW species _____</td> <td>x2 = _____</td> </tr> <tr> <td>FAC species _____</td> <td>x3 = _____</td> </tr> <tr> <td>FACU species _____</td> <td>x4 = _____</td> </tr> <tr> <td>UPL species _____</td> <td>x5 = _____</td> </tr> <tr> <td>Column Totals: _____ (A)</td> <td>_____ (B)</td> </tr> <tr> <td colspan="2" style="text-align: center;">Prevalence Index = B/A = _____</td> </tr> </table>	Total % Cover of:	Multiply by:	OBL species _____	x1 = _____	FACW species _____	x2 = _____	FAC species _____	x3 = _____	FACU species _____	x4 = _____	UPL species _____	x5 = _____	Column Totals: _____ (A)	_____ (B)	Prevalence Index = B/A = _____	
Total % Cover of:	Multiply by:																			
OBL species _____	x1 = _____																			
FACW species _____	x2 = _____																			
FAC species _____	x3 = _____																			
FACU species _____	x4 = _____																			
UPL species _____	x5 = _____																			
Column Totals: _____ (A)	_____ (B)																			
Prevalence Index = B/A = _____																				
<u>Sapling/Shrub Stratum (Plot size: 15 foot radius)</u>																				
1. <u>Cytisus scoparius</u>	<u>40</u>	<u>yes</u>	<u>UPL</u>																	
2. <u>Rubus armeniacus</u>	<u>20</u>	<u>yes</u>	<u>FACU</u>																	
3. _____	_____	_____	_____																	
4. _____	_____	_____	_____																	
5. _____	_____	_____	_____																	
50% = <u>1</u> , 20% = <u>1</u>	<u>60</u>	= Total Cover																		
<u>Herb Stratum (Plot size: 3 foot radius)</u>																				
1. <u>Agrostis capillaris</u>	<u>60</u>	<u>yes</u>	<u>FAC</u>																	
2. <u>Phalaris arundinacea</u>	<u>5</u>	<u>no</u>	<u>FACW</u>																	
3. <u>Tanacetum vulgare</u>	<u>5</u>	<u>no</u>	<u>UPL</u>																	
4. <u>Trifolium pratense</u>	<u>10</u>	<u>no</u>	<u>FACU</u>																	
5. _____	_____	_____	_____																	
6. _____	_____	_____	_____																	
7. _____	_____	_____	_____																	
8. _____	_____	_____	_____																	
9. _____	_____	_____	_____																	
10. _____	_____	_____	_____																	
11. _____	_____	_____	_____																	
50% = <u>1</u> , 20% = <u>0</u>	<u>80</u>	= Total Cover																		
<u>Woody Vine Stratum (Plot size: 3 foot radius)</u>																				
1. _____	_____	_____	_____																	
2. _____	_____	_____	_____																	
50% = _____, 20% = _____	<u>0</u>	= Total Cover																		
% Bare Ground in Herb Stratum <u>0</u>																				
Hydrophytic Vegetation Indicators: <input type="checkbox"/> 1 – Rapid Test for Hydrophytic Vegetation <input checked="" type="checkbox"/> 2 - Dominance Test is >50% <input type="checkbox"/> 3 - Prevalence Index is ≤3.0 ¹ <input type="checkbox"/> 4 - Morphological Adaptations ¹ (Provide supporting data in Remarks or on a separate sheet) <input type="checkbox"/> 5 - Wetland Non-Vascular Plants ¹ <input type="checkbox"/> Problematic Hydrophytic Vegetation ¹ (Explain) ¹ Indicators of hydric soil and wetland hydrology must be present, unless disturbed or problematic.																				
Hydrophytic Vegetation Present? Yes <input type="checkbox"/> No <input checked="" type="checkbox"/>																				

Remarks: 37% dominant wetland vegetation per the Dominance Test.

WETLAND DETERMINATION DATA FORM – Western Mountains, Valleys, and Coast Region

Project Site: Sound Transit East Link Extension Project City/County: Bellevue/King Sampling Date: April 23, 2013
 Applicant/Owner: Sound Transit State: WA Sampling Point: BNSF Southwest SPW
 Investigator(s): C Douglas & J. Pursley Section, Township, Range: S29, T24N, R5E
 Landform (hillslope, terrace, etc.): Area adjacent to RR Tracks Local relief (concave, convex, none): concave Slope (%): 0% to 2%
 Subregion (LRR): A Lat: 47.62N Long: 122.18W Datum: _____
 Soil Map Unit Name: Alderwood gravelly sandy loam NWI classification: None Mapped
 Are climatic / hydrologic conditions on the site typical for this time of year? Yes No (If no, explain in Remarks.)
 Are Vegetation , Soil , or Hydrology , significantly disturbed? Are "Normal Circumstances" present? Yes No
 Are Vegetation , Soil , or Hydrology , naturally problematic? (If needed, explain any answers in Remarks.)

SUMMARY OF FINDINGS – Attach site map showing sampling point locations, transects, important features, etc.

Hydrophytic Vegetation Present?	Yes <input checked="" type="checkbox"/>	No <input type="checkbox"/>	Is the Sampled Area within a Wetland?	Yes <input checked="" type="checkbox"/>	No <input type="checkbox"/>
Hydric Soil Present?	Yes <input checked="" type="checkbox"/>	No <input type="checkbox"/>		Yes <input checked="" type="checkbox"/>	No <input type="checkbox"/>
Wetland Hydrology Present?	Yes <input checked="" type="checkbox"/>	No <input type="checkbox"/>		Yes <input checked="" type="checkbox"/>	No <input type="checkbox"/>
Remarks: Wetland BNSF Southwest is located adjacent to railroad tracks with commercial development located to the west. Wetland includes depressional and slope HGM classes. Jurisdictional ditch along railroad tracks hydrologically connects wetland to wetlands to the north.					

VEGETATION – Use scientific names of plants

Tree Stratum (Plot size: 30 foot radius)	Absolute % Cover	Dominant Species?	Indicator Status	Dominance Test Worksheet:
1. _____	_____	_____	_____	Number of Dominant Species That Are OBL, FACW, or FAC: <u>1</u> (A) Total Number of Dominant Species Across All Strata: <u>1</u> (B) Percent of Dominant Species That Are OBL, FACW, or FAC: <u>100</u> (A/B)
2. _____	_____	_____	_____	
3. _____	_____	_____	_____	
4. _____	_____	_____	_____	
50% = <u>0</u> , 20% = <u>0</u>	<u>0</u>	= Total Cover		
Sapling/Shrub Stratum (Plot size: 15 foot radius)				Prevalence Index worksheet: Total % Cover of: _____ Multiply by: OBL species _____ x1 = _____ FACW species _____ x2 = _____ FAC species _____ x3 = _____ FACU species _____ x4 = _____ UPL species _____ x5 = _____ Column Totals: _____ (A) _____ (B) Prevalence Index = B/A = _____
1. _____	_____	_____	_____	
2. _____	_____	_____	_____	
3. _____	_____	_____	_____	
4. _____	_____	_____	_____	
5. _____	_____	_____	_____	
50% = <u>0</u> , 20% = <u>0</u>	<u>0</u>	= Total Cover		
Herb Stratum (Plot size: 3 foot radius)				Hydrophytic Vegetation Indicators: <input type="checkbox"/> 1 – Rapid Test for Hydrophytic Vegetation <input checked="" type="checkbox"/> 2 - Dominance Test is >50% <input type="checkbox"/> 3 - Prevalence Index is ≤3.0 ¹ <input type="checkbox"/> 4 - Morphological Adaptations ¹ (Provide supporting data in Remarks or on a separate sheet) <input type="checkbox"/> 5 - Wetland Non-Vascular Plants ¹ <input type="checkbox"/> Problematic Hydrophytic Vegetation ¹ (Explain) ¹ Indicators of hydric soil and wetland hydrology must be present, unless disturbed or problematic.
1. <u>Agrostis capillaris</u>	<u>60</u>	<u>yes</u>	<u>FAC</u>	
2. <u>Dipsacus fullonum</u>	<u>1</u>	<u>no</u>	<u>FAC</u>	
3. <u>Phalaris arundinacea</u>	<u>20</u>	<u>no</u>	<u>FACW</u>	
4. <u>Poa pratensis</u>	<u>20</u>	<u>no</u>	<u>FAC</u>	
5. <u>Rumex crispus</u>	<u>1</u>	<u>no</u>	<u>FAC</u>	
6. _____	_____	_____	_____	
7. _____	_____	_____	_____	
8. _____	_____	_____	_____	
9. _____	_____	_____	_____	
10. _____	_____	_____	_____	
11. _____	_____	_____	_____	
50% = <u>1</u> , 20% = <u>0</u>	<u>100</u>	= Total Cover		
Woody Vine Stratum (Plot size: 3 foot radius)				Hydrophytic Vegetation Present? Yes <input checked="" type="checkbox"/> No <input type="checkbox"/>
1. _____	_____	_____	_____	
2. _____	_____	_____	_____	
50% = _____, 20% = _____	<u>0</u>	= Total Cover		
% Bare Ground in Herb Stratum <u>0</u>				

Remarks: 100% dominant wetland vegetation per the Dominance Test

SOIL
SPW

Sampling Point: BNSF Southwest

Profile Description: (Describe to the depth needed to document the indicator or confirm the absence of indicators.)								
Depth (inches)	Matrix		Redox Features				Texture	Remarks
	Color (moist)	%	Color (moist)	%	Type ¹	Loc ²		
<u>0 to 2</u>	<u>10YR 4/2</u>	<u>100</u>	<u>None</u>	<u>None</u>	<u>None</u>	<u>None</u>	<u>Sandy silt</u>	<u>w/gravel</u>
<u>2 to 6</u>	<u>10YR 4/2</u>	<u>70</u>	<u>10YR 5/1</u>	<u>30</u>	<u>D</u>	<u>M</u>	<u>Sandy silt</u>	<u>w/gravel & cobble</u>
<u>6 to 18+</u>	<u>10YR 4/2</u>	<u>60</u>	<u>10YR 5/1</u>	<u>40</u>	<u>D</u>	<u>M</u>	<u>Sandy silt</u>	<u>w/gravel</u>
_____	_____	_____	_____	_____	_____	_____	_____	_____
_____	_____	_____	_____	_____	_____	_____	_____	_____
_____	_____	_____	_____	_____	_____	_____	_____	_____
_____	_____	_____	_____	_____	_____	_____	_____	_____

¹Type: C= Concentration, D=Depletion, RM=Reduced Matrix, CS=Covered or Coated Sand Grains. ²Location: PL=Pore Lining, M=Matrix

Hydric Soil Indicators: (Applicable to all LRRs, unless otherwise noted.)		Indicators for Problematic Hydric Soils ³ :	
<input type="checkbox"/> Histosol (A1)	<input type="checkbox"/> Sandy Redox (S5)	<input type="checkbox"/> 2 cm Muck (A10)	
<input type="checkbox"/> Histic Epipedon (A2)	<input type="checkbox"/> Stripped Matrix (S6)	<input type="checkbox"/> Red Parent Material (TF2)	
<input type="checkbox"/> Black Histic (A3)	<input type="checkbox"/> Loamy Mucky Mineral (F1) (except MLRA 1)	<input type="checkbox"/> Very Shallow Dark Surface (TF12)	
<input type="checkbox"/> Hydrogen Sulfide (A4)	<input type="checkbox"/> Loamy Gleyed Matrix (F2)	<input type="checkbox"/> Other (Explain in Remarks)	
<input type="checkbox"/> Depleted Below Dark Surface (A11)	<input checked="" type="checkbox"/> Depleted Matrix (F3)		
<input checked="" type="checkbox"/> Thick Dark Surface (A12)	<input type="checkbox"/> Redox Dark Surface (F6)		
<input type="checkbox"/> Sandy Mucky Mineral (S1)	<input type="checkbox"/> Depleted Dark Surface (F7)		
<input type="checkbox"/> Sandy Gleyed Matrix (S4)	<input type="checkbox"/> Redox Depressions (F8)		

³Indicators of hydrophytic vegetation and wetland hydrology must be present, unless disturbed or problematic.

Restrictive Layer (if present): Type: _____ Depth (inches): _____	Hydric Soils Present? Yes <input checked="" type="checkbox"/> No <input type="checkbox"/>
--	--

Remarks: 2 chroma with redox

HYDROLOGY

Wetland Hydrology Indicators:	
Primary Indicators (minimum of one required; check all that apply)	Secondary Indicators (2 or more required)
<input type="checkbox"/> Surface Water (A1)	<input checked="" type="checkbox"/> Water-Stained Leaves (B9)
<input checked="" type="checkbox"/> High Water Table (A2)	(except MLRA 1, 2, 4A, and 4B)
<input checked="" type="checkbox"/> Saturation (A3)	<input type="checkbox"/> Salt Crust (B11)
<input type="checkbox"/> Water Marks (B1)	<input type="checkbox"/> Aquatic Invertebrates (B13)
<input type="checkbox"/> Sediment Deposits (B2)	<input type="checkbox"/> Hydrogen Sulfide Odor (C1)
<input type="checkbox"/> Drift Deposits (B3)	<input type="checkbox"/> Oxidized Rhizospheres along Living Roots (C3)
<input type="checkbox"/> Algal Mat or Crust (B4)	<input type="checkbox"/> Presence of Reduced Iron (C4)
<input type="checkbox"/> Iron Deposits (B5)	<input type="checkbox"/> Recent Iron Reduction in Tilled Soils (C6)
<input type="checkbox"/> Surface Soil Cracks (B6)	<input type="checkbox"/> Stunted or Stresses Plants (D1) (LRR A)
<input type="checkbox"/> Inundation Visible on Aerial Imagery (B7)	<input type="checkbox"/> Other (Explain in Remarks)
<input type="checkbox"/> Sparsely Vegetated Concave Surface (B8)	<input type="checkbox"/> Water-Stained Leaves (B9)
	(MLRA 1, 2, 4A, and 4B)
	<input type="checkbox"/> Drainage Patterns (B10)
	<input type="checkbox"/> Dry-Season Water Table (C2)
	<input type="checkbox"/> Saturation Visible on Aerial Imagery (C9)
	<input type="checkbox"/> Geomorphic Position (D2)
	<input type="checkbox"/> Shallow Aquitard (D3)
	<input type="checkbox"/> FAC-Neutral Test (D5)
	<input type="checkbox"/> Raised Ant Mounds (D6) (LRR A)
	<input type="checkbox"/> Frost-Heave Hummocks (D7)

Field Observations: Surface Water Present? Yes <input type="checkbox"/> No <input checked="" type="checkbox"/> Depth (inches): _____ Water Table Present? Yes <input checked="" type="checkbox"/> No <input type="checkbox"/> Depth (inches): <u>6 inches</u> Saturation Present? (includes capillary fringe) Yes <input checked="" type="checkbox"/> No <input type="checkbox"/> Depth (inches): <u>Surface</u>	Wetland Hydrology Present? Yes <input checked="" type="checkbox"/> No <input type="checkbox"/>
--	---

Describe Recorded Data (stream gauge, monitoring well, aerial photos, previous inspections), if available:

Remarks: Saturation and water table observed in sample plot

WETLAND DETERMINATION DATA FORM – Western Mountains, Valleys, and Coast Region

Project Site: Sound Transit East Link Extension Project City/County: Bellevue/King Sampling Date: April 23, 2013
 Applicant/Owner: Sound Transit State: WA Sampling Point: BNSF West SP1W
 Investigator(s): C Douglas & J. Pursley Section, Township, Range: S29, T24N, R5E
 Landform (hillslope, terrace, etc.): Area adjacent to RR Tracks Local relief (concave, convex, none): concave Slope (%): 0% to 2%
 Subregion (LRR): A Lat: 47.62N Long: 122.18W Datum: _____
 Soil Map Unit Name: Alderwood gravelly sandy loam & Kitsap silt loam NWI classification: None Mapped
 Are climatic / hydrologic conditions on the site typical for this time of year? Yes No (If no, explain in Remarks.)
 Are Vegetation , Soil , or Hydrology , significantly disturbed? Are "Normal Circumstances" present? Yes No
 Are Vegetation , Soil , or Hydrology , naturally problematic? (If needed, explain any answers in Remarks.)

SUMMARY OF FINDINGS – Attach site map showing sampling point locations, transects, important features, etc.

Hydrophytic Vegetation Present?	Yes <input checked="" type="checkbox"/>	No <input type="checkbox"/>	Is the Sampled Area within a Wetland?	Yes <input checked="" type="checkbox"/>	No <input type="checkbox"/>
Hydric Soil Present?	Yes <input checked="" type="checkbox"/>	No <input type="checkbox"/>		Yes <input checked="" type="checkbox"/>	No <input type="checkbox"/>
Wetland Hydrology Present?	Yes <input checked="" type="checkbox"/>	No <input type="checkbox"/>		Yes <input checked="" type="checkbox"/>	No <input type="checkbox"/>
Remarks: Wetland BNSF West is located adjacent to railroad tracks with commercial development located to the west. Wetland includes depressional and slope HGM classes. Jurisdictional ditch along railroad tracks hydrologically connects wetland to wetlands to the north and south.					

VEGETATION – Use scientific names of plants

Tree Stratum (Plot size: 30 foot radius)	Absolute % Cover	Dominant Species?	Indicator Status	Dominance Test Worksheet:																
1. <u><i>Salix scouleriana</i></u>	<u>60</u>	<u>yes</u>	<u>FAC</u>	Number of Dominant Species That Are OBL, FACW, or FAC: <u>5</u> (A) Total Number of Dominant Species Across All Strata: <u>5</u> (B) Percent of Dominant Species That Are OBL, FACW, or FAC: <u>100</u> (A/B)																
2. _____	_____	_____	_____																	
3. _____	_____	_____	_____																	
4. _____	_____	_____	_____																	
50% = <u>1</u> , 20% = <u>0</u>	<u>60</u>	= Total Cover																		
<u>Sapling/Shrub Stratum (Plot size: 15 foot radius)</u>				Prevalence Index worksheet: <table style="width: 100%; border: none;"> <tr> <td style="text-align: right;">Total % Cover of:</td> <td style="text-align: right;">Multiply by:</td> </tr> <tr> <td>OBL species _____</td> <td>x1 = _____</td> </tr> <tr> <td>FACW species _____</td> <td>x2 = _____</td> </tr> <tr> <td>FAC species _____</td> <td>x3 = _____</td> </tr> <tr> <td>FACU species _____</td> <td>x4 = _____</td> </tr> <tr> <td>UPL species _____</td> <td>x5 = _____</td> </tr> <tr> <td>Column Totals: _____ (A)</td> <td>_____ (B)</td> </tr> <tr> <td colspan="2" style="text-align: center;">Prevalence Index = B/A = _____</td> </tr> </table>	Total % Cover of:	Multiply by:	OBL species _____	x1 = _____	FACW species _____	x2 = _____	FAC species _____	x3 = _____	FACU species _____	x4 = _____	UPL species _____	x5 = _____	Column Totals: _____ (A)	_____ (B)	Prevalence Index = B/A = _____	
Total % Cover of:	Multiply by:																			
OBL species _____	x1 = _____																			
FACW species _____	x2 = _____																			
FAC species _____	x3 = _____																			
FACU species _____	x4 = _____																			
UPL species _____	x5 = _____																			
Column Totals: _____ (A)	_____ (B)																			
Prevalence Index = B/A = _____																				
1. <u><i>Spiraea douglasii</i></u>	<u>40</u>	<u>yes</u>	<u>FACW</u>																	
2. _____	_____	_____	_____																	
3. _____	_____	_____	_____																	
4. _____	_____	_____	_____																	
5. _____	_____	_____	_____																	
50% = <u>1</u> , 20% = <u>0</u>	<u>40</u>	= Total Cover																		
<u>Herb Stratum (Plot size: 3 foot radius)</u>				Hydrophytic Vegetation Indicators: <input type="checkbox"/> 1 – Rapid Test for Hydrophytic Vegetation <input checked="" type="checkbox"/> 2 - Dominance Test is >50% <input type="checkbox"/> 3 - Prevalence Index is $\leq 3.0^1$ <input type="checkbox"/> 4 - Morphological Adaptations ¹ (Provide supporting data in Remarks or on a separate sheet) <input type="checkbox"/> 5 - Wetland Non-Vascular Plants ¹ <input type="checkbox"/> Problematic Hydrophytic Vegetation ¹ (Explain) ¹ Indicators of hydric soil and wetland hydrology must be present, unless disturbed or problematic.																
1. <u><i>Agrostis capillaris</i></u>	<u>10</u>	<u>yes</u>	<u>FAC</u>																	
2. <u><i>Athyrium filix-femina</i></u>	<u>15</u>	<u>yes</u>	<u>FAC</u>																	
3. <u><i>Phalaris arundinacea</i></u>	<u>20</u>	<u>yes</u>	<u>FACW</u>																	
4. _____	_____	_____	_____																	
5. _____	_____	_____	_____																	
6. _____	_____	_____	_____																	
7. _____	_____	_____	_____																	
8. _____	_____	_____	_____																	
9. _____	_____	_____	_____																	
10. _____	_____	_____	_____																	
11. _____	_____	_____	_____																	
50% = <u>0</u> , 20% = <u>3</u>	<u>45</u>	= Total Cover																		
<u>Woody Vine Stratum (Plot size: 3 foot radius)</u>																				
1. _____	_____	_____	_____																	
2. _____	_____	_____	_____																	
50% = _____, 20% = _____	<u>0</u>	= Total Cover																		
% Bare Ground in Herb Stratum <u>55</u>																				

Remarks: 100% dominant wetland vegetation per the Dominance Test

SOIL

Profile Description: (Describe to the depth needed to document the indicator or confirm the absence of indicators.)								
Depth (inches)	Matrix		Redox Features				Texture	Remarks
	Color (moist)	%	Color (moist)	%	Type ¹	Loc ²		
0 to 3	10YR 4/1	100	None	None	None	None	Silt loam	
3 to 4	10YR 4/1	60	10YR 5/6	40	D	M	Silt loam	w/gravel & cobble
4 to 18+	10YR 4/1	60	10YR 5/6	40	D	M	Silt loam	w/gravel
_____	_____	_____	_____	_____	_____	_____	_____	_____
_____	_____	_____	_____	_____	_____	_____	_____	_____
_____	_____	_____	_____	_____	_____	_____	_____	_____
_____	_____	_____	_____	_____	_____	_____	_____	_____

¹Type: C= Concentration, D=Depletion, RM=Reduced Matrix, CS=Covered or Coated Sand Grains. ²Location: PL=Pore Lining, M=Matrix

Hydric Soil Indicators: (Applicable to all LRRs, unless otherwise noted.)				Indicators for Problematic Hydric Soils ³ :	
<input type="checkbox"/>	Histosol (A1)	<input type="checkbox"/>	Sandy Redox (S5)	<input type="checkbox"/>	2 cm Muck (A10)
<input type="checkbox"/>	Histic Epipedon (A2)	<input type="checkbox"/>	Stripped Matrix (S6)	<input type="checkbox"/>	Red Parent Material (TF2)
<input type="checkbox"/>	Black Histic (A3)	<input type="checkbox"/>	Loamy Mucky Mineral (F1) (except MLRA 1)	<input type="checkbox"/>	Very Shallow Dark Surface (TF12)
<input type="checkbox"/>	Hydrogen Sulfide (A4)	<input type="checkbox"/>	Loamy Gleyed Matrix (F2)	<input type="checkbox"/>	Other (Explain in Remarks)
<input type="checkbox"/>	Depleted Below Dark Surface (A11)	<input checked="" type="checkbox"/>	Depleted Matrix (F3)		
<input checked="" type="checkbox"/>	Thick Dark Surface (A12)	<input type="checkbox"/>	Redox Dark Surface (F6)		
<input type="checkbox"/>	Sandy Mucky Mineral (S1)	<input type="checkbox"/>	Depleted Dark Surface (F7)		
<input type="checkbox"/>	Sandy Gleyed Matrix (S4)	<input type="checkbox"/>	Redox Depressions (F8)		

³Indicators of hydrophytic vegetation and wetland hydrology must be present, unless disturbed or problematic.

Restrictive Layer (if present):		Hydric Soils Present?	
Type: _____	Depth (inches): _____	Yes	<input checked="" type="checkbox"/> No <input type="checkbox"/>

Remarks: 1 chroma with redox

HYDROLOGY

Wetland Hydrology Indicators:			
Primary Indicators (minimum of one required; check all that apply)		Secondary Indicators (2 or more required)	
<input type="checkbox"/>	Surface Water (A1)	<input checked="" type="checkbox"/>	Water-Stained Leaves (B9)
<input checked="" type="checkbox"/>	High Water Table (A2)		(except MLRA 1, 2, 4A, and 4B)
<input checked="" type="checkbox"/>	Saturation (A3)	<input type="checkbox"/>	Salt Crust (B11)
<input type="checkbox"/>	Water Marks (B1)	<input type="checkbox"/>	Aquatic Invertebrates (B13)
<input type="checkbox"/>	Sediment Deposits (B2)	<input type="checkbox"/>	Hydrogen Sulfide Odor (C1)
<input type="checkbox"/>	Drift Deposits (B3)	<input type="checkbox"/>	Oxidized Rhizospheres along Living Roots (C3)
<input type="checkbox"/>	Algal Mat or Crust (B4)	<input type="checkbox"/>	Presence of Reduced Iron (C4)
<input type="checkbox"/>	Iron Deposits (B5)	<input type="checkbox"/>	Recent Iron Reduction in Tilled Soils (C6)
<input type="checkbox"/>	Surface Soil Cracks (B6)	<input type="checkbox"/>	Stunted or Stresses Plants (D1) (LRR A)
<input type="checkbox"/>	Inundation Visible on Aerial Imagery (B7)	<input type="checkbox"/>	Other (Explain in Remarks)
<input type="checkbox"/>	Sparsely Vegetated Concave Surface (B8)		

Field Observations:		Wetland Hydrology Present?	
Surface Water Present?	Yes <input type="checkbox"/> No <input checked="" type="checkbox"/>	Yes	<input checked="" type="checkbox"/> No <input type="checkbox"/>
Water Table Present?	Yes <input checked="" type="checkbox"/> No <input type="checkbox"/>		
Saturation Present? (includes capillary fringe)	Yes <input checked="" type="checkbox"/> No <input type="checkbox"/>		

Describe Recorded Data (stream gauge, monitoring well, aerial photos, previous inspections), if available:

Remarks: Saturation and water table observed in sample plot

WETLAND DETERMINATION DATA FORM – Western Mountains, Valleys, and Coast Region

Project Site: Sound Transit East Link Extension Project City/County: Bellevue/King Sampling Date: April 23, 2013
 Applicant/Owner: Sound Transit State: WA Sampling Point: BNSF West SP2U
 Investigator(s): C Douglas & J. Pursley Section, Township, Range: S29, T24N, R5E
 Landform (hillslope, terrace, etc.): Area adjacent to RR Tracks Local relief (concave, convex, none): concave Slope (%): 0% to 2%
 Subregion (LRR): A Lat: 47.62N Long: 122.18W Datum: _____
 Soil Map Unit Name: Alderwood gravelly sandy loam & Kitsap silt loam NWI classification: None Mapped
 Are climatic / hydrologic conditions on the site typical for this time of year? Yes No (If no, explain in Remarks.)
 Are Vegetation , Soil , or Hydrology , significantly disturbed? Are "Normal Circumstances" present? Yes No
 Are Vegetation , Soil , or Hydrology , naturally problematic? (If needed, explain any answers in Remarks.)

SUMMARY OF FINDINGS – Attach site map showing sampling point locations, transects, important features, etc.

Hydrophytic Vegetation Present?	Yes <input checked="" type="checkbox"/>	No <input type="checkbox"/>	Is the Sampled Area within a Wetland?		
Hydric Soil Present?	Yes <input type="checkbox"/>	No <input checked="" type="checkbox"/>		Yes <input type="checkbox"/>	No <input checked="" type="checkbox"/>
Wetland Hydrology Present?	Yes <input type="checkbox"/>	No <input checked="" type="checkbox"/>			
Remarks: Wetland BNSF West is located adjacent to railroad tracks with commercial development located to the west. Wetland includes depressional and slope HGM classes. Jurisdictional ditch along railroad tracks hydrologically connects wetland to wetlands to the north and south.					

VEGETATION – Use scientific names of plants

Tree Stratum (Plot size: 30 foot radius)	Absolute % Cover	Dominant Species?	Indicator Status	Dominance Test Worksheet:																
1. _____	_____	_____	_____	Number of Dominant Species That Are OBL, FACW, or FAC: 1 (A) Total Number of Dominant Species Across All Strata: 3 (B) Percent of Dominant Species That Are OBL, FACW, or FAC: 37 (A/B)																
2. _____	_____	_____	_____																	
3. _____	_____	_____	_____																	
4. _____	_____	_____	_____																	
50% = 0, 20% = 0	0	= Total Cover		Prevalence Index worksheet: <table style="width: 100%; border: none;"> <tr> <td style="text-align: center;">Total % Cover of:</td> <td style="text-align: center;">Multiply by:</td> </tr> <tr> <td>OBL species _____</td> <td>x1 = _____</td> </tr> <tr> <td>FACW species _____</td> <td>x2 = _____</td> </tr> <tr> <td>FAC species _____</td> <td>x3 = _____</td> </tr> <tr> <td>FACU species _____</td> <td>x4 = _____</td> </tr> <tr> <td>UPL species _____</td> <td>x5 = _____</td> </tr> <tr> <td>Column Totals: _____ (A)</td> <td>_____ (B)</td> </tr> <tr> <td colspan="2" style="text-align: center;">Prevalence Index = B/A = _____</td> </tr> </table>	Total % Cover of:	Multiply by:	OBL species _____	x1 = _____	FACW species _____	x2 = _____	FAC species _____	x3 = _____	FACU species _____	x4 = _____	UPL species _____	x5 = _____	Column Totals: _____ (A)	_____ (B)	Prevalence Index = B/A = _____	
Total % Cover of:	Multiply by:																			
OBL species _____	x1 = _____																			
FACW species _____	x2 = _____																			
FAC species _____	x3 = _____																			
FACU species _____	x4 = _____																			
UPL species _____	x5 = _____																			
Column Totals: _____ (A)	_____ (B)																			
Prevalence Index = B/A = _____																				
Sapling/Shrub Stratum (Plot size: 15 foot radius)																				
1. <u>Cytisus scoparius</u>	40	yes	UPL																	
2. <u>Rubus armeniacus</u>	20	yes	FACU																	
3. _____	_____	_____	_____																	
4. _____	_____	_____	_____																	
5. _____	_____	_____	_____																	
50% = 1, 20% = 1	70	= Total Cover																		
Herb Stratum (Plot size: 3 foot radius)																				
1. <u>Agrostis capillaris</u>	60	yes	FAC																	
2. <u>Galium trifidum</u>	1	no	FACW																	
3. <u>Phalaris arundinacea</u>	10	no	FACW																	
4. <u>Tanacetum vulgare</u>	5	no	UPL																	
5. _____	_____	_____	_____																	
6. _____	_____	_____	_____																	
7. _____	_____	_____	_____																	
8. _____	_____	_____	_____																	
9. _____	_____	_____	_____																	
10. _____	_____	_____	_____																	
11. _____	_____	_____	_____																	
50% = 1, 20% = 0	76	= Total Cover																		
Woody Vine Stratum (Plot size: 3 foot radius)																				
1. _____	_____	_____	_____																	
2. _____	_____	_____	_____																	
50% = _____, 20% = _____	0	= Total Cover																		
% Bare Ground in Herb Stratum <u>24</u>																				

Hydrophytic Vegetation Indicators:

1 – Rapid Test for Hydrophytic Vegetation

2 - Dominance Test is >50%

3 - Prevalence Index is $\leq 3.0^1$

4 - Morphological Adaptations¹ (Provide supporting data in Remarks or on a separate sheet)

5 - Wetland Non-Vascular Plants¹

Problematic Hydrophytic Vegetation¹ (Explain)

¹Indicators of hydric soil and wetland hydrology must be present, unless disturbed or problematic.

Hydrophytic Vegetation Present? Yes No

Remarks: 37% dominant wetland vegetation per the Dominance Test.

SOIL

Profile Description: (Describe to the depth needed to document the indicator or confirm the absence of indicators.)

Depth (inches)	Matrix		Redox Features				Texture	Remarks
	Color (moist)	%	Color (moist)	%	Type ¹	Loc ²		
0 to 4	10YR 5/4	70	10YR 4/2	30	D	M	Sandy loam	w/gravel
4 to 10	10YR 4/3	75	10YR 4/2	25	D	M	Sandy loam	w/gravel
10 to 18+	10YR 4/3	25	10YR 4/2	25	D	M	Sandy loam	w/gravel
_____	_____	_____	_____	_____	_____	_____	_____	_____
_____	_____	_____	_____	_____	_____	_____	_____	_____
_____	_____	_____	_____	_____	_____	_____	_____	_____
_____	_____	_____	_____	_____	_____	_____	_____	_____
_____	_____	_____	_____	_____	_____	_____	_____	_____

¹Type: C= Concentration, D=Depletion, RM=Reduced Matrix, CS=Covered or Coated Sand Grains. ²Location: PL=Pore Lining, M=Matrix

Hydric Soil Indicators: (Applicable to all LRRs, unless otherwise noted.)

- Histosol (A1) Sandy Redox (S5)
- Histic Epipedon (A2) Stripped Matrix (S6)
- Black Histic (A3) Loamy Mucky Mineral (F1) **(except MLRA 1)**
- Hydrogen Sulfide (A4) Loamy Gleyed Matrix (F2)
- Depleted Below Dark Surface (A11) Depleted Matrix (F3)
- Thick Dark Surface (A12) Redox Dark Surface (F6)
- Sandy Mucky Mineral (S1) Depleted Dark Surface (F7)
- Sandy Gleyed Matrix (S4) Redox Depressions (F8)

Indicators for Problematic Hydric Soils³:

- 2 cm Muck (A10)
- Red Parent Material (TF2)
- Very Shallow Dark Surface (TF12)
- Other (Explain in Remarks)

³Indicators of hydrophytic vegetation and wetland hydrology must be present, unless disturbed or problematic.

Restrictive Layer (if present):

Type: _____
 Depth (inches): _____

Hydric Soils Present? Yes No

Remarks: 3 and 4 chroma with redox features

HYDROLOGY

Wetland Hydrology Indicators:

Primary Indicators (minimum of one required; check all that apply)

- Surface Water (A1) Water-Stained Leaves (B9)
- High Water Table (A2) **(except MLRA 1, 2, 4A, and 4B)**
- Saturation (A3) Salt Crust (B11)
- Water Marks (B1) Aquatic Invertebrates (B13)
- Sediment Deposits (B2) Hydrogen Sulfide Odor (C1)
- Drift Deposits (B3) Oxidized Rhizospheres along Living Roots (C3)
- Algal Mat or Crust (B4) Presence of Reduced Iron (C4)
- Iron Deposits (B5) Recent Iron Reduction in Tilled Soils (C6)
- Surface Soil Cracks (B6) Stunted or Stresses Plants (D1) **(LRR A)**
- Inundation Visible on Aerial Imagery (B7) Other (Explain in Remarks)
- Sparsely Vegetated Concave Surface (B8)

Secondary Indicators (2 or more required)

- Water-Stained Leaves (B9) **(MLRA 1, 2, 4A, and 4B)**
- Drainage Patterns (B10)
- Dry-Season Water Table (C2)
- Saturation Visible on Aerial Imagery (C9)
- Geomorphic Position (D2)
- Shallow Aquitard (D3)
- FAC-Neutral Test (D5)
- Raised Ant Mounds (D6) **(LRR A)**
- Frost-Heave Hummocks (D7)

Field Observations:

Surface Water Present? Yes No Depth (inches): _____
 Water Table Present? Yes No Depth (inches): _____
 Saturation Present? (includes capillary fringe) Yes No Depth (inches): _____

Wetland Hydrology Present? Yes No

Describe Recorded Data (stream gauge, monitoring well, aerial photos, previous inspections), if available:

Remarks: No saturation or water table observed in sample plot

WETLAND DETERMINATION DATA FORM – Western Mountains, Valleys, and Coast Region

Project Site: Sound Transit East Link Extension Project City/County: Bellevue/King Sampling Date: April 23, 2013
 Applicant/Owner: Sound Transit State: WA Sampling Point: BNSF West SP3W
 Investigator(s): C Douglas & J. Pursley Section, Township, Range: S29, T24N, R5E
 Landform (hillslope, terrace, etc.): Area adjacent to RR Tracks Local relief (concave, convex, none): concave Slope (%): 0% to 2%
 Subregion (LRR): A Lat: 47.62N Long: 122.18W Datum: _____
 Soil Map Unit Name: Alderwood gravelly sandy loam & Kitsap silt loam NWI classification: None Mapped
 Are climatic / hydrologic conditions on the site typical for this time of year? Yes No (If no, explain in Remarks.)
 Are Vegetation , Soil , or Hydrology , significantly disturbed? Are "Normal Circumstances" present? Yes No
 Are Vegetation , Soil , or Hydrology , naturally problematic? (If needed, explain any answers in Remarks.)

SUMMARY OF FINDINGS – Attach site map showing sampling point locations, transects, important features, etc.

Hydrophytic Vegetation Present?	Yes <input checked="" type="checkbox"/>	No <input type="checkbox"/>	Is the Sampled Area within a Wetland?	Yes <input checked="" type="checkbox"/>	No <input type="checkbox"/>
Hydric Soil Present?	Yes <input checked="" type="checkbox"/>	No <input type="checkbox"/>		Yes <input checked="" type="checkbox"/>	No <input type="checkbox"/>
Wetland Hydrology Present?	Yes <input checked="" type="checkbox"/>	No <input type="checkbox"/>			
Remarks: Wetland BNSF West is located adjacent to railroad tracks with commercial development located to the west. Wetland includes depressional and slope HGM classes. Jurisdictional ditch along railroad tracks hydrologically connects wetland to wetlands to the north and south.					

VEGETATION – Use scientific names of plants

Tree Stratum (Plot size: 30 foot radius)	Absolute % Cover	Dominant Species?	Indicator Status	Dominance Test Worksheet:
1. <u>Salix scouleriana</u>	95	yes	FAC	Number of Dominant Species That Are OBL, FACW, or FAC: <u>5</u> (A) Total Number of Dominant Species Across All Strata: <u>5</u> (B) Percent of Dominant Species That Are OBL, FACW, or FAC: <u>100</u> (A/B)
2. _____	_____	_____	_____	
3. _____	_____	_____	_____	
4. _____	_____	_____	_____	
50% = <u>1</u> , 20% = <u>0</u>	95	= Total Cover		
Sapling/Shrub Stratum (Plot size: 15 foot radius)	Absolute % Cover	Dominant Species?	Indicator Status	Prevalence Index worksheet:
1. <u>Spiraea douglasii</u>	40	yes	FACW	Total % Cover of: _____ Multiply by: _____ OBL species _____ x1 = _____ FACW species _____ x2 = _____ FAC species _____ x3 = _____ FACU species _____ x4 = _____ UPL species _____ x5 = _____ Column Totals: _____ (A) _____ (B) Prevalence Index = B/A = _____
2. _____	_____	_____	_____	
3. _____	_____	_____	_____	
4. _____	_____	_____	_____	
5. _____	_____	_____	_____	
50% = <u>1</u> , 20% = <u>0</u>	40	= Total Cover		
Herb Stratum (Plot size: 3 foot radius)	Absolute % Cover	Dominant Species?	Indicator Status	Hydrophytic Vegetation Indicators:
1. <u>Equisetum arvense</u>	10	yes	FAC	<input type="checkbox"/> 1 – Rapid Test for Hydrophytic Vegetation <input checked="" type="checkbox"/> 2 - Dominance Test is >50% <input type="checkbox"/> 3 - Prevalence Index is ≤3.0 ¹ <input type="checkbox"/> 4 - Morphological Adaptations ¹ (Provide supporting data in Remarks or on a separate sheet) <input type="checkbox"/> 5 - Wetland Non-Vascular Plants ¹ <input type="checkbox"/> Problematic Hydrophytic Vegetation ¹ (Explain) ¹ Indicators of hydric soil and wetland hydrology must be present, unless disturbed or problematic.
2. <u>Phalaris arundinacea</u>	30	yes	FACW	
3. <u>Tolmiea menziesii</u>	10	yes	FAC	
4. _____	_____	_____	_____	
5. _____	_____	_____	_____	
6. _____	_____	_____	_____	
7. _____	_____	_____	_____	
8. _____	_____	_____	_____	
9. _____	_____	_____	_____	
10. _____	_____	_____	_____	
11. _____	_____	_____	_____	
50% = <u>1</u> , 20% = <u>2</u>	50	= Total Cover		
Woody Vine Stratum (Plot size: 3 foot radius)	Absolute % Cover	Dominant Species?	Indicator Status	Hydrophytic Vegetation Present?
1. _____	_____	_____	_____	Yes <input checked="" type="checkbox"/> No <input type="checkbox"/>
2. _____	_____	_____	_____	
50% = _____, 20% = _____	0	= Total Cover		
% Bare Ground in Herb Stratum <u>50</u>				

Remarks: 100% dominant wetland vegetation per the Dominance Test

SOIL

Profile Description: (Describe to the depth needed to document the indicator or confirm the absence of indicators.)

Depth (inches)	Matrix		Redox Features				Texture	Remarks
	Color (moist)	%	Color (moist)	%	Type ¹	Loc ²		
0 to 3	10YR 4/1	100	None	None	None	None	Silt loam	
3 to 6	10YR 4/1	100	None	None	None	None	Silt loam	w/gravel
6 to 18+	10YR 4/1	100	None	None	None	None	Silt loam	w/gravel & cobble
_____	_____	_____	_____	_____	_____	_____	_____	_____
_____	_____	_____	_____	_____	_____	_____	_____	_____
_____	_____	_____	_____	_____	_____	_____	_____	_____
_____	_____	_____	_____	_____	_____	_____	_____	_____

¹Type: C= Concentration, D=Depletion, RM=Reduced Matrix, CS=Covered or Coated Sand Grains. ²Location: PL=Pore Lining, M=Matrix

Hydric Soil Indicators: (Applicable to all LRRs, unless otherwise noted.)		Indicators for Problematic Hydric Soils³:
<input type="checkbox"/> Histosol (A1)	<input type="checkbox"/> Sandy Redox (S5)	<input type="checkbox"/> 2 cm Muck (A10)
<input type="checkbox"/> Histic Epipedon (A2)	<input type="checkbox"/> Stripped Matrix (S6)	<input type="checkbox"/> Red Parent Material (TF2)
<input type="checkbox"/> Black Histic (A3)	<input type="checkbox"/> Loamy Mucky Mineral (F1) (except MLRA 1)	<input type="checkbox"/> Very Shallow Dark Surface (TF12)
<input type="checkbox"/> Hydrogen Sulfide (A4)	<input type="checkbox"/> Loamy Gleyed Matrix (F2)	<input type="checkbox"/> Other (Explain in Remarks)
<input type="checkbox"/> Depleted Below Dark Surface (A11)	<input type="checkbox"/> Depleted Matrix (F3)	
<input checked="" type="checkbox"/> Thick Dark Surface (A12)	<input type="checkbox"/> Redox Dark Surface (F6)	
<input type="checkbox"/> Sandy Mucky Mineral (S1)	<input type="checkbox"/> Depleted Dark Surface (F7)	
<input type="checkbox"/> Sandy Gleyed Matrix (S4)	<input type="checkbox"/> Redox Depressions (F8)	

³Indicators of hydrophytic vegetation and wetland hydrology must be present, unless disturbed or problematic.

Restrictive Layer (if present): Type: _____ Depth (inches): _____	Hydric Soils Present? Yes <input checked="" type="checkbox"/> No <input type="checkbox"/>
--	--

Remarks: 1 chroma

HYDROLOGY

Wetland Hydrology Indicators:	
Primary Indicators (minimum of one required; check all that apply)	Secondary Indicators (2 or more required)
<input type="checkbox"/> Surface Water (A1)	<input checked="" type="checkbox"/> Water-Stained Leaves (B9)
<input checked="" type="checkbox"/> High Water Table (A2)	(except MLRA 1, 2, 4A, and 4B)
<input checked="" type="checkbox"/> Saturation (A3)	<input type="checkbox"/> Salt Crust (B11)
<input type="checkbox"/> Water Marks (B1)	<input type="checkbox"/> Aquatic Invertebrates (B13)
<input type="checkbox"/> Sediment Deposits (B2)	<input type="checkbox"/> Hydrogen Sulfide Odor (C1)
<input type="checkbox"/> Drift Deposits (B3)	<input type="checkbox"/> Oxidized Rhizospheres along Living Roots (C3)
<input type="checkbox"/> Algal Mat or Crust (B4)	<input type="checkbox"/> Presence of Reduced Iron (C4)
<input type="checkbox"/> Iron Deposits (B5)	<input type="checkbox"/> Recent Iron Reduction in Tilled Soils (C6)
<input type="checkbox"/> Surface Soil Cracks (B6)	<input type="checkbox"/> Stunted or Stresses Plants (D1) (LRR A)
<input type="checkbox"/> Inundation Visible on Aerial Imagery (B7)	<input type="checkbox"/> Other (Explain in Remarks)
<input type="checkbox"/> Sparsely Vegetated Concave Surface (B8)	<input type="checkbox"/> Water-Stained Leaves (B9)
	(MLRA 1, 2, 4A, and 4B)
	<input type="checkbox"/> Drainage Patterns (B10)
	<input type="checkbox"/> Dry-Season Water Table (C2)
	<input type="checkbox"/> Saturation Visible on Aerial Imagery (C9)
	<input type="checkbox"/> Geomorphic Position (D2)
	<input type="checkbox"/> Shallow Aquitard (D3)
	<input type="checkbox"/> FAC-Neutral Test (D5)
	<input type="checkbox"/> Raised Ant Mounds (D6) (LRR A)
	<input type="checkbox"/> Frost-Heave Hummocks (D7)

Field Observations:	Wetland Hydrology Present? Yes <input checked="" type="checkbox"/> No <input type="checkbox"/>
Surface Water Present? Yes <input type="checkbox"/> No <input checked="" type="checkbox"/> Depth (inches): _____	
Water Table Present? Yes <input checked="" type="checkbox"/> No <input type="checkbox"/> Depth (inches): <u>2 inches</u>	
Saturation Present? (includes capillary fringe) Yes <input checked="" type="checkbox"/> No <input type="checkbox"/> Depth (inches): <u>Surface</u>	

Describe Recorded Data (stream gauge, monitoring well, aerial photos, previous inspections), if available:

Remarks: Saturation and water table observed in sample plot

WETLAND DETERMINATION DATA FORM – Western Mountains, Valleys, and Coast Region

Project Site: Sound Transit East Link Extension Project City/County: Bellevue/King Sampling Date: April 23, 2013
 Applicant/Owner: Sound Transit State: WA Sampling Point: BNSF West SP4U
 Investigator(s): C Douglas & J. Pursley Section, Township, Range: S29, T24N, R5E
 Landform (hillslope, terrace, etc.): Area adjacent to RR Tracks Local relief (concave, convex, none): concave Slope (%): 0% to 2%
 Subregion (LRR): A Lat: 47.62N Long: 122.18W Datum: _____
 Soil Map Unit Name: Alderwood gravelly sandy loam & Kitsap silt loam NWI classification: None Mapped
 Are climatic / hydrologic conditions on the site typical for this time of year? Yes No (If no, explain in Remarks.)
 Are Vegetation , Soil , or Hydrology , significantly disturbed? Are "Normal Circumstances" present? Yes No
 Are Vegetation , Soil , or Hydrology , naturally problematic? (If needed, explain any answers in Remarks.)

SUMMARY OF FINDINGS – Attach site map showing sampling point locations, transects, important features, etc.

Hydrophytic Vegetation Present?	Yes <input type="checkbox"/>	No <input checked="" type="checkbox"/>	Is the Sampled Area within a Wetland?	Yes <input type="checkbox"/>	No <input checked="" type="checkbox"/>
Hydric Soil Present?	Yes <input type="checkbox"/>	No <input checked="" type="checkbox"/>		Yes <input type="checkbox"/>	No <input checked="" type="checkbox"/>
Wetland Hydrology Present?	Yes <input type="checkbox"/>	No <input checked="" type="checkbox"/>		Yes <input type="checkbox"/>	No <input checked="" type="checkbox"/>
Remarks: Wetland BNSF West is located adjacent to railroad tracks with commercial development located to the west. Wetland includes depressional and slope HGM classes. Jurisdictional ditch along railroad tracks hydrologically connects wetland to wetlands to the north and south.					

VEGETATION – Use scientific names of plants

Tree Stratum (Plot size: 30 foot radius)	Absolute % Cover	Dominant Species?	Indicator Status	Dominance Test Worksheet:
1. _____	_____	_____	_____	Number of Dominant Species That Are OBL, FACW, or FAC: <u>2</u> (A) Total Number of Dominant Species Across All Strata: <u>5</u> (B) Percent of Dominant Species That Are OBL, FACW, or FAC: <u>40</u> (A/B)
2. _____	_____	_____	_____	
3. _____	_____	_____	_____	
4. _____	_____	_____	_____	
50% = <u>0</u> , 20% = <u>0</u>	<u>0</u>	= Total Cover		
Sapling/Shrub Stratum (Plot size: 15 foot radius)				Prevalence Index worksheet: Total % Cover of: _____ Multiply by: OBL species _____ x1 = _____ FACW species _____ x2 = _____ FAC species _____ x3 = _____ FACU species _____ x4 = _____ UPL species _____ x5 = _____ Column Totals: _____ (A) _____ (B) Prevalence Index = B/A = _____
1. <u><i>Ilex aquifolium</i></u>	<u>20</u>	<u>yes</u>	<u>FACU</u>	
2. <u><i>Oemleria cerasiformis</i></u>	<u>15</u>	<u>yes</u>	<u>FACU</u>	
3. <u><i>Rubus armeniacus</i></u>	<u>10</u>	<u>no</u>	<u>FACU</u>	
4. _____	_____	_____	_____	
5. _____	_____	_____	_____	
50% = <u>0</u> , 20% = <u>2</u>	<u>45</u>	= Total Cover		
Herb Stratum (Plot size: 3 foot radius)				Hydrophytic Vegetation Indicators: <input type="checkbox"/> 1 – Rapid Test for Hydrophytic Vegetation <input checked="" type="checkbox"/> 2 - Dominance Test is >50% <input type="checkbox"/> 3 - Prevalence Index is $\leq 3.0^1$ <input type="checkbox"/> 4 - Morphological Adaptations ¹ (Provide supporting data in Remarks or on a separate sheet) <input type="checkbox"/> 5 - Wetland Non-Vascular Plants ¹ <input type="checkbox"/> Problematic Hydrophytic Vegetation ¹ (Explain) ¹ Indicators of hydric soil and wetland hydrology must be present, unless disturbed or problematic.
1. <u><i>Agrostis capillaris</i></u>	<u>10</u>	<u>no</u>	<u>FAC</u>	
2. <u><i>Cirsium arvense</i></u>	<u>30</u>	<u>yes</u>	<u>FACU</u>	
3. <u><i>Equisetum arvense</i></u>	<u>35</u>	<u>yes</u>	<u>FAC</u>	
4. <u><i>Festuca rubra</i></u>	<u>15</u>	<u>yes</u>	<u>FAC</u>	
5. _____	_____	_____	_____	
6. _____	_____	_____	_____	
7. _____	_____	_____	_____	
8. _____	_____	_____	_____	
9. _____	_____	_____	_____	
10. _____	_____	_____	_____	
11. _____	_____	_____	_____	
50% = <u>0</u> , 20% = <u>3</u>	<u>90</u>	= Total Cover		
Woody Vine Stratum (Plot size: 3 foot radius)				Hydrophytic Vegetation Present? Yes <input type="checkbox"/> No <input checked="" type="checkbox"/>
1. _____	_____	_____	_____	
2. _____	_____	_____	_____	
50% = _____, 20% = _____	<u>0</u>	= Total Cover		
% Bare Ground in Herb Stratum <u>10</u>				

Remarks: 40% dominant wetland vegetation per the Dominance Test.

SOIL

Profile Description: (Describe to the depth needed to document the indicator or confirm the absence of indicators.)

Depth (inches)	Matrix		Redox Features				Texture	Remarks
	Color (moist)	%	Color (moist)	%	Type ¹	Loc ²		
0 to 18+	10YR 4/2	100	None	None	None	None	Sandy loam	w/gravel & angular rock
_____	_____	_____	_____	_____	_____	_____	_____	_____
_____	_____	_____	_____	_____	_____	_____	_____	_____
_____	_____	_____	_____	_____	_____	_____	_____	_____
_____	_____	_____	_____	_____	_____	_____	_____	_____
_____	_____	_____	_____	_____	_____	_____	_____	_____

¹Type: C= Concentration, D=Depletion, RM=Reduced Matrix, CS=Covered or Coated Sand Grains. ²Location: PL=Pore Lining, M=Matrix

Hydric Soil Indicators: (Applicable to all LRRs, unless otherwise noted.)

- Histosol (A1)
- Histic Epipedon (A2)
- Black Histic (A3)
- Hydrogen Sulfide (A4)
- Depleted Below Dark Surface (A11)
- Thick Dark Surface (A12)
- Sandy Mucky Mineral (S1)
- Sandy Gleyed Matrix (S4)
- Sandy Redox (S5)
- Stripped Matrix (S6)
- Loamy Mucky Mineral (F1) **(except MLRA 1)**
- Loamy Gleyed Matrix (F2)
- Depleted Matrix (F3)
- Redox Dark Surface (F6)
- Depleted Dark Surface (F7)
- Redox Depressions (F8)

Indicators for Problematic Hydric Soils³:

- 2 cm Muck (A10)
- Red Parent Material (TF2)
- Very Shallow Dark Surface (TF12)
- Other (Explain in Remarks)

³Indicators of hydrophytic vegetation and wetland hydrology must be present, unless disturbed or problematic.

Restrictive Layer (if present):

Type: _____
 Depth (inches): _____

Hydric Soils Present? Yes No

Remarks: 2 chroma with no redox features

HYDROLOGY

Wetland Hydrology Indicators:

Primary Indicators (minimum of one required; check all that apply)

- Surface Water (A1)
- High Water Table (A2)
- Saturation (A3)
- Water Marks (B1)
- Sediment Deposits (B2)
- Drift Deposits (B3)
- Algal Mat or Crust (B4)
- Iron Deposits (B5)
- Surface Soil Cracks (B6)
- Inundation Visible on Aerial Imagery (B7)
- Sparsely Vegetated Concave Surface (B8)
- Water-Stained Leaves (B9) **(except MLRA 1, 2, 4A, and 4B)**
- Salt Crust (B11)
- Aquatic Invertebrates (B13)
- Hydrogen Sulfide Odor (C1)
- Oxidized Rhizospheres along Living Roots (C3)
- Presence of Reduced Iron (C4)
- Recent Iron Reduction in Tilled Soils (C6)
- Stunted or Stresses Plants (D1) **(LRR A)**
- Other (Explain in Remarks)

Secondary Indicators (2 or more required)

- Water-Stained Leaves (B9) **(MLRA 1, 2, 4A, and 4B)**
- Drainage Patterns (B10)
- Dry-Season Water Table (C2)
- Saturation Visible on Aerial Imagery (C9)
- Geomorphic Position (D2)
- Shallow Aquitard (D3)
- FAC-Neutral Test (D5)
- Raised Ant Mounds (D6) **(LRR A)**
- Frost-Heave Hummocks (D7)

Field Observations:

Surface Water Present? Yes No Depth (inches): _____
 Water Table Present? Yes No Depth (inches): _____
 Saturation Present? (includes capillary fringe) Yes No Depth (inches): _____

Wetland Hydrology Present? Yes No

Describe Recorded Data (stream gauge, monitoring well, aerial photos, previous inspections), if available:

Remarks: No saturation or water table observed in sample plot

WETLAND DETERMINATION DATA FORM – Western Mountains, Valleys, and Coast Region

Project Site: Sound Transit East Link Extension Project City/County: Bellevue/King Sampling Date: Feb. 14, 2013
 Applicant/Owner: Sound Transit State: WA Sampling Point: Central Lake SPU
 Investigator(s): C Douglas & J. Pursley Section, Township, Range: S29, T24N, R5E
 Landform (hillslope, terrace, etc.): Narrow area between development Local relief (concave, convex, none): concave Slope (%): 0% to 2%
 Subregion (LRR): A Lat: 47.62N Long: 122.18W Datum: _____
 Soil Map Unit Name: Alderwood gravelly sandy loam NWI classification: None Mapped
 Are climatic / hydrologic conditions on the site typical for this time of year? Yes No (If no, explain in Remarks.)
 Are Vegetation , Soil , or Hydrology , significantly disturbed? Are "Normal Circumstances" present? Yes No
 Are Vegetation , Soil , or Hydrology , naturally problematic? (If needed, explain any answers in Remarks.)

SUMMARY OF FINDINGS – Attach site map showing sampling point locations, transects, important features, etc.

Hydrophytic Vegetation Present?	Yes <input checked="" type="checkbox"/>	No <input type="checkbox"/>	Is the Sampled Area within a Wetland?		
Hydric Soil Present?	Yes <input type="checkbox"/>	No <input checked="" type="checkbox"/>		Yes <input type="checkbox"/>	No <input checked="" type="checkbox"/>
Wetland Hydrology Present?	Yes <input type="checkbox"/>	No <input checked="" type="checkbox"/>			
Remarks: Wetland D is located in narrow area between railroad tracks and development on Lake Bellevue. Wetland includes depressional HGM class.					

VEGETATION – Use scientific names of plants

Tree Stratum (Plot size: 30 foot radius)	Absolute % Cover	Dominant Species?	Indicator Status	Dominance Test Worksheet:																
1. _____	_____	_____	_____	Number of Dominant Species That Are OBL, FACW, or FAC: 1 (A) Total Number of Dominant Species Across All Strata: 2 (B) Percent of Dominant Species That Are OBL, FACW, or FAC: 50 (A/B)																
2. _____	_____	_____	_____																	
3. _____	_____	_____	_____																	
4. _____	_____	_____	_____																	
50% = 0, 20% = 0	0	= Total Cover		Prevalence Index worksheet: <table style="width: 100%; border: none;"> <tr> <td style="text-align: center;">Total % Cover of:</td> <td style="text-align: center;">Multiply by:</td> </tr> <tr> <td>OBL species _____</td> <td>x1 = _____</td> </tr> <tr> <td>FACW species _____</td> <td>x2 = _____</td> </tr> <tr> <td>FAC species _____</td> <td>x3 = _____</td> </tr> <tr> <td>FACU species _____</td> <td>x4 = _____</td> </tr> <tr> <td>UPL species _____</td> <td>x5 = _____</td> </tr> <tr> <td>Column Totals: _____ (A)</td> <td>_____ (B)</td> </tr> <tr> <td colspan="2" style="text-align: center;">Prevalence Index = B/A = _____</td> </tr> </table>	Total % Cover of:	Multiply by:	OBL species _____	x1 = _____	FACW species _____	x2 = _____	FAC species _____	x3 = _____	FACU species _____	x4 = _____	UPL species _____	x5 = _____	Column Totals: _____ (A)	_____ (B)	Prevalence Index = B/A = _____	
Total % Cover of:	Multiply by:																			
OBL species _____	x1 = _____																			
FACW species _____	x2 = _____																			
FAC species _____	x3 = _____																			
FACU species _____	x4 = _____																			
UPL species _____	x5 = _____																			
Column Totals: _____ (A)	_____ (B)																			
Prevalence Index = B/A = _____																				
Sapling/Shrub Stratum (Plot size: 15 foot radius)																				
1. <u>Rubus armeniacus</u>	10	yes	FACU																	
2. _____	_____	_____	_____																	
3. _____	_____	_____	_____																	
4. _____	_____	_____	_____																	
5. _____	_____	_____	_____																	
50% = 1, 20% = 0	10	= Total Cover																		
Herb Stratum (Plot size: 3 foot radius)																				
1. <u>Epilobium watsonii</u>	10	yes	FACW																	
2. <u>Verbascum thapsus</u>	1	no	UPL																	
3. _____	_____	_____	_____																	
4. _____	_____	_____	_____																	
5. _____	_____	_____	_____																	
6. _____	_____	_____	_____																	
7. _____	_____	_____	_____																	
8. _____	_____	_____	_____																	
9. _____	_____	_____	_____																	
10. _____	_____	_____	_____																	
11. _____	_____	_____	_____																	
50% = 1, 20% = 0	11	= Total Cover																		
Woody Vine Stratum (Plot size: 3 foot radius)																				
1. _____	_____	_____	_____																	
2. _____	_____	_____	_____																	
50% = _____, 20% = _____	0	= Total Cover																		
% Bare Ground in Herb Stratum <u>89</u>																				

Hydrophytic Vegetation Indicators:

1 – Rapid Test for Hydrophytic Vegetation

2 - Dominance Test is >50%

3 - Prevalence Index is $\leq 3.0^1$

4 - Morphological Adaptations¹ (Provide supporting data in Remarks or on a separate sheet)

5 - Wetland Non-Vascular Plants¹

Problematic Hydrophytic Vegetation¹ (Explain)

¹Indicators of hydric soil and wetland hydrology must be present, unless disturbed or problematic.

Hydrophytic Vegetation Present? Yes No

Remarks: 50% dominant wetland vegetation per the Dominance Test, only 2 dominant species.

SOIL

Profile Description: (Describe to the depth needed to document the indicator or confirm the absence of indicators.)

Depth (inches)	Matrix		Redox Features				Texture	Remarks
	Color (moist)	%	Color (moist)	%	Type ¹	Loc ²		
0 to 18+	None	None	None	None	None	None	Sand	Fill prism gravel & angular rock
_____	_____	_____	_____	_____	_____	_____	_____	_____
_____	_____	_____	_____	_____	_____	_____	_____	_____
_____	_____	_____	_____	_____	_____	_____	_____	_____
_____	_____	_____	_____	_____	_____	_____	_____	_____
_____	_____	_____	_____	_____	_____	_____	_____	_____
_____	_____	_____	_____	_____	_____	_____	_____	_____

¹Type: C= Concentration, D=Depletion, RM=Reduced Matrix, CS=Covered or Coated Sand Grains. ²Location: PL=Pore Lining, M=Matrix

Hydric Soil Indicators: (Applicable to all LRRs, unless otherwise noted.)

- | | |
|--|--|
| <input type="checkbox"/> Histosol (A1) | <input type="checkbox"/> Sandy Redox (S5) |
| <input type="checkbox"/> Histic Epipedon (A2) | <input type="checkbox"/> Stripped Matrix (S6) |
| <input type="checkbox"/> Black Histic (A3) | <input type="checkbox"/> Loamy Mucky Mineral (F1) (except MLRA 1) |
| <input type="checkbox"/> Hydrogen Sulfide (A4) | <input type="checkbox"/> Loamy Gleyed Matrix (F2) |
| <input type="checkbox"/> Depleted Below Dark Surface (A11) | <input type="checkbox"/> Depleted Matrix (F3) |
| <input type="checkbox"/> Thick Dark Surface (A12) | <input type="checkbox"/> Redox Dark Surface (F6) |
| <input type="checkbox"/> Sandy Mucky Mineral (S1) | <input type="checkbox"/> Depleted Dark Surface (F7) |
| <input type="checkbox"/> Sandy Gleyed Matrix (S4) | <input type="checkbox"/> Redox Depressions (F8) |

Indicators for Problematic Hydric Soils³:

- | |
|---|
| <input type="checkbox"/> 2 cm Muck (A10) |
| <input type="checkbox"/> Red Parent Material (TF2) |
| <input type="checkbox"/> Very Shallow Dark Surface (TF12) |
| <input type="checkbox"/> Other (Explain in Remarks) |

³Indicators of hydrophytic vegetation and wetland hydrology must be present, unless disturbed or problematic.

Restrictive Layer (if present):

Type: Fill prism
 Depth (inches): At surface

Hydric Soils Present? Yes No

Remarks: Fill prism of sand, gravel, and angular rock

HYDROLOGY

Wetland Hydrology Indicators:

Primary Indicators (minimum of one required; check all that apply)

- | | |
|--|---|
| <input type="checkbox"/> Surface Water (A1) | <input type="checkbox"/> Water-Stained Leaves (B9) |
| <input type="checkbox"/> High Water Table (A2) | (except MLRA 1, 2, 4A, and 4B) |
| <input type="checkbox"/> Saturation (A3) | <input type="checkbox"/> Salt Crust (B11) |
| <input type="checkbox"/> Water Marks (B1) | <input type="checkbox"/> Aquatic Invertebrates (B13) |
| <input type="checkbox"/> Sediment Deposits (B2) | <input type="checkbox"/> Hydrogen Sulfide Odor (C1) |
| <input type="checkbox"/> Drift Deposits (B3) | <input type="checkbox"/> Oxidized Rhizospheres along Living Roots (C3) |
| <input type="checkbox"/> Algal Mat or Crust (B4) | <input type="checkbox"/> Presence of Reduced Iron (C4) |
| <input type="checkbox"/> Iron Deposits (B5) | <input type="checkbox"/> Recent Iron Reduction in Tilled Soils (C6) |
| <input type="checkbox"/> Surface Soil Cracks (B6) | <input type="checkbox"/> Stunted or Stresses Plants (D1) (LRR A) |
| <input type="checkbox"/> Inundation Visible on Aerial Imagery (B7) | <input type="checkbox"/> Other (Explain in Remarks) |
| <input type="checkbox"/> Sparsely Vegetated Concave Surface (B8) | |

Secondary Indicators (2 or more required)

- | |
|--|
| <input type="checkbox"/> Water-Stained Leaves (B9) |
| (MLRA 1, 2, 4A, and 4B) |
| <input type="checkbox"/> Drainage Patterns (B10) |
| <input type="checkbox"/> Dry-Season Water Table (C2) |
| <input type="checkbox"/> Saturation Visible on Aerial Imagery (C9) |
| <input type="checkbox"/> Geomorphic Position (D2) |
| <input type="checkbox"/> Shallow Aquitard (D3) |
| <input type="checkbox"/> FAC-Neutral Test (D5) |
| <input type="checkbox"/> Raised Ant Mounds (D6) (LRR A) |
| <input type="checkbox"/> Frost-Heave Hummocks (D7) |

Field Observations:

Surface Water Present? Yes No Depth (inches): _____
 Water Table Present? Yes No Depth (inches): _____
 Saturation Present? Yes No Depth (inches): _____
 (includes capillary fringe)

Wetland Hydrology Present? Yes No

Describe Recorded Data (stream gauge, monitoring well, aerial photos, previous inspections), if available:

Remarks: No saturation or water table observed in sample plot

WETLAND DETERMINATION DATA FORM – Western Mountains, Valleys, and Coast Region

Project Site: Sound Transit East Link Extension Project City/County: Bellevue/King Sampling Date: Feb. 14, 2013
 Applicant/Owner: Sound Transit State: WA Sampling Point: Central Lake SPW
 Investigator(s): C Douglas & J. Pursley Section, Township, Range: S29, T24N, R5E
 Landform (hillslope, terrace, etc.): Narrow area between development Local relief (concave, convex, none): concave Slope (%): 0% to 2%
 Subregion (LRR): A Lat: 47.62N Long: 122.18W Datum: _____
 Soil Map Unit Name: Alderwood gravelly sandy loam NWI classification: None Mapped
 Are climatic / hydrologic conditions on the site typical for this time of year? Yes No (If no, explain in Remarks.)
 Are Vegetation , Soil , or Hydrology , significantly disturbed? Are "Normal Circumstances" present? Yes No
 Are Vegetation , Soil , or Hydrology , naturally problematic? (If needed, explain any answers in Remarks.)

SUMMARY OF FINDINGS – Attach site map showing sampling point locations, transects, important features, etc.

Hydrophytic Vegetation Present?	Yes <input checked="" type="checkbox"/>	No <input type="checkbox"/>	Is the Sampled Area within a Wetland?	Yes <input checked="" type="checkbox"/>	No <input type="checkbox"/>
Hydric Soil Present?	Yes <input checked="" type="checkbox"/>	No <input type="checkbox"/>		Yes <input checked="" type="checkbox"/>	No <input type="checkbox"/>
Wetland Hydrology Present?	Yes <input checked="" type="checkbox"/>	No <input type="checkbox"/>			
Remarks: Wetland Central Lake is located in narrow area between railroad tracks and development on Lake Bellevue. Wetland includes depressional HGM class.					

VEGETATION – Use scientific names of plants

Tree Stratum (Plot size: 30 foot radius)	Absolute % Cover	Dominant Species?	Indicator Status	Dominance Test Worksheet:																
1. <u><i>Alnus rubra</i></u>	5	yes	FAC	Number of Dominant Species That Are OBL, FACW, or FAC: <u>5</u> (A) Total Number of Dominant Species Across All Strata: <u>6</u> (B) Percent of Dominant Species That Are OBL, FACW, or FAC: <u>83</u> (A/B)																
2. _____	_____	_____	_____																	
3. _____	_____	_____	_____																	
4. _____	_____	_____	_____																	
50% = 1, 20% = 0	5	= Total Cover		Prevalence Index worksheet: <table style="width: 100%; border: none;"> <tr> <td style="text-align: right;">Total % Cover of:</td> <td style="text-align: left;">Multiply by:</td> </tr> <tr> <td>OBL species _____</td> <td>x1 = _____</td> </tr> <tr> <td>FACW species _____</td> <td>x2 = _____</td> </tr> <tr> <td>FAC species _____</td> <td>x3 = _____</td> </tr> <tr> <td>FACU species _____</td> <td>x4 = _____</td> </tr> <tr> <td>UPL species _____</td> <td>x5 = _____</td> </tr> <tr> <td>Column Totals: _____ (A)</td> <td>_____ (B)</td> </tr> <tr> <td colspan="2" style="text-align: center;">Prevalence Index = B/A = _____</td> </tr> </table>	Total % Cover of:	Multiply by:	OBL species _____	x1 = _____	FACW species _____	x2 = _____	FAC species _____	x3 = _____	FACU species _____	x4 = _____	UPL species _____	x5 = _____	Column Totals: _____ (A)	_____ (B)	Prevalence Index = B/A = _____	
Total % Cover of:	Multiply by:																			
OBL species _____	x1 = _____																			
FACW species _____	x2 = _____																			
FAC species _____	x3 = _____																			
FACU species _____	x4 = _____																			
UPL species _____	x5 = _____																			
Column Totals: _____ (A)	_____ (B)																			
Prevalence Index = B/A = _____																				
<u>Sapling/Shrub Stratum (Plot size: 15 foot radius)</u>																				
1. <u><i>Cornus sericea</i></u>	1	no	FACW																	
2. <u><i>Rubus armeniacus</i></u>	20	yes	FACU																	
3. <u><i>Spiraea douglasii</i></u>	50	yes	FACW																	
4. _____	_____	_____	_____																	
5. _____	_____	_____	_____																	
50% = 1, 20% = 1	71	= Total Cover																		
<u>Herb Stratum (Plot size: 3 foot radius)</u>																				
1. <u><i>Epilobium watsonii</i></u>	20	yes	FACW	Hydrophytic Vegetation Indicators: <input type="checkbox"/> 1 – Rapid Test for Hydrophytic Vegetation <input checked="" type="checkbox"/> 2 - Dominance Test is >50% <input type="checkbox"/> 3 - Prevalence Index is $\leq 3.0^1$ <input type="checkbox"/> 4 - Morphological Adaptations ¹ (Provide supporting data in Remarks or on a separate sheet) <input type="checkbox"/> 5 - Wetland Non-Vascular Plants ¹ <input type="checkbox"/> Problematic Hydrophytic Vegetation ¹ (Explain) ¹ Indicators of hydric soil and wetland hydrology must be present, unless disturbed or problematic.																
2. <u><i>Ludwigia palustris</i></u>	60	yes	OBL																	
3. <u><i>Phalaris arundinacea</i></u>	20	yes	FACW																	
4. _____	_____	_____	_____																	
5. _____	_____	_____	_____																	
6. _____	_____	_____	_____																	
7. _____	_____	_____	_____																	
8. _____	_____	_____	_____																	
9. _____	_____	_____	_____																	
10. _____	_____	_____	_____																	
11. _____	_____	_____	_____																	
50% = 1, 20% = 2	100	= Total Cover																		
<u>Woody Vine Stratum (Plot size: 3 foot radius)</u>																				
1. _____	_____	_____	_____	Hydrophytic Vegetation Present?																
2. _____	_____	_____	_____		Yes <input checked="" type="checkbox"/> No <input type="checkbox"/>															
50% = _____, 20% = _____	0	= Total Cover																		
% Bare Ground in Herb Stratum <u>0</u>																				

Remarks: 83% dominant wetland vegetation per the Dominance Test

SOIL

Profile Description: (Describe to the depth needed to document the indicator or confirm the absence of indicators.)								
Depth (inches)	Matrix		Redox Features				Texture	Remarks
	Color (moist)	%	Color (moist)	%	Type ¹	Loc ²		
0 to 3	<u>10YR 3/1</u>	<u>100</u>	<u>None</u>	<u>None</u>	<u>None</u>	<u>None</u>	<u>Silt loam</u>	<u>w/organic material</u>
3 to 8	<u>10YR 5/2</u>	<u>60</u>	<u>10YR 5/6</u>	<u>40</u>	<u>D</u>	<u>M</u>	<u>Sandy loam</u>	<u>w/gravel</u>
8 to 18+	<u>Gley 1.5/5G</u>	<u>100</u>	<u>None</u>	<u>None</u>	<u>None</u>	<u>None</u>	<u>Sandy clay</u>	<u>w/gravel & angular rock</u>
_____	_____	_____	_____	_____	_____	_____	_____	_____
_____	_____	_____	_____	_____	_____	_____	_____	_____
_____	_____	_____	_____	_____	_____	_____	_____	_____
_____	_____	_____	_____	_____	_____	_____	_____	_____
¹ Type: C= Concentration, D=Depletion, RM=Reduced Matrix, CS=Covered or Coated Sand Grains. ² Location: PL=Pore Lining, M=Matrix								
Hydric Soil Indicators: (Applicable to all LRRs, unless otherwise noted.)						Indicators for Problematic Hydric Soils³:		
<input type="checkbox"/> Histosol (A1)			<input checked="" type="checkbox"/> Sandy Redox (S5)			<input type="checkbox"/> 2 cm Muck (A10)		
<input type="checkbox"/> Histic Epipedon (A2)			<input type="checkbox"/> Stripped Matrix (S6)			<input type="checkbox"/> Red Parent Material (TF2)		
<input type="checkbox"/> Black Histic (A3)			<input type="checkbox"/> Loamy Mucky Mineral (F1) (except MLRA 1)			<input type="checkbox"/> Very Shallow Dark Surface (TF12)		
<input type="checkbox"/> Hydrogen Sulfide (A4)			<input type="checkbox"/> Loamy Gleyed Matrix (F2)			<input type="checkbox"/> Other (Explain in Remarks)		
<input type="checkbox"/> Depleted Below Dark Surface (A11)			<input type="checkbox"/> Depleted Matrix (F3)			³ Indicators of hydrophytic vegetation and wetland hydrology must be present, unless disturbed or problematic.		
<input checked="" type="checkbox"/> Thick Dark Surface (A12)			<input type="checkbox"/> Redox Dark Surface (F6)					
<input type="checkbox"/> Sandy Mucky Mineral (S1)			<input type="checkbox"/> Depleted Dark Surface (F7)					
<input checked="" type="checkbox"/> Sandy Gleyed Matrix (S4)			<input type="checkbox"/> Redox Depressions (F8)					
Restrictive Layer (if present):					Hydric Soils Present?			
Type: _____					Yes <input checked="" type="checkbox"/> No <input type="checkbox"/>			
Depth (inches): _____								
Remarks: 1 and 2 chroma with redox and gley soils								

HYDROLOGY

Wetland Hydrology Indicators:			
Primary Indicators (minimum of one required; check all that apply)		Secondary Indicators (2 or more required)	
<input type="checkbox"/> Surface Water (A1)	<input checked="" type="checkbox"/> Water-Stained Leaves (B9)	<input type="checkbox"/> Water-Stained Leaves (B9)	
<input checked="" type="checkbox"/> High Water Table (A2)	(except MLRA 1, 2, 4A, and 4B)	(MLRA 1, 2, 4A, and 4B)	
<input checked="" type="checkbox"/> Saturation (A3)	<input type="checkbox"/> Salt Crust (B11)	<input type="checkbox"/> Drainage Patterns (B10)	
<input type="checkbox"/> Water Marks (B1)	<input type="checkbox"/> Aquatic Invertebrates (B13)	<input type="checkbox"/> Dry-Season Water Table (C2)	
<input type="checkbox"/> Sediment Deposits (B2)	<input type="checkbox"/> Hydrogen Sulfide Odor (C1)	<input type="checkbox"/> Saturation Visible on Aerial Imagery (C9)	
<input type="checkbox"/> Drift Deposits (B3)	<input type="checkbox"/> Oxidized Rhizospheres along Living Roots (C3)	<input type="checkbox"/> Geomorphic Position (D2)	
<input type="checkbox"/> Algal Mat or Crust (B4)	<input type="checkbox"/> Presence of Reduced Iron (C4)	<input type="checkbox"/> Shallow Aquitard (D3)	
<input type="checkbox"/> Iron Deposits (B5)	<input type="checkbox"/> Recent Iron Reduction in Tilled Soils (C6)	<input type="checkbox"/> FAC-Neutral Test (D5)	
<input type="checkbox"/> Surface Soil Cracks (B6)	<input type="checkbox"/> Stunted or Stresses Plants (D1) (LRR A)	<input type="checkbox"/> Raised Ant Mounds (D6) (LRR A)	
<input type="checkbox"/> Inundation Visible on Aerial Imagery (B7)	<input type="checkbox"/> Other (Explain in Remarks)	<input type="checkbox"/> Frost-Heave Hummocks (D7)	
<input type="checkbox"/> Sparsely Vegetated Concave Surface (B8)			
Field Observations:		Wetland Hydrology Present?	
Surface Water Present? Yes <input type="checkbox"/> No <input checked="" type="checkbox"/>	Depth (inches): _____	Yes <input checked="" type="checkbox"/> No <input type="checkbox"/>	
Water Table Present? Yes <input checked="" type="checkbox"/> No <input type="checkbox"/>	Depth (inches): <u>5 inches</u>		
Saturation Present? (includes capillary fringe) Yes <input checked="" type="checkbox"/> No <input type="checkbox"/>	Depth (inches): <u>Surface</u>		
Describe Recorded Data (stream gauge, monitoring well, aerial photos, previous inspections), if available:			
Remarks: Saturation and water table observed in sample plot			

Wetland name or number Kelsey West Tributary Pond

WETLAND RATING FORM – WESTERN WASHINGTON
Version 2 – Updated July 2006 to increase accuracy and reproducibility among users
Updated Oct. 2008 with the new WDFW definitions for priority habitats

Name of wetland (if known): Kelsey West Tributary Pond Date of site visit: 8/2/2011

Rated by: M. Maynard Trained by Ecology? Yes X No Date of training: 04/2006

SEC: 28 TWNSHP: 25N RNGE: 5E Is S/T/R in Appendix D? Yes No X

Map of wetland unit: Figure Estimated size 4.8 acres

SUMMARY OF RATING

Category based on FUNCTIONS provided by wetland: I II X III IV

Category I =	Score > 70
Category II =	Score 51 - 69
Category III =	Score 30 – 50
Category IV =	Score < 30

Score for Water Quality Functions	22
Score for Hydrologic Functions	24
Score for Habitat Functions	17
TOTAL Score for Functions	63

Category based on SPECIAL CHARACTERISTICS of Wetland I II Does not apply X

Final Category (choose the “highest” category from above”) II

Summary of basic information about the wetland unit.

Wetland Unit has Special Characteristics	Wetland HGM Class used for Rating
Estuarine	X
Natural Heritage Wetland	
Bog	
Mature Forest	
Old Growth Forest	
Coastal Lagoon	
Interdunal	
None of the above	
	Check if unit has multiple HGM classes present

Does the wetland being rated meet any of the criteria below? If you answer YES to any of the questions below you will need to protect the wetland according to the regulations regarding the special characteristics found in the wetland.

Check List for Wetlands that Need Additional Protection (in addition to the protection recommended for its category)	YES	NO
SP1. <i>Has the wetland unit been documented as a habitat for any Federally listed Threatened or Endangered animal or plant species (T/E species)?</i> For the purposes of this rating system, “documented” means the wetland is on the appropriate state or federal database.		X
SP2. <i>Has the wetland unit been documented as habitat for any State listed Threatened or Endangered animal species?</i> For the purposes of this rating system, “documented” means the wetland is on the appropriate state database. Note: Wetlands with State listed plant species are categorized as Category 1 Natural Heritage Wetlands (see p. 19 of data form).		X
SP3. <i>Does the wetland unit contain individuals of Priority species listed by the WDFW for the state?</i>		X
SP4. <i>Does the wetland unit have a local significance in addition to its functions?</i> For example, the wetland has been identified in the Shoreline Master Program, the Critical Areas Ordinance, or in a local management plan as having special significance.		X

To complete the next part of the data sheet you will need to determine the Hydrogeomorphic Class of the wetland being rated.

Classification of Vegetated Wetlands for Western Washington

If the hydrologic criteria listed in each question do not apply to the entire unit being rated, you probably have a unit with multiple HGM classes. In this case, identify which hydrologic criteria in questions 1-7 apply, and go to Question 8.

1. Are the water levels in the entire unit usually controlled by tides (i.e. except during floods)?
NO – go to 2 **YES – the wetland class is Tidal Fringe**
 If yes, is the salinity of the water during periods of annual low flow below 0.5 ppt (parts per thousand)?
YES – Freshwater Tidal Fringe **NO – Saltwater Tidal Fringe (Estuarine)**
If your wetland can be classified as a Freshwater Tidal Fringe use the forms for Riverine wetlands. If it is a Saltwater Tidal Fringe it is rated as an Estuarine wetland. Wetlands that were call estuarine in the first and second editions of the rating system are called Salt Water Tidal Fringe in the Hydrogeomorphic Classification. Estuarine wetlands were categorized separately in the earlier editions, and this separation is being kept in this revision. To maintain consistency between editions, the term “Estuarine” wetland is kept. Please note, however, that the characteristics that define Category I and II estuarine wetlands have changed (see p. _____).

2. The entire wetland unit is flat and precipitation is only source (>90%) of water to it. Groundwater and surface water runoff are NOT sources of water to the unit.
NO – go to 3 **YES – The wetland class is Flats**
 If your wetland can be classified as a “Flats” wetland, use the form for **Depressional** wetlands.

3. Does the entire wetland meet both of the following criteria?
 _____ The vegetated part of the wetland is on the shores of a body of permanent open water (without any vegetation on the surface) where at least 20 acres (8ha) in size;
 _____ At least 30% of the open water area is deeper than 6.6 (2 m)?
NO – go to 4 **YES – The wetland class is Lake-fringe (Lacustrine Fringe)**

4. Does the entire wetland meet all of the following criteria?
 _____ The wetland is on a slope (*slope can be very gradual*).
 _____ The water flows through the wetland in one direction (unidirectional) and usually comes from seeps. It may flow subsurface, as sheetflow, or in a swale without distinct banks.
 _____ The water leaves the wetland **without being impounded**?
 NOTE: *Surface water does not pond in these types of wetlands except occasionally in very small and shallow depressions or behind hummocks (depressions are usually <3 ft diameter and less than 1 foot deep).*
NO – go to 5 **YES – The wetland class is Slope**

5. Does the entire wetland meet all of the following criteria?
 _____ The unit is in a valley or stream channel where it gets inundated by overbank flooding from that stream or river.
 _____ The overbank flooding occurs at least once every two years.
 NOTE: *The riverine unit can contain depressions that are filled with water when the river is not flooding..*
NO – go to 6 **YES – The wetland class is Riverine**

6. Is the entire wetland unit in a topographic depression in which water ponds, or is saturated to the surface, at some time of the year. This means that any outlet, if present is higher than the interior of the wetland.
NO – go to 7 **YES – The wetland class is Depressional**

7. Is the entire wetland located in a very flat area with no obvious depression and no overbank flooding. The unit does not pond surface water more than a few inches. The unit seems to be maintained by high groundwater in the area. The wetland may be ditched, but has no obvious natural outlet.
No – go to 8 **YES – The wetland class is Depressional**

8. Your wetland unit seems to be difficult to classify and probably contains several different HGM classes. For example, seeps at the base of a slope may grade into a riverine floodplain, or a small stream within a depressional wetland has a zone of flooding along its sides. **GO BACK AND IDENTIFY WHICH OF THE HYDROLOGIC REGIMES DESCRIBED IN QUESTIONS 1-7 APPLY TO DIFFERENT AREAS IN THE UNIT** (make a rough sketch to help you decide). Use the following table to identify the appropriate class to use for the rating system if you have several HGM classes present within your wetland. NOTE: Use this table only if the class that is recommended in the second column represents 10% or more of the total area of the wetland unit being rated. If the area of the class listed in column 2 is less than 10% of the unit, classify the wetland using the class that represents more than 90% of the total area.

HGM Classes within the wetland unit being rated	HGM Class to Use in Rating
Slope + Riverine	Riverine
Slope + Depressional	Depressional
Slope + Lake-fringe	Lake-fringe
Depressional + Riverine along stream within boundary	Depressional
Depressional + Lake-fringe	Depressional
Salt Water Tidal Fringe and any other class of freshwater wetland	Treat as ESTUARINE under wetlands with special characteristics

If you are unable still to determine which of the above criteria apply to your wetland, or you have more than 2 HGM classes within a wetland boundary, classify the wetland as **Depressional** for the rating.

WETLAND DETERMINATION DATA FORM – Western Mountains, Valleys, and Coast Region

Project Site: Sound Transit East Link Extension Project City/County: Bellevue/King Sampling Date: Feb. 6, 2013
 Applicant/Owner: Sound Transit State: WA Sampling Point: Kelsey West Tributary Stream SP1W
 Investigator(s): C Douglas & J. Pursley Section, Township, Range: S28, T24N, R5E
 Landform (hillslope, terrace, etc.): Riparian, narrow area between development Local relief (concave, convex, none): concave Slope (%): 0% to 2%
 Subregion (LRR): A Lat: 47.62N Long: 122.18W Datum: _____
 Soil Map Unit Name: Everett gravelly sandy loam NWI classification: None Mapped
 Are climatic / hydrologic conditions on the site typical for this time of year? Yes No (If no, explain in Remarks.)
 Are Vegetation , Soil , or Hydrology , significantly disturbed? Are "Normal Circumstances" present? Yes No
 Are Vegetation , Soil , or Hydrology , naturally problematic? (If needed, explain any answers in Remarks.)

SUMMARY OF FINDINGS – Attach site map showing sampling point locations, transects, important features, etc.

Hydrophytic Vegetation Present?	Yes <input checked="" type="checkbox"/>	No <input type="checkbox"/>	Is the Sampled Area within a Wetland?	Yes <input checked="" type="checkbox"/>	No <input type="checkbox"/>
Hydric Soil Present?	Yes <input checked="" type="checkbox"/>	No <input type="checkbox"/>		Yes <input checked="" type="checkbox"/>	No <input type="checkbox"/>
Wetland Hydrology Present?	Yes <input checked="" type="checkbox"/>	No <input type="checkbox"/>		Yes <input checked="" type="checkbox"/>	No <input type="checkbox"/>
Remarks: Wetland Kelsey West Tributary Stream is associated with the west tributary of Kelsey Creek. The creek flows into a culvert at the downstream end of the stream. Wetland Kelsey West Tributary Stream is located on both the left and right banks of the stream. Wetland located in narrow area between commercial development. Wetland includes riverine HGM class.					

VEGETATION – Use scientific names of plants

Tree Stratum (Plot size: 30 foot radius)	Absolute % Cover	Dominant Species?	Indicator Status	Dominance Test Worksheet:
1. <u>Salix lasiandra</u>	<u>20</u>	<u>yes</u>	<u>FACW</u>	Number of Dominant Species That Are OBL, FACW, or FAC: <u>4</u> (A) Total Number of Dominant Species Across All Strata: <u>4</u> (B) Percent of Dominant Species That Are OBL, FACW, or FAC: <u>100</u> (A/B)
2. _____	_____	_____	_____	
3. _____	_____	_____	_____	
4. _____	_____	_____	_____	
50% = <u>1</u> , 20% = <u>0</u>	<u>20</u>	= Total Cover		
<u>Sapling/Shrub Stratum (Plot size: 15 foot radius)</u>				
1. <u>Cornus sericea</u>	<u>25</u>	<u>yes</u>	<u>FACW</u>	Prevalence Index worksheet: Total % Cover of: _____ Multiply by: OBL species _____ x1 = _____ FACW species _____ x2 = _____ FAC species _____ x3 = _____ FACU species _____ x4 = _____ UPL species _____ x5 = _____ Column Totals: _____ (A) _____ (B) Prevalence Index = B/A = _____
2. <u>Rubus armeniacus</u>	<u>30</u>	<u>no</u>	<u>FACU</u>	
3. <u>Solanum dulcamara</u>	<u>30</u>	<u>yes</u>	<u>FAC</u>	
4. _____	_____	_____	_____	
5. _____	_____	_____	_____	
50% = <u>0</u> , 20% = <u>2</u>	<u>85</u>	= Total Cover		
<u>Herb Stratum (Plot size: 3 foot radius)</u>				
1. <u>Epilobium angustifolium</u>	<u>10</u>	<u>no</u>	<u>FACU</u>	Hydrophytic Vegetation Indicators: <input type="checkbox"/> 1 – Rapid Test for Hydrophytic Vegetation <input checked="" type="checkbox"/> 2 - Dominance Test is >50% <input type="checkbox"/> 3 - Prevalence Index is ≤3.0 ¹ <input type="checkbox"/> 4 - Morphological Adaptations ¹ (Provide supporting data in Remarks or on a separate sheet) <input type="checkbox"/> 5 - Wetland Non-Vascular Plants ¹ <input type="checkbox"/> Problematic Hydrophytic Vegetation ¹ (Explain) ¹ Indicators of hydric soil and wetland hydrology must be present, unless disturbed or problematic.
2. <u>Juncus effusus</u>	<u>15</u>	<u>no</u>	<u>FACW</u>	
3. <u>Phalaris arundinacea</u>	<u>90</u>	<u>yes</u>	<u>FACW</u>	
4. _____	_____	_____	_____	
5. _____	_____	_____	_____	
6. _____	_____	_____	_____	
7. _____	_____	_____	_____	
8. _____	_____	_____	_____	
9. _____	_____	_____	_____	
10. _____	_____	_____	_____	
11. _____	_____	_____	_____	
50% = <u>1</u> , 20% = <u>0</u>	<u>100</u>	= Total Cover		
<u>Woody Vine Stratum (Plot size: 3 foot radius)</u>				
1. _____	_____	_____	_____	Hydrophytic Vegetation Present? Yes <input checked="" type="checkbox"/> No <input type="checkbox"/>
2. _____	_____	_____	_____	
50% = _____, 20% = _____	<u>0</u>	= Total Cover		
% Bare Ground in Herb Stratum <u>0</u>				
Remarks: 100% dominant wetland vegetation per the Dominance Test				

SOIL

Profile Description: (Describe to the depth needed to document the indicator or confirm the absence of indicators.)								
Depth (inches)	Matrix		Redox Features				Texture	Remarks
	Color (moist)	%	Color (moist)	%	Type ¹	Loc ²		
<u>0 to 18+</u>	<u>10YR 3/1</u>	<u>100</u>	<u>None</u>	<u>None</u>	<u>None</u>	<u>None</u>	<u>Silt loam</u>	
_____	_____	_____	_____	_____	_____	_____	_____	
_____	_____	_____	_____	_____	_____	_____	_____	
_____	_____	_____	_____	_____	_____	_____	_____	
_____	_____	_____	_____	_____	_____	_____	_____	
_____	_____	_____	_____	_____	_____	_____	_____	
_____	_____	_____	_____	_____	_____	_____	_____	
_____	_____	_____	_____	_____	_____	_____	_____	
¹ Type: C= Concentration, D=Depletion, RM=Reduced Matrix, CS=Covered or Coated Sand Grains.			² Location: PL=Pore Lining, M=Matrix					
Hydric Soil Indicators: (Applicable to all LRRs, unless otherwise noted.)						Indicators for Problematic Hydric Soils³:		
<input type="checkbox"/> Histosol (A1)			<input type="checkbox"/> Sandy Redox (S5)			<input type="checkbox"/> 2 cm Muck (A10)		
<input type="checkbox"/> Histic Epipedon (A2)			<input type="checkbox"/> Stripped Matrix (S6)			<input type="checkbox"/> Red Parent Material (TF2)		
<input type="checkbox"/> Black Histic (A3)			<input type="checkbox"/> Loamy Mucky Mineral (F1) (except MLRA 1)			<input type="checkbox"/> Very Shallow Dark Surface (TF12)		
<input type="checkbox"/> Hydrogen Sulfide (A4)			<input type="checkbox"/> Loamy Gleyed Matrix (F2)			<input type="checkbox"/> Other (Explain in Remarks)		
<input type="checkbox"/> Depleted Below Dark Surface (A11)			<input type="checkbox"/> Depleted Matrix (F3)			³ Indicators of hydrophytic vegetation and wetland hydrology must be present, unless disturbed or problematic.		
<input checked="" type="checkbox"/> Thick Dark Surface (A12)			<input type="checkbox"/> Redox Dark Surface (F6)					
<input type="checkbox"/> Sandy Mucky Mineral (S1)			<input type="checkbox"/> Depleted Dark Surface (F7)					
<input type="checkbox"/> Sandy Gleyed Matrix (S4)			<input type="checkbox"/> Redox Depressions (F8)					
Restrictive Layer (if present):								
Type: _____								
Depth (inches): _____					Hydric Soils Present? Yes <input checked="" type="checkbox"/> No <input type="checkbox"/>			
Remarks: 1 chroma								

HYDROLOGY

Wetland Hydrology Indicators:			
Primary Indicators (minimum of one required; check all that apply)		Secondary Indicators (2 or more required)	
<input type="checkbox"/> Surface Water (A1)	<input checked="" type="checkbox"/> Water-Stained Leaves (B9)	<input type="checkbox"/> Water-Stained Leaves (B9)	
<input checked="" type="checkbox"/> High Water Table (A2)	(except MLRA 1, 2, 4A, and 4B)	(MLRA 1, 2, 4A, and 4B)	
<input checked="" type="checkbox"/> Saturation (A3)	<input type="checkbox"/> Salt Crust (B11)	<input type="checkbox"/> Drainage Patterns (B10)	
<input checked="" type="checkbox"/> Water Marks (B1)	<input type="checkbox"/> Aquatic Invertebrates (B13)	<input type="checkbox"/> Dry-Season Water Table (C2)	
<input type="checkbox"/> Sediment Deposits (B2)	<input type="checkbox"/> Hydrogen Sulfide Odor (C1)	<input type="checkbox"/> Saturation Visible on Aerial Imagery (C9)	
<input type="checkbox"/> Drift Deposits (B3)	<input type="checkbox"/> Oxidized Rhizospheres along Living Roots (C3)	<input type="checkbox"/> Geomorphic Position (D2)	
<input type="checkbox"/> Algal Mat or Crust (B4)	<input type="checkbox"/> Presence of Reduced Iron (C4)	<input type="checkbox"/> Shallow Aquitard (D3)	
<input type="checkbox"/> Iron Deposits (B5)	<input type="checkbox"/> Recent Iron Reduction in Tilled Soils (C6)	<input type="checkbox"/> FAC-Neutral Test (D5)	
<input type="checkbox"/> Surface Soil Cracks (B6)	<input type="checkbox"/> Stunted or Stresses Plants (D1) (LRR A)	<input type="checkbox"/> Raised Ant Mounds (D6) (LRR A)	
<input type="checkbox"/> Inundation Visible on Aerial Imagery (B7)	<input type="checkbox"/> Other (Explain in Remarks)	<input type="checkbox"/> Frost-Heave Hummocks (D7)	
<input type="checkbox"/> Sparsely Vegetated Concave Surface (B8)			
Field Observations:			
Surface Water Present? Yes <input type="checkbox"/> No <input checked="" type="checkbox"/>	Depth (inches): _____	Wetland Hydrology Present? Yes <input checked="" type="checkbox"/> No <input type="checkbox"/>	
Water Table Present? Yes <input checked="" type="checkbox"/> No <input type="checkbox"/>	Depth (inches): <u>5 inches</u>		
Saturation Present? (includes capillary fringe) Yes <input checked="" type="checkbox"/> No <input type="checkbox"/>	Depth (inches): <u>Surface</u>		
Describe Recorded Data (stream gauge, monitoring well, aerial photos, previous inspections), if available:			
Remarks: Saturation and water table observed in sample plot			

WETLAND DETERMINATION DATA FORM – Western Mountains, Valleys, and Coast Region

Project Site: Sound Transit East Link Extension Project City/County: Bellevue/King Sampling Date: Feb. 6, 2013
 Applicant/Owner: Sound Transit State: WA Sampling Point: Kelsey West Tributary Stream SP2U
 Investigator(s): C Douglas & J. Pursley Section, Township, Range: S28, T24N, R5E
 Landform (hillslope, terrace, etc.): Riparian, narrow area between development Local relief (concave, convex, none): concave Slope (%): 0% to 2%
 Subregion (LRR): A Lat: 47.62N Long: 122.18W Datum: _____
 Soil Map Unit Name: Everett gravelly sandy loam NWI classification: None Mapped
 Are climatic / hydrologic conditions on the site typical for this time of year? Yes No (If no, explain in Remarks.)
 Are Vegetation , Soil , or Hydrology , significantly disturbed? Are "Normal Circumstances" present? Yes No
 Are Vegetation , Soil , or Hydrology , naturally problematic? (If needed, explain any answers in Remarks.)

SUMMARY OF FINDINGS – Attach site map showing sampling point locations, transects, important features, etc.

Hydrophytic Vegetation Present?	Yes <input checked="" type="checkbox"/>	No <input type="checkbox"/>	Is the Sampled Area within a Wetland?	Yes <input type="checkbox"/>	No <input checked="" type="checkbox"/>
Hydric Soil Present?	Yes <input type="checkbox"/>	No <input checked="" type="checkbox"/>		Yes <input type="checkbox"/>	No <input checked="" type="checkbox"/>
Wetland Hydrology Present?	Yes <input type="checkbox"/>	No <input checked="" type="checkbox"/>		Yes <input type="checkbox"/>	No <input checked="" type="checkbox"/>
Remarks: Wetland Kelsey West Tributary Stream is associated with the west Tributary of Kelsey Creek. The creek flows into a culvert at the downstream end of the stream. Wetland Kelsey West Tributary Stream is located on both the left and right banks of the stream. Wetland located in narrow area between commercial development. Wetland includes riverine HGM class.					

VEGETATION – Use scientific names of plants

Tree Stratum (Plot size: 30 foot radius)	Absolute % Cover	Dominant Species?	Indicator Status	Dominance Test Worksheet:		
1. _____	_____	_____	_____	Number of Dominant Species That Are OBL, FACW, or FAC: <u>2</u> (A) Total Number of Dominant Species Across All Strata: <u>3</u> (B) Percent of Dominant Species That Are OBL, FACW, or FAC: <u>67</u> (A/B)		
2. _____	_____	_____	_____			
3. _____	_____	_____	_____			
4. _____	_____	_____	_____			
50% = <u>0</u> , 20% = <u>0</u>	<u>0</u>	= Total Cover		Prevalence Index worksheet: Total % Cover of: _____ Multiply by: OBL species _____ x1 = _____ FACW species _____ x2 = _____ FAC species _____ x3 = _____ FACU species _____ x4 = _____ UPL species _____ x5 = _____ Column Totals: _____ (A) _____ (B) Prevalence Index = B/A = _____		
<u>Sapling/Shrub Stratum (Plot size: 15 foot radius)</u>						
1. <u>Polygonum cuspidatum</u>	<u>20</u>	<u>no</u>	<u>FACU</u>			
2. <u>Rubus armeniacus</u>	<u>90</u>	<u>yes</u>	<u>FACU</u>			
3. <u>Solanum dulcamara</u>	<u>30</u>	<u>yes</u>	<u>FAC</u>			
4. _____	_____	_____	_____			
5. _____	_____	_____	_____			
50% = <u>1</u> , 20% = <u>1</u>	<u>100</u>	= Total Cover				
<u>Herb Stratum (Plot size: 3 foot radius)</u>				Hydrophytic Vegetation Indicators: <input type="checkbox"/> 1 – Rapid Test for Hydrophytic Vegetation <input type="checkbox"/> 2 - Dominance Test is >50% <input type="checkbox"/> 3 - Prevalence Index is ≤3.0 ¹ <input type="checkbox"/> 4 - Morphological Adaptations ¹ (Provide supporting data in Remarks or on a separate sheet) <input type="checkbox"/> 5 - Wetland Non-Vascular Plants ¹ <input type="checkbox"/> Problematic Hydrophytic Vegetation ¹ (Explain) ¹ Indicators of hydric soil and wetland hydrology must be present, unless disturbed or problematic.		
1. <u>Agrostis capillaris</u>	<u>30</u>	<u>yes</u>	<u>FAC</u>			
2. _____	_____	_____	_____			
3. _____	_____	_____	_____			
4. _____	_____	_____	_____			
5. _____	_____	_____	_____			
6. _____	_____	_____	_____			
7. _____	_____	_____	_____			
8. _____	_____	_____	_____			
9. _____	_____	_____	_____			
10. _____	_____	_____	_____			
11. _____	_____	_____	_____			
50% = <u>1</u> , 20% = <u>0</u>	<u>30</u>	= Total Cover				
<u>Woody Vine Stratum (Plot size: 3 foot radius)</u>						
1. _____	_____	_____	_____			
2. _____	_____	_____	_____			
50% = _____, 20% = _____	<u>0</u>	= Total Cover				
% Bare Ground in Herb Stratum <u>40</u>						
<table border="0" style="width: 100%;"> <tr> <td style="width: 35%;">Hydrophytic Vegetation Present?</td> <td style="width: 10%;">Yes <input checked="" type="checkbox"/></td> <td style="width: 10%;">No <input type="checkbox"/></td> </tr> </table>				Hydrophytic Vegetation Present?	Yes <input checked="" type="checkbox"/>	No <input type="checkbox"/>
Hydrophytic Vegetation Present?	Yes <input checked="" type="checkbox"/>	No <input type="checkbox"/>				
Remarks: 67% dominant wetland vegetation per the Dominance Test						

SOIL

Profile Description: (Describe to the depth needed to document the indicator or confirm the absence of indicators.)

Table with columns: Depth (inches), Matrix (Color (moist), %), Redox Features (Color (moist), %, Type1, Loc2), Texture, Remarks. Row 1: 0 to 18+, 10YR 2/2, 100, None, None, None, None, Sandy loam, w/cobble, gravel, & angular rock.

1Type: C= Concentration, D=Depletion, RM=Reduced Matrix, CS=Covered or Coated Sand Grains. 2Location: PL=Pore Lining, M=Matrix

Hydric Soil Indicators: (Applicable to all LRRs, unless otherwise noted.)

Indicators for Problematic Hydric Soils3:

- Checkboxes for Hydric Soil Indicators (A1-A12, S1-S4, F1-F8) and Indicators for Problematic Hydric Soils (A10, TF2, TF12, Other).

3Indicators of hydrophytic vegetation and wetland hydrology must be present, unless disturbed or problematic.

Restrictive Layer (if present):

Type: _____
Depth (inches): _____

Hydric Soils Present? Yes [] No [x]

Remarks: 2 chroma with no redox features

HYDROLOGY

Wetland Hydrology Indicators:

Primary Indicators (minimum of one required; check all that apply)

Secondary Indicators (2 or more required)

- Checkboxes for Primary Indicators (A1-A8, B9, C1-C6, D1, E8) and Secondary Indicators (B9, C1-C9, D2-D7).

Field Observations:

Surface Water Present? Yes [] No [x] Depth (inches): _____
Water Table Present? Yes [] No [x] Depth (inches): _____
Saturation Present? (includes capillary fringe) Yes [] No [x] Depth (inches): _____

Wetland Hydrology Present? Yes [] No [x]

Describe Recorded Data (stream gauge, monitoring well, aerial photos, previous inspections), if available:

Remarks: No saturation or water table observed in sample plot

WETLAND DETERMINATION DATA FORM – Western Mountains, Valleys, and Coast Region

Project Site: Sound Transit East Link Extension Project City/County: Bellevue/King Sampling Date: Feb. 6, 2013
 Applicant/Owner: Sound Transit State: WA Sampling Point: Kelsey West Tributary Stream SP3W
 Investigator(s): C Douglas & J. Pursley Section, Township, Range: S28, T24N, R5E
 Landform (hillslope, terrace, etc.): Riparian, narrow area between development Local relief (concave, convex, none): concave Slope (%): 0% to 2%
 Subregion (LRR): A Lat: 47.62N Long: 122.18W Datum: _____
 Soil Map Unit Name: Everett gravelly sandy loam NWI classification: None Mapped
 Are climatic / hydrologic conditions on the site typical for this time of year? Yes No (If no, explain in Remarks.)
 Are Vegetation , Soil , or Hydrology , significantly disturbed? Are "Normal Circumstances" present? Yes No
 Are Vegetation , Soil , or Hydrology , naturally problematic? (If needed, explain any answers in Remarks.)

SUMMARY OF FINDINGS – Attach site map showing sampling point locations, transects, important features, etc.

Hydrophytic Vegetation Present?	Yes <input checked="" type="checkbox"/>	No <input type="checkbox"/>	Is the Sampled Area within a Wetland?	Yes <input checked="" type="checkbox"/>	No <input type="checkbox"/>
Hydric Soil Present?	Yes <input checked="" type="checkbox"/>	No <input type="checkbox"/>		Yes <input checked="" type="checkbox"/>	No <input type="checkbox"/>
Wetland Hydrology Present?	Yes <input checked="" type="checkbox"/>	No <input type="checkbox"/>		Yes <input checked="" type="checkbox"/>	No <input type="checkbox"/>

Remarks: Wetland Kelsey West Tributary Stream is associated with the west tributary of Kelsey Creek. The creek flows into a culvert at the downstream end of the stream. Wetland Kelsey West Tributary Stream is located on both the left and right banks of the stream. Wetland located in narrow area between commercial development. Wetland includes riverine HGM class.

VEGETATION – Use scientific names of plants

Tree Stratum (Plot size: 30 foot radius)	Absolute % Cover	Dominant Species?	Indicator Status	Dominance Test Worksheet:
1. <u>Salix lasiandra</u>	<u>30</u>	<u>yes</u>	<u>FACW</u>	Number of Dominant Species That Are OBL, FACW, or FAC: <u>3</u> (A) Total Number of Dominant Species Across All Strata: <u>4</u> (B) Percent of Dominant Species That Are OBL, FACW, or FAC: <u>75</u> (A/B)
2. _____	_____	_____	_____	
3. _____	_____	_____	_____	
4. _____	_____	_____	_____	
50% = <u>1</u> , 20% = <u>0</u>	<u>30</u>	= Total Cover		
<u>Sapling/Shrub Stratum (Plot size: 15 foot radius)</u>				
1. <u>Oemleria cerasiformis</u>	<u>15</u>	<u>yes</u>	<u>FACU</u>	Prevalence Index worksheet: Total % Cover of: _____ Multiply by: OBL species _____ x1 = _____ FACW species _____ x2 = _____ FAC species _____ x3 = _____ FACU species _____ x4 = _____ UPL species _____ x5 = _____ Column Totals: _____ (A) _____ (B) Prevalence Index = B/A = _____
2. <u>Solanum dulcamara</u>	<u>20</u>	<u>yes</u>	<u>FAC</u>	
3. _____	_____	_____	_____	
4. _____	_____	_____	_____	
5. _____	_____	_____	_____	
50% = <u>1</u> , 20% = <u>1</u>	<u>35</u>	= Total Cover		
<u>Herb Stratum (Plot size: 3 foot radius)</u>				
1. <u>Phalaris arundinacea</u>	<u>90</u>	<u>yes</u>	<u>FACW</u>	Hydrophytic Vegetation Indicators: <input type="checkbox"/> 1 – Rapid Test for Hydrophytic Vegetation <input checked="" type="checkbox"/> 2 - Dominance Test is >50% <input type="checkbox"/> 3 - Prevalence Index is ≤3.0 ¹ <input type="checkbox"/> 4 - Morphological Adaptations ¹ (Provide supporting data in Remarks or on a separate sheet) <input type="checkbox"/> 5 - Wetland Non-Vascular Plants ¹ <input type="checkbox"/> Problematic Hydrophytic Vegetation ¹ (Explain) ¹ Indicators of hydric soil and wetland hydrology must be present, unless disturbed or problematic.
2. <u>Stachys cooleyae</u>	<u>5</u>	<u>no</u>	<u>OBL</u>	
3. _____	_____	_____	_____	
4. _____	_____	_____	_____	
5. _____	_____	_____	_____	
6. _____	_____	_____	_____	
7. _____	_____	_____	_____	
8. _____	_____	_____	_____	
9. _____	_____	_____	_____	
10. _____	_____	_____	_____	
11. _____	_____	_____	_____	
50% = <u>1</u> , 20% = <u>0</u>	<u>95</u>	= Total Cover		
<u>Woody Vine Stratum (Plot size: 3 foot radius)</u>				
1. _____	_____	_____	_____	Hydrophytic Vegetation Present? Yes <input checked="" type="checkbox"/> No <input type="checkbox"/>
2. _____	_____	_____	_____	
50% = _____, 20% = _____	<u>0</u>	= Total Cover		
% Bare Ground in Herb Stratum <u>5</u>				

Remarks: 75% dominant wetland vegetation per the Dominance Test

SOIL

Profile Description: (Describe to the depth needed to document the indicator or confirm the absence of indicators.)								
Depth (inches)	Matrix		Redox Features				Texture	Remarks
	Color (moist)	%	Color (moist)	%	Type ¹	Loc ²		
0 to 18+	10YR 3/1	100	None	None	None	None	Silt loam	
_____	_____	_____	_____	_____	_____	_____	_____	_____
_____	_____	_____	_____	_____	_____	_____	_____	_____
_____	_____	_____	_____	_____	_____	_____	_____	_____
_____	_____	_____	_____	_____	_____	_____	_____	_____
_____	_____	_____	_____	_____	_____	_____	_____	_____

¹Type: C= Concentration, D=Depletion, RM=Reduced Matrix, CS=Covered or Coated Sand Grains. ²Location: PL=Pore Lining, M=Matrix

Hydric Soil Indicators: (Applicable to all LRRs, unless otherwise noted.)		Indicators for Problematic Hydric Soils ³ :	
<input type="checkbox"/> Histosol (A1)	<input type="checkbox"/> Sandy Redox (S5)	<input type="checkbox"/> 2 cm Muck (A10)	
<input type="checkbox"/> Histic Epipedon (A2)	<input type="checkbox"/> Stripped Matrix (S6)	<input type="checkbox"/> Red Parent Material (TF2)	
<input type="checkbox"/> Black Histic (A3)	<input type="checkbox"/> Loamy Mucky Mineral (F1) (except MLRA 1)	<input type="checkbox"/> Very Shallow Dark Surface (TF12)	
<input type="checkbox"/> Hydrogen Sulfide (A4)	<input type="checkbox"/> Loamy Gleyed Matrix (F2)	<input type="checkbox"/> Other (Explain in Remarks)	
<input type="checkbox"/> Depleted Below Dark Surface (A11)	<input type="checkbox"/> Depleted Matrix (F3)		
<input checked="" type="checkbox"/> Thick Dark Surface (A12)	<input type="checkbox"/> Redox Dark Surface (F6)		
<input type="checkbox"/> Sandy Mucky Mineral (S1)	<input type="checkbox"/> Depleted Dark Surface (F7)		
<input type="checkbox"/> Sandy Gleyed Matrix (S4)	<input type="checkbox"/> Redox Depressions (F8)		

³Indicators of hydrophytic vegetation and wetland hydrology must be present, unless disturbed or problematic.

Restrictive Layer (if present): Type: _____ Depth (inches): _____	Hydric Soils Present? Yes <input checked="" type="checkbox"/> No <input type="checkbox"/>
--	--

Remarks: 1 chroma

HYDROLOGY

Wetland Hydrology Indicators:	
Primary Indicators (minimum of one required; check all that apply)	Secondary Indicators (2 or more required)
<input type="checkbox"/> Surface Water (A1)	<input checked="" type="checkbox"/> Water-Stained Leaves (B9)
<input checked="" type="checkbox"/> High Water Table (A2)	(except MLRA 1, 2, 4A, and 4B)
<input checked="" type="checkbox"/> Saturation (A3)	<input type="checkbox"/> Salt Crust (B11)
<input checked="" type="checkbox"/> Water Marks (B1)	<input type="checkbox"/> Aquatic Invertebrates (B13)
<input type="checkbox"/> Sediment Deposits (B2)	<input type="checkbox"/> Hydrogen Sulfide Odor (C1)
<input type="checkbox"/> Drift Deposits (B3)	<input type="checkbox"/> Oxidized Rhizospheres along Living Roots (C3)
<input type="checkbox"/> Algal Mat or Crust (B4)	<input type="checkbox"/> Presence of Reduced Iron (C4)
<input type="checkbox"/> Iron Deposits (B5)	<input type="checkbox"/> Recent Iron Reduction in Tilled Soils (C6)
<input type="checkbox"/> Surface Soil Cracks (B6)	<input type="checkbox"/> Stunted or Stresses Plants (D1) (LRR A)
<input type="checkbox"/> Inundation Visible on Aerial Imagery (B7)	<input type="checkbox"/> Other (Explain in Remarks)
<input type="checkbox"/> Sparsely Vegetated Concave Surface (B8)	

Field Observations: Surface Water Present? Yes <input type="checkbox"/> No <input checked="" type="checkbox"/> Depth (inches): _____ Water Table Present? Yes <input checked="" type="checkbox"/> No <input type="checkbox"/> Depth (inches): <u>5 inches</u> Saturation Present? (includes capillary fringe) Yes <input checked="" type="checkbox"/> No <input type="checkbox"/> Depth (inches): <u>Surface</u>	Wetland Hydrology Present? Yes <input checked="" type="checkbox"/> No <input type="checkbox"/>
---	---

Describe Recorded Data (stream gauge, monitoring well, aerial photos, previous inspections), if available:

Remarks: Saturation and water table observed in sample plot

WETLAND DETERMINATION DATA FORM – Western Mountains, Valleys, and Coast Region

Project Site: Sound Transit East Link Extension Project City/County: Bellevue/King Sampling Date: Feb. 6, 2013
 Applicant/Owner: Sound Transit State: WA Sampling Point: Kelsey West Tributary Stream SP4U
 Investigator(s): C Douglas & J. Pursley Section, Township, Range: S28, T24N, R5E
 Landform (hillslope, terrace, etc.): Riparian, narrow area between development Local relief (concave, convex, none): concave Slope (%): 0% to 2%
 Subregion (LRR): A Lat: 47.62N Long: 122.18W Datum: _____
 Soil Map Unit Name: Everett gravelly sandy loam NWI classification: None Mapped
 Are climatic / hydrologic conditions on the site typical for this time of year? Yes No (If no, explain in Remarks.)
 Are Vegetation , Soil , or Hydrology , significantly disturbed? Are "Normal Circumstances" present? Yes No
 Are Vegetation , Soil , or Hydrology , naturally problematic? (If needed, explain any answers in Remarks.)

SUMMARY OF FINDINGS – Attach site map showing sampling point locations, transects, important features, etc.

Hydrophytic Vegetation Present?	Yes <input checked="" type="checkbox"/>	No <input type="checkbox"/>	Is the Sampled Area within a Wetland?	Yes <input type="checkbox"/>	No <input checked="" type="checkbox"/>
Hydric Soil Present?	Yes <input type="checkbox"/>	No <input checked="" type="checkbox"/>		Yes <input type="checkbox"/>	No <input checked="" type="checkbox"/>
Wetland Hydrology Present?	Yes <input type="checkbox"/>	No <input checked="" type="checkbox"/>		Yes <input type="checkbox"/>	No <input checked="" type="checkbox"/>
Remarks: Wetland Kelsey West Tributary Stream is associated with the west tributary of Kelsey Creek. The creek flows into a culvert at the downstream end of the stream. Wetland Kelsey West Tributary Stream is located on both the left and right banks of the stream. Wetland located in narrow area between commercial development. Wetland includes riverine HGM class.					

VEGETATION – Use scientific names of plants

Tree Stratum (Plot size: 30 foot radius)	Absolute % Cover	Dominant Species?	Indicator Status	Dominance Test Worksheet:																
1. <u>Populus trichocarpa</u>	<u>40</u>	<u>yes</u>	<u>FAC</u>	Number of Dominant Species That Are OBL, FACW, or FAC: <u>1</u> (A) Total Number of Dominant Species Across All Strata: <u>2</u> (B) Percent of Dominant Species That Are OBL, FACW, or FAC: <u>50</u> (A/B)																
2. _____	_____	_____	_____																	
3. _____	_____	_____	_____																	
4. _____	_____	_____	_____																	
50% = <u>1</u> , 20% = <u>0</u>	<u>40</u>	= Total Cover																		
<u>Sapling/Shrub Stratum (Plot size: 15 foot radius)</u>																				
1. <u>Rubus armeniacus</u>	<u>80</u>	<u>yes</u>	<u>FACU</u>	Prevalence Index worksheet: <table style="width: 100%; border: none;"> <tr> <td style="text-align: right;">Total % Cover of:</td> <td style="text-align: left;">Multiply by:</td> </tr> <tr> <td>OBL species _____</td> <td>x1 = _____</td> </tr> <tr> <td>FACW species _____</td> <td>x2 = _____</td> </tr> <tr> <td>FAC species _____</td> <td>x3 = _____</td> </tr> <tr> <td>FACU species _____</td> <td>x4 = _____</td> </tr> <tr> <td>UPL species _____</td> <td>x5 = _____</td> </tr> <tr> <td>Column Totals: _____ (A)</td> <td>_____ (B)</td> </tr> <tr> <td colspan="2" style="text-align: center;">Prevalence Index = B/A = _____</td> </tr> </table>	Total % Cover of:	Multiply by:	OBL species _____	x1 = _____	FACW species _____	x2 = _____	FAC species _____	x3 = _____	FACU species _____	x4 = _____	UPL species _____	x5 = _____	Column Totals: _____ (A)	_____ (B)	Prevalence Index = B/A = _____	
Total % Cover of:	Multiply by:																			
OBL species _____	x1 = _____																			
FACW species _____	x2 = _____																			
FAC species _____	x3 = _____																			
FACU species _____	x4 = _____																			
UPL species _____	x5 = _____																			
Column Totals: _____ (A)	_____ (B)																			
Prevalence Index = B/A = _____																				
2. _____	_____	_____	_____																	
3. _____	_____	_____	_____																	
4. _____	_____	_____	_____																	
5. _____	_____	_____	_____																	
50% = <u>1</u> , 20% = <u>0</u>	<u>80</u>	= Total Cover																		
<u>Herb Stratum (Plot size: 3 foot radius)</u>																				
1. _____	_____	_____	_____	Hydrophytic Vegetation Indicators: <input type="checkbox"/> 1 – Rapid Test for Hydrophytic Vegetation <input type="checkbox"/> 2 - Dominance Test is >50% <input type="checkbox"/> 3 - Prevalence Index is $\leq 3.0^1$ <input type="checkbox"/> 4 - Morphological Adaptations ¹ (Provide supporting data in Remarks or on a separate sheet) <input type="checkbox"/> 5 - Wetland Non-Vascular Plants ¹ <input type="checkbox"/> Problematic Hydrophytic Vegetation ¹ (Explain) ¹ Indicators of hydric soil and wetland hydrology must be present, unless disturbed or problematic.																
2. _____	_____	_____	_____																	
3. _____	_____	_____	_____																	
4. _____	_____	_____	_____																	
5. _____	_____	_____	_____																	
6. _____	_____	_____	_____																	
7. _____	_____	_____	_____																	
8. _____	_____	_____	_____																	
9. _____	_____	_____	_____																	
10. _____	_____	_____	_____																	
11. _____	_____	_____	_____																	
50% = <u>1</u> , 20% = <u>0</u>	<u>0</u>	= Total Cover																		
<u>Woody Vine Stratum (Plot size: 3 foot radius)</u>																				
1. _____	_____	_____	_____	Hydrophytic Vegetation Present? <table style="width: 100%; border: none;"> <tr> <td style="text-align: center;">Yes</td> <td style="text-align: center;"><input checked="" type="checkbox"/></td> <td style="text-align: center;">No</td> <td style="text-align: center;"><input type="checkbox"/></td> </tr> </table>	Yes	<input checked="" type="checkbox"/>	No	<input type="checkbox"/>												
Yes	<input checked="" type="checkbox"/>	No	<input type="checkbox"/>																	
2. _____	_____	_____	_____																	
50% = _____, 20% = _____	<u>0</u>	= Total Cover																		
% Bare Ground in Herb Stratum <u>100</u>																				
Remarks: 50% dominant wetland vegetation per the Dominance Test																				

SOIL

Profile Description: (Describe to the depth needed to document the indicator or confirm the absence of indicators.)

Depth (inches)	Matrix		Redox Features				Texture	Remarks
	Color (moist)	%	Color (moist)	%	Type ¹	Loc ²		
0 to 18+	10YR 2/2	100	None	None	None	None	Sandy loam	w/cobble, gravel, & angular rock
_____	_____	_____	_____	_____	_____	_____	_____	_____
_____	_____	_____	_____	_____	_____	_____	_____	_____
_____	_____	_____	_____	_____	_____	_____	_____	_____
_____	_____	_____	_____	_____	_____	_____	_____	_____
_____	_____	_____	_____	_____	_____	_____	_____	_____

¹Type: C= Concentration, D=Depletion, RM=Reduced Matrix, CS=Covered or Coated Sand Grains. ²Location: PL=Pore Lining, M=Matrix

Hydric Soil Indicators: (Applicable to all LRRs, unless otherwise noted.)

- Histosol (A1)
- Histic Epipedon (A2)
- Black Histic (A3)
- Hydrogen Sulfide (A4)
- Depleted Below Dark Surface (A11)
- Thick Dark Surface (A12)
- Sandy Mucky Mineral (S1)
- Sandy Gleyed Matrix (S4)
- Sandy Redox (S5)
- Stripped Matrix (S6)
- Loamy Mucky Mineral (F1) **(except MLRA 1)**
- Loamy Gleyed Matrix (F2)
- Depleted Matrix (F3)
- Redox Dark Surface (F6)
- Depleted Dark Surface (F7)
- Redox Depressions (F8)

Indicators for Problematic Hydric Soils³:

- 2 cm Muck (A10)
- Red Parent Material (TF2)
- Very Shallow Dark Surface (TF12)
- Other (Explain in Remarks)

³Indicators of hydrophytic vegetation and wetland hydrology must be present, unless disturbed or problematic.

Restrictive Layer (if present):

Type: _____
 Depth (inches): _____

Hydric Soils Present? Yes No

Remarks: 2 chroma with no redox features

HYDROLOGY

Wetland Hydrology Indicators:

Primary Indicators (minimum of one required; check all that apply)

- Surface Water (A1)
- High Water Table (A2)
- Saturation (A3)
- Water Marks (B1)
- Sediment Deposits (B2)
- Drift Deposits (B3)
- Algal Mat or Crust (B4)
- Iron Deposits (B5)
- Surface Soil Cracks (B6)
- Inundation Visible on Aerial Imagery (B7)
- Sparsely Vegetated Concave Surface (B8)
- Water-Stained Leaves (B9) **(except MLRA 1, 2, 4A, and 4B)**
- Salt Crust (B11)
- Aquatic Invertebrates (B13)
- Hydrogen Sulfide Odor (C1)
- Oxidized Rhizospheres along Living Roots (C3)
- Presence of Reduced Iron (C4)
- Recent Iron Reduction in Tilled Soils (C6)
- Stunted or Stresses Plants (D1) **(LRR A)**
- Other (Explain in Remarks)

Secondary Indicators (2 or more required)

- Water-Stained Leaves (B9) **(MLRA 1, 2, 4A, and 4B)**
- Drainage Patterns (B10)
- Dry-Season Water Table (C2)
- Saturation Visible on Aerial Imagery (C9)
- Geomorphic Position (D2)
- Shallow Aquitard (D3)
- FAC-Neutral Test (D5)
- Raised Ant Mounds (D6) **(LRR A)**
- Frost-Heave Hummocks (D7)

Field Observations:

Surface Water Present? Yes No Depth (inches): _____
 Water Table Present? Yes No Depth (inches): _____
 Saturation Present? (includes capillary fringe) Yes No Depth (inches): _____

Wetland Hydrology Present? Yes No

Describe Recorded Data (stream gauge, monitoring well, aerial photos, previous inspections), if available:

Remarks: No saturation or water table observed in sample plot

WETLAND DETERMINATION DATA FORM – Western Mountains, Valleys, and Coast Region

Project Site: Sound Transit East Link Extension Project City/County: Bellevue/King Sampling Date: April 9, 2013
 Applicant/Owner: Sound Transit State: WA Sampling Point: Lake Bellevue SPU
 Investigator(s): C Douglas & J. Pursley Section, Township, Range: S29, T24N, R5E
 Landform (hillslope, terrace, etc.): Narrow area between railroad and Lake Local relief (concave, convex, none): concave Slope (%): 0% to 1%
 Subregion (LRR): A Lat: 47.62N Long: 122.18W Datum: _____
 Soil Map Unit Name: Alderwood gravelly sandy loam NWI classification: PUBH
 Are climatic / hydrologic conditions on the site typical for this time of year? Yes No (If no, explain in Remarks.)
 Are Vegetation , Soil , or Hydrology , significantly disturbed? Are "Normal Circumstances" present? Yes No
 Are Vegetation , Soil , or Hydrology , naturally problematic? (If needed, explain any answers in Remarks.)

SUMMARY OF FINDINGS – Attach site map showing sampling point locations, transects, important features, etc.

Hydrophytic Vegetation Present?	Yes <input checked="" type="checkbox"/>	No <input type="checkbox"/>	Is the Sampled Area within a Wetland?		
Hydric Soil Present?	Yes <input type="checkbox"/>	No <input checked="" type="checkbox"/>		Yes <input type="checkbox"/>	No <input checked="" type="checkbox"/>
Wetland Hydrology Present?	Yes <input type="checkbox"/>	No <input checked="" type="checkbox"/>			
Remarks: The Upland soil plot is located in a narrow area between railroad tracks and development on Lake Bellevue. Wetland includes depressional HGM class.					

VEGETATION – Use scientific names of plants

Tree Stratum (Plot size: 30 foot radius)	Absolute % Cover	Dominant Species?	Indicator Status	Dominance Test Worksheet:																
1. <u><i>Populus trichocarpa</i></u>	<u>60</u>	<u>yes</u>	<u>FAC</u>	Number of Dominant Species That Are OBL, FACW, or FAC: <u>4</u> (A) Total Number of Dominant Species Across All Strata: <u>7</u> (B) Percent of Dominant Species That Are OBL, FACW, or FAC: <u>57</u> (A/B)																
2. <u><i>Alnus rubra</i></u>	<u>20</u>	<u>yes</u>	<u>FAC</u>																	
3. _____	_____	_____	_____																	
4. _____	_____	_____	_____																	
50% = <u>1</u> , 20% = <u>1</u>	<u>80</u>	= Total Cover		Prevalence Index worksheet: <table style="width: 100%; border: none;"> <tr> <td style="text-align: center;">Total % Cover of:</td> <td style="text-align: center;">Multiply by:</td> </tr> <tr> <td>OBL species _____</td> <td>x1 = _____</td> </tr> <tr> <td>FACW species _____</td> <td>x2 = _____</td> </tr> <tr> <td>FAC species _____</td> <td>x3 = _____</td> </tr> <tr> <td>FACU species _____</td> <td>x4 = _____</td> </tr> <tr> <td>UPL species _____</td> <td>x5 = _____</td> </tr> <tr> <td>Column Totals: _____ (A)</td> <td>_____ (B)</td> </tr> <tr> <td colspan="2" style="text-align: center;">Prevalence Index = B/A = _____</td> </tr> </table>	Total % Cover of:	Multiply by:	OBL species _____	x1 = _____	FACW species _____	x2 = _____	FAC species _____	x3 = _____	FACU species _____	x4 = _____	UPL species _____	x5 = _____	Column Totals: _____ (A)	_____ (B)	Prevalence Index = B/A = _____	
Total % Cover of:	Multiply by:																			
OBL species _____	x1 = _____																			
FACW species _____	x2 = _____																			
FAC species _____	x3 = _____																			
FACU species _____	x4 = _____																			
UPL species _____	x5 = _____																			
Column Totals: _____ (A)	_____ (B)																			
Prevalence Index = B/A = _____																				
<u>Sapling/Shrub Stratum (Plot size: 15 foot radius)</u>																				
1. <u><i>Ilex aquifolium</i></u>	<u>10</u>	<u>yes</u>	<u>FACU</u>																	
2. <u><i>Rubus armeniacus</i></u>	<u>30</u>	<u>yes</u>	<u>FACU</u>																	
3. _____	_____	_____	_____																	
4. _____	_____	_____	_____																	
5. _____	_____	_____	_____																	
50% = <u>1</u> , 20% = <u>1</u>	<u>40</u>	= Total Cover																		
<u>Herb Stratum (Plot size: 3 foot radius)</u>																				
1. <u><i>Epilobium watsonii</i></u>	<u>10</u>	<u>yes</u>	<u>FACW</u>	Hydrophytic Vegetation Indicators: <input type="checkbox"/> 1 – Rapid Test for Hydrophytic Vegetation <input checked="" type="checkbox"/> 2 - Dominance Test is >50% <input type="checkbox"/> 3 - Prevalence Index is ≤3.0 ¹ <input type="checkbox"/> 4 - Morphological Adaptations ¹ (Provide supporting data in Remarks or on a separate sheet) <input type="checkbox"/> 5 - Wetland Non-Vascular Plants ¹ <input type="checkbox"/> Problematic Hydrophytic Vegetation ¹ (Explain) ¹ Indicators of hydric soil and wetland hydrology must be present, unless disturbed or problematic.																
2. <u><i>Equisetum arvense</i></u>	<u>5</u>	<u>yes</u>	<u>FAC</u>																	
3. _____	_____	_____	_____																	
4. _____	_____	_____	_____																	
5. _____	_____	_____	_____																	
6. _____	_____	_____	_____																	
7. _____	_____	_____	_____																	
8. _____	_____	_____	_____																	
9. _____	_____	_____	_____																	
10. _____	_____	_____	_____																	
11. _____	_____	_____	_____																	
50% = <u>1</u> , 20% = <u>1</u>	<u>15</u>	= Total Cover																		
<u>Woody Vine Stratum (Plot size: 3 foot radius)</u>																				
1. <u><i>Hedera helix</i></u>	<u>100</u>	<u>yes</u>	<u>UPL</u>	Hydrophytic Vegetation Present? Yes <input checked="" type="checkbox"/> No <input type="checkbox"/>																
2. _____	_____	_____	_____																	
50% = <u>1</u> , 20% = <u>0</u>	<u>100</u>	= Total Cover																		
% Bare Ground in Herb Stratum <u>70</u>																				

Remarks: 57% dominant wetland vegetation per the Dominance Test

SOIL

Profile Description: (Describe to the depth needed to document the indicator or confirm the absence of indicators.)								
Depth (inches)	Matrix		Redox Features				Texture	Remarks
	Color (moist)	%	Color (moist)	%	Type ¹	Loc ²		
0 to 3	10YR 3/3	100	None	None	None	None	Sandy loam	w/gravel and coarse root matt
3 to 18+	10YR 3/3	100	None	None	None	None	Sandy loam	w/gravel, cobble, & angular rock
¹ Type: C= Concentration, D=Depletion, RM=Reduced Matrix, CS=Covered or Coated Sand Grains.			² Location: PL=Pore Lining, M=Matrix					
Hydric Soil Indicators: (Applicable to all LRRs, unless otherwise noted.)						Indicators for Problematic Hydric Soils³:		
<input type="checkbox"/> Histosol (A1)			<input type="checkbox"/> Sandy Redox (S5)			<input type="checkbox"/> 2 cm Muck (A10)		
<input type="checkbox"/> Histic Epipedon (A2)			<input type="checkbox"/> Stripped Matrix (S6)			<input type="checkbox"/> Red Parent Material (TF2)		
<input type="checkbox"/> Black Histic (A3)			<input type="checkbox"/> Loamy Mucky Mineral (F1) (except MLRA 1)			<input type="checkbox"/> Very Shallow Dark Surface (TF12)		
<input type="checkbox"/> Hydrogen Sulfide (A4)			<input type="checkbox"/> Loamy Gleyed Matrix (F2)			<input type="checkbox"/> Other (Explain in Remarks)		
<input type="checkbox"/> Depleted Below Dark Surface (A11)			<input type="checkbox"/> Depleted Matrix (F3)			³ Indicators of hydrophytic vegetation and wetland hydrology must be present, unless disturbed or problematic.		
<input type="checkbox"/> Thick Dark Surface (A12)			<input type="checkbox"/> Redox Dark Surface (F6)					
<input type="checkbox"/> Sandy Mucky Mineral (S1)			<input type="checkbox"/> Depleted Dark Surface (F7)					
<input type="checkbox"/> Sandy Gleyed Matrix (S4)			<input type="checkbox"/> Redox Depressions (F8)					
Restrictive Layer (if present):					Hydric Soils Present?			
Type: _____					Yes <input type="checkbox"/> No <input checked="" type="checkbox"/>			
Depth (inches): _____								
Remarks: 3 chroma with no redox features and several pieces of concrete and asphalt found in the adjacent soils. Fill from railroad.								

HYDROLOGY

Wetland Hydrology Indicators:			
Primary Indicators (minimum of one required; check all that apply)		Secondary Indicators (2 or more required)	
<input type="checkbox"/> Surface Water (A1)	<input type="checkbox"/> Water-Stained Leaves (B9)	<input type="checkbox"/> Water-Stained Leaves (B9)	
<input type="checkbox"/> High Water Table (A2)	(except MLRA 1, 2, 4A, and 4B)	(MLRA 1, 2, 4A, and 4B)	
<input type="checkbox"/> Saturation (A3)	<input type="checkbox"/> Salt Crust (B11)	<input type="checkbox"/> Drainage Patterns (B10)	
<input type="checkbox"/> Water Marks (B1)	<input type="checkbox"/> Aquatic Invertebrates (B13)	<input type="checkbox"/> Dry-Season Water Table (C2)	
<input type="checkbox"/> Sediment Deposits (B2)	<input type="checkbox"/> Hydrogen Sulfide Odor (C1)	<input type="checkbox"/> Saturation Visible on Aerial Imagery (C9)	
<input type="checkbox"/> Drift Deposits (B3)	<input type="checkbox"/> Oxidized Rhizospheres along Living Roots (C3)	<input type="checkbox"/> Geomorphic Position (D2)	
<input type="checkbox"/> Algal Mat or Crust (B4)	<input type="checkbox"/> Presence of Reduced Iron (C4)	<input type="checkbox"/> Shallow Aquitard (D3)	
<input type="checkbox"/> Iron Deposits (B5)	<input type="checkbox"/> Recent Iron Reduction in Tilled Soils (C6)	<input type="checkbox"/> FAC-Neutral Test (D5)	
<input type="checkbox"/> Surface Soil Cracks (B6)	<input type="checkbox"/> Stunted or Stresses Plants (D1) (LRR A)	<input type="checkbox"/> Raised Ant Mounds (D6) (LRR A)	
<input type="checkbox"/> Inundation Visible on Aerial Imagery (B7)	<input type="checkbox"/> Other (Explain in Remarks)	<input type="checkbox"/> Frost-Heave Hummocks (D7)	
<input type="checkbox"/> Sparsely Vegetated Concave Surface (B8)			
Field Observations:		Wetland Hydrology Present?	
Surface Water Present?	Yes <input type="checkbox"/> No <input checked="" type="checkbox"/>	Yes <input type="checkbox"/> No <input checked="" type="checkbox"/>	
Water Table Present?	Yes <input type="checkbox"/> No <input checked="" type="checkbox"/>		
Saturation Present? (includes capillary fringe)	Yes <input type="checkbox"/> No <input checked="" type="checkbox"/>		
Depth (inches): _____			
Depth (inches): _____			
Depth (inches): _____			
Describe Recorded Data (stream gauge, monitoring well, aerial photos, previous inspections), if available:			
Remarks: No saturation or water table observed in sample plot and the soil was strongly compacted with concrete and other evidence of fill.			

WETLAND DETERMINATION DATA FORM – Western Mountains, Valleys, and Coast Region

Project Site: Sound Transit East Link Extension Project City/County: Bellevue/King Sampling Date: April 9, 2013
 Applicant/Owner: Sound Transit State: WA Sampling Point: Lake Bellevue SPW
 Investigator(s): C Douglas & J. Pursley Section, Township, Range: S29, T24N, R5E
 Landform (hillslope, terrace, etc.): Depression/Laket Local relief (concave, convex, none): concave Slope (%): 0% to 2%
 Subregion (LRR): A Lat: 47.62N Long: 122.18W Datum: _____
 Soil Map Unit Name: Alderwood gravelly sandy loam NWI classification: PUBH
 Are climatic / hydrologic conditions on the site typical for this time of year? Yes No (If no, explain in Remarks.)
 Are Vegetation , Soil , or Hydrology , significantly disturbed? Are "Normal Circumstances" present? Yes No
 Are Vegetation , Soil , or Hydrology , naturally problematic? (If needed, explain any answers in Remarks.)

SUMMARY OF FINDINGS – Attach site map showing sampling point locations, transects, important features, etc.

Hydrophytic Vegetation Present?	Yes <input checked="" type="checkbox"/>	No <input type="checkbox"/>	Is the Sampled Area within a Wetland?	Yes <input checked="" type="checkbox"/>	No <input type="checkbox"/>
Hydric Soil Present?	Yes <input checked="" type="checkbox"/>	No <input type="checkbox"/>		Yes <input checked="" type="checkbox"/>	No <input type="checkbox"/>
Wetland Hydrology Present?	Yes <input checked="" type="checkbox"/>	No <input type="checkbox"/>		Yes <input checked="" type="checkbox"/>	No <input type="checkbox"/>
Remarks: Wetland Lake Bellevue is located east of an existing rail line and is surrounded by a commercial business park and parking lots.					

VEGETATION – Use scientific names of plants

Tree Stratum (Plot size: 30 foot radius)	Absolute % Cover	Dominant Species?	Indicator Status	Dominance Test Worksheet:																
1. <u>Salix hookeriana</u>	<u>30</u>	<u>yes</u>	<u>FACW</u>	Number of Dominant Species That Are OBL, FACW, or FAC: <u>5</u> (A) Total Number of Dominant Species Across All Strata: <u>6</u> (B) Percent of Dominant Species That Are OBL, FACW, or FAC: <u>83</u> (A/B)																
2. <u>Populus balsamifera</u>	<u>50</u>	<u>yes</u>	<u>FAC</u>																	
3. _____	_____	_____	_____																	
4. _____	_____	_____	_____																	
50% = <u>1</u> , 20% = <u>1</u>	<u>80</u>	= Total Cover		Prevalence Index worksheet: <table style="width: 100%; border: none;"> <tr> <td style="text-align: right;">Total % Cover of:</td> <td style="text-align: right;">Multiply by:</td> </tr> <tr> <td>OBL species _____</td> <td>x1 = _____</td> </tr> <tr> <td>FACW species _____</td> <td>x2 = _____</td> </tr> <tr> <td>FAC species _____</td> <td>x3 = _____</td> </tr> <tr> <td>FACU species _____</td> <td>x4 = _____</td> </tr> <tr> <td>UPL species _____</td> <td>x5 = _____</td> </tr> <tr> <td>Column Totals: _____ (A)</td> <td>_____ (B)</td> </tr> <tr> <td colspan="2" style="text-align: center;">Prevalence Index = B/A = _____</td> </tr> </table>	Total % Cover of:	Multiply by:	OBL species _____	x1 = _____	FACW species _____	x2 = _____	FAC species _____	x3 = _____	FACU species _____	x4 = _____	UPL species _____	x5 = _____	Column Totals: _____ (A)	_____ (B)	Prevalence Index = B/A = _____	
Total % Cover of:	Multiply by:																			
OBL species _____	x1 = _____																			
FACW species _____	x2 = _____																			
FAC species _____	x3 = _____																			
FACU species _____	x4 = _____																			
UPL species _____	x5 = _____																			
Column Totals: _____ (A)	_____ (B)																			
Prevalence Index = B/A = _____																				
Sapling/Shrub Stratum (Plot size: 15 foot radius)																				
1. <u>Spiraea douglasii</u>	<u>20</u>	<u>yes</u>	<u>FACW</u>																	
2. _____	_____	_____	_____																	
3. _____	_____	_____	_____																	
4. _____	_____	_____	_____																	
5. _____	_____	_____	_____																	
50% = <u>1</u> , 20% = _____	<u>20</u>	= Total Cover																		
Herb Stratum (Plot size: 3 foot radius)																				
1. <u>Phalaris arundinacea</u>	<u>20</u>	<u>yes</u>	<u>FACW</u>	Hydrophytic Vegetation Indicators: <input type="checkbox"/> 1 – Rapid Test for Hydrophytic Vegetation <input checked="" type="checkbox"/> 2 - Dominance Test is >50% <input type="checkbox"/> 3 - Prevalence Index is $\leq 3.0^1$ <input type="checkbox"/> 4 - Morphological Adaptations ¹ (Provide supporting data in Remarks or on a separate sheet) <input type="checkbox"/> 5 - Wetland Non-Vascular Plants ¹ <input type="checkbox"/> Problematic Hydrophytic Vegetation ¹ (Explain) ¹ Indicators of hydric soil and wetland hydrology must be present, unless disturbed or problematic.																
2. <u>Juncus effusus</u>	<u>5</u>	<u>yes</u>	<u>FACW</u>																	
3. _____	_____	_____	_____																	
4. _____	_____	_____	_____																	
5. _____	_____	_____	_____																	
6. _____	_____	_____	_____																	
7. _____	_____	_____	_____																	
8. _____	_____	_____	_____																	
9. _____	_____	_____	_____																	
10. _____	_____	_____	_____																	
11. _____	_____	_____	_____																	
50% = <u>1</u> , 20% = <u>1</u>	<u>25</u>	= Total Cover																		
Woody Vine Stratum (Plot size: 3 foot radius)																				
1. <u>Hedera helix</u>	<u>25</u>	<u>yes</u>	<u>UPL</u>																	
2. _____	_____	_____	_____																	
50% = <u>1</u> , 20% = _____	<u>25</u>	= Total Cover																		
% Bare Ground in Herb Stratum <u>4</u>																				

Remarks: 83% dominant wetland vegetation per the Dominance Test. Soil plot was located at the Lake edge.

SOIL

Profile Description: (Describe to the depth needed to document the indicator or confirm the absence of indicators.)								
Depth (inches)	Matrix		Redox Features				Texture	Remarks
	Color (moist)	%	Color (moist)	%	Type ¹	Loc ²		
0 to 2	<u>10YR 2/1</u>	<u>100</u>	<u>None</u>	<u>None</u>	<u>None</u>	<u>None</u>	<u>Loam</u>	<u>w/roots throughout</u>
2 to 18+	<u>10YR 2/1</u>	<u>100</u>	<u>None</u>	<u>None</u>	<u>None</u>	<u>None</u>	<u>Sandy Loam</u>	<u>w/rocks and sandt</u>
_____	_____	_____	_____	_____	_____	_____	_____	_____
_____	_____	_____	_____	_____	_____	_____	_____	_____
_____	_____	_____	_____	_____	_____	_____	_____	_____
_____	_____	_____	_____	_____	_____	_____	_____	_____
_____	_____	_____	_____	_____	_____	_____	_____	_____
¹ Type: C= Concentration, D=Depletion, RM=Reduced Matrix, CS=Covered or Coated Sand Grains. ² Location: PL=Pore Lining, M=Matrix								
Hydric Soil Indicators: (Applicable to all LRRs, unless otherwise noted.)						Indicators for Problematic Hydric Soils³:		
<input type="checkbox"/> Histosol (A1)			<input type="checkbox"/> Sandy Redox (S5)			<input type="checkbox"/> 2 cm Muck (A10)		
<input type="checkbox"/> Histic Epipedon (A2)			<input type="checkbox"/> Stripped Matrix (S6)			<input type="checkbox"/> Red Parent Material (TF2)		
<input type="checkbox"/> Black Histic (A3)			<input type="checkbox"/> Loamy Mucky Mineral (F1) (except MLRA 1)			<input type="checkbox"/> Very Shallow Dark Surface (TF12)		
<input type="checkbox"/> Hydrogen Sulfide (A4)			<input type="checkbox"/> Loamy Gleyed Matrix (F2)			<input type="checkbox"/> Other (Explain in Remarks)		
<input type="checkbox"/> Depleted Below Dark Surface (A11)			<input type="checkbox"/> Depleted Matrix (F3)			³ Indicators of hydrophytic vegetation and wetland hydrology must be present, unless disturbed or problematic.		
<input checked="" type="checkbox"/> Thick Dark Surface (A12)			<input type="checkbox"/> Redox Dark Surface (F6)					
<input type="checkbox"/> Sandy Mucky Mineral (S1)			<input type="checkbox"/> Depleted Dark Surface (F7)					
<input type="checkbox"/> Sandy Gleyed Matrix (S4)			<input type="checkbox"/> Redox Depressions (F8)					
Restrictive Layer (if present):					Hydric Soils Present?			
Type: _____					Yes <input checked="" type="checkbox"/> No <input type="checkbox"/>			
Depth (inches): _____								
Remarks: Fines are limited in the soil due to constant wave action from the Lake surface.								

HYDROLOGY

Wetland Hydrology Indicators:			
Primary Indicators (minimum of one required; check all that apply)		Secondary Indicators (2 or more required)	
<input checked="" type="checkbox"/> Surface Water (A1)	<input type="checkbox"/> Water-Stained Leaves (B9)	<input type="checkbox"/> Water-Stained Leaves (B9)	
<input checked="" type="checkbox"/> High Water Table (A2)	(except MLRA 1, 2, 4A, and 4B)	(MLRA 1, 2, 4A, and 4B)	
<input checked="" type="checkbox"/> Saturation (A3)	<input type="checkbox"/> Salt Crust (B11)	<input type="checkbox"/> Drainage Patterns (B10)	
<input type="checkbox"/> Water Marks (B1)	<input type="checkbox"/> Aquatic Invertebrates (B13)	<input type="checkbox"/> Dry-Season Water Table (C2)	
<input type="checkbox"/> Sediment Deposits (B2)	<input checked="" type="checkbox"/> Hydrogen Sulfide Odor (C1)	<input type="checkbox"/> Saturation Visible on Aerial Imagery (C9)	
<input checked="" type="checkbox"/> Drift Deposits (B3)	<input type="checkbox"/> Oxidized Rhizospheres along Living Roots (C3)	<input type="checkbox"/> Geomorphic Position (D2)	
<input type="checkbox"/> Algal Mat or Crust (B4)	<input type="checkbox"/> Presence of Reduced Iron (C4)	<input type="checkbox"/> Shallow Aquitard (D3)	
<input type="checkbox"/> Iron Deposits (B5)	<input type="checkbox"/> Recent Iron Reduction in Tilled Soils (C6)	<input type="checkbox"/> FAC-Neutral Test (D5)	
<input type="checkbox"/> Surface Soil Cracks (B6)	<input type="checkbox"/> Stunted or Stresses Plants (D1) (LRR A)	<input type="checkbox"/> Raised Ant Mounds (D6) (LRR A)	
<input checked="" type="checkbox"/> Inundation Visible on Aerial Imagery (B7)	<input type="checkbox"/> Other (Explain in Remarks)	<input type="checkbox"/> Frost-Heave Hummocks (D7)	
<input type="checkbox"/> Sparsely Vegetated Concave Surface (B8)			
Field Observations:		Wetland Hydrology Present?	
Surface Water Present?	Yes <input type="checkbox"/> No <input checked="" type="checkbox"/>	Yes <input checked="" type="checkbox"/> No <input type="checkbox"/>	
Water Table Present?	Yes <input checked="" type="checkbox"/> No <input type="checkbox"/>		
Saturation Present? (includes capillary fringe)	Yes <input checked="" type="checkbox"/> No <input type="checkbox"/>		
Depth (inches): _____	Depth (inches): <u>2 inch</u>		
Depth (inches): _____	Depth (inches): <u>Surface</u>		
Describe Recorded Data (stream gauge, monitoring well, aerial photos, previous inspections), if available:			
Remarks: Saturation year round by the constant fluctuation of Lake Bellevue and debris at the Lake outflow to Sturtevant Creek.			

WETLAND DETERMINATION DATA FORM – Western Mountains, Valleys, and Coast Region

Project Site: Sound Transit East Link Extension Project City/County: Bellevue/King Sampling Date: Feb. 21, 2013
 Applicant/Owner: Sound Transit State: WA Sampling Point: Mercer Slough SP10U
 Investigator(s): C Douglas & J. Pursley Section, Township, Range: S5, T24N, R5E
 Landform (hillslope, terrace, etc.): Large wetland system - Mercer Slough Local relief (concave, convex, none): concave Slope (%): 0% to 4%
 Subregion (LRR): A Lat: 47.58N Long: 122.18W Datum: _____
 Soil Map Unit Name: Seattle Muck NWI classification: PFO, PSS, PEM
 Are climatic / hydrologic conditions on the site typical for this time of year? Yes No (If no, explain in Remarks.)
 Are Vegetation , Soil , or Hydrology , significantly disturbed? Are "Normal Circumstances" present? Yes No
 Are Vegetation , Soil , or Hydrology , naturally problematic? (If needed, explain any answers in Remarks.)

SUMMARY OF FINDINGS – Attach site map showing sampling point locations, transects, important features, etc.

Hydrophytic Vegetation Present?	Yes <input type="checkbox"/>	No <input checked="" type="checkbox"/>	Is the Sampled Area within a Wetland?	Yes <input type="checkbox"/>	No <input checked="" type="checkbox"/>
Hydric Soil Present?	Yes <input type="checkbox"/>	No <input checked="" type="checkbox"/>		Yes <input type="checkbox"/>	No <input checked="" type="checkbox"/>
Wetland Hydrology Present?	Yes <input type="checkbox"/>	No <input checked="" type="checkbox"/>		Yes <input type="checkbox"/>	No <input checked="" type="checkbox"/>
Remarks: Wetland Mercer Slough is a large wetland associated with the Mercer Slough and Lake Washington. Only a portion of the west boundary of wetland delineated as part of this investigation. Area west of wetland boundary includes roads and associated fill prisms. Wetland includes depressional, lake-fringe, riverine, and slope HGM classes.					

VEGETATION – Use scientific names of plants

Tree Stratum (Plot size: 30 foot radius)	Absolute % Cover	Dominant Species?	Indicator Status	Dominance Test Worksheet:																
1. <u>Fraxinus latifolia</u>	<u>5</u>	<u>no</u>	<u>FACW</u>	Number of Dominant Species That Are OBL, FACW, or FAC: <u>1</u> (A) Total Number of Dominant Species Across All Strata: <u>3</u> (B) Percent of Dominant Species That Are OBL, FACW, or FAC: <u>37</u> (A/B)																
2. <u>Salix lasiandra</u>	<u>30</u>	<u>yes</u>	<u>FACW</u>																	
3. _____	_____	_____	_____																	
4. _____	_____	_____	_____																	
50% = <u>1</u> , 20% = <u>0</u>	<u>35</u>	= Total Cover		Prevalence Index worksheet: <table style="width: 100%; border: none;"> <tr> <td style="text-align: right;">Total % Cover of:</td> <td style="text-align: left;">Multiply by:</td> </tr> <tr> <td>OBL species _____</td> <td>x1 = _____</td> </tr> <tr> <td>FACW species _____</td> <td>x2 = _____</td> </tr> <tr> <td>FAC species _____</td> <td>x3 = _____</td> </tr> <tr> <td>FACU species _____</td> <td>x4 = _____</td> </tr> <tr> <td>UPL species _____</td> <td>x5 = _____</td> </tr> <tr> <td>Column Totals: _____ (A)</td> <td>_____ (B)</td> </tr> <tr> <td colspan="2" style="text-align: center;">Prevalence Index = B/A = _____</td> </tr> </table>	Total % Cover of:	Multiply by:	OBL species _____	x1 = _____	FACW species _____	x2 = _____	FAC species _____	x3 = _____	FACU species _____	x4 = _____	UPL species _____	x5 = _____	Column Totals: _____ (A)	_____ (B)	Prevalence Index = B/A = _____	
Total % Cover of:	Multiply by:																			
OBL species _____	x1 = _____																			
FACW species _____	x2 = _____																			
FAC species _____	x3 = _____																			
FACU species _____	x4 = _____																			
UPL species _____	x5 = _____																			
Column Totals: _____ (A)	_____ (B)																			
Prevalence Index = B/A = _____																				
<u>Sapling/Shrub Stratum (Plot size: 15 foot radius)</u>																				
1. <u>Cornus sericea</u>	<u>15</u>	<u>no</u>	<u>FACW</u>																	
2. <u>Polygonum cuspidatum</u>	<u>10</u>	<u>no</u>	<u>FACU</u>																	
3. <u>Rubus armeniacus</u>	<u>25</u>	<u>yes</u>	<u>FACU</u>																	
4. <u>Sambucus racemosa</u>	<u>15</u>	<u>no</u>	<u>FACU</u>																	
5. <u>Symphoricarpos albus</u>	<u>50</u>	<u>yes</u>	<u>FACU</u>																	
50% = <u>0</u> , 20% = <u>2</u>	<u>100</u>	= Total Cover																		
<u>Herb Stratum (Plot size: 3 foot radius)</u>																				
1. _____	_____	_____	_____																	
2. _____	_____	_____	_____																	
3. _____	_____	_____	_____																	
4. _____	_____	_____	_____																	
5. _____	_____	_____	_____																	
6. _____	_____	_____	_____																	
7. _____	_____	_____	_____																	
8. _____	_____	_____	_____																	
9. _____	_____	_____	_____																	
10. _____	_____	_____	_____																	
11. _____	_____	_____	_____																	
50% = <u>1</u> , 20% = <u>0</u>	<u>0</u>	= Total Cover																		
<u>Woody Vine Stratum (Plot size: 3 foot radius)</u>																				
1. _____	_____	_____	_____																	
2. _____	_____	_____	_____																	
50% = _____, 20% = _____	<u>0</u>	= Total Cover																		
% Bare Ground in Herb Stratum <u>100</u>																				
<table style="width: 100%; border: none;"> <tr> <td style="width: 35%;">Hydrophytic Vegetation Present?</td> <td style="width: 10%;">Yes <input type="checkbox"/></td> <td style="width: 10%;">No <input checked="" type="checkbox"/></td> </tr> </table>				Hydrophytic Vegetation Present?	Yes <input type="checkbox"/>	No <input checked="" type="checkbox"/>														
Hydrophytic Vegetation Present?	Yes <input type="checkbox"/>	No <input checked="" type="checkbox"/>																		

Remarks: 37% dominant wetland vegetation per the Dominance Test

SOIL

Profile Description: (Describe to the depth needed to document the indicator or confirm the absence of indicators.)									
Depth (inches)	Matrix		Redox Features				Texture	Remarks	
	Color (moist)	%	Color (moist)	%	Type ¹	Loc ²			
0 to 10	<u>10YR 3/2</u>	<u>100</u>	<u>None</u>	<u>None</u>	<u>None</u>	<u>None</u>	<u>Loam</u>		
10 to 18+	<u>10YR 4/2</u>	<u>100</u>	<u>None</u>	<u>None</u>	<u>None</u>	<u>None</u>	<u>Loam</u>	<u>w/cobble</u>	

¹Type: C= Concentration, D=Depletion, RM=Reduced Matrix, CS=Covered or Coated Sand Grains. ²Location: PL=Pore Lining, M=Matrix

Hydric Soil Indicators: (Applicable to all LRRs, unless otherwise noted.)			Indicators for Problematic Hydric Soils ³ :		
<input type="checkbox"/> Histosol (A1)	<input type="checkbox"/> Sandy Redox (S5)	<input type="checkbox"/> 2 cm Muck (A10)			
<input type="checkbox"/> Histic Epipedon (A2)	<input type="checkbox"/> Stripped Matrix (S6)	<input type="checkbox"/> Red Parent Material (TF2)			
<input type="checkbox"/> Black Histic (A3)	<input type="checkbox"/> Loamy Mucky Mineral (F1) (except MLRA 1)	<input type="checkbox"/> Very Shallow Dark Surface (TF12)			
<input type="checkbox"/> Hydrogen Sulfide (A4)	<input type="checkbox"/> Loamy Gleyed Matrix (F2)	<input type="checkbox"/> Other (Explain in Remarks)			
<input type="checkbox"/> Depleted Below Dark Surface (A11)	<input type="checkbox"/> Depleted Matrix (F3)				
<input type="checkbox"/> Thick Dark Surface (A12)	<input type="checkbox"/> Redox Dark Surface (F6)				
<input type="checkbox"/> Sandy Mucky Mineral (S1)	<input type="checkbox"/> Depleted Dark Surface (F7)				
<input type="checkbox"/> Sandy Gleyed Matrix (S4)	<input type="checkbox"/> Redox Depressions (F8)				

³Indicators of hydrophytic vegetation and wetland hydrology must be present, unless disturbed or problematic.

Restrictive Layer (if present): Type: _____ Depth (inches): _____	Hydric Soils Present? Yes <input type="checkbox"/> No <input checked="" type="checkbox"/>
--	--

Remarks: 2 chroma with no redox features

HYDROLOGY

Wetland Hydrology Indicators:			
Primary Indicators (minimum of one required; check all that apply)		Secondary Indicators (2 or more required)	
<input type="checkbox"/> Surface Water (A1)	<input type="checkbox"/> Water-Stained Leaves (B9)	<input type="checkbox"/> Water-Stained Leaves (B9)	
<input type="checkbox"/> High Water Table (A2)	(except MLRA 1, 2, 4A, and 4B)	(MLRA 1, 2, 4A, and 4B)	
<input type="checkbox"/> Saturation (A3)	<input type="checkbox"/> Salt Crust (B11)	<input type="checkbox"/> Drainage Patterns (B10)	
<input type="checkbox"/> Water Marks (B1)	<input type="checkbox"/> Aquatic Invertebrates (B13)	<input type="checkbox"/> Dry-Season Water Table (C2)	
<input type="checkbox"/> Sediment Deposits (B2)	<input type="checkbox"/> Hydrogen Sulfide Odor (C1)	<input type="checkbox"/> Saturation Visible on Aerial Imagery (C9)	
<input type="checkbox"/> Drift Deposits (B3)	<input type="checkbox"/> Oxidized Rhizospheres along Living Roots (C3)	<input type="checkbox"/> Geomorphic Position (D2)	
<input type="checkbox"/> Algal Mat or Crust (B4)	<input type="checkbox"/> Presence of Reduced Iron (C4)	<input type="checkbox"/> Shallow Aquitard (D3)	
<input type="checkbox"/> Iron Deposits (B5)	<input type="checkbox"/> Recent Iron Reduction in Tilled Soils (C6)	<input type="checkbox"/> FAC-Neutral Test (D5)	
<input type="checkbox"/> Surface Soil Cracks (B6)	<input type="checkbox"/> Stunted or Stresses Plants (D1) (LRR A)	<input type="checkbox"/> Raised Ant Mounds (D6) (LRR A)	
<input type="checkbox"/> Inundation Visible on Aerial Imagery (B7)	<input type="checkbox"/> Other (Explain in Remarks)	<input type="checkbox"/> Frost-Heave Hummocks (D7)	
<input type="checkbox"/> Sparsely Vegetated Concave Surface (B8)			

Field Observations: Surface Water Present? Yes <input type="checkbox"/> No <input checked="" type="checkbox"/> Depth (inches): _____ Water Table Present? Yes <input type="checkbox"/> No <input checked="" type="checkbox"/> Depth (inches): _____ Saturation Present? (includes capillary fringe) Yes <input type="checkbox"/> No <input checked="" type="checkbox"/> Depth (inches): _____	Wetland Hydrology Present? Yes <input type="checkbox"/> No <input checked="" type="checkbox"/>
--	---

Describe Recorded Data (stream gauge, monitoring well, aerial photos, previous inspections), if available:

Remarks: No saturation or water table observed in sample plot

WETLAND DETERMINATION DATA FORM – Western Mountains, Valleys, and Coast Region

Project Site: Sound Transit East Link Extension Project City/County: Bellevue/King Sampling Date: Feb. 6, 2013
 Applicant/Owner: Sound Transit State: WA Sampling Point: Mercer Slough SP1W
 Investigator(s): C Douglas & J. Pursley Section, Township, Range: S5, T24N, R5E
 Landform (hillslope, terrace, etc.): Large wetland system - Mercer Slough Local relief (concave, convex, none): concave Slope (%): 0% to 4%
 Subregion (LRR): A Lat: 47.58N Long: 122.18W Datum: _____
 Soil Map Unit Name: Seattle Muck NWI classification: PFO, PSS, PEM
 Are climatic / hydrologic conditions on the site typical for this time of year? Yes No (If no, explain in Remarks.)
 Are Vegetation , Soil , or Hydrology , significantly disturbed? Are "Normal Circumstances" present? Yes No
 Are Vegetation , Soil , or Hydrology , naturally problematic? (If needed, explain any answers in Remarks.)

SUMMARY OF FINDINGS – Attach site map showing sampling point locations, transects, important features, etc.

Hydrophytic Vegetation Present?	Yes <input checked="" type="checkbox"/>	No <input type="checkbox"/>	Is the Sampled Area within a Wetland?	Yes <input checked="" type="checkbox"/>	No <input type="checkbox"/>
Hydric Soil Present?	Yes <input checked="" type="checkbox"/>	No <input type="checkbox"/>		Yes <input checked="" type="checkbox"/>	No <input type="checkbox"/>
Wetland Hydrology Present?	Yes <input checked="" type="checkbox"/>	No <input type="checkbox"/>		Yes <input checked="" type="checkbox"/>	No <input type="checkbox"/>
Remarks: Wetland Mercer Slough is a large wetland associated with the Mercer Slough and Lake Washington. Only a portion of the west boundary of wetland delineated as part of this investigation. Area west of wetland boundary includes roads and associated fill prisms. Wetland includes depressional, lake-fringe, riverine, and slope HGM classes.					

VEGETATION – Use scientific names of plants

Tree Stratum (Plot size: 30 foot radius)	Absolute % Cover	Dominant Species?	Indicator Status	Dominance Test Worksheet:																
1. <u><i>Populus trichocarpa</i></u>	<u>40</u>	<u>yes</u>	<u>FAC</u>	Number of Dominant Species That Are OBL, FACW, or FAC: <u>3</u> (A) Total Number of Dominant Species Across All Strata: <u>4</u> (B) Percent of Dominant Species That Are OBL, FACW, or FAC: <u>75</u> (A/B)																
2. <u><i>Thuja plicata</i></u>	<u>40</u>	<u>yes</u>	<u>FAC</u>																	
3. _____	_____	_____	_____																	
4. _____	_____	_____	_____																	
50% = <u>2</u> , 20% = <u>0</u>	<u>80</u>	= Total Cover		Prevalence Index worksheet: <table style="width: 100%; border: none;"> <tr> <td style="text-align: right;">Total % Cover of:</td> <td style="text-align: right;">Multiply by:</td> </tr> <tr> <td>OBL species _____</td> <td>x1 = _____</td> </tr> <tr> <td>FACW species _____</td> <td>x2 = _____</td> </tr> <tr> <td>FAC species _____</td> <td>x3 = _____</td> </tr> <tr> <td>FACU species _____</td> <td>x4 = _____</td> </tr> <tr> <td>UPL species _____</td> <td>x5 = _____</td> </tr> <tr> <td>Column Totals: _____ (A)</td> <td>_____ (B)</td> </tr> <tr> <td colspan="2" style="text-align: center;">Prevalence Index = B/A = _____</td> </tr> </table>	Total % Cover of:	Multiply by:	OBL species _____	x1 = _____	FACW species _____	x2 = _____	FAC species _____	x3 = _____	FACU species _____	x4 = _____	UPL species _____	x5 = _____	Column Totals: _____ (A)	_____ (B)	Prevalence Index = B/A = _____	
Total % Cover of:	Multiply by:																			
OBL species _____	x1 = _____																			
FACW species _____	x2 = _____																			
FAC species _____	x3 = _____																			
FACU species _____	x4 = _____																			
UPL species _____	x5 = _____																			
Column Totals: _____ (A)	_____ (B)																			
Prevalence Index = B/A = _____																				
<u>Sapling/Shrub Stratum (Plot size: 15 foot radius)</u>																				
1. <u><i>Rubus armeniacus</i></u>	<u>10</u>	<u>yes</u>	<u>FACU</u>																	
2. _____	_____	_____	_____																	
3. _____	_____	_____	_____																	
4. _____	_____	_____	_____																	
5. _____	_____	_____	_____																	
50% = <u>1</u> , 20% = <u>0</u>	<u>10</u>	= Total Cover																		
<u>Herb Stratum (Plot size: 3 foot radius)</u>																				
1. <u><i>Athyrium filix-femina</i></u>	<u>20</u>	<u>no</u>	<u>FAC</u>	Hydrophytic Vegetation Indicators: <input type="checkbox"/> 1 – Rapid Test for Hydrophytic Vegetation <input checked="" type="checkbox"/> 2 - Dominance Test is >50% <input type="checkbox"/> 3 - Prevalence Index is $\leq 3.0^1$ <input type="checkbox"/> 4 - Morphological Adaptations ¹ (Provide supporting data in Remarks or on a separate sheet) <input type="checkbox"/> 5 - Wetland Non-Vascular Plants ¹ <input type="checkbox"/> Problematic Hydrophytic Vegetation ¹ (Explain) ¹ Indicators of hydric soil and wetland hydrology must be present, unless disturbed or problematic.																
2. <u><i>Equisetum telmateia</i></u>	<u>10</u>	<u>no</u>	<u>FACW</u>																	
3. <u><i>Phalaris arundinacea</i></u>	<u>80</u>	<u>yes</u>	<u>FACW</u>																	
4. _____	_____	_____	_____																	
5. _____	_____	_____	_____																	
6. _____	_____	_____	_____																	
7. _____	_____	_____	_____																	
8. _____	_____	_____	_____																	
9. _____	_____	_____	_____																	
10. _____	_____	_____	_____																	
11. _____	_____	_____	_____																	
50% = <u>1</u> , 20% = <u>0</u>	<u>100</u>	= Total Cover																		
<u>Woody Vine Stratum (Plot size: 3 foot radius)</u>																				
1. _____	_____	_____	_____																	
2. _____	_____	_____	_____																	
50% = _____, 20% = _____	<u>0</u>	= Total Cover																		
% Bare Ground in Herb Stratum <u>0</u>																				
Hydrophytic Vegetation Present? Yes <input checked="" type="checkbox"/> No <input type="checkbox"/>																				

Remarks: 75% dominant wetland vegetation per the Dominance Test

SOIL

Profile Description: (Describe to the depth needed to document the indicator or confirm the absence of indicators.)								
Depth (inches)	Matrix		Redox Features				Texture	Remarks
	Color (moist)	%	Color (moist)	%	Type ¹	Loc ²		
0 to 7	<u>10YR 2/1</u>	<u>100</u>	<u>None</u>	<u>None</u>	<u>None</u>	<u>None</u>	<u>Silt loam</u>	<u>w/dense root material</u>
7 to 10	<u>10YR 2/1</u>	<u>100</u>	<u>None</u>	<u>None</u>	<u>None</u>	<u>None</u>	<u>Silt</u>	_____
10 to 18+	<u>10YR 2/1</u>	<u>100</u>	<u>None</u>	<u>None</u>	<u>None</u>	<u>None</u>	<u>Silt</u>	<u>w/dense organic material</u>
_____	_____	_____	_____	_____	_____	_____	_____	_____
_____	_____	_____	_____	_____	_____	_____	_____	_____
_____	_____	_____	_____	_____	_____	_____	_____	_____
_____	_____	_____	_____	_____	_____	_____	_____	_____
¹ Type: C= Concentration, D=Depletion, RM=Reduced Matrix, CS=Covered or Coated Sand Grains. ² Location: PL=Pore Lining, M=Matrix								
Hydric Soil Indicators: (Applicable to all LRRs, unless otherwise noted.)						Indicators for Problematic Hydric Soils³:		
<input type="checkbox"/> Histosol (A1)			<input type="checkbox"/> Sandy Redox (S5)			<input type="checkbox"/> 2 cm Muck (A10)		
<input type="checkbox"/> Histic Epipedon (A2)			<input type="checkbox"/> Stripped Matrix (S6)			<input type="checkbox"/> Red Parent Material (TF2)		
<input type="checkbox"/> Black Histic (A3)			<input type="checkbox"/> Loamy Mucky Mineral (F1) (except MLRA 1)			<input type="checkbox"/> Very Shallow Dark Surface (TF12)		
<input type="checkbox"/> Hydrogen Sulfide (A4)			<input type="checkbox"/> Loamy Gleyed Matrix (F2)			<input type="checkbox"/> Other (Explain in Remarks)		
<input type="checkbox"/> Depleted Below Dark Surface (A11)			<input type="checkbox"/> Depleted Matrix (F3)			³ Indicators of hydrophytic vegetation and wetland hydrology must be present, unless disturbed or problematic.		
<input checked="" type="checkbox"/> Thick Dark Surface (A12)			<input type="checkbox"/> Redox Dark Surface (F6)					
<input type="checkbox"/> Sandy Mucky Mineral (S1)			<input type="checkbox"/> Depleted Dark Surface (F7)					
<input type="checkbox"/> Sandy Gleyed Matrix (S4)			<input type="checkbox"/> Redox Depressions (F8)					
Restrictive Layer (if present):						Hydric Soils Present?		
Type: _____						Yes <input checked="" type="checkbox"/> No <input type="checkbox"/>		
Depth (inches): _____								
Remarks: 1 chroma								

HYDROLOGY

Wetland Hydrology Indicators:			
Primary Indicators (minimum of one required; check all that apply)		Secondary Indicators (2 or more required)	
<input type="checkbox"/> Surface Water (A1)	<input checked="" type="checkbox"/> Water-Stained Leaves (B9)	<input type="checkbox"/> Water-Stained Leaves (B9)	
<input checked="" type="checkbox"/> High Water Table (A2)	(except MLRA 1, 2, 4A, and 4B)	(MLRA 1, 2, 4A, and 4B)	
<input checked="" type="checkbox"/> Saturation (A3)	<input type="checkbox"/> Salt Crust (B11)	<input type="checkbox"/> Drainage Patterns (B10)	
<input type="checkbox"/> Water Marks (B1)	<input type="checkbox"/> Aquatic Invertebrates (B13)	<input type="checkbox"/> Dry-Season Water Table (C2)	
<input type="checkbox"/> Sediment Deposits (B2)	<input type="checkbox"/> Hydrogen Sulfide Odor (C1)	<input type="checkbox"/> Saturation Visible on Aerial Imagery (C9)	
<input type="checkbox"/> Drift Deposits (B3)	<input type="checkbox"/> Oxidized Rhizospheres along Living Roots (C3)	<input type="checkbox"/> Geomorphic Position (D2)	
<input type="checkbox"/> Algal Mat or Crust (B4)	<input type="checkbox"/> Presence of Reduced Iron (C4)	<input type="checkbox"/> Shallow Aquitard (D3)	
<input type="checkbox"/> Iron Deposits (B5)	<input type="checkbox"/> Recent Iron Reduction in Tilled Soils (C6)	<input type="checkbox"/> FAC-Neutral Test (D5)	
<input type="checkbox"/> Surface Soil Cracks (B6)	<input type="checkbox"/> Stunted or Stresses Plants (D1) (LRR A)	<input type="checkbox"/> Raised Ant Mounds (D6) (LRR A)	
<input type="checkbox"/> Inundation Visible on Aerial Imagery (B7)	<input type="checkbox"/> Other (Explain in Remarks)	<input type="checkbox"/> Frost-Heave Hummocks (D7)	
<input type="checkbox"/> Sparsely Vegetated Concave Surface (B8)			
Field Observations:		Wetland Hydrology Present?	
Surface Water Present?	Yes <input type="checkbox"/> No <input checked="" type="checkbox"/>	Depth (inches):	_____
Water Table Present?	Yes <input checked="" type="checkbox"/> No <input type="checkbox"/>	Depth (inches):	<u>6 inches</u>
Saturation Present? (includes capillary fringe)	Yes <input checked="" type="checkbox"/> No <input type="checkbox"/>	Depth (inches):	<u>Surface</u>
		Yes <input checked="" type="checkbox"/> No <input type="checkbox"/>	
Describe Recorded Data (stream gauge, monitoring well, aerial photos, previous inspections), if available:			
Remarks: Saturation and water table observed in sample plot			

WETLAND DETERMINATION DATA FORM – Western Mountains, Valleys, and Coast Region

Project Site: Sound Transit East Link Extension Project City/County: Bellevue/King Sampling Date: Feb. 6, 2013
 Applicant/Owner: Sound Transit State: WA Sampling Point: Mercer Slough JSP2U
 Investigator(s): C Douglas & J. Pursley Section, Township, Range: S5, T24N, R5E
 Landform (hillslope, terrace, etc.): Large wetland system - Mercer Slough Local relief (concave, convex, none): concave Slope (%): 0% to 4%
 Subregion (LRR): A Lat: 47.58N Long: 122.18W Datum: _____
 Soil Map Unit Name: Seattle Muck NWI classification: PFO, PSS, PEM
 Are climatic / hydrologic conditions on the site typical for this time of year? Yes No (If no, explain in Remarks.)
 Are Vegetation , Soil , or Hydrology , significantly disturbed? Are "Normal Circumstances" present? Yes No
 Are Vegetation , Soil , or Hydrology , naturally problematic? (If needed, explain any answers in Remarks.)

SUMMARY OF FINDINGS – Attach site map showing sampling point locations, transects, important features, etc.

Hydrophytic Vegetation Present?	Yes <input checked="" type="checkbox"/>	No <input type="checkbox"/>	Is the Sampled Area within a Wetland?		
Hydric Soil Present?	Yes <input type="checkbox"/>	No <input checked="" type="checkbox"/>		Yes <input type="checkbox"/>	No <input checked="" type="checkbox"/>
Wetland Hydrology Present?	Yes <input type="checkbox"/>	No <input checked="" type="checkbox"/>			
Remarks: Wetland Mercer Slough is a large wetland associated with the Mercer Slough and Lake Washington. Only a portion of the west boundary of wetland delineated as part of this investigation. Area west of wetland boundary includes roads and associated fill prisms. Wetland includes depressional, lake-fringe, riverine, and slope HGM classes.					

VEGETATION – Use scientific names of plants

Tree Stratum (Plot size: 30 foot radius)	Absolute % Cover	Dominant Species?	Indicator Status	Dominance Test Worksheet:																
1. <u><i>Alnus rubra</i></u>	20	no	FAC	Number of Dominant Species That Are OBL, FACW, or FAC: <u>2</u> (A) Total Number of Dominant Species Across All Strata: <u>3</u> (B) Percent of Dominant Species That Are OBL, FACW, or FAC: <u>67</u> (A/B)																
2. <u><i>Betula papyrifera</i></u>	90	yes	FAC																	
3. <u><i>Thuja plicata</i></u>	10	no	FAC																	
4. _____	_____	_____	_____																	
50% = <u>1</u> , 20% = <u>0</u>	100	= Total Cover		Prevalence Index worksheet: <table style="width: 100%; border: none;"> <tr> <td style="text-align: right;">Total % Cover of:</td> <td style="text-align: right;">Multiply by:</td> </tr> <tr> <td>OBL species _____</td> <td>x1 = _____</td> </tr> <tr> <td>FACW species _____</td> <td>x2 = _____</td> </tr> <tr> <td>FAC species _____</td> <td>x3 = _____</td> </tr> <tr> <td>FACU species _____</td> <td>x4 = _____</td> </tr> <tr> <td>UPL species _____</td> <td>x5 = _____</td> </tr> <tr> <td>Column Totals: _____ (A)</td> <td>_____ (B)</td> </tr> <tr> <td colspan="2" style="text-align: center;">Prevalence Index = B/A = _____</td> </tr> </table>	Total % Cover of:	Multiply by:	OBL species _____	x1 = _____	FACW species _____	x2 = _____	FAC species _____	x3 = _____	FACU species _____	x4 = _____	UPL species _____	x5 = _____	Column Totals: _____ (A)	_____ (B)	Prevalence Index = B/A = _____	
Total % Cover of:	Multiply by:																			
OBL species _____	x1 = _____																			
FACW species _____	x2 = _____																			
FAC species _____	x3 = _____																			
FACU species _____	x4 = _____																			
UPL species _____	x5 = _____																			
Column Totals: _____ (A)	_____ (B)																			
Prevalence Index = B/A = _____																				
<u>Sapling/Shrub Stratum (Plot size: 15 foot radius)</u>																				
1. <u><i>Rubus armeniacus</i></u>	30	yes	FACU																	
2. _____	_____	_____	_____																	
3. _____	_____	_____	_____																	
4. _____	_____	_____	_____																	
5. _____	_____	_____	_____																	
50% = <u>1</u> , 20% = <u>0</u>	30	= Total Cover																		
<u>Herb Stratum (Plot size: 3 foot radius)</u>																				
1. <u><i>Phalaris arundinacea</i></u>	50	yes	FACW	Hydrophytic Vegetation Indicators: <input type="checkbox"/> 1 – Rapid Test for Hydrophytic Vegetation <input type="checkbox"/> 2 - Dominance Test is >50% <input type="checkbox"/> 3 - Prevalence Index is $\leq 3.0^1$ <input type="checkbox"/> 4 - Morphological Adaptations ¹ (Provide supporting data in Remarks or on a separate sheet) <input type="checkbox"/> 5 - Wetland Non-Vascular Plants ¹ <input type="checkbox"/> Problematic Hydrophytic Vegetation ¹ (Explain) ¹ Indicators of hydric soil and wetland hydrology must be present, unless disturbed or problematic.																
2. _____	_____	_____	_____																	
3. _____	_____	_____	_____																	
4. _____	_____	_____	_____																	
5. _____	_____	_____	_____																	
6. _____	_____	_____	_____																	
7. _____	_____	_____	_____																	
8. _____	_____	_____	_____																	
9. _____	_____	_____	_____																	
10. _____	_____	_____	_____																	
11. _____	_____	_____	_____																	
50% = <u>1</u> , 20% = <u>0</u>	50	= Total Cover																		
<u>Woody Vine Stratum (Plot size: 3 foot radius)</u>																				
1. _____	_____	_____	_____																	
2. _____	_____	_____	_____																	
50% = _____, 20% = _____	0	= Total Cover																		
% Bare Ground in Herb Stratum <u>50</u>																				

Remarks: 67% dominant wetland vegetation per the Dominance Test

Hydrophytic Vegetation Present? Yes No

SOIL

Profile Description: (Describe to the depth needed to document the indicator or confirm the absence of indicators.)								
Depth (inches)	Matrix		Redox Features				Texture	Remarks
	Color (moist)	%	Color (moist)	%	Type ¹	Loc ²		
0 to 4	<u>10YR 3/2</u>	<u>100</u>	<u>None</u>	<u>None</u>	<u>None</u>	<u>None</u>	<u>Loam</u>	
4 to 18+	<u>10YR 3/4</u>	<u>100</u>	<u>None</u>	<u>None</u>	<u>None</u>	<u>None</u>	<u>Sandy loam</u>	
¹ Type: C= Concentration, D=Depletion, RM=Reduced Matrix, CS=Covered or Coated Sand Grains. ² Location: PL=Pore Lining, M=Matrix								
Hydric Soil Indicators: (Applicable to all LRRs, unless otherwise noted.)						Indicators for Problematic Hydric Soils³:		
<input type="checkbox"/> Histosol (A1)			<input type="checkbox"/> Sandy Redox (S5)			<input type="checkbox"/> 2 cm Muck (A10)		
<input type="checkbox"/> Histic Epipedon (A2)			<input type="checkbox"/> Stripped Matrix (S6)			<input type="checkbox"/> Red Parent Material (TF2)		
<input type="checkbox"/> Black Histic (A3)			<input type="checkbox"/> Loamy Mucky Mineral (F1) (except MLRA 1)			<input type="checkbox"/> Very Shallow Dark Surface (TF12)		
<input type="checkbox"/> Hydrogen Sulfide (A4)			<input type="checkbox"/> Loamy Gleyed Matrix (F2)			<input type="checkbox"/> Other (Explain in Remarks)		
<input type="checkbox"/> Depleted Below Dark Surface (A11)			<input type="checkbox"/> Depleted Matrix (F3)			³ Indicators of hydrophytic vegetation and wetland hydrology must be present, unless disturbed or problematic.		
<input type="checkbox"/> Thick Dark Surface (A12)			<input type="checkbox"/> Redox Dark Surface (F6)					
<input type="checkbox"/> Sandy Mucky Mineral (S1)			<input type="checkbox"/> Depleted Dark Surface (F7)					
<input type="checkbox"/> Sandy Gleyed Matrix (S4)			<input type="checkbox"/> Redox Depressions (F8)					
<input type="checkbox"/> Restrictive Layer (if present):			<input type="checkbox"/> Restrictive Layer (if present):					
Type: _____			Type: _____			Type: _____		
Depth (inches): _____			Depth (inches): _____			Depth (inches): _____		
Remarks: 2 chroma with no redox features						Hydric Soils Present? Yes <input type="checkbox"/> No <input checked="" type="checkbox"/>		

HYDROLOGY

Wetland Hydrology Indicators:			
Primary Indicators (minimum of one required; check all that apply)		Secondary Indicators (2 or more required)	
<input type="checkbox"/> Surface Water (A1)	<input type="checkbox"/> Water-Stained Leaves (B9)	<input type="checkbox"/> Water-Stained Leaves (B9)	
<input type="checkbox"/> High Water Table (A2)	(except MLRA 1, 2, 4A, and 4B)	(MLRA 1, 2, 4A, and 4B)	
<input type="checkbox"/> Saturation (A3)	<input type="checkbox"/> Salt Crust (B11)	<input type="checkbox"/> Drainage Patterns (B10)	
<input type="checkbox"/> Water Marks (B1)	<input type="checkbox"/> Aquatic Invertebrates (B13)	<input type="checkbox"/> Dry-Season Water Table (C2)	
<input type="checkbox"/> Sediment Deposits (B2)	<input type="checkbox"/> Hydrogen Sulfide Odor (C1)	<input type="checkbox"/> Saturation Visible on Aerial Imagery (C9)	
<input type="checkbox"/> Drift Deposits (B3)	<input type="checkbox"/> Oxidized Rhizospheres along Living Roots (C3)	<input type="checkbox"/> Geomorphic Position (D2)	
<input type="checkbox"/> Algal Mat or Crust (B4)	<input type="checkbox"/> Presence of Reduced Iron (C4)	<input type="checkbox"/> Shallow Aquitard (D3)	
<input type="checkbox"/> Iron Deposits (B5)	<input type="checkbox"/> Recent Iron Reduction in Tilled Soils (C6)	<input type="checkbox"/> FAC-Neutral Test (D5)	
<input type="checkbox"/> Surface Soil Cracks (B6)	<input type="checkbox"/> Stunted or Stresses Plants (D1) (LRR A)	<input type="checkbox"/> Raised Ant Mounds (D6) (LRR A)	
<input type="checkbox"/> Inundation Visible on Aerial Imagery (B7)	<input type="checkbox"/> Other (Explain in Remarks)	<input type="checkbox"/> Frost-Heave Hummocks (D7)	
<input type="checkbox"/> Sparsely Vegetated Concave Surface (B8)			
Field Observations:		Wetland Hydrology Present? Yes <input type="checkbox"/> No <input checked="" type="checkbox"/>	
Surface Water Present? Yes <input type="checkbox"/> No <input checked="" type="checkbox"/>	Depth (inches): _____		
Water Table Present? Yes <input type="checkbox"/> No <input checked="" type="checkbox"/>	Depth (inches): _____		
Saturation Present? (includes capillary fringe) Yes <input type="checkbox"/> No <input checked="" type="checkbox"/>	Depth (inches): _____		
Describe Recorded Data (stream gauge, monitoring well, aerial photos, previous inspections), if available:			
Remarks: No saturation or water table observed in sample plot			

WETLAND DETERMINATION DATA FORM – Western Mountains, Valleys, and Coast Region

Project Site: Sound Transit East Link Extension Project City/County: Bellevue/King Sampling Date: Feb. 6, 2013
 Applicant/Owner: Sound Transit State: WA Sampling Point: Mercer Slough SP3W
 Investigator(s): C Douglas & J. Pursley Section, Township, Range: S5, T24N, R5E
 Landform (hillslope, terrace, etc.): Large wetland system - Mercer Slough Local relief (concave, convex, none): concave Slope (%): 0% to 4%
 Subregion (LRR): A Lat: 47.58N Long: 122.18W Datum: _____
 Soil Map Unit Name: Seattle Muck NWI classification: PFO, PSS, PEM
 Are climatic / hydrologic conditions on the site typical for this time of year? Yes No (If no, explain in Remarks.)
 Are Vegetation , Soil , or Hydrology , significantly disturbed? Are "Normal Circumstances" present? Yes No
 Are Vegetation , Soil , or Hydrology , naturally problematic? (If needed, explain any answers in Remarks.)

SUMMARY OF FINDINGS – Attach site map showing sampling point locations, transects, important features, etc.

Hydrophytic Vegetation Present?	Yes <input checked="" type="checkbox"/>	No <input type="checkbox"/>	Is the Sampled Area within a Wetland?	Yes <input checked="" type="checkbox"/>	No <input type="checkbox"/>
Hydric Soil Present?	Yes <input checked="" type="checkbox"/>	No <input type="checkbox"/>		Yes <input checked="" type="checkbox"/>	No <input type="checkbox"/>
Wetland Hydrology Present?	Yes <input checked="" type="checkbox"/>	No <input type="checkbox"/>		Yes <input checked="" type="checkbox"/>	No <input type="checkbox"/>
Remarks: Wetland Mercer Slough is a large wetland associated with the Mercer Slough and Lake Washington. Only a portion of the west boundary of wetland delineated as part of this investigation. Area west of wetland boundary includes roads and associated fill prisms. Wetland includes depressional, lake-fringe, riverine, and slope HGM classes.					

VEGETATION – Use scientific names of plants

Tree Stratum (Plot size: 30 foot radius)	Absolute % Cover	Dominant Species?	Indicator Status	Dominance Test Worksheet:																
1. <u><i>Alnus rubra</i></u>	70	yes	FAC	Number of Dominant Species That Are OBL, FACW, or FAC: <u>5</u> (A) Total Number of Dominant Species Across All Strata: <u>5</u> (B) Percent of Dominant Species That Are OBL, FACW, or FAC: <u>100</u> (A/B)																
2. <u><i>Betula papyrifera</i></u>	5	no	FAC																	
3. <u><i>Picea sitchensis</i></u>	30	yes	FAC																	
4. <u><i>Salix hookeriana</i></u>	15	no	FACW																	
50% = 1, 20% = 2	100	= Total Cover		Prevalence Index worksheet: <table style="width: 100%; border: none;"> <tr> <td style="text-align: center;">Total % Cover of:</td> <td style="text-align: center;">Multiply by:</td> </tr> <tr> <td>OBL species _____</td> <td>x1 = _____</td> </tr> <tr> <td>FACW species _____</td> <td>x2 = _____</td> </tr> <tr> <td>FAC species _____</td> <td>x3 = _____</td> </tr> <tr> <td>FACU species _____</td> <td>x4 = _____</td> </tr> <tr> <td>UPL species _____</td> <td>x5 = _____</td> </tr> <tr> <td>Column Totals: _____ (A)</td> <td>_____ (B)</td> </tr> <tr> <td colspan="2" style="text-align: center;">Prevalence Index = B/A = _____</td> </tr> </table>	Total % Cover of:	Multiply by:	OBL species _____	x1 = _____	FACW species _____	x2 = _____	FAC species _____	x3 = _____	FACU species _____	x4 = _____	UPL species _____	x5 = _____	Column Totals: _____ (A)	_____ (B)	Prevalence Index = B/A = _____	
Total % Cover of:	Multiply by:																			
OBL species _____	x1 = _____																			
FACW species _____	x2 = _____																			
FAC species _____	x3 = _____																			
FACU species _____	x4 = _____																			
UPL species _____	x5 = _____																			
Column Totals: _____ (A)	_____ (B)																			
Prevalence Index = B/A = _____																				
Sapling/Shrub Stratum (Plot size: 15 foot radius)																				
1. <u><i>Rubus spectabilis</i></u>	40	yes	FAC																	
2. _____	_____	_____	_____																	
3. _____	_____	_____	_____																	
4. _____	_____	_____	_____																	
5. _____	_____	_____	_____																	
50% = 1, 20% = 0	40	= Total Cover																		
Herb Stratum (Plot size: 3 foot radius)																				
1. <u><i>Athyrium filix-femina</i></u>	15	yes	FAC																	
2. <u><i>Carex obnupta</i></u>	20	yes	OBL																	
3. _____	_____	_____	_____																	
4. _____	_____	_____	_____																	
5. _____	_____	_____	_____																	
6. _____	_____	_____	_____																	
7. _____	_____	_____	_____																	
8. _____	_____	_____	_____																	
9. _____	_____	_____	_____																	
10. _____	_____	_____	_____																	
11. _____	_____	_____	_____																	
50% = 1, 20% = 1	35	= Total Cover																		
Woody Vine Stratum (Plot size: 3 foot radius)																				
1. _____	_____	_____	_____																	
2. _____	_____	_____	_____																	
50% = _____, 20% = _____	0	= Total Cover																		
<table style="width: 100%; border: none;"> <tr> <td style="width: 35%;">Hydrophytic Vegetation Present?</td> <td style="width: 10%;">Yes</td> <td style="width: 10%;"><input checked="" type="checkbox"/></td> <td style="width: 10%;">No</td> <td style="width: 10%;"><input type="checkbox"/></td> </tr> </table>				Hydrophytic Vegetation Present?	Yes	<input checked="" type="checkbox"/>	No	<input type="checkbox"/>												
Hydrophytic Vegetation Present?	Yes	<input checked="" type="checkbox"/>	No	<input type="checkbox"/>																
Hydrophytic Vegetation Indicators: <input type="checkbox"/> 1 – Rapid Test for Hydrophytic Vegetation <input checked="" type="checkbox"/> 2 - Dominance Test is >50% <input type="checkbox"/> 3 - Prevalence Index is $\leq 3.0^1$ <input type="checkbox"/> 4 - Morphological Adaptations ¹ (Provide supporting data in Remarks or on a separate sheet) <input type="checkbox"/> 5 - Wetland Non-Vascular Plants ¹ <input type="checkbox"/> Problematic Hydrophytic Vegetation ¹ (Explain) ¹ Indicators of hydric soil and wetland hydrology must be present, unless disturbed or problematic.																				
% Bare Ground in Herb Stratum <u>65</u>																				

Remarks: 100% dominant wetland vegetation per the Dominance Test

SOIL

Profile Description: (Describe to the depth needed to document the indicator or confirm the absence of indicators.)

Depth (inches)	Matrix		Redox Features				Texture	Remarks
	Color (moist)	%	Color (moist)	%	Type ¹	Loc ²		
0 to 6	10YR 2/1	100	None	None	None	None	Loam	
6 to 9	10YR 2/1	100	None	None	None	None	Silt loam	
9 to 12	10YR 2/2	100	None	None	None	None	Silt	w/dense organic material
12 to 18+	10YR 3/1	100	None	None	None	None	Sandy silt	
_____	_____	_____	_____	_____	_____	_____	_____	_____
_____	_____	_____	_____	_____	_____	_____	_____	_____
_____	_____	_____	_____	_____	_____	_____	_____	_____
_____	_____	_____	_____	_____	_____	_____	_____	_____

¹Type: C= Concentration, D=Depletion, RM=Reduced Matrix, CS=Covered or Coated Sand Grains. ²Location: PL=Pore Lining, M=Matrix

Hydric Soil Indicators: (Applicable to all LRRs, unless otherwise noted.)		Indicators for Problematic Hydric Soils³:	
<input type="checkbox"/> Histosol (A1)	<input type="checkbox"/> Sandy Redox (S5)	<input type="checkbox"/> 2 cm Muck (A10)	
<input type="checkbox"/> Histic Epipedon (A2)	<input type="checkbox"/> Stripped Matrix (S6)	<input type="checkbox"/> Red Parent Material (TF2)	
<input type="checkbox"/> Black Histic (A3)	<input type="checkbox"/> Loamy Mucky Mineral (F1) (except MLRA 1)	<input type="checkbox"/> Very Shallow Dark Surface (TF12)	
<input type="checkbox"/> Hydrogen Sulfide (A4)	<input type="checkbox"/> Loamy Gleyed Matrix (F2)	<input type="checkbox"/> Other (Explain in Remarks)	
<input type="checkbox"/> Depleted Below Dark Surface (A11)	<input type="checkbox"/> Depleted Matrix (F3)		
<input checked="" type="checkbox"/> Thick Dark Surface (A12)	<input type="checkbox"/> Redox Dark Surface (F6)		
<input checked="" type="checkbox"/> Sandy Mucky Mineral (S1)	<input type="checkbox"/> Depleted Dark Surface (F7)		
<input type="checkbox"/> Sandy Gleyed Matrix (S4)	<input type="checkbox"/> Redox Depressions (F8)		

³Indicators of hydrophytic vegetation and wetland hydrology must be present, unless disturbed or problematic.

Restrictive Layer (if present): Type: _____ Depth (inches): _____	Hydric Soils Present? Yes <input checked="" type="checkbox"/> No <input type="checkbox"/>
--	--

Remarks: 1 chroma

HYDROLOGY

Wetland Hydrology Indicators:	
Primary Indicators (minimum of one required; check all that apply)	Secondary Indicators (2 or more required)
<input type="checkbox"/> Surface Water (A1)	<input checked="" type="checkbox"/> Water-Stained Leaves (B9)
<input checked="" type="checkbox"/> High Water Table (A2)	(except MLRA 1, 2, 4A, and 4B)
<input checked="" type="checkbox"/> Saturation (A3)	<input type="checkbox"/> Salt Crust (B11)
<input type="checkbox"/> Water Marks (B1)	<input type="checkbox"/> Aquatic Invertebrates (B13)
<input type="checkbox"/> Sediment Deposits (B2)	<input type="checkbox"/> Hydrogen Sulfide Odor (C1)
<input type="checkbox"/> Drift Deposits (B3)	<input type="checkbox"/> Oxidized Rhizospheres along Living Roots (C3)
<input type="checkbox"/> Algal Mat or Crust (B4)	<input type="checkbox"/> Presence of Reduced Iron (C4)
<input type="checkbox"/> Iron Deposits (B5)	<input type="checkbox"/> Recent Iron Reduction in Tilled Soils (C6)
<input type="checkbox"/> Surface Soil Cracks (B6)	<input type="checkbox"/> Stunted or Stresses Plants (D1) (LRR A)
<input type="checkbox"/> Inundation Visible on Aerial Imagery (B7)	<input type="checkbox"/> Other (Explain in Remarks)
<input type="checkbox"/> Sparsely Vegetated Concave Surface (B8)	<input type="checkbox"/> Water-Stained Leaves (B9)
	(MLRA 1, 2, 4A, and 4B)
	<input type="checkbox"/> Drainage Patterns (B10)
	<input type="checkbox"/> Dry-Season Water Table (C2)
	<input type="checkbox"/> Saturation Visible on Aerial Imagery (C9)
	<input type="checkbox"/> Geomorphic Position (D2)
	<input type="checkbox"/> Shallow Aquitard (D3)
	<input type="checkbox"/> FAC-Neutral Test (D5)
	<input type="checkbox"/> Raised Ant Mounds (D6) (LRR A)
	<input type="checkbox"/> Frost-Heave Hummocks (D7)

Field Observations:	Wetland Hydrology Present? Yes <input checked="" type="checkbox"/> No <input type="checkbox"/>
Surface Water Present? Yes <input type="checkbox"/> No <input checked="" type="checkbox"/> Depth (inches): _____	
Water Table Present? Yes <input checked="" type="checkbox"/> No <input type="checkbox"/> Depth (inches): <u>11 inches</u>	
Saturation Present? (includes capillary fringe) Yes <input checked="" type="checkbox"/> No <input type="checkbox"/> Depth (inches): <u>Surface</u>	

Describe Recorded Data (stream gauge, monitoring well, aerial photos, previous inspections), if available:

Remarks: Saturation and water table observed in sample plot

WETLAND DETERMINATION DATA FORM – Western Mountains, Valleys, and Coast Region

Project Site: Sound Transit East Link Extension Project City/County: Bellevue/King Sampling Date: Feb. 6, 2013
 Applicant/Owner: Sound Transit State: WA Sampling Point: Mercer Slough SP4U
 Investigator(s): C Douglas & J. Pursley Section, Township, Range: S5, T24N, R5E
 Landform (hillslope, terrace, etc.): Large wetland system - Mercer Slough Local relief (concave, convex, none): concave Slope (%): 0% to 4%
 Subregion (LRR): A Lat: 47.58N Long: 122.18W Datum: _____
 Soil Map Unit Name: Seattle Muck NWI classification: PFO, PSS, PEM
 Are climatic / hydrologic conditions on the site typical for this time of year? Yes No (If no, explain in Remarks.)
 Are Vegetation , Soil , or Hydrology , significantly disturbed? Are "Normal Circumstances" present? Yes No
 Are Vegetation , Soil , or Hydrology , naturally problematic? (If needed, explain any answers in Remarks.)

SUMMARY OF FINDINGS – Attach site map showing sampling point locations, transects, important features, etc.

Hydrophytic Vegetation Present?	Yes <input type="checkbox"/>	No <input checked="" type="checkbox"/>	Is the Sampled Area within a Wetland?	Yes <input type="checkbox"/>	No <input checked="" type="checkbox"/>
Hydric Soil Present?	Yes <input type="checkbox"/>	No <input checked="" type="checkbox"/>		Yes <input type="checkbox"/>	No <input checked="" type="checkbox"/>
Wetland Hydrology Present?	Yes <input type="checkbox"/>	No <input checked="" type="checkbox"/>		Yes <input type="checkbox"/>	No <input checked="" type="checkbox"/>
Remarks: Wetland Mercer Slough is a large wetland associated with the Mercer Slough and Lake Washington. Only a portion of the west boundary of wetland delineated as part of this investigation. Area west of wetland boundary includes roads and associated fill prisms. Wetland includes depressionnal, lake-fringe, riverine, and slope HGM classes.					

VEGETATION – Use scientific names of plants

Tree Stratum (Plot size: 30 foot radius)	Absolute % Cover	Dominant Species?	Indicator Status	Dominance Test Worksheet:																								
1. <u><i>Alnus rubra</i></u>	<u>20</u>	<u>yes</u>	<u>FAC</u>	Number of Dominant Species That Are OBL, FACW, or FAC: <u>2</u> (A) Total Number of Dominant Species Across All Strata: <u>5</u> (B) Percent of Dominant Species That Are OBL, FACW, or FAC: <u>40</u> (A/B)																								
2. <u><i>Pseudotsuga menziesii</i></u>	<u>80</u>	<u>yes</u>	<u>FACU</u>																									
3. _____	_____	_____	_____																									
4. _____	_____	_____	_____																									
50% = <u>1</u> , 20% = <u>1</u>	<u>100</u>	= Total Cover																										
Sapling/Shrub Stratum (Plot size: 15 foot radius)				Prevalence Index worksheet: <table style="width: 100%; border-collapse: collapse;"> <tr> <td style="width: 60%;"></td> <td style="text-align: center;"><u>Total % Cover of:</u></td> <td style="text-align: center;"><u>Multiply by:</u></td> </tr> <tr> <td>OBL species</td> <td style="text-align: center;">_____</td> <td style="text-align: center;">x1 = _____</td> </tr> <tr> <td>FACW species</td> <td style="text-align: center;">_____</td> <td style="text-align: center;">x2 = _____</td> </tr> <tr> <td>FAC species</td> <td style="text-align: center;">_____</td> <td style="text-align: center;">x3 = _____</td> </tr> <tr> <td>FACU species</td> <td style="text-align: center;">_____</td> <td style="text-align: center;">x4 = _____</td> </tr> <tr> <td>UPL species</td> <td style="text-align: center;">_____</td> <td style="text-align: center;">x5 = _____</td> </tr> <tr> <td>Column Totals:</td> <td style="text-align: center;">_____ (A)</td> <td style="text-align: center;">_____ (B)</td> </tr> <tr> <td colspan="3" style="text-align: center;">Prevalence Index = B/A = _____</td> </tr> </table>		<u>Total % Cover of:</u>	<u>Multiply by:</u>	OBL species	_____	x1 = _____	FACW species	_____	x2 = _____	FAC species	_____	x3 = _____	FACU species	_____	x4 = _____	UPL species	_____	x5 = _____	Column Totals:	_____ (A)	_____ (B)	Prevalence Index = B/A = _____		
	<u>Total % Cover of:</u>	<u>Multiply by:</u>																										
OBL species	_____	x1 = _____																										
FACW species	_____	x2 = _____																										
FAC species	_____	x3 = _____																										
FACU species	_____	x4 = _____																										
UPL species	_____	x5 = _____																										
Column Totals:	_____ (A)	_____ (B)																										
Prevalence Index = B/A = _____																												
1. <u><i>Gaultheria shallon</i></u>	<u>40</u>	<u>yes</u>	<u>FACU</u>																									
2. <u><i>Holodiscus discolor</i></u>	<u>20</u>	<u>no</u>	<u>UPL</u>																									
3. <u><i>Rosa gymnocarpa</i></u>	<u>35</u>	<u>yes</u>	<u>FACU</u>																									
4. <u><i>Rubus spectabilis</i></u>	<u>30</u>	<u>yes</u>	<u>FAC</u>																									
5. _____	_____	_____	_____																									
50% = <u>0</u> , 20% = <u>3</u>	<u>100</u>	= Total Cover																										
Herb Stratum (Plot size: 3 foot radius)																												
1. _____	_____	_____	_____																									
2. _____	_____	_____	_____																									
3. _____	_____	_____	_____																									
4. _____	_____	_____	_____																									
5. _____	_____	_____	_____																									
6. _____	_____	_____	_____																									
7. _____	_____	_____	_____																									
8. _____	_____	_____	_____																									
9. _____	_____	_____	_____																									
10. _____	_____	_____	_____																									
11. _____	_____	_____	_____																									
50% = <u>0</u> , 20% = <u>0</u>	<u>0</u>	= Total Cover																										
Woody Vine Stratum (Plot size: 3 foot radius)																												
1. _____	_____	_____	_____																									
2. _____	_____	_____	_____																									
50% = _____, 20% = _____	<u>0</u>	= Total Cover																										
% Bare Ground in Herb Stratum <u>100</u>																												
Hydrophytic Vegetation Indicators: <input type="checkbox"/> 1 – Rapid Test for Hydrophytic Vegetation <input type="checkbox"/> 2 - Dominance Test is >50% <input type="checkbox"/> 3 - Prevalence Index is $\leq 3.0^1$ <input type="checkbox"/> 4 - Morphological Adaptations ¹ (Provide supporting data in Remarks or on a separate sheet) <input type="checkbox"/> 5 - Wetland Non-Vascular Plants ¹ <input type="checkbox"/> Problematic Hydrophytic Vegetation ¹ (Explain)																												
¹ Indicators of hydric soil and wetland hydrology must be present, unless disturbed or problematic.																												
Hydrophytic Vegetation Present? Yes <input type="checkbox"/> No <input checked="" type="checkbox"/>																												

Remarks: 40% dominant wetland vegetation per the Dominance Test

SOIL

Profile Description: (Describe to the depth needed to document the indicator or confirm the absence of indicators.)

Depth (inches)	Matrix		Redox Features				Texture	Remarks
	Color (moist)	%	Color (moist)	%	Type ¹	Loc ²		
<u>0 to 4</u>	<u>10YR 2/2</u>	<u>100</u>	<u>None</u>	<u>None</u>	<u>None</u>	<u>None</u>	<u>Sandy loam</u>	
<u>4 to 18+</u>	<u>10YR 3/6</u>	<u>100</u>	<u>None</u>	<u>None</u>	<u>None</u>	<u>None</u>	<u>Sandy loam</u>	
_____	_____	_____	_____	_____	_____	_____	_____	_____
_____	_____	_____	_____	_____	_____	_____	_____	_____
_____	_____	_____	_____	_____	_____	_____	_____	_____
_____	_____	_____	_____	_____	_____	_____	_____	_____

¹Type: C= Concentration, D=Depletion, RM=Reduced Matrix, CS=Covered or Coated Sand Grains. ²Location: PL=Pore Lining, M=Matrix

Hydric Soil Indicators: (Applicable to all LRRs, unless otherwise noted.)		Indicators for Problematic Hydric Soils³:	
<input type="checkbox"/> Histosol (A1)	<input type="checkbox"/> Sandy Redox (S5)	<input type="checkbox"/> 2 cm Muck (A10)	
<input type="checkbox"/> Histic Epipedon (A2)	<input type="checkbox"/> Stripped Matrix (S6)	<input type="checkbox"/> Red Parent Material (TF2)	
<input type="checkbox"/> Black Histic (A3)	<input type="checkbox"/> Loamy Mucky Mineral (F1) (except MLRA 1)	<input type="checkbox"/> Very Shallow Dark Surface (TF12)	
<input type="checkbox"/> Hydrogen Sulfide (A4)	<input type="checkbox"/> Loamy Gleyed Matrix (F2)	<input type="checkbox"/> Other (Explain in Remarks)	
<input type="checkbox"/> Depleted Below Dark Surface (A11)	<input type="checkbox"/> Depleted Matrix (F3)		
<input type="checkbox"/> Thick Dark Surface (A12)	<input type="checkbox"/> Redox Dark Surface (F6)		
<input type="checkbox"/> Sandy Mucky Mineral (S1)	<input type="checkbox"/> Depleted Dark Surface (F7)		
<input type="checkbox"/> Sandy Gleyed Matrix (S4)	<input type="checkbox"/> Redox Depressions (F8)		

³Indicators of hydrophytic vegetation and wetland hydrology must be present, unless disturbed or problematic.

Restrictive Layer (if present): Type: _____ Depth (inches): _____	Hydric Soils Present? Yes <input type="checkbox"/> No <input checked="" type="checkbox"/>
--	--

Remarks: 2 & 6 chromas with no redox features

HYDROLOGY

Wetland Hydrology Indicators:

Primary Indicators (minimum of one required; check all that apply)		Secondary Indicators (2 or more required)
<input type="checkbox"/> Surface Water (A1)	<input type="checkbox"/> Water-Stained Leaves (B9)	<input type="checkbox"/> Water-Stained Leaves (B9)
<input type="checkbox"/> High Water Table (A2)	(except MLRA 1, 2, 4A, and 4B)	(MLRA 1, 2, 4A, and 4B)
<input type="checkbox"/> Saturation (A3)	<input type="checkbox"/> Salt Crust (B11)	<input type="checkbox"/> Drainage Patterns (B10)
<input type="checkbox"/> Water Marks (B1)	<input type="checkbox"/> Aquatic Invertebrates (B13)	<input type="checkbox"/> Dry-Season Water Table (C2)
<input type="checkbox"/> Sediment Deposits (B2)	<input type="checkbox"/> Hydrogen Sulfide Odor (C1)	<input type="checkbox"/> Saturation Visible on Aerial Imagery (C9)
<input type="checkbox"/> Drift Deposits (B3)	<input type="checkbox"/> Oxidized Rhizospheres along Living Roots (C3)	<input type="checkbox"/> Geomorphic Position (D2)
<input type="checkbox"/> Algal Mat or Crust (B4)	<input type="checkbox"/> Presence of Reduced Iron (C4)	<input type="checkbox"/> Shallow Aquitard (D3)
<input type="checkbox"/> Iron Deposits (B5)	<input type="checkbox"/> Recent Iron Reduction in Tilled Soils (C6)	<input type="checkbox"/> FAC-Neutral Test (D5)
<input type="checkbox"/> Surface Soil Cracks (B6)	<input type="checkbox"/> Stunted or Stresses Plants (D1) (LRR A)	<input type="checkbox"/> Raised Ant Mounds (D6) (LRR A)
<input type="checkbox"/> Inundation Visible on Aerial Imagery (B7)	<input type="checkbox"/> Other (Explain in Remarks)	<input type="checkbox"/> Frost-Heave Hummocks (D7)
<input type="checkbox"/> Sparsely Vegetated Concave Surface (B8)		

Field Observations: Surface Water Present? Yes <input type="checkbox"/> No <input checked="" type="checkbox"/> Depth (inches): _____ Water Table Present? Yes <input type="checkbox"/> No <input checked="" type="checkbox"/> Depth (inches): _____ Saturation Present? (includes capillary fringe) Yes <input type="checkbox"/> No <input checked="" type="checkbox"/> Depth (inches): _____	Wetland Hydrology Present? Yes <input type="checkbox"/> No <input checked="" type="checkbox"/>
---	---

Describe Recorded Data (stream gauge, monitoring well, aerial photos, previous inspections), if available:

Remarks: No saturation or water table observed in sample plot

WETLAND DETERMINATION DATA FORM – Western Mountains, Valleys, and Coast Region

Project Site: Sound Transit East Link Extension Project City/County: Bellevue/King Sampling Date: Feb. 6, 2013
 Applicant/Owner: Sound Transit State: WA Sampling Point: Mercer Slough SP5W
 Investigator(s): C Douglas & J. Pursley Section, Township, Range: S5, T24N, R5E
 Landform (hillslope, terrace, etc.): Large wetland system - Mercer Slough Local relief (concave, convex, none): concave Slope (%): 0% to 4%
 Subregion (LRR): A Lat: 47.58N Long: 122.18W Datum: _____
 Soil Map Unit Name: Seattle Muck NWI classification: PFO, PSS, PEM
 Are climatic / hydrologic conditions on the site typical for this time of year? Yes No (If no, explain in Remarks.)
 Are Vegetation , Soil , or Hydrology , significantly disturbed? Are "Normal Circumstances" present? Yes No
 Are Vegetation , Soil , or Hydrology , naturally problematic? (If needed, explain any answers in Remarks.)

SUMMARY OF FINDINGS – Attach site map showing sampling point locations, transects, important features, etc.

Hydrophytic Vegetation Present?	Yes <input checked="" type="checkbox"/>	No <input type="checkbox"/>	Is the Sampled Area within a Wetland?	Yes <input checked="" type="checkbox"/>	No <input type="checkbox"/>
Hydric Soil Present?	Yes <input checked="" type="checkbox"/>	No <input type="checkbox"/>		Yes <input checked="" type="checkbox"/>	No <input type="checkbox"/>
Wetland Hydrology Present?	Yes <input checked="" type="checkbox"/>	No <input type="checkbox"/>			
Remarks: Wetland Mercer Slough is a large wetland associated with the Mercer Slough and Lake Washington. Only a portion of the west boundary of wetland delineated as part of this investigation. Area west of wetland boundary includes roads and associated fill prisms. Wetland includes depressional, lake-fringe, riverine, and slope HGM classes.					

VEGETATION – Use scientific names of plants

Tree Stratum (Plot size: 30 foot radius)	Absolute % Cover	Dominant Species?	Indicator Status	Dominance Test Worksheet:			
1. <u>Salix lasiandra</u>	30	yes	FACW	Number of Dominant Species That Are OBL, FACW, or FAC:	2 (A)		
2. <u>Thuja plicata</u>	15	yes	FAC	Total Number of Dominant Species Across All Strata:	2 (B)		
3. _____	_____	_____	_____	Percent of Dominant Species That Are OBL, FACW, or FAC:	100 (A/B)		
4. _____	_____	_____	_____				
50% = 0, 20% = 1	45	= Total Cover					
Sapling/Shrub Stratum (Plot size: 15 foot radius)				Prevalence Index worksheet:			
1. <u>Rubus spectabilis</u>	80	yes	FAC	Total % Cover of:	Multiply by:		
2. _____	_____	_____	_____	OBL species _____	x1 = _____		
3. _____	_____	_____	_____	FACW species _____	x2 = _____		
4. _____	_____	_____	_____	FAC species _____	x3 = _____		
5. _____	_____	_____	_____	FACU species _____	x4 = _____		
50% = 1, 20% = 0	80	= Total Cover		UPL species _____	x5 = _____		
Herb Stratum (Plot size: 3 foot radius)				Column Totals: _____ (A)	_____ (B)		
1. _____	_____	_____	_____	Prevalence Index = B/A = _____			
2. _____	_____	_____	_____	Hydrophytic Vegetation Indicators: <input type="checkbox"/> 1 – Rapid Test for Hydrophytic Vegetation <input checked="" type="checkbox"/> 2 - Dominance Test is >50% <input type="checkbox"/> 3 - Prevalence Index is $\leq 3.0^1$ <input type="checkbox"/> 4 - Morphological Adaptations ¹ (Provide supporting data in Remarks or on a separate sheet) <input type="checkbox"/> 5 - Wetland Non-Vascular Plants ¹ <input type="checkbox"/> Problematic Hydrophytic Vegetation ¹ (Explain) ¹ Indicators of hydric soil and wetland hydrology must be present, unless disturbed or problematic.			
3. _____	_____	_____	_____				
4. _____	_____	_____	_____				
5. _____	_____	_____	_____				
6. _____	_____	_____	_____				
7. _____	_____	_____	_____				
8. _____	_____	_____	_____				
9. _____	_____	_____	_____				
10. _____	_____	_____	_____				
11. _____	_____	_____	_____				
50% = 0, 20% = 0	0	= Total Cover					
Woody Vine Stratum (Plot size: 3 foot radius)				Hydrophytic Vegetation Present?			
1. _____	_____	_____	_____			Yes <input checked="" type="checkbox"/>	No <input type="checkbox"/>
2. _____	_____	_____	_____				
50% = _____, 20% = _____	0	= Total Cover					
% Bare Ground in Herb Stratum <u>100</u>							

Remarks: 100% dominant wetland vegetation per the Dominance Test

SOIL

Profile Description: (Describe to the depth needed to document the indicator or confirm the absence of indicators.)								
Depth (inches)	Matrix		Redox Features				Texture	Remarks
	Color (moist)	%	Color (moist)	%	Type ¹	Loc ²		
0 to 7	10YR 2/1	100	None	None	None	None	Silt loam	
7 to 10	10YR 2/1	100	None	None	None	None	Silt	w/organic material
10 to 18+	10YR 2/1	100	None	None	None	None	Silt	w/dense organic material
_____	_____	_____	_____	_____	_____	_____	_____	_____
_____	_____	_____	_____	_____	_____	_____	_____	_____
_____	_____	_____	_____	_____	_____	_____	_____	_____
_____	_____	_____	_____	_____	_____	_____	_____	_____
_____	_____	_____	_____	_____	_____	_____	_____	_____

¹Type: C= Concentration, D=Depletion, RM=Reduced Matrix, CS=Covered or Coated Sand Grains. ²Location: PL=Pore Lining, M=Matrix

Hydric Soil Indicators: (Applicable to all LRRs, unless otherwise noted.)			Indicators for Problematic Hydric Soils³:		
<input type="checkbox"/> Histosol (A1)	<input type="checkbox"/> Sandy Redox (S5)	<input type="checkbox"/> 2 cm Muck (A10)			
<input type="checkbox"/> Histic Epipedon (A2)	<input type="checkbox"/> Stripped Matrix (S6)	<input type="checkbox"/> Red Parent Material (TF2)			
<input type="checkbox"/> Black Histic (A3)	<input type="checkbox"/> Loamy Mucky Mineral (F1) (except MLRA 1)	<input type="checkbox"/> Very Shallow Dark Surface (TF12)			
<input type="checkbox"/> Hydrogen Sulfide (A4)	<input type="checkbox"/> Loamy Gleyed Matrix (F2)	<input type="checkbox"/> Other (Explain in Remarks)			
<input type="checkbox"/> Depleted Below Dark Surface (A11)	<input type="checkbox"/> Depleted Matrix (F3)				
<input checked="" type="checkbox"/> Thick Dark Surface (A12)	<input type="checkbox"/> Redox Dark Surface (F6)				
<input type="checkbox"/> Sandy Mucky Mineral (S1)	<input type="checkbox"/> Depleted Dark Surface (F7)				
<input type="checkbox"/> Sandy Gleyed Matrix (S4)	<input type="checkbox"/> Redox Depressions (F8)				

³Indicators of hydrophytic vegetation and wetland hydrology must be present, unless disturbed or problematic.

Restrictive Layer (if present):		Hydric Soils Present? Yes <input checked="" type="checkbox"/> No <input type="checkbox"/>
Type: _____	Depth (inches): _____	

Remarks: 1 chroma

HYDROLOGY

Wetland Hydrology Indicators:			
Primary Indicators (minimum of one required; check all that apply)		Secondary Indicators (2 or more required)	
<input type="checkbox"/> Surface Water (A1)	<input type="checkbox"/> Water-Stained Leaves (B9)	<input type="checkbox"/> Water-Stained Leaves (B9)	
<input type="checkbox"/> High Water Table (A2)	(except MLRA 1, 2, 4A, and 4B)	(MLRA 1, 2, 4A, and 4B)	
<input checked="" type="checkbox"/> Saturation (A3)	<input type="checkbox"/> Salt Crust (B11)	<input type="checkbox"/> Drainage Patterns (B10)	
<input type="checkbox"/> Water Marks (B1)	<input type="checkbox"/> Aquatic Invertebrates (B13)	<input type="checkbox"/> Dry-Season Water Table (C2)	
<input type="checkbox"/> Sediment Deposits (B2)	<input type="checkbox"/> Hydrogen Sulfide Odor (C1)	<input type="checkbox"/> Saturation Visible on Aerial Imagery (C9)	
<input type="checkbox"/> Drift Deposits (B3)	<input type="checkbox"/> Oxidized Rhizospheres along Living Roots (C3)	<input type="checkbox"/> Geomorphic Position (D2)	
<input type="checkbox"/> Algal Mat or Crust (B4)	<input type="checkbox"/> Presence of Reduced Iron (C4)	<input type="checkbox"/> Shallow Aquitard (D3)	
<input type="checkbox"/> Iron Deposits (B5)	<input type="checkbox"/> Recent Iron Reduction in Tilled Soils (C6)	<input type="checkbox"/> FAC-Neutral Test (D5)	
<input type="checkbox"/> Surface Soil Cracks (B6)	<input type="checkbox"/> Stunted or Stresses Plants (D1) (LRR A)	<input type="checkbox"/> Raised Ant Mounds (D6) (LRR A)	
<input type="checkbox"/> Inundation Visible on Aerial Imagery (B7)	<input type="checkbox"/> Other (Explain in Remarks)	<input type="checkbox"/> Frost-Heave Hummocks (D7)	
<input type="checkbox"/> Sparsely Vegetated Concave Surface (B8)			

Field Observations:		Wetland Hydrology Present? Yes <input checked="" type="checkbox"/> No <input type="checkbox"/>
Surface Water Present? Yes <input type="checkbox"/> No <input checked="" type="checkbox"/>	Depth (inches): _____	
Water Table Present? Yes <input type="checkbox"/> No <input checked="" type="checkbox"/>	Depth (inches): _____	
Saturation Present? (includes capillary fringe) Yes <input checked="" type="checkbox"/> No <input type="checkbox"/>	Depth (inches): <u>Surface</u>	

Describe Recorded Data (stream gauge, monitoring well, aerial photos, previous inspections), if available:

Remarks: Saturation observed at the surface in sample plot

WETLAND DETERMINATION DATA FORM – Western Mountains, Valleys, and Coast Region

Project Site: Sound Transit East Link Extension Project City/County: Bellevue/King Sampling Date: Feb. 6, 2013
 Applicant/Owner: Sound Transit State: WA Sampling Point: Mercer Slough JSP6U
 Investigator(s): C Douglas & J. Pursley Section, Township, Range: S5, T24N, R5E
 Landform (hillslope, terrace, etc.): Large wetland system - Mercer Slough Local relief (concave, convex, none): concave Slope (%): 0% to 4%
 Subregion (LRR): A Lat: 47.58N Long: 122.18W Datum: _____
 Soil Map Unit Name: Seattle Muck NWI classification: PFO, PSS, PEM
 Are climatic / hydrologic conditions on the site typical for this time of year? Yes No (If no, explain in Remarks.)
 Are Vegetation , Soil , or Hydrology , significantly disturbed? Are "Normal Circumstances" present? Yes No
 Are Vegetation , Soil , or Hydrology , naturally problematic? (If needed, explain any answers in Remarks.)

SUMMARY OF FINDINGS – Attach site map showing sampling point locations, transects, important features, etc.

Hydrophytic Vegetation Present?	Yes <input checked="" type="checkbox"/>	No <input type="checkbox"/>	Is the Sampled Area within a Wetland?		
Hydric Soil Present?	Yes <input type="checkbox"/>	No <input checked="" type="checkbox"/>		Yes <input type="checkbox"/>	No <input checked="" type="checkbox"/>
Wetland Hydrology Present?	Yes <input type="checkbox"/>	No <input checked="" type="checkbox"/>			
Remarks: Wetland Mercer Slough is a large wetland associated with the Mercer Slough and Lake Washington. Only a portion of the west boundary of wetland delineated as part of this investigation. Area west of wetland boundary includes roads and associated fill prisms. Wetland includes depressionnal, lake-fringe, riverine, and slope HGM classes.					

VEGETATION – Use scientific names of plants

Tree Stratum (Plot size: 30 foot radius)	Absolute % Cover	Dominant Species?	Indicator Status	Dominance Test Worksheet:
1. <u><i>Acer macrophyllum</i></u>	<u>60</u>	<u>yes</u>	<u>FACU</u>	Number of Dominant Species That Are OBL, FACW, or FAC: <u>3</u> (A) Total Number of Dominant Species Across All Strata: <u>5</u> (B) Percent of Dominant Species That Are OBL, FACW, or FAC: <u>60</u> (A/B)
2. <u><i>Pseudotsuga menziesii</i></u>	<u>20</u>	<u>no</u>	<u>FACU</u>	
3. <u><i>Thuja plicata</i></u>	<u>20</u>	<u>yes</u>	<u>FAC</u>	
4. _____	_____	_____	_____	
50% = <u>1</u> , 20% = <u>1</u>	<u>100</u>	= Total Cover		
<u>Sapling/Shrub Stratum (Plot size: 15 foot radius)</u>				Prevalence Index worksheet: Total % Cover of: _____ Multiply by: OBL species _____ x1 = _____ FACW species _____ x2 = _____ FAC species _____ x3 = _____ FACU species _____ x4 = _____ UPL species _____ x5 = _____ Column Totals: _____ (A) _____ (B) Prevalence Index = B/A = _____
1. <u><i>Ilex aquifolium</i></u>	<u>20</u>	<u>no</u>	<u>FACU</u>	
2. <u><i>Oemleria cerasiformis</i></u>	<u>10</u>	<u>no</u>	<u>FACU</u>	
3. <u><i>Rubus spectabilis</i></u>	<u>60</u>	<u>yes</u>	<u>FAC</u>	
4. <u><i>Sambucus racemosa</i></u>	<u>20</u>	<u>yes</u>	<u>FACU</u>	
5. _____	_____	_____	_____	
50% = <u>1</u> , 20% = <u>1</u>	<u>100</u>	= Total Cover		
<u>Herb Stratum (Plot size: 3 foot radius)</u>				Hydrophytic Vegetation Indicators: <input type="checkbox"/> 1 – Rapid Test for Hydrophytic Vegetation <input type="checkbox"/> 2 - Dominance Test is >50% <input type="checkbox"/> 3 - Prevalence Index is ≤3.0 ¹ <input type="checkbox"/> 4 - Morphological Adaptations ¹ (Provide supporting data in Remarks or on a separate sheet) <input type="checkbox"/> 5 - Wetland Non-Vascular Plants ¹ <input type="checkbox"/> Problematic Hydrophytic Vegetation ¹ (Explain) ¹ Indicators of hydric soil and wetland hydrology must be present, unless disturbed or problematic.
1. <u><i>Equisetum telmateia</i></u>	<u>5</u>	<u>yes</u>	<u>FACW</u>	
2. _____	_____	_____	_____	
3. _____	_____	_____	_____	
4. _____	_____	_____	_____	
5. _____	_____	_____	_____	
6. _____	_____	_____	_____	
7. _____	_____	_____	_____	
8. _____	_____	_____	_____	
9. _____	_____	_____	_____	
10. _____	_____	_____	_____	
11. _____	_____	_____	_____	
50% = <u>1</u> , 20% = <u>0</u>	<u>5</u>	= Total Cover		
<u>Woody Vine Stratum (Plot size: 3 foot radius)</u>				
1. _____	_____	_____	_____	
2. _____	_____	_____	_____	
50% = _____, 20% = _____	<u>0</u>	= Total Cover		
% Bare Ground in Herb Stratum <u>95</u>				

Remarks: 60% dominant wetland vegetation per the Dominance Test

SOIL

Profile Description: (Describe to the depth needed to document the indicator or confirm the absence of indicators.)									
Depth (inches)	Matrix		Redox Features				Texture	Remarks	
	Color (moist)	%	Color (moist)	%	Type ¹	Loc ²			
<u>0 to 10</u>	<u>10YR 2/2</u>	<u>100</u>	<u>None</u>	<u>None</u>	<u>None</u>	<u>None</u>	<u>Sandy loam</u>		
<u>10 to 18+</u>	<u>10YR 3/3</u>	<u>100</u>	<u>None</u>	<u>None</u>	<u>None</u>	<u>None</u>	<u>Sandy loam</u>	<u>w/dense roots</u>	
_____	_____	_____	_____	_____	_____	_____	_____	_____	_____
_____	_____	_____	_____	_____	_____	_____	_____	_____	_____
_____	_____	_____	_____	_____	_____	_____	_____	_____	_____
_____	_____	_____	_____	_____	_____	_____	_____	_____	_____
_____	_____	_____	_____	_____	_____	_____	_____	_____	_____

¹Type: C= Concentration, D=Depletion, RM=Reduced Matrix, CS=Covered or Coated Sand Grains. ²Location: PL=Pore Lining, M=Matrix

Hydric Soil Indicators: (Applicable to all LRRs, unless otherwise noted.)				Indicators for Problematic Hydric Soils³:			
<input type="checkbox"/> Histosol (A1)	<input type="checkbox"/> Sandy Redox (S5)	<input type="checkbox"/> 2 cm Muck (A10)					
<input type="checkbox"/> Histic Epipedon (A2)	<input type="checkbox"/> Stripped Matrix (S6)	<input type="checkbox"/> Red Parent Material (TF2)					
<input type="checkbox"/> Black Histic (A3)	<input type="checkbox"/> Loamy Mucky Mineral (F1) (except MLRA 1)	<input type="checkbox"/> Very Shallow Dark Surface (TF12)					
<input type="checkbox"/> Hydrogen Sulfide (A4)	<input type="checkbox"/> Loamy Gleyed Matrix (F2)	<input type="checkbox"/> Other (Explain in Remarks)					
<input type="checkbox"/> Depleted Below Dark Surface (A11)	<input type="checkbox"/> Depleted Matrix (F3)						
<input type="checkbox"/> Thick Dark Surface (A12)	<input type="checkbox"/> Redox Dark Surface (F6)						
<input type="checkbox"/> Sandy Mucky Mineral (S1)	<input type="checkbox"/> Depleted Dark Surface (F7)						
<input type="checkbox"/> Sandy Gleyed Matrix (S4)	<input type="checkbox"/> Redox Depressions (F8)						

³Indicators of hydrophytic vegetation and wetland hydrology must be present, unless disturbed or problematic.

Restrictive Layer (if present): Type: _____ Depth (inches): _____	Hydric Soils Present? Yes <input type="checkbox"/> No <input checked="" type="checkbox"/>
--	--

Remarks: 2 and 3 chroma with no redox features

HYDROLOGY

Wetland Hydrology Indicators:			
Primary Indicators (minimum of one required; check all that apply)		Secondary Indicators (2 or more required)	
<input type="checkbox"/> Surface Water (A1)	<input type="checkbox"/> Water-Stained Leaves (B9)	<input type="checkbox"/> Water-Stained Leaves (B9)	
<input type="checkbox"/> High Water Table (A2)	(except MLRA 1, 2, 4A, and 4B)	(MLRA 1, 2, 4A, and 4B)	
<input type="checkbox"/> Saturation (A3)	<input type="checkbox"/> Salt Crust (B11)	<input type="checkbox"/> Drainage Patterns (B10)	
<input type="checkbox"/> Water Marks (B1)	<input type="checkbox"/> Aquatic Invertebrates (B13)	<input type="checkbox"/> Dry-Season Water Table (C2)	
<input type="checkbox"/> Sediment Deposits (B2)	<input type="checkbox"/> Hydrogen Sulfide Odor (C1)	<input type="checkbox"/> Saturation Visible on Aerial Imagery (C9)	
<input type="checkbox"/> Drift Deposits (B3)	<input type="checkbox"/> Oxidized Rhizospheres along Living Roots (C3)	<input type="checkbox"/> Geomorphic Position (D2)	
<input type="checkbox"/> Algal Mat or Crust (B4)	<input type="checkbox"/> Presence of Reduced Iron (C4)	<input type="checkbox"/> Shallow Aquitard (D3)	
<input type="checkbox"/> Iron Deposits (B5)	<input type="checkbox"/> Recent Iron Reduction in Tilled Soils (C6)	<input type="checkbox"/> FAC-Neutral Test (D5)	
<input type="checkbox"/> Surface Soil Cracks (B6)	<input type="checkbox"/> Stunted or Stresses Plants (D1) (LRR A)	<input type="checkbox"/> Raised Ant Mounds (D6) (LRR A)	
<input type="checkbox"/> Inundation Visible on Aerial Imagery (B7)	<input type="checkbox"/> Other (Explain in Remarks)	<input type="checkbox"/> Frost-Heave Hummocks (D7)	
<input type="checkbox"/> Sparsely Vegetated Concave Surface (B8)			

Field Observations: Surface Water Present? Yes <input type="checkbox"/> No <input checked="" type="checkbox"/> Depth (inches): _____ Water Table Present? Yes <input type="checkbox"/> No <input checked="" type="checkbox"/> Depth (inches): _____ Saturation Present? Yes <input type="checkbox"/> No <input checked="" type="checkbox"/> Depth (inches): _____ (includes capillary fringe)	Wetland Hydrology Present? Yes <input type="checkbox"/> No <input checked="" type="checkbox"/>
---	---

Describe Recorded Data (stream gauge, monitoring well, aerial photos, previous inspections), if available:

Remarks: No saturation or water table observed in sample plot

WETLAND DETERMINATION DATA FORM – Western Mountains, Valleys, and Coast Region

Project Site: Sound Transit East Link Extension Project City/County: Bellevue/King Sampling Date: Feb. 21, 2013
 Applicant/Owner: Sound Transit State: WA Sampling Point: Mercer Slough SP7W
 Investigator(s): C Douglas & J. Pursley Section, Township, Range: S5, T24N, R5E
 Landform (hillslope, terrace, etc.): Large wetland system - Mercer Slough Local relief (concave, convex, none): concave Slope (%): 0% to 4%
 Subregion (LRR): A Lat: 47.58N Long: 122.18W Datum: _____
 Soil Map Unit Name: Seattle Muck NWI classification: PFO, PSS, PEM
 Are climatic / hydrologic conditions on the site typical for this time of year? Yes No (If no, explain in Remarks.)
 Are Vegetation , Soil , or Hydrology , significantly disturbed? Are "Normal Circumstances" present? Yes No
 Are Vegetation , Soil , or Hydrology , naturally problematic? (If needed, explain any answers in Remarks.)

SUMMARY OF FINDINGS – Attach site map showing sampling point locations, transects, important features, etc.

Hydrophytic Vegetation Present?	Yes <input checked="" type="checkbox"/>	No <input type="checkbox"/>	Is the Sampled Area within a Wetland?	Yes <input checked="" type="checkbox"/>	No <input type="checkbox"/>
Hydric Soil Present?	Yes <input checked="" type="checkbox"/>	No <input type="checkbox"/>		Yes <input checked="" type="checkbox"/>	No <input type="checkbox"/>
Wetland Hydrology Present?	Yes <input checked="" type="checkbox"/>	No <input type="checkbox"/>		Yes <input checked="" type="checkbox"/>	No <input type="checkbox"/>
Remarks: Wetland Mercer Slough is a large wetland associated with the Mercer Slough and Lake Washington. Only a portion of the west boundary of wetland delineated as part of this investigation. Area west of wetland boundary includes roads and associated fill prisms. Wetland includes depressional, lake-fringe, riverine, and slope HGM classes.					

VEGETATION – Use scientific names of plants

Tree Stratum (Plot size: 30 foot radius)	Absolute % Cover	Dominant Species?	Indicator Status	Dominance Test Worksheet:																
1. <u><i>Alnus rubra</i></u>	<u>70</u>	<u>yes</u>	<u>FAC</u>	Number of Dominant Species That Are OBL, FACW, or FAC: <u>3</u> (A) Total Number of Dominant Species Across All Strata: <u>3</u> (B) Percent of Dominant Species That Are OBL, FACW, or FAC: <u>100</u> (A/B)																
2. _____	_____	_____	_____																	
3. _____	_____	_____	_____																	
4. _____	_____	_____	_____																	
50% = <u>1</u> , 20% = <u>0</u>	<u>70</u>	= Total Cover		Prevalence Index worksheet: <table style="width: 100%; border: none;"> <tr> <td style="text-align: right;">Total % Cover of:</td> <td style="text-align: right;">Multiply by:</td> </tr> <tr> <td>OBL species _____</td> <td>x1 = _____</td> </tr> <tr> <td>FACW species _____</td> <td>x2 = _____</td> </tr> <tr> <td>FAC species _____</td> <td>x3 = _____</td> </tr> <tr> <td>FACU species _____</td> <td>x4 = _____</td> </tr> <tr> <td>UPL species _____</td> <td>x5 = _____</td> </tr> <tr> <td>Column Totals: _____ (A)</td> <td>_____ (B)</td> </tr> <tr> <td colspan="2" style="text-align: center;">Prevalence Index = B/A = _____</td> </tr> </table>	Total % Cover of:	Multiply by:	OBL species _____	x1 = _____	FACW species _____	x2 = _____	FAC species _____	x3 = _____	FACU species _____	x4 = _____	UPL species _____	x5 = _____	Column Totals: _____ (A)	_____ (B)	Prevalence Index = B/A = _____	
Total % Cover of:	Multiply by:																			
OBL species _____	x1 = _____																			
FACW species _____	x2 = _____																			
FAC species _____	x3 = _____																			
FACU species _____	x4 = _____																			
UPL species _____	x5 = _____																			
Column Totals: _____ (A)	_____ (B)																			
Prevalence Index = B/A = _____																				
Sapling/Shrub Stratum (Plot size: 15 foot radius)																				
1. <u><i>Solanum dulcamara</i></u>	<u>5</u>	<u>yes</u>	<u>FAC</u>	Hydrophytic Vegetation Indicators: <input type="checkbox"/> 1 – Rapid Test for Hydrophytic Vegetation <input checked="" type="checkbox"/> 2 - Dominance Test is >50% <input type="checkbox"/> 3 - Prevalence Index is $\leq 3.0^1$ <input type="checkbox"/> 4 - Morphological Adaptations ¹ (Provide supporting data in Remarks or on a separate sheet) <input type="checkbox"/> 5 - Wetland Non-Vascular Plants ¹ <input type="checkbox"/> Problematic Hydrophytic Vegetation ¹ (Explain) ¹ Indicators of hydric soil and wetland hydrology must be present, unless disturbed or problematic.																
2. _____	_____	_____	_____																	
3. _____	_____	_____	_____																	
4. _____	_____	_____	_____																	
5. _____	_____	_____	_____																	
50% = <u>1</u> , 20% = <u>0</u>	<u>5</u>	= Total Cover																		
Herb Stratum (Plot size: 3 foot radius)																				
1. <u><i>Epilobium watsonii</i></u>	<u>5</u>	<u>no</u>	<u>FACW</u>	Hydrophytic Vegetation Present? Yes <input checked="" type="checkbox"/> No <input type="checkbox"/>																
2. <u><i>Juncus effusus</i></u>	<u>5</u>	<u>no</u>	<u>FACW</u>																	
3. <u><i>Phalaris arundinacea</i></u>	<u>90</u>	<u>yes</u>	<u>FACW</u>																	
4. _____	_____	_____	_____																	
5. _____	_____	_____	_____																	
6. _____	_____	_____	_____																	
7. _____	_____	_____	_____																	
8. _____	_____	_____	_____																	
9. _____	_____	_____	_____																	
10. _____	_____	_____	_____																	
11. _____	_____	_____	_____																	
50% = <u>1</u> , 20% = <u>0</u>	<u>100</u>	= Total Cover																		
Woody Vine Stratum (Plot size: 3 foot radius)																				
1. _____	_____	_____	_____	Hydrophytic Vegetation Present? Yes <input checked="" type="checkbox"/> No <input type="checkbox"/>																
2. _____	_____	_____	_____																	
50% = _____, 20% = _____	<u>0</u>	= Total Cover																		
% Bare Ground in Herb Stratum <u>0</u>																				

Remarks: 100% dominant wetland vegetation per the Dominance Test

SOIL

Profile Description: (Describe to the depth needed to document the indicator or confirm the absence of indicators.)								
Depth (inches)	Matrix		Redox Features				Texture	Remarks
	Color (moist)	%	Color (moist)	%	Type ¹	Loc ²		
0 to 10	<u>10YR 4/1</u>	<u>100</u>	<u>None</u>	<u>None</u>	<u>None</u>	<u>None</u>	<u>Sandy loam</u>	<u>w/cobbles & coarse wood layers</u>
10 to 18+	<u>10YR 5/1</u>	<u>100</u>	<u>None</u>	<u>None</u>	<u>None</u>	<u>None</u>	<u>Sandy loam</u>	<u>w/coarse wood layers</u>
_____	_____	_____	_____	_____	_____	_____	_____	_____
_____	_____	_____	_____	_____	_____	_____	_____	_____
_____	_____	_____	_____	_____	_____	_____	_____	_____
_____	_____	_____	_____	_____	_____	_____	_____	_____
_____	_____	_____	_____	_____	_____	_____	_____	_____
¹ Type: C= Concentration, D=Depletion, RM=Reduced Matrix, CS=Covered or Coated Sand Grains. ² Location: PL=Pore Lining, M=Matrix								
Hydric Soil Indicators: (Applicable to all LRRs, unless otherwise noted.)						Indicators for Problematic Hydric Soils³:		
<input type="checkbox"/> Histosol (A1)			<input type="checkbox"/> Sandy Redox (S5)			<input type="checkbox"/> 2 cm Muck (A10)		
<input type="checkbox"/> Histic Epipedon (A2)			<input type="checkbox"/> Stripped Matrix (S6)			<input type="checkbox"/> Red Parent Material (TF2)		
<input type="checkbox"/> Black Histic (A3)			<input type="checkbox"/> Loamy Mucky Mineral (F1) (except MLRA 1)			<input type="checkbox"/> Very Shallow Dark Surface (TF12)		
<input type="checkbox"/> Hydrogen Sulfide (A4)			<input type="checkbox"/> Loamy Gleyed Matrix (F2)			<input type="checkbox"/> Other (Explain in Remarks)		
<input type="checkbox"/> Depleted Below Dark Surface (A11)			<input type="checkbox"/> Depleted Matrix (F3)			³ Indicators of hydrophytic vegetation and wetland hydrology must be present, unless disturbed or problematic.		
<input checked="" type="checkbox"/> Thick Dark Surface (A12)			<input type="checkbox"/> Redox Dark Surface (F6)					
<input type="checkbox"/> Sandy Mucky Mineral (S1)			<input type="checkbox"/> Depleted Dark Surface (F7)					
<input type="checkbox"/> Sandy Gleyed Matrix (S4)			<input type="checkbox"/> Redox Depressions (F8)					
Restrictive Layer (if present):					Hydric Soils Present?			
Type: _____					Yes <input checked="" type="checkbox"/> No <input type="checkbox"/>			
Depth (inches): _____								
Remarks: 1 chroma								

HYDROLOGY

Wetland Hydrology Indicators:			
Primary Indicators (minimum of one required; check all that apply)		Secondary Indicators (2 or more required)	
<input type="checkbox"/> Surface Water (A1)	<input checked="" type="checkbox"/> Water-Stained Leaves (B9)	<input type="checkbox"/> Water-Stained Leaves (B9)	
<input checked="" type="checkbox"/> High Water Table (A2)	(except MLRA 1, 2, 4A, and 4B)	(MLRA 1, 2, 4A, and 4B)	
<input checked="" type="checkbox"/> Saturation (A3)	<input type="checkbox"/> Salt Crust (B11)	<input type="checkbox"/> Drainage Patterns (B10)	
<input type="checkbox"/> Water Marks (B1)	<input type="checkbox"/> Aquatic Invertebrates (B13)	<input type="checkbox"/> Dry-Season Water Table (C2)	
<input type="checkbox"/> Sediment Deposits (B2)	<input type="checkbox"/> Hydrogen Sulfide Odor (C1)	<input type="checkbox"/> Saturation Visible on Aerial Imagery (C9)	
<input type="checkbox"/> Drift Deposits (B3)	<input type="checkbox"/> Oxidized Rhizospheres along Living Roots (C3)	<input type="checkbox"/> Geomorphic Position (D2)	
<input type="checkbox"/> Algal Mat or Crust (B4)	<input type="checkbox"/> Presence of Reduced Iron (C4)	<input type="checkbox"/> Shallow Aquitard (D3)	
<input type="checkbox"/> Iron Deposits (B5)	<input type="checkbox"/> Recent Iron Reduction in Tilled Soils (C6)	<input type="checkbox"/> FAC-Neutral Test (D5)	
<input type="checkbox"/> Surface Soil Cracks (B6)	<input type="checkbox"/> Stunted or Stresses Plants (D1) (LRR A)	<input type="checkbox"/> Raised Ant Mounds (D6) (LRR A)	
<input type="checkbox"/> Inundation Visible on Aerial Imagery (B7)	<input type="checkbox"/> Other (Explain in Remarks)	<input type="checkbox"/> Frost-Heave Hummocks (D7)	
<input type="checkbox"/> Sparsely Vegetated Concave Surface (B8)			
Field Observations:		Wetland Hydrology Present?	
Surface Water Present?	Yes <input type="checkbox"/> No <input checked="" type="checkbox"/>	Depth (inches):	_____
Water Table Present?	Yes <input checked="" type="checkbox"/> No <input type="checkbox"/>	Depth (inches):	<u>7 inches</u>
Saturation Present? (includes capillary fringe)	Yes <input checked="" type="checkbox"/> No <input type="checkbox"/>	Depth (inches):	<u>Surface</u>
Describe Recorded Data (stream gauge, monitoring well, aerial photos, previous inspections), if available:		Yes <input checked="" type="checkbox"/> No <input type="checkbox"/>	
Remarks: Saturation and water table observed in sample plot			

WETLAND DETERMINATION DATA FORM – Western Mountains, Valleys, and Coast Region

Project Site: Sound Transit East Link Extension Project City/County: Bellevue/King Sampling Date: Feb. 21, 2013
 Applicant/Owner: Sound Transit State: WA Sampling Point: Mercer Slough SP8U
 Investigator(s): C Douglas & J. Pursley Section, Township, Range: S5, T24N, R5E
 Landform (hillslope, terrace, etc.): Large wetland system - Mercer Slough Local relief (concave, convex, none): concave Slope (%): 0% to 4%
 Subregion (LRR): A Lat: 47.58N Long: 122.18W Datum: _____
 Soil Map Unit Name: Seattle Muck NWI classification: PFO, PSS, PEM
 Are climatic / hydrologic conditions on the site typical for this time of year? Yes No (If no, explain in Remarks.)
 Are Vegetation , Soil , or Hydrology , significantly disturbed? Are "Normal Circumstances" present? Yes No
 Are Vegetation , Soil , or Hydrology , naturally problematic? (If needed, explain any answers in Remarks.)

SUMMARY OF FINDINGS – Attach site map showing sampling point locations, transects, important features, etc.

Hydrophytic Vegetation Present?	Yes <input checked="" type="checkbox"/>	No <input type="checkbox"/>	Is the Sampled Area within a Wetland?		
Hydric Soil Present?	Yes <input type="checkbox"/>	No <input checked="" type="checkbox"/>		Yes <input type="checkbox"/>	No <input checked="" type="checkbox"/>
Wetland Hydrology Present?	Yes <input type="checkbox"/>	No <input checked="" type="checkbox"/>			
Remarks: Wetland Mercer Slough is a large wetland associated with the Mercer Slough and Lake Washington. Only a portion of the west boundary of wetland delineated as part of this investigation. Area west of wetland boundary includes roads and associated fill prisms. Wetland includes depressional, lake-fringe, riverine, and slope HGM classes.					

VEGETATION – Use scientific names of plants

Tree Stratum (Plot size: 30 foot radius)	Absolute % Cover	Dominant Species?	Indicator Status	Dominance Test Worksheet:																
1. <u><i>Alnus rubra</i></u>	<u>60</u>	<u>yes</u>	<u>FAC</u>	Number of Dominant Species That Are OBL, FACW, or FAC: <u>4</u> (A) Total Number of Dominant Species Across All Strata: <u>5</u> (B) Percent of Dominant Species That Are OBL, FACW, or FAC: <u>80</u> (A/B)																
2. _____	_____	_____	_____																	
3. _____	_____	_____	_____																	
4. _____	_____	_____	_____																	
50% = <u>1</u> , 20% = <u>0</u>	<u>60</u>	= Total Cover																		
<u>Sapling/Shrub Stratum (Plot size: 15 foot radius)</u>				Prevalence Index worksheet: <table style="width: 100%; border: none;"> <tr> <td style="width: 50%; text-align: center;"><u>Total % Cover of:</u></td> <td style="width: 50%; text-align: center;"><u>Multiply by:</u></td> </tr> <tr> <td>OBL species _____</td> <td>x1 = _____</td> </tr> <tr> <td>FACW species _____</td> <td>x2 = _____</td> </tr> <tr> <td>FAC species _____</td> <td>x3 = _____</td> </tr> <tr> <td>FACU species _____</td> <td>x4 = _____</td> </tr> <tr> <td>UPL species _____</td> <td>x5 = _____</td> </tr> <tr> <td>Column Totals: _____ (A)</td> <td>_____ (B)</td> </tr> <tr> <td colspan="2" style="text-align: center;">Prevalence Index = B/A = _____</td> </tr> </table>	<u>Total % Cover of:</u>	<u>Multiply by:</u>	OBL species _____	x1 = _____	FACW species _____	x2 = _____	FAC species _____	x3 = _____	FACU species _____	x4 = _____	UPL species _____	x5 = _____	Column Totals: _____ (A)	_____ (B)	Prevalence Index = B/A = _____	
<u>Total % Cover of:</u>	<u>Multiply by:</u>																			
OBL species _____	x1 = _____																			
FACW species _____	x2 = _____																			
FAC species _____	x3 = _____																			
FACU species _____	x4 = _____																			
UPL species _____	x5 = _____																			
Column Totals: _____ (A)	_____ (B)																			
Prevalence Index = B/A = _____																				
1. <u><i>Acer circinatum</i></u>	<u>30</u>	<u>yes</u>	<u>FAC</u>																	
2. <u><i>Ilex aquifolium</i></u>	<u>10</u>	<u>no</u>	<u>FACU</u>																	
3. <u><i>Rubus armeniacus</i></u>	<u>30</u>	<u>yes</u>	<u>FACU</u>																	
4. <u><i>Rubus spectabilis</i></u>	<u>40</u>	<u>yes</u>	<u>FAC</u>																	
5. _____	_____	_____	_____																	
50% = <u>0</u> , 20% = <u>3</u>	<u>100</u>	= Total Cover																		
<u>Herb Stratum (Plot size: 3 foot radius)</u>																				
1. <u><i>Phalaris arundinacea</i></u>	<u>5</u>	<u>yes</u>	<u>FACW</u>																	
2. _____	_____	_____	_____																	
3. _____	_____	_____	_____																	
4. _____	_____	_____	_____																	
5. _____	_____	_____	_____																	
6. _____	_____	_____	_____																	
7. _____	_____	_____	_____																	
8. _____	_____	_____	_____																	
9. _____	_____	_____	_____																	
10. _____	_____	_____	_____																	
11. _____	_____	_____	_____																	
50% = <u>1</u> , 20% = <u>0</u>	<u>5</u>	= Total Cover																		
<u>Woody Vine Stratum (Plot size: 3 foot radius)</u>																				
1. _____	_____	_____	_____																	
2. _____	_____	_____	_____																	
50% = _____, 20% = _____	<u>0</u>	= Total Cover																		
% Bare Ground in Herb Stratum <u>95</u>																				

Hydrophytic Vegetation Indicators:

1 – Rapid Test for Hydrophytic Vegetation

2 - Dominance Test is >50%

3 - Prevalence Index is $\leq 3.0^1$

4 - Morphological Adaptations¹ (Provide supporting data in Remarks or on a separate sheet)

5 - Wetland Non-Vascular Plants¹

Problematic Hydrophytic Vegetation¹ (Explain)

¹Indicators of hydric soil and wetland hydrology must be present, unless disturbed or problematic.

Hydrophytic Vegetation Present? Yes No

Remarks: 80% dominant wetland vegetation per the Dominance Test

SOIL

Profile Description: (Describe to the depth needed to document the indicator or confirm the absence of indicators.)								
Depth (inches)	Matrix		Redox Features				Texture	Remarks
	Color (moist)	%	Color (moist)	%	Type ¹	Loc ²		
0 to 18+	10YR 3/3	100	None	None	None	None	Sandy loam	w/gravel & cobble
¹ Type: C= Concentration, D=Depletion, RM=Reduced Matrix, CS=Covered or Coated Sand Grains. ² Location: PL=Pore Lining, M=Matrix								
Hydric Soil Indicators: (Applicable to all LRRs, unless otherwise noted.)						Indicators for Problematic Hydric Soils³:		
<input type="checkbox"/> Histosol (A1)						<input type="checkbox"/> 2 cm Muck (A10)		
<input type="checkbox"/> Histic Epipedon (A2)						<input type="checkbox"/> Red Parent Material (TF2)		
<input type="checkbox"/> Black Histic (A3)						<input type="checkbox"/> Very Shallow Dark Surface (TF12)		
<input type="checkbox"/> Hydrogen Sulfide (A4)						<input type="checkbox"/> Other (Explain in Remarks)		
<input type="checkbox"/> Depleted Below Dark Surface (A11)						³ Indicators of hydrophytic vegetation and wetland hydrology must be present, unless disturbed or problematic.		
<input type="checkbox"/> Thick Dark Surface (A12)								
<input type="checkbox"/> Sandy Mucky Mineral (S1)								
<input type="checkbox"/> Sandy Gleyed Matrix (S4)								
<input type="checkbox"/> Sandy Redox (S5)								
<input type="checkbox"/> Stripped Matrix (S6)								
<input type="checkbox"/> Loamy Mucky Mineral (F1) (except MLRA 1)								
<input type="checkbox"/> Loamy Gleyed Matrix (F2)								
<input type="checkbox"/> Depleted Matrix (F3)								
<input type="checkbox"/> Redox Dark Surface (F6)								
<input type="checkbox"/> Depleted Dark Surface (F7)								
<input type="checkbox"/> Redox Depressions (F8)								
Restrictive Layer (if present):								
Type: _____								
Depth (inches): _____								
Remarks: 2 and 3 chroma with no redox features					Hydric Soils Present? Yes <input type="checkbox"/> No <input checked="" type="checkbox"/>			

HYDROLOGY

Wetland Hydrology Indicators:			
Primary Indicators (minimum of one required; check all that apply)		Secondary Indicators (2 or more required)	
<input type="checkbox"/> Surface Water (A1)	<input type="checkbox"/> Water-Stained Leaves (B9)	<input type="checkbox"/> Water-Stained Leaves (B9)	
<input type="checkbox"/> High Water Table (A2)	(except MLRA 1, 2, 4A, and 4B)	(MLRA 1, 2, 4A, and 4B)	
<input type="checkbox"/> Saturation (A3)	<input type="checkbox"/> Salt Crust (B11)	<input type="checkbox"/> Drainage Patterns (B10)	
<input type="checkbox"/> Water Marks (B1)	<input type="checkbox"/> Aquatic Invertebrates (B13)	<input type="checkbox"/> Dry-Season Water Table (C2)	
<input type="checkbox"/> Sediment Deposits (B2)	<input type="checkbox"/> Hydrogen Sulfide Odor (C1)	<input type="checkbox"/> Saturation Visible on Aerial Imagery (C9)	
<input type="checkbox"/> Drift Deposits (B3)	<input type="checkbox"/> Oxidized Rhizospheres along Living Roots (C3)	<input type="checkbox"/> Geomorphic Position (D2)	
<input type="checkbox"/> Algal Mat or Crust (B4)	<input type="checkbox"/> Presence of Reduced Iron (C4)	<input type="checkbox"/> Shallow Aquitard (D3)	
<input type="checkbox"/> Iron Deposits (B5)	<input type="checkbox"/> Recent Iron Reduction in Tilled Soils (C6)	<input type="checkbox"/> FAC-Neutral Test (D5)	
<input type="checkbox"/> Surface Soil Cracks (B6)	<input type="checkbox"/> Stunted or Stresses Plants (D1) (LRR A)	<input type="checkbox"/> Raised Ant Mounds (D6) (LRR A)	
<input type="checkbox"/> Inundation Visible on Aerial Imagery (B7)	<input type="checkbox"/> Other (Explain in Remarks)	<input type="checkbox"/> Frost-Heave Hummocks (D7)	
<input type="checkbox"/> Sparsely Vegetated Concave Surface (B8)			
Field Observations:			
Surface Water Present?	Yes <input type="checkbox"/> No <input checked="" type="checkbox"/>	Depth (inches):	_____
Water Table Present?	Yes <input type="checkbox"/> No <input checked="" type="checkbox"/>	Depth (inches):	_____
Saturation Present? (includes capillary fringe)	Yes <input type="checkbox"/> No <input checked="" type="checkbox"/>	Depth (inches):	_____
		Wetland Hydrology Present? Yes <input type="checkbox"/> No <input checked="" type="checkbox"/>	
Describe Recorded Data (stream gauge, monitoring well, aerial photos, previous inspections), if available:			
Remarks: No saturation or water table observed in sample plot			

WETLAND DETERMINATION DATA FORM – Western Mountains, Valleys, and Coast Region

Project Site: Sound Transit East Link Extension Project City/County: Bellevue/King Sampling Date: Feb. 21, 2013
 Applicant/Owner: Sound Transit State: WA Sampling Point: Mercer Slough SP9W
 Investigator(s): C Douglas & J. Pursley Section, Township, Range: S5, T24N, R5E
 Landform (hillslope, terrace, etc.): Large wetland system - Mercer Slough Local relief (concave, convex, none): concave Slope (%): 0% to 4%
 Subregion (LRR): A Lat: 47.58N Long: 122.18W Datum: _____
 Soil Map Unit Name: Seattle Muck NWI classification: PFO, PSS, PEM
 Are climatic / hydrologic conditions on the site typical for this time of year? Yes No (If no, explain in Remarks.)
 Are Vegetation , Soil , or Hydrology , significantly disturbed? Are "Normal Circumstances" present? Yes No
 Are Vegetation , Soil , or Hydrology , naturally problematic? (If needed, explain any answers in Remarks.)

SUMMARY OF FINDINGS – Attach site map showing sampling point locations, transects, important features, etc.

Hydrophytic Vegetation Present?	Yes <input checked="" type="checkbox"/>	No <input type="checkbox"/>	Is the Sampled Area within a Wetland?	Yes <input checked="" type="checkbox"/>	No <input type="checkbox"/>
Hydric Soil Present?	Yes <input checked="" type="checkbox"/>	No <input type="checkbox"/>		Yes <input checked="" type="checkbox"/>	No <input type="checkbox"/>
Wetland Hydrology Present?	Yes <input checked="" type="checkbox"/>	No <input type="checkbox"/>			
Remarks: Wetland Mercer Slough is a large wetland associated with the Mercer Slough and Lake Washington. Only a portion of the west boundary of wetland delineated as part of this investigation. Area west of wetland boundary includes roads and associated fill prisms. Wetland includes depressional, lake-fringe, riverine, and slope HGM classes.					

VEGETATION – Use scientific names of plants

Tree Stratum (Plot size: 30 foot radius)	Absolute % Cover	Dominant Species?	Indicator Status	Dominance Test Worksheet:																	
1. <u>Salix lasiandra</u>	<u>90</u>	<u>yes</u>	<u>FACW</u>	Number of Dominant Species That Are OBL, FACW, or FAC:	<u>3</u> (A)																
2. _____	_____	_____	_____	Total Number of Dominant Species Across All Strata:	<u>3</u> (B)																
3. _____	_____	_____	_____	Percent of Dominant Species That Are OBL, FACW, or FAC:	<u>100</u> (A/B)																
4. _____	_____	_____	_____																		
50% = <u>1</u> , 20% = <u>0</u>	<u>90</u>	= Total Cover																			
<u>Sapling/Shrub Stratum (Plot size: 15 foot radius)</u>																					
1. <u>Cornus sericea</u>	<u>30</u>	<u>yes</u>	<u>FACW</u>	Prevalence Index worksheet: <table style="width: 100%; border: none;"> <tr> <td style="text-align: right;">Total % Cover of:</td> <td style="text-align: left;">Multiply by:</td> </tr> <tr> <td>OBL species _____</td> <td>x1 = _____</td> </tr> <tr> <td>FACW species _____</td> <td>x2 = _____</td> </tr> <tr> <td>FAC species _____</td> <td>x3 = _____</td> </tr> <tr> <td>FACU species _____</td> <td>x4 = _____</td> </tr> <tr> <td>UPL species _____</td> <td>x5 = _____</td> </tr> <tr> <td>Column Totals: _____ (A)</td> <td>_____ (B)</td> </tr> <tr> <td colspan="2" style="text-align: center;">Prevalence Index = B/A = _____</td> </tr> </table>		Total % Cover of:	Multiply by:	OBL species _____	x1 = _____	FACW species _____	x2 = _____	FAC species _____	x3 = _____	FACU species _____	x4 = _____	UPL species _____	x5 = _____	Column Totals: _____ (A)	_____ (B)	Prevalence Index = B/A = _____	
Total % Cover of:	Multiply by:																				
OBL species _____	x1 = _____																				
FACW species _____	x2 = _____																				
FAC species _____	x3 = _____																				
FACU species _____	x4 = _____																				
UPL species _____	x5 = _____																				
Column Totals: _____ (A)	_____ (B)																				
Prevalence Index = B/A = _____																					
2. <u>Rubus armeniacus</u>	<u>5</u>	<u>no</u>	<u>FACU</u>																		
3. _____	_____	_____	_____																		
4. _____	_____	_____	_____																		
5. _____	_____	_____	_____																		
50% = <u>1</u> , 20% = <u>0</u>	<u>35</u>	= Total Cover																			
<u>Herb Stratum (Plot size: 3 foot radius)</u>																					
1. <u>Ranunculus repens</u>	<u>50</u>	<u>yes</u>	<u>FACW</u>	Hydrophytic Vegetation Indicators: <input type="checkbox"/> 1 – Rapid Test for Hydrophytic Vegetation <input checked="" type="checkbox"/> 2 - Dominance Test is >50% <input type="checkbox"/> 3 - Prevalence Index is $\leq 3.0^1$ <input type="checkbox"/> 4 - Morphological Adaptations ¹ (Provide supporting data in Remarks or on a separate sheet) <input type="checkbox"/> 5 - Wetland Non-Vascular Plants ¹ <input type="checkbox"/> Problematic Hydrophytic Vegetation ¹ (Explain) ¹ Indicators of hydric soil and wetland hydrology must be present, unless disturbed or problematic.																	
2. _____	_____	_____	_____																		
3. _____	_____	_____	_____																		
4. _____	_____	_____	_____																		
5. _____	_____	_____	_____																		
6. _____	_____	_____	_____																		
7. _____	_____	_____	_____																		
8. _____	_____	_____	_____																		
9. _____	_____	_____	_____																		
10. _____	_____	_____	_____																		
11. _____	_____	_____	_____																		
50% = <u>1</u> , 20% = <u>0</u>	<u>50</u>	= Total Cover																			
<u>Woody Vine Stratum (Plot size: 3 foot radius)</u>																					
1. _____	_____	_____	_____	Hydrophytic Vegetation Present? <table style="width: 100%; border: none;"> <tr> <td style="text-align: right;">Yes</td> <td style="text-align: center;"><input checked="" type="checkbox"/></td> <td style="text-align: right;">No</td> <td style="text-align: center;"><input type="checkbox"/></td> </tr> </table>		Yes	<input checked="" type="checkbox"/>	No	<input type="checkbox"/>												
Yes	<input checked="" type="checkbox"/>	No	<input type="checkbox"/>																		
2. _____	_____	_____	_____																		
50% = _____, 20% = _____	<u>0</u>	= Total Cover																			
% Bare Ground in Herb Stratum <u>50</u>																					

Remarks: 100% dominant wetland vegetation per the Dominance Test

SOIL

Profile Description: (Describe to the depth needed to document the indicator or confirm the absence of indicators.)								
Depth (inches)	Matrix		Redox Features				Texture	Remarks
	Color (moist)	%	Color (moist)	%	Type ¹	Loc ²		
0 to 6	<u>10YR 3/1</u>	<u>100</u>	<u>None</u>	<u>None</u>	<u>None</u>	<u>None</u>	<u>Loam</u>	<u>w/gravel</u>
6 to 18+	<u>10YR 4/1</u>	<u>95</u>	<u>10YR 6/2</u>	<u>5</u>	<u>D</u>	<u>M</u>	<u>Clay loam</u>	<u>w/cobble & gravel</u>
¹ Type: C= Concentration, D=Depletion, RM=Reduced Matrix, CS=Covered or Coated Sand Grains. ² Location: PL=Pore Lining, M=Matrix								
Hydric Soil Indicators: (Applicable to all LRRs, unless otherwise noted.)						Indicators for Problematic Hydric Soils³:		
<input type="checkbox"/> Histosol (A1)			<input type="checkbox"/> Sandy Redox (S5)			<input type="checkbox"/> 2 cm Muck (A10)		
<input type="checkbox"/> Histic Epipedon (A2)			<input type="checkbox"/> Stripped Matrix (S6)			<input type="checkbox"/> Red Parent Material (TF2)		
<input type="checkbox"/> Black Histic (A3)			<input type="checkbox"/> Loamy Mucky Mineral (F1) (except MLRA 1)			<input type="checkbox"/> Very Shallow Dark Surface (TF12)		
<input type="checkbox"/> Hydrogen Sulfide (A4)			<input type="checkbox"/> Loamy Gleyed Matrix (F2)			<input type="checkbox"/> Other (Explain in Remarks)		
<input type="checkbox"/> Depleted Below Dark Surface (A11)			<input checked="" type="checkbox"/> Depleted Matrix (F3)			³ Indicators of hydrophytic vegetation and wetland hydrology must be present, unless disturbed or problematic.		
<input checked="" type="checkbox"/> Thick Dark Surface (A12)			<input type="checkbox"/> Redox Dark Surface (F6)					
<input type="checkbox"/> Sandy Mucky Mineral (S1)			<input type="checkbox"/> Depleted Dark Surface (F7)					
<input type="checkbox"/> Sandy Gleyed Matrix (S4)			<input type="checkbox"/> Redox Depressions (F8)					
Restrictive Layer (if present):					Hydric Soils Present?			
Type: _____					Yes <input checked="" type="checkbox"/> No <input type="checkbox"/>			
Depth (inches): _____								
Remarks: 1 chroma with redox features								

HYDROLOGY

Wetland Hydrology Indicators:			
Primary Indicators (minimum of one required; check all that apply)		Secondary Indicators (2 or more required)	
<input type="checkbox"/> Surface Water (A1)	<input type="checkbox"/> Water-Stained Leaves (B9)	<input type="checkbox"/> Water-Stained Leaves (B9)	
<input type="checkbox"/> High Water Table (A2)	(except MLRA 1, 2, 4A, and 4B)	(MLRA 1, 2, 4A, and 4B)	
<input checked="" type="checkbox"/> Saturation (A3)	<input type="checkbox"/> Salt Crust (B11)	<input type="checkbox"/> Drainage Patterns (B10)	
<input type="checkbox"/> Water Marks (B1)	<input type="checkbox"/> Aquatic Invertebrates (B13)	<input type="checkbox"/> Dry-Season Water Table (C2)	
<input type="checkbox"/> Sediment Deposits (B2)	<input type="checkbox"/> Hydrogen Sulfide Odor (C1)	<input type="checkbox"/> Saturation Visible on Aerial Imagery (C9)	
<input type="checkbox"/> Drift Deposits (B3)	<input type="checkbox"/> Oxidized Rhizospheres along Living Roots (C3)	<input type="checkbox"/> Geomorphic Position (D2)	
<input type="checkbox"/> Algal Mat or Crust (B4)	<input type="checkbox"/> Presence of Reduced Iron (C4)	<input type="checkbox"/> Shallow Aquitard (D3)	
<input type="checkbox"/> Iron Deposits (B5)	<input type="checkbox"/> Recent Iron Reduction in Tilled Soils (C6)	<input type="checkbox"/> FAC-Neutral Test (D5)	
<input type="checkbox"/> Surface Soil Cracks (B6)	<input type="checkbox"/> Stunted or Stresses Plants (D1) (LRR A)	<input type="checkbox"/> Raised Ant Mounds (D6) (LRR A)	
<input type="checkbox"/> Inundation Visible on Aerial Imagery (B7)	<input type="checkbox"/> Other (Explain in Remarks)	<input type="checkbox"/> Frost-Heave Hummocks (D7)	
<input type="checkbox"/> Sparsely Vegetated Concave Surface (B8)			
Field Observations:		Wetland Hydrology Present?	
Surface Water Present?	Yes <input type="checkbox"/> No <input checked="" type="checkbox"/>	Yes <input checked="" type="checkbox"/> No <input type="checkbox"/>	Depth (inches): _____
Water Table Present?	Yes <input type="checkbox"/> No <input checked="" type="checkbox"/>		Depth (inches): _____
Saturation Present? (includes capillary fringe)	Yes <input checked="" type="checkbox"/> No <input type="checkbox"/>		Depth (inches): <u>Surface</u>
Describe Recorded Data (stream gauge, monitoring well, aerial photos, previous inspections), if available:			
Remarks: Saturation at surface with no water table observed in sample plot			

WETLAND DETERMINATION DATA FORM – Western Mountains, Valleys, and Coast Region

Project Site: Sound Transit East Link Extension Project City/County: Bellevue/King Sampling Date: Feb. 14, 2013
 Applicant/Owner: Sound Transit State: WA Sampling Point: North Lake SPU
 Investigator(s): C Douglas & J. Pursley Section, Township, Range: S29, T24N, R5E
 Landform (hillslope, terrace, etc.): Narrow area between development Local relief (concave, convex, none): concave Slope (%): 0% to 2%
 Subregion (LRR): A Lat: 47.62N Long: 122.18W Datum: _____
 Soil Map Unit Name: Alderwood gravelly sandy loam NWI classification: None Mapped
 Are climatic / hydrologic conditions on the site typical for this time of year? Yes No (If no, explain in Remarks.)
 Are Vegetation , Soil , or Hydrology , significantly disturbed? Are "Normal Circumstances" present? Yes No
 Are Vegetation , Soil , or Hydrology , naturally problematic? (If needed, explain any answers in Remarks.)

SUMMARY OF FINDINGS – Attach site map showing sampling point locations, transects, important features, etc.

Hydrophytic Vegetation Present?	Yes <input checked="" type="checkbox"/>	No <input type="checkbox"/>	Is the Sampled Area within a Wetland?	Yes <input type="checkbox"/>	No <input checked="" type="checkbox"/>
Hydric Soil Present?	Yes <input type="checkbox"/>	No <input checked="" type="checkbox"/>		Yes <input type="checkbox"/>	No <input checked="" type="checkbox"/>
Wetland Hydrology Present?	Yes <input type="checkbox"/>	No <input checked="" type="checkbox"/>		Yes <input type="checkbox"/>	No <input checked="" type="checkbox"/>
Remarks: Wetland North Lake is located in narrow area between railroad tracks and commercial development. Wetland includes slope HGM class.					

VEGETATION – Use scientific names of plants

Tree Stratum (Plot size: 30 foot radius)	Absolute % Cover	Dominant Species?	Indicator Status	Dominance Test Worksheet:																
1. _____	_____	_____	_____	Number of Dominant Species That Are OBL, FACW, or FAC: 1 (A) Total Number of Dominant Species Across All Strata: 2 (B) Percent of Dominant Species That Are OBL, FACW, or FAC: 50 (A/B)																
2. _____	_____	_____	_____																	
3. _____	_____	_____	_____																	
4. _____	_____	_____	_____																	
50% = 0, 20% = 0	0	= Total Cover		Prevalence Index worksheet: <table style="width: 100%; border: none;"> <tr> <td style="text-align: center;">Total % Cover of:</td> <td style="text-align: center;">Multiply by:</td> </tr> <tr> <td>OBL species _____</td> <td>x1 = _____</td> </tr> <tr> <td>FACW species _____</td> <td>x2 = _____</td> </tr> <tr> <td>FAC species _____</td> <td>x3 = _____</td> </tr> <tr> <td>FACU species _____</td> <td>x4 = _____</td> </tr> <tr> <td>UPL species _____</td> <td>x5 = _____</td> </tr> <tr> <td>Column Totals: _____ (A)</td> <td>_____ (B)</td> </tr> <tr> <td colspan="2" style="text-align: center;">Prevalence Index = B/A = _____</td> </tr> </table>	Total % Cover of:	Multiply by:	OBL species _____	x1 = _____	FACW species _____	x2 = _____	FAC species _____	x3 = _____	FACU species _____	x4 = _____	UPL species _____	x5 = _____	Column Totals: _____ (A)	_____ (B)	Prevalence Index = B/A = _____	
Total % Cover of:	Multiply by:																			
OBL species _____	x1 = _____																			
FACW species _____	x2 = _____																			
FAC species _____	x3 = _____																			
FACU species _____	x4 = _____																			
UPL species _____	x5 = _____																			
Column Totals: _____ (A)	_____ (B)																			
Prevalence Index = B/A = _____																				
Sapling/Shrub Stratum (Plot size: 15 foot radius)																				
1. <u>Rubus armeniacus</u>	20	yes	FACU																	
2. _____	_____	_____	_____																	
3. _____	_____	_____	_____																	
4. _____	_____	_____	_____																	
5. _____	_____	_____	_____																	
50% = 1, 20% = 0	20	= Total Cover																		
Herb Stratum (Plot size: 3 foot radius)																				
1. <u>Cirsium arvense</u>	5	no	FACU																	
2. <u>Epilobium watsonii</u>	1	no	FACW																	
3. <u>Equisetum arvense</u>	1	no	FAC																	
4. <u>Juncus effusus</u>	20	no	FACW																	
5. <u>Phalaris arundinacea</u>	80	yes	FACW																	
6. _____	_____	_____	_____																	
7. _____	_____	_____	_____																	
8. _____	_____	_____	_____																	
9. _____	_____	_____	_____																	
10. _____	_____	_____	_____																	
11. _____	_____	_____	_____																	
50% = 1, 20% = 0	100	= Total Cover																		
Woody Vine Stratum (Plot size: 3 foot radius)																				
1. _____	_____	_____	_____																	
2. _____	_____	_____	_____																	
50% = _____, 20% = _____	0	= Total Cover																		
% Bare Ground in Herb Stratum 0																				
Hydrophytic Vegetation Present? Yes <input checked="" type="checkbox"/> No <input type="checkbox"/>																				

Remarks: 50% dominant wetland vegetation per the Dominance Test, only 2 dominant species.

SOIL

Profile Description: (Describe to the depth needed to document the indicator or confirm the absence of indicators.)

Depth (inches)	Matrix		Redox Features				Texture	Remarks
	Color (moist)	%	Color (moist)	%	Type ¹	Loc ²		
0 to 18+	10YR 3/3	100	None	None	None	None	Sandy loam	w/cobble
_____	_____	_____	_____	_____	_____	_____	_____	_____
_____	_____	_____	_____	_____	_____	_____	_____	_____
_____	_____	_____	_____	_____	_____	_____	_____	_____
_____	_____	_____	_____	_____	_____	_____	_____	_____
_____	_____	_____	_____	_____	_____	_____	_____	_____

¹Type: C= Concentration, D=Depletion, RM=Reduced Matrix, CS=Covered or Coated Sand Grains. ²Location: PL=Pore Lining, M=Matrix

Hydric Soil Indicators: (Applicable to all LRRs, unless otherwise noted.)

- Histosol (A1)
- Histic Epipedon (A2)
- Black Histic (A3)
- Hydrogen Sulfide (A4)
- Depleted Below Dark Surface (A11)
- Thick Dark Surface (A12)
- Sandy Mucky Mineral (S1)
- Sandy Gleyed Matrix (S4)

- Sandy Redox (S5)
- Stripped Matrix (S6)
- Loamy Mucky Mineral (F1) **(except MLRA 1)**
- Loamy Gleyed Matrix (F2)
- Depleted Matrix (F3)
- Redox Dark Surface (F6)
- Depleted Dark Surface (F7)
- Redox Depressions (F8)

Indicators for Problematic Hydric Soils³:

- 2 cm Muck (A10)
- Red Parent Material (TF2)
- Very Shallow Dark Surface (TF12)
- Other (Explain in Remarks)

³Indicators of hydrophytic vegetation and wetland hydrology must be present, unless disturbed or problematic.

Restrictive Layer (if present):

Type: _____
 Depth (inches): _____

Hydric Soils Present? Yes No

Remarks: 3 chroma

HYDROLOGY

Wetland Hydrology Indicators:

Primary Indicators (minimum of one required; check all that apply)

- Surface Water (A1)
- High Water Table (A2)
- Saturation (A3)
- Water Marks (B1)
- Sediment Deposits (B2)
- Drift Deposits (B3)
- Algal Mat or Crust (B4)
- Iron Deposits (B5)
- Surface Soil Cracks (B6)
- Inundation Visible on Aerial Imagery (B7)
- Sparsely Vegetated Concave Surface (B8)
- Water-Stained Leaves (B9) **(except MLRA 1, 2, 4A, and 4B)**
- Salt Crust (B11)
- Aquatic Invertebrates (B13)
- Hydrogen Sulfide Odor (C1)
- Oxidized Rhizospheres along Living Roots (C3)
- Presence of Reduced Iron (C4)
- Recent Iron Reduction in Tilled Soils (C6)
- Stunted or Stresses Plants (D1) **(LRR A)**
- Other (Explain in Remarks)

Secondary Indicators (2 or more required)

- Water-Stained Leaves (B9) **(MLRA 1, 2, 4A, and 4B)**
- Drainage Patterns (B10)
- Dry-Season Water Table (C2)
- Saturation Visible on Aerial Imagery (C9)
- Geomorphic Position (D2)
- Shallow Aquitard (D3)
- FAC-Neutral Test (D5)
- Raised Ant Mounds (D6) **(LRR A)**
- Frost-Heave Hummocks (D7)

Field Observations:

Surface Water Present? Yes No Depth (inches): _____
 Water Table Present? Yes No Depth (inches): _____
 Saturation Present? (includes capillary fringe) Yes No Depth (inches): _____

Wetland Hydrology Present? Yes No

Describe Recorded Data (stream gauge, monitoring well, aerial photos, previous inspections), if available:

Remarks: No saturation or water table observed in sample plot

WETLAND DETERMINATION DATA FORM – Western Mountains, Valleys, and Coast Region

Project Site: Sound Transit East Link Extension Project City/County: Bellevue/King Sampling Date: Feb. 14, 2013
 Applicant/Owner: Sound Transit State: WA Sampling Point: North Lake SPW
 Investigator(s): C Douglas & J. Pursley Section, Township, Range: S29, T24N, R5E
 Landform (hillslope, terrace, etc.): Narrow area between development Local relief (concave, convex, none): concave Slope (%): 0% to 2%
 Subregion (LRR): A Lat: 47.62N Long: 122.18W Datum: _____
 Soil Map Unit Name: Alderwood gravelly sandy loam NWI classification: None Mapped
 Are climatic / hydrologic conditions on the site typical for this time of year? Yes No (If no, explain in Remarks.)
 Are Vegetation , Soil , or Hydrology , significantly disturbed? Are "Normal Circumstances" present? Yes No
 Are Vegetation , Soil , or Hydrology , naturally problematic? (If needed, explain any answers in Remarks.)

SUMMARY OF FINDINGS – Attach site map showing sampling point locations, transects, important features, etc.

Hydrophytic Vegetation Present?	Yes <input checked="" type="checkbox"/>	No <input type="checkbox"/>	Is the Sampled Area within a Wetland?	Yes <input checked="" type="checkbox"/>	No <input type="checkbox"/>
Hydric Soil Present?	Yes <input checked="" type="checkbox"/>	No <input type="checkbox"/>		Yes <input checked="" type="checkbox"/>	No <input type="checkbox"/>
Wetland Hydrology Present?	Yes <input checked="" type="checkbox"/>	No <input type="checkbox"/>		Yes <input checked="" type="checkbox"/>	No <input type="checkbox"/>
Remarks: Wetland North Lake is located in narrow area between railroad tracks and commercial development. Wetland includes slope HGM class.					

VEGETATION – Use scientific names of plants

Tree Stratum (Plot size: 30 foot radius)	Absolute % Cover	Dominant Species?	Indicator Status	Dominance Test Worksheet:																
1. <u><i>Alnus rubra</i></u>	<u>10</u>	<u>yes</u>	<u>FAC</u>	Number of Dominant Species That Are OBL, FACW, or FAC: <u>3</u> (A) Total Number of Dominant Species Across All Strata: <u>4</u> (B) Percent of Dominant Species That Are OBL, FACW, or FAC: <u>75</u> (A/B)																
2. <u><i>Salix scouleriana</i></u>	<u>40</u>	<u>yes</u>	<u>FAC</u>																	
3. _____	_____	_____	_____																	
4. _____	_____	_____	_____																	
50% = <u>1</u> , 20% = <u>1</u>	<u>50</u>	= Total Cover		Prevalence Index worksheet: <table style="width: 100%; border: none;"> <tr> <td style="text-align: right;">Total % Cover of:</td> <td style="text-align: left;">Multiply by:</td> </tr> <tr> <td>OBL species _____</td> <td>x1 = _____</td> </tr> <tr> <td>FACW species _____</td> <td>x2 = _____</td> </tr> <tr> <td>FAC species _____</td> <td>x3 = _____</td> </tr> <tr> <td>FACU species _____</td> <td>x4 = _____</td> </tr> <tr> <td>UPL species _____</td> <td>x5 = _____</td> </tr> <tr> <td>Column Totals: _____ (A)</td> <td>_____ (B)</td> </tr> <tr> <td colspan="2" style="text-align: center;">Prevalence Index = B/A = _____</td> </tr> </table>	Total % Cover of:	Multiply by:	OBL species _____	x1 = _____	FACW species _____	x2 = _____	FAC species _____	x3 = _____	FACU species _____	x4 = _____	UPL species _____	x5 = _____	Column Totals: _____ (A)	_____ (B)	Prevalence Index = B/A = _____	
Total % Cover of:	Multiply by:																			
OBL species _____	x1 = _____																			
FACW species _____	x2 = _____																			
FAC species _____	x3 = _____																			
FACU species _____	x4 = _____																			
UPL species _____	x5 = _____																			
Column Totals: _____ (A)	_____ (B)																			
Prevalence Index = B/A = _____																				
<u>Sapling/Shrub Stratum (Plot size: 15 foot radius)</u>																				
1. <u><i>Rubus armeniacus</i></u>	<u>15</u>	<u>yes</u>	<u>FACU</u>																	
2. _____	_____	_____	_____																	
3. _____	_____	_____	_____																	
4. _____	_____	_____	_____																	
5. _____	_____	_____	_____																	
50% = <u>1</u> , 20% = <u>0</u>	<u>15</u>	= Total Cover																		
<u>Herb Stratum (Plot size: 3 foot radius)</u>																				
1. <u><i>Epilobium watsonii</i></u>	<u>5</u>	<u>no</u>	<u>FACW</u>	Hydrophytic Vegetation Indicators: <input type="checkbox"/> 1 – Rapid Test for Hydrophytic Vegetation <input checked="" type="checkbox"/> 2 - Dominance Test is >50% <input type="checkbox"/> 3 - Prevalence Index is $\leq 3.0^1$ <input type="checkbox"/> 4 - Morphological Adaptations ¹ (Provide supporting data in Remarks or on a separate sheet) <input type="checkbox"/> 5 - Wetland Non-Vascular Plants ¹ <input type="checkbox"/> Problematic Hydrophytic Vegetation ¹ (Explain) ¹ Indicators of hydric soil and wetland hydrology must be present, unless disturbed or problematic.																
2. <u><i>Juncus effusus</i></u>	<u>15</u>	<u>no</u>	<u>FACW</u>																	
3. <u><i>Phalaris arundinacea</i></u>	<u>80</u>	<u>yes</u>	<u>FACW</u>																	
4. _____	_____	_____	_____																	
5. _____	_____	_____	_____																	
6. _____	_____	_____	_____																	
7. _____	_____	_____	_____																	
8. _____	_____	_____	_____																	
9. _____	_____	_____	_____																	
10. _____	_____	_____	_____																	
11. _____	_____	_____	_____																	
50% = <u>1</u> , 20% = <u>0</u>	<u>100</u>	= Total Cover																		
<u>Woody Vine Stratum (Plot size: 3 foot radius)</u>																				
1. _____	_____	_____	_____																	
2. _____	_____	_____	_____																	
50% = _____, 20% = _____	<u>0</u>	= Total Cover																		
% Bare Ground in Herb Stratum <u>0</u>																				
Hydrophytic Vegetation Present? Yes <input checked="" type="checkbox"/> No <input type="checkbox"/>																				

Remarks: 75% dominant wetland vegetation per the Dominance Test

SOIL

Profile Description: (Describe to the depth needed to document the indicator or confirm the absence of indicators.)								
Depth (inches)	Matrix		Redox Features				Texture	Remarks
	Color (moist)	%	Color (moist)	%	Type ¹	Loc ²		
0 to 5	<u>10YR 2/1</u>	<u>100</u>	<u>None</u>	<u>None</u>	<u>None</u>	<u>None</u>	<u>Loam</u>	<u>w/cobble & angular rock</u>
5 to 8	<u>10YR 3/1</u>	<u>100</u>	<u>None</u>	<u>None</u>	<u>None</u>	<u>None</u>	<u>Loam</u>	<u>w/angular rock</u>
8 to 18+	<u>10YR 5/1</u>	<u>60</u>	<u>10YR 5/6</u>	<u>40</u>	<u>D</u>	<u>M</u>	<u>Sandy clay</u>	<u>w/angular rock</u>
_____	_____	_____	_____	_____	_____	_____	_____	_____
_____	_____	_____	_____	_____	_____	_____	_____	_____
_____	_____	_____	_____	_____	_____	_____	_____	_____
_____	_____	_____	_____	_____	_____	_____	_____	_____
¹ Type: C= Concentration, D=Depletion, RM=Reduced Matrix, CS=Covered or Coated Sand Grains. ² Location: PL=Pore Lining, M=Matrix								
Hydric Soil Indicators: (Applicable to all LRRs, unless otherwise noted.)						Indicators for Problematic Hydric Soils³:		
<input type="checkbox"/> Histosol (A1)			<input checked="" type="checkbox"/> Sandy Redox (S5)			<input type="checkbox"/> 2 cm Muck (A10)		
<input type="checkbox"/> Histic Epipedon (A2)			<input type="checkbox"/> Stripped Matrix (S6)			<input type="checkbox"/> Red Parent Material (TF2)		
<input type="checkbox"/> Black Histic (A3)			<input type="checkbox"/> Loamy Mucky Mineral (F1) (except MLRA 1)			<input type="checkbox"/> Very Shallow Dark Surface (TF12)		
<input type="checkbox"/> Hydrogen Sulfide (A4)			<input type="checkbox"/> Loamy Gleyed Matrix (F2)			<input type="checkbox"/> Other (Explain in Remarks)		
<input type="checkbox"/> Depleted Below Dark Surface (A11)			<input type="checkbox"/> Depleted Matrix (F3)			³ Indicators of hydrophytic vegetation and wetland hydrology must be present, unless disturbed or problematic.		
<input checked="" type="checkbox"/> Thick Dark Surface (A12)			<input type="checkbox"/> Redox Dark Surface (F6)					
<input type="checkbox"/> Sandy Mucky Mineral (S1)			<input type="checkbox"/> Depleted Dark Surface (F7)					
<input type="checkbox"/> Sandy Gleyed Matrix (S4)			<input type="checkbox"/> Redox Depressions (F8)					
Restrictive Layer (if present):					Hydric Soils Present?			
Type: _____					Yes <input checked="" type="checkbox"/> No <input type="checkbox"/>			
Depth (inches): _____								
Remarks: 1 chroma with redox								

HYDROLOGY

Wetland Hydrology Indicators:			
Primary Indicators (minimum of one required; check all that apply)		Secondary Indicators (2 or more required)	
<input type="checkbox"/> Surface Water (A1)	<input checked="" type="checkbox"/> Water-Stained Leaves (B9)	<input type="checkbox"/> Water-Stained Leaves (B9)	
<input checked="" type="checkbox"/> High Water Table (A2)	(except MLRA 1, 2, 4A, and 4B)	(MLRA 1, 2, 4A, and 4B)	
<input checked="" type="checkbox"/> Saturation (A3)	<input type="checkbox"/> Salt Crust (B11)	<input type="checkbox"/> Drainage Patterns (B10)	
<input type="checkbox"/> Water Marks (B1)	<input type="checkbox"/> Aquatic Invertebrates (B13)	<input type="checkbox"/> Dry-Season Water Table (C2)	
<input type="checkbox"/> Sediment Deposits (B2)	<input type="checkbox"/> Hydrogen Sulfide Odor (C1)	<input type="checkbox"/> Saturation Visible on Aerial Imagery (C9)	
<input type="checkbox"/> Drift Deposits (B3)	<input type="checkbox"/> Oxidized Rhizospheres along Living Roots (C3)	<input type="checkbox"/> Geomorphic Position (D2)	
<input type="checkbox"/> Algal Mat or Crust (B4)	<input type="checkbox"/> Presence of Reduced Iron (C4)	<input type="checkbox"/> Shallow Aquitard (D3)	
<input type="checkbox"/> Iron Deposits (B5)	<input type="checkbox"/> Recent Iron Reduction in Tilled Soils (C6)	<input type="checkbox"/> FAC-Neutral Test (D5)	
<input type="checkbox"/> Surface Soil Cracks (B6)	<input type="checkbox"/> Stunted or Stresses Plants (D1) (LRR A)	<input type="checkbox"/> Raised Ant Mounds (D6) (LRR A)	
<input type="checkbox"/> Inundation Visible on Aerial Imagery (B7)	<input type="checkbox"/> Other (Explain in Remarks)	<input type="checkbox"/> Frost-Heave Hummocks (D7)	
<input type="checkbox"/> Sparsely Vegetated Concave Surface (B8)			
Field Observations:		Wetland Hydrology Present?	
Surface Water Present?	Yes <input type="checkbox"/> No <input checked="" type="checkbox"/>	Depth (inches):	_____
Water Table Present?	Yes <input checked="" type="checkbox"/> No <input type="checkbox"/>	Depth (inches):	<u>3 inches</u>
Saturation Present? (includes capillary fringe)	Yes <input checked="" type="checkbox"/> No <input type="checkbox"/>	Depth (inches):	<u>Surface</u>
Describe Recorded Data (stream gauge, monitoring well, aerial photos, previous inspections), if available:			
Remarks: Saturation and water table observed in sample plot			

WETLAND DETERMINATION DATA FORM – Western Mountains, Valleys, and Coast Region

Project Site: Sound Transit East Link Extension Project City/County: Bellevue/King Sampling Date: Feb. 14, 2013
 Applicant/Owner: Sound Transit State: WA Sampling Point: South Lake SPU
 Investigator(s): C Douglas & J. Pursley Section, Township, Range: S29, T24N, R5E
 Landform (hillslope, terrace, etc.): Narrow area between development Local relief (concave, convex, none): concave Slope (%): 0% to 2%
 Subregion (LRR): A Lat: 47.62N Long: 122.18W Datum: _____
 Soil Map Unit Name: Alderwood gravelly sandy loam NWI classification: None Mapped
 Are climatic / hydrologic conditions on the site typical for this time of year? Yes No (If no, explain in Remarks.)
 Are Vegetation , Soil , or Hydrology , significantly disturbed? Are "Normal Circumstances" present? Yes No
 Are Vegetation , Soil , or Hydrology , naturally problematic? (If needed, explain any answers in Remarks.)

SUMMARY OF FINDINGS – Attach site map showing sampling point locations, transects, important features, etc.

Hydrophytic Vegetation Present?	Yes <input checked="" type="checkbox"/>	No <input type="checkbox"/>	Is the Sampled Area within a Wetland?		
Hydric Soil Present?	Yes <input type="checkbox"/>	No <input checked="" type="checkbox"/>		Yes <input type="checkbox"/>	No <input checked="" type="checkbox"/>
Wetland Hydrology Present?	Yes <input type="checkbox"/>	No <input checked="" type="checkbox"/>			
Remarks: Wetland South Lake is located in narrow area between railroad tracks and development on Lake Bellevue. Wetland includes depressional HGM class.					

VEGETATION – Use scientific names of plants

Tree Stratum (Plot size: 30 foot radius)	Absolute % Cover	Dominant Species?	Indicator Status	Dominance Test Worksheet:
1. <u><i>Populus trichocarpa</i></u>	<u>20</u>	<u>yes</u>	<u>FAC</u>	Number of Dominant Species That Are OBL, FACW, or FAC: <u>4</u> (A) Total Number of Dominant Species Across All Strata: <u>7</u> (B) Percent of Dominant Species That Are OBL, FACW, or FAC: <u>57</u> (A/B)
2. <u><i>Salix hookeriana</i></u>	<u>20</u>	<u>yes</u>	<u>FACW</u>	
3. _____	_____	_____	_____	
4. _____	_____	_____	_____	
50% = <u>2</u> , 20% = <u>0</u>	<u>40</u>	= Total Cover		Prevalence Index worksheet: Total % Cover of: _____ Multiply by: OBL species _____ x1 = _____ FACW species _____ x2 = _____ FAC species _____ x3 = _____ FACU species _____ x4 = _____ UPL species _____ x5 = _____ Column Totals: _____ (A) _____ (B) Prevalence Index = B/A = _____
Sapling/Shrub Stratum (Plot size: 15 foot radius)				
1. <u><i>Ilex aquifolium</i></u>	<u>15</u>	<u>yes</u>	<u>FACU</u>	
2. <u><i>Rubus armeniacus</i></u>	<u>30</u>	<u>yes</u>	<u>FACU</u>	
3. _____	_____	_____	_____	
4. _____	_____	_____	_____	
5. _____	_____	_____	_____	
50% = <u>1</u> , 20% = <u>1</u>	<u>45</u>	= Total Cover		
Herb Stratum (Plot size: 3 foot radius)				
1. <u><i>Epilobium watsonii</i></u>	<u>15</u>	<u>yes</u>	<u>FACW</u>	Hydrophytic Vegetation Indicators: <input type="checkbox"/> 1 – Rapid Test for Hydrophytic Vegetation <input checked="" type="checkbox"/> 2 - Dominance Test is >50% <input type="checkbox"/> 3 - Prevalence Index is $\leq 3.0^1$ <input type="checkbox"/> 4 - Morphological Adaptations ¹ (Provide supporting data in Remarks or on a separate sheet) <input type="checkbox"/> 5 - Wetland Non-Vascular Plants ¹ <input type="checkbox"/> Problematic Hydrophytic Vegetation ¹ (Explain) ¹ Indicators of hydric soil and wetland hydrology must be present, unless disturbed or problematic.
2. <u><i>Equisetum arvense</i></u>	<u>15</u>	<u>yes</u>	<u>FAC</u>	
3. _____	_____	_____	_____	
4. _____	_____	_____	_____	
5. _____	_____	_____	_____	
6. _____	_____	_____	_____	
7. _____	_____	_____	_____	
8. _____	_____	_____	_____	
9. _____	_____	_____	_____	
10. _____	_____	_____	_____	
11. _____	_____	_____	_____	
50% = <u>2</u> , 20% = <u>0</u>	<u>30</u>	= Total Cover		
Woody Vine Stratum (Plot size: 3 foot radius)				
1. <u><i>Hedera hibernica</i></u>	<u>100</u>	<u>yes</u>	<u>UPL</u>	Hydrophytic Vegetation Present? Yes <input checked="" type="checkbox"/> No <input type="checkbox"/>
2. _____	_____	_____	_____	
50% = <u>1</u> , 20% = <u>0</u>	<u>100</u>	= Total Cover		
% Bare Ground in Herb Stratum <u>70</u>				

Remarks: 57% dominant wetland vegetation per the Dominance Test

SOIL

Profile Description: (Describe to the depth needed to document the indicator or confirm the absence of indicators.)

Depth (inches)	Matrix		Redox Features				Texture	Remarks
	Color (moist)	%	Color (moist)	%	Type ¹	Loc ²		
0 to 4	10YR 3/3	100	None	None	None	None	Sandy loam	w/gravel
4 to 18+	10YR 3/3	100	None	None	None	None	Sandy loam	w/grave, cobble, & angular rockl
_____	_____	_____	_____	_____	_____	_____	_____	_____
_____	_____	_____	_____	_____	_____	_____	_____	_____
_____	_____	_____	_____	_____	_____	_____	_____	_____
_____	_____	_____	_____	_____	_____	_____	_____	_____
_____	_____	_____	_____	_____	_____	_____	_____	_____

¹Type: C= Concentration, D=Depletion, RM=Reduced Matrix, CS=Covered or Coated Sand Grains. ²Location: PL=Pore Lining, M=Matrix

Hydric Soil Indicators: (Applicable to all LRRs, unless otherwise noted.)

Indicators for Problematic Hydric Soils³:

- | | | |
|--|---|---|
| <input type="checkbox"/> Histosol (A1) | <input type="checkbox"/> Sandy Redox (S5) | <input type="checkbox"/> 2 cm Muck (A10) |
| <input type="checkbox"/> Histic Epipedon (A2) | <input type="checkbox"/> Stripped Matrix (S6) | <input type="checkbox"/> Red Parent Material (TF2) |
| <input type="checkbox"/> Black Histic (A3) | <input type="checkbox"/> Loamy Mucky Mineral (F1) (except MLRA 1) | <input type="checkbox"/> Very Shallow Dark Surface (TF12) |
| <input type="checkbox"/> Hydrogen Sulfide (A4) | <input type="checkbox"/> Loamy Gleyed Matrix (F2) | <input type="checkbox"/> Other (Explain in Remarks) |
| <input type="checkbox"/> Depleted Below Dark Surface (A11) | <input type="checkbox"/> Depleted Matrix (F3) | |
| <input type="checkbox"/> Thick Dark Surface (A12) | <input type="checkbox"/> Redox Dark Surface (F6) | |
| <input type="checkbox"/> Sandy Mucky Mineral (S1) | <input type="checkbox"/> Depleted Dark Surface (F7) | |
| <input type="checkbox"/> Sandy Gleyed Matrix (S4) | <input type="checkbox"/> Redox Depressions (F8) | |

³Indicators of hydrophytic vegetation and wetland hydrology must be present, unless disturbed or problematic.

Restrictive Layer (if present):

Type: _____
 Depth (inches): _____

Hydric Soils Present? Yes No

Remarks: 3 chroma with no redox features

HYDROLOGY

Wetland Hydrology Indicators:

Primary Indicators (minimum of one required; check all that apply)

Secondary Indicators (2 or more required)

- | | | |
|--|--|--|
| <input type="checkbox"/> Surface Water (A1) | <input type="checkbox"/> Water-Stained Leaves (B9) | <input type="checkbox"/> Water-Stained Leaves (B9) |
| <input type="checkbox"/> High Water Table (A2) | (except MLRA 1, 2, 4A, and 4B) | (MLRA 1, 2, 4A, and 4B) |
| <input type="checkbox"/> Saturation (A3) | <input type="checkbox"/> Salt Crust (B11) | <input type="checkbox"/> Drainage Patterns (B10) |
| <input type="checkbox"/> Water Marks (B1) | <input type="checkbox"/> Aquatic Invertebrates (B13) | <input type="checkbox"/> Dry-Season Water Table (C2) |
| <input type="checkbox"/> Sediment Deposits (B2) | <input type="checkbox"/> Hydrogen Sulfide Odor (C1) | <input type="checkbox"/> Saturation Visible on Aerial Imagery (C9) |
| <input type="checkbox"/> Drift Deposits (B3) | <input type="checkbox"/> Oxidized Rhizospheres along Living Roots (C3) | <input type="checkbox"/> Geomorphic Position (D2) |
| <input type="checkbox"/> Algal Mat or Crust (B4) | <input type="checkbox"/> Presence of Reduced Iron (C4) | <input type="checkbox"/> Shallow Aquitard (D3) |
| <input type="checkbox"/> Iron Deposits (B5) | <input type="checkbox"/> Recent Iron Reduction in Tilled Soils (C6) | <input type="checkbox"/> FAC-Neutral Test (D5) |
| <input type="checkbox"/> Surface Soil Cracks (B6) | <input type="checkbox"/> Stunted or Stresses Plants (D1) (LRR A) | <input type="checkbox"/> Raised Ant Mounds (D6) (LRR A) |
| <input type="checkbox"/> Inundation Visible on Aerial Imagery (B7) | <input type="checkbox"/> Other (Explain in Remarks) | <input type="checkbox"/> Frost-Heave Hummocks (D7) |
| <input type="checkbox"/> Sparsely Vegetated Concave Surface (B8) | | |

Field Observations:

Surface Water Present? Yes No Depth (inches): _____
 Water Table Present? Yes No Depth (inches): _____
 Saturation Present?
 (includes capillary fringe) Yes No Depth (inches): _____

Wetland Hydrology Present? Yes No

Describe Recorded Data (stream gauge, monitoring well, aerial photos, previous inspections), if available:

Remarks: No saturation or water table observed in sample plot

WETLAND DETERMINATION DATA FORM – Western Mountains, Valleys, and Coast Region

Project Site: Sound Transit East Link Extension Project City/County: Bellevue/King Sampling Date: Feb. 14, 2013
 Applicant/Owner: Sound Transit State: WA Sampling Point: South Lake SPW
 Investigator(s): C Douglas & J. Pursley Section, Township, Range: S29, T24N, R5E
 Landform (hillslope, terrace, etc.): Narrow area between development Local relief (concave, convex, none): concave Slope (%): 0% to 2%
 Subregion (LRR): A Lat: 47.62N Long: 122.18W Datum: _____
 Soil Map Unit Name: Alderwood gravelly sandy loam NWI classification: None Mapped
 Are climatic / hydrologic conditions on the site typical for this time of year? Yes No (If no, explain in Remarks.)
 Are Vegetation , Soil , or Hydrology , significantly disturbed? Are "Normal Circumstances" present? Yes No
 Are Vegetation , Soil , or Hydrology , naturally problematic? (If needed, explain any answers in Remarks.)

SUMMARY OF FINDINGS – Attach site map showing sampling point locations, transects, important features, etc.

Hydrophytic Vegetation Present?	Yes <input checked="" type="checkbox"/>	No <input type="checkbox"/>	Is the Sampled Area within a Wetland?	Yes <input checked="" type="checkbox"/>	No <input type="checkbox"/>
Hydric Soil Present?	Yes <input checked="" type="checkbox"/>	No <input type="checkbox"/>		Yes <input checked="" type="checkbox"/>	No <input type="checkbox"/>
Wetland Hydrology Present?	Yes <input checked="" type="checkbox"/>	No <input type="checkbox"/>		Yes <input checked="" type="checkbox"/>	No <input type="checkbox"/>
Remarks: Wetland South Lake is located in narrow area between railroad tracks and development on Lake Bellevue. Wetland includes depressional HGM class.					

VEGETATION – Use scientific names of plants

Tree Stratum (Plot size: 30 foot radius)	Absolute % Cover	Dominant Species?	Indicator Status	Dominance Test Worksheet:																
1. <u><i>Salix hookeriana</i></u>	<u>50</u>	<u>yes</u>	<u>FACW</u>	Number of Dominant Species That Are OBL, FACW, or FAC: <u>4</u> (A) Total Number of Dominant Species Across All Strata: <u>6</u> (B) Percent of Dominant Species That Are OBL, FACW, or FAC: <u>67</u> (A/B)																
2. _____	_____	_____	_____																	
3. _____	_____	_____	_____																	
4. _____	_____	_____	_____																	
50% = <u>1</u> , 20% = <u>0</u>	<u>50</u>	= Total Cover																		
Sapling/Shrub Stratum (Plot size: 15 foot radius)				Prevalence Index worksheet: <table style="width: 100%; border: none;"> <tr> <td style="text-align: right;">Total % Cover of:</td> <td style="text-align: left;">Multiply by:</td> </tr> <tr> <td>OBL species _____</td> <td>x1 = _____</td> </tr> <tr> <td>FACW species _____</td> <td>x2 = _____</td> </tr> <tr> <td>FAC species _____</td> <td>x3 = _____</td> </tr> <tr> <td>FACU species _____</td> <td>x4 = _____</td> </tr> <tr> <td>UPL species _____</td> <td>x5 = _____</td> </tr> <tr> <td>Column Totals: _____ (A)</td> <td>_____ (B)</td> </tr> <tr> <td colspan="2" style="text-align: center;">Prevalence Index = B/A = _____</td> </tr> </table>	Total % Cover of:	Multiply by:	OBL species _____	x1 = _____	FACW species _____	x2 = _____	FAC species _____	x3 = _____	FACU species _____	x4 = _____	UPL species _____	x5 = _____	Column Totals: _____ (A)	_____ (B)	Prevalence Index = B/A = _____	
Total % Cover of:	Multiply by:																			
OBL species _____	x1 = _____																			
FACW species _____	x2 = _____																			
FAC species _____	x3 = _____																			
FACU species _____	x4 = _____																			
UPL species _____	x5 = _____																			
Column Totals: _____ (A)	_____ (B)																			
Prevalence Index = B/A = _____																				
1. <u><i>Rubus armeniacus</i></u>	<u>20</u>	<u>yes</u>	<u>FACU</u>																	
2. <u><i>Rubus spectabilis</i></u>	<u>30</u>	<u>yes</u>	<u>FAC</u>																	
3. <u><i>Spiraea douglasii</i></u>	<u>40</u>	<u>yes</u>	<u>FACW</u>																	
4. _____	_____	_____	_____																	
5. _____	_____	_____	_____																	
50% = <u>1</u> , 20% = <u>2</u>	<u>90</u>	= Total Cover																		
Herb Stratum (Plot size: 3 foot radius)																				
1. <u><i>Equisetum telmateia</i></u>	<u>5</u>	<u>no</u>	<u>FACW</u>																	
2. <u><i>Juncus effusus</i></u>	<u>1</u>	<u>yes</u>	<u>FACW</u>																	
3. <u><i>Phalaris arundinacea</i></u>	<u>90</u>	<u>yes</u>	<u>FACW</u>																	
4. _____	_____	_____	_____																	
5. _____	_____	_____	_____																	
6. _____	_____	_____	_____																	
7. _____	_____	_____	_____																	
8. _____	_____	_____	_____																	
9. _____	_____	_____	_____																	
10. _____	_____	_____	_____																	
11. _____	_____	_____	_____																	
50% = <u>1</u> , 20% = <u>0</u>	<u>96</u>	= Total Cover																		
Woody Vine Stratum (Plot size: 3 foot radius)																				
1. <u><i>Hedera hibernica</i></u>	<u>10</u>	<u>yes</u>	<u>UPL</u>																	
2. _____	_____	_____	_____																	
50% = _____, 20% = _____	<u>10</u>	= Total Cover																		
% Bare Ground in Herb Stratum <u>4</u>																				
Hydrophytic Vegetation Indicators: <input type="checkbox"/> 1 – Rapid Test for Hydrophytic Vegetation <input checked="" type="checkbox"/> 2 - Dominance Test is >50% <input type="checkbox"/> 3 - Prevalence Index is $\leq 3.0^1$ <input type="checkbox"/> 4 - Morphological Adaptations ¹ (Provide supporting data in Remarks or on a separate sheet) <input type="checkbox"/> 5 - Wetland Non-Vascular Plants ¹ <input type="checkbox"/> Problematic Hydrophytic Vegetation ¹ (Explain)																				
¹ Indicators of hydric soil and wetland hydrology must be present, unless disturbed or problematic.																				
Hydrophytic Vegetation Present? Yes <input checked="" type="checkbox"/> No <input type="checkbox"/>																				

Remarks: 67% dominant wetland vegetation per the Dominance Test

SOIL

Profile Description: (Describe to the depth needed to document the indicator or confirm the absence of indicators.)

Depth (inches)	Matrix		Redox Features				Texture	Remarks
	Color (moist)	%	Color (moist)	%	Type ¹	Loc ²		
0 to 3	10YR 3/2	100	None	None	None	None	Silt	w/roots throughout
3 to 18+	10YR 2/1	100	None	None	None	None	Loam	w/roots throughout
_____	_____	_____	_____	_____	_____	_____	_____	_____
_____	_____	_____	_____	_____	_____	_____	_____	_____
_____	_____	_____	_____	_____	_____	_____	_____	_____
_____	_____	_____	_____	_____	_____	_____	_____	_____
_____	_____	_____	_____	_____	_____	_____	_____	_____

¹Type: C= Concentration, D=Depletion, RM=Reduced Matrix, CS=Covered or Coated Sand Grains. ²Location: PL=Pore Lining, M=Matrix

Hydric Soil Indicators: (Applicable to all LRRs, unless otherwise noted.)

- Histosol (A1)
- Histic Epipedon (A2)
- Black Histic (A3)
- Hydrogen Sulfide (A4)
- Depleted Below Dark Surface (A11)
- Thick Dark Surface (A12)
- Sandy Mucky Mineral (S1)
- Sandy Gleyed Matrix (S4)
- Sandy Redox (S5)
- Stripped Matrix (S6)
- Loamy Mucky Mineral (F1) **(except MLRA 1)**
- Loamy Gleyed Matrix (F2)
- Depleted Matrix (F3)
- Redox Dark Surface (F6)
- Depleted Dark Surface (F7)
- Redox Depressions (F8)

Indicators for Problematic Hydric Soils³:

- 2 cm Muck (A10)
- Red Parent Material (TF2)
- Very Shallow Dark Surface (TF12)
- Other (Explain in Remarks)

³Indicators of hydrophytic vegetation and wetland hydrology must be present, unless disturbed or problematic.

Restrictive Layer (if present):

Type: _____
 Depth (inches): _____

Hydric Soils Present? Yes No

Remarks: 1 and 2 chroma

HYDROLOGY

Wetland Hydrology Indicators:

Primary Indicators (minimum of one required; check all that apply)

- Surface Water (A1)
- High Water Table (A2)
- Saturation (A3)
- Water Marks (B1)
- Sediment Deposits (B2)
- Drift Deposits (B3)
- Algal Mat or Crust (B4)
- Iron Deposits (B5)
- Surface Soil Cracks (B6)
- Inundation Visible on Aerial Imagery (B7)
- Sparsely Vegetated Concave Surface (B8)
- Water-Stained Leaves (B9) **(except MLRA 1, 2, 4A, and 4B)**
- Salt Crust (B11)
- Aquatic Invertebrates (B13)
- Hydrogen Sulfide Odor (C1)
- Oxidized Rhizospheres along Living Roots (C3)
- Presence of Reduced Iron (C4)
- Recent Iron Reduction in Tilled Soils (C6)
- Stunted or Stresses Plants (D1) **(LRR A)**
- Other (Explain in Remarks)

Secondary Indicators (2 or more required)

- Water-Stained Leaves (B9) **(MLRA 1, 2, 4A, and 4B)**
- Drainage Patterns (B10)
- Dry-Season Water Table (C2)
- Saturation Visible on Aerial Imagery (C9)
- Geomorphic Position (D2)
- Shallow Aquitard (D3)
- FAC-Neutral Test (D5)
- Raised Ant Mounds (D6) **(LRR A)**
- Frost-Heave Hummocks (D7)

Field Observations:

Surface Water Present? Yes No Depth (inches): _____
 Water Table Present? Yes No Depth (inches): 1 inch
 Saturation Present? (includes capillary fringe) Yes No Depth (inches): Surface

Wetland Hydrology Present? Yes No

Describe Recorded Data (stream gauge, monitoring well, aerial photos, previous inspections), if available:

Remarks: Saturation and water table observed in sample plot

WETLAND DETERMINATION DATA FORM – Western Mountains, Valleys, and Coast Region

Project Site: Sound Transit East Link Extension Project City/County: Bellevue/King Sampling Date: Feb. 28, 2013
 Applicant/Owner: Sound Transit State: WA Sampling Point: SR 520 East SP2U
 Investigator(s): C Douglas & J. Pursley Section, Township, Range: S28, T24N, R5E
 Landform (hillslope, terrace, etc.): Narrow area between development Local relief (concave, convex, none): concave Slope (%): 0% to 2%
 Subregion (LRR): A Lat: 47.62N Long: 122.15W Datum: _____
 Soil Map Unit Name: Bellingham silt loam & Shalcar muck NWI classification: None Mapped
 Are climatic / hydrologic conditions on the site typical for this time of year? Yes No (If no, explain in Remarks.)
 Are Vegetation , Soil , or Hydrology , significantly disturbed? Are "Normal Circumstances" present? Yes No
 Are Vegetation , Soil , or Hydrology , naturally problematic? (If needed, explain any answers in Remarks.)

SUMMARY OF FINDINGS – Attach site map showing sampling point locations, transects, important features, etc.

Hydrophytic Vegetation Present?	Yes <input type="checkbox"/>	No <input checked="" type="checkbox"/>	Is the Sampled Area within a Wetland?	Yes <input type="checkbox"/>	No <input checked="" type="checkbox"/>
Hydric Soil Present?	Yes <input type="checkbox"/>	No <input checked="" type="checkbox"/>		Yes <input type="checkbox"/>	No <input checked="" type="checkbox"/>
Wetland Hydrology Present?	Yes <input type="checkbox"/>	No <input checked="" type="checkbox"/>		Yes <input type="checkbox"/>	No <input checked="" type="checkbox"/>
Remarks: Wetland SR 520 East is located in narrow area between commercial development and the SR 520 ROW fill prism. Wetland is a narrow depression with culverts at both ends. Wetland includes slope HGM class. Wetland is connected to Wetland Valley Creek via a jurisdictional ditch.					

VEGETATION – Use scientific names of plants

Tree Stratum (Plot size: 30 foot radius)	Absolute % Cover	Dominant Species?	Indicator Status	Dominance Test Worksheet:																
1. <u><i>Pseudotsuga menziesii</i></u>	<u>95</u>	<u>yes</u>	<u>FACU</u>	Number of Dominant Species That Are OBL, FACW, or FAC: <u>1</u> (A) Total Number of Dominant Species Across All Strata: <u>3</u> (B) Percent of Dominant Species That Are OBL, FACW, or FAC: <u>34</u> (A/B)																
2. _____	_____	_____	_____																	
3. _____	_____	_____	_____																	
4. _____	_____	_____	_____																	
50% = <u>1</u> , 20% = <u>0</u>	<u>95</u>	= Total Cover																		
<u>Sapling/Shrub Stratum (Plot size: 15 foot radius)</u>																				
1. <u><i>Rubus armeniacus</i></u>	<u>10</u>	<u>yes</u>	<u>FACU</u>	Prevalence Index worksheet: <table style="width: 100%; border: none;"> <tr> <td style="text-align: right;">Total % Cover of:</td> <td style="text-align: left;">Multiply by:</td> </tr> <tr> <td>OBL species _____</td> <td>x1 = _____</td> </tr> <tr> <td>FACW species _____</td> <td>x2 = _____</td> </tr> <tr> <td>FAC species _____</td> <td>x3 = _____</td> </tr> <tr> <td>FACU species _____</td> <td>x4 = _____</td> </tr> <tr> <td>UPL species _____</td> <td>x5 = _____</td> </tr> <tr> <td>Column Totals: _____ (A)</td> <td>_____ (B)</td> </tr> <tr> <td colspan="2" style="text-align: center;">Prevalence Index = B/A = _____</td> </tr> </table>	Total % Cover of:	Multiply by:	OBL species _____	x1 = _____	FACW species _____	x2 = _____	FAC species _____	x3 = _____	FACU species _____	x4 = _____	UPL species _____	x5 = _____	Column Totals: _____ (A)	_____ (B)	Prevalence Index = B/A = _____	
Total % Cover of:	Multiply by:																			
OBL species _____	x1 = _____																			
FACW species _____	x2 = _____																			
FAC species _____	x3 = _____																			
FACU species _____	x4 = _____																			
UPL species _____	x5 = _____																			
Column Totals: _____ (A)	_____ (B)																			
Prevalence Index = B/A = _____																				
2. _____	_____	_____	_____																	
3. _____	_____	_____	_____																	
4. _____	_____	_____	_____																	
5. _____	_____	_____	_____																	
50% = <u>1</u> , 20% = <u>0</u>	<u>10</u>	= Total Cover																		
<u>Herb Stratum (Plot size: 3 foot radius)</u>																				
1. <u><i>Equisetum arvense</i></u>	<u>60</u>	<u>yes</u>	<u>FAC</u>	Hydrophytic Vegetation Indicators: <input type="checkbox"/> 1 – Rapid Test for Hydrophytic Vegetation <input checked="" type="checkbox"/> 2 - Dominance Test is >50% <input type="checkbox"/> 3 - Prevalence Index is $\leq 3.0^1$ <input type="checkbox"/> 4 - Morphological Adaptations ¹ (Provide supporting data in Remarks or on a separate sheet) <input type="checkbox"/> 5 - Wetland Non-Vascular Plants ¹ <input type="checkbox"/> Problematic Hydrophytic Vegetation ¹ (Explain) ¹ Indicators of hydric soil and wetland hydrology must be present, unless disturbed or problematic.																
2. _____	_____	_____	_____																	
3. _____	_____	_____	_____																	
4. _____	_____	_____	_____																	
5. _____	_____	_____	_____																	
6. _____	_____	_____	_____																	
7. _____	_____	_____	_____																	
8. _____	_____	_____	_____																	
9. _____	_____	_____	_____																	
10. _____	_____	_____	_____																	
11. _____	_____	_____	_____																	
50% = <u>1</u> , 20% = <u>0</u>	<u>60</u>	= Total Cover																		
<u>Woody Vine Stratum (Plot size: 3 foot radius)</u>																				
1. _____	_____	_____	_____	Hydrophytic Vegetation Present?																
2. _____	_____	_____	_____		Yes <input type="checkbox"/> No <input checked="" type="checkbox"/>															
50% = _____, 20% = _____	<u>0</u>	= Total Cover																		
% Bare Ground in Herb Stratum <u>40</u>																				

Remarks: 34% dominant wetland vegetation per the Dominance Test.

SOIL

Profile Description: (Describe to the depth needed to document the indicator or confirm the absence of indicators.)								
Depth (inches)	Matrix		Redox Features				Texture	Remarks
	Color (moist)	%	Color (moist)	%	Type ¹	Loc ²		
0 to 8	<u>10YR 3/3</u>	<u>100</u>	<u>None</u>	<u>None</u>	<u>None</u>	<u>None</u>	<u>Sandy loam</u>	<u>w/gravel</u>
8 to 18+	<u>10YR 4/3</u>	<u>100</u>	<u>None</u>	<u>None</u>	<u>None</u>	<u>None</u>	<u>Loamy sand</u>	<u>w/angular rock</u>
_____	_____	_____	_____	_____	_____	_____	_____	_____
_____	_____	_____	_____	_____	_____	_____	_____	_____
_____	_____	_____	_____	_____	_____	_____	_____	_____
_____	_____	_____	_____	_____	_____	_____	_____	_____
_____	_____	_____	_____	_____	_____	_____	_____	_____

¹Type: C= Concentration, D=Depletion, RM=Reduced Matrix, CS=Covered or Coated Sand Grains. ²Location: PL=Pore Lining, M=Matrix

Hydric Soil Indicators: (Applicable to all LRRs, unless otherwise noted.)		Indicators for Problematic Hydric Soils³:	
<input type="checkbox"/> Histosol (A1)	<input type="checkbox"/> Sandy Redox (S5)	<input type="checkbox"/> 2 cm Muck (A10)	
<input type="checkbox"/> Histic Epipedon (A2)	<input type="checkbox"/> Stripped Matrix (S6)	<input type="checkbox"/> Red Parent Material (TF2)	
<input type="checkbox"/> Black Histic (A3)	<input type="checkbox"/> Loamy Mucky Mineral (F1) (except MLRA 1)	<input type="checkbox"/> Very Shallow Dark Surface (TF12)	
<input type="checkbox"/> Hydrogen Sulfide (A4)	<input type="checkbox"/> Loamy Gleyed Matrix (F2)	<input type="checkbox"/> Other (Explain in Remarks)	
<input type="checkbox"/> Depleted Below Dark Surface (A11)	<input type="checkbox"/> Depleted Matrix (F3)		
<input type="checkbox"/> Thick Dark Surface (A12)	<input type="checkbox"/> Redox Dark Surface (F6)		
<input type="checkbox"/> Sandy Mucky Mineral (S1)	<input type="checkbox"/> Depleted Dark Surface (F7)		
<input type="checkbox"/> Sandy Gleyed Matrix (S4)	<input type="checkbox"/> Redox Depressions (F8)		

³Indicators of hydrophytic vegetation and wetland hydrology must be present, unless disturbed or problematic.

Restrictive Layer (if present): Type: _____ Depth (inches): _____		Hydric Soils Present? Yes <input type="checkbox"/> No <input checked="" type="checkbox"/>
Remarks: 3 chroma		

HYDROLOGY

Wetland Hydrology Indicators: Primary Indicators (minimum of one required; check all that apply)		Secondary Indicators (2 or more required)	
<input type="checkbox"/> Surface Water (A1)	<input type="checkbox"/> Water-Stained Leaves (B9)	<input type="checkbox"/> Water-Stained Leaves (B9)	
<input type="checkbox"/> High Water Table (A2)	(except MLRA 1, 2, 4A, and 4B)	(MLRA 1, 2, 4A, and 4B)	
<input type="checkbox"/> Saturation (A3)	<input type="checkbox"/> Salt Crust (B11)	<input type="checkbox"/> Drainage Patterns (B10)	
<input type="checkbox"/> Water Marks (B1)	<input type="checkbox"/> Aquatic Invertebrates (B13)	<input type="checkbox"/> Dry-Season Water Table (C2)	
<input type="checkbox"/> Sediment Deposits (B2)	<input type="checkbox"/> Hydrogen Sulfide Odor (C1)	<input type="checkbox"/> Saturation Visible on Aerial Imagery (C9)	
<input type="checkbox"/> Drift Deposits (B3)	<input type="checkbox"/> Oxidized Rhizospheres along Living Roots (C3)	<input type="checkbox"/> Geomorphic Position (D2)	
<input type="checkbox"/> Algal Mat or Crust (B4)	<input type="checkbox"/> Presence of Reduced Iron (C4)	<input type="checkbox"/> Shallow Aquitard (D3)	
<input type="checkbox"/> Iron Deposits (B5)	<input type="checkbox"/> Recent Iron Reduction in Tilled Soils (C6)	<input type="checkbox"/> FAC-Neutral Test (D5)	
<input type="checkbox"/> Surface Soil Cracks (B6)	<input type="checkbox"/> Stunted or Stresses Plants (D1) (LRR A)	<input type="checkbox"/> Raised Ant Mounds (D6) (LRR A)	
<input type="checkbox"/> Inundation Visible on Aerial Imagery (B7)	<input type="checkbox"/> Other (Explain in Remarks)	<input type="checkbox"/> Frost-Heave Hummocks (D7)	
<input type="checkbox"/> Sparsely Vegetated Concave Surface (B8)			

Field Observations: Surface Water Present? Yes <input type="checkbox"/> No <input checked="" type="checkbox"/> Depth (inches): _____ Water Table Present? Yes <input type="checkbox"/> No <input checked="" type="checkbox"/> Depth (inches): _____ Saturation Present? (includes capillary fringe) Yes <input type="checkbox"/> No <input checked="" type="checkbox"/> Depth (inches): _____		Wetland Hydrology Present? Yes <input type="checkbox"/> No <input checked="" type="checkbox"/>
Describe Recorded Data (stream gauge, monitoring well, aerial photos, previous inspections), if available:		
Remarks: No saturation or water table observed in sample plot		

WETLAND DETERMINATION DATA FORM – Western Mountains, Valleys, and Coast Region

Project Site: Sound Transit East Link Extension Project City/County: Bellevue/King Sampling Date: May 15, 2013
 Applicant/Owner: Sound Transit State: WA Sampling Point: SR 520 East SPU
 Investigator(s): C Douglas & J. Pursley Section, Township, Range: S28, T24N, R5E
 Landform (hillslope, terrace, etc.): Narrow area between development Local relief (concave, convex, none): concave Slope (%): 0% to 2%
 Subregion (LRR): A Lat: 47.62N Long: 122.15W Datum: _____
 Soil Map Unit Name: Bellingham silt loam & Alderwood gravely sandy loam NWI classification: None Mapped
 Are climatic / hydrologic conditions on the site typical for this time of year? Yes No (If no, explain in Remarks.)
 Are Vegetation , Soil , or Hydrology , significantly disturbed? Are "Normal Circumstances" present? Yes No
 Are Vegetation , Soil , or Hydrology , naturally problematic? (If needed, explain any answers in Remarks.)

SUMMARY OF FINDINGS – Attach site map showing sampling point locations, transects, important features, etc.

Hydrophytic Vegetation Present?	Yes <input type="checkbox"/>	No <input checked="" type="checkbox"/>	Is the Sampled Area within a Wetland?	Yes <input type="checkbox"/>	No <input checked="" type="checkbox"/>
Hydric Soil Present?	Yes <input type="checkbox"/>	No <input checked="" type="checkbox"/>		Yes <input type="checkbox"/>	No <input checked="" type="checkbox"/>
Wetland Hydrology Present?	Yes <input type="checkbox"/>	No <input checked="" type="checkbox"/>		Yes <input type="checkbox"/>	No <input checked="" type="checkbox"/>
Remarks: Wetland SR 520 East is located in narrow area between commercial development and the SR 520 ROW fill prism. Wetland is a narrow depression with culverts at both ends. Wetland includes slope HGM class. Wetland is connected to Wetland Valley Creek via a jurisdictional ditch.					

VEGETATION – Use scientific names of plants

Tree Stratum (Plot size: 30 foot radius)	Absolute % Cover	Dominant Species?	Indicator Status	Dominance Test Worksheet:																																
1. <u><i>Pseudotsuga menziesii</i></u>	35	yes	FACU	Number of Dominant Species That Are OBL, FACW, or FAC: 1 (A) Total Number of Dominant Species Across All Strata: 6 (B) Percent of Dominant Species That Are OBL, FACW, or FAC: 17 (A/B)																																
2. <u><i>Thuja plicata</i></u>	55	yes	FAC																																	
3. _____	_____	_____	_____																																	
4. _____	_____	_____	_____																																	
50% = 1, 20% = 1	90	= Total Cover																																		
Sapling/Shrub Stratum (Plot size: 15 foot radius)	Absolute % Cover	Dominant Species?	Indicator Status	Prevalence Index worksheet:																																
1. <u><i>Oemleria cerasiformis</i></u>	10	yes	FACU	<table style="width: 100%; border: none;"> <tr> <td style="text-align: right;">Total % Cover of:</td> <td style="width: 10%;"></td> <td style="text-align: right;">Multiply by:</td> <td style="width: 10%;"></td> </tr> <tr> <td>OBL species</td> <td style="text-align: center;">_____</td> <td>x1 =</td> <td style="text-align: center;">_____</td> </tr> <tr> <td>FACW species</td> <td style="text-align: center;">_____</td> <td>x2 =</td> <td style="text-align: center;">_____</td> </tr> <tr> <td>FAC species</td> <td style="text-align: center;">_____</td> <td>x3 =</td> <td style="text-align: center;">_____</td> </tr> <tr> <td>FACU species</td> <td style="text-align: center;">_____</td> <td>x4 =</td> <td style="text-align: center;">_____</td> </tr> <tr> <td>UPL species</td> <td style="text-align: center;">_____</td> <td>x5 =</td> <td style="text-align: center;">_____</td> </tr> <tr> <td>Column Totals:</td> <td style="text-align: center;">_____ (A)</td> <td></td> <td style="text-align: center;">_____ (B)</td> </tr> <tr> <td colspan="4" style="text-align: center;">Prevalence Index = B/A = _____</td> </tr> </table>	Total % Cover of:		Multiply by:		OBL species	_____	x1 =	_____	FACW species	_____	x2 =	_____	FAC species	_____	x3 =	_____	FACU species	_____	x4 =	_____	UPL species	_____	x5 =	_____	Column Totals:	_____ (A)		_____ (B)	Prevalence Index = B/A = _____			
Total % Cover of:		Multiply by:																																		
OBL species	_____	x1 =	_____																																	
FACW species	_____	x2 =	_____																																	
FAC species	_____	x3 =	_____																																	
FACU species	_____	x4 =	_____																																	
UPL species	_____	x5 =	_____																																	
Column Totals:	_____ (A)		_____ (B)																																	
Prevalence Index = B/A = _____																																				
2. <u><i>Rubus armeniacus</i></u>	35	yes	FACU																																	
3. _____	_____	_____	_____																																	
4. _____	_____	_____	_____																																	
5. _____	_____	_____	_____																																	
50% = 1, 20% = 1	45	= Total Cover																																		
Herb Stratum (Plot size: 3 foot radius)	Absolute % Cover	Dominant Species?	Indicator Status	Hydrophytic Vegetation Indicators:																																
1. <u><i>Geranium robertianum</i></u>	5	yes	UPL	<input type="checkbox"/> 1 – Rapid Test for Hydrophytic Vegetation <input checked="" type="checkbox"/> 2 - Dominance Test is >50% <input type="checkbox"/> 3 - Prevalence Index is $\leq 3.0^1$ <input type="checkbox"/> 4 - Morphological Adaptations ¹ (Provide supporting data in Remarks or on a separate sheet) <input type="checkbox"/> 5 - Wetland Non-Vascular Plants ¹ <input type="checkbox"/> Problematic Hydrophytic Vegetation ¹ (Explain) ¹ Indicators of hydric soil and wetland hydrology must be present, unless disturbed or problematic.																																
2. _____	_____	_____	_____																																	
3. _____	_____	_____	_____																																	
4. _____	_____	_____	_____																																	
5. _____	_____	_____	_____																																	
6. _____	_____	_____	_____																																	
7. _____	_____	_____	_____																																	
8. _____	_____	_____	_____																																	
9. _____	_____	_____	_____																																	
10. _____	_____	_____	_____																																	
11. _____	_____	_____	_____																																	
50% = 1, 20% = 0	5	= Total Cover																																		
Woody Vine Stratum (Plot size: 3 foot radius)	Absolute % Cover	Dominant Species?	Indicator Status	Hydrophytic Vegetation Present?																																
1. <u><i>Hedera hibernica</i></u>	15	yes	UPL	Yes <input type="checkbox"/> No <input checked="" type="checkbox"/>																																
2. _____	_____	_____	_____																																	
50% = 1, 20% = 0	15	= Total Cover																																		
% Bare Ground in Herb Stratum <u>95</u>																																				

Remarks: 17% dominant wetland vegetation per the Dominance Test.

SOIL

Profile Description: (Describe to the depth needed to document the indicator or confirm the absence of indicators.)								
Depth (inches)	Matrix		Redox Features				Texture	Remarks
	Color (moist)	%	Color (moist)	%	Type ¹	Loc ²		
0 to 6	10YR 4/4	100	None	None	None	None	Sandy loam	
6 to 18+	10YR 4/4	100	None	None	None	None	Sandy loam w/gravel	
_____	_____	_____	_____	_____	_____	_____	_____	_____
_____	_____	_____	_____	_____	_____	_____	_____	_____
_____	_____	_____	_____	_____	_____	_____	_____	_____
_____	_____	_____	_____	_____	_____	_____	_____	_____
_____	_____	_____	_____	_____	_____	_____	_____	_____

¹Type: C= Concentration, D=Depletion, RM=Reduced Matrix, CS=Covered or Coated Sand Grains. ²Location: PL=Pore Lining, M=Matrix

Hydric Soil Indicators: (Applicable to all LRRs, unless otherwise noted.)				Indicators for Problematic Hydric Soils ³ :	
<input type="checkbox"/>	Histosol (A1)	<input type="checkbox"/>	Sandy Redox (S5)	<input type="checkbox"/>	2 cm Muck (A10)
<input type="checkbox"/>	Histic Epipedon (A2)	<input type="checkbox"/>	Stripped Matrix (S6)	<input type="checkbox"/>	Red Parent Material (TF2)
<input type="checkbox"/>	Black Histic (A3)	<input type="checkbox"/>	Loamy Mucky Mineral (F1) (except MLRA 1)	<input type="checkbox"/>	Very Shallow Dark Surface (TF12)
<input type="checkbox"/>	Hydrogen Sulfide (A4)	<input type="checkbox"/>	Loamy Gleyed Matrix (F2)	<input type="checkbox"/>	Other (Explain in Remarks)
<input type="checkbox"/>	Depleted Below Dark Surface (A11)	<input type="checkbox"/>	Depleted Matrix (F3)		
<input type="checkbox"/>	Thick Dark Surface (A12)	<input type="checkbox"/>	Redox Dark Surface (F6)		
<input type="checkbox"/>	Sandy Mucky Mineral (S1)	<input type="checkbox"/>	Depleted Dark Surface (F7)		
<input type="checkbox"/>	Sandy Gleyed Matrix (S4)	<input type="checkbox"/>	Redox Depressions (F8)		

³Indicators of hydrophytic vegetation and wetland hydrology must be present, unless disturbed or problematic.

Restrictive Layer (if present): Type: _____ Depth (inches): _____	Hydric Soils Present? Yes <input type="checkbox"/> No <input checked="" type="checkbox"/>
--	--

Remarks: 3 chroma

HYDROLOGY

Wetland Hydrology Indicators:			
Primary Indicators (minimum of one required; check all that apply)		Secondary Indicators (2 or more required)	
<input type="checkbox"/>	Surface Water (A1)	<input type="checkbox"/>	Water-Stained Leaves (B9)
<input type="checkbox"/>	High Water Table (A2)	<input type="checkbox"/>	(except MLRA 1, 2, 4A, and 4B)
<input type="checkbox"/>	Saturation (A3)	<input type="checkbox"/>	Salt Crust (B11)
<input type="checkbox"/>	Water Marks (B1)	<input type="checkbox"/>	Aquatic Invertebrates (B13)
<input type="checkbox"/>	Sediment Deposits (B2)	<input type="checkbox"/>	Hydrogen Sulfide Odor (C1)
<input type="checkbox"/>	Drift Deposits (B3)	<input type="checkbox"/>	Oxidized Rhizospheres along Living Roots (C3)
<input type="checkbox"/>	Algal Mat or Crust (B4)	<input type="checkbox"/>	Presence of Reduced Iron (C4)
<input type="checkbox"/>	Iron Deposits (B5)	<input type="checkbox"/>	Recent Iron Reduction in Tilled Soils (C6)
<input type="checkbox"/>	Surface Soil Cracks (B6)	<input type="checkbox"/>	Stunted or Stresses Plants (D1) (LRR A)
<input type="checkbox"/>	Inundation Visible on Aerial Imagery (B7)	<input type="checkbox"/>	Other (Explain in Remarks)
<input type="checkbox"/>	Sparsely Vegetated Concave Surface (B8)	<input type="checkbox"/>	Water-Stained Leaves (B9)
		<input type="checkbox"/>	(MLRA 1, 2, 4A, and 4B)
		<input type="checkbox"/>	Drainage Patterns (B10)
		<input type="checkbox"/>	Dry-Season Water Table (C2)
		<input type="checkbox"/>	Saturation Visible on Aerial Imagery (C9)
		<input type="checkbox"/>	Geomorphic Position (D2)
		<input type="checkbox"/>	Shallow Aquitard (D3)
		<input type="checkbox"/>	FAC-Neutral Test (D5)
		<input type="checkbox"/>	Raised Ant Mounds (D6) (LRR A)
		<input type="checkbox"/>	Frost-Heave Hummocks (D7)

Field Observations: Surface Water Present? Yes <input type="checkbox"/> No <input checked="" type="checkbox"/> Depth (inches): _____ Water Table Present? Yes <input type="checkbox"/> No <input checked="" type="checkbox"/> Depth (inches): _____ Saturation Present? Yes <input type="checkbox"/> No <input checked="" type="checkbox"/> Depth (inches): _____ (includes capillary fringe)	Wetland Hydrology Present? Yes <input type="checkbox"/> No <input checked="" type="checkbox"/>
---	---

Describe Recorded Data (stream gauge, monitoring well, aerial photos, previous inspections), if available:

Remarks: No saturation or water table observed in sample plot

WETLAND DETERMINATION DATA FORM – Western Mountains, Valleys, and Coast Region

Project Site: Sound Transit East Link Extension Project City/County: Bellevue/King Sampling Date: Feb. 28, 2013
 Applicant/Owner: Sound Transit State: WA Sampling Point: SR 520 West SP1W
 Investigator(s): C Douglas & J. Pursley Section, Township, Range: S28, T24N, R5E
 Landform (hillslope, terrace, etc.): Narrow area between development Local relief (concave, convex, none): concave Slope (%): 0% to 2%
 Subregion (LRR): A Lat: 47.62N Long: 122.15W Datum: _____
 Soil Map Unit Name: Bellingham silt loam & Shalcar muck NWI classification: None Mapped
 Are climatic / hydrologic conditions on the site typical for this time of year? Yes No (If no, explain in Remarks.)
 Are Vegetation , Soil , or Hydrology , significantly disturbed? Are "Normal Circumstances" present? Yes No
 Are Vegetation , Soil , or Hydrology , naturally problematic? (If needed, explain any answers in Remarks.)

SUMMARY OF FINDINGS – Attach site map showing sampling point locations, transects, important features, etc.

Hydrophytic Vegetation Present?	Yes <input checked="" type="checkbox"/>	No <input type="checkbox"/>	Is the Sampled Area within a Wetland?	Yes <input checked="" type="checkbox"/>	No <input type="checkbox"/>
Hydric Soil Present?	Yes <input checked="" type="checkbox"/>	No <input type="checkbox"/>		Yes <input checked="" type="checkbox"/>	No <input type="checkbox"/>
Wetland Hydrology Present?	Yes <input checked="" type="checkbox"/>	No <input type="checkbox"/>		Yes <input checked="" type="checkbox"/>	No <input type="checkbox"/>
Remarks: Wetland is located in narrow area between commercial development and the SR 520 ROW fill prism. Wetland is a narrow depression with culverts at both ends. Wetland includes depression and slope HGM classes.					

VEGETATION – Use scientific names of plants

Tree Stratum (Plot size: 30 foot radius)	Absolute % Cover	Dominant Species?	Indicator Status	Dominance Test Worksheet:																
1. <u><i>Salix lasiandra</i></u>	40	yes	FACW	Number of Dominant Species That Are OBL, FACW, or FAC: <u>4</u> (A) Total Number of Dominant Species Across All Strata: <u>4</u> (B) Percent of Dominant Species That Are OBL, FACW, or FAC: <u>100</u> (A/B)																
2. _____	_____	_____	_____																	
3. _____	_____	_____	_____																	
4. _____	_____	_____	_____																	
50% = <u>1</u> , 20% = <u>0</u>	1	= Total Cover																		
<u>Sapling/Shrub Stratum (Plot size: 15 foot radius)</u>				Prevalence Index worksheet: <table style="width: 100%; border: none;"> <tr> <td style="text-align: right;">Total % Cover of:</td> <td style="text-align: right;">Multiply by:</td> </tr> <tr> <td>OBL species _____</td> <td>x1 = _____</td> </tr> <tr> <td>FACW species _____</td> <td>x2 = _____</td> </tr> <tr> <td>FAC species _____</td> <td>x3 = _____</td> </tr> <tr> <td>FACU species _____</td> <td>x4 = _____</td> </tr> <tr> <td>UPL species _____</td> <td>x5 = _____</td> </tr> <tr> <td>Column Totals: _____ (A)</td> <td>_____ (B)</td> </tr> <tr> <td colspan="2" style="text-align: center;">Prevalence Index = B/A = _____</td> </tr> </table>	Total % Cover of:	Multiply by:	OBL species _____	x1 = _____	FACW species _____	x2 = _____	FAC species _____	x3 = _____	FACU species _____	x4 = _____	UPL species _____	x5 = _____	Column Totals: _____ (A)	_____ (B)	Prevalence Index = B/A = _____	
Total % Cover of:	Multiply by:																			
OBL species _____	x1 = _____																			
FACW species _____	x2 = _____																			
FAC species _____	x3 = _____																			
FACU species _____	x4 = _____																			
UPL species _____	x5 = _____																			
Column Totals: _____ (A)	_____ (B)																			
Prevalence Index = B/A = _____																				
1. <u><i>Spiraea douglasii</i></u>	20	yes	FACW																	
2. _____	_____	_____	_____																	
3. _____	_____	_____	_____																	
4. _____	_____	_____	_____																	
5. _____	_____	_____	_____																	
50% = <u>1</u> , 20% = <u>0</u>	1	= Total Cover																		
<u>Herb Stratum (Plot size: 3 foot radius)</u>				Hydrophytic Vegetation Indicators: <input type="checkbox"/> 1 – Rapid Test for Hydrophytic Vegetation <input checked="" type="checkbox"/> 2 - Dominance Test is >50% <input type="checkbox"/> 3 - Prevalence Index is $\leq 3.0^1$ <input type="checkbox"/> 4 - Morphological Adaptations ¹ (Provide supporting data in Remarks or on a separate sheet) <input type="checkbox"/> 5 - Wetland Non-Vascular Plants ¹ <input type="checkbox"/> Problematic Hydrophytic Vegetation ¹ (Explain) ¹ Indicators of hydric soil and wetland hydrology must be present, unless disturbed or problematic.																
1. <u><i>Epilobium watsonii</i></u>	5	no	FACW																	
2. <u><i>Oenanthe sarmentosa</i></u>	90	yes	OBL																	
3. _____	_____	_____	_____																	
4. _____	_____	_____	_____																	
5. _____	_____	_____	_____																	
6. _____	_____	_____	_____																	
7. _____	_____	_____	_____																	
8. _____	_____	_____	_____																	
9. _____	_____	_____	_____																	
10. _____	_____	_____	_____																	
11. _____	_____	_____	_____																	
50% = <u>0</u> , 20% = <u>3</u>	100	= Total Cover																		
<u>Woody Vine Stratum (Plot size: 3 foot radius)</u>																				
1. _____	_____	_____	_____																	
2. _____	_____	_____	_____																	
50% = _____, 20% = _____	0	= Total Cover																		
% Bare Ground in Herb Stratum <u>0</u>																				

Remarks: 100% dominant wetland vegetation per the Dominance Test

SOIL

Profile Description: (Describe to the depth needed to document the indicator or confirm the absence of indicators.)								
Depth (inches)	Matrix		Redox Features				Texture	Remarks
	Color (moist)	%	Color (moist)	%	Type ¹	Loc ²		
<u>0 to 2</u>	<u>Duff</u>	<u>100</u>	<u>None</u>	<u>None</u>	<u>None</u>	<u>None</u>	<u>Duff</u>	<u>w/leaf litter</u>
<u>2 to 18+</u>	<u>10YR 3/1</u>	<u>100</u>	<u>None</u>	<u>None</u>	<u>None</u>	<u>None</u>	<u>Silt loam</u>	_____
_____	_____	_____	_____	_____	_____	_____	_____	_____
_____	_____	_____	_____	_____	_____	_____	_____	_____
_____	_____	_____	_____	_____	_____	_____	_____	_____
_____	_____	_____	_____	_____	_____	_____	_____	_____
¹ Type: C= Concentration, D=Depletion, RM=Reduced Matrix, CS=Covered or Coated Sand Grains. ² Location: PL=Pore Lining, M=Matrix								
Hydric Soil Indicators: (Applicable to all LRRs, unless otherwise noted.)						Indicators for Problematic Hydric Soils³:		
<input type="checkbox"/> Histosol (A1)			<input type="checkbox"/> Sandy Redox (S5)			<input type="checkbox"/> 2 cm Muck (A10)		
<input type="checkbox"/> Histic Epipedon (A2)			<input type="checkbox"/> Stripped Matrix (S6)			<input type="checkbox"/> Red Parent Material (TF2)		
<input type="checkbox"/> Black Histic (A3)			<input type="checkbox"/> Loamy Mucky Mineral (F1) (except MLRA 1)			<input type="checkbox"/> Very Shallow Dark Surface (TF12)		
<input type="checkbox"/> Hydrogen Sulfide (A4)			<input type="checkbox"/> Loamy Gleyed Matrix (F2)			<input type="checkbox"/> Other (Explain in Remarks)		
<input type="checkbox"/> Depleted Below Dark Surface (A11)			<input type="checkbox"/> Depleted Matrix (F3)			³ Indicators of hydrophytic vegetation and wetland hydrology must be present, unless disturbed or problematic.		
<input checked="" type="checkbox"/> Thick Dark Surface (A12)			<input type="checkbox"/> Redox Dark Surface (F6)					
<input type="checkbox"/> Sandy Mucky Mineral (S1)			<input type="checkbox"/> Depleted Dark Surface (F7)					
<input type="checkbox"/> Sandy Gleyed Matrix (S4)			<input type="checkbox"/> Redox Depressions (F8)					
Restrictive Layer (if present):					Hydric Soils Present?			
Type: _____					Yes <input checked="" type="checkbox"/> No <input type="checkbox"/>			
Depth (inches): _____								
Remarks: 1 chroma								

HYDROLOGY

Wetland Hydrology Indicators:			
Primary Indicators (minimum of one required; check all that apply)		Secondary Indicators (2 or more required)	
<input checked="" type="checkbox"/> Surface Water (A1)	<input checked="" type="checkbox"/> Water-Stained Leaves (B9)	<input type="checkbox"/> Water-Stained Leaves (B9)	
<input checked="" type="checkbox"/> High Water Table (A2)	(except MLRA 1, 2, 4A, and 4B)	(MLRA 1, 2, 4A, and 4B)	
<input checked="" type="checkbox"/> Saturation (A3)	<input type="checkbox"/> Salt Crust (B11)	<input type="checkbox"/> Drainage Patterns (B10)	
<input checked="" type="checkbox"/> Water Marks (B1)	<input type="checkbox"/> Aquatic Invertebrates (B13)	<input type="checkbox"/> Dry-Season Water Table (C2)	
<input type="checkbox"/> Sediment Deposits (B2)	<input type="checkbox"/> Hydrogen Sulfide Odor (C1)	<input type="checkbox"/> Saturation Visible on Aerial Imagery (C9)	
<input type="checkbox"/> Drift Deposits (B3)	<input type="checkbox"/> Oxidized Rhizospheres along Living Roots (C3)	<input type="checkbox"/> Geomorphic Position (D2)	
<input type="checkbox"/> Algal Mat or Crust (B4)	<input type="checkbox"/> Presence of Reduced Iron (C4)	<input type="checkbox"/> Shallow Aquitard (D3)	
<input type="checkbox"/> Iron Deposits (B5)	<input type="checkbox"/> Recent Iron Reduction in Tilled Soils (C6)	<input type="checkbox"/> FAC-Neutral Test (D5)	
<input type="checkbox"/> Surface Soil Cracks (B6)	<input type="checkbox"/> Stunted or Stresses Plants (D1) (LRR A)	<input type="checkbox"/> Raised Ant Mounds (D6) (LRR A)	
<input type="checkbox"/> Inundation Visible on Aerial Imagery (B7)	<input type="checkbox"/> Other (Explain in Remarks)	<input type="checkbox"/> Frost-Heave Hummocks (D7)	
<input type="checkbox"/> Sparsely Vegetated Concave Surface (B8)			
Field Observations:		Wetland Hydrology Present?	
Surface Water Present?	Yes <input checked="" type="checkbox"/> No <input type="checkbox"/>	Yes <input checked="" type="checkbox"/> No <input type="checkbox"/>	
Water Table Present?	Yes <input checked="" type="checkbox"/> No <input type="checkbox"/>		
Saturation Present? (includes capillary fringe)	Yes <input checked="" type="checkbox"/> No <input type="checkbox"/>		
Depth (inches): <u>4 inches</u>			
Depth (inches): <u>Surface</u>			
Depth (inches): <u>Surface</u>			
Describe Recorded Data (stream gauge, monitoring well, aerial photos, previous inspections), if available:			
Remarks: Surface water 5 inches deep in wetland			

WETLAND DETERMINATION DATA FORM – Western Mountains, Valleys, and Coast Region

Project Site: Sound Transit East Link Extension Project City/County: Bellevue/King Sampling Date: Feb. 28, 2013
 Applicant/Owner: Sound Transit State: WA Sampling Point: SR 520 West SP2U
 Investigator(s): C Douglas & J. Pursley Section, Township, Range: S28, T24N, R5E
 Landform (hillslope, terrace, etc.): Narrow area between development Local relief (concave, convex, none): concave Slope (%): 0% to 2%
 Subregion (LRR): A Lat: 47.62N Long: 122.15W Datum: _____
 Soil Map Unit Name: Bellingham silt loam & Shalcar muck NWI classification: None Mapped
 Are climatic / hydrologic conditions on the site typical for this time of year? Yes No (If no, explain in Remarks.)
 Are Vegetation , Soil , or Hydrology , significantly disturbed? Are "Normal Circumstances" present? Yes No
 Are Vegetation , Soil , or Hydrology , naturally problematic? (If needed, explain any answers in Remarks.)

SUMMARY OF FINDINGS – Attach site map showing sampling point locations, transects, important features, etc.

Hydrophytic Vegetation Present?	Yes <input type="checkbox"/>	No <input checked="" type="checkbox"/>	Is the Sampled Area within a Wetland?	Yes <input type="checkbox"/>	No <input checked="" type="checkbox"/>
Hydric Soil Present?	Yes <input type="checkbox"/>	No <input checked="" type="checkbox"/>		Yes <input type="checkbox"/>	No <input checked="" type="checkbox"/>
Wetland Hydrology Present?	Yes <input type="checkbox"/>	No <input checked="" type="checkbox"/>		Yes <input type="checkbox"/>	No <input checked="" type="checkbox"/>
Remarks: Wetland is located in narrow area between commercial development and the SR 520 ROW fill prism. Wetland is a narrow depression with culverts at both ends. Wetland includes depressional and slope HGM classes.					

VEGETATION – Use scientific names of plants

Tree Stratum (Plot size: 30 foot radius)	Absolute % Cover	Dominant Species?	Indicator Status	Dominance Test Worksheet:																
1. <u><i>Pseudotsuga menziesii</i></u>	<u>95</u>	<u>yes</u>	<u>FACU</u>	Number of Dominant Species That Are OBL, FACW, or FAC: <u>1</u> (A) Total Number of Dominant Species Across All Strata: <u>3</u> (B) Percent of Dominant Species That Are OBL, FACW, or FAC: <u>34</u> (A/B)																
2. _____	_____	_____	_____																	
3. _____	_____	_____	_____																	
4. _____	_____	_____	_____																	
50% = <u>1</u> , 20% = <u>0</u>	<u>95</u>	= Total Cover																		
<u>Sapling/Shrub Stratum (Plot size: 15 foot radius)</u>																				
1. <u><i>Rubus armeniacus</i></u>	<u>10</u>	<u>yes</u>	<u>FACU</u>	Prevalence Index worksheet: <table style="width: 100%; border: none;"> <tr> <td style="text-align: right;"><u>Total % Cover of:</u></td> <td style="text-align: right;"><u>Multiply by:</u></td> </tr> <tr> <td>OBL species _____</td> <td>x1 = _____</td> </tr> <tr> <td>FACW species _____</td> <td>x2 = _____</td> </tr> <tr> <td>FAC species _____</td> <td>x3 = _____</td> </tr> <tr> <td>FACU species _____</td> <td>x4 = _____</td> </tr> <tr> <td>UPL species _____</td> <td>x5 = _____</td> </tr> <tr> <td>Column Totals: _____ (A)</td> <td>_____ (B)</td> </tr> <tr> <td colspan="2" style="text-align: center;">Prevalence Index = B/A = _____</td> </tr> </table>	<u>Total % Cover of:</u>	<u>Multiply by:</u>	OBL species _____	x1 = _____	FACW species _____	x2 = _____	FAC species _____	x3 = _____	FACU species _____	x4 = _____	UPL species _____	x5 = _____	Column Totals: _____ (A)	_____ (B)	Prevalence Index = B/A = _____	
<u>Total % Cover of:</u>	<u>Multiply by:</u>																			
OBL species _____	x1 = _____																			
FACW species _____	x2 = _____																			
FAC species _____	x3 = _____																			
FACU species _____	x4 = _____																			
UPL species _____	x5 = _____																			
Column Totals: _____ (A)	_____ (B)																			
Prevalence Index = B/A = _____																				
2. _____	_____	_____	_____																	
3. _____	_____	_____	_____																	
4. _____	_____	_____	_____																	
5. _____	_____	_____	_____																	
50% = <u>1</u> , 20% = <u>0</u>	<u>10</u>	= Total Cover																		
<u>Herb Stratum (Plot size: 3 foot radius)</u>																				
1. <u><i>Equisetum arvense</i></u>	<u>60</u>	<u>yes</u>	<u>FAC</u>	Hydrophytic Vegetation Indicators: <input type="checkbox"/> 1 – Rapid Test for Hydrophytic Vegetation <input checked="" type="checkbox"/> 2 - Dominance Test is >50% <input type="checkbox"/> 3 - Prevalence Index is $\leq 3.0^1$ <input type="checkbox"/> 4 - Morphological Adaptations ¹ (Provide supporting data in Remarks or on a separate sheet) <input type="checkbox"/> 5 - Wetland Non-Vascular Plants ¹ <input type="checkbox"/> Problematic Hydrophytic Vegetation ¹ (Explain) ¹ Indicators of hydric soil and wetland hydrology must be present, unless disturbed or problematic.																
2. _____	_____	_____	_____																	
3. _____	_____	_____	_____																	
4. _____	_____	_____	_____																	
5. _____	_____	_____	_____																	
6. _____	_____	_____	_____																	
7. _____	_____	_____	_____																	
8. _____	_____	_____	_____																	
9. _____	_____	_____	_____																	
10. _____	_____	_____	_____																	
11. _____	_____	_____	_____																	
50% = <u>1</u> , 20% = <u>0</u>	<u>60</u>	= Total Cover																		
<u>Woody Vine Stratum (Plot size: 3 foot radius)</u>																				
1. _____	_____	_____	_____	Hydrophytic Vegetation Present?																
2. _____	_____	_____	_____		Yes <input type="checkbox"/> No <input checked="" type="checkbox"/>															
50% = _____, 20% = _____	<u>0</u>	= Total Cover																		
% Bare Ground in Herb Stratum <u>40</u>																				

Remarks: 34% dominant wetland vegetation per the Dominance Test.

SOIL

Profile Description: (Describe to the depth needed to document the indicator or confirm the absence of indicators.)								
Depth (inches)	Matrix		Redox Features				Texture	Remarks
	Color (moist)	%	Color (moist)	%	Type ¹	Loc ²		
0 to 8	10YR 3/3	100	None	None	None	None	Sandy loam	w/gravel
8 to 18+	10YR 4/3	100	None	None	None	None	Loamy sand	w/angular rock
_____	_____	_____	_____	_____	_____	_____	_____	_____
_____	_____	_____	_____	_____	_____	_____	_____	_____
_____	_____	_____	_____	_____	_____	_____	_____	_____
_____	_____	_____	_____	_____	_____	_____	_____	_____
_____	_____	_____	_____	_____	_____	_____	_____	_____

¹Type: C= Concentration, D=Depletion, RM=Reduced Matrix, CS=Covered or Coated Sand Grains. ²Location: PL=Pore Lining, M=Matrix

Hydric Soil Indicators: (Applicable to all LRRs, unless otherwise noted.)			Indicators for Problematic Hydric Soils ³ :		
<input type="checkbox"/>	Histosol (A1)	<input type="checkbox"/>	Sandy Redox (S5)	<input type="checkbox"/>	2 cm Muck (A10)
<input type="checkbox"/>	Histic Epipedon (A2)	<input type="checkbox"/>	Stripped Matrix (S6)	<input type="checkbox"/>	Red Parent Material (TF2)
<input type="checkbox"/>	Black Histic (A3)	<input type="checkbox"/>	Loamy Mucky Mineral (F1) (except MLRA 1)	<input type="checkbox"/>	Very Shallow Dark Surface (TF12)
<input type="checkbox"/>	Hydrogen Sulfide (A4)	<input type="checkbox"/>	Loamy Gleyed Matrix (F2)	<input type="checkbox"/>	Other (Explain in Remarks)
<input type="checkbox"/>	Depleted Below Dark Surface (A11)	<input type="checkbox"/>	Depleted Matrix (F3)		
<input type="checkbox"/>	Thick Dark Surface (A12)	<input type="checkbox"/>	Redox Dark Surface (F6)		
<input type="checkbox"/>	Sandy Mucky Mineral (S1)	<input type="checkbox"/>	Depleted Dark Surface (F7)		
<input type="checkbox"/>	Sandy Gleyed Matrix (S4)	<input type="checkbox"/>	Redox Depressions (F8)		

³Indicators of hydrophytic vegetation and wetland hydrology must be present, unless disturbed or problematic.

Restrictive Layer (if present): Type: _____ Depth (inches): _____	Hydric Soils Present? Yes <input type="checkbox"/> No <input checked="" type="checkbox"/>
--	--

Remarks: 3 chroma

HYDROLOGY

Wetland Hydrology Indicators:	
Primary Indicators (minimum of one required; check all that apply)	Secondary Indicators (2 or more required)
<input type="checkbox"/> Surface Water (A1)	<input type="checkbox"/> Water-Stained Leaves (B9)
<input type="checkbox"/> High Water Table (A2)	(except MLRA 1, 2, 4A, and 4B)
<input type="checkbox"/> Saturation (A3)	<input type="checkbox"/> Salt Crust (B11)
<input type="checkbox"/> Water Marks (B1)	<input type="checkbox"/> Aquatic Invertebrates (B13)
<input type="checkbox"/> Sediment Deposits (B2)	<input type="checkbox"/> Hydrogen Sulfide Odor (C1)
<input type="checkbox"/> Drift Deposits (B3)	<input type="checkbox"/> Oxidized Rhizospheres along Living Roots (C3)
<input type="checkbox"/> Algal Mat or Crust (B4)	<input type="checkbox"/> Presence of Reduced Iron (C4)
<input type="checkbox"/> Iron Deposits (B5)	<input type="checkbox"/> Recent Iron Reduction in Tilled Soils (C6)
<input type="checkbox"/> Surface Soil Cracks (B6)	<input type="checkbox"/> Stunted or Stresses Plants (D1) (LRR A)
<input type="checkbox"/> Inundation Visible on Aerial Imagery (B7)	<input type="checkbox"/> Other (Explain in Remarks)
<input type="checkbox"/> Sparsely Vegetated Concave Surface (B8)	<input type="checkbox"/> Water-Stained Leaves (B9)
	(MLRA 1, 2, 4A, and 4B)
	<input type="checkbox"/> Drainage Patterns (B10)
	<input type="checkbox"/> Dry-Season Water Table (C2)
	<input type="checkbox"/> Saturation Visible on Aerial Imagery (C9)
	<input type="checkbox"/> Geomorphic Position (D2)
	<input type="checkbox"/> Shallow Aquitard (D3)
	<input type="checkbox"/> FAC-Neutral Test (D5)
	<input type="checkbox"/> Raised Ant Mounds (D6) (LRR A)
	<input type="checkbox"/> Frost-Heave Hummocks (D7)

Field Observations: Surface Water Present? Yes <input type="checkbox"/> No <input checked="" type="checkbox"/> Depth (inches): _____ Water Table Present? Yes <input type="checkbox"/> No <input checked="" type="checkbox"/> Depth (inches): _____ Saturation Present? (includes capillary fringe) Yes <input type="checkbox"/> No <input checked="" type="checkbox"/> Depth (inches): _____	Wetland Hydrology Present? Yes <input type="checkbox"/> No <input checked="" type="checkbox"/>
--	---

Describe Recorded Data (stream gauge, monitoring well, aerial photos, previous inspections), if available:

Remarks: No saturation or water table observed in sample plot

WETLAND DETERMINATION DATA FORM – Western Mountains, Valleys, and Coast Region

Project Site: Sound Transit East Link Extension Project City/County: Bellevue/King Sampling Date: Feb. 28, 2013
 Applicant/Owner: Sound Transit State: WA Sampling Point: SR 520 West SP3W
 Investigator(s): C Douglas & J. Pursley Section, Township, Range: S28, T24N, R5E
 Landform (hillslope, terrace, etc.): Narrow area between development Local relief (concave, convex, none): concave Slope (%): 0% to 2%
 Subregion (LRR): A Lat: 47.62N Long: 122.15W Datum: _____
 Soil Map Unit Name: Bellingham silt loam & Shalcar muck NWI classification: None Mapped
 Are climatic / hydrologic conditions on the site typical for this time of year? Yes No (If no, explain in Remarks.)
 Are Vegetation , Soil , or Hydrology , significantly disturbed? Are "Normal Circumstances" present? Yes No
 Are Vegetation , Soil , or Hydrology , naturally problematic? (If needed, explain any answers in Remarks.)

SUMMARY OF FINDINGS – Attach site map showing sampling point locations, transects, important features, etc.

Hydrophytic Vegetation Present?	Yes <input checked="" type="checkbox"/>	No <input type="checkbox"/>	Is the Sampled Area within a Wetland?	Yes <input checked="" type="checkbox"/>	No <input type="checkbox"/>
Hydric Soil Present?	Yes <input checked="" type="checkbox"/>	No <input type="checkbox"/>		Yes <input checked="" type="checkbox"/>	No <input type="checkbox"/>
Wetland Hydrology Present?	Yes <input checked="" type="checkbox"/>	No <input type="checkbox"/>		Yes <input checked="" type="checkbox"/>	No <input type="checkbox"/>
Remarks: Wetland is located in narrow area between commercial development and the SR 520 ROW fill prism. Wetland is a narrow depression with culverts at both ends. Wetland includes depressionnal and slope HGM classes.					

VEGETATION – Use scientific names of plants

Tree Stratum (Plot size: 30 foot radius)	Absolute % Cover	Dominant Species?	Indicator Status	Dominance Test Worksheet:
1. <u><i>Alnus rubra</i></u>	<u>90</u>	<u>yes</u>	<u>FACW</u>	Number of Dominant Species That Are OBL, FACW, or FAC: <u>4</u> (A) Total Number of Dominant Species Across All Strata: <u>4</u> (B) Percent of Dominant Species That Are OBL, FACW, or FAC: <u>100</u> (A/B)
2. <u><i>Salix lasiandra</i></u>	<u>15</u>	<u>no</u>	<u>FACW</u>	
3. _____	_____	_____	_____	
4. _____	_____	_____	_____	
50% = <u>1</u> , 20% = <u>0</u>	<u>100</u>	= Total Cover		
Sapling/Shrub Stratum (Plot size: 15 foot radius)	Absolute % Cover	Dominant Species?	Indicator Status	Prevalence Index worksheet:
1. <u><i>Cornus sericea</i></u>	<u>40</u>	<u>yes</u>	<u>FACW</u>	Total % Cover of: _____ Multiply by: _____ OBL species _____ x1 = _____ FACW species _____ x2 = _____ FAC species _____ x3 = _____ FACU species _____ x4 = _____ UPL species _____ x5 = _____ Column Totals: _____ (A) _____ (B) Prevalence Index = B/A = _____
2. <u><i>Rubus armeniacus</i></u>	<u>10</u>	<u>no</u>	<u>FACU</u>	
3. _____	_____	_____	_____	
4. _____	_____	_____	_____	
5. _____	_____	_____	_____	
50% = <u>1</u> , 20% = <u>0</u>	<u>50</u>	= Total Cover		
Herb Stratum (Plot size: 3 foot radius)	Absolute % Cover	Dominant Species?	Indicator Status	Hydrophytic Vegetation Indicators:
1. <u><i>Equisetum arvense</i></u>	<u>5</u>	<u>no</u>	<u>FAC</u>	<input type="checkbox"/> 1 – Rapid Test for Hydrophytic Vegetation <input checked="" type="checkbox"/> 2 - Dominance Test is >50% <input type="checkbox"/> 3 - Prevalence Index is ≤3.0 ¹ <input type="checkbox"/> 4 - Morphological Adaptations ¹ (Provide supporting data in Remarks or on a separate sheet) <input type="checkbox"/> 5 - Wetland Non-Vascular Plants ¹ <input type="checkbox"/> Problematic Hydrophytic Vegetation ¹ (Explain) ¹ Indicators of hydric soil and wetland hydrology must be present, unless disturbed or problematic.
2. <u><i>Lysichiton americanus</i></u>	<u>20</u>	<u>yes</u>	<u>OBL</u>	
3. <u><i>Oenanthe sarmentosa</i></u>	<u>5</u>	<u>no</u>	<u>OBL</u>	
4. _____	_____	_____	_____	
5. _____	_____	_____	_____	
6. _____	_____	_____	_____	
7. _____	_____	_____	_____	
8. _____	_____	_____	_____	
9. _____	_____	_____	_____	
10. _____	_____	_____	_____	
11. _____	_____	_____	_____	
50% = <u>1</u> , 20% = <u>0</u>	<u>30</u>	= Total Cover		
Woody Vine Stratum (Plot size: 3 foot radius)	Absolute % Cover	Dominant Species?	Indicator Status	Hydrophytic Vegetation Present?
1. _____	_____	_____	_____	Yes <input checked="" type="checkbox"/> No <input type="checkbox"/>
2. _____	_____	_____	_____	
50% = _____, 20% = _____	<u>0</u>	= Total Cover		
% Bare Ground in Herb Stratum <u>70</u>				

Remarks: 100% dominant wetland vegetation per the Dominance Test

SOIL

Profile Description: (Describe to the depth needed to document the indicator or confirm the absence of indicators.)								
Depth (inches)	Matrix		Redox Features				Texture	Remarks
	Color (moist)	%	Color (moist)	%	Type ¹	Loc ²		
<u>0 to 18+</u>	<u>10YR 3/1</u>	<u>100</u>	<u>None</u>	<u>None</u>	<u>None</u>	<u>None</u>	<u>Sandy loam</u>	<u>w/gravel</u>
¹ Type: C= Concentration, D=Depletion, RM=Reduced Matrix, CS=Covered or Coated Sand Grains.					² Location: PL=Pore Lining, M=Matrix			
Hydric Soil Indicators: (Applicable to all LRRs, unless otherwise noted.)						Indicators for Problematic Hydric Soils³:		
<input type="checkbox"/> Histosol (A1)			<input type="checkbox"/> Sandy Redox (S5)			<input type="checkbox"/> 2 cm Muck (A10)		
<input type="checkbox"/> Histic Epipedon (A2)			<input type="checkbox"/> Stripped Matrix (S6)			<input type="checkbox"/> Red Parent Material (TF2)		
<input type="checkbox"/> Black Histic (A3)			<input type="checkbox"/> Loamy Mucky Mineral (F1) (except MLRA 1)			<input type="checkbox"/> Very Shallow Dark Surface (TF12)		
<input type="checkbox"/> Hydrogen Sulfide (A4)			<input type="checkbox"/> Loamy Gleyed Matrix (F2)			<input type="checkbox"/> Other (Explain in Remarks)		
<input type="checkbox"/> Depleted Below Dark Surface (A11)			<input type="checkbox"/> Depleted Matrix (F3)			³ Indicators of hydrophytic vegetation and wetland hydrology must be present, unless disturbed or problematic.		
<input checked="" type="checkbox"/> Thick Dark Surface (A12)			<input type="checkbox"/> Redox Dark Surface (F6)					
<input type="checkbox"/> Sandy Mucky Mineral (S1)			<input type="checkbox"/> Depleted Dark Surface (F7)					
<input type="checkbox"/> Sandy Gleyed Matrix (S4)			<input type="checkbox"/> Redox Depressions (F8)					
Restrictive Layer (if present):					Hydric Soils Present?			
Type: _____					Yes <input checked="" type="checkbox"/> No <input type="checkbox"/>			
Depth (inches): _____								
Remarks: 1 chroma								

HYDROLOGY

Wetland Hydrology Indicators:			
Primary Indicators (minimum of one required; check all that apply)		Secondary Indicators (2 or more required)	
<input checked="" type="checkbox"/> Surface Water (A1)	<input checked="" type="checkbox"/> Water-Stained Leaves (B9)	<input type="checkbox"/> Water-Stained Leaves (B9)	
<input checked="" type="checkbox"/> High Water Table (A2)	(except MLRA 1, 2, 4A, and 4B)	(MLRA 1, 2, 4A, and 4B)	
<input checked="" type="checkbox"/> Saturation (A3)	<input type="checkbox"/> Salt Crust (B11)	<input type="checkbox"/> Drainage Patterns (B10)	
<input checked="" type="checkbox"/> Water Marks (B1)	<input type="checkbox"/> Aquatic Invertebrates (B13)	<input type="checkbox"/> Dry-Season Water Table (C2)	
<input type="checkbox"/> Sediment Deposits (B2)	<input type="checkbox"/> Hydrogen Sulfide Odor (C1)	<input type="checkbox"/> Saturation Visible on Aerial Imagery (C9)	
<input type="checkbox"/> Drift Deposits (B3)	<input type="checkbox"/> Oxidized Rhizospheres along Living Roots (C3)	<input type="checkbox"/> Geomorphic Position (D2)	
<input type="checkbox"/> Algal Mat or Crust (B4)	<input type="checkbox"/> Presence of Reduced Iron (C4)	<input type="checkbox"/> Shallow Aquitard (D3)	
<input type="checkbox"/> Iron Deposits (B5)	<input type="checkbox"/> Recent Iron Reduction in Tilled Soils (C6)	<input type="checkbox"/> FAC-Neutral Test (D5)	
<input type="checkbox"/> Surface Soil Cracks (B6)	<input type="checkbox"/> Stunted or Stresses Plants (D1) (LRR A)	<input type="checkbox"/> Raised Ant Mounds (D6) (LRR A)	
<input type="checkbox"/> Inundation Visible on Aerial Imagery (B7)	<input type="checkbox"/> Other (Explain in Remarks)	<input type="checkbox"/> Frost-Heave Hummocks (D7)	
<input type="checkbox"/> Sparsely Vegetated Concave Surface (B8)			
Field Observations:		Wetland Hydrology Present?	
Surface Water Present?	Yes <input checked="" type="checkbox"/> No <input type="checkbox"/>	Yes <input checked="" type="checkbox"/> No <input type="checkbox"/>	
Water Table Present?	Yes <input checked="" type="checkbox"/> No <input type="checkbox"/>		
Saturation Present? (includes capillary fringe)	Yes <input checked="" type="checkbox"/> No <input type="checkbox"/>	Depth (inches): <u>2 inches</u>	
	Depth (inches): <u>Surface</u>	Depth (inches): <u>Surface</u>	
Describe Recorded Data (stream gauge, monitoring well, aerial photos, previous inspections), if available:			
Remarks: Surface water 2 inches deep in wetland			

WETLAND DETERMINATION DATA FORM – Western Mountains, Valleys, and Coast Region

Project Site: Sound Transit East Link Extension Project City/County: Bellevue/King Sampling Date: Feb. 28, 2013
 Applicant/Owner: Sound Transit State: WA Sampling Point: SR 520 West SP4U
 Investigator(s): C Douglas & J. Pursley Section, Township, Range: S28, T24N, R5E
 Landform (hillslope, terrace, etc.): Narrow area between development Local relief (concave, convex, none): concave Slope (%): 0% to 2%
 Subregion (LRR): A Lat: 47.62N Long: 122.15W Datum: _____
 Soil Map Unit Name: Bellingham silt loam & Shalcar muck NWI classification: None Mapped
 Are climatic / hydrologic conditions on the site typical for this time of year? Yes No (If no, explain in Remarks.)
 Are Vegetation , Soil , or Hydrology , significantly disturbed? Are "Normal Circumstances" present? Yes No
 Are Vegetation , Soil , or Hydrology , naturally problematic? (If needed, explain any answers in Remarks.)

SUMMARY OF FINDINGS – Attach site map showing sampling point locations, transects, important features, etc.

Hydrophytic Vegetation Present?	Yes <input type="checkbox"/>	No <input checked="" type="checkbox"/>	Is the Sampled Area within a Wetland?	Yes <input type="checkbox"/>	No <input checked="" type="checkbox"/>
Hydric Soil Present?	Yes <input type="checkbox"/>	No <input checked="" type="checkbox"/>		Yes <input type="checkbox"/>	No <input checked="" type="checkbox"/>
Wetland Hydrology Present?	Yes <input type="checkbox"/>	No <input checked="" type="checkbox"/>		Yes <input type="checkbox"/>	No <input checked="" type="checkbox"/>
Remarks: Wetland is located in narrow area between commercial development and the SR 520 ROW fill prism. Wetland is a narrow depression with culverts at both ends. Wetland includes depression and slope HGM classes.					

VEGETATION – Use scientific names of plants

Tree Stratum (Plot size: 30 foot radius)	Absolute % Cover	Dominant Species?	Indicator Status	Dominance Test Worksheet:
1. <u><i>Alnus rubra</i></u>	<u>25</u>	<u>yes</u>	<u>FAC</u>	Number of Dominant Species That Are OBL, FACW, or FAC: <u>2</u> (A) Total Number of Dominant Species Across All Strata: <u>5</u> (B) Percent of Dominant Species That Are OBL, FACW, or FAC: <u>40</u> (A/B)
2. <u><i>Populus trichocarpa</i></u>	<u>70</u>	<u>yes</u>	<u>FAC</u>	
3. _____	_____	_____	_____	
4. _____	_____	_____	_____	
50% = <u>1</u> , 20% = <u>1</u>	<u>95</u>	= Total Cover		
Sapling/Shrub Stratum (Plot size: 15 foot radius)				Prevalence Index worksheet: Total % Cover of: _____ Multiply by: OBL species _____ x1 = _____ FACW species _____ x2 = _____ FAC species _____ x3 = _____ FACU species _____ x4 = _____ UPL species _____ x5 = _____ Column Totals: _____ (A) _____ (B) Prevalence Index = B/A = _____
1. <u><i>Cytisus scoparius</i></u>	<u>10</u>	<u>yes</u>	<u>FACU</u>	
2. <u><i>Ilex aquifolium</i></u>	<u>15</u>	<u>yes</u>	<u>FACU</u>	
3. <u><i>Rubus armeniacus</i></u>	<u>50</u>	<u>yes</u>	<u>FACU</u>	
4. <u><i>Symphoricarpos albus</i></u>	<u>5</u>	<u>no</u>	<u>FACU</u>	
5. _____	_____	_____	_____	
50% = <u>2</u> , 20% = <u>1</u>	<u>80</u>	= Total Cover		
Herb Stratum (Plot size: 3 foot radius)				Hydrophytic Vegetation Indicators: <input type="checkbox"/> 1 – Rapid Test for Hydrophytic Vegetation <input checked="" type="checkbox"/> 2 - Dominance Test is >50% <input type="checkbox"/> 3 - Prevalence Index is ≤3.0 ¹ <input type="checkbox"/> 4 - Morphological Adaptations ¹ (Provide supporting data in Remarks or on a separate sheet) <input type="checkbox"/> 5 - Wetland Non-Vascular Plants ¹ <input type="checkbox"/> Problematic Hydrophytic Vegetation ¹ (Explain) ¹ Indicators of hydric soil and wetland hydrology must be present, unless disturbed or problematic.
1. <u><i>Polystichum munitum</i></u>	<u>10</u>	<u>yes</u>	<u>FACU</u>	
2. _____	_____	_____	_____	
3. _____	_____	_____	_____	
4. _____	_____	_____	_____	
5. _____	_____	_____	_____	
6. _____	_____	_____	_____	
7. _____	_____	_____	_____	
8. _____	_____	_____	_____	
9. _____	_____	_____	_____	
10. _____	_____	_____	_____	
11. _____	_____	_____	_____	
50% = <u>1</u> , 20% = <u>0</u>	<u>10</u>	= Total Cover		
Woody Vine Stratum (Plot size: 3 foot radius)				Hydrophytic Vegetation Present? Yes <input type="checkbox"/> No <input checked="" type="checkbox"/>
1. <u><i>Hedera hibernica</i></u>	<u>25</u>	<u>yes</u>	<u>UPL</u>	
2. _____	_____	_____	_____	
50% = <u>1</u> , 20% = _____	<u>0</u>	= Total Cover		
% Bare Ground in Herb Stratum <u>65</u>				

Remarks: 40% dominant wetland vegetation per the Dominance Test.

SOIL

Profile Description: (Describe to the depth needed to document the indicator or confirm the absence of indicators.)

Depth (inches)	Matrix		Redox Features				Texture	Remarks
	Color (moist)	%	Color (moist)	%	Type ¹	Loc ²		
0 to 7	10YR 3/3	100	None	None	None	None	Sandy loam	w/gravel
7 to 18+	10YR 4/3	100	None	None	None	None	Sandy loam	w/cobble
_____	_____	_____	_____	_____	_____	_____	_____	_____
_____	_____	_____	_____	_____	_____	_____	_____	_____
_____	_____	_____	_____	_____	_____	_____	_____	_____
_____	_____	_____	_____	_____	_____	_____	_____	_____
_____	_____	_____	_____	_____	_____	_____	_____	_____

¹Type: C= Concentration, D=Depletion, RM=Reduced Matrix, CS=Covered or Coated Sand Grains. ²Location: PL=Pore Lining, M=Matrix

Hydric Soil Indicators: (Applicable to all LRRs, unless otherwise noted.)

- Histosol (A1)
- Histic Epipedon (A2)
- Black Histic (A3)
- Hydrogen Sulfide (A4)
- Depleted Below Dark Surface (A11)
- Thick Dark Surface (A12)
- Sandy Mucky Mineral (S1)
- Sandy Gleyed Matrix (S4)
- Sandy Redox (S5)
- Stripped Matrix (S6)
- Loamy Mucky Mineral (F1) **(except MLRA 1)**
- Loamy Gleyed Matrix (F2)
- Depleted Matrix (F3)
- Redox Dark Surface (F6)
- Depleted Dark Surface (F7)
- Redox Depressions (F8)

Indicators for Problematic Hydric Soils³:

- 2 cm Muck (A10)
- Red Parent Material (TF2)
- Very Shallow Dark Surface (TF12)
- Other (Explain in Remarks)

³Indicators of hydrophytic vegetation and wetland hydrology must be present, unless disturbed or problematic.

Restrictive Layer (if present):

Type: _____
 Depth (inches): _____

Hydric Soils Present? Yes No

Remarks: 3 chroma

HYDROLOGY

Wetland Hydrology Indicators:

Primary Indicators (minimum of one required; check all that apply)

- Surface Water (A1)
- High Water Table (A2)
- Saturation (A3)
- Water Marks (B1)
- Sediment Deposits (B2)
- Drift Deposits (B3)
- Algal Mat or Crust (B4)
- Iron Deposits (B5)
- Surface Soil Cracks (B6)
- Inundation Visible on Aerial Imagery (B7)
- Sparsely Vegetated Concave Surface (B8)
- Water-Stained Leaves (B9) **(except MLRA 1, 2, 4A, and 4B)**
- Salt Crust (B11)
- Aquatic Invertebrates (B13)
- Hydrogen Sulfide Odor (C1)
- Oxidized Rhizospheres along Living Roots (C3)
- Presence of Reduced Iron (C4)
- Recent Iron Reduction in Tilled Soils (C6)
- Stunted or Stresses Plants (D1) **(LRR A)**
- Other (Explain in Remarks)

Secondary Indicators (2 or more required)

- Water-Stained Leaves (B9) **(MLRA 1, 2, 4A, and 4B)**
- Drainage Patterns (B10)
- Dry-Season Water Table (C2)
- Saturation Visible on Aerial Imagery (C9)
- Geomorphic Position (D2)
- Shallow Aquitard (D3)
- FAC-Neutral Test (D5)
- Raised Ant Mounds (D6) **(LRR A)**
- Frost-Heave Hummocks (D7)

Field Observations:

Surface Water Present? Yes No Depth (inches): _____
 Water Table Present? Yes No Depth (inches): _____
 Saturation Present? (includes capillary fringe) Yes No Depth (inches): _____

Wetland Hydrology Present? Yes No

Describe Recorded Data (stream gauge, monitoring well, aerial photos, previous inspections), if available:

Remarks: No saturation or water table observed in sample plot

WETLAND DETERMINATION DATA FORM – Western Mountains, Valleys, and Coast Region

Project Site: Sound Transit East Link Extension Project City/County: Bellevue/King Sampling Date: Nov. 26, 2013
 Applicant/Owner: Sound Transit State: WA Sampling Point: Suspect Area SP1-U
 Investigator(s): C Douglas Section, Township, Range: S29, T24N, R5E
 Landform (hillslope, terrace, etc.): Narrow area between development Local relief (concave, convex, none): concave Slope (%): 0% to 2%
 Subregion (LRR): A Lat: 47.62N Long: 122.18W Datum: _____
 Soil Map Unit Name: Kitsap silt loam NWI classification: None Mapped
 Are climatic / hydrologic conditions on the site typical for this time of year? Yes No (If no, explain in Remarks.)
 Are Vegetation , Soil , or Hydrology , significantly disturbed? Are "Normal Circumstances" present? Yes No
 Are Vegetation , Soil , or Hydrology , naturally problematic? (If needed, explain any answers in Remarks.)

SUMMARY OF FINDINGS – Attach site map showing sampling point locations, transects, important features, etc.

Hydrophytic Vegetation Present?	Yes <input checked="" type="checkbox"/>	No <input type="checkbox"/>	Is the Sampled Area within a Wetland?	Yes <input type="checkbox"/>	No <input checked="" type="checkbox"/>
Hydric Soil Present?	Yes <input type="checkbox"/>	No <input checked="" type="checkbox"/>		Yes <input type="checkbox"/>	No <input checked="" type="checkbox"/>
Wetland Hydrology Present?	Yes <input type="checkbox"/>	No <input checked="" type="checkbox"/>		Yes <input type="checkbox"/>	No <input checked="" type="checkbox"/>
Remarks: Sample plot established in suspect area at the request of Sound Transit (Marti L.) to confirm wetland conditions were not present. Suspect area located in depression on the west side of old BNSF railroad tracks, south of the South Lake Wetland. Development is located to the west. Fill prism located on both sides of depression and substrate within depression contains compacted fill conditions..					

VEGETATION – Use scientific names of plants

Tree Stratum (Plot size: 30 foot radius)	Absolute % Cover	Dominant Species?	Indicator Status	Dominance Test Worksheet:																
1. _____	_____	_____	_____	Number of Dominant Species That Are OBL, FACW, or FAC: <u>3</u> (A) Total Number of Dominant Species Across All Strata: <u>5</u> (B) Percent of Dominant Species That Are OBL, FACW, or FAC: <u>60</u> (A/B)																
2. _____	_____	_____	_____																	
3. _____	_____	_____	_____																	
4. _____	_____	_____	_____																	
50% = <u>0</u> , 20% = <u>0</u>	<u>0</u>	= Total Cover		Prevalence Index worksheet: <table style="width: 100%; border: none;"> <tr> <td style="text-align: center;">Total % Cover of:</td> <td style="text-align: center;">Multiply by:</td> </tr> <tr> <td>OBL species _____</td> <td>x1 = _____</td> </tr> <tr> <td>FACW species _____</td> <td>x2 = _____</td> </tr> <tr> <td>FAC species _____</td> <td>x3 = _____</td> </tr> <tr> <td>FACU species _____</td> <td>x4 = _____</td> </tr> <tr> <td>UPL species _____</td> <td>x5 = _____</td> </tr> <tr> <td>Column Totals: _____ (A)</td> <td>_____ (B)</td> </tr> <tr> <td colspan="2" style="text-align: center;">Prevalence Index = B/A = _____</td> </tr> </table>	Total % Cover of:	Multiply by:	OBL species _____	x1 = _____	FACW species _____	x2 = _____	FAC species _____	x3 = _____	FACU species _____	x4 = _____	UPL species _____	x5 = _____	Column Totals: _____ (A)	_____ (B)	Prevalence Index = B/A = _____	
Total % Cover of:	Multiply by:																			
OBL species _____	x1 = _____																			
FACW species _____	x2 = _____																			
FAC species _____	x3 = _____																			
FACU species _____	x4 = _____																			
UPL species _____	x5 = _____																			
Column Totals: _____ (A)	_____ (B)																			
Prevalence Index = B/A = _____																				
Sapling/Shrub Stratum (Plot size: 15 foot radius)																				
1. <u>Cytisus scoparius</u>	<u>10</u>	<u>yes</u>	<u>UPL</u>																	
2. <u>Rubus armeniacus</u>	<u>15</u>	<u>yes</u>	<u>FACU</u>																	
3. _____	_____	_____	_____																	
4. _____	_____	_____	_____																	
5. _____	_____	_____	_____																	
50% = <u>1</u> , 20% = <u>1</u>	<u>25</u>	= Total Cover																		
Herb Stratum (Plot size: 3 foot radius)																				
1. <u>Agrostis capillaris</u>	<u>5</u>	<u>no</u>	<u>FAC</u>																	
2. <u>Equisetum arvense</u>	<u>15</u>	<u>yes</u>	<u>FAC</u>																	
3. <u>Juncus effusus</u>	<u>40</u>	<u>yes</u>	<u>FACW</u>																	
4. <u>Phalaris arundinacea</u>	<u>15</u>	<u>yes</u>	<u>FACW</u>																	
5. _____	_____	_____	_____																	
6. _____	_____	_____	_____																	
7. _____	_____	_____	_____																	
8. _____	_____	_____	_____																	
9. _____	_____	_____	_____																	
10. _____	_____	_____	_____																	
11. _____	_____	_____	_____																	
50% = <u>1</u> , 20% = <u>2</u>	<u>75</u>	= Total Cover																		
Woody Vine Stratum (Plot size: 3 foot radius)																				
1. _____	_____	_____	_____																	
2. _____	_____	_____	_____																	
50% = <u>0</u> , 20% = <u>0</u>	<u>0</u>	= Total Cover																		
% Bare Ground in Herb Stratum <u>25</u>																				
Hydrophytic Vegetation Indicators: <input type="checkbox"/> 1 – Rapid Test for Hydrophytic Vegetation <input checked="" type="checkbox"/> 2 - Dominance Test is >50% <input type="checkbox"/> 3 - Prevalence Index is ≤3.0 ¹ <input type="checkbox"/> 4 - Morphological Adaptations ¹ (Provide supporting data in Remarks or on a separate sheet) <input type="checkbox"/> 5 - Wetland Non-Vascular Plants ¹ <input type="checkbox"/> Problematic Hydrophytic Vegetation ¹ (Explain)																				
¹ Indicators of hydric soil and wetland hydrology must be present, unless disturbed or problematic.																				
Hydrophytic Vegetation Present? Yes <input checked="" type="checkbox"/> No <input type="checkbox"/>																				

Remarks: 60% dominant wetland vegetation per the Dominance Test.

SOIL

Profile Description: (Describe to the depth needed to document the indicator or confirm the absence of indicators.)								
Depth (inches)	Matrix		Redox Features				Texture	Remarks
	Color (moist)	%	Color (moist)	%	Type ¹	Loc ²		
0 to 7	10YR 3/3	98	10YR 4/2	2	D	M	Sandy loam	w/cobble & gravel & angular rock
7 to 18+	None	100	None	None	None	None	Compact fill	w/cobble & gravel
_____	_____	_____	_____	_____	_____	_____	_____	_____
_____	_____	_____	_____	_____	_____	_____	_____	_____
_____	_____	_____	_____	_____	_____	_____	_____	_____
_____	_____	_____	_____	_____	_____	_____	_____	_____
_____	_____	_____	_____	_____	_____	_____	_____	_____

¹Type: C= Concentration, D=Depletion, RM=Reduced Matrix, CS=Covered or Coated Sand Grains. ²Location: PL=Pore Lining, M=Matrix

Hydric Soil Indicators: (Applicable to all LRRs, unless otherwise noted.)				Indicators for Problematic Hydric Soils ³ :	
<input type="checkbox"/> Histosol (A1)	<input type="checkbox"/> Sandy Redox (S5)	<input type="checkbox"/> 2 cm Muck (A10)			
<input type="checkbox"/> Histic Epipedon (A2)	<input type="checkbox"/> Stripped Matrix (S6)	<input type="checkbox"/> Red Parent Material (TF2)			
<input type="checkbox"/> Black Histic (A3)	<input type="checkbox"/> Loamy Mucky Mineral (F1) (except MLRA 1)	<input type="checkbox"/> Very Shallow Dark Surface (TF12)			
<input type="checkbox"/> Hydrogen Sulfide (A4)	<input type="checkbox"/> Loamy Gleyed Matrix (F2)	<input type="checkbox"/> Other (Explain in Remarks)			
<input type="checkbox"/> Depleted Below Dark Surface (A11)	<input type="checkbox"/> Depleted Matrix (F3)				
<input type="checkbox"/> Thick Dark Surface (A12)	<input type="checkbox"/> Redox Dark Surface (F6)				
<input type="checkbox"/> Sandy Mucky Mineral (S1)	<input type="checkbox"/> Depleted Dark Surface (F7)	³ Indicators of hydrophytic vegetation and wetland hydrology must be present, unless disturbed or problematic.			
<input type="checkbox"/> Sandy Gleyed Matrix (S4)	<input type="checkbox"/> Redox Depressions (F8)				

Restrictive Layer (if present): Type: <u>Fill prism</u> Depth (inches): <u>7 inches</u>	Hydric Soils Present? Yes <input type="checkbox"/> No <input checked="" type="checkbox"/>
--	--

Remarks: 3 chroma with 2% redox features with gravel, cobble, and angular rock, compacted fill features

HYDROLOGY

Wetland Hydrology Indicators:			
Primary Indicators (minimum of one required; check all that apply)		Secondary Indicators (2 or more required)	
<input type="checkbox"/> Surface Water (A1)	<input type="checkbox"/> Water-Stained Leaves (B9)	<input type="checkbox"/> Water-Stained Leaves (B9)	
<input type="checkbox"/> High Water Table (A2)	(except MLRA 1, 2, 4A, and 4B)	(MLRA 1, 2, 4A, and 4B)	
<input type="checkbox"/> Saturation (A3)	<input type="checkbox"/> Salt Crust (B11)	<input type="checkbox"/> Drainage Patterns (B10)	
<input type="checkbox"/> Water Marks (B1)	<input type="checkbox"/> Aquatic Invertebrates (B13)	<input type="checkbox"/> Dry-Season Water Table (C2)	
<input type="checkbox"/> Sediment Deposits (B2)	<input type="checkbox"/> Hydrogen Sulfide Odor (C1)	<input type="checkbox"/> Saturation Visible on Aerial Imagery (C9)	
<input type="checkbox"/> Drift Deposits (B3)	<input type="checkbox"/> Oxidized Rhizospheres along Living Roots (C3)	<input type="checkbox"/> Geomorphic Position (D2)	
<input type="checkbox"/> Algal Mat or Crust (B4)	<input type="checkbox"/> Presence of Reduced Iron (C4)	<input type="checkbox"/> Shallow Aquitard (D3)	
<input type="checkbox"/> Iron Deposits (B5)	<input type="checkbox"/> Recent Iron Reduction in Tilled Soils (C6)	<input type="checkbox"/> FAC-Neutral Test (D5)	
<input type="checkbox"/> Surface Soil Cracks (B6)	<input type="checkbox"/> Stunted or Stresses Plants (D1) (LRR A)	<input type="checkbox"/> Raised Ant Mounds (D6) (LRR A)	
<input type="checkbox"/> Inundation Visible on Aerial Imagery (B7)	<input type="checkbox"/> Other (Explain in Remarks)	<input type="checkbox"/> Frost-Heave Hummocks (D7)	
<input type="checkbox"/> Sparsely Vegetated Concave Surface (B8)			

Field Observations: Surface Water Present? Yes <input type="checkbox"/> No <input checked="" type="checkbox"/> Depth (inches): _____ Water Table Present? Yes <input type="checkbox"/> No <input checked="" type="checkbox"/> Depth (inches): _____ Saturation Present? (includes capillary fringe) Yes <input type="checkbox"/> No <input checked="" type="checkbox"/> Depth (inches): _____	Wetland Hydrology Present? Yes <input type="checkbox"/> No <input checked="" type="checkbox"/>
---	---

Describe Recorded Data (stream gauge, monitoring well, aerial photos, previous inspections), if available:

Remarks: No saturation or water table observed in sample plot

WETLAND DETERMINATION DATA FORM – Western Mountains, Valleys, and Coast Region

Project Site: Sound Transit East Link Extension Project City/County: Bellevue/King Sampling Date: Nov. 26, 2013
 Applicant/Owner: Sound Transit State: WA Sampling Point: Suspect Area SP2-U
 Investigator(s): C Douglas Section, Township, Range: S29, T24N, R5E
 Landform (hillslope, terrace, etc.): Narrow area between development Local relief (concave, convex, none): concave Slope (%): 0% to 2%
 Subregion (LRR): A Lat: 47.62N Long: 122.18W Datum: _____
 Soil Map Unit Name: Kitsap silt loam NWI classification: None Mapped
 Are climatic / hydrologic conditions on the site typical for this time of year? Yes No (If no, explain in Remarks.)
 Are Vegetation , Soil , or Hydrology , significantly disturbed? Are "Normal Circumstances" present? Yes No
 Are Vegetation , Soil , or Hydrology , naturally problematic? (If needed, explain any answers in Remarks.)

SUMMARY OF FINDINGS – Attach site map showing sampling point locations, transects, important features, etc.

Hydrophytic Vegetation Present?	Yes <input checked="" type="checkbox"/>	No <input type="checkbox"/>	Is the Sampled Area within a Wetland?	Yes <input type="checkbox"/>	No <input checked="" type="checkbox"/>
Hydric Soil Present?	Yes <input type="checkbox"/>	No <input checked="" type="checkbox"/>		Yes <input type="checkbox"/>	No <input checked="" type="checkbox"/>
Wetland Hydrology Present?	Yes <input type="checkbox"/>	No <input checked="" type="checkbox"/>		Yes <input type="checkbox"/>	No <input checked="" type="checkbox"/>
Remarks: Sample plot established in suspect area at the request of Sound Transit (Marti L.) to confirm wetland conditions were not present. Suspect area located in a low-lying area on the east side of old BNSF railroad tracks, south of the BNSF East Wetland. Development is located to the east. Fill prism located on both sides of the low-lying area and substrate within this area contains compacted fill conditions..					

VEGETATION – Use scientific names of plants

Tree Stratum (Plot size: 30 foot radius)	Absolute % Cover	Dominant Species?	Indicator Status	Dominance Test Worksheet:
1. <u><i>Alnus rubra</i></u>	<u>15</u>	<u>yes</u>	<u>FAC</u>	Number of Dominant Species That Are OBL, FACW, or FAC: <u>3</u> (A) Total Number of Dominant Species Across All Strata: <u>5</u> (B) Percent of Dominant Species That Are OBL, FACW, or FAC: <u>60</u> (A/B)
2. _____	_____	_____	_____	
3. _____	_____	_____	_____	
4. _____	_____	_____	_____	
50% = <u>1</u> , 20% = <u>0</u>	<u>15</u>	= Total Cover		
<u>Sapling/Shrub Stratum (Plot size: 15 foot radius)</u>				Prevalence Index worksheet: Total % Cover of: _____ Multiply by: OBL species _____ x1 = _____ FACW species _____ x2 = _____ FAC species _____ x3 = _____ FACU species _____ x4 = _____ UPL species _____ x5 = _____ Column Totals: _____ (A) _____ (B) Prevalence Index = B/A = _____
1. <u><i>Cytisus scoparius</i></u>	<u>5</u>	<u>yes</u>	<u>UPL</u>	
2. <u><i>Rubus armeniacus</i></u>	<u>20</u>	<u>yes</u>	<u>FACU</u>	
3. _____	_____	_____	_____	
4. _____	_____	_____	_____	
5. _____	_____	_____	_____	
50% = <u>1</u> , 20% = <u>1</u>	<u>25</u>	= Total Cover		
<u>Herb Stratum (Plot size: 3 foot radius)</u>				
1. <u><i>Agrostis capillaris</i></u>	<u>10</u>	<u>no</u>	<u>FAC</u>	
2. <u><i>Equisetum arvense</i></u>	<u>10</u>	<u>no</u>	<u>FAC</u>	
3. <u><i>Juncus effusus</i></u>	<u>35</u>	<u>yes</u>	<u>FACW</u>	
4. <u><i>Phalaris arundinacea</i></u>	<u>15</u>	<u>yes</u>	<u>FACW</u>	
5. <u><i>Tanacetum vulgare</i></u>	<u>1</u>	<u>no</u>	<u>UPL</u>	
6. _____	_____	_____	_____	
7. _____	_____	_____	_____	
8. _____	_____	_____	_____	
9. _____	_____	_____	_____	
10. _____	_____	_____	_____	
11. _____	_____	_____	_____	
50% = <u>0</u> , 20% = <u>2</u>	<u>71</u>	= Total Cover		
<u>Woody Vine Stratum (Plot size: 3 foot radius)</u>				
1. _____	_____	_____	_____	
2. _____	_____	_____	_____	
50% = <u>0</u> , 20% = <u>0</u>	<u>0</u>	= Total Cover		
% Bare Ground in Herb Stratum <u>29</u>				
Hydrophytic Vegetation Indicators: <input type="checkbox"/> 1 – Rapid Test for Hydrophytic Vegetation <input checked="" type="checkbox"/> 2 - Dominance Test is >50% <input type="checkbox"/> 3 - Prevalence Index is ≤3.0 ¹ <input type="checkbox"/> 4 - Morphological Adaptations ¹ (Provide supporting data in Remarks or on a separate sheet) <input type="checkbox"/> 5 - Wetland Non-Vascular Plants ¹ <input type="checkbox"/> Problematic Hydrophytic Vegetation ¹ (Explain)				
¹ Indicators of hydric soil and wetland hydrology must be present, unless disturbed or problematic.				
Hydrophytic Vegetation Present? Yes <input checked="" type="checkbox"/> No <input type="checkbox"/>				

Remarks: 60% dominant wetland vegetation per the Dominance Test.

SOIL

Profile Description: (Describe to the depth needed to document the indicator or confirm the absence of indicators.)								
Depth (inches)	Matrix		Redox Features				Texture	Remarks
	Color (moist)	%	Color (moist)	%	Type ¹	Loc ²		
<u>0 to 10</u>	<u>10YR 3/4</u>	<u>100</u>	<u>None</u>	<u>None</u>	<u>None</u>	<u>None</u>	<u>Sandy loam</u>	<u>w/cobble & gravel</u>
<u>10 to 18+</u>	<u>None</u>	<u>100</u>	<u>None</u>	<u>None</u>	<u>None</u>	<u>None</u>	<u>Compact fill</u>	<u>w/cobble & gravel</u>

¹Type: C= Concentration, D=Depletion, RM=Reduced Matrix, CS=Covered or Coated Sand Grains. ²Location: PL=Pore Lining, M=Matrix

Hydric Soil Indicators: (Applicable to all LRRs, unless otherwise noted.)	Indicators for Problematic Hydric Soils ³ :
<input type="checkbox"/> Histosol (A1)	<input type="checkbox"/> 2 cm Muck (A10)
<input type="checkbox"/> Histic Epipedon (A2)	<input type="checkbox"/> Red Parent Material (TF2)
<input type="checkbox"/> Black Histic (A3)	<input type="checkbox"/> Very Shallow Dark Surface (TF12)
<input type="checkbox"/> Hydrogen Sulfide (A4)	<input type="checkbox"/> Other (Explain in Remarks)
<input type="checkbox"/> Depleted Below Dark Surface (A11)	
<input type="checkbox"/> Thick Dark Surface (A12)	
<input type="checkbox"/> Sandy Mucky Mineral (S1)	
<input type="checkbox"/> Sandy Gleyed Matrix (S4)	
<input type="checkbox"/> Sandy Redox (S5)	
<input type="checkbox"/> Stripped Matrix (S6)	
<input type="checkbox"/> Loamy Mucky Mineral (F1) (except MLRA 1)	
<input type="checkbox"/> Loamy Gleyed Matrix (F2)	
<input type="checkbox"/> Depleted Matrix (F3)	
<input type="checkbox"/> Redox Dark Surface (F6)	
<input type="checkbox"/> Depleted Dark Surface (F7)	
<input type="checkbox"/> Redox Depressions (F8)	

³Indicators of hydrophytic vegetation and wetland hydrology must be present, unless disturbed or problematic.

Restrictive Layer (if present): Type: <u>Fill prism</u> Depth (inches): <u>10 inches</u>	Hydric Soils Present? Yes <input type="checkbox"/> No <input checked="" type="checkbox"/>
---	--

Remarks: 4 chroma with no redox features with gravel and cobble, compacted fill features

HYDROLOGY

Wetland Hydrology Indicators:	
Primary Indicators (minimum of one required; check all that apply)	Secondary Indicators (2 or more required)
<input type="checkbox"/> Surface Water (A1)	<input type="checkbox"/> Water-Stained Leaves (B9)
<input type="checkbox"/> High Water Table (A2)	<input type="checkbox"/> Water-Stained Leaves (B9) (MLRA 1, 2, 4A, and 4B)
<input type="checkbox"/> Saturation (A3)	<input type="checkbox"/> Drainage Patterns (B10)
<input type="checkbox"/> Water Marks (B1)	<input type="checkbox"/> Dry-Season Water Table (C2)
<input type="checkbox"/> Sediment Deposits (B2)	<input type="checkbox"/> Saturation Visible on Aerial Imagery (C9)
<input type="checkbox"/> Drift Deposits (B3)	<input type="checkbox"/> Geomorphic Position (D2)
<input type="checkbox"/> Algal Mat or Crust (B4)	<input type="checkbox"/> Shallow Aquitard (D3)
<input type="checkbox"/> Iron Deposits (B5)	<input type="checkbox"/> FAC-Neutral Test (D5)
<input type="checkbox"/> Surface Soil Cracks (B6)	<input type="checkbox"/> Raised Ant Mounds (D6) (LRR A)
<input type="checkbox"/> Inundation Visible on Aerial Imagery (B7)	<input type="checkbox"/> Frost-Heave Hummocks (D7)
<input type="checkbox"/> Sparsely Vegetated Concave Surface (B8)	
<input type="checkbox"/> Salt Crust (B11)	
<input type="checkbox"/> Aquatic Invertebrates (B13)	
<input type="checkbox"/> Hydrogen Sulfide Odor (C1)	
<input type="checkbox"/> Oxidized Rhizospheres along Living Roots (C3)	
<input type="checkbox"/> Presence of Reduced Iron (C4)	
<input type="checkbox"/> Recent Iron Reduction in Tilled Soils (C6)	
<input type="checkbox"/> Stunted or Stresses Plants (D1) (LRR A)	
<input type="checkbox"/> Other (Explain in Remarks)	

Field Observations: Surface Water Present? Yes <input type="checkbox"/> No <input checked="" type="checkbox"/> Depth (inches): _____ Water Table Present? Yes <input type="checkbox"/> No <input checked="" type="checkbox"/> Depth (inches): _____ Saturation Present? (includes capillary fringe) Yes <input type="checkbox"/> No <input checked="" type="checkbox"/> Depth (inches): _____	Wetland Hydrology Present? Yes <input type="checkbox"/> No <input checked="" type="checkbox"/>
--	---

Describe Recorded Data (stream gauge, monitoring well, aerial photos, previous inspections), if available:

Remarks: No saturation or water table observed in sample plot

WETLAND DETERMINATION DATA FORM – Western Mountains, Valleys, and Coast Region

Project Site: Sound Transit East Link Extension Project City/County: Bellevue/King Sampling Date: Nov. 26, 2013
 Applicant/Owner: Sound Transit State: WA Sampling Point: Suspect Area SP3-U
 Investigator(s): C Douglas Section, Township, Range: S28, T24N, R5E
 Landform (hillslope, terrace, etc.): area adjacent to parking lot and TOS Local relief (concave, convex, none): concave Slope (%): 0% to 2%
 Subregion (LRR): A Lat: 47.62N Long: 122.18W Datum: _____
 Soil Map Unit Name: Everett gravelly sandy loam NWI classification: None Mapped
 Are climatic / hydrologic conditions on the site typical for this time of year? Yes No (If no, explain in Remarks.)
 Are Vegetation , Soil , or Hydrology , significantly disturbed? Are "Normal Circumstances" present? Yes No
 Are Vegetation , Soil , or Hydrology , naturally problematic? (If needed, explain any answers in Remarks.)

SUMMARY OF FINDINGS – Attach site map showing sampling point locations, transects, important features, etc.

Hydrophytic Vegetation Present?	Yes <input checked="" type="checkbox"/>	No <input type="checkbox"/>	Is the Sampled Area within a Wetland?		
Hydric Soil Present?	Yes <input type="checkbox"/>	No <input checked="" type="checkbox"/>		Yes <input type="checkbox"/>	No <input checked="" type="checkbox"/>
Wetland Hydrology Present?	Yes <input type="checkbox"/>	No <input checked="" type="checkbox"/>			
Remarks: Sample plot established in suspect area at the request of Sound Transit (Marti L.) to confirm wetland conditions were not present. Suspect area located in low area at edge of gravel parking lot and toe of slope of vegetated slope on western edge of property. Kelsey West Tributary Stream located to the northeast. Fill prism substrate within sample plot contains compacted fill conditions..					

VEGETATION – Use scientific names of plants

Tree Stratum (Plot size: 30 foot radius)	Absolute % Cover	Dominant Species?	Indicator Status	Dominance Test Worksheet:																
1. _____	_____	_____	_____	Number of Dominant Species That Are OBL, FACW, or FAC: <u>2</u> (A) Total Number of Dominant Species Across All Strata: <u>2</u> (B) Percent of Dominant Species That Are OBL, FACW, or FAC: <u>100</u> (A/B)																
2. _____	_____	_____	_____																	
3. _____	_____	_____	_____																	
4. _____	_____	_____	_____																	
50% = <u>0</u> , 20% = <u>0</u>	<u>0</u>	= Total Cover		Prevalence Index worksheet: <table style="width: 100%; border: none;"> <tr> <td style="text-align: center;">Total % Cover of:</td> <td style="text-align: center;">Multiply by:</td> </tr> <tr> <td>OBL species _____</td> <td>x1 = _____</td> </tr> <tr> <td>FACW species _____</td> <td>x2 = _____</td> </tr> <tr> <td>FAC species _____</td> <td>x3 = _____</td> </tr> <tr> <td>FACU species _____</td> <td>x4 = _____</td> </tr> <tr> <td>UPL species _____</td> <td>x5 = _____</td> </tr> <tr> <td>Column Totals: _____ (A)</td> <td>_____ (B)</td> </tr> <tr> <td colspan="2" style="text-align: center;">Prevalence Index = B/A = _____</td> </tr> </table>	Total % Cover of:	Multiply by:	OBL species _____	x1 = _____	FACW species _____	x2 = _____	FAC species _____	x3 = _____	FACU species _____	x4 = _____	UPL species _____	x5 = _____	Column Totals: _____ (A)	_____ (B)	Prevalence Index = B/A = _____	
Total % Cover of:	Multiply by:																			
OBL species _____	x1 = _____																			
FACW species _____	x2 = _____																			
FAC species _____	x3 = _____																			
FACU species _____	x4 = _____																			
UPL species _____	x5 = _____																			
Column Totals: _____ (A)	_____ (B)																			
Prevalence Index = B/A = _____																				
Sapling/Shrub Stratum (Plot size: 15 foot radius)																				
1. _____	_____	_____	_____																	
2. _____	_____	_____	_____																	
3. _____	_____	_____	_____																	
4. _____	_____	_____	_____																	
5. _____	_____	_____	_____																	
50% = <u>0</u> , 20% = <u>0</u>	<u>0</u>	= Total Cover																		
Herb Stratum (Plot size: 3 foot radius)																				
1. <u>Agrostis capillaris</u>	<u>5</u>	<u>no</u>	<u>FAC</u>																	
2. <u>Equisetum arvense</u>	<u>15</u>	<u>yes</u>	<u>FAC</u>																	
3. <u>Juncus effusus</u>	<u>50</u>	<u>yes</u>	<u>FACW</u>																	
4. _____	_____	_____	_____																	
5. _____	_____	_____	_____																	
6. _____	_____	_____	_____																	
7. _____	_____	_____	_____																	
8. _____	_____	_____	_____																	
9. _____	_____	_____	_____																	
10. _____	_____	_____	_____																	
11. _____	_____	_____	_____																	
50% = <u>1</u> , 20% = <u>1</u>	<u>65</u>	= Total Cover																		
Woody Vine Stratum (Plot size: 3 foot radius)																				
1. _____	_____	_____	_____																	
2. _____	_____	_____	_____																	
50% = <u>0</u> , 20% = <u>0</u>	<u>0</u>	= Total Cover																		
<table style="width: 100%; border: none;"> <tr> <td style="width: 35%;">Hydrophytic Vegetation Present?</td> <td style="width: 10%;">Yes <input checked="" type="checkbox"/></td> <td style="width: 10%;">No <input type="checkbox"/></td> </tr> </table>				Hydrophytic Vegetation Present?	Yes <input checked="" type="checkbox"/>	No <input type="checkbox"/>														
Hydrophytic Vegetation Present?	Yes <input checked="" type="checkbox"/>	No <input type="checkbox"/>																		
<table style="width: 100%; border: none;"> <tr> <td style="width: 35%;">Hydrophytic Vegetation Present?</td> <td style="width: 10%;">Yes <input checked="" type="checkbox"/></td> <td style="width: 10%;">No <input type="checkbox"/></td> </tr> </table>				Hydrophytic Vegetation Present?	Yes <input checked="" type="checkbox"/>	No <input type="checkbox"/>														
Hydrophytic Vegetation Present?	Yes <input checked="" type="checkbox"/>	No <input type="checkbox"/>																		
% Bare Ground in Herb Stratum <u>25</u>																				

Remarks: 100% dominant wetland vegetation per the Dominance Test, only 3 species in sample plot.

SOIL

Profile Description: (Describe to the depth needed to document the indicator or confirm the absence of indicators.)								
Depth (inches)	Matrix		Redox Features				Texture	Remarks
	Color (moist)	%	Color (moist)	%	Type ¹	Loc ²		
0 to 5	10YR 4/3	100	None	None	None	None	Sandy loam	w/cobble & gravel
5 to 18+	None	100	None	None	None	None	Compact fill	w/cobble & gravel
_____	_____	_____	_____	_____	_____	_____	_____	_____
_____	_____	_____	_____	_____	_____	_____	_____	_____
_____	_____	_____	_____	_____	_____	_____	_____	_____
_____	_____	_____	_____	_____	_____	_____	_____	_____
_____	_____	_____	_____	_____	_____	_____	_____	_____
¹ Type: C= Concentration, D=Depletion, RM=Reduced Matrix, CS=Covered or Coated Sand Grains.					² Location: PL=Pore Lining, M=Matrix			
Hydric Soil Indicators: (Applicable to all LRRs, unless otherwise noted.)						Indicators for Problematic Hydric Soils³:		
<input type="checkbox"/> Histosol (A1)			<input type="checkbox"/> Sandy Redox (S5)			<input type="checkbox"/> 2 cm Muck (A10)		
<input type="checkbox"/> Histic Epipedon (A2)			<input type="checkbox"/> Stripped Matrix (S6)			<input type="checkbox"/> Red Parent Material (TF2)		
<input type="checkbox"/> Black Histic (A3)			<input type="checkbox"/> Loamy Mucky Mineral (F1) (except MLRA 1)			<input type="checkbox"/> Very Shallow Dark Surface (TF12)		
<input type="checkbox"/> Hydrogen Sulfide (A4)			<input type="checkbox"/> Loamy Gleyed Matrix (F2)			<input type="checkbox"/> Other (Explain in Remarks)		
<input type="checkbox"/> Depleted Below Dark Surface (A11)			<input type="checkbox"/> Depleted Matrix (F3)			³ Indicators of hydrophytic vegetation and wetland hydrology must be present, unless disturbed or problematic.		
<input type="checkbox"/> Thick Dark Surface (A12)			<input type="checkbox"/> Redox Dark Surface (F6)					
<input type="checkbox"/> Sandy Mucky Mineral (S1)			<input type="checkbox"/> Depleted Dark Surface (F7)					
<input type="checkbox"/> Sandy Gleyed Matrix (S4)			<input type="checkbox"/> Redox Depressions (F8)					
Restrictive Layer (if present):					Hydric Soils Present?			
Type: <u>Fill prism</u>					Yes <input type="checkbox"/> No <input checked="" type="checkbox"/>			
Depth (inches): <u>5 inches</u>								
Remarks: 3 chroma with no redox features with gravel and cobble, compacted fill features								

HYDROLOGY

Wetland Hydrology Indicators:			
Primary Indicators (minimum of one required; check all that apply)		Secondary Indicators (2 or more required)	
<input type="checkbox"/> Surface Water (A1)	<input type="checkbox"/> Water-Stained Leaves (B9)	<input type="checkbox"/> Water-Stained Leaves (B9)	
<input type="checkbox"/> High Water Table (A2)	(except MLRA 1, 2, 4A, and 4B)	(MLRA 1, 2, 4A, and 4B)	
<input type="checkbox"/> Saturation (A3)	<input type="checkbox"/> Salt Crust (B11)	<input type="checkbox"/> Drainage Patterns (B10)	
<input type="checkbox"/> Water Marks (B1)	<input type="checkbox"/> Aquatic Invertebrates (B13)	<input type="checkbox"/> Dry-Season Water Table (C2)	
<input type="checkbox"/> Sediment Deposits (B2)	<input type="checkbox"/> Hydrogen Sulfide Odor (C1)	<input type="checkbox"/> Saturation Visible on Aerial Imagery (C9)	
<input type="checkbox"/> Drift Deposits (B3)	<input type="checkbox"/> Oxidized Rhizospheres along Living Roots (C3)	<input type="checkbox"/> Geomorphic Position (D2)	
<input type="checkbox"/> Algal Mat or Crust (B4)	<input type="checkbox"/> Presence of Reduced Iron (C4)	<input type="checkbox"/> Shallow Aquitard (D3)	
<input type="checkbox"/> Iron Deposits (B5)	<input type="checkbox"/> Recent Iron Reduction in Tilled Soils (C6)	<input type="checkbox"/> FAC-Neutral Test (D5)	
<input type="checkbox"/> Surface Soil Cracks (B6)	<input type="checkbox"/> Stunted or Stresses Plants (D1) (LRR A)	<input type="checkbox"/> Raised Ant Mounds (D6) (LRR A)	
<input type="checkbox"/> Inundation Visible on Aerial Imagery (B7)	<input type="checkbox"/> Other (Explain in Remarks)	<input type="checkbox"/> Frost-Heave Hummocks (D7)	
<input type="checkbox"/> Sparsely Vegetated Concave Surface (B8)			
Field Observations:		Wetland Hydrology Present?	
Surface Water Present?	Yes <input type="checkbox"/> No <input checked="" type="checkbox"/>	Depth (inches):	_____
Water Table Present?	Yes <input type="checkbox"/> No <input checked="" type="checkbox"/>	Depth (inches):	_____
Saturation Present? (includes capillary fringe)	Yes <input type="checkbox"/> No <input checked="" type="checkbox"/>	Depth (inches):	_____
Describe Recorded Data (stream gauge, monitoring well, aerial photos, previous inspections), if available:		Yes <input type="checkbox"/> No <input checked="" type="checkbox"/>	
Remarks: No saturation or water table observed in sample plot			

WETLAND DETERMINATION DATA FORM – Western Mountains, Valleys, and Coast Region

Project Site: Sound Transit East Link Extension Project City/County: Bellevue/King Sampling Date: Nov. 26, 2013
 Applicant/Owner: Sound Transit State: WA Sampling Point: Suspect Area SP4-U
 Investigator(s): C Douglas Section, Township, Range: S28, T24N, R5E
 Landform (hillslope, terrace, etc.): area adjacent to parking lot and TOS Local relief (concave, convex, none): concave Slope (%): 0% to 2%
 Subregion (LRR): A Lat: 47.62N Long: 122.18W Datum: _____
 Soil Map Unit Name: Everett gravelly sandy loam NWI classification: None Mapped
 Are climatic / hydrologic conditions on the site typical for this time of year? Yes No (If no, explain in Remarks.)
 Are Vegetation , Soil , or Hydrology , significantly disturbed? Are "Normal Circumstances" present? Yes No
 Are Vegetation , Soil , or Hydrology , naturally problematic? (If needed, explain any answers in Remarks.)

SUMMARY OF FINDINGS – Attach site map showing sampling point locations, transects, important features, etc.

Hydrophytic Vegetation Present?	Yes <input checked="" type="checkbox"/>	No <input type="checkbox"/>	Is the Sampled Area within a Wetland?		
Hydric Soil Present?	Yes <input type="checkbox"/>	No <input checked="" type="checkbox"/>		Yes <input type="checkbox"/>	No <input checked="" type="checkbox"/>
Wetland Hydrology Present?	Yes <input type="checkbox"/>	No <input checked="" type="checkbox"/>			
Remarks: Sample plot established in suspect area at the request of Sound Transit (Marti L.) to confirm wetland conditions were not present. Suspect area located in low area at edge of gravel parking lot and toe of slope of vegetated slope on southwest edge of property. Kelsey West Tributary Stream located to the northeast. Fill prism substrate within sample plot contains compacted fill conditions..					

VEGETATION – Use scientific names of plants

Tree Stratum (Plot size: 30 foot radius)	Absolute % Cover	Dominant Species?	Indicator Status	Dominance Test Worksheet:																
1. _____	_____	_____	_____	Number of Dominant Species That Are OBL, FACW, or FAC: <u>2</u> (A) Total Number of Dominant Species Across All Strata: <u>2</u> (B) Percent of Dominant Species That Are OBL, FACW, or FAC: <u>100</u> (A/B)																
2. _____	_____	_____	_____																	
3. _____	_____	_____	_____																	
4. _____	_____	_____	_____																	
50% = <u>0</u> , 20% = <u>0</u>	<u>0</u>	= Total Cover		Prevalence Index worksheet: <table style="width: 100%; border: none;"> <tr> <td style="text-align: center;"><u>Total % Cover of:</u></td> <td style="text-align: center;"><u>Multiply by:</u></td> </tr> <tr> <td>OBL species _____</td> <td>x1 = _____</td> </tr> <tr> <td>FACW species _____</td> <td>x2 = _____</td> </tr> <tr> <td>FAC species _____</td> <td>x3 = _____</td> </tr> <tr> <td>FACU species _____</td> <td>x4 = _____</td> </tr> <tr> <td>UPL species _____</td> <td>x5 = _____</td> </tr> <tr> <td>Column Totals: _____ (A)</td> <td>_____ (B)</td> </tr> <tr> <td colspan="2" style="text-align: center;">Prevalence Index = B/A = _____</td> </tr> </table>	<u>Total % Cover of:</u>	<u>Multiply by:</u>	OBL species _____	x1 = _____	FACW species _____	x2 = _____	FAC species _____	x3 = _____	FACU species _____	x4 = _____	UPL species _____	x5 = _____	Column Totals: _____ (A)	_____ (B)	Prevalence Index = B/A = _____	
<u>Total % Cover of:</u>	<u>Multiply by:</u>																			
OBL species _____	x1 = _____																			
FACW species _____	x2 = _____																			
FAC species _____	x3 = _____																			
FACU species _____	x4 = _____																			
UPL species _____	x5 = _____																			
Column Totals: _____ (A)	_____ (B)																			
Prevalence Index = B/A = _____																				
Sapling/Shrub Stratum (Plot size: 15 foot radius)																				
1. _____	_____	_____	_____	Hydrophytic Vegetation Indicators: <input type="checkbox"/> 1 – Rapid Test for Hydrophytic Vegetation <input checked="" type="checkbox"/> 2 - Dominance Test is >50% <input type="checkbox"/> 3 - Prevalence Index is $\leq 3.0^1$ <input type="checkbox"/> 4 - Morphological Adaptations ¹ (Provide supporting data in Remarks or on a separate sheet) <input type="checkbox"/> 5 - Wetland Non-Vascular Plants ¹ <input type="checkbox"/> Problematic Hydrophytic Vegetation ¹ (Explain)																
2. _____	_____	_____	_____																	
3. _____	_____	_____	_____																	
4. _____	_____	_____	_____																	
5. _____	_____	_____	_____																	
50% = <u>0</u> , 20% = <u>0</u>	<u>0</u>	= Total Cover																		
Herb Stratum (Plot size: 3 foot radius)																				
1. <u>Agrostis capillaris</u>	<u>1</u>	<u>no</u>	<u>FAC</u>	¹ Indicators of hydric soil and wetland hydrology must be present, unless disturbed or problematic.																
2. <u>Equisetum arvense</u>	<u>20</u>	<u>yes</u>	<u>FAC</u>																	
3. <u>Juncus effusus</u>	<u>60</u>	<u>yes</u>	<u>FACW</u>																	
4. _____	_____	_____	_____																	
5. _____	_____	_____	_____																	
6. _____	_____	_____	_____																	
7. _____	_____	_____	_____																	
8. _____	_____	_____	_____																	
9. _____	_____	_____	_____																	
10. _____	_____	_____	_____																	
11. _____	_____	_____	_____																	
50% = <u>1</u> , 20% = <u>1</u>	<u>86</u>	= Total Cover																		
Woody Vine Stratum (Plot size: 3 foot radius)																				
1. _____	_____	_____	_____	Hydrophytic Vegetation Present? Yes <input checked="" type="checkbox"/> No <input type="checkbox"/>																
2. _____	_____	_____	_____																	
50% = <u>0</u> , 20% = <u>0</u>	<u>0</u>	= Total Cover																		
% Bare Ground in Herb Stratum <u>14</u>																				

Remarks: 100% dominant wetland vegetation per the Dominance Test, only 3 species in sample plot.

SOIL

Profile Description: (Describe to the depth needed to document the indicator or confirm the absence of indicators.)								
Depth (inches)	Matrix		Redox Features				Texture	Remarks
	Color (moist)	%	Color (moist)	%	Type ¹	Loc ²		
0 to 7	10YR 4/3	100	None	None	None	None	Sandy loam	w/cobble & gravel
7 to 18+	None	100	None	None	None	None	Compact fill	w/cobble & gravel

¹Type: C= Concentration, D=Depletion, RM=Reduced Matrix, CS=Covered or Coated Sand Grains. ²Location: PL=Pore Lining, M=Matrix

Hydric Soil Indicators: (Applicable to all LRRs, unless otherwise noted.)			Indicators for Problematic Hydric Soils ³ :		
<input type="checkbox"/> Histosol (A1)	<input type="checkbox"/> Sandy Redox (S5)	<input type="checkbox"/> 2 cm Muck (A10)			
<input type="checkbox"/> Histic Epipedon (A2)	<input type="checkbox"/> Stripped Matrix (S6)	<input type="checkbox"/> Red Parent Material (TF2)			
<input type="checkbox"/> Black Histic (A3)	<input type="checkbox"/> Loamy Mucky Mineral (F1) (except MLRA 1)	<input type="checkbox"/> Very Shallow Dark Surface (TF12)			
<input type="checkbox"/> Hydrogen Sulfide (A4)	<input type="checkbox"/> Loamy Gleyed Matrix (F2)	<input type="checkbox"/> Other (Explain in Remarks)			
<input type="checkbox"/> Depleted Below Dark Surface (A11)	<input type="checkbox"/> Depleted Matrix (F3)				
<input type="checkbox"/> Thick Dark Surface (A12)	<input type="checkbox"/> Redox Dark Surface (F6)				
<input type="checkbox"/> Sandy Mucky Mineral (S1)	<input type="checkbox"/> Depleted Dark Surface (F7)				
<input type="checkbox"/> Sandy Gleyed Matrix (S4)	<input type="checkbox"/> Redox Depressions (F8)				

³Indicators of hydrophytic vegetation and wetland hydrology must be present, unless disturbed or problematic.

Restrictive Layer (if present): Type: <u>Fill prism</u> Depth (inches): <u>7 inches</u>	Hydric Soils Present? Yes <input type="checkbox"/> No <input checked="" type="checkbox"/>
--	--

Remarks: 3 chroma with no redox features with gravel and cobble, compacted fill features

HYDROLOGY

Wetland Hydrology Indicators:			
Primary Indicators (minimum of one required; check all that apply)		Secondary Indicators (2 or more required)	
<input type="checkbox"/> Surface Water (A1)	<input type="checkbox"/> Water-Stained Leaves (B9)	<input type="checkbox"/> Water-Stained Leaves (B9)	
<input type="checkbox"/> High Water Table (A2)	(except MLRA 1, 2, 4A, and 4B)	(MLRA 1, 2, 4A, and 4B)	
<input type="checkbox"/> Saturation (A3)	<input type="checkbox"/> Salt Crust (B11)	<input type="checkbox"/> Drainage Patterns (B10)	
<input type="checkbox"/> Water Marks (B1)	<input type="checkbox"/> Aquatic Invertebrates (B13)	<input type="checkbox"/> Dry-Season Water Table (C2)	
<input type="checkbox"/> Sediment Deposits (B2)	<input type="checkbox"/> Hydrogen Sulfide Odor (C1)	<input type="checkbox"/> Saturation Visible on Aerial Imagery (C9)	
<input type="checkbox"/> Drift Deposits (B3)	<input type="checkbox"/> Oxidized Rhizospheres along Living Roots (C3)	<input type="checkbox"/> Geomorphic Position (D2)	
<input type="checkbox"/> Algal Mat or Crust (B4)	<input type="checkbox"/> Presence of Reduced Iron (C4)	<input type="checkbox"/> Shallow Aquitard (D3)	
<input type="checkbox"/> Iron Deposits (B5)	<input type="checkbox"/> Recent Iron Reduction in Tilled Soils (C6)	<input type="checkbox"/> FAC-Neutral Test (D5)	
<input type="checkbox"/> Surface Soil Cracks (B6)	<input type="checkbox"/> Stunted or Stresses Plants (D1) (LRR A)	<input type="checkbox"/> Raised Ant Mounds (D6) (LRR A)	
<input type="checkbox"/> Inundation Visible on Aerial Imagery (B7)	<input type="checkbox"/> Other (Explain in Remarks)	<input type="checkbox"/> Frost-Heave Hummocks (D7)	
<input type="checkbox"/> Sparsely Vegetated Concave Surface (B8)			

Field Observations: Surface Water Present? Yes <input type="checkbox"/> No <input checked="" type="checkbox"/> Depth (inches): _____ Water Table Present? Yes <input type="checkbox"/> No <input checked="" type="checkbox"/> Depth (inches): _____ Saturation Present? (includes capillary fringe) Yes <input type="checkbox"/> No <input checked="" type="checkbox"/> Depth (inches): _____	Wetland Hydrology Present? Yes <input type="checkbox"/> No <input checked="" type="checkbox"/>
---	---

Describe Recorded Data (stream gauge, monitoring well, aerial photos, previous inspections), if available:

Remarks: No saturation or water table observed in sample plot

WETLAND DETERMINATION DATA FORM – Western Mountains, Valleys, and Coast Region

Project Site: Sound Transit East Link Extension Project City/County: Bellevue/King Sampling Date: April 23, 2013
 Applicant/Owner: Sound Transit State: WA Sampling Point: Valley Creek SP1W
 Investigator(s): C Douglas & J. Pursley Section, Township, Range: S28, T24N, R5E
 Landform (hillslope, terrace, etc.): Narrow area between development Local relief (concave, convex, none): concave Slope (%): 0% to 2%
 Subregion (LRR): A Lat: 47.62N Long: 122.15W Datum: _____
 Soil Map Unit Name: Bellingham silt loam NWI classification: None Mapped
 Are climatic / hydrologic conditions on the site typical for this time of year? Yes No (If no, explain in Remarks.)
 Are Vegetation , Soil , or Hydrology , significantly disturbed? Are "Normal Circumstances" present? Yes No
 Are Vegetation , Soil , or Hydrology , naturally problematic? (If needed, explain any answers in Remarks.)

SUMMARY OF FINDINGS – Attach site map showing sampling point locations, transects, important features, etc.

Hydrophytic Vegetation Present?	Yes <input checked="" type="checkbox"/>	No <input type="checkbox"/>	Is the Sampled Area within a Wetland?	Yes <input checked="" type="checkbox"/>	No <input type="checkbox"/>
Hydric Soil Present?	Yes <input checked="" type="checkbox"/>	No <input type="checkbox"/>		Yes <input checked="" type="checkbox"/>	No <input type="checkbox"/>
Wetland Hydrology Present?	Yes <input checked="" type="checkbox"/>	No <input type="checkbox"/>		Yes <input checked="" type="checkbox"/>	No <input type="checkbox"/>
Remarks: Wetland is located in narrow area between commercial development and the SR 520 ROW fill prism. Wetland is a narrow depression associated with Valley Creek with culverts entering wetland in several locations. Wetland includes depressional and riverine HGM classes.					

VEGETATION – Use scientific names of plants

Tree Stratum (Plot size: 30 foot radius)	Absolute % Cover	Dominant Species?	Indicator Status	Dominance Test Worksheet:																
1. <u><i>Alnus rubra</i></u>	40	yes	FAC	Number of Dominant Species That Are OBL, FACW, or FAC: <u>5</u> (A) Total Number of Dominant Species Across All Strata: <u>6</u> (B) Percent of Dominant Species That Are OBL, FACW, or FAC: <u>83</u> (A/B)																
2. <u><i>Populus trichocarpa</i></u>	5	no	FAC																	
3. <u><i>Salix lasiandra</i></u>	5	no	FACW																	
4. _____	_____	_____	_____																	
50% = <u>1</u> , 20% = <u>0</u>	50	= Total Cover		Prevalence Index worksheet: <table style="width: 100%; border: none;"> <tr> <td style="text-align: right;">Total % Cover of:</td> <td style="text-align: left;">Multiply by:</td> </tr> <tr> <td>OBL species _____</td> <td>x1 = _____</td> </tr> <tr> <td>FACW species _____</td> <td>x2 = _____</td> </tr> <tr> <td>FAC species _____</td> <td>x3 = _____</td> </tr> <tr> <td>FACU species _____</td> <td>x4 = _____</td> </tr> <tr> <td>UPL species _____</td> <td>x5 = _____</td> </tr> <tr> <td>Column Totals: _____ (A)</td> <td>_____ (B)</td> </tr> <tr> <td colspan="2" style="text-align: center;">Prevalence Index = B/A = _____</td> </tr> </table>	Total % Cover of:	Multiply by:	OBL species _____	x1 = _____	FACW species _____	x2 = _____	FAC species _____	x3 = _____	FACU species _____	x4 = _____	UPL species _____	x5 = _____	Column Totals: _____ (A)	_____ (B)	Prevalence Index = B/A = _____	
Total % Cover of:	Multiply by:																			
OBL species _____	x1 = _____																			
FACW species _____	x2 = _____																			
FAC species _____	x3 = _____																			
FACU species _____	x4 = _____																			
UPL species _____	x5 = _____																			
Column Totals: _____ (A)	_____ (B)																			
Prevalence Index = B/A = _____																				
Sapling/Shrub Stratum (Plot size: 15 foot radius)																				
1. <u><i>Rubus armeniacus</i></u>	60	yes	FACU	Hydrophytic Vegetation Indicators: <input type="checkbox"/> 1 – Rapid Test for Hydrophytic Vegetation <input checked="" type="checkbox"/> 2 - Dominance Test is >50% <input type="checkbox"/> 3 - Prevalence Index is $\leq 3.0^1$ <input type="checkbox"/> 4 - Morphological Adaptations ¹ (Provide supporting data in Remarks or on a separate sheet) <input type="checkbox"/> 5 - Wetland Non-Vascular Plants ¹ <input type="checkbox"/> Problematic Hydrophytic Vegetation ¹ (Explain) ¹ Indicators of hydric soil and wetland hydrology must be present, unless disturbed or problematic.																
2. <u><i>Solanum dulcamara</i></u>	5	no	FAC																	
3. <u><i>Spiraea douglasii</i></u>	20	yes	FACW																	
4. _____	_____	_____	_____																	
5. _____	_____	_____	_____																	
50% = <u>1</u> , 20% = <u>1</u>	85	= Total Cover																		
Herb Stratum (Plot size: 3 foot radius)																				
1. <u><i>Epilobium watsonii</i></u>	5	no	FACW	Hydrophytic Vegetation Present? Yes <input checked="" type="checkbox"/> No <input type="checkbox"/>																
2. <u><i>Equisetum arvense</i></u>	20	yes	FAC																	
3. <u><i>Phalaris arundinacea</i></u>	40	yes	FACW																	
4. <u><i>Typha latifolia</i></u>	20	yes	OBL																	
5. _____	_____	_____	_____																	
6. _____	_____	_____	_____																	
7. _____	_____	_____	_____																	
8. _____	_____	_____	_____																	
9. _____	_____	_____	_____																	
10. _____	_____	_____	_____																	
11. _____	_____	_____	_____																	
50% = <u>0</u> , 20% = <u>3</u>	85	= Total Cover																		
Woody Vine Stratum (Plot size: 3 foot radius)																				
1. _____	_____	_____	_____	Hydrophytic Vegetation Present? Yes <input checked="" type="checkbox"/> No <input type="checkbox"/>																
2. _____	_____	_____	_____																	
50% = _____, 20% = _____	0	= Total Cover																		
% Bare Ground in Herb Stratum <u>0</u>																				

Remarks: 83% dominant wetland vegetation per the Dominance Test

SOIL

Profile Description: (Describe to the depth needed to document the indicator or confirm the absence of indicators.)

Depth (inches)	Matrix		Redox Features				Texture	Remarks
	Color (moist)	%	Color (moist)	%	Type ¹	Loc ²		
0 to 1	Duff	100	None	None	None	None	Duff	w/leaf litter
1 to 7	10YR 3/1	100	None	None	None	None	Sandy loam	
7 to 18+	10YR 3/1	95	10YR 5/3	5	D	M	Sand	
_____	_____	_____	_____	_____	_____	_____	_____	_____
_____	_____	_____	_____	_____	_____	_____	_____	_____
_____	_____	_____	_____	_____	_____	_____	_____	_____
_____	_____	_____	_____	_____	_____	_____	_____	_____

¹Type: C= Concentration, D=Depletion, RM=Reduced Matrix, CS=Covered or Coated Sand Grains. ²Location: PL=Pore Lining, M=Matrix

Hydric Soil Indicators: (Applicable to all LRRs, unless otherwise noted.)

- Histosol (A1) Sandy Redox (S5)
- Histic Epipedon (A2) Stripped Matrix (S6)
- Black Histic (A3) Loamy Mucky Mineral (F1) **(except MLRA 1)**
- Hydrogen Sulfide (A4) Loamy Gleyed Matrix (F2)
- Depleted Below Dark Surface (A11) Depleted Matrix (F3)
- Thick Dark Surface (A12) Redox Dark Surface (F6)
- Sandy Mucky Mineral (S1) Depleted Dark Surface (F7)
- Sandy Gleyed Matrix (S4) Redox Depressions (F8)

Indicators for Problematic Hydric Soils³:

- 2 cm Muck (A10)
- Red Parent Material (TF2)
- Very Shallow Dark Surface (TF12)
- Other (Explain in Remarks)

³Indicators of hydrophytic vegetation and wetland hydrology must be present, unless disturbed or problematic.

Restrictive Layer (if present):

Type: _____
 Depth (inches): _____

Hydric Soils Present? Yes No

Remarks: 1 chroma with redox features

HYDROLOGY

Wetland Hydrology Indicators:

Primary Indicators (minimum of one required; check all that apply)

Secondary Indicators (2 or more required)

- | | | |
|--|---|--|
| <input type="checkbox"/> Surface Water (A1) | <input checked="" type="checkbox"/> Water-Stained Leaves (B9) | <input type="checkbox"/> Water-Stained Leaves (B9) |
| <input checked="" type="checkbox"/> High Water Table (A2) | (except MLRA 1, 2, 4A, and 4B) | (MLRA 1, 2, 4A, and 4B) |
| <input checked="" type="checkbox"/> Saturation (A3) | <input type="checkbox"/> Salt Crust (B11) | <input type="checkbox"/> Drainage Patterns (B10) |
| <input checked="" type="checkbox"/> Water Marks (B1) | <input type="checkbox"/> Aquatic Invertebrates (B13) | <input type="checkbox"/> Dry-Season Water Table (C2) |
| <input type="checkbox"/> Sediment Deposits (B2) | <input type="checkbox"/> Hydrogen Sulfide Odor (C1) | <input type="checkbox"/> Saturation Visible on Aerial Imagery (C9) |
| <input type="checkbox"/> Drift Deposits (B3) | <input type="checkbox"/> Oxidized Rhizospheres along Living Roots (C3) | <input type="checkbox"/> Geomorphic Position (D2) |
| <input type="checkbox"/> Algal Mat or Crust (B4) | <input type="checkbox"/> Presence of Reduced Iron (C4) | <input type="checkbox"/> Shallow Aquitard (D3) |
| <input type="checkbox"/> Iron Deposits (B5) | <input type="checkbox"/> Recent Iron Reduction in Tilled Soils (C6) | <input type="checkbox"/> FAC-Neutral Test (D5) |
| <input type="checkbox"/> Surface Soil Cracks (B6) | <input type="checkbox"/> Stunted or Stresses Plants (D1) (LRR A) | <input type="checkbox"/> Raised Ant Mounds (D6) (LRR A) |
| <input type="checkbox"/> Inundation Visible on Aerial Imagery (B7) | <input type="checkbox"/> Other (Explain in Remarks) | <input type="checkbox"/> Frost-Heave Hummocks (D7) |
| <input type="checkbox"/> Sparsely Vegetated Concave Surface (B8) | | |

Field Observations:

Surface Water Present? Yes No Depth (inches): _____
 Water Table Present? Yes No Depth (inches): 8 inches
 Saturation Present? (includes capillary fringe) Yes No Depth (inches): Surface

Wetland Hydrology Present? Yes No

Describe Recorded Data (stream gauge, monitoring well, aerial photos, previous inspections), if available:

Remarks: Saturation at surface and water table 8 inches from surface

WETLAND DETERMINATION DATA FORM – Western Mountains, Valleys, and Coast Region

Project Site: Sound Transit East Link Extension Project City/County: Bellevue/King Sampling Date: April 23, 2013
 Applicant/Owner: Sound Transit State: WA Sampling Point: Valley Creek SP2U
 Investigator(s): C Douglas & J. Pursley Section, Township, Range: S28, T24N, R5E
 Landform (hillslope, terrace, etc.): Narrow area between development Local relief (concave, convex, none): concave Slope (%): 0% to 2%
 Subregion (LRR): A Lat: 47.62N Long: 122.15W Datum: _____
 Soil Map Unit Name: Bellingham silt loam NWI classification: None Mapped
 Are climatic / hydrologic conditions on the site typical for this time of year? Yes No (If no, explain in Remarks.)
 Are Vegetation , Soil , or Hydrology , significantly disturbed? Are "Normal Circumstances" present? Yes No
 Are Vegetation , Soil , or Hydrology , naturally problematic? (If needed, explain any answers in Remarks.)

SUMMARY OF FINDINGS – Attach site map showing sampling point locations, transects, important features, etc.

Hydrophytic Vegetation Present?	Yes <input checked="" type="checkbox"/>	No <input type="checkbox"/>	Is the Sampled Area within a Wetland?	Yes <input type="checkbox"/>	No <input checked="" type="checkbox"/>
Hydric Soil Present?	Yes <input type="checkbox"/>	No <input checked="" type="checkbox"/>		Yes <input type="checkbox"/>	No <input checked="" type="checkbox"/>
Wetland Hydrology Present?	Yes <input type="checkbox"/>	No <input checked="" type="checkbox"/>		Yes <input type="checkbox"/>	No <input checked="" type="checkbox"/>
Remarks: Wetland is located in narrow area between commercial development and the SR 520 ROW fill prism. Wetland is a narrow depression associated with Valley Creek with culverts entering wetland in several locations. Wetland includes depressional and riverine HGM classes.					

VEGETATION – Use scientific names of plants

Tree Stratum (Plot size: 30 foot radius)	Absolute % Cover	Dominant Species?	Indicator Status	Dominance Test Worksheet:																																
1. <u><i>Alnus rubra</i></u>	95	yes	FAC	Number of Dominant Species That Are OBL, FACW, or FAC: 4 (A) Total Number of Dominant Species Across All Strata: 6 (B) Percent of Dominant Species That Are OBL, FACW, or FAC: 67 (A/B)																																
2. <u><i>Populus trichocarpa</i></u>	40	yes	FAC																																	
3. <u><i>Pseudotsuga menziesii</i></u>	10	no	FACU																																	
4. _____	_____	_____	_____																																	
50% = 1, 20% = 1	100	= Total Cover		Prevalence Index worksheet: <table style="width: 100%; border: none;"> <tr> <td style="text-align: right;">Total % Cover of:</td> <td style="text-align: center;">_____</td> <td style="text-align: right;">Multiply by:</td> <td style="text-align: center;">_____</td> </tr> <tr> <td>OBL species</td> <td style="text-align: center;">_____</td> <td>x1 =</td> <td style="text-align: center;">_____</td> </tr> <tr> <td>FACW species</td> <td style="text-align: center;">_____</td> <td>x2 =</td> <td style="text-align: center;">_____</td> </tr> <tr> <td>FAC species</td> <td style="text-align: center;">_____</td> <td>x3 =</td> <td style="text-align: center;">_____</td> </tr> <tr> <td>FACU species</td> <td style="text-align: center;">_____</td> <td>x4 =</td> <td style="text-align: center;">_____</td> </tr> <tr> <td>UPL species</td> <td style="text-align: center;">_____</td> <td>x5 =</td> <td style="text-align: center;">_____</td> </tr> <tr> <td>Column Totals:</td> <td style="text-align: center;">_____ (A)</td> <td></td> <td style="text-align: center;">_____ (B)</td> </tr> <tr> <td colspan="4" style="text-align: right;">Prevalence Index = B/A = _____</td> </tr> </table>	Total % Cover of:	_____	Multiply by:	_____	OBL species	_____	x1 =	_____	FACW species	_____	x2 =	_____	FAC species	_____	x3 =	_____	FACU species	_____	x4 =	_____	UPL species	_____	x5 =	_____	Column Totals:	_____ (A)		_____ (B)	Prevalence Index = B/A = _____			
Total % Cover of:	_____	Multiply by:	_____																																	
OBL species	_____	x1 =	_____																																	
FACW species	_____	x2 =	_____																																	
FAC species	_____	x3 =	_____																																	
FACU species	_____	x4 =	_____																																	
UPL species	_____	x5 =	_____																																	
Column Totals:	_____ (A)		_____ (B)																																	
Prevalence Index = B/A = _____																																				
Sapling/Shrub Stratum (Plot size: 15 foot radius)																																				
1. <u><i>Cornus sericea</i></u>	10	no	FACW																																	
2. <u><i>Oemleria cerasiformis</i></u>	25	yes	FACU																																	
3. <u><i>Rubus armeniacus</i></u>	40	yes	FACU																																	
4. <u><i>Spiraea douglasii</i></u>	30	yes	FACW																																	
5. _____	_____	_____	_____																																	
50% = 0, 20% = 3	100	= Total Cover																																		
Herb Stratum (Plot size: 3 foot radius)																																				
1. <u><i>Equisetum arvense</i></u>	30	yes	FAC	Hydrophytic Vegetation Indicators: <input type="checkbox"/> 1 – Rapid Test for Hydrophytic Vegetation <input checked="" type="checkbox"/> 2 - Dominance Test is >50% <input type="checkbox"/> 3 - Prevalence Index is ≤3.0 ¹ <input type="checkbox"/> 4 - Morphological Adaptations ¹ (Provide supporting data in Remarks or on a separate sheet) <input type="checkbox"/> 5 - Wetland Non-Vascular Plants ¹ <input type="checkbox"/> Problematic Hydrophytic Vegetation ¹ (Explain) ¹ Indicators of hydric soil and wetland hydrology must be present, unless disturbed or problematic.																																
2. <u><i>Phalaris arundinacea</i></u>	10	no	FACW																																	
3. _____	_____	_____	_____																																	
4. _____	_____	_____	_____																																	
5. _____	_____	_____	_____																																	
6. _____	_____	_____	_____																																	
7. _____	_____	_____	_____																																	
8. _____	_____	_____	_____																																	
9. _____	_____	_____	_____																																	
10. _____	_____	_____	_____																																	
11. _____	_____	_____	_____																																	
50% = 1, 20% = 0	40	= Total Cover																																		
Woody Vine Stratum (Plot size: 3 foot radius)																																				
1. _____	_____	_____	_____																																	
2. _____	_____	_____	_____																																	
50% = _____, 20% = _____	0	= Total Cover																																		
% Bare Ground in Herb Stratum <u>60</u>																																				
Hydrophytic Vegetation Present? Yes <input checked="" type="checkbox"/> No <input type="checkbox"/>																																				
Remarks: 67% dominant wetland vegetation per the Dominance Test..																																				

SOIL

Sampling Point: Valley Creek SP2U

Profile Description: (Describe to the depth needed to document the indicator or confirm the absence of indicators.)								
Depth (inches)	Matrix		Redox Features				Texture	Remarks
	Color (moist)	%	Color (moist)	%	Type ¹	Loc ²		
0 to 4	10YR 4/4	100	None	None	None	None	Loam	
4 to 18+	Fill	100	None	None	None	None	Fill	w/angular rock
_____	_____	_____	_____	_____	_____	_____	_____	_____
_____	_____	_____	_____	_____	_____	_____	_____	_____
_____	_____	_____	_____	_____	_____	_____	_____	_____
_____	_____	_____	_____	_____	_____	_____	_____	_____
_____	_____	_____	_____	_____	_____	_____	_____	_____

¹Type: C= Concentration, D=Depletion, RM=Reduced Matrix, CS=Covered or Coated Sand Grains. ²Location: PL=Pore Lining, M=Matrix

Hydric Soil Indicators: (Applicable to all LRRs, unless otherwise noted.)		Indicators for Problematic Hydric Soils ³ :	
<input type="checkbox"/> Histosol (A1)	<input type="checkbox"/> Sandy Redox (S5)	<input type="checkbox"/> 2 cm Muck (A10)	
<input type="checkbox"/> Histic Epipedon (A2)	<input type="checkbox"/> Stripped Matrix (S6)	<input type="checkbox"/> Red Parent Material (TF2)	
<input type="checkbox"/> Black Histic (A3)	<input type="checkbox"/> Loamy Mucky Mineral (F1) (except MLRA 1)	<input type="checkbox"/> Very Shallow Dark Surface (TF12)	
<input type="checkbox"/> Hydrogen Sulfide (A4)	<input type="checkbox"/> Loamy Gleyed Matrix (F2)	<input type="checkbox"/> Other (Explain in Remarks)	
<input type="checkbox"/> Depleted Below Dark Surface (A11)	<input type="checkbox"/> Depleted Matrix (F3)		
<input type="checkbox"/> Thick Dark Surface (A12)	<input type="checkbox"/> Redox Dark Surface (F6)		
<input type="checkbox"/> Sandy Mucky Mineral (S1)	<input type="checkbox"/> Depleted Dark Surface (F7)		
<input type="checkbox"/> Sandy Gleyed Matrix (S4)	<input type="checkbox"/> Redox Depressions (F8)		

³Indicators of hydrophytic vegetation and wetland hydrology must be present, unless disturbed or problematic.

Restrictive Layer (if present):		Hydric Soils Present?	
Type:	<u>Fill prism</u>	Yes	<input type="checkbox"/>
Depth (inches):	<u>below 4 inches</u>	No	<input checked="" type="checkbox"/>
Remarks: 4 chroma over fill prism			

HYDROLOGY

Wetland Hydrology Indicators:			
Primary Indicators (minimum of one required; check all that apply)		Secondary Indicators (2 or more required)	
<input type="checkbox"/> Surface Water (A1)	<input type="checkbox"/> Water-Stained Leaves (B9)	<input type="checkbox"/> Water-Stained Leaves (B9)	
<input type="checkbox"/> High Water Table (A2)	(except MLRA 1, 2, 4A, and 4B)	(MLRA 1, 2, 4A, and 4B)	
<input type="checkbox"/> Saturation (A3)	<input type="checkbox"/> Salt Crust (B11)	<input type="checkbox"/> Drainage Patterns (B10)	
<input type="checkbox"/> Water Marks (B1)	<input type="checkbox"/> Aquatic Invertebrates (B13)	<input type="checkbox"/> Dry-Season Water Table (C2)	
<input type="checkbox"/> Sediment Deposits (B2)	<input type="checkbox"/> Hydrogen Sulfide Odor (C1)	<input type="checkbox"/> Saturation Visible on Aerial Imagery (C9)	
<input type="checkbox"/> Drift Deposits (B3)	<input type="checkbox"/> Oxidized Rhizospheres along Living Roots (C3)	<input type="checkbox"/> Geomorphic Position (D2)	
<input type="checkbox"/> Algal Mat or Crust (B4)	<input type="checkbox"/> Presence of Reduced Iron (C4)	<input type="checkbox"/> Shallow Aquitard (D3)	
<input type="checkbox"/> Iron Deposits (B5)	<input type="checkbox"/> Recent Iron Reduction in Tilled Soils (C6)	<input type="checkbox"/> FAC-Neutral Test (D5)	
<input type="checkbox"/> Surface Soil Cracks (B6)	<input type="checkbox"/> Stunted or Stresses Plants (D1) (LRR A)	<input type="checkbox"/> Raised Ant Mounds (D6) (LRR A)	
<input type="checkbox"/> Inundation Visible on Aerial Imagery (B7)	<input type="checkbox"/> Other (Explain in Remarks)	<input type="checkbox"/> Frost-Heave Hummocks (D7)	
<input type="checkbox"/> Sparsely Vegetated Concave Surface (B8)			

Field Observations:			
Surface Water Present?	Yes <input type="checkbox"/> No <input checked="" type="checkbox"/>	Depth (inches):	_____
Water Table Present?	Yes <input type="checkbox"/> No <input checked="" type="checkbox"/>	Depth (inches):	_____
Saturation Present? (includes capillary fringe)	Yes <input type="checkbox"/> No <input checked="" type="checkbox"/>	Depth (inches):	_____
		Wetland Hydrology Present?	Yes <input type="checkbox"/> No <input checked="" type="checkbox"/>

Describe Recorded Data (stream gauge, monitoring well, aerial photos, previous inspections), if available:

Remarks: No saturation or water table observed in sample plot

WETLAND DETERMINATION DATA FORM – Western Mountains, Valleys, and Coast Region

Project Site: Sound Transit East Link Extension Project City/County: Bellevue/King Sampling Date: April 23, 2013
 Applicant/Owner: Sound Transit State: WA Sampling Point: Valley Creek SP3W
 Investigator(s): C Douglas & J. Pursley Section, Township, Range: S28, T24N, R5E
 Landform (hillslope, terrace, etc.): Narrow area between development Local relief (concave, convex, none): concave Slope (%): 0% to 2%
 Subregion (LRR): A Lat: 47.62N Long: 122.15W Datum: _____
 Soil Map Unit Name: Bellingham silt loam NWI classification: None Mapped
 Are climatic / hydrologic conditions on the site typical for this time of year? Yes No (If no, explain in Remarks.)
 Are Vegetation , Soil , or Hydrology , significantly disturbed? Are "Normal Circumstances" present? Yes No
 Are Vegetation , Soil , or Hydrology , naturally problematic? (If needed, explain any answers in Remarks.)

SUMMARY OF FINDINGS – Attach site map showing sampling point locations, transects, important features, etc.

Hydrophytic Vegetation Present?	Yes <input checked="" type="checkbox"/>	No <input type="checkbox"/>	Is the Sampled Area within a Wetland?	Yes <input checked="" type="checkbox"/>	No <input type="checkbox"/>
Hydric Soil Present?	Yes <input checked="" type="checkbox"/>	No <input type="checkbox"/>		Yes <input checked="" type="checkbox"/>	No <input type="checkbox"/>
Wetland Hydrology Present?	Yes <input checked="" type="checkbox"/>	No <input type="checkbox"/>		Yes <input checked="" type="checkbox"/>	No <input type="checkbox"/>
Remarks: Wetland is located in narrow area between commercial development and the SR 520 ROW fill prism. Wetland is a narrow depression associated with Valley Creek with culverts entering wetland in several locations. Wetland includes depressional and riverine HGM classes.					

VEGETATION – Use scientific names of plants

Tree Stratum (Plot size: 30 foot radius)	Absolute % Cover	Dominant Species?	Indicator Status	Dominance Test Worksheet:
1. <u><i>Alnus rubra</i></u>	<u>30</u>	<u>yes</u>	<u>FAC</u>	Number of Dominant Species That Are OBL, FACW, or FAC: <u>4</u> (A) Total Number of Dominant Species Across All Strata: <u>5</u> (B) Percent of Dominant Species That Are OBL, FACW, or FAC: <u>80</u> (A/B)
2. <u><i>Salix lasiandra</i></u>	<u>50</u>	<u>yes</u>	<u>FACW</u>	
3. _____	_____	_____	_____	
4. _____	_____	_____	_____	
50% = <u>1</u> , 20% = <u>1</u>	<u>80</u>	= Total Cover		
Sapling/Shrub Stratum (Plot size: 15 foot radius)				Prevalence Index worksheet: Total % Cover of: _____ Multiply by: _____ OBL species _____ x1 = _____ FACW species _____ x2 = _____ FAC species _____ x3 = _____ FACU species _____ x4 = _____ UPL species _____ x5 = _____ Column Totals: _____ (A) _____ (B) Prevalence Index = B/A = _____
1. <u><i>Rubus armeniacus</i></u>	<u>100</u>	<u>yes</u>	<u>FACU</u>	
2. <u><i>Solanum dulcamara</i></u>	<u>5</u>	<u>no</u>	<u>FAC</u>	
3. <u><i>Spiraea douglasii</i></u>	<u>20</u>	<u>yes</u>	<u>FACW</u>	
4. _____	_____	_____	_____	
5. _____	_____	_____	_____	
50% = <u>0</u> , 20% = <u>2</u>	<u>100</u>	= Total Cover		
Herb Stratum (Plot size: 3 foot radius)				Hydrophytic Vegetation Indicators: <input type="checkbox"/> 1 – Rapid Test for Hydrophytic Vegetation <input checked="" type="checkbox"/> 2 - Dominance Test is >50% <input type="checkbox"/> 3 - Prevalence Index is $\leq 3.0^1$ <input type="checkbox"/> 4 - Morphological Adaptations ¹ (Provide supporting data in Remarks or on a separate sheet) <input type="checkbox"/> 5 - Wetland Non-Vascular Plants ¹ <input type="checkbox"/> Problematic Hydrophytic Vegetation ¹ (Explain) ¹ Indicators of hydric soil and wetland hydrology must be present, unless disturbed or problematic.
1. <u><i>Epilobium watsonii</i></u>	<u>5</u>	<u>no</u>	<u>FACW</u>	
2. <u><i>Equisetum arvense</i></u>	<u>20</u>	<u>no</u>	<u>FAC</u>	
3. <u><i>Phalaris arundinacea</i></u>	<u>100</u>	<u>yes</u>	<u>FACW</u>	
4. _____	_____	_____	_____	
5. _____	_____	_____	_____	
6. _____	_____	_____	_____	
7. _____	_____	_____	_____	
8. _____	_____	_____	_____	
9. _____	_____	_____	_____	
10. _____	_____	_____	_____	
11. _____	_____	_____	_____	
50% = <u>1</u> , 20% = <u>0</u>	<u>100</u>	= Total Cover		
Woody Vine Stratum (Plot size: 3 foot radius)				Hydrophytic Vegetation Present? Yes <input checked="" type="checkbox"/> No <input type="checkbox"/>
1. _____	_____	_____	_____	
2. _____	_____	_____	_____	
50% = _____, 20% = _____	<u>0</u>	= Total Cover		
% Bare Ground in Herb Stratum <u>0</u>				

Remarks: 80% dominant wetland vegetation per the Dominance Test

SOIL

Profile Description: (Describe to the depth needed to document the indicator or confirm the absence of indicators.)								
Depth (inches)	Matrix		Redox Features				Texture	Remarks
	Color (moist)	%	Color (moist)	%	Type ¹	Loc ²		
<u>0 to 7</u>	<u>10YR 3/1</u>	<u>100</u>	<u>None</u>	<u>None</u>	<u>None</u>	<u>None</u>	<u>Loam</u>	
<u>7 to 18+</u>	<u>2.5Y 6/1</u>	<u>95</u>	<u>2.5Y 6/6</u>	<u>5</u>	<u>D</u>	<u>M</u>	<u>Sandy loam</u>	
¹ Type: C= Concentration, D=Depletion, RM=Reduced Matrix, CS=Covered or Coated Sand Grains.			² Location: PL=Pore Lining, M=Matrix					
Hydric Soil Indicators: (Applicable to all LRRs, unless otherwise noted.)						Indicators for Problematic Hydric Soils³:		
<input type="checkbox"/> Histosol (A1)			<input checked="" type="checkbox"/> Sandy Redox (S5)			<input type="checkbox"/> 2 cm Muck (A10)		
<input type="checkbox"/> Histic Epipedon (A2)			<input type="checkbox"/> Stripped Matrix (S6)			<input type="checkbox"/> Red Parent Material (TF2)		
<input type="checkbox"/> Black Histic (A3)			<input type="checkbox"/> Loamy Mucky Mineral (F1) (except MLRA 1)			<input type="checkbox"/> Very Shallow Dark Surface (TF12)		
<input type="checkbox"/> Hydrogen Sulfide (A4)			<input type="checkbox"/> Loamy Gleyed Matrix (F2)			<input type="checkbox"/> Other (Explain in Remarks)		
<input type="checkbox"/> Depleted Below Dark Surface (A11)			<input checked="" type="checkbox"/> Depleted Matrix (F3)			³ Indicators of hydrophytic vegetation and wetland hydrology must be present, unless disturbed or problematic.		
<input checked="" type="checkbox"/> Thick Dark Surface (A12)			<input type="checkbox"/> Redox Dark Surface (F6)					
<input type="checkbox"/> Sandy Mucky Mineral (S1)			<input type="checkbox"/> Depleted Dark Surface (F7)					
<input type="checkbox"/> Sandy Gleyed Matrix (S4)			<input type="checkbox"/> Redox Depressions (F8)					
Restrictive Layer (if present):								
Type: _____								
Depth (inches): _____					Hydric Soils Present? Yes <input checked="" type="checkbox"/> No <input type="checkbox"/>			
Remarks: 1 chroma with redox features								

HYDROLOGY

Wetland Hydrology Indicators:			
Primary Indicators (minimum of one required; check all that apply)		Secondary Indicators (2 or more required)	
<input type="checkbox"/> Surface Water (A1)	<input checked="" type="checkbox"/> Water-Stained Leaves (B9)	<input type="checkbox"/> Water-Stained Leaves (B9)	
<input type="checkbox"/> High Water Table (A2)	(except MLRA 1, 2, 4A, and 4B)	(MLRA 1, 2, 4A, and 4B)	
<input checked="" type="checkbox"/> Saturation (A3)	<input type="checkbox"/> Salt Crust (B11)	<input type="checkbox"/> Drainage Patterns (B10)	
<input checked="" type="checkbox"/> Water Marks (B1)	<input type="checkbox"/> Aquatic Invertebrates (B13)	<input type="checkbox"/> Dry-Season Water Table (C2)	
<input type="checkbox"/> Sediment Deposits (B2)	<input type="checkbox"/> Hydrogen Sulfide Odor (C1)	<input type="checkbox"/> Saturation Visible on Aerial Imagery (C9)	
<input type="checkbox"/> Drift Deposits (B3)	<input type="checkbox"/> Oxidized Rhizospheres along Living Roots (C3)	<input type="checkbox"/> Geomorphic Position (D2)	
<input type="checkbox"/> Algal Mat or Crust (B4)	<input type="checkbox"/> Presence of Reduced Iron (C4)	<input type="checkbox"/> Shallow Aquitard (D3)	
<input type="checkbox"/> Iron Deposits (B5)	<input type="checkbox"/> Recent Iron Reduction in Tilled Soils (C6)	<input type="checkbox"/> FAC-Neutral Test (D5)	
<input type="checkbox"/> Surface Soil Cracks (B6)	<input type="checkbox"/> Stunted or Stresses Plants (D1) (LRR A)	<input type="checkbox"/> Raised Ant Mounds (D6) (LRR A)	
<input type="checkbox"/> Inundation Visible on Aerial Imagery (B7)	<input type="checkbox"/> Other (Explain in Remarks)	<input type="checkbox"/> Frost-Heave Hummocks (D7)	
<input type="checkbox"/> Sparsely Vegetated Concave Surface (B8)			
Field Observations:			
Surface Water Present? Yes <input type="checkbox"/> No <input checked="" type="checkbox"/>	Depth (inches): <u>None</u>	Wetland Hydrology Present? Yes <input checked="" type="checkbox"/> No <input type="checkbox"/>	
Water Table Present? Yes <input type="checkbox"/> No <input checked="" type="checkbox"/>	Depth (inches): <u>None</u>		
Saturation Present? (includes capillary fringe) Yes <input checked="" type="checkbox"/> No <input type="checkbox"/>	Depth (inches): <u>Surface</u>		
Describe Recorded Data (stream gauge, monitoring well, aerial photos, previous inspections), if available:			
Remarks: Saturation at surface and no water table to 18 inches from surface			

WETLAND DETERMINATION DATA FORM – Western Mountains, Valleys, and Coast Region

Project Site: Sound Transit East Link Extension Project City/County: Bellevue/King Sampling Date: April 23, 2013
 Applicant/Owner: Sound Transit State: WA Sampling Point: Valley Creek SP4U
 Investigator(s): C Douglas & J. Pursley Section, Township, Range: S28, T24N, R5E
 Landform (hillslope, terrace, etc.): Narrow area between development Local relief (concave, convex, none): concave Slope (%): 0% to 2%
 Subregion (LRR): A Lat: 47.62N Long: 122.15W Datum: _____
 Soil Map Unit Name: Bellingham silt loam NWI classification: None Mapped
 Are climatic / hydrologic conditions on the site typical for this time of year? Yes No (If no, explain in Remarks.)
 Are Vegetation , Soil , or Hydrology , significantly disturbed? Are "Normal Circumstances" present? Yes No
 Are Vegetation , Soil , or Hydrology , naturally problematic? (If needed, explain any answers in Remarks.)

SUMMARY OF FINDINGS – Attach site map showing sampling point locations, transects, important features, etc.

Hydrophytic Vegetation Present?	Yes <input checked="" type="checkbox"/>	No <input type="checkbox"/>	Is the Sampled Area within a Wetland?		
Hydric Soil Present?	Yes <input type="checkbox"/>	No <input checked="" type="checkbox"/>		Yes <input type="checkbox"/>	No <input checked="" type="checkbox"/>
Wetland Hydrology Present?	Yes <input type="checkbox"/>	No <input checked="" type="checkbox"/>			
Remarks: Wetland is located in narrow area between commercial development and the SR 520 ROW fill prism. Wetland is a narrow depression associated with Valley Creek with culverts entering wetland in several locations. Wetland includes depressional and riverine HGM classes.					

VEGETATION – Use scientific names of plants

Tree Stratum (Plot size: 30 foot radius)	Absolute % Cover	Dominant Species?	Indicator Status	Dominance Test Worksheet:																
1. <u><i>Alnus rubra</i></u>	<u>20</u>	<u>yes</u>	<u>FAC</u>	Number of Dominant Species That Are OBL, FACW, or FAC: <u>2</u> (A) Total Number of Dominant Species Across All Strata: <u>3</u> (B) Percent of Dominant Species That Are OBL, FACW, or FAC: <u>67</u> (A/B)																
2. _____	_____	_____	_____																	
3. _____	_____	_____	_____																	
4. _____	_____	_____	_____																	
50% = <u>1</u> , 20% = <u>0</u>	<u>20</u>	= Total Cover																		
Sapling/Shrub Stratum (Plot size: 15 foot radius)																				
1. <u><i>Rubus armeniacus</i></u>	<u>100</u>	<u>yes</u>	<u>FACU</u>	Prevalence Index worksheet: <table style="width: 100%; border: none;"> <tr> <td style="text-align: right;">Total % Cover of:</td> <td style="text-align: right;">Multiply by:</td> </tr> <tr> <td>OBL species _____</td> <td>x1 = _____</td> </tr> <tr> <td>FACW species _____</td> <td>x2 = _____</td> </tr> <tr> <td>FAC species _____</td> <td>x3 = _____</td> </tr> <tr> <td>FACU species _____</td> <td>x4 = _____</td> </tr> <tr> <td>UPL species _____</td> <td>x5 = _____</td> </tr> <tr> <td>Column Totals: _____ (A)</td> <td>_____ (B)</td> </tr> <tr> <td colspan="2" style="text-align: center;">Prevalence Index = B/A = _____</td> </tr> </table>	Total % Cover of:	Multiply by:	OBL species _____	x1 = _____	FACW species _____	x2 = _____	FAC species _____	x3 = _____	FACU species _____	x4 = _____	UPL species _____	x5 = _____	Column Totals: _____ (A)	_____ (B)	Prevalence Index = B/A = _____	
Total % Cover of:	Multiply by:																			
OBL species _____	x1 = _____																			
FACW species _____	x2 = _____																			
FAC species _____	x3 = _____																			
FACU species _____	x4 = _____																			
UPL species _____	x5 = _____																			
Column Totals: _____ (A)	_____ (B)																			
Prevalence Index = B/A = _____																				
2. _____	_____	_____	_____																	
3. _____	_____	_____	_____																	
4. _____	_____	_____	_____																	
5. _____	_____	_____	_____																	
50% = <u>1</u> , 20% = <u>0</u>	<u>100</u>	= Total Cover																		
Herb Stratum (Plot size: 3 foot radius)																				
1. <u><i>Geranium robertianum</i></u>	<u>1</u>	<u>no</u>	<u>UPL</u>	Hydrophytic Vegetation Indicators: <input type="checkbox"/> 1 – Rapid Test for Hydrophytic Vegetation <input checked="" type="checkbox"/> 2 - Dominance Test is >50% <input type="checkbox"/> 3 - Prevalence Index is $\leq 3.0^1$ <input type="checkbox"/> 4 - Morphological Adaptations ¹ (Provide supporting data in Remarks or on a separate sheet) <input type="checkbox"/> 5 - Wetland Non-Vascular Plants ¹ <input type="checkbox"/> Problematic Hydrophytic Vegetation ¹ (Explain) ¹ Indicators of hydric soil and wetland hydrology must be present, unless disturbed or problematic.																
2. <u><i>Ranunculus repens</i></u>	<u>5</u>	<u>yes</u>	<u>FACW</u>																	
3. _____	_____	_____	_____																	
4. _____	_____	_____	_____																	
5. _____	_____	_____	_____																	
6. _____	_____	_____	_____																	
7. _____	_____	_____	_____																	
8. _____	_____	_____	_____																	
9. _____	_____	_____	_____																	
10. _____	_____	_____	_____																	
11. _____	_____	_____	_____																	
50% = <u>1</u> , 20% = <u>0</u>	<u>6</u>	= Total Cover																		
Woody Vine Stratum (Plot size: 3 foot radius)																				
1. _____	_____	_____	_____	Hydrophytic Vegetation Present?																
2. _____	_____	_____	_____		Yes <input checked="" type="checkbox"/> No <input type="checkbox"/>															
50% = _____, 20% = _____	<u>0</u>	= Total Cover																		
% Bare Ground in Herb Stratum <u>94</u>																				

Remarks: 67% dominant wetland vegetation per the Dominance Test.

SOIL

Profile Description: (Describe to the depth needed to document the indicator or confirm the absence of indicators.)								
Depth (inches)	Matrix		Redox Features				Texture	Remarks
	Color (moist)	%	Color (moist)	%	Type ¹	Loc ²		
<u>0 to 18+</u>	<u>10YR 3/4</u>	<u>100</u>	<u>None</u>	<u>None</u>	<u>None</u>	<u>None</u>	<u>Sandy loam</u>	
¹ Type: C= Concentration, D=Depletion, RM=Reduced Matrix, CS=Covered or Coated Sand Grains. ² Location: PL=Pore Lining, M=Matrix								
Hydric Soil Indicators: (Applicable to all LRRs, unless otherwise noted.)						Indicators for Problematic Hydric Soils³:		
<input type="checkbox"/> Histosol (A1)						<input type="checkbox"/> 2 cm Muck (A10)		
<input type="checkbox"/> Histic Epipedon (A2)						<input type="checkbox"/> Red Parent Material (TF2)		
<input type="checkbox"/> Black Histic (A3)						<input type="checkbox"/> Very Shallow Dark Surface (TF12)		
<input type="checkbox"/> Hydrogen Sulfide (A4)						<input type="checkbox"/> Other (Explain in Remarks)		
<input type="checkbox"/> Depleted Below Dark Surface (A11)						³ Indicators of hydrophytic vegetation and wetland hydrology must be present, unless disturbed or problematic.		
<input type="checkbox"/> Thick Dark Surface (A12)								
<input type="checkbox"/> Sandy Mucky Mineral (S1)								
<input type="checkbox"/> Sandy Gleyed Matrix (S4)								
<input type="checkbox"/> Sandy Redox (S5)								
<input type="checkbox"/> Stripped Matrix (S6)								
<input type="checkbox"/> Loamy Mucky Mineral (F1) (except MLRA 1)								
<input type="checkbox"/> Loamy Gleyed Matrix (F2)								
<input type="checkbox"/> Depleted Matrix (F3)								
<input type="checkbox"/> Redox Dark Surface (F6)								
<input type="checkbox"/> Depleted Dark Surface (F7)								
<input type="checkbox"/> Redox Depressions (F8)								
Restrictive Layer (if present):								
Type: _____								
Depth (inches): _____					Hydric Soils Present? Yes <input type="checkbox"/> No <input checked="" type="checkbox"/>			
Remarks: 4 chroma								

HYDROLOGY

Wetland Hydrology Indicators:			
Primary Indicators (minimum of one required; check all that apply)		Secondary Indicators (2 or more required)	
<input type="checkbox"/> Surface Water (A1)	<input type="checkbox"/> Water-Stained Leaves (B9)	<input type="checkbox"/> Water-Stained Leaves (B9)	
<input type="checkbox"/> High Water Table (A2)	(except MLRA 1, 2, 4A, and 4B)	(MLRA 1, 2, 4A, and 4B)	
<input type="checkbox"/> Saturation (A3)	<input type="checkbox"/> Salt Crust (B11)	<input type="checkbox"/> Drainage Patterns (B10)	
<input type="checkbox"/> Water Marks (B1)	<input type="checkbox"/> Aquatic Invertebrates (B13)	<input type="checkbox"/> Dry-Season Water Table (C2)	
<input type="checkbox"/> Sediment Deposits (B2)	<input type="checkbox"/> Hydrogen Sulfide Odor (C1)	<input type="checkbox"/> Saturation Visible on Aerial Imagery (C9)	
<input type="checkbox"/> Drift Deposits (B3)	<input type="checkbox"/> Oxidized Rhizospheres along Living Roots (C3)	<input type="checkbox"/> Geomorphic Position (D2)	
<input type="checkbox"/> Algal Mat or Crust (B4)	<input type="checkbox"/> Presence of Reduced Iron (C4)	<input type="checkbox"/> Shallow Aquitard (D3)	
<input type="checkbox"/> Iron Deposits (B5)	<input type="checkbox"/> Recent Iron Reduction in Tilled Soils (C6)	<input type="checkbox"/> FAC-Neutral Test (D5)	
<input type="checkbox"/> Surface Soil Cracks (B6)	<input type="checkbox"/> Stunted or Stresses Plants (D1) (LRR A)	<input type="checkbox"/> Raised Ant Mounds (D6) (LRR A)	
<input type="checkbox"/> Inundation Visible on Aerial Imagery (B7)	<input type="checkbox"/> Other (Explain in Remarks)	<input type="checkbox"/> Frost-Heave Hummocks (D7)	
<input type="checkbox"/> Sparsely Vegetated Concave Surface (B8)			
Field Observations:			
Surface Water Present?	Yes <input type="checkbox"/> No <input checked="" type="checkbox"/>	Depth (inches):	_____
Water Table Present?	Yes <input type="checkbox"/> No <input checked="" type="checkbox"/>	Depth (inches):	_____
Saturation Present? (includes capillary fringe)	Yes <input type="checkbox"/> No <input checked="" type="checkbox"/>	Depth (inches):	_____
		Wetland Hydrology Present? Yes <input type="checkbox"/> No <input checked="" type="checkbox"/>	
Describe Recorded Data (stream gauge, monitoring well, aerial photos, previous inspections), if available:			
Remarks: No saturation or water table observed in sample plot			

APPENDIX C

WASHINGTON STATE DEPARTMENT OF ECOLOGY WETLAND RATING FORMS

WETLAND RATING FORM – WESTERN WASHINGTON
 Version 2 – Updated July 2006 to increase accuracy and reproducibility among users
 Updated Oct. 2008 with the new WDFW definitions for priority habitats

Name of wetland (if known): 136th Place

Date of site visit: April 9, 2013

Rated by: C. Douglas & J. Pursley Trained by Ecology? Yes No

Date of training: May 2007

SEC: 28 TOWNSHP: 24N RNGE: 5E

Is S/T/R in Appendix D? Yes No

Map of wetland unit: Figure _____ Estimated size _____

SUMMARY OF RATING

Category based on FUNCTIONS provided by wetland: I II III IV

Category I =	Score > 70
Category II =	Score 51 - 69
Category III =	Score 30 – 50
Category IV =	Score < 30

Score for Water Quality Functions

10

Score for Hydrologic Functions

20

Score for Habitat Functions

10

TOTAL Score for Functions

40

Category based on SPECIAL CHARACTERISTICS of Wetland I II Does not apply

Final Category (choose the “highest” category from above”)

III

Summary of basic information about the wetland unit.

Wetland Unit has Special Characteristics		Wetland HGM Class used for Rating	
Estuarine	<input type="checkbox"/>	Depressional	<input checked="" type="checkbox"/>
Natural Heritage Wetland	<input type="checkbox"/>	Riverine	<input type="checkbox"/>
Bog	<input type="checkbox"/>	Lake-fringe	<input type="checkbox"/>
Mature Forest	<input type="checkbox"/>	Slope	<input type="checkbox"/>
Old Growth Forest	<input type="checkbox"/>	Flats	<input type="checkbox"/>
Coastal Lagoon	<input type="checkbox"/>	Freshwater Tidal	<input type="checkbox"/>
Interdunal	<input type="checkbox"/>		<input type="checkbox"/>
None of the above	<input checked="" type="checkbox"/>	Check if unit has multiple HGM classes present	<input type="checkbox"/>

Does the wetland being rated meet any of the criteria below? If you answer YES to any of the questions below you will need to protect the wetland according to the regulations regarding the special characteristics found in the wetland.

Check List for Wetlands that Need Additional Protection (in addition to the protection recommended for its category)	YES	NO
SP1. <i>Has the wetland unit been documented as a habitat for any Federally listed Threatened or Endangered animal or plant species (T/E species)?</i> For the purposes of this rating system, “documented” means the wetland is on the appropriate state or federal database.	<input type="checkbox"/>	<input checked="" type="checkbox"/>
SP2. <i>Has the wetland unit been documented as habitat for any State listed Threatened or Endangered animal species?</i> For the purposes of this rating system, “documented” means the wetland is on the appropriate state database. Note: Wetlands with State listed plant species are categorized as Category 1 Natural Heritage Wetlands (see p. 19 of data form).	<input type="checkbox"/>	<input checked="" type="checkbox"/>
SP3. <i>Does the wetland unit contain individuals of Priority species listed by the WDFW for the state?</i>	<input type="checkbox"/>	<input checked="" type="checkbox"/>
SP4. <i>Does the wetland unit have a local significance in addition to its functions?</i> For example, the wetland has been identified in the Shoreline Master Program, the Critical Areas Ordinance, or in a local management plan as having special significance.	<input type="checkbox"/>	<input checked="" type="checkbox"/>

To complete the next part of the data sheet you will need to determine the Hydrogeomorphic Class of the wetland being rated.

The hydrogeomorphic classification groups wetlands in to those that function in similar ways. This simplifies the questions needed to answer how well the wetland functions. The Hydrogeomorphic Class of a wetland can be determined using the key below. See p. 24 for more detailed instructions on classifying wetlands.

Classification of Vegetated Wetlands for Western Washington

If the hydrologic criteria listed in each question do not apply to the entire unit being rated, you probably have a unit with multiple HGM classes. In this case, identify which hydrologic criteria in questions 1-7 apply, and go to Question 8.

1. Are the water levels in the entire unit usually controlled by tides (i.e. except during floods)?
 NO – go to 2 YES – the wetland class is **Tidal Fringe**
 If yes, is the salinity of the water during periods of annual low flow below 0.5 ppt (parts per thousand)?
 YES – **Freshwater Tidal Fringe** NO – **Saltwater Tidal Fringe (Estuarine)**
*If your wetland can be classified as a Freshwater Tidal Fringe use the forms for **Riverine** wetlands. If it is a Saltwater Tidal Fringe it is rated as an **Estuarine** wetland. Wetlands that were call estuarine in the first and second editions of the rating system are called Salt Water Tidal Fringe in the Hydrogeomorphic Classification. Estuarine wetlands were categorized separately in the earlier editions, and this separation is being kept in this revision. To maintain consistency between editions, the term “Estuarine” wetland is kept. Please note, however, that the characteristics that define Category I and II estuarine wetlands have changed (see p. _____).*
-
2. The entire wetland unit is flat and precipitation is only source (>90%) of water to it. Groundwater and surface water runoff are NOT sources of water to the unit.
 NO – go to 3 YES – The wetland class is **Flats**
 If your wetland can be classified as a “Flats” wetland, use the form for **Depressional** wetlands.
-
3. Does the entire wetland meet both of the following criteria?
 The vegetated part of the wetland is on the shores of a body of permanent open water (without any vegetation on the surface) where at least 20 acres (8ha) in size;
 At least 30% of the open water area is deeper than 6.6 (2 m)?
 NO – go to 4 YES – The wetland class is **Lake-fringe (Lacustrine Fringe)**
-
4. Does the entire wetland meet all of the following criteria?
 The wetland is on a slope (*slope can be very gradual*).
 The water flows through the wetland in one direction (unidirectional) and usually comes from seeps. It may flow subsurface, as sheetflow, or in a swale without distinct banks.
 The water leaves the wetland **without being impounded**?
 NOTE: *Surface water does not pond in these types of wetlands except occasionally in very small and shallow depressions or behind hummocks (depressions are usually <3 ft diameter and less than 1 foot deep).*
 NO – go to 5 YES – The wetland class is **Slope**
-
5. Does the entire wetland meet all of the following criteria?
 The unit is in a valley or stream channel where it gets inundated by overbank flooding from that stream or river.
 The overbank flooding occurs at least once every two years.
 NOTE: *The riverine unit can contain depressions that are filled with water when the river is not flooding..*
 NO – go to 6 YES – The wetland class is **Riverine**
-
6. Is the entire wetland unit in a topographic depression in which water ponds, or is saturated to the surface, at some time of the year. This means that any outlet, if present is higher than the interior of the wetland.
 NO – go to 7 YES – The wetland class is **Depressional**
-
7. Is the entire wetland located in a very flat area with no obvious depression and no overbank flooding. The unit does not pond surface water more than a few inches. The unit seems to be maintained by high groundwater in the area. The wetland may be ditched, but has no obvious natural outlet.
 No – go to 8 YES – The wetland class is **Depressional**
-
8. Your wetland unit seems to be difficult to classify and probably contains several different HGM classes. For example, seeps at the base of a slope may grade into a riverine floodplain, or a small stream within a depressional wetland has a zone of flooding along its sides. GO BACK AND IDENTIFY WHICH OF THE HYDROLOGIC REGIMES DESCRIBED IN QUESTIONS 1-7 APPLY TO DIFFERENT AREAS IN THE UNIT (make a rough sketch to help you decide). Use the following table to identify the appropriate class to use for the rating system if you have several HGM classes present within your wetland. NOTE: Use this table only if the class that is recommended in the second column represents 10% or more of the total area of the wetland unit being rated. If the area of the class listed in column 2 is less than 10% of the unit, classify the wetland using the class that represents more than 90% of the total area.

HGM Classes within the wetland unit being rated	HGM Class to Use in Rating
Slope + Riverine	Riverine
Slope + Depressional	Depressional
Slope + Lake-fringe	Lake-fringe
Depressional + Riverine along stream within boundary	Depressional
Depressional + Lake-fringe	Depressional
Salt Water Tidal Fringe and any other class of freshwater wetland	Treat as ESTUARINE under wetlands with special characteristics

If you are unable still to determine which of the above criteria apply to your wetland, or you have more than 2 HGM classes within a wetland boundary, classify the wetland as **Depressional** for the rating.

D Depressional and Flat Wetlands		Points
WATER QUALITY FUNCTIONS – Indicators that wetland functions to improve water quality.		(only 1 score per box) (see p.38)
D 1	Does the wetland have the <u>potential</u> to improve water quality?	
D 1.1	Characteristics of surface water flows out of the wetland: • Unit is a depression with no surface water leaving it (no outlet) points = 3 <input type="checkbox"/> • Unit has an intermittently flowing, OR highly constricted, permanently flowing outlet ... points = 2 <input checked="" type="checkbox"/> • Unit has an unconstricted, or slightly constricted, surface outlet (<i>permanently flowing</i>) .. points = 1 <input type="checkbox"/> • Unit is a “flat” depression (Q.7 on key), or in the Flats class, with permanent surface outflow and no obvious natural outlet and/or outlet is a man-made ditch..... points = 1 <input type="checkbox"/> <i>(If ditch is not permanently flowing treat unit as “intermittently flowing”)</i> Provide photo or drawing	Figure <input type="checkbox"/> 2
D 1.2	The soil 2 inches below the surface (or duff layer) is clay or organic (<i>use NRCS definitions</i>) YES points = 4 NO points = 0	0
D 1.3	Characteristics of persistent vegetation (emergent, shrub, and/or forest Cowardin class): • Wetland has persistent, ungrazed vegetation > = 95% of area..... points = 5 <input type="checkbox"/> • Wetland has persistent, ungrazed vegetation > = 1/2 of area..... points = 3 <input type="checkbox"/> • Wetland has persistent, ungrazed vegetation > = 1/10 of area..... points = 1 <input checked="" type="checkbox"/> • Wetland has persistent, ungrazed vegetation < 1/10 of area..... points = 0 <input type="checkbox"/> Map of Cowardin vegetation classes	Figure <input type="checkbox"/> 1
D 1.4	Characteristics of seasonal ponding or inundation: <i>This is the area of the wetland that is ponded for at least 2 months, but dries out sometime during the year. Do not count the area that is permanently ponded. Estimate area as the average condition 5 out of 10 years.</i> • Area seasonally ponded is > 1/2 total area of wetland points = 4 <input type="checkbox"/> • Area seasonally ponded is > 1/4 total area of wetland points = 2 <input checked="" type="checkbox"/> • Area seasonally ponded is < 1/4 total area of wetland points = 0 <input type="checkbox"/> Map of Hydroperiods	Figure <input type="checkbox"/> 0
Total for D 1		<i>Add the points in the boxes above</i> 5
D 2	Does the wetland have the <u>opportunity</u> to improve water quality?	(see p. 44)
Answer YES if you know or believe there are pollutants in groundwater or surface water coming into the wetland that would otherwise reduce water quality in streams, lakes or groundwater downgradient from the wetland? <i>Note which of the following conditions provide the sources of pollutants. A unit may have pollutants coming from several sources, but any single source would qualify as opportunity.</i> <input type="checkbox"/> Grazing in the wetland or within 150 ft <input checked="" type="checkbox"/> Untreated stormwater discharges to wetland <input type="checkbox"/> Tilled fields or orchards within 150 ft. of wetland <input type="checkbox"/> A stream or culvert discharges into wetland that drains developed areas, residential areas, farmed fields, roads, or clear-cut logging <input checked="" type="checkbox"/> Residential, urban areas, golf courses are within 150 ft. of wetland <input type="checkbox"/> Wetland is fed by groundwater high in phosphorus or nitrogen <input type="checkbox"/> Other _____		Multiplier 2
<input checked="" type="checkbox"/> YES multiplier is 2 <input type="checkbox"/> NO multiplier is 1		
◆ TOTAL – Water Quality Functions Multiply the score from D1 by D2; then add score to table on p. 1		10
HYDROLOGIC FUNCTIONS – Indicators that wetland unit functions to reduce flooding and stream degradation.		
D 3	Does the wetland have the <u>potential</u> to reduce flooding and erosion?	(see p.46)
D 3.1	Characteristics of surface water flows out of the wetland unit • Unit is a depression with no surface water leaving it (no outlet) points = 4 <input type="checkbox"/> • Unit has an intermittently flowing, OR highly constricted permanently flowing outlet points = 2 <input checked="" type="checkbox"/> • Unit is a “flat” depression (Q.7 on key) or in the Flats class, with permanent surface outflow and no obvious natural outlet and/or outlet is a man-made ditch..... points = 1 <input type="checkbox"/> <i>(If ditch is not permanently flowing treat unit as “intermittently flowing”)</i> • Unit has an unconstricted, or slightly constricted, surface outlet (<i>permanently flowing</i>) points = 0	2
D 3.2	Depth of storage during wet periods. <i>Estimate the height of ponding above the bottom of the outlet. For units with no outlet measure from the surface of permanent water or deepest part (if dry).</i> • Marks of ponding are 3 ft. or more above the surface or bottom of the outlet points = 7 <input type="checkbox"/> • The wetland is a “headwater” wetland..... points = 5 <input type="checkbox"/> • Marks of ponding between 2 ft. to < 3 ft. from surface or bottom of outlet..... points = 5 <input type="checkbox"/> • Marks are at least 0.5 ft. to < 2 ft. from surface or bottom of outlet..... points = 3 <input checked="" type="checkbox"/> • Wetland is flat (yes to Q.2 or Q.7 on key) but has small depressions on the surface that trap water . points = 1 <input type="checkbox"/> • Marks of ponding less than 0.5 ft points = 0 <input type="checkbox"/>	3
D 3.3	Contribution of wetland unit to storage in the watershed: <i>Estimate the ratio of the area of upstream basin contributing surface water to the wetland to the area of the wetland unit itself.</i> • The area of the basin is less than 10 times the area of unit..... points = 5 <input checked="" type="checkbox"/> • The area of the basin is 10 to 100 times the area of the unit..... points = 3 <input type="checkbox"/> • The area of the basin is more than 100 times the area of the unit points = 0 <input type="checkbox"/> • Entire unit is in the FLATS class points = 5 <input type="checkbox"/>	5
Total for D 3		<i>Add the points in the boxes above</i> 10

D 4	<p>Does the wetland have the <u>opportunity</u> to reduce flooding and erosion?</p> <p>Answer YES if the unit is in a location in the watershed where the flood storage, or reduction in water velocity, it provides helps protect downstream property and aquatic resources from flooding or excessive and/or erosive flows. Answer NO if the water coming into the wetland is controlled by a structure such as flood gate, tide gate, flap valve, reservoir etc. OR you estimate that more than 90% of the water in the wetland is from groundwater in areas where damaging groundwater flooding does not occur. <i>Note which of the following indicators of opportunity apply.</i></p> <p><input type="checkbox"/> Wetland is in a headwater of a river or stream that has flooding problems.</p> <p><input checked="" type="checkbox"/> Wetland drains to a river or stream that has flooding problems</p> <p><input type="checkbox"/> Wetland has no outlet and impounds surface runoff water that might otherwise flow into a river or stream that has flooding problems</p> <p><input type="checkbox"/> Other _____</p> <p><input checked="" type="checkbox"/> YES multiplier is 2 <input type="checkbox"/> NO multiplier is 1</p>	<p>(see p. 49)</p> <p>Multiplier</p> <p>2</p>
◆	<p>TOTAL – Hydrologic Functions Multiply the score from D3 by D4; then <i>add score to table on p. 1</i></p>	<p><u>20</u></p>

Comments: _____

These questions apply to wetlands of all HGM classes.		Points																
HABITAT FUNCTIONS – Indicators that wetland functions to provide important habitat.		(only 1 score per box)																
H 1	Does the wetland have the potential to provide habitat for many species?																	
H 1.1	<p>Vegetation structure (see P. 72): Check the types of vegetation classes present (as defined by Cowardin) – Size threshold for each class is 1/4 acre or more than 10% of the area if unit is smaller than 2.5 acres.</p> <p><input type="checkbox"/> Aquatic Bed <input checked="" type="checkbox"/> Emergent plants <input checked="" type="checkbox"/> Scrub/shrub (areas where shrubs have > 30% cover) <input checked="" type="checkbox"/> Forested (areas where trees have > 30% cover)</p> <p>If the unit has a forested class check if: <input type="checkbox"/> The forested class has 3 out of 5 strata (canopy, sub-canopy, shrubs, herbaceous, moss/ground-cover) that each cover 20% within the forested polygon.</p> <p>Add the number of vegetation types that qualify. If you have:</p> <table style="width: 100%; border: none;"> <tr> <td style="width: 50%;">4 structures or more..... points = 4</td> <td style="width: 50%; text-align: right;">Map of Cowardin vegetation classes</td> </tr> <tr> <td>2 structures..... points = 1</td> <td style="text-align: right;">3 structures..... points = 2</td> </tr> <tr> <td></td> <td style="text-align: right;">1 structure..... points = 0</td> </tr> </table>	4 structures or more..... points = 4	Map of Cowardin vegetation classes	2 structures..... points = 1	3 structures..... points = 2		1 structure..... points = 0	<p>Figure <input type="checkbox"/></p> <p style="text-align: right;">2</p>										
4 structures or more..... points = 4	Map of Cowardin vegetation classes																	
2 structures..... points = 1	3 structures..... points = 2																	
	1 structure..... points = 0																	
H 1.2	<p>Hydroperiods (see p.73): Check the types of water regimes (hydroperiods) present within the wetland. The water regime has to cover more than 10% of the wetland or 1/4 acre to count (see text for descriptions of hydroperiods).</p> <table style="width: 100%; border: none;"> <tr> <td style="width: 50%;"><input type="checkbox"/> Permanently flooded or inundated</td> <td style="width: 50%;">4 or more types present</td> <td style="width: 10%;">points = 3</td> <td style="width: 10%;"><input type="checkbox"/></td> </tr> <tr> <td><input checked="" type="checkbox"/> Seasonally flooded or inundated</td> <td>3 or more types present</td> <td>points = 2</td> <td><input type="checkbox"/></td> </tr> <tr> <td><input checked="" type="checkbox"/> Occasionally flooded or inundated</td> <td>2 types present</td> <td>points = 1</td> <td><input checked="" type="checkbox"/></td> </tr> <tr> <td><input checked="" type="checkbox"/> Saturated only</td> <td>1 type present</td> <td>points = 0</td> <td><input type="checkbox"/></td> </tr> </table> <p><input type="checkbox"/> Permanently flowing stream or river in, or adjacent to, the wetland <input type="checkbox"/> Seasonally flowing stream in, or adjacent to, the wetland</p> <p><input type="checkbox"/> Lake-fringe wetland..... = 2 points <input type="checkbox"/> Freshwater tidal wetland..... = 2 points</p> <p style="text-align: right;">Map of hydroperiods</p>	<input type="checkbox"/> Permanently flooded or inundated	4 or more types present	points = 3	<input type="checkbox"/>	<input checked="" type="checkbox"/> Seasonally flooded or inundated	3 or more types present	points = 2	<input type="checkbox"/>	<input checked="" type="checkbox"/> Occasionally flooded or inundated	2 types present	points = 1	<input checked="" type="checkbox"/>	<input checked="" type="checkbox"/> Saturated only	1 type present	points = 0	<input type="checkbox"/>	<p>Figure <input type="checkbox"/></p> <p style="text-align: right;">1</p>
<input type="checkbox"/> Permanently flooded or inundated	4 or more types present	points = 3	<input type="checkbox"/>															
<input checked="" type="checkbox"/> Seasonally flooded or inundated	3 or more types present	points = 2	<input type="checkbox"/>															
<input checked="" type="checkbox"/> Occasionally flooded or inundated	2 types present	points = 1	<input checked="" type="checkbox"/>															
<input checked="" type="checkbox"/> Saturated only	1 type present	points = 0	<input type="checkbox"/>															
H 1.3	<p>Richness of Plant Species (see p. 75): Count the number of plant species in the wetland that cover at least 10 ft² (different patches of the same species can be combined to meet the size threshold) You do not have to name the species. Do not include Eurasian Milfoil, reed canarygrass, purple loosestrife, Canadian Thistle.</p> <p>If you counted:</p> <table style="width: 100%; border: none;"> <tr> <td style="width: 50%;">> 19 species..... points = 2</td> <td style="width: 50%;"><input type="checkbox"/></td> </tr> <tr> <td>5 – 19 species..... points = 1</td> <td><input checked="" type="checkbox"/></td> </tr> <tr> <td>< 5 species..... points = 0</td> <td><input type="checkbox"/></td> </tr> </table> <p>List species below if you want to: _____</p>	> 19 species..... points = 2	<input type="checkbox"/>	5 – 19 species..... points = 1	<input checked="" type="checkbox"/>	< 5 species..... points = 0	<input type="checkbox"/>	<p style="text-align: right;">1</p>										
> 19 species..... points = 2	<input type="checkbox"/>																	
5 – 19 species..... points = 1	<input checked="" type="checkbox"/>																	
< 5 species..... points = 0	<input type="checkbox"/>																	
H 1.4	<p>Interspersion of Habitats (see p. 76): Decided from the diagrams below whether interspersion between Cowardin vegetation (described in H1.1), or the classes and unvegetated areas (can include open water or mudflats) is high, medium, low, or none.</p> <div style="text-align: center;"> <p>None = 0 points Low = 1 point Moderate = 2 points</p> <p>High = 3 points [riparian braided channels]</p> </div> <p>Note: If you have 4 or more classes or 3 vegetation classes and open water, the rating is always “high”.</p> <p style="text-align: right;">Use map of Cowardin classes.</p>	<p>Figure <input type="checkbox"/></p> <p style="text-align: right;">2</p>																
H 1.5	<p>Special Habitat Features (see p. 77): Check the habitat features that are present in the wetland. The number of checks is the number of points you put into the next column.</p> <p><input type="checkbox"/> Large, downed, woody debris within the wetland (> 4 in. diameter and 6 ft. long) <input type="checkbox"/> Standing snags (diameter at the bottom > 4 inches) in the wetland <input type="checkbox"/> Undercut banks are present for at least 6.6 ft. (2m) and/or overhanging vegetation extends at least 3.3 ft. (1m) over a stream (or ditch) in, or contiguous with the unit, for at least 33 ft. (10m) <input type="checkbox"/> Stable steep banks of fine material that might be used by beaver or muskrat for denning (> 30 degree slope) OR signs of recent beaver activity are present (cut shrubs or trees that have not yet turned grey/brown) <input type="checkbox"/> At least 1/4 acre of thin-stemmed persistent vegetation or woody branches are present in areas that are permanently or seasonally inundated (structures for egg-laying by amphibians) <input type="checkbox"/> Invasive plants cover less than 25% of the wetland area in each stratum of plants</p> <p>NOTE: The 20% stated in early printings of the manual on page 78 is an error.</p>	<p style="text-align: right;">0</p>																
H 1 TOTAL Score – potential for providing habitat		Add the points in the column above																
		6																

H 2	Does the wetland have the <u>opportunity</u> to provide habitat for many species?	(only 1 score per box)
	<p>H 2.1 <u>Buffers</u> (see P. 80): Choose the description that best represents condition of buffer of wetland unit. The highest scoring criterion that applies to the wetland is to be used in the rating. See text for definition of "undisturbed".</p> <p><input type="checkbox"/> 100m (330 ft) of relatively undisturbed vegetated areas, rocky areas, or open water > 95% of circumference. No structures are within the undisturbed part of buffer (relatively undisturbed also means no grazing, no landscaping, no daily human use)..... points = 5</p> <p><input type="checkbox"/> 100m (330 ft) of relatively undisturbed vegetated areas, rocky areas, or open water > 50% circumference points = 4</p> <p><input type="checkbox"/> 50m (170 ft) of relatively undisturbed vegetated areas, rocky areas, or open water > 95% circumference points = 4</p> <p><input type="checkbox"/> 100m (330 ft) of relatively undisturbed vegetated areas, rocky areas, or open water > 25% circumference points = 3</p> <p><input type="checkbox"/> 50m (170 ft) of relatively undisturbed vegetated areas, rocky areas, or open water for > 50% circumference points = 3</p> <p>If buffer does not meet any of the criteria above:</p> <p><input type="checkbox"/> No paved areas (except paved trails) or buildings within 25m (80 ft) of wetland > 95% circumference. Light to moderate grazing or lawns are OK points = 2</p> <p><input type="checkbox"/> No paved areas of buildings within 50m of wetland for > 50% circumference. Light to moderate grazing or lawns are OK points = 2</p> <p><input type="checkbox"/> Heavy grazing in buffer points = 1</p> <p><input type="checkbox"/> Vegetated buffers are < 2m wide (6.6 ft) for more than 95% circumference (e.g. tilled fields, paving, basalt bedrock extend to edge of wetland) points = 0</p> <p><input checked="" type="checkbox"/> Buffer does not meet any of the criteria above points = 1</p> <p style="text-align: right;">Arial photo showing buffers</p>	<p>Figure <input type="checkbox"/></p> <p style="text-align: right;">1</p>
	<p>H 2.2 <u>Corridors and Connections</u> (see p. 81)</p> <p>H 2.2.1 Is the wetland part of a relatively undisturbed and unbroken vegetated corridor (either riparian or upland) that is at least 150 ft. wide, has at least a 30% cover of shrubs, forest or native undisturbed prairie, that connects to estuaries, other wetlands or undisturbed uplands that are at least 250 acres in size? (<i>Dams in riparian corridors, heavily used gravel roads, paved roads, are considered breaks in the corridor.</i>)</p> <p style="padding-left: 40px;"><input type="checkbox"/> YES = 4 points (go to H 2.3) <input checked="" type="checkbox"/> NO = go to H 2.2.2</p> <p>H. 2.2.2 Is the wetland part of a relatively undisturbed and unbroken vegetated corridor (either riparian or upland) that is at least 50 ft. wide, has at least 30% cover of shrubs or forest, and connects to estuaries, other wetlands or undisturbed uplands that are at least 25 acres in size? OR a Lake-fringe wetland, if it does not have an undisturbed corridor as in the question above?</p> <p style="padding-left: 40px;"><input type="checkbox"/> YES = 2 points (go to H 2.3) <input checked="" type="checkbox"/> NO = go to H 2.2.3</p> <p>H. 2.2.3 Is the wetland:</p> <ul style="list-style-type: none"> • Within 5 mi (8km) of a brackish or salt water estuary OR • Within 3 miles of a large field or pasture (> 40 acres) OR • Within 1 mile of a lake greater than 20 acres? <p style="text-align: right; padding-right: 40px;"><input type="checkbox"/> YES = 1 point <input checked="" type="checkbox"/> NO = 0 points</p>	<p style="text-align: right;">0</p>

Comments: _____

	<p>H 2.3 <u>Near or adjacent to other priority habitats listed by WDFW</u> (see p. 82): <i>(see new and complete descriptions of WDFW priority habitats, and the counties in which they can be found, in the PHS report http://wdfw.wa.gov/hab/phslist.htm)</i></p> <p>Which of the following priority habitats are within 330 ft. (100m) of the wetland unit? <i>NOTE: the connections do not have to be relatively undisturbed.</i></p> <p><input type="checkbox"/> Aspen Stands: Pure or mixed stands of aspen greater than 0.4 ha (1 acre).</p> <p><input type="checkbox"/> Biodiversity Areas and Corridors: Areas of habitat that are relatively important to various species of native fish and wildlife <i>(full descriptions in WDFW PHS report p. 152).</i></p> <p><input type="checkbox"/> Herbaceous Balds: Variable size patches of grass and forbs on shallow soils over bedrock.</p> <p><input type="checkbox"/> Old-growth/Mature forests: (Old-growth west of Cascade crest) Stands of at least 2 tree species, forming a multi-layered canopy with occasional small openings; with at least 20 trees/ha (8 trees/acre) > 81 cm (32 in) dbh or > 200 years of age. (Mature forests) Stands with average diameters exceeding 53 cm (21 in) dbh; crown cover may be less than 100%; decay, decadence, numbers of snags, and quantity of large downed material is generally less than that found in old-growth; 80 - 200 years old west of the Cascade crest.</p> <p><input type="checkbox"/> Oregon white Oak: Woodlands Stands of pure oak or oak/conifer associations where canopy coverage of the oak component is important <i>(full descriptions in WDFW PHS report p. 158).</i></p> <p><input type="checkbox"/> Riparian: The area adjacent to aquatic systems with flowing water that contains elements of both aquatic and terrestrial ecosystems which mutually influence each other.</p> <p><input type="checkbox"/> Westside Prairies: Herbaceous, non-forested plant communities that can either take the form of a dry prairie or a wet prairie <i>(full descriptions in WDFW PHS report p. 161).</i></p> <p><input type="checkbox"/> Instream: The combination of physical, biological, and chemical processes and conditions that interact to provide functional life history requirements for instream fish and wildlife resources.</p> <p><input type="checkbox"/> Nearshore: Relatively undisturbed nearshore habitats. These include Coastal Nearshore, Open Coast Nearshore, and Puget Sound Nearshore. <i>(full descriptions of habitats and the definition of relatively undisturbed are in WDFW report: pp. 167-169 and glossary in Appendix A).</i></p> <p><input type="checkbox"/> Caves: A naturally occurring cavity, recess, void, or system of interconnected passages under the earth in soils, rock, ice, or other geological formations and is large enough to contain a human.</p> <p><input type="checkbox"/> Cliffs: Greater than 7.6 m (25 ft) high and occurring below 5000 ft.</p> <p><input type="checkbox"/> Talus: Homogenous areas of rock rubble ranging in average size 0.15 - 2.0 m (0.5 - 6.5 ft), composed of basalt, andesite, and/or sedimentary rock, including riprap slides and mine tailings. May be associated with cliffs.</p> <p><input type="checkbox"/> Snags and Logs: Trees are considered snags if they are dead or dying and exhibit sufficient decay characteristics to enable cavity excavation/use by wildlife. Priority snags have a diameter at breast height of > 51 cm (20 in) in western Washington and are > 2 m (6.5 ft) in height. Priority logs are > 30 cm (12 in) in diameter at the largest end, and > 6 m (20 ft) long.</p> <p style="text-align: right;">If wetland has 3 or more priority habitats = 4 points If wetland has 2 priority habitats = 3 points If wetland has 1 priority habitat = 1 point No habitats = 0 points</p> <p>Note: All vegetated wetlands are by definition a priority habitat but are not included in this list. Nearby wetlands are addressed in question H 2.4)</p>	0
	<p>H 2.4 <u>Wetland Landscape:</u> <i>Choose the one description of the landscape around the wetland that best fits (see p. 84)</i></p> <ul style="list-style-type: none"> • There are at least 3 other wetlands within 1/2 mile, and the connections between them are relatively undisturbed (light grazing between wetlands OK, as is lake shore with some boating, but connections should NOT be bisected by paved roads, fill, fields, or other development.... points = 5 <input type="checkbox"/> • The wetland is Lake-fringe on a lake with little disturbance and there are 3 other lake-fringe wetlands within 1/2 mile points = 5 <input type="checkbox"/> • There are at least 3 other wetlands within 1/2 mile, BUT the connections between them are disturbed. points = 3 <input checked="" type="checkbox"/> • The wetland fringe on a lake with disturbance and there are 3 other lake-fringe wetlands within 1/2 mile points = 3 <input type="checkbox"/> • There is at least 1 wetland within 1/2 mile points = 2 <input type="checkbox"/> • There are no wetlands within 1/2 mile..... points = 0 <input type="checkbox"/> 	3
	<p>H 2 TOTAL Score – opportunity for providing habitat <i>Add the scores from H2.1, H2.2, H2.3, H2.4</i></p>	4
	<p><i>TOTAL for H 1 from page 8</i></p>	6
◆	<p>Total Score for Habitat Functions Add the points for H 1 and H 2; then record the result on p. 1</p>	10

Comments: _____

CATEGORIZATION BASED ON SPECIAL CHARACTERISTICS

Please determine if the wetland meets the attributes described below and circle the appropriate answers and Category.

Wetland Type – Check off any criteria that apply to the wetland. Circle the Category when the appropriate criteria are met.	
SC1	<p>Estuarine wetlands? (see p.86)</p> <p>Does the wetland unit meet the following criteria for Estuarine wetlands?</p> <p><input type="checkbox"/> The dominant water regime is tidal, <input type="checkbox"/> Vegetated, and <input type="checkbox"/> With a salinity greater than 0.5 ppt.</p> <p style="text-align: center;"><input type="checkbox"/> YES = Go to SC 1.1 <input checked="" type="checkbox"/> NO</p>
	<p>SC 1.1 Is the wetland unit within a National Wildlife Refuge, National Park, National Estuary Reserve, Natural Area Preserve, State Park or Educational, Environmental, or Scientific Reserve designated under WAC 332-30-151? <input type="checkbox"/> YES = Category I <input type="checkbox"/> NO = go to SC 1.2</p>
	<p>SC 1.2 Is the wetland at least 1 acre in size and meets at least two of the following conditions?</p> <p style="text-align: center;"><input type="checkbox"/> YES = Category I <input type="checkbox"/> NO = Category II</p> <p><input type="checkbox"/> The wetland is relatively undisturbed (has no diking, ditching, filling, cultivation, grazing, and has less than 10% cover of non-native plant species. If the non-native <i>Spartina</i> spp. are only species that cover more than 10% of the wetland, then the wetland should be given a dual rating (I/II). The area of <i>Spartina</i> would be rated a Category II while the relatively undisturbed upper marsh with native species would be a Category I. Do not, however, exclude the area of <i>Spartina</i> in determining the size threshold of 1 acre.</p> <p><input type="checkbox"/> At least 3/4 of the landward edge of the wetland has a 100 ft. buffer of shrub, forest, or un-grazed or un-mowed grassland</p> <p><input type="checkbox"/> The wetland has at least 2 of the following features: tidal channels, depressions with open water, or contiguous freshwater wetlands.</p>
SC2	<p>Natural Heritage Wetlands (see p. 87)</p> <p>Natural Heritage wetlands have been identified by the Washington Natural Heritage Program/DNR as either high quality undisturbed wetlands or wetlands that support state Threatened, Endangered, or Sensitive plant species.</p> <p>SC 2.1 Is the wetland being rated in a Section/Township/Range that contains a natural heritage wetland? (This question is used to screen out most sites before you need to contact WNHP/DNR.)</p> <p style="text-align: center;"><input type="checkbox"/> S/T/R information from Appendix D <input type="checkbox"/> or accessed from WNHP/DNR web site <input type="checkbox"/> YES Contact WNHP/DNR (see p. 79) and go to SC 2.2 <input checked="" type="checkbox"/> NO</p> <p>SC 2.2 Has DNR identified the wetland as a high quality undisturbed wetland or as a site with state threatened or endangered plant species?</p> <p style="text-align: center;"><input type="checkbox"/> YES = Category 1 <input checked="" type="checkbox"/> NO not a Heritage Wetland</p>
SC3	<p>Bogs (see p. 87)</p> <p>Does the wetland (or any part of the unit) meet both the criteria for soils and vegetation in bogs? Use the key below to identify if the wetland is a bog. If you answer yes you will still need to rate the wetland based on its function.</p> <ol style="list-style-type: none"> Does the unit have organic soil horizons (i.e. layers of organic soil), either peats or mucks, that compose 16 inches or more of the first 32 inches of soil profile? (See Appendix B for a field key to identify organic soils)? <input type="checkbox"/> YES = go to question 3 <input checked="" type="checkbox"/> NO = go to question 2 Does the wetland have organic soils, either peats or mucks that are less than 16 inches deep over bedrock, or an impermeable hardpan such as clay or volcanic ash, or that are floating on a lake or pond? <input type="checkbox"/> YES = go to question 3 <input checked="" type="checkbox"/> NO = is not a bog for purpose of rating Does the unit have more than 70% cover of mosses at ground level, AND other plants, if present, consist of the “bog” species listed in Table 3 as a significant component of the vegetation (more than 30% of the total shrub and herbaceous cover consists of species in Table 3)? <p style="text-align: center;"><input type="checkbox"/> YES = Is a bog for purpose of rating <input checked="" type="checkbox"/> NO = go to question 4</p> <p>NOTE: If you are uncertain about the extent of mosses in the understory you may substitute that criterion by measuring the pH of the water that seeps into a hole dug at least 16” deep. If the pH is less than 5.0 and the “bog” plant species in Table 3 are present, the wetland is a bog.</p> <ol style="list-style-type: none"> Is the unit forested (> 30% cover) with sitka spruce, subalpine fir, western red cedar, western hemlock, lodgepole pine, quaking aspen, Englemann’s spruce, or western white pine. WITH any of the species (or combination of species) on the bog species plant list in Table 3 as a significant component of the ground cover (> 30% coverage of the total shrub/herbaceous cover)? <p style="text-align: center;"><input type="checkbox"/> YES = Category I <input checked="" type="checkbox"/> NO = Is not a bog for purpose of rating</p>

SC4	<p>Forested Wetlands (see p. 90)</p> <p>Does the wetland have at least 1 acre of forest that meet one of these criteria for the Department of Fish and Wildlife's forests as priority habitats? <i>If you answer yes you will still need to rate the wetland based on its function.</i></p> <p><input type="checkbox"/> Old-growth forests: (west of Cascade Crest) Stands of at least two three species forming a multi-layered canopy with occasional small openings; with at least 8 trees/acre (20 trees/hectare) that are at least 200 years of age OR have a diameter at breast height (dbh) of 32 inches (81 cm or more). NOTE: The criterion for dbh is based on measurements for upland forests. Two-hundred year old trees in wetlands will often have a smaller dbh because their growth rates are often slower. The DFW criterion is and "OR" so old-growth forests do not necessarily have to have trees of this diameter.</p> <p><input type="checkbox"/> Mature forests: (west of the Cascade Crest) Stands where the largest trees are 80 – 200 years old OR have an average diameters (dbh) exceeding 21 inches (53 cm); crown cover may be less than 100%; decay, decadence, numbers of snags, and quantity of large downed material is generally less than that found in old-growth.</p> <p><input type="checkbox"/> YES = Category I <input checked="" type="checkbox"/> NO = not a forested wetland with special characteristics</p>	<p>Cat. I <input type="checkbox"/></p>
SC5	<p>Wetlands in Coastal Lagoons (see p. 91)</p> <p>Does the wetland meet all of the following criteria of a wetland in a coastal lagoon?</p> <p><input type="checkbox"/> The wetland lies in a depression adjacent to marine waters that is wholly or partially separated from marine waters by sandbanks, gravel banks, shingle, or, less frequently, rocks.</p> <p><input type="checkbox"/> The lagoon in which the wetland is located contains surface water that is saline or brackish (> 0.5 ppt) during most of the year in at least a portion of the lagoon (<i>needs to be measured near the bottom.</i>)</p> <p><input type="checkbox"/> YES = Go to SC 5.1 <input checked="" type="checkbox"/> NO not a wetland in a coastal lagoon</p> <p>SC 5.1 Does the wetland meet all of the following three conditions?</p> <p><input type="checkbox"/> The wetland is relatively undisturbed (has no diking, ditching, filling, cultivation, grazing) and has less than 20% cover of invasive plant species (see list of invasive species on p. 74).</p> <p><input type="checkbox"/> At least 3/4 of the landward edge of the wetland has a 100 ft. buffer of shrub, forest, or un-grazed or un-mowed grassland.</p> <p><input type="checkbox"/> The wetland is larger than 1/10 acre (4350 square ft.)</p> <p><input type="checkbox"/> YES = Category I <input type="checkbox"/> NO = Category II</p>	<p>Cat. I <input type="checkbox"/></p> <p>Cat. II <input type="checkbox"/></p>
SC6	<p>Interdunal Wetlands (see p. 93)</p> <p>Is the wetland west of the 1889 line (also called the Western Boundary of Upland Ownership or WBUO)?</p> <p><input type="checkbox"/> YES = Go to SC 6.1 <input checked="" type="checkbox"/> NO not an interdunal wetland for rating</p> <p><i>If you answer yes you will still need to rate the wetland based on its functions.</i></p> <p>In practical terms that means the following geographic areas:</p> <ul style="list-style-type: none"> • Long Beach Peninsula -- lands west of SR 103 • Grayland-Westport -- lands west of SR 105 • Ocean Shores-Copalis – lands west of SR 115 and SR 109 <p>SC 6.1 Is the wetland one acre or larger, or is it in a mosaic of wetlands that is one acre or larger?</p> <p><input type="checkbox"/> YES = Category II <input type="checkbox"/> NO = go to SC 6.2</p> <p>SC 6.2 Is the wetland between 0.1 and 1 acre, or is it in a mosaic of wetlands that is between 0.1 and 1 acre?</p> <p><input type="checkbox"/> YES = Category III</p>	<p>Cat. II <input type="checkbox"/></p> <p>Cat. III <input type="checkbox"/></p>
◆	<p>Category of wetland based on Special Characteristics</p> <p>Choose the "highest" rating if wetland falls into several categories, and record on p. 1. If you answered NO for all types enter "Not Applicable" on p. 1</p>	<p>NA</p>

Comments:

WETLAND RATING FORM – WESTERN WASHINGTON
 Version 2 – Updated July 2006 to increase accuracy and reproducibility among users
 Updated Oct. 2008 with the new WDFW definitions for priority habitats

Name of wetland (if known): 8th Street

Date of site visit: April 4, 2013

Rated by: C. Douglas & J. Pursley Trained by Ecology? Yes No

Date of training: May 2007

SEC: 5 TOWNSHP: 24N RNGE: 5E

Is S/T/R in Appendix D? Yes No

Map of wetland unit: Figure _____ Estimated size _____

SUMMARY OF RATING

Category based on FUNCTIONS provided by wetland: I II III IV

Category I =	Score > 70
Category II =	Score 51 - 69
Category III =	Score 30 – 50
Category IV =	Score < 30

Score for Water Quality Functions

6

Score for Hydrologic Functions

24

Score for Habitat Functions

11

TOTAL Score for Functions

41

Category based on SPECIAL CHARACTERISTICS of Wetland I II Does not apply

Final Category (choose the “highest” category from above”)

III

Summary of basic information about the wetland unit.

Wetland Unit has Special Characteristics		Wetland HGM Class used for Rating	
Estuarine	<input type="checkbox"/>	Depressional	<input checked="" type="checkbox"/>
Natural Heritage Wetland	<input type="checkbox"/>	Riverine	<input type="checkbox"/>
Bog	<input type="checkbox"/>	Lake-fringe	<input type="checkbox"/>
Mature Forest	<input type="checkbox"/>	Slope	<input type="checkbox"/>
Old Growth Forest	<input type="checkbox"/>	Flats	<input type="checkbox"/>
Coastal Lagoon	<input type="checkbox"/>	Freshwater Tidal	<input type="checkbox"/>
Interdunal	<input type="checkbox"/>		<input type="checkbox"/>
None of the above	<input checked="" type="checkbox"/>	Check if unit has multiple HGM classes present	<input type="checkbox"/>

Does the wetland being rated meet any of the criteria below? If you answer YES to any of the questions below you will need to protect the wetland according to the regulations regarding the special characteristics found in the wetland.

Check List for Wetlands that Need Additional Protection (in addition to the protection recommended for its category)	YES	NO
SP1. <i>Has the wetland unit been documented as a habitat for any Federally listed Threatened or Endangered animal or plant species (T/E species)?</i> For the purposes of this rating system, “documented” means the wetland is on the appropriate state or federal database.	<input type="checkbox"/>	<input checked="" type="checkbox"/>
SP2. <i>Has the wetland unit been documented as habitat for any State listed Threatened or Endangered animal species?</i> For the purposes of this rating system, “documented” means the wetland is on the appropriate state database. Note: Wetlands with State listed plant species are categorized as Category 1 Natural Heritage Wetlands (see p. 19 of data form).	<input type="checkbox"/>	<input checked="" type="checkbox"/>
SP3. <i>Does the wetland unit contain individuals of Priority species listed by the WDFW for the state?</i>	<input type="checkbox"/>	<input checked="" type="checkbox"/>
SP4. <i>Does the wetland unit have a local significance in addition to its functions?</i> For example, the wetland has been identified in the Shoreline Master Program, the Critical Areas Ordinance, or in a local management plan as having special significance.	<input type="checkbox"/>	<input checked="" type="checkbox"/>

To complete the next part of the data sheet you will need to determine the Hydrogeomorphic Class of the wetland being rated.

The hydrogeomorphic classification groups wetlands in to those that function in similar ways. This simplifies the questions needed to answer how well the wetland functions. The Hydrogeomorphic Class of a wetland can be determined using the key below. See p. 24 for more detailed instructions on classifying wetlands.

Classification of Vegetated Wetlands for Western Washington

If the hydrologic criteria listed in each question do not apply to the entire unit being rated, you probably have a unit with multiple HGM classes. In this case, identify which hydrologic criteria in questions 1-7 apply, and go to Question 8.

1. Are the water levels in the entire unit usually controlled by tides (i.e. except during floods)?
 NO – go to 2 YES – the wetland class is **Tidal Fringe**
 If yes, is the salinity of the water during periods of annual low flow below 0.5 ppt (parts per thousand)?
 YES – **Freshwater Tidal Fringe** NO – **Saltwater Tidal Fringe (Estuarine)**
*If your wetland can be classified as a Freshwater Tidal Fringe use the forms for **Riverine** wetlands. If it is a Saltwater Tidal Fringe it is rated as an **Estuarine** wetland. Wetlands that were call estuarine in the first and second editions of the rating system are called Salt Water Tidal Fringe in the Hydrogeomorphic Classification. Estuarine wetlands were categorized separately in the earlier editions, and this separation is being kept in this revision. To maintain consistency between editions, the term “Estuarine” wetland is kept. Please note, however, that the characteristics that define Category I and II estuarine wetlands have changed (see p. _____).*
-
2. The entire wetland unit is flat and precipitation is only source (>90%) of water to it. Groundwater and surface water runoff are NOT sources of water to the unit.
 NO – go to 3 YES – The wetland class is **Flats**
 If your wetland can be classified as a “Flats” wetland, use the form for **Depressional** wetlands.
-
3. Does the entire wetland meet both of the following criteria?
 The vegetated part of the wetland is on the shores of a body of permanent open water (without any vegetation on the surface) where at least 20 acres (8ha) in size;
 At least 30% of the open water area is deeper than 6.6 (2 m)?
 NO – go to 4 YES – The wetland class is **Lake-fringe (Lacustrine Fringe)**
-
4. Does the entire wetland meet all of the following criteria?
 The wetland is on a slope (*slope can be very gradual*).
 The water flows through the wetland in one direction (unidirectional) and usually comes from seeps. It may flow subsurface, as sheetflow, or in a swale without distinct banks.
 The water leaves the wetland **without being impounded**?
 NOTE: *Surface water does not pond in these types of wetlands except occasionally in very small and shallow depressions or behind hummocks (depressions are usually <3 ft diameter and less than 1 foot deep).*
 NO – go to 5 YES – The wetland class is **Slope**
-
5. Does the entire wetland meet all of the following criteria?
 The unit is in a valley or stream channel where it gets inundated by overbank flooding from that stream or river.
 The overbank flooding occurs at least once every two years.
 NOTE: *The riverine unit can contain depressions that are filled with water when the river is not flooding..*
 NO – go to 6 YES – The wetland class is **Riverine**
-
6. Is the entire wetland unit in a topographic depression in which water ponds, or is saturated to the surface, at some time of the year. This means that any outlet, if present is higher than the interior of the wetland.
 NO – go to 7 YES – The wetland class is **Depressional**
-
7. Is the entire wetland located in a very flat area with no obvious depression and no overbank flooding. The unit does not pond surface water more than a few inches. The unit seems to be maintained by high groundwater in the area. The wetland may be ditched, but has no obvious natural outlet.
 No – go to 8 YES – The wetland class is **Depressional**
-
8. Your wetland unit seems to be difficult to classify and probably contains several different HGM classes. For example, seeps at the base of a slope may grade into a riverine floodplain, or a small stream within a depressional wetland has a zone of flooding along its sides. GO BACK AND IDENTIFY WHICH OF THE HYDROLOGIC REGIMES DESCRIBED IN QUESTIONS 1-7 APPLY TO DIFFERENT AREAS IN THE UNIT (make a rough sketch to help you decide). Use the following table to identify the appropriate class to use for the rating system if you have several HGM classes present within your wetland. NOTE: Use this table only if the class that is recommended in the second column represents 10% or more of the total area of the wetland unit being rated. If the area of the class listed in column 2 is less than 10% of the unit, classify the wetland using the class that represents more than 90% of the total area.

HGM Classes within the wetland unit being rated	HGM Class to Use in Rating
Slope + Riverine	Riverine
Slope + Depressional	Depressional
Slope + Lake-fringe	Lake-fringe
Depressional + Riverine along stream within boundary	Depressional
Depressional + Lake-fringe	Depressional
Salt Water Tidal Fringe and any other class of freshwater wetland	Treat as ESTUARINE under wetlands with special characteristics

If you are unable still to determine which of the above criteria apply to your wetland, or you have more than 2 HGM classes within a wetland boundary, classify the wetland as **Depressional** for the rating.

D Depressional and Flat Wetlands		Points
WATER QUALITY FUNCTIONS – Indicators that wetland functions to improve water quality.		(only 1 score per box) (see p.38)
D 1	Does the wetland have the <u>potential</u> to improve water quality?	
D 1.1	Characteristics of surface water flows out of the wetland: • Unit is a depression with no surface water leaving it (no outlet) points = 3 <input type="checkbox"/> • Unit has an intermittently flowing, OR highly constricted, permanently flowing outlet ... points = 2 <input checked="" type="checkbox"/> • Unit has an unconstricted, or slightly constricted, surface outlet (<i>permanently flowing</i>) .. points = 1 <input type="checkbox"/> • Unit is a “flat” depression (Q.7 on key), or in the Flats class, with permanent surface outflow and no obvious natural outlet and/or outlet is a man-made ditch..... points = 1 <input type="checkbox"/> <i>(If ditch is not permanently flowing treat unit as “intermittently flowing”)</i> Provide photo or drawing	Figure <input type="checkbox"/> 2
D 1.2	The soil 2 inches below the surface (or duff layer) is clay or organic (<i>use NRCS definitions</i>) YES points = 4 NO points = 0	0
D 1.3	Characteristics of persistent vegetation (emergent, shrub, and/or forest Cowardin class): • Wetland has persistent, ungrazed vegetation > = 95% of area points = 5 <input type="checkbox"/> • Wetland has persistent, ungrazed vegetation > = 1/2 of area points = 3 <input type="checkbox"/> • Wetland has persistent, ungrazed vegetation > = 1/10 of area points = 1 <input checked="" type="checkbox"/> • Wetland has persistent, ungrazed vegetation < 1/10 of area points = 0 <input type="checkbox"/> Map of Cowardin vegetation classes	Figure <input type="checkbox"/> 1
D 1.4	Characteristics of seasonal ponding or inundation: <i>This is the area of the wetland that is ponded for at least 2 months, but dries out sometime during the year. Do not count the area that is permanently ponded. Estimate area as the average condition 5 out of 10 years.</i> • Area seasonally ponded is > 1/2 total area of wetland points = 4 <input type="checkbox"/> • Area seasonally ponded is > 1/4 total area of wetland points = 2 <input type="checkbox"/> • Area seasonally ponded is < 1/4 total area of wetland points = 0 <input checked="" type="checkbox"/> Map of Hydroperiods	Figure <input type="checkbox"/> 0
Total for D 1		<i>Add the points in the boxes above</i> 3
D 2	Does the wetland have the <u>opportunity</u> to improve water quality?	(see p. 44)
Answer YES if you know or believe there are pollutants in groundwater or surface water coming into the wetland that would otherwise reduce water quality in streams, lakes or groundwater downgradient from the wetland? <i>Note which of the following conditions provide the sources of pollutants. A unit may have pollutants coming from several sources, but any single source would qualify as opportunity.</i> <input type="checkbox"/> Grazing in the wetland or within 150 ft <input checked="" type="checkbox"/> Untreated stormwater discharges to wetland <input type="checkbox"/> Tilled fields or orchards within 150 ft. of wetland <input type="checkbox"/> A stream or culvert discharges into wetland that drains developed areas, residential areas, farmed fields, roads, or clear-cut logging <input checked="" type="checkbox"/> Residential, urban areas, golf courses are within 150 ft. of wetland <input type="checkbox"/> Wetland is fed by groundwater high in phosphorus or nitrogen <input type="checkbox"/> Other _____		Multiplier 2
<input checked="" type="checkbox"/> YES multiplier is 2 <input type="checkbox"/> NO multiplier is 1		
◆ TOTAL – Water Quality Functions Multiply the score from D1 by D2; then add score to table on p. 1		6
HYDROLOGIC FUNCTIONS – Indicators that wetland unit functions to reduce flooding and stream degradation.		
D 3	Does the wetland have the <u>potential</u> to reduce flooding and erosion?	(see p.46)
D 3.1	Characteristics of surface water flows out of the wetland unit • Unit is a depression with no surface water leaving it (no outlet) points = 4 <input type="checkbox"/> • Unit has an intermittently flowing, OR highly constricted permanently flowing outlet points = 2 <input checked="" type="checkbox"/> • Unit is a “flat” depression (Q.7 on key) or in the Flats class, with permanent surface outflow and no obvious natural outlet and/or outlet is a man-made ditch..... points = 1 <input type="checkbox"/> <i>(If ditch is not permanently flowing treat unit as “intermittently flowing”)</i> • Unit has an unconstricted, or slightly constricted, surface outlet (<i>permanently flowing</i>) points = 0	2
D 3.2	Depth of storage during wet periods. <i>Estimate the height of ponding above the bottom of the outlet. For units with no outlet measure from the surface of permanent water or deepest part (if dry).</i> • Marks of ponding are 3 ft. or more above the surface or bottom of the outlet points = 7 <input checked="" type="checkbox"/> • The wetland is a “headwater” wetland..... points = 5 <input type="checkbox"/> • Marks of ponding between 2 ft. to < 3 ft. from surface or bottom of outlet points = 5 <input type="checkbox"/> • Marks are at least 0.5 ft. to < 2 ft. from surface or bottom of outlet points = 3 <input type="checkbox"/> • Wetland is flat (yes to Q.2 or Q.7 on key) but has small depressions on the surface that trap water . points = 1 <input type="checkbox"/> • Marks of ponding less than 0.5 ft points = 0 <input type="checkbox"/>	7
D 3.3	Contribution of wetland unit to storage in the watershed: <i>Estimate the ratio of the area of upstream basin contributing surface water to the wetland to the area of the wetland unit itself.</i> • The area of the basin is less than 10 times the area of unit..... points = 5 <input type="checkbox"/> • The area of the basin is 10 to 100 times the area of the unit..... points = 3 <input checked="" type="checkbox"/> • The area of the basin is more than 100 times the area of the unit points = 0 <input type="checkbox"/> • Entire unit is in the FLATS class points = 5 <input type="checkbox"/>	3
Total for D 3		<i>Add the points in the boxes above</i> 12

D 4	<p>Does the wetland have the <u>opportunity</u> to reduce flooding and erosion?</p> <p>Answer YES if the unit is in a location in the watershed where the flood storage, or reduction in water velocity, it provides helps protect downstream property and aquatic resources from flooding or excessive and/or erosive flows. Answer NO if the water coming into the wetland is controlled by a structure such as flood gate, tide gate, flap valve, reservoir etc. OR you estimate that more than 90% of the water in the wetland is from groundwater in areas where damaging groundwater flooding does not occur. <i>Note which of the following indicators of opportunity apply.</i></p> <p><input type="checkbox"/> Wetland is in a headwater of a river or stream that has flooding problems.</p> <p><input checked="" type="checkbox"/> Wetland drains to a river or stream that has flooding problems</p> <p><input type="checkbox"/> Wetland has no outlet and impounds surface runoff water that might otherwise flow into a river or stream that has flooding problems</p> <p><input type="checkbox"/> Other _____</p> <p><input checked="" type="checkbox"/> YES multiplier is 2 <input type="checkbox"/> NO multiplier is 1</p>	<p>(see p. 49)</p> <p>Multiplier</p> <p>2</p>
◆	<p>TOTAL – Hydrologic Functions Multiply the score from D3 by D4; then <i>add score to table on p. 1</i></p>	<p><u>24</u></p>

Comments: Wetland rated by visual observations from outside property due to lack of ROE.

These questions apply to wetlands of all HGM classes.		Points								
HABITAT FUNCTIONS – Indicators that wetland functions to provide important habitat.		(only 1 score per box)								
H 1	Does the wetland have the potential to provide habitat for many species?									
H 1.1	<p>Vegetation structure (see P. 72): Check the types of vegetation classes present (as defined by Cowardin) – Size threshold for each class is 1/4 acre or more than 10% of the area if unit is smaller than 2.5 acres.</p> <p><input type="checkbox"/> Aquatic Bed <input checked="" type="checkbox"/> Emergent plants <input checked="" type="checkbox"/> Scrub/shrub (areas where shrubs have > 30% cover) <input checked="" type="checkbox"/> Forested (areas where trees have > 30% cover)</p> <p>If the unit has a forested class check if: <input type="checkbox"/> The forested class has 3 out of 5 strata (canopy, sub-canopy, shrubs, herbaceous, moss/ground-cover) that each cover 20% within the forested polygon.</p> <p>Add the number of vegetation types that qualify. If you have:</p> <table style="width: 100%; border: none;"> <tr> <td style="width: 50%;">4 structures or more..... points = 4</td> <td style="width: 50%; text-align: right;">Map of Cowardin vegetation classes</td> </tr> <tr> <td>2 structures..... points = 1</td> <td style="text-align: right;">3 structures..... points = 2</td> </tr> <tr> <td></td> <td style="text-align: right;">1 structure..... points = 0</td> </tr> </table>	4 structures or more..... points = 4	Map of Cowardin vegetation classes	2 structures..... points = 1	3 structures..... points = 2		1 structure..... points = 0	<p>Figure <input type="checkbox"/></p> <p style="text-align: right;">2</p>		
4 structures or more..... points = 4	Map of Cowardin vegetation classes									
2 structures..... points = 1	3 structures..... points = 2									
	1 structure..... points = 0									
H 1.2	<p>Hydroperiods (see p.73): Check the types of water regimes (hydroperiods) present within the wetland. The water regime has to cover more than 10% of the wetland or 1/4 acre to count (see text for descriptions of hydroperiods).</p> <table style="width: 100%; border: none;"> <tr> <td style="width: 50%;"><input type="checkbox"/> Permanently flooded or inundated</td> <td style="width: 50%;">4 or more types present points = 3</td> </tr> <tr> <td><input checked="" type="checkbox"/> Seasonally flooded or inundated</td> <td>3 or more types present points = 2</td> </tr> <tr> <td><input checked="" type="checkbox"/> Occasionally flooded or inundated</td> <td>2 types present points = 1</td> </tr> <tr> <td><input checked="" type="checkbox"/> Saturated only</td> <td>1 type present points = 0</td> </tr> </table> <p><input type="checkbox"/> Permanently flowing stream or river in, or adjacent to, the wetland <input type="checkbox"/> Seasonally flowing stream in, or adjacent to, the wetland</p> <p><input type="checkbox"/> Lake-fringe wetland..... = 2 points <input type="checkbox"/> Freshwater tidal wetland..... = 2 points</p> <p style="text-align: right;">Map of hydroperiods</p>	<input type="checkbox"/> Permanently flooded or inundated	4 or more types present points = 3	<input checked="" type="checkbox"/> Seasonally flooded or inundated	3 or more types present points = 2	<input checked="" type="checkbox"/> Occasionally flooded or inundated	2 types present points = 1	<input checked="" type="checkbox"/> Saturated only	1 type present points = 0	<p>Figure <input type="checkbox"/></p> <p style="text-align: right;">1</p>
<input type="checkbox"/> Permanently flooded or inundated	4 or more types present points = 3									
<input checked="" type="checkbox"/> Seasonally flooded or inundated	3 or more types present points = 2									
<input checked="" type="checkbox"/> Occasionally flooded or inundated	2 types present points = 1									
<input checked="" type="checkbox"/> Saturated only	1 type present points = 0									
H 1.3	<p>Richness of Plant Species (see p. 75): Count the number of plant species in the wetland that cover at least 10 ft² (different patches of the same species can be combined to meet the size threshold) You do not have to name the species. Do not include Eurasian Milfoil, reed canarygrass, purple loosestrife, Canadian Thistle.</p> <p>If you counted:</p> <table style="width: 100%; border: none;"> <tr> <td style="width: 50%;">> 19 species..... points = 2</td> <td style="width: 50%;"><input type="checkbox"/></td> </tr> <tr> <td>5 – 19 species..... points = 1</td> <td><input checked="" type="checkbox"/></td> </tr> <tr> <td>< 5 species..... points = 0</td> <td><input type="checkbox"/></td> </tr> </table> <p>List species below if you want to:</p> <hr style="width: 100px; margin-left: 0;"/>	> 19 species..... points = 2	<input type="checkbox"/>	5 – 19 species..... points = 1	<input checked="" type="checkbox"/>	< 5 species..... points = 0	<input type="checkbox"/>	<p style="text-align: right;">1</p>		
> 19 species..... points = 2	<input type="checkbox"/>									
5 – 19 species..... points = 1	<input checked="" type="checkbox"/>									
< 5 species..... points = 0	<input type="checkbox"/>									
H 1.4	<p>Interspersion of Habitats (see p. 76): Decided from the diagrams below whether interspersion between Cowardin vegetation (described in H1.1), or the classes and unvegetated areas (can include open water or mudflats) is high, medium, low, or none.</p> <div style="text-align: center;"> <p>None = 0 points Low = 1 point Moderate = 2 points</p> <p>High = 3 points [riparian braided channels]</p> </div> <p>Note: If you have 4 or more classes or 3 vegetation classes and open water, the rating is always “high”.</p> <p style="text-align: right;">Use map of Cowardin classes.</p>	<p>Figure <input type="checkbox"/></p> <p style="text-align: right;">2</p>								
H 1.5	<p>Special Habitat Features (see p. 77): Check the habitat features that are present in the wetland. The number of checks is the number of points you put into the next column.</p> <p><input type="checkbox"/> Large, downed, woody debris within the wetland (> 4 in. diameter and 6 ft. long) <input type="checkbox"/> Standing snags (diameter at the bottom > 4 inches) in the wetland <input type="checkbox"/> Undercut banks are present for at least 6.6 ft. (2m) and/or overhanging vegetation extends at least 3.3 ft. (1m) over a stream (or ditch) in, or contiguous with the unit, for at least 33 ft. (10m) <input type="checkbox"/> Stable steep banks of fine material that might be used by beaver or muskrat for denning (> 30 degree slope) OR signs of recent beaver activity are present (cut shrubs or trees that have not yet turned grey/brown) <input type="checkbox"/> At least 1/4 acre of thin-stemmed persistent vegetation or woody branches are present in areas that are permanently or seasonally inundated (structures for egg-laying by amphibians) <input type="checkbox"/> Invasive plants cover less than 25% of the wetland area in each stratum of plants</p> <p>NOTE: The 20% stated in early printings of the manual on page 78 is an error.</p>	<p style="text-align: right;">0</p>								
H 1 TOTAL Score – potential for providing habitat		6								
Add the points in the column above										

H 2	Does the wetland have the <u>opportunity</u> to provide habitat for many species?	(only 1 score per box)
	<p>H 2.1 <u>Buffers</u> (see P. 80): Choose the description that best represents condition of buffer of wetland unit. The highest scoring criterion that applies to the wetland is to be used in the rating. See text for definition of "undisturbed".</p> <p><input type="checkbox"/> 100m (330 ft) of relatively undisturbed vegetated areas, rocky areas, or open water > 95% of circumference. No structures are within the undisturbed part of buffer (relatively undisturbed also means no grazing, no landscaping, no daily human use)..... points = 5</p> <p><input type="checkbox"/> 100m (330 ft) of relatively undisturbed vegetated areas, rocky areas, or open water > 50% circumference points = 4</p> <p><input type="checkbox"/> 50m (170 ft) of relatively undisturbed vegetated areas, rocky areas, or open water > 95% circumference points = 4</p> <p><input type="checkbox"/> 100m (330 ft) of relatively undisturbed vegetated areas, rocky areas, or open water > 25% circumference points = 3</p> <p><input type="checkbox"/> 50m (170 ft) of relatively undisturbed vegetated areas, rocky areas, or open water for > 50% circumference points = 3</p> <p>If buffer does not meet any of the criteria above:</p> <p><input type="checkbox"/> No paved areas (except paved trails) or buildings within 25m (80 ft) of wetland > 95% circumference. Light to moderate grazing or lawns are OK points = 2</p> <p><input type="checkbox"/> No paved areas of buildings within 50m of wetland for > 50% circumference. Light to moderate grazing or lawns are OK points = 2</p> <p><input type="checkbox"/> Heavy grazing in buffer points = 1</p> <p><input type="checkbox"/> Vegetated buffers are < 2m wide (6.6 ft) for more than 95% circumference (e.g. tilled fields, paving, basalt bedrock extend to edge of wetland) points = 0</p> <p><input checked="" type="checkbox"/> Buffer does not meet any of the criteria above points = 1</p> <p style="text-align: right;">Arial photo showing buffers</p>	<p>Figure <input type="checkbox"/></p> <p style="text-align: right;">1</p>
	<p>H 2.2 <u>Corridors and Connections</u> (see p. 81)</p> <p>H 2.2.1 Is the wetland part of a relatively undisturbed and unbroken vegetated corridor (either riparian or upland) that is at least 150 ft. wide, has at least a 30% cover of shrubs, forest or native undisturbed prairie, that connects to estuaries, other wetlands or undisturbed uplands that are at least 250 acres in size? (<i>Dams in riparian corridors, heavily used gravel roads, paved roads, are considered breaks in the corridor.</i>)</p> <p style="padding-left: 40px;"><input type="checkbox"/> YES = 4 points (go to H 2.3) <input checked="" type="checkbox"/> NO = go to H 2.2.2</p> <p>H. 2.2.2 Is the wetland part of a relatively undisturbed and unbroken vegetated corridor (either riparian or upland) that is at least 50 ft. wide, has at least 30% cover of shrubs or forest, and connects to estuaries, other wetlands or undisturbed uplands that are at least 25 acres in size? OR a Lake-fringe wetland, if it does not have an undisturbed corridor as in the question above?</p> <p style="padding-left: 40px;"><input type="checkbox"/> YES = 2 points (go to H 2.3) <input checked="" type="checkbox"/> NO = go to H 2.2.3</p> <p>H. 2.2.3 Is the wetland:</p> <ul style="list-style-type: none"> • Within 5 mi (8km) of a brackish or salt water estuary OR • Within 3 miles of a large field or pasture (> 40 acres) OR • Within 1 mile of a lake greater than 20 acres? <p style="text-align: right; padding-right: 40px;"><input checked="" type="checkbox"/> YES = 1 point <input type="checkbox"/> NO = 0 points</p>	<p style="text-align: right;">1</p>

Comments: Wetland rated by visual observations from outside property due to lack of ROE.

	<p>H 2.3 <u>Near or adjacent to other priority habitats listed by WDFW</u> (see p. 82): (see new and complete descriptions of WDFW priority habitats, and the counties in which they can be found, in the PHS report http://wdfw.wa.gov/hab/phslist.htm) Which of the following priority habitats are within 330 ft. (100m) of the wetland unit? <i>NOTE: the connections do not have to be relatively undisturbed.</i></p> <p><input type="checkbox"/> Aspen Stands: Pure or mixed stands of aspen greater than 0.4 ha (1 acre).</p> <p><input type="checkbox"/> Biodiversity Areas and Corridors: Areas of habitat that are relatively important to various species of native fish and wildlife (full descriptions in WDFW PHS report p. 152).</p> <p><input type="checkbox"/> Herbaceous Balds: Variable size patches of grass and forbs on shallow soils over bedrock.</p> <p><input type="checkbox"/> Old-growth/Mature forests: (Old-growth west of Cascade crest) Stands of at least 2 tree species, forming a multi-layered canopy with occasional small openings; with at least 20 trees/ha (8 trees/acre) > 81 cm (32 in) dbh or > 200 years of age. (Mature forests) Stands with average diameters exceeding 53 cm (21 in) dbh; crown cover may be less than 100%; decay, decadence, numbers of snags, and quantity of large downed material is generally less than that found in old-growth; 80 - 200 years old west of the Cascade crest.</p> <p><input type="checkbox"/> Oregon white Oak: Woodlands Stands of pure oak or oak/conifer associations where canopy coverage of the oak component is important (full descriptions in WDFW PHS report p. 158).</p> <p><input type="checkbox"/> Riparian: The area adjacent to aquatic systems with flowing water that contains elements of both aquatic and terrestrial ecosystems which mutually influence each other.</p> <p><input type="checkbox"/> Westside Prairies: Herbaceous, non-forested plant communities that can either take the form of a dry prairie or a wet prairie (full descriptions in WDFW PHS report p. 161).</p> <p><input type="checkbox"/> Instream: The combination of physical, biological, and chemical processes and conditions that interact to provide functional life history requirements for instream fish and wildlife resources.</p> <p><input type="checkbox"/> Nearshore: Relatively undisturbed nearshore habitats. These include Coastal Nearshore, Open Coast Nearshore, and Puget Sound Nearshore. (full descriptions of habitats and the definition of relatively undisturbed are in WDFW report: pp. 167-169 and glossary in Appendix A).</p> <p><input type="checkbox"/> Caves: A naturally occurring cavity, recess, void, or system of interconnected passages under the earth in soils, rock, ice, or other geological formations and is large enough to contain a human.</p> <p><input type="checkbox"/> Cliffs: Greater than 7.6 m (25 ft) high and occurring below 5000 ft.</p> <p><input type="checkbox"/> Talus: Homogenous areas of rock rubble ranging in average size 0.15 - 2.0 m (0.5 - 6.5 ft), composed of basalt, andesite, and/or sedimentary rock, including riprap slides and mine tailings. May be associated with cliffs.</p> <p><input type="checkbox"/> Snags and Logs: Trees are considered snags if they are dead or dying and exhibit sufficient decay characteristics to enable cavity excavation/use by wildlife. Priority snags have a diameter at breast height of > 51 cm (20 in) in western Washington and are > 2 m (6.5 ft) in height. Priority logs are > 30 cm (12 in) in diameter at the largest end, and > 6 m (20 ft) long.</p> <p style="text-align: right;">If wetland has 3 or more priority habitats = 4 points If wetland has 2 priority habitats = 3 points If wetland has 1 priority habitat = 1 point No habitats = 0 points</p> <p>Note: All vegetated wetlands are by definition a priority habitat but are not included in this list. Nearby wetlands are addressed in question H 2.4)</p>	0
	<p>H 2.4 <u>Wetland Landscape:</u> Choose the one description of the landscape around the wetland that best fits (see p. 84)</p> <ul style="list-style-type: none"> • There are at least 3 other wetlands within 1/2 mile, and the connections between them are relatively undisturbed (light grazing between wetlands OK, as is lake shore with some boating, but connections should NOT be bisected by paved roads, fill, fields, or other development.... points = 5 <input type="checkbox"/> • The wetland is Lake-fringe on a lake with little disturbance and there are 3 other lake-fringe wetlands within 1/2 mile points = 5 <input type="checkbox"/> • There are at least 3 other wetlands within 1/2 mile, BUT the connections between them are disturbed. points = 3 <input checked="" type="checkbox"/> • The wetland fringe on a lake with disturbance and there are 3 other lake-fringe wetlands within 1/2 mile points = 3 <input type="checkbox"/> • There is at least 1 wetland within 1/2 mile points = 2 <input type="checkbox"/> • There are no wetlands within 1/2 mile..... points = 0 <input type="checkbox"/> 	3
	<p>H 2 TOTAL Score – opportunity for providing habitat Add the scores from H2.1, H2.2, H2.3, H2.4</p>	5
	<p style="text-align: right;">TOTAL for H 1 from page 8</p>	6
◆	<p>Total Score for Habitat Functions Add the points for H 1 and H 2; then record the result on p. 1</p>	11

Comments: Wetland rated by visual observations from outside property due to lack of ROE.

CATEGORIZATION BASED ON SPECIAL CHARACTERISTICS

Please determine if the wetland meets the attributes described below and circle the appropriate answers and Category.

Wetland Type – Check off any criteria that apply to the wetland. Circle the Category when the appropriate criteria are met.	
SC1	<p>Estuarine wetlands? (see p.86)</p> <p>Does the wetland unit meet the following criteria for Estuarine wetlands?</p> <p><input type="checkbox"/> The dominant water regime is tidal, <input type="checkbox"/> Vegetated, and <input type="checkbox"/> With a salinity greater than 0.5 ppt.</p> <p style="text-align: center;"><input type="checkbox"/> YES = Go to SC 1.1 <input checked="" type="checkbox"/> NO</p>
	<p>SC 1.1 Is the wetland unit within a National Wildlife Refuge, National Park, National Estuary Reserve, Natural Area Preserve, State Park or Educational, Environmental, or Scientific Reserve designated under WAC 332-30-151? <input type="checkbox"/> YES = Category I <input type="checkbox"/> NO = go to SC 1.2</p>
	<p>SC 1.2 Is the wetland at least 1 acre in size and meets at least two of the following conditions?</p> <p style="text-align: center;"><input type="checkbox"/> YES = Category I <input type="checkbox"/> NO = Category II</p> <p><input type="checkbox"/> The wetland is relatively undisturbed (has no diking, ditching, filling, cultivation, grazing, and has less than 10% cover of non-native plant species. If the non-native <i>Spartina</i> spp. are only species that cover more than 10% of the wetland, then the wetland should be given a dual rating (I/II). The area of <i>Spartina</i> would be rated a Category II while the relatively undisturbed upper marsh with native species would be a Category I. Do not, however, exclude the area of <i>Spartina</i> in determining the size threshold of 1 acre.</p> <p><input type="checkbox"/> At least 3/4 of the landward edge of the wetland has a 100 ft. buffer of shrub, forest, or un-grazed or un-mowed grassland</p> <p><input type="checkbox"/> The wetland has at least 2 of the following features: tidal channels, depressions with open water, or contiguous freshwater wetlands.</p>
SC2	<p>Natural Heritage Wetlands (see p. 87)</p> <p>Natural Heritage wetlands have been identified by the Washington Natural Heritage Program/DNR as either high quality undisturbed wetlands or wetlands that support state Threatened, Endangered, or Sensitive plant species.</p> <p>SC 2.1 Is the wetland being rated in a Section/Township/Range that contains a natural heritage wetland? (This question is used to screen out most sites before you need to contact WNHP/DNR.)</p> <p style="text-align: center;"><input type="checkbox"/> S/T/R information from Appendix D <input type="checkbox"/> or accessed from WNHP/DNR web site <input type="checkbox"/> YES Contact WNHP/DNR (see p. 79) and go to SC 2.2 <input checked="" type="checkbox"/> NO</p> <p>SC 2.2 Has DNR identified the wetland as a high quality undisturbed wetland or as a site with state threatened or endangered plant species?</p> <p style="text-align: center;"><input type="checkbox"/> YES = Category 1 <input checked="" type="checkbox"/> NO not a Heritage Wetland</p>
SC3	<p>Bogs (see p. 87)</p> <p>Does the wetland (or any part of the unit) meet both the criteria for soils and vegetation in bogs? Use the key below to identify if the wetland is a bog. If you answer yes you will still need to rate the wetland based on its function.</p> <ol style="list-style-type: none"> Does the unit have organic soil horizons (i.e. layers of organic soil), either peats or mucks, that compose 16 inches or more of the first 32 inches of soil profile? (See Appendix B for a field key to identify organic soils)? <input type="checkbox"/> YES = go to question 3 <input checked="" type="checkbox"/> NO = go to question 2 Does the wetland have organic soils, either peats or mucks that are less than 16 inches deep over bedrock, or an impermeable hardpan such as clay or volcanic ash, or that are floating on a lake or pond? <input type="checkbox"/> YES = go to question 3 <input checked="" type="checkbox"/> NO = is not a bog for purpose of rating Does the unit have more than 70% cover of mosses at ground level, AND other plants, if present, consist of the “bog” species listed in Table 3 as a significant component of the vegetation (more than 30% of the total shrub and herbaceous cover consists of species in Table 3)? <p style="text-align: center;"><input type="checkbox"/> YES = Is a bog for purpose of rating <input checked="" type="checkbox"/> NO = go to question 4</p> <p>NOTE: If you are uncertain about the extent of mosses in the understory you may substitute that criterion by measuring the pH of the water that seeps into a hole dug at least 16” deep. If the pH is less than 5.0 and the “bog” plant species in Table 3 are present, the wetland is a bog.</p> <ol style="list-style-type: none"> Is the unit forested (> 30% cover) with sitka spruce, subalpine fir, western red cedar, western hemlock, lodgepole pine, quaking aspen, Englemann’s spruce, or western white pine. WITH any of the species (or combination of species) on the bog species plant list in Table 3 as a significant component of the ground cover (> 30% coverage of the total shrub/herbaceous cover)? <p style="text-align: center;"><input type="checkbox"/> YES = Category I <input checked="" type="checkbox"/> NO = Is not a bog for purpose of rating</p>

SC4	<p>Forested Wetlands (see p. 90)</p> <p>Does the wetland have at least 1 acre of forest that meet one of these criteria for the Department of Fish and Wildlife’s forests as priority habitats? <i>If you answer yes you will still need to rate the wetland based on its function.</i></p> <p><input type="checkbox"/> Old-growth forests: (west of Cascade Crest) Stands of at least two three species forming a multi-layered canopy with occasional small openings; with at least 8 trees/acre (20 trees/hectare) that are at least 200 years of age OR have a diameter at breast height (dbh) of 32 inches (81 cm or more). NOTE: The criterion for dbh is based on measurements for upland forests. Two-hundred year old trees in wetlands will often have a smaller dbh because their growth rates are often slower. The DFW criterion is and “OR” so old-growth forests do not necessarily have to have trees of this diameter.</p> <p><input type="checkbox"/> Mature forests: (west of the Cascade Crest) Stands where the largest trees are 80 – 200 years old OR have an average diameters (dbh) exceeding 21 inches (53 cm); crown cover may be less than 100%; decay, decadence, numbers of snags, and quantity of large downed material is generally less than that found in old-growth.</p> <p><input type="checkbox"/> YES = Category I <input checked="" type="checkbox"/> NO = not a forested wetland with special characteristics</p>	<p>Cat. I <input type="checkbox"/></p>
SC5	<p>Wetlands in Coastal Lagoons (see p. 91)</p> <p>Does the wetland meet all of the following criteria of a wetland in a coastal lagoon?</p> <p><input type="checkbox"/> The wetland lies in a depression adjacent to marine waters that is wholly or partially separated from marine waters by sandbanks, gravel banks, shingle, or, less frequently, rocks.</p> <p><input type="checkbox"/> The lagoon in which the wetland is located contains surface water that is saline or brackish (> 0.5 ppt) during most of the year in at least a portion of the lagoon (<i>needs to be measured near the bottom.</i>)</p> <p><input type="checkbox"/> YES = Go to SC 5.1 <input checked="" type="checkbox"/> NO not a wetland in a coastal lagoon</p> <p>SC 5.1 Does the wetland meet all of the following three conditions?</p> <p><input type="checkbox"/> The wetland is relatively undisturbed (has no diking, ditching, filling, cultivation, grazing) and has less than 20% cover of invasive plant species (see list of invasive species on p. 74).</p> <p><input type="checkbox"/> At least 3/4 of the landward edge of the wetland has a 100 ft. buffer of shrub, forest, or un-grazed or un-mowed grassland.</p> <p><input type="checkbox"/> The wetland is larger than 1/10 acre (4350 square ft.)</p> <p><input type="checkbox"/> YES = Category I <input type="checkbox"/> NO = Category II</p>	<p style="background-color: #cccccc;"> </p> <p>Cat. I <input type="checkbox"/></p> <p>Cat. II <input type="checkbox"/></p>
SC6	<p>Interdunal Wetlands (see p. 93)</p> <p>Is the wetland west of the 1889 line (also called the Western Boundary of Upland Ownership or WBUO)?</p> <p><input type="checkbox"/> YES = Go to SC 6.1 <input checked="" type="checkbox"/> NO not an interdunal wetland for rating</p> <p><i>If you answer yes you will still need to rate the wetland based on its functions.</i></p> <p>In practical terms that means the following geographic areas:</p> <ul style="list-style-type: none"> • Long Beach Peninsula -- lands west of SR 103 • Grayland-Westport -- lands west of SR 105 • Ocean Shores-Copalis – lands west of SR 115 and SR 109 <p>SC 6.1 Is the wetland one acre or larger, or is it in a mosaic of wetlands that is one acre or larger?</p> <p><input type="checkbox"/> YES = Category II <input type="checkbox"/> NO = go to SC 6.2</p> <p>SC 6.2 Is the wetland between 0.1 and 1 acre, or is it in a mosaic of wetlands that is between 0.1 and 1 acre?</p> <p><input type="checkbox"/> YES = Category III</p>	<p>Cat. II <input type="checkbox"/></p> <p>Cat. III <input type="checkbox"/></p>
◆	<p>Category of wetland based on Special Characteristics</p> <p><i>Choose the “highest” rating if wetland falls into several categories, and record on p. 1.</i></p> <p>If you answered NO for all types enter “Not Applicable” on p. 1</p>	<p>NA</p>

Comments:

WETLAND RATING FORM – WESTERN WASHINGTON
Version 2 – Updated July 2006 to increase accuracy and reproducibility among users
Updated Oct. 2008 with the new WDFW definitions for priority habitats

Name of wetland (if known): Alcove Creek

Date of site visit: April 4, 2013

Rated by: C. Douglas & J. Pursley Trained by Ecology? Yes No

Date of training: May 2007

SEC: 5 TOWNSHP: 24N RNGE: 5E

Is S/T/R in Appendix D? Yes No

Map of wetland unit: Figure _____ Estimated size _____

SUMMARY OF RATING

Category based on FUNCTIONS provided by wetland: I II III IV

Category I =	Score > 70
Category II =	Score 51 - 69
Category III =	Score 30 – 50
Category IV =	Score < 30

Score for Water Quality Functions	14
Score for Hydrologic Functions	20
Score for Habitat Functions	19
TOTAL Score for Functions	53

Category based on SPECIAL CHARACTERISTICS of Wetland I II Does not apply

Final Category (choose the “highest” category from above”)

II

Summary of basic information about the wetland unit.

Wetland Unit has Special Characteristics		Wetland HGM Class used for Rating	
Estuarine	<input type="checkbox"/>	Depressional	<input checked="" type="checkbox"/>
Natural Heritage Wetland	<input type="checkbox"/>	Riverine	<input checked="" type="checkbox"/>
Bog	<input type="checkbox"/>	Lake-fringe	<input type="checkbox"/>
Mature Forest	<input type="checkbox"/>	Slope	<input type="checkbox"/>
Old Growth Forest	<input type="checkbox"/>	Flats	<input type="checkbox"/>
Coastal Lagoon	<input type="checkbox"/>	Freshwater Tidal	<input type="checkbox"/>
Interdunal	<input type="checkbox"/>		<input type="checkbox"/>
None of the above	<input checked="" type="checkbox"/>	Check if unit has multiple HGM classes present	<input checked="" type="checkbox"/>

Does the wetland being rated meet any of the criteria below? If you answer YES to any of the questions below you will need to protect the wetland according to the regulations regarding the special characteristics found in the wetland.

Check List for Wetlands that Need Additional Protection (in addition to the protection recommended for its category)	YES	NO
SP1. <i>Has the wetland unit been documented as a habitat for any Federally listed Threatened or Endangered animal or plant species (T/E species)?</i> For the purposes of this rating system, “documented” means the wetland is on the appropriate state or federal database.	<input type="checkbox"/>	<input checked="" type="checkbox"/>
SP2. <i>Has the wetland unit been documented as habitat for any State listed Threatened or Endangered animal species?</i> For the purposes of this rating system, “documented” means the wetland is on the appropriate state database. Note: Wetlands with State listed plant species are categorized as Category 1 Natural Heritage Wetlands (see p. 19 of data form).	<input type="checkbox"/>	<input checked="" type="checkbox"/>
SP3. <i>Does the wetland unit contain individuals of Priority species listed by the WDFW for the state?</i>	<input type="checkbox"/>	<input checked="" type="checkbox"/>
SP4. <i>Does the wetland unit have a local significance in addition to its functions?</i> For example, the wetland has been identified in the Shoreline Master Program, the Critical Areas Ordinance, or in a local management plan as having special significance.	<input type="checkbox"/>	<input checked="" type="checkbox"/>

To complete the next part of the data sheet you will need to determine the Hydrogeomorphic Class of the wetland being rated.

The hydrogeomorphic classification groups wetlands in to those that function in similar ways. This simplifies the questions needed to answer how well the wetland functions. The Hydrogeomorphic Class of a wetland can be determined using the key below. See p. 24 for more detailed instructions on classifying wetlands.

Classification of Vegetated Wetlands for Western Washington

If the hydrologic criteria listed in each question do not apply to the entire unit being rated, you probably have a unit with multiple HGM classes. In this case, identify which hydrologic criteria in questions 1-7 apply, and go to Question 8.

1. Are the water levels in the entire unit usually controlled by tides (i.e. except during floods)?
 NO – go to 2 YES – the wetland class is **Tidal Fringe**
 If yes, is the salinity of the water during periods of annual low flow below 0.5 ppt (parts per thousand)?
 YES – **Freshwater Tidal Fringe** NO – **Saltwater Tidal Fringe (Estuarine)**
*If your wetland can be classified as a Freshwater Tidal Fringe use the forms for **Riverine** wetlands. If it is a Saltwater Tidal Fringe it is rated as an **Estuarine** wetland. Wetlands that were call estuarine in the first and second editions of the rating system are called Salt Water Tidal Fringe in the Hydrogeomorphic Classification. Estuarine wetlands were categorized separately in the earlier editions, and this separation is being kept in this revision. To maintain consistency between editions, the term “Estuarine” wetland is kept. Please note, however, that the characteristics that define Category I and II estuarine wetlands have changed (see p. _____).*
-
2. The entire wetland unit is flat and precipitation is only source (>90%) of water to it. Groundwater and surface water runoff are NOT sources of water to the unit.
 NO – go to 3 YES – The wetland class is **Flats**
 If your wetland can be classified as a “Flats” wetland, use the form for **Depressional** wetlands.
-
3. Does the entire wetland meet both of the following criteria?
 The vegetated part of the wetland is on the shores of a body of permanent open water (without any vegetation on the surface) where at least 20 acres (8ha) in size;
 At least 30% of the open water area is deeper than 6.6 (2 m)?
 NO – go to 4 YES – The wetland class is **Lake-fringe (Lacustrine Fringe)**
-
4. Does the entire wetland meet all of the following criteria?
 The wetland is on a slope (*slope can be very gradual*).
 The water flows through the wetland in one direction (unidirectional) and usually comes from seeps. It may flow subsurface, as sheetflow, or in a swale without distinct banks.
 The water leaves the wetland **without being impounded**?
 NOTE: *Surface water does not pond in these types of wetlands except occasionally in very small and shallow depressions or behind hummocks (depressions are usually <3 ft diameter and less than 1 foot deep).*
 NO – go to 5 YES – The wetland class is **Slope**
-
5. Does the entire wetland meet all of the following criteria?
 The unit is in a valley or stream channel where it gets inundated by overbank flooding from that stream or river.
 The overbank flooding occurs at least once every two years.
 NOTE: *The riverine unit can contain depressions that are filled with water when the river is not flooding..*
 NO – go to 6 YES – The wetland class is **Riverine**
-
6. Is the entire wetland unit in a topographic depression in which water ponds, or is saturated to the surface, at some time of the year. This means that any outlet, if present is higher than the interior of the wetland.
 NO – go to 7 YES – The wetland class is **Depressional**
-
7. Is the entire wetland located in a very flat area with no obvious depression and no overbank flooding. The unit does not pond surface water more than a few inches. The unit seems to be maintained by high groundwater in the area. The wetland may be ditched, but has no obvious natural outlet.
 No – go to 8 YES – The wetland class is **Depressional**
-
8. Your wetland unit seems to be difficult to classify and probably contains several different HGM classes. For example, seeps at the base of a slope may grade into a riverine floodplain, or a small stream within a depressional wetland has a zone of flooding along its sides. GO BACK AND IDENTIFY WHICH OF THE HYDROLOGIC REGIMES DESCRIBED IN QUESTIONS 1-7 APPLY TO DIFFERENT AREAS IN THE UNIT (make a rough sketch to help you decide). Use the following table to identify the appropriate class to use for the rating system if you have several HGM classes present within your wetland. NOTE: Use this table only if the class that is recommended in the second column represents 10% or more of the total area of the wetland unit being rated. If the area of the class listed in column 2 is less than 10% of the unit, classify the wetland using the class that represents more than 90% of the total area.

HGM Classes within the wetland unit being rated	HGM Class to Use in Rating
Slope + Riverine	Riverine
Slope + Depressional	Depressional
Slope + Lake-fringe	Lake-fringe
Depressional + Riverine along stream within boundary	Depressional
Depressional + Lake-fringe	Depressional
Salt Water Tidal Fringe and any other class of freshwater wetland	Treat as ESTUARINE under wetlands with special characteristics

If you are unable still to determine which of the above criteria apply to your wetland, or you have more than 2 HGM classes within a wetland boundary, classify the wetland as **Depressional** for the rating.

D Depressional and Flat Wetlands		Points
WATER QUALITY FUNCTIONS – Indicators that wetland functions to improve water quality.		(only 1 score per box) (see p.38)
D 1	Does the wetland have the <u>potential</u> to improve water quality?	
D 1.1	Characteristics of surface water flows out of the wetland: • Unit is a depression with no surface water leaving it (no outlet) points = 3 <input type="checkbox"/> • Unit has an intermittently flowing, OR highly constricted, permanently flowing outlet ... points = 2 <input checked="" type="checkbox"/> • Unit has an unconstricted, or slightly constricted, surface outlet (<i>permanently flowing</i>) .. points = 1 <input type="checkbox"/> • Unit is a “flat” depression (Q.7 on key), or in the Flats class, with permanent surface outflow and no obvious natural outlet and/or outlet is a man-made ditch..... points = 1 <input type="checkbox"/> <i>(If ditch is not permanently flowing treat unit as “intermittently flowing”)</i> Provide photo or drawing	Figure <input type="checkbox"/> 2
D 1.2	The soil 2 inches below the surface (or duff layer) is clay or organic (<i>use NRCS definitions</i>) YES points = 4 NO points = 0	0
D 1.3	Characteristics of persistent vegetation (emergent, shrub, and/or forest Cowardin class): • Wetland has persistent, ungrazed vegetation > = 95% of area points = 5 <input type="checkbox"/> • Wetland has persistent, ungrazed vegetation > = 1/2 of area points = 3 <input checked="" type="checkbox"/> • Wetland has persistent, ungrazed vegetation > = 1/10 of area points = 1 <input type="checkbox"/> • Wetland has persistent, ungrazed vegetation < 1/10 of area points = 0 <input type="checkbox"/> Map of Cowardin vegetation classes	Figure <input type="checkbox"/> 3
D 1.4	Characteristics of seasonal ponding or inundation: <i>This is the area of the wetland that is ponded for at least 2 months, but dries out sometime during the year. Do not count the area that is permanently ponded. Estimate area as the average condition 5 out of 10 years.</i> • Area seasonally ponded is > 1/2 total area of wetland points = 4 <input type="checkbox"/> • Area seasonally ponded is > 1/4 total area of wetland points = 2 <input checked="" type="checkbox"/> • Area seasonally ponded is < 1/4 total area of wetland points = 0 <input type="checkbox"/> Map of Hydroperiods	Figure <input type="checkbox"/> 2
Total for D 1		<i>Add the points in the boxes above</i> 7
D 2	Does the wetland have the <u>opportunity</u> to improve water quality?	(see p. 44)
Answer YES if you know or believe there are pollutants in groundwater or surface water coming into the wetland that would otherwise reduce water quality in streams, lakes or groundwater downgradient from the wetland? <i>Note which of the following conditions provide the sources of pollutants. A unit may have pollutants coming from several sources, but any single source would qualify as opportunity.</i> <input type="checkbox"/> Grazing in the wetland or within 150 ft <input checked="" type="checkbox"/> Untreated stormwater discharges to wetland <input type="checkbox"/> Tilled fields or orchards within 150 ft. of wetland <input type="checkbox"/> A stream or culvert discharges into wetland that drains developed areas, residential areas, farmed fields, roads, or clear-cut logging <input checked="" type="checkbox"/> Residential, urban areas, golf courses are within 150 ft. of wetland <input type="checkbox"/> Wetland is fed by groundwater high in phosphorus or nitrogen <input type="checkbox"/> Other _____		Multiplier 2
<input checked="" type="checkbox"/> YES multiplier is 2 <input type="checkbox"/> NO multiplier is 1		
◆ TOTAL – Water Quality Functions Multiply the score from D1 by D2; then add score to table on p. 1		14
HYDROLOGIC FUNCTIONS – Indicators that wetland unit functions to reduce flooding and stream degradation.		
D 3	Does the wetland have the <u>potential</u> to reduce flooding and erosion?	(see p.46)
D 3.1	Characteristics of surface water flows out of the wetland unit • Unit is a depression with no surface water leaving it (no outlet) points = 4 <input type="checkbox"/> • Unit has an intermittently flowing, OR highly constricted permanently flowing outlet points = 2 <input checked="" type="checkbox"/> • Unit is a “flat” depression (Q.7 on key) or in the Flats class, with permanent surface outflow and no obvious natural outlet and/or outlet is a man-made ditch..... points = 1 <input type="checkbox"/> <i>(If ditch is not permanently flowing treat unit as “intermittently flowing”)</i> • Unit has an unconstricted, or slightly constricted, surface outlet (<i>permanently flowing</i>) points = 0	2
D 3.2	Depth of storage during wet periods. <i>Estimate the height of ponding above the bottom of the outlet. For units with no outlet measure from the surface of permanent water or deepest part (if dry).</i> • Marks of ponding are 3 ft. or more above the surface or bottom of the outlet points = 7 <input type="checkbox"/> • The wetland is a “headwater” wetland..... points = 5 <input type="checkbox"/> • Marks of ponding between 2 ft. to < 3 ft. from surface or bottom of outlet points = 5 <input type="checkbox"/> • Marks are at least 0.5 ft. to < 2 ft. from surface or bottom of outlet points = 3 <input checked="" type="checkbox"/> • Wetland is flat (yes to Q.2 or Q.7 on key) but has small depressions on the surface that trap water . points = 1 <input type="checkbox"/> • Marks of ponding less than 0.5 ft points = 0 <input type="checkbox"/>	3
D 3.3	Contribution of wetland unit to storage in the watershed: <i>Estimate the ratio of the area of upstream basin contributing surface water to the wetland to the area of the wetland unit itself.</i> • The area of the basin is less than 10 times the area of unit..... points = 5 <input checked="" type="checkbox"/> • The area of the basin is 10 to 100 times the area of the unit..... points = 3 <input type="checkbox"/> • The area of the basin is more than 100 times the area of the unit points = 0 <input type="checkbox"/> • Entire unit is in the FLATS class points = 5 <input type="checkbox"/>	5
Total for D 3		<i>Add the points in the boxes above</i> 10

D 4	<p>Does the wetland have the <u>opportunity</u> to reduce flooding and erosion?</p> <p>Answer YES if the unit is in a location in the watershed where the flood storage, or reduction in water velocity, it provides helps protect downstream property and aquatic resources from flooding or excessive and/or erosive flows. Answer NO if the water coming into the wetland is controlled by a structure such as flood gate, tide gate, flap valve, reservoir etc. OR you estimate that more than 90% of the water in the wetland is from groundwater in areas where damaging groundwater flooding does not occur. <i>Note which of the following indicators of opportunity apply.</i></p> <p><input type="checkbox"/> Wetland is in a headwater of a river or stream that has flooding problems.</p> <p><input checked="" type="checkbox"/> Wetland drains to a river or stream that has flooding problems</p> <p><input type="checkbox"/> Wetland has no outlet and impounds surface runoff water that might otherwise flow into a river or stream that has flooding problems</p> <p><input type="checkbox"/> Other _____</p> <p><input checked="" type="checkbox"/> YES multiplier is 2 <input type="checkbox"/> NO multiplier is 1</p>	<p>(see p. 49)</p> <p>Multiplier</p> <p>2</p>
◆	<p>TOTAL – Hydrologic Functions Multiply the score from D3 by D4; then <i>add score to table on p. 1</i></p>	<p><u>20</u></p>

Comments: _____

These questions apply to wetlands of all HGM classes.		Points																
HABITAT FUNCTIONS – Indicators that wetland functions to provide important habitat.		(only 1 score per box)																
H 1	Does the wetland have the potential to provide habitat for many species?																	
H 1.1	<p>Vegetation structure (see P. 72): Check the types of vegetation classes present (as defined by Cowardin) – Size threshold for each class is 1/4 acre or more than 10% of the area if unit is smaller than 2.5 acres.</p> <p><input type="checkbox"/> Aquatic Bed <input checked="" type="checkbox"/> Emergent plants <input checked="" type="checkbox"/> Scrub/shrub (areas where shrubs have > 30% cover) <input checked="" type="checkbox"/> Forested (areas where trees have > 30% cover)</p> <p>If the unit has a forested class check if: <input type="checkbox"/> The forested class has 3 out of 5 strata (canopy, sub-canopy, shrubs, herbaceous, moss/ground-cover) that each cover 20% within the forested polygon.</p> <p>Add the number of vegetation types that qualify. If you have:</p> <table border="0"> <tr> <td>4 structures or more..... points = 4</td> <td><input type="checkbox"/></td> <td>Map of Cowardin vegetation classes</td> <td></td> </tr> <tr> <td>3 structures..... points = 2</td> <td><input checked="" type="checkbox"/></td> <td>3 structures..... points = 2</td> <td><input checked="" type="checkbox"/></td> </tr> <tr> <td>2 structures..... points = 1</td> <td><input type="checkbox"/></td> <td>1 structure..... points = 0</td> <td><input type="checkbox"/></td> </tr> </table>	4 structures or more..... points = 4	<input type="checkbox"/>	Map of Cowardin vegetation classes		3 structures..... points = 2	<input checked="" type="checkbox"/>	3 structures..... points = 2	<input checked="" type="checkbox"/>	2 structures..... points = 1	<input type="checkbox"/>	1 structure..... points = 0	<input type="checkbox"/>	<p>Figure <input type="checkbox"/></p> <p style="text-align: right;">2</p>				
4 structures or more..... points = 4	<input type="checkbox"/>	Map of Cowardin vegetation classes																
3 structures..... points = 2	<input checked="" type="checkbox"/>	3 structures..... points = 2	<input checked="" type="checkbox"/>															
2 structures..... points = 1	<input type="checkbox"/>	1 structure..... points = 0	<input type="checkbox"/>															
H 1.2	<p>Hydroperiods (see p.73): Check the types of water regimes (hydroperiods) present within the wetland. The water regime has to cover more than 10% of the wetland or 1/4 acre to count (see text for descriptions of hydroperiods).</p> <table border="0"> <tr> <td><input checked="" type="checkbox"/> Permanently flooded or inundated</td> <td>4 or more types present</td> <td>points = 3</td> <td><input checked="" type="checkbox"/></td> </tr> <tr> <td><input checked="" type="checkbox"/> Seasonally flooded or inundated</td> <td>3 or more types present</td> <td>points = 2</td> <td><input type="checkbox"/></td> </tr> <tr> <td><input checked="" type="checkbox"/> Occasionally flooded or inundated</td> <td>2 types present</td> <td>points = 1</td> <td><input type="checkbox"/></td> </tr> <tr> <td><input checked="" type="checkbox"/> Saturated only</td> <td>1 type present</td> <td>points = 0</td> <td><input type="checkbox"/></td> </tr> </table> <p><input checked="" type="checkbox"/> Permanently flowing stream or river in, or adjacent to, the wetland <input type="checkbox"/> Seasonally flowing stream in, or adjacent to, the wetland</p> <p><input type="checkbox"/> Lake-fringe wetland..... = 2 points <input type="checkbox"/> Freshwater tidal wetland..... = 2 points</p> <p style="text-align: right;">Map of hydroperiods</p>	<input checked="" type="checkbox"/> Permanently flooded or inundated	4 or more types present	points = 3	<input checked="" type="checkbox"/>	<input checked="" type="checkbox"/> Seasonally flooded or inundated	3 or more types present	points = 2	<input type="checkbox"/>	<input checked="" type="checkbox"/> Occasionally flooded or inundated	2 types present	points = 1	<input type="checkbox"/>	<input checked="" type="checkbox"/> Saturated only	1 type present	points = 0	<input type="checkbox"/>	<p>Figure <input type="checkbox"/></p> <p style="text-align: right;">3</p>
<input checked="" type="checkbox"/> Permanently flooded or inundated	4 or more types present	points = 3	<input checked="" type="checkbox"/>															
<input checked="" type="checkbox"/> Seasonally flooded or inundated	3 or more types present	points = 2	<input type="checkbox"/>															
<input checked="" type="checkbox"/> Occasionally flooded or inundated	2 types present	points = 1	<input type="checkbox"/>															
<input checked="" type="checkbox"/> Saturated only	1 type present	points = 0	<input type="checkbox"/>															
H 1.3	<p>Richness of Plant Species (see p. 75): Count the number of plant species in the wetland that cover at least 10 ft² (different patches of the same species can be combined to meet the size threshold) You do not have to name the species. Do not include Eurasian Milfoil, reed canarygrass, purple loosestrife, Canadian Thistle.</p> <p>If you counted:</p> <table border="0"> <tr> <td>> 19 species..... points = 2</td> <td><input type="checkbox"/></td> </tr> <tr> <td>5 – 19 species..... points = 1</td> <td><input checked="" type="checkbox"/></td> </tr> <tr> <td>< 5 species..... points = 0</td> <td><input type="checkbox"/></td> </tr> </table> <p>List species below if you want to:</p> <hr/>	> 19 species..... points = 2	<input type="checkbox"/>	5 – 19 species..... points = 1	<input checked="" type="checkbox"/>	< 5 species..... points = 0	<input type="checkbox"/>	<p style="text-align: right;">1</p>										
> 19 species..... points = 2	<input type="checkbox"/>																	
5 – 19 species..... points = 1	<input checked="" type="checkbox"/>																	
< 5 species..... points = 0	<input type="checkbox"/>																	
H 1.4	<p>Interspersion of Habitats (see p. 76): Decided from the diagrams below whether interspersion between Cowardin vegetation (described in H1.1), or the classes and unvegetated areas (can include open water or mudflats) is high, medium, low, or none.</p> <div style="text-align: center;"> <p>None = 0 points Low = 1 point Moderate = 2 points</p> <p>High = 3 points [riparian braided channels]</p> </div> <p>Note: If you have 4 or more classes or 3 vegetation classes and open water, the rating is always “high”.</p> <p style="text-align: right;">Use map of Cowardin classes.</p>	<p>Figure <input type="checkbox"/></p> <p style="text-align: right;">3</p>																
H 1.5	<p>Special Habitat Features (see p. 77): Check the habitat features that are present in the wetland. The number of checks is the number of points you put into the next column.</p> <p><input checked="" type="checkbox"/> Large, downed, woody debris within the wetland (> 4 in. diameter and 6 ft. long) <input checked="" type="checkbox"/> Standing snags (diameter at the bottom > 4 inches) in the wetland <input type="checkbox"/> Undercut banks are present for at least 6.6 ft. (2m) and/or overhanging vegetation extends at least 3.3 ft. (1m) over a stream (or ditch) in, or contiguous with the unit, for at least 33 ft. (10m) <input type="checkbox"/> Stable steep banks of fine material that might be used by beaver or muskrat for denning (> 30 degree slope) OR signs of recent beaver activity are present (cut shrubs or trees that have not yet turned grey/brown) <input type="checkbox"/> At least 1/4 acre of thin-stemmed persistent vegetation or woody branches are present in areas that are permanently or seasonally inundated (structures for egg-laying by amphibians) <input type="checkbox"/> Invasive plants cover less than 25% of the wetland area in each stratum of plants</p> <p>NOTE: The 20% stated in early printings of the manual on page 78 is an error.</p>	<p style="text-align: right;">2</p>																
H 1 TOTAL Score – potential for providing habitat		11																

Add the points in the column above

H 2	Does the wetland have the <u>opportunity</u> to provide habitat for many species?	(only 1 score per box)
	<p>H 2.1 <u>Buffers</u> (see P. 80): Choose the description that best represents condition of buffer of wetland unit. The highest scoring criterion that applies to the wetland is to be used in the rating. See text for definition of "undisturbed".</p> <p><input type="checkbox"/> 100m (330 ft) of relatively undisturbed vegetated areas, rocky areas, or open water > 95% of circumference. No structures are within the undisturbed part of buffer (relatively undisturbed also means no grazing, no landscaping, no daily human use)..... points = 5</p> <p><input type="checkbox"/> 100m (330 ft) of relatively undisturbed vegetated areas, rocky areas, or open water > 50% circumference points = 4</p> <p><input type="checkbox"/> 50m (170 ft) of relatively undisturbed vegetated areas, rocky areas, or open water > 95% circumference points = 4</p> <p><input type="checkbox"/> 100m (330 ft) of relatively undisturbed vegetated areas, rocky areas, or open water > 25% circumference points = 3</p> <p><input type="checkbox"/> 50m (170 ft) of relatively undisturbed vegetated areas, rocky areas, or open water for > 50% circumference points = 3</p> <p>If buffer does not meet any of the criteria above:</p> <p><input type="checkbox"/> No paved areas (except paved trails) or buildings within 25m (80 ft) of wetland > 95% circumference. Light to moderate grazing or lawns are OK points = 2</p> <p><input type="checkbox"/> No paved areas of buildings within 50m of wetland for > 50% circumference. Light to moderate grazing or lawns are OK points = 2</p> <p><input type="checkbox"/> Heavy grazing in buffer points = 1</p> <p><input type="checkbox"/> Vegetated buffers are < 2m wide (6.6 ft) for more than 95% circumference (e.g. tilled fields, paving, basalt bedrock extend to edge of wetland) points = 0</p> <p><input checked="" type="checkbox"/> Buffer does not meet any of the criteria above points = 1</p> <p style="text-align: right;">Arial photo showing buffers</p>	<p>Figure <input type="checkbox"/></p> <p style="text-align: right;">1</p>
	<p>H 2.2 <u>Corridors and Connections</u> (see p. 81)</p> <p>H 2.2.1 Is the wetland part of a relatively undisturbed and unbroken vegetated corridor (either riparian or upland) that is at least 150 ft. wide, has at least a 30% cover of shrubs, forest or native undisturbed prairie, that connects to estuaries, other wetlands or undisturbed uplands that are at least 250 acres in size? (<i>Dams in riparian corridors, heavily used gravel roads, paved roads, are considered breaks in the corridor.</i>)</p> <p style="padding-left: 40px;"><input type="checkbox"/> YES = 4 points (go to H 2.3) <input checked="" type="checkbox"/> NO = go to H 2.2.2</p> <p>H. 2.2.2 Is the wetland part of a relatively undisturbed and unbroken vegetated corridor (either riparian or upland) that is at least 50 ft. wide, has at least 30% cover of shrubs or forest, and connects to estuaries, other wetlands or undisturbed uplands that are at least 25 acres in size? OR a Lake-fringe wetland, if it does not have an undisturbed corridor as in the question above?</p> <p style="padding-left: 40px;"><input type="checkbox"/> YES = 2 points (go to H 2.3) <input checked="" type="checkbox"/> NO = go to H 2.2.3</p> <p>H. 2.2.3 Is the wetland:</p> <ul style="list-style-type: none"> • Within 5 mi (8km) of a brackish or salt water estuary OR • Within 3 miles of a large field or pasture (> 40 acres) OR • Within 1 mile of a lake greater than 20 acres? <p style="padding-left: 100px;"><input checked="" type="checkbox"/> YES = 1 point <input type="checkbox"/> NO = 0 points</p>	<p style="text-align: right;">1</p>

Comments: _____

	<p>H 2.3 <u>Near or adjacent to other priority habitats listed by WDFW</u> (see p. 82): (see new and complete descriptions of WDFW priority habitats, and the counties in which they can be found, in the PHS report http://wdfw.wa.gov/hab/phslist.htm) Which of the following priority habitats are within 330 ft. (100m) of the wetland unit? <i>NOTE: the connections do not have to be relatively undisturbed.</i></p> <p><input type="checkbox"/> Aspen Stands: Pure or mixed stands of aspen greater than 0.4 ha (1 acre).</p> <p><input type="checkbox"/> Biodiversity Areas and Corridors: Areas of habitat that are relatively important to various species of native fish and wildlife (full descriptions in WDFW PHS report p. 152).</p> <p><input type="checkbox"/> Herbaceous Balds: Variable size patches of grass and forbs on shallow soils over bedrock.</p> <p><input type="checkbox"/> Old-growth/Mature forests: (Old-growth west of Cascade crest) Stands of at least 2 tree species, forming a multi-layered canopy with occasional small openings; with at least 20 trees/ha (8 trees/acre) > 81 cm (32 in) dbh or > 200 years of age. (Mature forests) Stands with average diameters exceeding 53 cm (21 in) dbh; crown cover may be less than 100%; decay, decadence, numbers of snags, and quantity of large downed material is generally less than that found in old-growth; 80 - 200 years old west of the Cascade crest.</p> <p><input type="checkbox"/> Oregon white Oak: Woodlands Stands of pure oak or oak/conifer associations where canopy coverage of the oak component is important (full descriptions in WDFW PHS report p. 158).</p> <p><input checked="" type="checkbox"/> Riparian: The area adjacent to aquatic systems with flowing water that contains elements of both aquatic and terrestrial ecosystems which mutually influence each other.</p> <p><input type="checkbox"/> Westside Prairies: Herbaceous, non-forested plant communities that can either take the form of a dry prairie or a wet prairie (full descriptions in WDFW PHS report p. 161).</p> <p><input checked="" type="checkbox"/> Instream: The combination of physical, biological, and chemical processes and conditions that interact to provide functional life history requirements for instream fish and wildlife resources.</p> <p><input type="checkbox"/> Nearshore: Relatively undisturbed nearshore habitats. These include Coastal Nearshore, Open Coast Nearshore, and Puget Sound Nearshore. (full descriptions of habitats and the definition of relatively undisturbed are in WDFW report: pp. 167-169 and glossary in Appendix A).</p> <p><input type="checkbox"/> Caves: A naturally occurring cavity, recess, void, or system of interconnected passages under the earth in soils, rock, ice, or other geological formations and is large enough to contain a human.</p> <p><input type="checkbox"/> Cliffs: Greater than 7.6 m (25 ft) high and occurring below 5000 ft.</p> <p><input type="checkbox"/> Talus: Homogenous areas of rock rubble ranging in average size 0.15 - 2.0 m (0.5 - 6.5 ft), composed of basalt, andesite, and/or sedimentary rock, including riprap slides and mine tailings. May be associated with cliffs.</p> <p><input type="checkbox"/> Snags and Logs: Trees are considered snags if they are dead or dying and exhibit sufficient decay characteristics to enable cavity excavation/use by wildlife. Priority snags have a diameter at breast height of > 51 cm (20 in) in western Washington and are > 2 m (6.5 ft) in height. Priority logs are > 30 cm (12 in) in diameter at the largest end, and > 6 m (20 ft) long.</p> <p style="text-align: right;">If wetland has 3 or more priority habitats = 4 points If wetland has 2 priority habitats = 3 points If wetland has 1 priority habitat = 1 point No habitats = 0 points</p> <p>Note: All vegetated wetlands are by definition a priority habitat but are not included in this list. Nearby wetlands are addressed in question H 2.4)</p>	3
	<p>H 2.4 <u>Wetland Landscape:</u> Choose the one description of the landscape around the wetland that best fits (see p. 84)</p> <ul style="list-style-type: none"> • There are at least 3 other wetlands within 1/2 mile, and the connections between them are relatively undisturbed (light grazing between wetlands OK, as is lake shore with some boating, but connections should NOT be bisected by paved roads, fill, fields, or other development.... points = 5 <input type="checkbox"/> • The wetland is Lake-fringe on a lake with little disturbance and there are 3 other lake-fringe wetlands within 1/2 mile points = 5 <input type="checkbox"/> • There are at least 3 other wetlands within 1/2 mile, BUT the connections between them are disturbed. points = 3 <input checked="" type="checkbox"/> • The wetland fringe on a lake with disturbance and there are 3 other lake-fringe wetlands within 1/2 mile points = 3 <input type="checkbox"/> • There is at least 1 wetland within 1/2 mile points = 2 <input type="checkbox"/> • There are no wetlands within 1/2 mile..... points = 0 <input type="checkbox"/> 	3
	<p>H 2 TOTAL Score – opportunity for providing habitat Add the scores from H2.1, H2.2, H2.3, H2.4</p>	8
	<p style="text-align: right;">TOTAL for H 1 from page 8</p>	11
◆	<p>Total Score for Habitat Functions Add the points for H 1 and H 2; then record the result on p. 1</p>	19

Comments: _____

CATEGORIZATION BASED ON SPECIAL CHARACTERISTICS

Please determine if the wetland meets the attributes described below and circle the appropriate answers and Category.

Wetland Type – Check off any criteria that apply to the wetland. Circle the Category when the appropriate criteria are met.	
SC1	<p>Estuarine wetlands? (see p.86)</p> <p>Does the wetland unit meet the following criteria for Estuarine wetlands?</p> <p><input type="checkbox"/> The dominant water regime is tidal, <input type="checkbox"/> Vegetated, and <input type="checkbox"/> With a salinity greater than 0.5 ppt.</p> <p style="text-align: center;"><input type="checkbox"/> YES = Go to SC 1.1 <input checked="" type="checkbox"/> NO</p>
	<p>SC 1.1 Is the wetland unit within a National Wildlife Refuge, National Park, National Estuary Reserve, Natural Area Preserve, State Park or Educational, Environmental, or Scientific Reserve designated under WAC 332-30-151? <input type="checkbox"/> YES = Category I <input type="checkbox"/> NO = go to SC 1.2</p>
	<p>SC 1.2 Is the wetland at least 1 acre in size and meets at least two of the following conditions?</p> <p style="text-align: center;"><input type="checkbox"/> YES = Category I <input type="checkbox"/> NO = Category II</p> <p><input type="checkbox"/> The wetland is relatively undisturbed (has no diking, ditching, filling, cultivation, grazing, and has less than 10% cover of non-native plant species. If the non-native <i>Spartina</i> spp. are only species that cover more than 10% of the wetland, then the wetland should be given a dual rating (I/II). The area of <i>Spartina</i> would be rated a Category II while the relatively undisturbed upper marsh with native species would be a Category I. Do not, however, exclude the area of <i>Spartina</i> in determining the size threshold of 1 acre.</p> <p><input type="checkbox"/> At least 3/4 of the landward edge of the wetland has a 100 ft. buffer of shrub, forest, or un-grazed or un-mowed grassland</p> <p><input type="checkbox"/> The wetland has at least 2 of the following features: tidal channels, depressions with open water, or contiguous freshwater wetlands.</p>
SC2	<p>Natural Heritage Wetlands (see p. 87)</p> <p>Natural Heritage wetlands have been identified by the Washington Natural Heritage Program/DNR as either high quality undisturbed wetlands or wetlands that support state Threatened, Endangered, or Sensitive plant species.</p> <p>SC 2.1 Is the wetland being rated in a Section/Township/Range that contains a natural heritage wetland? (This question is used to screen out most sites before you need to contact WNHP/DNR.)</p> <p style="text-align: center;"><input type="checkbox"/> S/T/R information from Appendix D <input type="checkbox"/> or accessed from WNHP/DNR web site <input type="checkbox"/> YES Contact WNHP/DNR (see p. 79) and go to SC 2.2 <input checked="" type="checkbox"/> NO</p> <p>SC 2.2 Has DNR identified the wetland as a high quality undisturbed wetland or as a site with state threatened or endangered plant species?</p> <p style="text-align: center;"><input type="checkbox"/> YES = Category 1 <input checked="" type="checkbox"/> NO not a Heritage Wetland</p>
SC3	<p>Bogs (see p. 87)</p> <p>Does the wetland (or any part of the unit) meet both the criteria for soils and vegetation in bogs? Use the key below to identify if the wetland is a bog. If you answer yes you will still need to rate the wetland based on its function.</p> <ol style="list-style-type: none"> Does the unit have organic soil horizons (i.e. layers of organic soil), either peats or mucks, that compose 16 inches or more of the first 32 inches of soil profile? (See Appendix B for a field key to identify organic soils)? <input type="checkbox"/> YES = go to question 3 <input checked="" type="checkbox"/> NO = go to question 2 Does the wetland have organic soils, either peats or mucks that are less than 16 inches deep over bedrock, or an impermeable hardpan such as clay or volcanic ash, or that are floating on a lake or pond? <input type="checkbox"/> YES = go to question 3 <input checked="" type="checkbox"/> NO = is not a bog for purpose of rating Does the unit have more than 70% cover of mosses at ground level, AND other plants, if present, consist of the “bog” species listed in Table 3 as a significant component of the vegetation (more than 30% of the total shrub and herbaceous cover consists of species in Table 3)? <p style="text-align: center;"><input type="checkbox"/> YES = Is a bog for purpose of rating <input checked="" type="checkbox"/> NO = go to question 4</p> <p>NOTE: If you are uncertain about the extent of mosses in the understory you may substitute that criterion by measuring the pH of the water that seeps into a hole dug at least 16” deep. If the pH is less than 5.0 and the “bog” plant species in Table 3 are present, the wetland is a bog.</p> <ol style="list-style-type: none"> Is the unit forested (> 30% cover) with sitka spruce, subalpine fir, western red cedar, western hemlock, lodgepole pine, quaking aspen, Englemann’s spruce, or western white pine. WITH any of the species (or combination of species) on the bog species plant list in Table 3 as a significant component of the ground cover (> 30% coverage of the total shrub/herbaceous cover)? <p style="text-align: center;"><input type="checkbox"/> YES = Category I <input checked="" type="checkbox"/> NO = Is not a bog for purpose of rating</p>

SC4	<p>Forested Wetlands (see p. 90)</p> <p>Does the wetland have at least 1 acre of forest that meet one of these criteria for the Department of Fish and Wildlife's forests as priority habitats? <i>If you answer yes you will still need to rate the wetland based on its function.</i></p> <p><input type="checkbox"/> Old-growth forests: (west of Cascade Crest) Stands of at least two three species forming a multi-layered canopy with occasional small openings; with at least 8 trees/acre (20 trees/hectare) that are at least 200 years of age OR have a diameter at breast height (dbh) of 32 inches (81 cm or more). NOTE: The criterion for dbh is based on measurements for upland forests. Two-hundred year old trees in wetlands will often have a smaller dbh because their growth rates are often slower. The DFW criterion is and "OR" so old-growth forests do not necessarily have to have trees of this diameter.</p> <p><input type="checkbox"/> Mature forests: (west of the Cascade Crest) Stands where the largest trees are 80 – 200 years old OR have an average diameters (dbh) exceeding 21 inches (53 cm); crown cover may be less than 100%; decay, decadence, numbers of snags, and quantity of large downed material is generally less than that found in old-growth.</p> <p><input type="checkbox"/> YES = Category I <input checked="" type="checkbox"/> NO = not a forested wetland with special characteristics</p>	<p>Cat. I <input type="checkbox"/></p>
SC5	<p>Wetlands in Coastal Lagoons (see p. 91)</p> <p>Does the wetland meet all of the following criteria of a wetland in a coastal lagoon?</p> <p><input type="checkbox"/> The wetland lies in a depression adjacent to marine waters that is wholly or partially separated from marine waters by sandbanks, gravel banks, shingle, or, less frequently, rocks.</p> <p><input type="checkbox"/> The lagoon in which the wetland is located contains surface water that is saline or brackish (> 0.5 ppt) during most of the year in at least a portion of the lagoon (<i>needs to be measured near the bottom.</i>)</p> <p><input type="checkbox"/> YES = Go to SC 5.1 <input checked="" type="checkbox"/> NO not a wetland in a coastal lagoon</p> <p>SC 5.1 Does the wetland meet all of the following three conditions?</p> <p><input type="checkbox"/> The wetland is relatively undisturbed (has no diking, ditching, filling, cultivation, grazing) and has less than 20% cover of invasive plant species (see list of invasive species on p. 74).</p> <p><input type="checkbox"/> At least 3/4 of the landward edge of the wetland has a 100 ft. buffer of shrub, forest, or un-grazed or un-mowed grassland.</p> <p><input type="checkbox"/> The wetland is larger than 1/10 acre (4350 square ft.)</p> <p><input type="checkbox"/> YES = Category I <input type="checkbox"/> NO = Category II</p>	<p style="background-color: #cccccc;"> </p> <p>Cat. I <input type="checkbox"/></p> <p>Cat. II <input type="checkbox"/></p>
SC6	<p>Interdunal Wetlands (see p. 93)</p> <p>Is the wetland west of the 1889 line (also called the Western Boundary of Upland Ownership or WBUO)?</p> <p><input type="checkbox"/> YES = Go to SC 6.1 <input checked="" type="checkbox"/> NO not an interdunal wetland for rating</p> <p><i>If you answer yes you will still need to rate the wetland based on its functions.</i></p> <p>In practical terms that means the following geographic areas:</p> <ul style="list-style-type: none"> • Long Beach Peninsula -- lands west of SR 103 • Grayland-Westport -- lands west of SR 105 • Ocean Shores-Copalis – lands west of SR 115 and SR 109 <p>SC 6.1 Is the wetland one acre or larger, or is it in a mosaic of wetlands that is one acre or larger?</p> <p><input type="checkbox"/> YES = Category II <input type="checkbox"/> NO = go to SC 6.2</p> <p>SC 6.2 Is the wetland between 0.1 and 1 acre, or is it in a mosaic of wetlands that is between 0.1 and 1 acre?</p> <p><input type="checkbox"/> YES = Category III</p>	<p>Cat. II <input type="checkbox"/></p> <p>Cat. III <input type="checkbox"/></p>
◆	<p>Category of wetland based on Special Characteristics</p> <p>Choose the "highest" rating if wetland falls into several categories, and record on p. 1. If you answered NO for all types enter "Not Applicable" on p. 1</p>	<p>NA</p>

Comments:

WETLAND RATING FORM – WESTERN WASHINGTON
Version 2 – Updated July 2006 to increase accuracy and reproducibility among users
Updated Oct. 2008 with the new WDFW definitions for priority habitats

Name of wetland (if known): Bellefield North

Date of site visit: May 17, 2013

Rated by: C. Douglas & J. Pursley Trained by Ecology? Yes No

Date of training: May 2007

SEC: 5 TOWNSHP: 24N RNGE: 5E

Is S/T/R in Appendix D? Yes No

Map of wetland unit: Figure _____ Estimated size _____

SUMMARY OF RATING

Category based on FUNCTIONS provided by wetland: I II III IV

Category I =	Score > 70
Category II =	Score 51 - 69
Category III =	Score 30 – 50
Category IV =	Score < 30

Score for Water Quality Functions	20
Score for Hydrologic Functions	16
Score for Habitat Functions	17
TOTAL Score for Functions	53

Category based on SPECIAL CHARACTERISTICS of Wetland I II Does not apply

Final Category (choose the “highest” category from above”)

II

Summary of basic information about the wetland unit.

Wetland Unit has Special Characteristics		Wetland HGM Class used for Rating	
Estuarine	<input type="checkbox"/>	Depressional	<input type="checkbox"/>
Natural Heritage Wetland	<input type="checkbox"/>	Riverine	<input checked="" type="checkbox"/>
Bog	<input type="checkbox"/>	Lake-fringe	<input type="checkbox"/>
Mature Forest	<input type="checkbox"/>	Slope	<input checked="" type="checkbox"/>
Old Growth Forest	<input type="checkbox"/>	Flats	<input type="checkbox"/>
Coastal Lagoon	<input type="checkbox"/>	Freshwater Tidal	<input type="checkbox"/>
Interdunal	<input type="checkbox"/>		<input type="checkbox"/>
None of the above	<input checked="" type="checkbox"/>	Check if unit has multiple HGM classes present	<input checked="" type="checkbox"/>

Does the wetland being rated meet any of the criteria below? If you answer YES to any of the questions below you will need to protect the wetland according to the regulations regarding the special characteristics found in the wetland.

Check List for Wetlands that Need Additional Protection (in addition to the protection recommended for its category)	YES	NO
SP1. <i>Has the wetland unit been documented as a habitat for any Federally listed Threatened or Endangered animal or plant species (T/E species)?</i> For the purposes of this rating system, “documented” means the wetland is on the appropriate state or federal database.	<input checked="" type="checkbox"/>	<input type="checkbox"/>
SP2. <i>Has the wetland unit been documented as habitat for any State listed Threatened or Endangered animal species?</i> For the purposes of this rating system, “documented” means the wetland is on the appropriate state database. Note: Wetlands with State listed plant species are categorized as Category 1 Natural Heritage Wetlands (see p. 19 of data form).	<input checked="" type="checkbox"/>	<input type="checkbox"/>
SP3. <i>Does the wetland unit contain individuals of Priority species listed by the WDFW for the state?</i>	<input checked="" type="checkbox"/>	<input type="checkbox"/>
SP4. <i>Does the wetland unit have a local significance in addition to its functions?</i> For example, the wetland has been identified in the Shoreline Master Program, the Critical Areas Ordinance, or in a local management plan as having special significance.	<input type="checkbox"/>	<input checked="" type="checkbox"/>

To complete the next part of the data sheet you will need to determine the Hydrogeomorphic Class of the wetland being rated.

The hydrogeomorphic classification groups wetlands in to those that function in similar ways. This simplifies the questions needed to answer how well the wetland functions. The Hydrogeomorphic Class of a wetland can be determined using the key below. See p. 24 for more detailed instructions on classifying wetlands.

Classification of Vegetated Wetlands for Western Washington

If the hydrologic criteria listed in each question do not apply to the entire unit being rated, you probably have a unit with multiple HGM classes. In this case, identify which hydrologic criteria in questions 1-7 apply, and go to Question 8.

1. Are the water levels in the entire unit usually controlled by tides (i.e. except during floods)?
 NO – go to 2 YES – the wetland class is **Tidal Fringe**
 If yes, is the salinity of the water during periods of annual low flow below 0.5 ppt (parts per thousand)?
 YES – **Freshwater Tidal Fringe** NO – **Saltwater Tidal Fringe (Estuarine)**
*If your wetland can be classified as a Freshwater Tidal Fringe use the forms for **Riverine** wetlands. If it is a Saltwater Tidal Fringe it is rated as an **Estuarine** wetland. Wetlands that were call estuarine in the first and second editions of the rating system are called Salt Water Tidal Fringe in the Hydrogeomorphic Classification. Estuarine wetlands were categorized separately in the earlier editions, and this separation is being kept in this revision. To maintain consistency between editions, the term “Estuarine” wetland is kept. Please note, however, that the characteristics that define Category I and II estuarine wetlands have changed (see p. _____).*
-
2. The entire wetland unit is flat and precipitation is only source (>90%) of water to it. Groundwater and surface water runoff are NOT sources of water to the unit.
 NO – go to 3 YES – The wetland class is **Flats**
 If your wetland can be classified as a “Flats” wetland, use the form for **Depressional** wetlands.
-
3. Does the entire wetland meet both of the following criteria?
 The vegetated part of the wetland is on the shores of a body of permanent open water (without any vegetation on the surface) where at least 20 acres (8ha) in size;
 At least 30% of the open water area is deeper than 6.6 (2 m)?
 NO – go to 4 YES – The wetland class is **Lake-fringe (Lacustrine Fringe)**
-
4. Does the entire wetland meet all of the following criteria?
 The wetland is on a slope (*slope can be very gradual*).
 The water flows through the wetland in one direction (unidirectional) and usually comes from seeps. It may flow subsurface, as sheetflow, or in a swale without distinct banks.
 The water leaves the wetland **without being impounded**?
 NOTE: *Surface water does not pond in these types of wetlands except occasionally in very small and shallow depressions or behind hummocks (depressions are usually <3 ft diameter and less than 1 foot deep).*
 NO – go to 5 YES – The wetland class is **Slope**
-
5. Does the entire wetland meet all of the following criteria?
 The unit is in a valley or stream channel where it gets inundated by overbank flooding from that stream or river.
 The overbank flooding occurs at least once every two years.
 NOTE: *The riverine unit can contain depressions that are filled with water when the river is not flooding..*
 NO – go to 6 YES – The wetland class is **Riverine**
-
6. Is the entire wetland unit in a topographic depression in which water ponds, or is saturated to the surface, at some time of the year. This means that any outlet, if present is higher than the interior of the wetland.
 NO – go to 7 YES – The wetland class is **Depressional**
-
7. Is the entire wetland located in a very flat area with no obvious depression and no overbank flooding. The unit does not pond surface water more than a few inches. The unit seems to be maintained by high groundwater in the area. The wetland may be ditched, but has no obvious natural outlet.
 No – go to 8 YES – The wetland class is **Depressional**
-
8. Your wetland unit seems to be difficult to classify and probably contains several different HGM classes. For example, seeps at the base of a slope may grade into a riverine floodplain, or a small stream within a depressional wetland has a zone of flooding along its sides. GO BACK AND IDENTIFY WHICH OF THE HYDROLOGIC REGIMES DESCRIBED IN QUESTIONS 1-7 APPLY TO DIFFERENT AREAS IN THE UNIT (make a rough sketch to help you decide). Use the following table to identify the appropriate class to use for the rating system if you have several HGM classes present within your wetland. NOTE: Use this table only if the class that is recommended in the second column represents 10% or more of the total area of the wetland unit being rated. If the area of the class listed in column 2 is less than 10% of the unit, classify the wetland using the class that represents more than 90% of the total area.

HGM Classes within the wetland unit being rated	HGM Class to Use in Rating
Slope + Riverine	Riverine
Slope + Depressional	Depressional
Slope + Lake-fringe	Lake-fringe
Depressional + Riverine along stream within boundary	Depressional
Depressional + Lake-fringe	Depressional
Salt Water Tidal Fringe and any other class of freshwater wetland	Treat as ESTUARINE under wetlands with special characteristics

If you are unable still to determine which of the above criteria apply to your wetland, or you have more than 2 HGM classes within a wetland boundary, classify the wetland as **Depressional** for the rating.

R Riverine and Freshwater Tidal Fringe Wetlands		Points
WATER QUALITY FUNCTIONS – Indicators that wetland functions to improve water quality.		(only 1 score per box)
R 1	Does the wetland have the <u>potential</u> to improve water quality? (see p.52)	
	R 1.1 Area of surface depressions within the riverine wetland that can trap sediments during a flooding event: <ul style="list-style-type: none"> • Depressions cover > 3/4 area of wetland points = 8 <input type="checkbox"/> • Depressions cover > 1/2 area of wetland points = 4 <input type="checkbox"/> (If depressions > 1/2 of area of unit draw polygons on aerial photo or map) • Depressions present but cover < 1/2 area of wetland. points = 2 <input checked="" type="checkbox"/> • No depressions present points = 0 <input type="checkbox"/> 	Figure <input type="checkbox"/> 2
	R 1.2 Characteristics of the vegetation in the unit (areas with >90% cover at person height): <ul style="list-style-type: none"> • Trees or shrubs > 2/3 area of the unit points = 8 <input checked="" type="checkbox"/> • Trees or shrubs > 1/3 area of the wetland points = 6 <input type="checkbox"/> • Ungrazed, herbaceous plants > 2/3 area of unit points = 6 <input type="checkbox"/> • Ungrazed herbaceous plants > 1/3 area of unit points = 3 <input type="checkbox"/> • Trees, shrubs, and ungrazed herbaceous < 1/3 area of unit points = 0 <input type="checkbox"/> 	Figure <input type="checkbox"/> 8
Aerial photo or map showing polygons of different vegetation types		
Add the points in the boxes above		10
R 2	Does the wetland have the <u>opportunity</u> to improve water quality?	(see p. 53)
	Answer YES if you know or believe there are pollutants in groundwater or surface water coming into the wetland that would otherwise reduce water quality in streams, lakes or groundwater downgradient from the wetland. <i>Note which of the following conditions provide the sources of pollutants. A unit may have pollutants coming from several sources, but any single source would qualify as opportunity.</i> <ul style="list-style-type: none"> <input type="checkbox"/> Grazing in the wetland or within 150 ft <input checked="" type="checkbox"/> Untreated stormwater discharges to wetland <input type="checkbox"/> Tilled fields or orchards within 150 ft. of wetland <input type="checkbox"/> A stream or culvert discharges into wetland that drains developed areas, residential areas, farmed fields, roads, or clear-cut logging <input checked="" type="checkbox"/> Residential, urban areas, golf courses are within 150 ft. of wetland <input type="checkbox"/> The river or stream linked to the wetland has a contributing basin where human activities have raised levels of sediment, toxic compounds or nutrients in the river water above standards for water quality. <input type="checkbox"/> Other _____ 	Multiplier 2
YES multiplier is 2 NO multiplier is 1		
◆ TOTAL – Water Quality Functions Multiply the score from R1 by R2; then <i>add score to table on p. 1</i>		20
HYDROLOGIC FUNCTIONS – Indicators that wetland functions to reduce flooding and stream erosion.		
R 3	Does the wetland have the <u>potential</u> to reduce flooding and erosion?	(see p.54)
	R 3.1 Characteristics of the overbank storage the wetland provides: <i>Estimate the average width of the wetland perpendicular to the direction of the flow and the width of the stream or river channel (distance between banks). Calculate the ratio: (average width of unit) / (average width of stream between banks).</i> <ul style="list-style-type: none"> • If the ratio is more than 20 points = 9 <input type="checkbox"/> • If the ratio is between 10 – 20 points = 6 <input type="checkbox"/> • If the ratio is 5- <10 points = 4 <input type="checkbox"/> • If the ratio is 1- <5 points = 2 <input type="checkbox"/> • If the ratio is < 1 points = 1 <input checked="" type="checkbox"/> 	Figure <input type="checkbox"/> 1
	R 3.2 Characteristics of vegetation that slow down water velocities during floods: <i>Treat large woody debris as “forest or shrub”. Choose the points appropriate for the best description. (polygons need to have >90% cover at person height NOT Cowardin classes):</i> <ul style="list-style-type: none"> • Forest or shrub for > 1/3 area OR herbaceous plants > 2/3 area points = 7 <input checked="" type="checkbox"/> • Forest or shrub for > 1/10 area OR herbaceous plants > 1/3 area points = 4 <input type="checkbox"/> • Vegetation does not meet above criteria points = 0 <input type="checkbox"/> 	Figure <input type="checkbox"/> 7
Aerial photo or map showing polygons of different vegetation types		
Add the points in the boxes above		8
R 4	Does the wetland have the <u>opportunity</u> to reduce flooding and erosion?	(see p.57)
	Answer YES if the wetland is in a location in the watershed where the flood storage, or reduction in water velocity, it provides helps protect downstream property and aquatic resources from flooding or excessive and/or erosive flows. <i>Note which of the following conditions apply.</i> <ul style="list-style-type: none"> <input checked="" type="checkbox"/> There are human structures and activities downstream (roads, buildings, bridges, farms) that can be damaged by flooding. <input checked="" type="checkbox"/> There are natural resources downstream (e.g. salmon redds) that can be damaged by flooding <input type="checkbox"/> Other _____ 	Multiplier 2
(Answer NO if the major source of water to the wetland is controlled by a reservoir or the wetland is tidal fringe along the sides of a dike)		
<input checked="" type="checkbox"/> YES multiplier is 2 <input type="checkbox"/> NO multiplier is 1		
◆ TOTAL – Hydrologic Functions Multiply the score from R3 by R4; then <i>add score to table on p. 1</i>		16

Comments: _____

These questions apply to wetlands of all HGM classes.		Points																
HABITAT FUNCTIONS – Indicators that wetland functions to provide important habitat.		(only 1 score per box)																
H 1	Does the wetland have the potential to provide habitat for many species?																	
H 1.1	<p>Vegetation structure (see P. 72): Check the types of vegetation classes present (as defined by Cowardin) – Size threshold for each class is 1/4 acre or more than 10% of the area if unit is smaller than 2.5 acres.</p> <p><input type="checkbox"/> Aquatic Bed <input type="checkbox"/> Emergent plants <input checked="" type="checkbox"/> Scrub/shrub (areas where shrubs have > 30% cover) <input checked="" type="checkbox"/> Forested (areas where trees have > 30% cover)</p> <p>If the unit has a forested class check if: <input type="checkbox"/> The forested class has 3 out of 5 strata (canopy, sub-canopy, shrubs, herbaceous, moss/ground-cover) that each cover 20% within the forested polygon. Add the number of vegetation types that qualify. If you have:</p> <table border="0"> <tr> <td>4 structures or more..... points = 4</td> <td><input type="checkbox"/></td> <td>Map of Cowardin vegetation classes</td> <td></td> </tr> <tr> <td>3 structures..... points = 2</td> <td><input checked="" type="checkbox"/></td> <td>3 structures..... points = 2</td> <td><input checked="" type="checkbox"/></td> </tr> <tr> <td>2 structures..... points = 1</td> <td><input checked="" type="checkbox"/></td> <td>1 structure..... points = 0</td> <td><input type="checkbox"/></td> </tr> </table>	4 structures or more..... points = 4	<input type="checkbox"/>	Map of Cowardin vegetation classes		3 structures..... points = 2	<input checked="" type="checkbox"/>	3 structures..... points = 2	<input checked="" type="checkbox"/>	2 structures..... points = 1	<input checked="" type="checkbox"/>	1 structure..... points = 0	<input type="checkbox"/>	<p>Figure <input type="checkbox"/></p> <p>1</p>				
4 structures or more..... points = 4	<input type="checkbox"/>	Map of Cowardin vegetation classes																
3 structures..... points = 2	<input checked="" type="checkbox"/>	3 structures..... points = 2	<input checked="" type="checkbox"/>															
2 structures..... points = 1	<input checked="" type="checkbox"/>	1 structure..... points = 0	<input type="checkbox"/>															
H 1.2	<p>Hydroperiods (see p.73): Check the types of water regimes (hydroperiods) present within the wetland. The water regime has to cover more than 10% of the wetland or 1/4 acre to count (see text for descriptions of hydroperiods).</p> <table border="0"> <tr> <td><input type="checkbox"/> Permanently flooded or inundated</td> <td>4 or more types present</td> <td>points = 3</td> <td><input type="checkbox"/></td> </tr> <tr> <td><input checked="" type="checkbox"/> Seasonally flooded or inundated</td> <td>3 or more types present</td> <td>points = 2</td> <td><input checked="" type="checkbox"/></td> </tr> <tr> <td><input checked="" type="checkbox"/> Occasionally flooded or inundated</td> <td>2 types present</td> <td>points = 1</td> <td><input type="checkbox"/></td> </tr> <tr> <td><input checked="" type="checkbox"/> Saturated only</td> <td>1 type present</td> <td>points = 0</td> <td><input type="checkbox"/></td> </tr> </table> <p><input checked="" type="checkbox"/> Permanently flowing stream or river in, or adjacent to, the wetland <input type="checkbox"/> Seasonally flowing stream in, or adjacent to, the wetland <input type="checkbox"/> Lake-fringe wetland..... = 2 points <input type="checkbox"/> Freshwater tidal wetland..... = 2 points</p> <p style="text-align: right;">Map of hydroperiods</p>	<input type="checkbox"/> Permanently flooded or inundated	4 or more types present	points = 3	<input type="checkbox"/>	<input checked="" type="checkbox"/> Seasonally flooded or inundated	3 or more types present	points = 2	<input checked="" type="checkbox"/>	<input checked="" type="checkbox"/> Occasionally flooded or inundated	2 types present	points = 1	<input type="checkbox"/>	<input checked="" type="checkbox"/> Saturated only	1 type present	points = 0	<input type="checkbox"/>	<p>Figure <input type="checkbox"/></p> <p>2</p>
<input type="checkbox"/> Permanently flooded or inundated	4 or more types present	points = 3	<input type="checkbox"/>															
<input checked="" type="checkbox"/> Seasonally flooded or inundated	3 or more types present	points = 2	<input checked="" type="checkbox"/>															
<input checked="" type="checkbox"/> Occasionally flooded or inundated	2 types present	points = 1	<input type="checkbox"/>															
<input checked="" type="checkbox"/> Saturated only	1 type present	points = 0	<input type="checkbox"/>															
H 1.3	<p>Richness of Plant Species (see p. 75): Count the number of plant species in the wetland that cover at least 10 ft² (different patches of the same species can be combined to meet the size threshold) You do not have to name the species. Do not include Eurasian Milfoil, reed canarygrass, purple loosestrife, Canadian Thistle. If you counted: > 19 species points = 2 <input type="checkbox"/> 5 – 19 species..... points = 1 <input checked="" type="checkbox"/> < 5 species points = 0 <input type="checkbox"/></p> <p>List species below if you want to:</p>	<p>1</p>																
H 1.4	<p>Interspersion of Habitats (see p. 76): Decided from the diagrams below whether interspersion between Cowardin vegetation (described in H1.1), or the classes and unvegetated areas (can include open water or mudflats) is high, medium, low, or none.</p> <div style="text-align: center;"> <p>None = 0 points Low = 1 point Moderate = 2 points</p> <p>High = 3 points [riparian braided channels]</p> </div> <p>Note: If you have 4 or more classes or 3 vegetation classes and open water, the rating is always “high”. Use map of Cowardin classes.</p>	<p>Figure <input type="checkbox"/></p> <p>3</p>																
H 1.5	<p>Special Habitat Features (see p. 77): Check the habitat features that are present in the wetland. The number of checks is the number of points you put into the next column.</p> <p><input checked="" type="checkbox"/> Large, downed, woody debris within the wetland (> 4 in. diameter and 6 ft. long) <input checked="" type="checkbox"/> Standing snags (diameter at the bottom > 4 inches) in the wetland <input type="checkbox"/> Undercut banks are present for at least 6.6 ft. (2m) and/or overhanging vegetation extends at least 3.3 ft. (1m) over a stream (or ditch) in, or contiguous with the unit, for at least 33 ft. (10m) <input type="checkbox"/> Stable steep banks of fine material that might be used by beaver or muskrat for denning (> 30 degree slope) OR signs of recent beaver activity are present (cut shrubs or trees that have not yet turned grey/brown) <input type="checkbox"/> At least 1/4 acre of thin-stemmed persistent vegetation or woody branches are present in areas that are permanently or seasonally inundated (structures for egg-laying by amphibians) <input type="checkbox"/> Invasive plants cover less than 25% of the wetland area in each stratum of plants NOTE: The 20% stated in early printings of the manual on page 78 is an error.</p>	<p>2</p>																
H 1 TOTAL Score – potential for providing habitat		<p>Add the points in the column above</p> <p>9</p>																

H 2	Does the wetland have the <u>opportunity</u> to provide habitat for many species?	(only 1 score per box)
	<p>H 2.1 <u>Buffers</u> (see P. 80): Choose the description that best represents condition of buffer of wetland unit. The highest scoring criterion that applies to the wetland is to be used in the rating. See text for definition of "undisturbed".</p> <p><input type="checkbox"/> 100m (330 ft) of relatively undisturbed vegetated areas, rocky areas, or open water > 95% of circumference. No structures are within the undisturbed part of buffer (relatively undisturbed also means no grazing, no landscaping, no daily human use)..... points = 5</p> <p><input type="checkbox"/> 100m (330 ft) of relatively undisturbed vegetated areas, rocky areas, or open water > 50% circumference points = 4</p> <p><input type="checkbox"/> 50m (170 ft) of relatively undisturbed vegetated areas, rocky areas, or open water > 95% circumference points = 4</p> <p><input type="checkbox"/> 100m (330 ft) of relatively undisturbed vegetated areas, rocky areas, or open water > 25% circumference points = 3</p> <p><input type="checkbox"/> 50m (170 ft) of relatively undisturbed vegetated areas, rocky areas, or open water for > 50% circumference points = 3</p> <p>If buffer does not meet any of the criteria above:</p> <p><input type="checkbox"/> No paved areas (except paved trails) or buildings within 25m (80 ft) of wetland > 95% circumference. Light to moderate grazing or lawns are OK points = 2</p> <p><input type="checkbox"/> No paved areas of buildings within 50m of wetland for > 50% circumference. Light to moderate grazing or lawns are OK points = 2</p> <p><input type="checkbox"/> Heavy grazing in buffer points = 1</p> <p><input type="checkbox"/> Vegetated buffers are < 2m wide (6.6 ft) for more than 95% circumference (e.g. tilled fields, paving, basalt bedrock extend to edge of wetland) points = 0</p> <p><input checked="" type="checkbox"/> Buffer does not meet any of the criteria above points = 1</p> <p style="text-align: right;">Arial photo showing buffers</p>	<p>Figure <input type="checkbox"/></p> <p style="text-align: center;">1</p>
	<p>H 2.2 <u>Corridors and Connections</u> (see p. 81)</p> <p>H 2.2.1 Is the wetland part of a relatively undisturbed and unbroken vegetated corridor (either riparian or upland) that is at least 150 ft. wide, has at least a 30% cover of shrubs, forest or native undisturbed prairie, that connects to estuaries, other wetlands or undisturbed uplands that are at least 250 acres in size? (<i>Dams in riparian corridors, heavily used gravel roads, paved roads, are considered breaks in the corridor.</i>)</p> <p style="padding-left: 40px;"><input type="checkbox"/> YES = 4 points (go to H 2.3) <input checked="" type="checkbox"/> NO = go to H 2.2.2</p> <p>H. 2.2.2 Is the wetland part of a relatively undisturbed and unbroken vegetated corridor (either riparian or upland) that is at least 50 ft. wide, has at least 30% cover of shrubs or forest, and connects to estuaries, other wetlands or undisturbed uplands that are at least 25 acres in size? OR a Lake-fringe wetland, if it does not have an undisturbed corridor as in the question above?</p> <p style="padding-left: 40px;"><input type="checkbox"/> YES = 2 points (go to H 2.3) <input checked="" type="checkbox"/> NO = go to H 2.2.3</p> <p>H. 2.2.3 Is the wetland:</p> <ul style="list-style-type: none"> • Within 5 mi (8km) of a brackish or salt water estuary OR • Within 3 miles of a large field or pasture (> 40 acres) OR • Within 1 mile of a lake greater than 20 acres? <p style="text-align: right; padding-right: 40px;"><input checked="" type="checkbox"/> YES = 1 point <input type="checkbox"/> NO = 0 points</p>	<p style="text-align: center;">1</p>

Comments: _____

	<p>H 2.3 <u>Near or adjacent to other priority habitats listed by WDFW</u> (see p. 82): (see new and complete descriptions of WDFW priority habitats, and the counties in which they can be found, in the PHS report http://wdfw.wa.gov/hab/phslist.htm)</p> <p>Which of the following priority habitats are within 330 ft. (100m) of the wetland unit? NOTE: the connections do not have to be relatively undisturbed.</p> <p><input type="checkbox"/> Aspen Stands: Pure or mixed stands of aspen greater than 0.4 ha (1 acre).</p> <p><input type="checkbox"/> Biodiversity Areas and Corridors: Areas of habitat that are relatively important to various species of native fish and wildlife (full descriptions in WDFW PHS report p. 152).</p> <p><input type="checkbox"/> Herbaceous Balds: Variable size patches of grass and forbs on shallow soils over bedrock.</p> <p><input type="checkbox"/> Old-growth/Mature forests: (Old-growth west of Cascade crest) Stands of at least 2 tree species, forming a multi-layered canopy with occasional small openings; with at least 20 trees/ha (8 trees/acre) > 81 cm (32 in) dbh or > 200 years of age. (Mature forests) Stands with average diameters exceeding 53 cm (21 in) dbh; crown cover may be less than 100%; decay, decadence, numbers of snags, and quantity of large downed material is generally less than that found in old-growth; 80 - 200 years old west of the Cascade crest.</p> <p><input type="checkbox"/> Oregon white Oak: Woodlands Stands of pure oak or oak/conifer associations where canopy coverage of the oak component is important (full descriptions in WDFW PHS report p. 158).</p> <p><input checked="" type="checkbox"/> Riparian: The area adjacent to aquatic systems with flowing water that contains elements of both aquatic and terrestrial ecosystems which mutually influence each other.</p> <p><input type="checkbox"/> Westside Prairies: Herbaceous, non-forested plant communities that can either take the form of a dry prairie or a wet prairie (full descriptions in WDFW PHS report p. 161).</p> <p><input checked="" type="checkbox"/> Instream: The combination of physical, biological, and chemical processes and conditions that interact to provide functional life history requirements for instream fish and wildlife resources.</p> <p><input type="checkbox"/> Nearshore: Relatively undisturbed nearshore habitats. These include Coastal Nearshore, Open Coast Nearshore, and Puget Sound Nearshore. (full descriptions of habitats and the definition of relatively undisturbed are in WDFW report: pp. 167-169 and glossary in Appendix A).</p> <p><input type="checkbox"/> Caves: A naturally occurring cavity, recess, void, or system of interconnected passages under the earth in soils, rock, ice, or other geological formations and is large enough to contain a human.</p> <p><input type="checkbox"/> Cliffs: Greater than 7.6 m (25 ft) high and occurring below 5000 ft.</p> <p><input type="checkbox"/> Talus: Homogenous areas of rock rubble ranging in average size 0.15 - 2.0 m (0.5 - 6.5 ft), composed of basalt, andesite, and/or sedimentary rock, including riprap slides and mine tailings. May be associated with cliffs.</p> <p><input type="checkbox"/> Snags and Logs: Trees are considered snags if they are dead or dying and exhibit sufficient decay characteristics to enable cavity excavation/use by wildlife. Priority snags have a diameter at breast height of > 51 cm (20 in) in western Washington and are > 2 m (6.5 ft) in height. Priority logs are > 30 cm (12 in) in diameter at the largest end, and > 6 m (20 ft) long.</p> <p style="text-align: right;">If wetland has 3 or more priority habitats = 4 points If wetland has 2 priority habitats = 3 points If wetland has 1 priority habitat = 1 point No habitats = 0 points</p> <p>Note: All vegetated wetlands are by definition a priority habitat but are not included in this list. Nearby wetlands are addressed in question H 2.4)</p>	3
	<p>H 2.4 <u>Wetland Landscape:</u> Choose the one description of the landscape around the wetland that best fits (see p. 84)</p> <ul style="list-style-type: none"> • There are at least 3 other wetlands within 1/2 mile, and the connections between them are relatively undisturbed (light grazing between wetlands OK, as is lake shore with some boating, but connections should NOT be bisected by paved roads, fill, fields, or other development.... points = 5 <input type="checkbox"/> • The wetland is Lake-fringe on a lake with little disturbance and there are 3 other lake-fringe wetlands within 1/2 mile points = 5 <input type="checkbox"/> • There are at least 3 other wetlands within 1/2 mile, BUT the connections between them are disturbed. points = 3 <input checked="" type="checkbox"/> • The wetland fringe on a lake with disturbance and there are 3 other lake-fringe wetlands within 1/2 mile points = 3 <input type="checkbox"/> • There is at least 1 wetland within 1/2 mile points = 2 <input type="checkbox"/> • There are no wetlands within 1/2 mile..... points = 0 <input type="checkbox"/> 	3
H 2 TOTAL Score – opportunity for providing habitat Add the scores from H2.1, H2.2, H2.3, H2.4		8
TOTAL for H 1 from page 8		9
◆	Total Score for Habitat Functions Add the points for H 1 and H 2; then record the result on p. 1	17

Comments: _____

CATEGORIZATION BASED ON SPECIAL CHARACTERISTICS

Please determine if the wetland meets the attributes described below and circle the appropriate answers and Category.

Wetland Type – Check off any criteria that apply to the wetland. Circle the Category when the appropriate criteria are met.	
SC1	<p>Estuarine wetlands? (see p.86)</p> <p>Does the wetland unit meet the following criteria for Estuarine wetlands?</p> <p><input type="checkbox"/> The dominant water regime is tidal, <input type="checkbox"/> Vegetated, and <input type="checkbox"/> With a salinity greater than 0.5 ppt.</p> <p style="text-align: center;"><input type="checkbox"/> YES = Go to SC 1.1 <input checked="" type="checkbox"/> NO</p>
	<p>SC 1.1 Is the wetland unit within a National Wildlife Refuge, National Park, National Estuary Reserve, Natural Area Preserve, State Park or Educational, Environmental, or Scientific Reserve designated under WAC 332-30-151? <input type="checkbox"/> YES = Category I <input type="checkbox"/> NO = go to SC 1.2</p>
	<p>SC 1.2 Is the wetland at least 1 acre in size and meets at least two of the following conditions?</p> <p style="text-align: center;"><input type="checkbox"/> YES = Category I <input type="checkbox"/> NO = Category II</p> <p><input type="checkbox"/> The wetland is relatively undisturbed (has no diking, ditching, filling, cultivation, grazing, and has less than 10% cover of non-native plant species. If the non-native <i>Spartina</i> spp. are only species that cover more than 10% of the wetland, then the wetland should be given a dual rating (I/II). The area of <i>Spartina</i> would be rated a Category II while the relatively undisturbed upper marsh with native species would be a Category I. Do not, however, exclude the area of <i>Spartina</i> in determining the size threshold of 1 acre.</p> <p><input type="checkbox"/> At least 3/4 of the landward edge of the wetland has a 100 ft. buffer of shrub, forest, or un-grazed or un-mowed grassland</p> <p><input type="checkbox"/> The wetland has at least 2 of the following features: tidal channels, depressions with open water, or contiguous freshwater wetlands.</p>
SC2	<p>Natural Heritage Wetlands (see p. 87)</p> <p>Natural Heritage wetlands have been identified by the Washington Natural Heritage Program/DNR as either high quality undisturbed wetlands or wetlands that support state Threatened, Endangered, or Sensitive plant species.</p> <p>SC 2.1 Is the wetland being rated in a Section/Township/Range that contains a natural heritage wetland? (This question is used to screen out most sites before you need to contact WNHP/DNR.)</p> <p style="text-align: center;"><input type="checkbox"/> S/T/R information from Appendix D <input type="checkbox"/> or accessed from WNHP/DNR web site <input type="checkbox"/> YES Contact WNHP/DNR (see p. 79) and go to SC 2.2 <input checked="" type="checkbox"/> NO</p> <p>SC 2.2 Has DNR identified the wetland as a high quality undisturbed wetland or as a site with state threatened or endangered plant species?</p> <p style="text-align: center;"><input type="checkbox"/> YES = Category 1 <input checked="" type="checkbox"/> NO not a Heritage Wetland</p>
SC3	<p>Bogs (see p. 87)</p> <p>Does the wetland (or any part of the unit) meet both the criteria for soils and vegetation in bogs? Use the key below to identify if the wetland is a bog. If you answer yes you will still need to rate the wetland based on its function.</p> <ol style="list-style-type: none"> Does the unit have organic soil horizons (i.e. layers of organic soil), either peats or mucks, that compose 16 inches or more of the first 32 inches of soil profile? (See Appendix B for a field key to identify organic soils)? <input type="checkbox"/> YES = go to question 3 <input checked="" type="checkbox"/> NO = go to question 2 Does the wetland have organic soils, either peats or mucks that are less than 16 inches deep over bedrock, or an impermeable hardpan such as clay or volcanic ash, or that are floating on a lake or pond? <input type="checkbox"/> YES = go to question 3 <input checked="" type="checkbox"/> NO = is not a bog for purpose of rating Does the unit have more than 70% cover of mosses at ground level, AND other plants, if present, consist of the “bog” species listed in Table 3 as a significant component of the vegetation (more than 30% of the total shrub and herbaceous cover consists of species in Table 3)? <p style="text-align: center;"><input type="checkbox"/> YES = Is a bog for purpose of rating <input checked="" type="checkbox"/> NO = go to question 4</p> <p>NOTE: If you are uncertain about the extent of mosses in the understory you may substitute that criterion by measuring the pH of the water that seeps into a hole dug at least 16” deep. If the pH is less than 5.0 and the “bog” plant species in Table 3 are present, the wetland is a bog.</p> <ol style="list-style-type: none"> Is the unit forested (> 30% cover) with sitka spruce, subalpine fir, western red cedar, western hemlock, lodgepole pine, quaking aspen, Englemann’s spruce, or western white pine. WITH any of the species (or combination of species) on the bog species plant list in Table 3 as a significant component of the ground cover (> 30% coverage of the total shrub/herbaceous cover)? <p style="text-align: center;"><input type="checkbox"/> YES = Category I <input checked="" type="checkbox"/> NO = Is not a bog for purpose of rating</p>

SC4	<p>Forested Wetlands (see p. 90)</p> <p>Does the wetland have at least 1 acre of forest that meet one of these criteria for the Department of Fish and Wildlife's forests as priority habitats? <i>If you answer yes you will still need to rate the wetland based on its function.</i></p> <p><input type="checkbox"/> Old-growth forests: (west of Cascade Crest) Stands of at least two three species forming a multi-layered canopy with occasional small openings; with at least 8 trees/acre (20 trees/hectare) that are at least 200 years of age OR have a diameter at breast height (dbh) of 32 inches (81 cm or more). NOTE: The criterion for dbh is based on measurements for upland forests. Two-hundred year old trees in wetlands will often have a smaller dbh because their growth rates are often slower. The DFW criterion is and "OR" so old-growth forests do not necessarily have to have trees of this diameter.</p> <p><input type="checkbox"/> Mature forests: (west of the Cascade Crest) Stands where the largest trees are 80 – 200 years old OR have an average diameters (dbh) exceeding 21 inches (53 cm); crown cover may be less than 100%; decay, decadence, numbers of snags, and quantity of large downed material is generally less than that found in old-growth.</p> <p><input type="checkbox"/> YES = Category I <input checked="" type="checkbox"/> NO = not a forested wetland with special characteristics</p>	<p>Cat. I <input type="checkbox"/></p>
SC5	<p>Wetlands in Coastal Lagoons (see p. 91)</p> <p>Does the wetland meet all of the following criteria of a wetland in a coastal lagoon?</p> <p><input type="checkbox"/> The wetland lies in a depression adjacent to marine waters that is wholly or partially separated from marine waters by sandbanks, gravel banks, shingle, or, less frequently, rocks.</p> <p><input type="checkbox"/> The lagoon in which the wetland is located contains surface water that is saline or brackish (> 0.5 ppt) during most of the year in at least a portion of the lagoon (<i>needs to be measured near the bottom.</i>)</p> <p><input type="checkbox"/> YES = Go to SC 5.1 <input checked="" type="checkbox"/> NO not a wetland in a coastal lagoon</p> <p>SC 5.1 Does the wetland meet all of the following three conditions?</p> <p><input type="checkbox"/> The wetland is relatively undisturbed (has no diking, ditching, filling, cultivation, grazing) and has less than 20% cover of invasive plant species (see list of invasive species on p. 74).</p> <p><input type="checkbox"/> At least 3/4 of the landward edge of the wetland has a 100 ft. buffer of shrub, forest, or un-grazed or un-mowed grassland.</p> <p><input type="checkbox"/> The wetland is larger than 1/10 acre (4350 square ft.)</p> <p><input type="checkbox"/> YES = Category I <input type="checkbox"/> NO = Category II</p>	<p style="background-color: #cccccc;">Cat. I <input type="checkbox"/></p> <p>Cat. II <input type="checkbox"/></p>
SC6	<p>Interdunal Wetlands (see p. 93)</p> <p>Is the wetland west of the 1889 line (also called the Western Boundary of Upland Ownership or WBUO)?</p> <p><input type="checkbox"/> YES = Go to SC 6.1 <input checked="" type="checkbox"/> NO not an interdunal wetland for rating</p> <p><i>If you answer yes you will still need to rate the wetland based on its functions.</i></p> <p>In practical terms that means the following geographic areas:</p> <ul style="list-style-type: none"> • Long Beach Peninsula -- lands west of SR 103 • Grayland-Westport -- lands west of SR 105 • Ocean Shores-Copalis – lands west of SR 115 and SR 109 <p>SC 6.1 Is the wetland one acre or larger, or is it in a mosaic of wetlands that is one acre or larger?</p> <p><input type="checkbox"/> YES = Category II <input type="checkbox"/> NO = go to SC 6.2</p> <p>SC 6.2 Is the wetland between 0.1 and 1 acre, or is it in a mosaic of wetlands that is between 0.1 and 1 acre?</p> <p><input type="checkbox"/> YES = Category III</p>	<p>Cat. II <input type="checkbox"/></p> <p>Cat. III <input type="checkbox"/></p>
◆	<p>Category of wetland based on Special Characteristics</p> <p><i>Choose the "highest" rating if wetland falls into several categories, and record on p. 1.</i></p> <p>If you answered NO for all types enter "Not Applicable" on p. 1</p>	<p>NA</p>

Comments:

WETLAND RATING FORM – WESTERN WASHINGTON
Version 2 – Updated July 2006 to increase accuracy and reproducibility among users
Updated Oct. 2008 with the new WDFW definitions for priority habitats

Name of wetland (if known): Bellefield South

Date of site visit: May 17, 2013

Rated by: C. Douglas & J. Pursley Trained by Ecology? Yes No

Date of training: May 2007

SEC: 5 TOWNSHP: 24N RNGE: 5E

Is S/T/R in Appendix D? Yes No

Map of wetland unit: Figure _____ Estimated size _____

SUMMARY OF RATING

Category based on FUNCTIONS provided by wetland: I II III IV

Category I =	Score > 70
Category II =	Score 51 - 69
Category III =	Score 30 – 50
Category IV =	Score < 30

Score for Water Quality Functions	20
Score for Hydrologic Functions	16
Score for Habitat Functions	18
TOTAL Score for Functions	54

Category based on SPECIAL CHARACTERISTICS of Wetland I II Does not apply

Final Category (choose the “highest” category from above”)

II

Summary of basic information about the wetland unit.

Wetland Unit has Special Characteristics		Wetland HGM Class used for Rating	
Estuarine	<input type="checkbox"/>	Depressional	<input type="checkbox"/>
Natural Heritage Wetland	<input type="checkbox"/>	Riverine	<input checked="" type="checkbox"/>
Bog	<input type="checkbox"/>	Lake-fringe	<input type="checkbox"/>
Mature Forest	<input type="checkbox"/>	Slope	<input checked="" type="checkbox"/>
Old Growth Forest	<input type="checkbox"/>	Flats	<input type="checkbox"/>
Coastal Lagoon	<input type="checkbox"/>	Freshwater Tidal	<input type="checkbox"/>
Interdunal	<input type="checkbox"/>		<input type="checkbox"/>
None of the above	<input checked="" type="checkbox"/>	Check if unit has multiple HGM classes present	<input checked="" type="checkbox"/>

Does the wetland being rated meet any of the criteria below? If you answer YES to any of the questions below you will need to protect the wetland according to the regulations regarding the special characteristics found in the wetland.

Check List for Wetlands that Need Additional Protection (in addition to the protection recommended for its category)	YES	NO
SP1. <i>Has the wetland unit been documented as a habitat for any Federally listed Threatened or Endangered animal or plant species (T/E species)?</i> For the purposes of this rating system, “documented” means the wetland is on the appropriate state or federal database.	<input checked="" type="checkbox"/>	<input type="checkbox"/>
SP2. <i>Has the wetland unit been documented as habitat for any State listed Threatened or Endangered animal species?</i> For the purposes of this rating system, “documented” means the wetland is on the appropriate state database. Note: Wetlands with State listed plant species are categorized as Category 1 Natural Heritage Wetlands (see p. 19 of data form).	<input checked="" type="checkbox"/>	<input type="checkbox"/>
SP3. <i>Does the wetland unit contain individuals of Priority species listed by the WDFW for the state?</i>	<input checked="" type="checkbox"/>	<input type="checkbox"/>
SP4. <i>Does the wetland unit have a local significance in addition to its functions?</i> For example, the wetland has been identified in the Shoreline Master Program, the Critical Areas Ordinance, or in a local management plan as having special significance.	<input type="checkbox"/>	<input checked="" type="checkbox"/>

To complete the next part of the data sheet you will need to determine the Hydrogeomorphic Class of the wetland being rated.

The hydrogeomorphic classification groups wetlands in to those that function in similar ways. This simplifies the questions needed to answer how well the wetland functions. The Hydrogeomorphic Class of a wetland can be determined using the key below. See p. 24 for more detailed instructions on classifying wetlands.

Classification of Vegetated Wetlands for Western Washington

If the hydrologic criteria listed in each question do not apply to the entire unit being rated, you probably have a unit with multiple HGM classes. In this case, identify which hydrologic criteria in questions 1-7 apply, and go to Question 8.

1. Are the water levels in the entire unit usually controlled by tides (i.e. except during floods)?
 NO – go to 2 YES – the wetland class is **Tidal Fringe**
 If yes, is the salinity of the water during periods of annual low flow below 0.5 ppt (parts per thousand)?
 YES – **Freshwater Tidal Fringe** NO – **Saltwater Tidal Fringe (Estuarine)**
*If your wetland can be classified as a Freshwater Tidal Fringe use the forms for **Riverine** wetlands. If it is a Saltwater Tidal Fringe it is rated as an **Estuarine** wetland. Wetlands that were call estuarine in the first and second editions of the rating system are called Salt Water Tidal Fringe in the Hydrogeomorphic Classification. Estuarine wetlands were categorized separately in the earlier editions, and this separation is being kept in this revision. To maintain consistency between editions, the term “Estuarine” wetland is kept. Please note, however, that the characteristics that define Category I and II estuarine wetlands have changed (see p. _____).*
-
2. The entire wetland unit is flat and precipitation is only source (>90%) of water to it. Groundwater and surface water runoff are NOT sources of water to the unit.
 NO – go to 3 YES – The wetland class is **Flats**
 If your wetland can be classified as a “Flats” wetland, use the form for **Depressional** wetlands.
-
3. Does the entire wetland meet both of the following criteria?
 The vegetated part of the wetland is on the shores of a body of permanent open water (without any vegetation on the surface) where at least 20 acres (8ha) in size;
 At least 30% of the open water area is deeper than 6.6 (2 m)?
 NO – go to 4 YES – The wetland class is **Lake-fringe (Lacustrine Fringe)**
-
4. Does the entire wetland meet all of the following criteria?
 The wetland is on a slope (*slope can be very gradual*).
 The water flows through the wetland in one direction (unidirectional) and usually comes from seeps. It may flow subsurface, as sheetflow, or in a swale without distinct banks.
 The water leaves the wetland **without being impounded**?
 NOTE: *Surface water does not pond in these types of wetlands except occasionally in very small and shallow depressions or behind hummocks (depressions are usually <3 ft diameter and less than 1 foot deep).*
 NO – go to 5 YES – The wetland class is **Slope**
-
5. Does the entire wetland meet all of the following criteria?
 The unit is in a valley or stream channel where it gets inundated by overbank flooding from that stream or river.
 The overbank flooding occurs at least once every two years.
 NOTE: *The riverine unit can contain depressions that are filled with water when the river is not flooding..*
 NO – go to 6 YES – The wetland class is **Riverine**
-
6. Is the entire wetland unit in a topographic depression in which water ponds, or is saturated to the surface, at some time of the year. This means that any outlet, if present is higher than the interior of the wetland.
 NO – go to 7 YES – The wetland class is **Depressional**
-
7. Is the entire wetland located in a very flat area with no obvious depression and no overbank flooding. The unit does not pond surface water more than a few inches. The unit seems to be maintained by high groundwater in the area. The wetland may be ditched, but has no obvious natural outlet.
 No – go to 8 YES – The wetland class is **Depressional**
-
8. Your wetland unit seems to be difficult to classify and probably contains several different HGM classes. For example, seeps at the base of a slope may grade into a riverine floodplain, or a small stream within a depressional wetland has a zone of flooding along its sides. GO BACK AND IDENTIFY WHICH OF THE HYDROLOGIC REGIMES DESCRIBED IN QUESTIONS 1-7 APPLY TO DIFFERENT AREAS IN THE UNIT (make a rough sketch to help you decide). Use the following table to identify the appropriate class to use for the rating system if you have several HGM classes present within your wetland. NOTE: Use this table only if the class that is recommended in the second column represents 10% or more of the total area of the wetland unit being rated. If the area of the class listed in column 2 is less than 10% of the unit, classify the wetland using the class that represents more than 90% of the total area.

HGM Classes within the wetland unit being rated	HGM Class to Use in Rating
Slope + Riverine	Riverine
Slope + Depressional	Depressional
Slope + Lake-fringe	Lake-fringe
Depressional + Riverine along stream within boundary	Depressional
Depressional + Lake-fringe	Depressional
Salt Water Tidal Fringe and any other class of freshwater wetland	Treat as ESTUARINE under wetlands with special characteristics

If you are unable still to determine which of the above criteria apply to your wetland, or you have more than 2 HGM classes within a wetland boundary, classify the wetland as **Depressional** for the rating.

R Riverine and Freshwater Tidal Fringe Wetlands		Points
WATER QUALITY FUNCTIONS – Indicators that wetland functions to improve water quality.		(only 1 score per box)
R 1	Does the wetland have the <u>potential</u> to improve water quality? (see p.52)	
	R 1.1 Area of surface depressions within the riverine wetland that can trap sediments during a flooding event: <ul style="list-style-type: none"> • Depressions cover > 3/4 area of wetland points = 8 <input type="checkbox"/> • Depressions cover > 1/2 area of wetland points = 4 <input type="checkbox"/> (If depressions > 1/2 of area of unit draw polygons on aerial photo or map) • Depressions present but cover < 1/2 area of wetland. points = 2 <input checked="" type="checkbox"/> • No depressions present points = 0 <input type="checkbox"/> 	Figure <input type="checkbox"/> 2
	R 1.2 Characteristics of the vegetation in the unit (areas with >90% cover at person height): <ul style="list-style-type: none"> • Trees or shrubs > 2/3 area of the unit points = 8 <input checked="" type="checkbox"/> • Trees or shrubs > 1/3 area of the wetland points = 6 <input type="checkbox"/> • Ungrazed, herbaceous plants > 2/3 area of unit points = 6 <input type="checkbox"/> • Ungrazed herbaceous plants > 1/3 area of unit points = 3 <input type="checkbox"/> • Trees, shrubs, and ungrazed herbaceous < 1/3 area of unit points = 0 <input type="checkbox"/> 	Figure <input type="checkbox"/> 8
Aerial photo or map showing polygons of different vegetation types		
Add the points in the boxes above		10
R 2	Does the wetland have the <u>opportunity</u> to improve water quality?	(see p. 53)
	Answer YES if you know or believe there are pollutants in groundwater or surface water coming into the wetland that would otherwise reduce water quality in streams, lakes or groundwater downgradient from the wetland. <i>Note which of the following conditions provide the sources of pollutants. A unit may have pollutants coming from several sources, but any single source would qualify as opportunity.</i> <ul style="list-style-type: none"> <input type="checkbox"/> Grazing in the wetland or within 150 ft <input checked="" type="checkbox"/> Untreated stormwater discharges to wetland <input type="checkbox"/> Tilled fields or orchards within 150 ft. of wetland <input type="checkbox"/> A stream or culvert discharges into wetland that drains developed areas, residential areas, farmed fields, roads, or clear-cut logging <input checked="" type="checkbox"/> Residential, urban areas, golf courses are within 150 ft. of wetland <input type="checkbox"/> The river or stream linked to the wetland has a contributing basin where human activities have raised levels of sediment, toxic compounds or nutrients in the river water above standards for water quality. <input type="checkbox"/> Other _____ 	Multiplier 2
YES multiplier is 2 NO multiplier is 1		
◆ TOTAL – Water Quality Functions Multiply the score from R1 by R2; then <i>add score to table on p. 1</i>		20
HYDROLOGIC FUNCTIONS – Indicators that wetland functions to reduce flooding and stream erosion.		
R 3	Does the wetland have the <u>potential</u> to reduce flooding and erosion?	(see p.54)
	R 3.1 Characteristics of the overbank storage the wetland provides: <i>Estimate the average width of the wetland perpendicular to the direction of the flow and the width of the stream or river channel (distance between banks). Calculate the ratio: (average width of unit) / (average width of stream between banks).</i> <ul style="list-style-type: none"> • If the ratio is more than 20 points = 9 <input type="checkbox"/> • If the ratio is between 10 – 20 points = 6 <input type="checkbox"/> • If the ratio is 5- <10 points = 4 <input type="checkbox"/> • If the ratio is 1- <5 points = 2 <input type="checkbox"/> • If the ratio is < 1 points = 1 <input checked="" type="checkbox"/> 	Figure <input type="checkbox"/> 1
	R 3.2 Characteristics of vegetation that slow down water velocities during floods: <i>Treat large woody debris as “forest or shrub”. Choose the points appropriate for the best description. (polygons need to have >90% cover at person height NOT Cowardin classes):</i> <ul style="list-style-type: none"> • Forest or shrub for > 1/3 area OR herbaceous plants > 2/3 area points = 7 <input checked="" type="checkbox"/> • Forest or shrub for > 1/10 area OR herbaceous plants > 1/3 area points = 4 <input type="checkbox"/> • Vegetation does not meet above criteria points = 0 <input type="checkbox"/> 	Figure <input type="checkbox"/> 7
Aerial photo or map showing polygons of different vegetation types		
Add the points in the boxes above		8
R 4	Does the wetland have the <u>opportunity</u> to reduce flooding and erosion?	(see p.57)
	Answer YES if the wetland is in a location in the watershed where the flood storage, or reduction in water velocity, it provides helps protect downstream property and aquatic resources from flooding or excessive and/or erosive flows. <i>Note which of the following conditions apply.</i> <ul style="list-style-type: none"> <input checked="" type="checkbox"/> There are human structures and activities downstream (roads, buildings, bridges, farms) that can be damaged by flooding. <input checked="" type="checkbox"/> There are natural resources downstream (e.g. salmon redds) that can be damaged by flooding <input type="checkbox"/> Other _____ 	Multiplier 2
(Answer NO if the major source of water to the wetland is controlled by a reservoir or the wetland is tidal fringe along the sides of a dike)		
<input checked="" type="checkbox"/> YES multiplier is 2 <input type="checkbox"/> NO multiplier is 1		
◆ TOTAL – Hydrologic Functions Multiply the score from R3 by R4; then <i>add score to table on p. 1</i>		16

Comments: _____

<i>These questions apply to wetlands of all HGM classes.</i>		Points												
HABITAT FUNCTIONS – Indicators that wetland functions to provide important habitat.		(only 1 score per box)												
H 1	Does the wetland have the potential to provide habitat for many species?													
H 1.1	<p><u>Vegetation structure</u> (see P. 72): Check the types of vegetation classes present (as defined by Cowardin) – Size threshold for each class is 1/4 acre or more than 10% of the area if unit is smaller than 2.5 acres.</p> <p><input type="checkbox"/> Aquatic Bed <input checked="" type="checkbox"/> Emergent plants <input checked="" type="checkbox"/> Scrub/shrub (areas where shrubs have > 30% cover) <input checked="" type="checkbox"/> Forested (areas where trees have > 30% cover)</p> <p>If the unit has a forested class check if: <input type="checkbox"/> The forested class has 3 out of 5 strata (canopy, sub-canopy, shrubs, herbaceous, moss/ground-cover) that each cover 20% within the forested polygon.</p> <p>Add the number of vegetation types that qualify. If you have:</p> <table style="width: 100%;"> <tr> <td>4 structures or more..... points = 4</td> <td><input type="checkbox"/></td> <td>Map of Cowardin vegetation classes</td> <td></td> </tr> <tr> <td>3 structures..... points = 2</td> <td><input checked="" type="checkbox"/></td> <td>3 structures..... points = 2</td> <td><input checked="" type="checkbox"/></td> </tr> <tr> <td>2 structures..... points = 1</td> <td><input type="checkbox"/></td> <td>1 structure..... points = 0</td> <td><input type="checkbox"/></td> </tr> </table>	4 structures or more..... points = 4	<input type="checkbox"/>	Map of Cowardin vegetation classes		3 structures..... points = 2	<input checked="" type="checkbox"/>	3 structures..... points = 2	<input checked="" type="checkbox"/>	2 structures..... points = 1	<input type="checkbox"/>	1 structure..... points = 0	<input type="checkbox"/>	<p>Figure <input type="checkbox"/></p> <p style="text-align: right;">2</p>
4 structures or more..... points = 4	<input type="checkbox"/>	Map of Cowardin vegetation classes												
3 structures..... points = 2	<input checked="" type="checkbox"/>	3 structures..... points = 2	<input checked="" type="checkbox"/>											
2 structures..... points = 1	<input type="checkbox"/>	1 structure..... points = 0	<input type="checkbox"/>											
H 1.2	<p><u>Hydroperiods</u> (see p.73): Check the types of water regimes (hydroperiods) present within the wetland. The water regime has to cover more than 10% of the wetland or 1/4 acre to count (see text for descriptions of hydroperiods).</p> <p><input type="checkbox"/> Permanently flooded or inundated <input checked="" type="checkbox"/> Seasonally flooded or inundated <input checked="" type="checkbox"/> Occasionally flooded or inundated <input checked="" type="checkbox"/> Saturated only <input checked="" type="checkbox"/> Permanently flowing stream or river in, or adjacent to, the wetland <input type="checkbox"/> Seasonally flowing stream in, or adjacent to, the wetland</p> <p><input type="checkbox"/> Lake-fringe wetland..... = 2 points <input type="checkbox"/> Freshwater tidal wetland..... = 2 points</p> <table style="width: 100%;"> <tr> <td>4 or more types present</td> <td>points = 3</td> <td><input type="checkbox"/></td> </tr> <tr> <td>3 or more types present</td> <td>points = 2</td> <td><input checked="" type="checkbox"/></td> </tr> <tr> <td>2 types present</td> <td>points = 1</td> <td><input type="checkbox"/></td> </tr> <tr> <td>1 type present</td> <td>points = 0</td> <td><input type="checkbox"/></td> </tr> </table> <p style="text-align: right;">Map of hydroperiods</p>	4 or more types present	points = 3	<input type="checkbox"/>	3 or more types present	points = 2	<input checked="" type="checkbox"/>	2 types present	points = 1	<input type="checkbox"/>	1 type present	points = 0	<input type="checkbox"/>	<p>Figure <input type="checkbox"/></p> <p style="text-align: right;">2</p>
4 or more types present	points = 3	<input type="checkbox"/>												
3 or more types present	points = 2	<input checked="" type="checkbox"/>												
2 types present	points = 1	<input type="checkbox"/>												
1 type present	points = 0	<input type="checkbox"/>												
H 1.3	<p><u>Richness of Plant Species</u> (see p. 75): Count the number of plant species in the wetland that cover at least 10 ft² (different patches of the same species can be combined to meet the size threshold) You do not have to name the species. Do not include Eurasian Milfoil, reed canarygrass, purple loosestrife, Canadian Thistle.</p> <p>If you counted:</p> <table style="width: 100%;"> <tr> <td>> 19 species</td> <td>points = 2</td> <td><input type="checkbox"/></td> </tr> <tr> <td>5 – 19 species.....</td> <td>points = 1</td> <td><input checked="" type="checkbox"/></td> </tr> <tr> <td>< 5 species</td> <td>points = 0</td> <td><input type="checkbox"/></td> </tr> </table> <p>List species below if you want to: _____</p>	> 19 species	points = 2	<input type="checkbox"/>	5 – 19 species.....	points = 1	<input checked="" type="checkbox"/>	< 5 species	points = 0	<input type="checkbox"/>	<p style="text-align: right;">1</p>			
> 19 species	points = 2	<input type="checkbox"/>												
5 – 19 species.....	points = 1	<input checked="" type="checkbox"/>												
< 5 species	points = 0	<input type="checkbox"/>												
H 1.4	<p><u>Interspersion of Habitats</u> (see p. 76): Decided from the diagrams below whether interspersion between Cowardin vegetation (described in H1.1), or the classes and unvegetated areas (can include open water or mudflats) is high, medium, low, or none.</p> <div style="text-align: center;"> <p>None = 0 points Low = 1 point Moderate = 2 points</p> <p>High = 3 points [riparian braided channels]</p> </div> <p>Note: If you have 4 or more classes or 3 vegetation classes and open water, the rating is always “high”.</p> <p style="text-align: right;">Use map of Cowardin classes.</p>	<p>Figure <input type="checkbox"/></p> <p style="text-align: right;">3</p>												
H 1.5	<p><u>Special Habitat Features</u> (see p. 77): Check the habitat features that are present in the wetland. The number of checks is the number of points you put into the next column.</p> <p><input checked="" type="checkbox"/> Large, downed, woody debris within the wetland (> 4 in. diameter and 6 ft. long) <input checked="" type="checkbox"/> Standing snags (diameter at the bottom > 4 inches) in the wetland <input type="checkbox"/> Undercut banks are present for at least 6.6 ft. (2m) and/or overhanging vegetation extends at least 3.3 ft. (1m) over a stream (or ditch) in, or contiguous with the unit, for at least 33 ft. (10m) <input type="checkbox"/> Stable steep banks of fine material that might be used by beaver or muskrat for denning (> 30 degree slope) OR signs of recent beaver activity are present (cut shrubs or trees that have not yet turned grey/brown) <input type="checkbox"/> At least 1/4 acre of thin-stemmed persistent vegetation or woody branches are present in areas that are permanently or seasonally inundated (structures for egg-laying by amphibians) <input type="checkbox"/> Invasive plants cover less than 25% of the wetland area in each stratum of plants</p> <p>NOTE: The 20% stated in early printings of the manual on page 78 is an error.</p>	<p style="text-align: right;">2</p>												
H 1 TOTAL Score – potential for providing habitat		10												
<i>Add the points in the column above</i>														

H 2	Does the wetland have the <u>opportunity</u> to provide habitat for many species?	(only 1 score per box)
	<p>H 2.1 <u>Buffers</u> (see P. 80): Choose the description that best represents condition of buffer of wetland unit. The highest scoring criterion that applies to the wetland is to be used in the rating. See text for definition of "undisturbed".</p> <p><input type="checkbox"/> 100m (330 ft) of relatively undisturbed vegetated areas, rocky areas, or open water > 95% of circumference. No structures are within the undisturbed part of buffer (relatively undisturbed also means no grazing, no landscaping, no daily human use)..... points = 5</p> <p><input type="checkbox"/> 100m (330 ft) of relatively undisturbed vegetated areas, rocky areas, or open water > 50% circumference points = 4</p> <p><input type="checkbox"/> 50m (170 ft) of relatively undisturbed vegetated areas, rocky areas, or open water > 95% circumference points = 4</p> <p><input type="checkbox"/> 100m (330 ft) of relatively undisturbed vegetated areas, rocky areas, or open water > 25% circumference points = 3</p> <p><input type="checkbox"/> 50m (170 ft) of relatively undisturbed vegetated areas, rocky areas, or open water for > 50% circumference points = 3</p> <p>If buffer does not meet any of the criteria above:</p> <p><input type="checkbox"/> No paved areas (except paved trails) or buildings within 25m (80 ft) of wetland > 95% circumference. Light to moderate grazing or lawns are OK points = 2</p> <p><input type="checkbox"/> No paved areas of buildings within 50m of wetland for > 50% circumference. Light to moderate grazing or lawns are OK points = 2</p> <p><input type="checkbox"/> Heavy grazing in buffer points = 1</p> <p><input type="checkbox"/> Vegetated buffers are < 2m wide (6.6 ft) for more than 95% circumference (e.g. tilled fields, paving, basalt bedrock extend to edge of wetland) points = 0</p> <p><input checked="" type="checkbox"/> Buffer does not meet any of the criteria above points = 1</p> <p style="text-align: right;">Arial photo showing buffers</p>	<p>Figure <input type="checkbox"/></p> <p style="text-align: right;">1</p>
	<p>H 2.2 <u>Corridors and Connections</u> (see p. 81)</p> <p>H 2.2.1 Is the wetland part of a relatively undisturbed and unbroken vegetated corridor (either riparian or upland) that is at least 150 ft. wide, has at least a 30% cover of shrubs, forest or native undisturbed prairie, that connects to estuaries, other wetlands or undisturbed uplands that are at least 250 acres in size? (<i>Dams in riparian corridors, heavily used gravel roads, paved roads, are considered breaks in the corridor.</i>)</p> <p style="padding-left: 40px;"><input type="checkbox"/> YES = 4 points (go to H 2.3) <input checked="" type="checkbox"/> NO = go to H 2.2.2</p> <p>H. 2.2.2 Is the wetland part of a relatively undisturbed and unbroken vegetated corridor (either riparian or upland) that is at least 50 ft. wide, has at least 30% cover of shrubs or forest, and connects to estuaries, other wetlands or undisturbed uplands that are at least 25 acres in size? OR a Lake-fringe wetland, if it does not have an undisturbed corridor as in the question above?</p> <p style="padding-left: 40px;"><input type="checkbox"/> YES = 2 points (go to H 2.3) <input checked="" type="checkbox"/> NO = go to H 2.2.3</p> <p>H. 2.2.3 Is the wetland:</p> <ul style="list-style-type: none"> • Within 5 mi (8km) of a brackish or salt water estuary OR • Within 3 miles of a large field or pasture (> 40 acres) OR • Within 1 mile of a lake greater than 20 acres? <p style="padding-left: 100px;"><input checked="" type="checkbox"/> YES = 1 point <input type="checkbox"/> NO = 0 points</p>	<p style="text-align: right;">1</p>

Comments: _____

	<p>H 2.3 <u>Near or adjacent to other priority habitats listed by WDFW</u> (see p. 82): <i>(see new and complete descriptions of WDFW priority habitats, and the counties in which they can be found, in the PHS report http://wdfw.wa.gov/hab/phslist.htm)</i> Which of the following priority habitats are within 330 ft. (100m) of the wetland unit? NOTE: <i>the connections do not have to be relatively undisturbed.</i></p> <p><input type="checkbox"/> Aspen Stands: Pure or mixed stands of aspen greater than 0.4 ha (1 acre).</p> <p><input type="checkbox"/> Biodiversity Areas and Corridors: Areas of habitat that are relatively important to various species of native fish and wildlife <i>(full descriptions in WDFW PHS report p. 152).</i></p> <p><input type="checkbox"/> Herbaceous Balds: Variable size patches of grass and forbs on shallow soils over bedrock.</p> <p><input type="checkbox"/> Old-growth/Mature forests: (Old-growth west of Cascade crest) Stands of at least 2 tree species, forming a multi-layered canopy with occasional small openings; with at least 20 trees/ha (8 trees/acre) > 81 cm (32 in) dbh or > 200 years of age. (Mature forests) Stands with average diameters exceeding 53 cm (21 in) dbh; crown cover may be less than 100%; decay, decadence, numbers of snags, and quantity of large downed material is generally less than that found in old-growth; 80 - 200 years old west of the Cascade crest.</p> <p><input type="checkbox"/> Oregon white Oak: Woodlands Stands of pure oak or oak/conifer associations where canopy coverage of the oak component is important <i>(full descriptions in WDFW PHS report p. 158).</i></p> <p><input checked="" type="checkbox"/> Riparian: The area adjacent to aquatic systems with flowing water that contains elements of both aquatic and terrestrial ecosystems which mutually influence each other.</p> <p><input type="checkbox"/> Westside Prairies: Herbaceous, non-forested plant communities that can either take the form of a dry prairie or a wet prairie <i>(full descriptions in WDFW PHS report p. 161).</i></p> <p><input checked="" type="checkbox"/> Instream: The combination of physical, biological, and chemical processes and conditions that interact to provide functional life history requirements for instream fish and wildlife resources.</p> <p><input type="checkbox"/> Nearshore: Relatively undisturbed nearshore habitats. These include Coastal Nearshore, Open Coast Nearshore, and Puget Sound Nearshore. <i>(full descriptions of habitats and the definition of relatively undisturbed are in WDFW report: pp. 167-169 and glossary in Appendix A).</i></p> <p><input type="checkbox"/> Caves: A naturally occurring cavity, recess, void, or system of interconnected passages under the earth in soils, rock, ice, or other geological formations and is large enough to contain a human.</p> <p><input type="checkbox"/> Cliffs: Greater than 7.6 m (25 ft) high and occurring below 5000 ft.</p> <p><input type="checkbox"/> Talus: Homogenous areas of rock rubble ranging in average size 0.15 - 2.0 m (0.5 - 6.5 ft), composed of basalt, andesite, and/or sedimentary rock, including riprap slides and mine tailings. May be associated with cliffs.</p> <p><input type="checkbox"/> Snags and Logs: Trees are considered snags if they are dead or dying and exhibit sufficient decay characteristics to enable cavity excavation/use by wildlife. Priority snags have a diameter at breast height of > 51 cm (20 in) in western Washington and are > 2 m (6.5 ft) in height. Priority logs are > 30 cm (12 in) in diameter at the largest end, and > 6 m (20 ft) long.</p> <p style="text-align: right;">If wetland has 3 or more priority habitats = 4 points If wetland has 2 priority habitats = 3 points If wetland has 1 priority habitat = 1 point No habitats = 0 points</p> <p>Note: All vegetated wetlands are by definition a priority habitat but are not included in this list. Nearby wetlands are addressed in question H 2.4)</p>	3
	<p>H 2.4 <u>Wetland Landscape:</u> <i>Choose the one description of the landscape around the wetland that best fits (see p. 84)</i></p> <ul style="list-style-type: none"> • There are at least 3 other wetlands within 1/2 mile, and the connections between them are relatively undisturbed (light grazing between wetlands OK, as is lake shore with some boating, but connections should NOT be bisected by paved roads, fill, fields, or other development.... points = 5 <input type="checkbox"/> • The wetland is Lake-fringe on a lake with little disturbance and there are 3 other lake-fringe wetlands within 1/2 mile points = 5 <input type="checkbox"/> • There are at least 3 other wetlands within 1/2 mile, BUT the connections between them are disturbed. points = 3 <input checked="" type="checkbox"/> • The wetland fringe on a lake with disturbance and there are 3 other lake-fringe wetlands within 1/2 mile points = 3 <input type="checkbox"/> • There is at least 1 wetland within 1/2 mile points = 2 <input type="checkbox"/> • There are no wetlands within 1/2 mile..... points = 0 <input type="checkbox"/> 	3
	<p>H 2 TOTAL Score – opportunity for providing habitat <i>Add the scores from H2.1, H2.2, H2.3, H2.4</i></p>	8
	<p style="text-align: right;"><i>TOTAL for H 1 from page 8</i></p>	10
◆	<p>Total Score for Habitat Functions <i>Add the points for H 1 and H 2; then record the result on p. 1</i></p>	18

Comments: _____

CATEGORIZATION BASED ON SPECIAL CHARACTERISTICS

Please determine if the wetland meets the attributes described below and circle the appropriate answers and Category.

Wetland Type – Check off any criteria that apply to the wetland. Circle the Category when the appropriate criteria are met.	
SC1	<p>Estuarine wetlands? (see p.86)</p> <p>Does the wetland unit meet the following criteria for Estuarine wetlands?</p> <p><input type="checkbox"/> The dominant water regime is tidal, <input type="checkbox"/> Vegetated, and <input type="checkbox"/> With a salinity greater than 0.5 ppt.</p> <p style="text-align: center;"><input type="checkbox"/> YES = Go to SC 1.1 <input checked="" type="checkbox"/> NO</p>
	<p>SC 1.1 Is the wetland unit within a National Wildlife Refuge, National Park, National Estuary Reserve, Natural Area Preserve, State Park or Educational, Environmental, or Scientific Reserve designated under WAC 332-30-151? <input type="checkbox"/> YES = Category I <input type="checkbox"/> NO = go to SC 1.2</p>
	<p>SC 1.2 Is the wetland at least 1 acre in size and meets at least two of the following conditions?</p> <p style="text-align: center;"><input type="checkbox"/> YES = Category I <input type="checkbox"/> NO = Category II</p> <p><input type="checkbox"/> The wetland is relatively undisturbed (has no diking, ditching, filling, cultivation, grazing, and has less than 10% cover of non-native plant species. If the non-native <i>Spartina</i> spp. are only species that cover more than 10% of the wetland, then the wetland should be given a dual rating (I/II). The area of <i>Spartina</i> would be rated a Category II while the relatively undisturbed upper marsh with native species would be a Category I. Do not, however, exclude the area of <i>Spartina</i> in determining the size threshold of 1 acre.</p> <p><input type="checkbox"/> At least 3/4 of the landward edge of the wetland has a 100 ft. buffer of shrub, forest, or un-grazed or un-mowed grassland</p> <p><input type="checkbox"/> The wetland has at least 2 of the following features: tidal channels, depressions with open water, or contiguous freshwater wetlands.</p>
SC2	<p>Natural Heritage Wetlands (see p. 87)</p> <p>Natural Heritage wetlands have been identified by the Washington Natural Heritage Program/DNR as either high quality undisturbed wetlands or wetlands that support state Threatened, Endangered, or Sensitive plant species.</p> <p>SC 2.1 Is the wetland being rated in a Section/Township/Range that contains a natural heritage wetland? (This question is used to screen out most sites before you need to contact WNHP/DNR.)</p> <p style="text-align: center;"><input type="checkbox"/> S/T/R information from Appendix D <input type="checkbox"/> or accessed from WNHP/DNR web site <input type="checkbox"/> YES Contact WNHP/DNR (see p. 79) and go to SC 2.2 <input checked="" type="checkbox"/> NO</p> <p>SC 2.2 Has DNR identified the wetland as a high quality undisturbed wetland or as a site with state threatened or endangered plant species?</p> <p style="text-align: center;"><input type="checkbox"/> YES = Category 1 <input checked="" type="checkbox"/> NO not a Heritage Wetland</p>
SC3	<p>Bogs (see p. 87)</p> <p>Does the wetland (or any part of the unit) meet both the criteria for soils and vegetation in bogs? Use the key below to identify if the wetland is a bog. If you answer yes you will still need to rate the wetland based on its function.</p> <ol style="list-style-type: none"> Does the unit have organic soil horizons (i.e. layers of organic soil), either peats or mucks, that compose 16 inches or more of the first 32 inches of soil profile? (See Appendix B for a field key to identify organic soils)? <input type="checkbox"/> YES = go to question 3 <input checked="" type="checkbox"/> NO = go to question 2 Does the wetland have organic soils, either peats or mucks that are less than 16 inches deep over bedrock, or an impermeable hardpan such as clay or volcanic ash, or that are floating on a lake or pond? <input type="checkbox"/> YES = go to question 3 <input checked="" type="checkbox"/> NO = is not a bog for purpose of rating Does the unit have more than 70% cover of mosses at ground level, AND other plants, if present, consist of the “bog” species listed in Table 3 as a significant component of the vegetation (more than 30% of the total shrub and herbaceous cover consists of species in Table 3)? <input type="checkbox"/> YES = Is a bog for purpose of rating <input checked="" type="checkbox"/> NO = go to question 4 <p>NOTE: If you are uncertain about the extent of mosses in the understory you may substitute that criterion by measuring the pH of the water that seeps into a hole dug at least 16” deep. If the pH is less than 5.0 and the “bog” plant species in Table 3 are present, the wetland is a bog.</p> <ol style="list-style-type: none"> Is the unit forested (> 30% cover) with sitka spruce, subalpine fir, western red cedar, western hemlock, lodgepole pine, quaking aspen, Englemann’s spruce, or western white pine. WITH any of the species (or combination of species) on the bog species plant list in Table 3 as a significant component of the ground cover (> 30% coverage of the total shrub/herbaceous cover)? <input type="checkbox"/> YES = Category I <input checked="" type="checkbox"/> NO = Is not a bog for purpose of rating

SC4	<p>Forested Wetlands (see p. 90)</p> <p>Does the wetland have at least 1 acre of forest that meet one of these criteria for the Department of Fish and Wildlife’s forests as priority habitats? <i>If you answer yes you will still need to rate the wetland based on its function.</i></p> <p><input type="checkbox"/> Old-growth forests: (west of Cascade Crest) Stands of at least two three species forming a multi-layered canopy with occasional small openings; with at least 8 trees/acre (20 trees/hectare) that are at least 200 years of age OR have a diameter at breast height (dbh) of 32 inches (81 cm or more). NOTE: The criterion for dbh is based on measurements for upland forests. Two-hundred year old trees in wetlands will often have a smaller dbh because their growth rates are often slower. The DFW criterion is and “OR” so old-growth forests do not necessarily have to have trees of this diameter.</p> <p><input type="checkbox"/> Mature forests: (west of the Cascade Crest) Stands where the largest trees are 80 – 200 years old OR have an average diameters (dbh) exceeding 21 inches (53 cm); crown cover may be less than 100%; decay, decadence, numbers of snags, and quantity of large downed material is generally less than that found in old-growth.</p> <p><input type="checkbox"/> YES = Category I <input checked="" type="checkbox"/> NO = not a forested wetland with special characteristics</p>	<p>Cat. I <input type="checkbox"/></p>
SC5	<p>Wetlands in Coastal Lagoons (see p. 91)</p> <p>Does the wetland meet all of the following criteria of a wetland in a coastal lagoon?</p> <p><input type="checkbox"/> The wetland lies in a depression adjacent to marine waters that is wholly or partially separated from marine waters by sandbanks, gravel banks, shingle, or, less frequently, rocks.</p> <p><input type="checkbox"/> The lagoon in which the wetland is located contains surface water that is saline or brackish (> 0.5 ppt) during most of the year in at least a portion of the lagoon (<i>needs to be measured near the bottom.</i>)</p> <p><input type="checkbox"/> YES = Go to SC 5.1 <input checked="" type="checkbox"/> NO not a wetland in a coastal lagoon</p> <p>SC 5.1 Does the wetland meet all of the following three conditions?</p> <p><input type="checkbox"/> The wetland is relatively undisturbed (has no diking, ditching, filling, cultivation, grazing) and has less than 20% cover of invasive plant species (see list of invasive species on p. 74).</p> <p><input type="checkbox"/> At least 3/4 of the landward edge of the wetland has a 100 ft. buffer of shrub, forest, or un-grazed or un-mowed grassland.</p> <p><input type="checkbox"/> The wetland is larger than 1/10 acre (4350 square ft.)</p> <p><input type="checkbox"/> YES = Category I <input type="checkbox"/> NO = Category II</p>	<p>Cat. I <input type="checkbox"/></p> <p>Cat. II <input type="checkbox"/></p>
SC6	<p>Interdunal Wetlands (see p. 93)</p> <p>Is the wetland west of the 1889 line (also called the Western Boundary of Upland Ownership or WBUO)?</p> <p><input type="checkbox"/> YES = Go to SC 6.1 <input checked="" type="checkbox"/> NO not an interdunal wetland for rating</p> <p><i>If you answer yes you will still need to rate the wetland based on its functions.</i></p> <p>In practical terms that means the following geographic areas:</p> <ul style="list-style-type: none"> • Long Beach Peninsula -- lands west of SR 103 • Grayland-Westport -- lands west of SR 105 • Ocean Shores-Copalis – lands west of SR 115 and SR 109 <p>SC 6.1 Is the wetland one acre or larger, or is it in a mosaic of wetlands that is one acre or larger?</p> <p><input type="checkbox"/> YES = Category II <input type="checkbox"/> NO = go to SC 6.2</p> <p>SC 6.2 Is the wetland between 0.1 and 1 acre, or is it in a mosaic of wetlands that is between 0.1 and 1 acre?</p> <p><input type="checkbox"/> YES = Category III</p>	<p>Cat. II <input type="checkbox"/></p> <p>Cat. III <input type="checkbox"/></p>
◆	<p>Category of wetland based on Special Characteristics</p> <p>Choose the “highest” rating if wetland falls into several categories, and record on p. 1. If you answered NO for all types enter “Not Applicable” on p. 1</p>	<p>NA</p>

Comments:

WETLAND RATING FORM – WESTERN WASHINGTON
 Version 2 – Updated July 2006 to increase accuracy and reproducibility among users
 Updated Oct. 2008 with the new WDFW definitions for priority habitats

Name of wetland (if known): BNSF East

Date of site visit: February 14, 2013

Rated by: C. Douglas & J. Pursley Trained by Ecology? Yes No

Date of training: May 2007

SEC: 29 TOWNSHP: 24N RNGE: 5E

Is S/T/R in Appendix D? Yes No

Map of wetland unit: Figure _____ Estimated size _____

SUMMARY OF RATING

Category based on FUNCTIONS provided by wetland: I II III IV

Category I =	Score > 70
Category II =	Score 51 - 69
Category III =	Score 30 – 50
Category IV =	Score < 30

Score for Water Quality Functions	14
Score for Hydrologic Functions	16
Score for Habitat Functions	7
TOTAL Score for Functions	37

Category based on SPECIAL CHARACTERISTICS of Wetland I II Does not apply

Final Category (choose the “highest” category from above”)

III

Summary of basic information about the wetland unit.

Wetland Unit has Special Characteristics		Wetland HGM Class used for Rating	
Estuarine	<input type="checkbox"/>	Depressional	<input checked="" type="checkbox"/>
Natural Heritage Wetland	<input type="checkbox"/>	Riverine	<input type="checkbox"/>
Bog	<input type="checkbox"/>	Lake-fringe	<input type="checkbox"/>
Mature Forest	<input type="checkbox"/>	Slope	<input type="checkbox"/>
Old Growth Forest	<input type="checkbox"/>	Flats	<input type="checkbox"/>
Coastal Lagoon	<input type="checkbox"/>	Freshwater Tidal	<input type="checkbox"/>
Interdunal	<input type="checkbox"/>		<input type="checkbox"/>
None of the above	<input checked="" type="checkbox"/>	Check if unit has multiple HGM classes present	<input type="checkbox"/>

Does the wetland being rated meet any of the criteria below? If you answer YES to any of the questions below you will need to protect the wetland according to the regulations regarding the special characteristics found in the wetland.

Check List for Wetlands that Need Additional Protection (in addition to the protection recommended for its category)	YES	NO
SP1. <i>Has the wetland unit been documented as a habitat for any Federally listed Threatened or Endangered animal or plant species (T/E species)?</i> For the purposes of this rating system, “documented” means the wetland is on the appropriate state or federal database.	<input type="checkbox"/>	<input checked="" type="checkbox"/>
SP2. <i>Has the wetland unit been documented as habitat for any State listed Threatened or Endangered animal species?</i> For the purposes of this rating system, “documented” means the wetland is on the appropriate state database. Note: Wetlands with State listed plant species are categorized as Category 1 Natural Heritage Wetlands (see p. 19 of data form).	<input type="checkbox"/>	<input checked="" type="checkbox"/>
SP3. <i>Does the wetland unit contain individuals of Priority species listed by the WDFW for the state?</i>	<input type="checkbox"/>	<input checked="" type="checkbox"/>
SP4. <i>Does the wetland unit have a local significance in addition to its functions?</i> For example, the wetland has been identified in the Shoreline Master Program, the Critical Areas Ordinance, or in a local management plan as having special significance.	<input type="checkbox"/>	<input checked="" type="checkbox"/>

To complete the next part of the data sheet you will need to determine the Hydrogeomorphic Class of the wetland being rated.

The hydrogeomorphic classification groups wetlands in to those that function in similar ways. This simplifies the questions needed to answer how well the wetland functions. The Hydrogeomorphic Class of a wetland can be determined using the key below. See p. 24 for more detailed instructions on classifying wetlands.

Classification of Vegetated Wetlands for Western Washington

If the hydrologic criteria listed in each question do not apply to the entire unit being rated, you probably have a unit with multiple HGM classes. In this case, identify which hydrologic criteria in questions 1-7 apply, and go to Question 8.

1. Are the water levels in the entire unit usually controlled by tides (i.e. except during floods)?
 NO – go to 2 YES – the wetland class is **Tidal Fringe**
 If yes, is the salinity of the water during periods of annual low flow below 0.5 ppt (parts per thousand)?
 YES – **Freshwater Tidal Fringe** NO – **Saltwater Tidal Fringe (Estuarine)**
*If your wetland can be classified as a Freshwater Tidal Fringe use the forms for **Riverine** wetlands. If it is a Saltwater Tidal Fringe it is rated as an **Estuarine** wetland. Wetlands that were call estuarine in the first and second editions of the rating system are called Salt Water Tidal Fringe in the Hydrogeomorphic Classification. Estuarine wetlands were categorized separately in the earlier editions, and this separation is being kept in this revision. To maintain consistency between editions, the term “Estuarine” wetland is kept. Please note, however, that the characteristics that define Category I and II estuarine wetlands have changed (see p. _____).*
-
2. The entire wetland unit is flat and precipitation is only source (>90%) of water to it. Groundwater and surface water runoff are NOT sources of water to the unit.
 NO – go to 3 YES – The wetland class is **Flats**
 If your wetland can be classified as a “Flats” wetland, use the form for **Depressional** wetlands.
-
3. Does the entire wetland meet both of the following criteria?
 The vegetated part of the wetland is on the shores of a body of permanent open water (without any vegetation on the surface) where at least 20 acres (8ha) in size;
 At least 30% of the open water area is deeper than 6.6 (2 m)?
 NO – go to 4 YES – The wetland class is **Lake-fringe (Lacustrine Fringe)**
-
4. Does the entire wetland meet all of the following criteria?
 The wetland is on a slope (*slope can be very gradual*).
 The water flows through the wetland in one direction (unidirectional) and usually comes from seeps. It may flow subsurface, as sheetflow, or in a swale without distinct banks.
 The water leaves the wetland **without being impounded**?
 NOTE: *Surface water does not pond in these types of wetlands except occasionally in very small and shallow depressions or behind hummocks (depressions are usually <3 ft diameter and less than 1 foot deep).*
 NO – go to 5 YES – The wetland class is **Slope**
-
5. Does the entire wetland meet all of the following criteria?
 The unit is in a valley or stream channel where it gets inundated by overbank flooding from that stream or river.
 The overbank flooding occurs at least once every two years.
 NOTE: *The riverine unit can contain depressions that are filled with water when the river is not flooding..*
 NO – go to 6 YES – The wetland class is **Riverine**
-
6. Is the entire wetland unit in a topographic depression in which water ponds, or is saturated to the surface, at some time of the year. This means that any outlet, if present is higher than the interior of the wetland.
 NO – go to 7 YES – The wetland class is **Depressional**
-
7. Is the entire wetland located in a very flat area with no obvious depression and no overbank flooding. The unit does not pond surface water more than a few inches. The unit seems to be maintained by high groundwater in the area. The wetland may be ditched, but has no obvious natural outlet.
 No – go to 8 YES – The wetland class is **Depressional**
-
8. Your wetland unit seems to be difficult to classify and probably contains several different HGM classes. For example, seeps at the base of a slope may grade into a riverine floodplain, or a small stream within a depressional wetland has a zone of flooding along its sides. GO BACK AND IDENTIFY WHICH OF THE HYDROLOGIC REGIMES DESCRIBED IN QUESTIONS 1-7 APPLY TO DIFFERENT AREAS IN THE UNIT (make a rough sketch to help you decide). Use the following table to identify the appropriate class to use for the rating system if you have several HGM classes present within your wetland. NOTE: Use this table only if the class that is recommended in the second column represents 10% or more of the total area of the wetland unit being rated. If the area of the class listed in column 2 is less than 10% of the unit, classify the wetland using the class that represents more than 90% of the total area.

HGM Classes within the wetland unit being rated	HGM Class to Use in Rating
Slope + Riverine	Riverine
Slope + Depressional	Depressional
Slope + Lake-fringe	Lake-fringe
Depressional + Riverine along stream within boundary	Depressional
Depressional + Lake-fringe	Depressional
Salt Water Tidal Fringe and any other class of freshwater wetland	Treat as ESTUARINE under wetlands with special characteristics

If you are unable still to determine which of the above criteria apply to your wetland, or you have more than 2 HGM classes within a wetland boundary, classify the wetland as **Depressional** for the rating.

D Depressional and Flat Wetlands		Points
WATER QUALITY FUNCTIONS – Indicators that wetland functions to improve water quality.		(only 1 score per box) (see p.38)
D 1	Does the wetland have the <u>potential</u> to improve water quality?	
D 1.1	Characteristics of surface water flows out of the wetland: • Unit is a depression with no surface water leaving it (no outlet) points = 3 <input type="checkbox"/> • Unit has an intermittently flowing, OR highly constricted, permanently flowing outlet ... points = 2 <input checked="" type="checkbox"/> • Unit has an unconstricted, or slightly constricted, surface outlet (<i>permanently flowing</i>) .. points = 1 <input type="checkbox"/> • Unit is a “flat” depression (Q.7 on key), or in the Flats class, with permanent surface outflow and no obvious natural outlet and/or outlet is a man-made ditch..... points = 1 <input type="checkbox"/> <i>(If ditch is not permanently flowing treat unit as “intermittently flowing”)</i> Provide photo or drawing	Figure <input type="checkbox"/> 2
D 1.2	The soil 2 inches below the surface (or duff layer) is clay or organic (<i>use NRCS definitions</i>) YES points = 4 NO points = 0	0
D 1.3	Characteristics of persistent vegetation (emergent, shrub, and/or forest Cowardin class): • Wetland has persistent, ungrazed vegetation > = 95% of area points = 5 <input type="checkbox"/> • Wetland has persistent, ungrazed vegetation > = 1/2 of area points = 3 <input type="checkbox"/> • Wetland has persistent, ungrazed vegetation > = 1/10 of area points = 1 <input checked="" type="checkbox"/> • Wetland has persistent, ungrazed vegetation < 1/10 of area points = 0 <input type="checkbox"/> Map of Cowardin vegetation classes	Figure <input type="checkbox"/> 1
D 1.4	Characteristics of seasonal ponding or inundation: <i>This is the area of the wetland that is ponded for at least 2 months, but dries out sometime during the year. Do not count the area that is permanently ponded. Estimate area as the average condition 5 out of 10 years.</i> • Area seasonally ponded is > 1/2 total area of wetland points = 4 <input checked="" type="checkbox"/> • Area seasonally ponded is > 1/4 total area of wetland points = 2 <input type="checkbox"/> • Area seasonally ponded is < 1/4 total area of wetland points = 0 <input type="checkbox"/> Map of Hydroperiods	Figure <input type="checkbox"/> 4
Total for D 1		<i>Add the points in the boxes above</i> 7
D 2	Does the wetland have the <u>opportunity</u> to improve water quality?	(see p. 44)
Answer YES if you know or believe there are pollutants in groundwater or surface water coming into the wetland that would otherwise reduce water quality in streams, lakes or groundwater downgradient from the wetland? <i>Note which of the following conditions provide the sources of pollutants. A unit may have pollutants coming from several sources, but any single source would qualify as opportunity.</i> <input type="checkbox"/> Grazing in the wetland or within 150 ft <input checked="" type="checkbox"/> Untreated stormwater discharges to wetland <input type="checkbox"/> Tilled fields or orchards within 150 ft. of wetland <input checked="" type="checkbox"/> A stream or culvert discharges into wetland that drains developed areas, residential areas, farmed fields, roads, or clear-cut logging <input checked="" type="checkbox"/> Residential, urban areas, golf courses are within 150 ft. of wetland <input type="checkbox"/> Wetland is fed by groundwater high in phosphorus or nitrogen <input type="checkbox"/> Other _____		Multiplier 2
<input checked="" type="checkbox"/> YES multiplier is 2 <input type="checkbox"/> NO multiplier is 1		
◆ TOTAL – Water Quality Functions		Multiply the score from D1 by D2; then add score to table on p. 1 14
HYDROLOGIC FUNCTIONS – Indicators that wetland unit functions to reduce flooding and stream degradation.		
D 3	Does the wetland have the <u>potential</u> to reduce flooding and erosion?	(see p.46)
D 3.1	Characteristics of surface water flows out of the wetland unit • Unit is a depression with no surface water leaving it (no outlet) points = 4 <input type="checkbox"/> • Unit has an intermittently flowing, OR highly constricted permanently flowing outlet points = 2 <input checked="" type="checkbox"/> • Unit is a “flat” depression (Q.7 on key) or in the Flats class, with permanent surface outflow and no obvious natural outlet and/or outlet is a man-made ditch..... points = 1 <input type="checkbox"/> <i>(If ditch is not permanently flowing treat unit as “intermittently flowing”)</i> • Unit has an unconstricted, or slightly constricted, surface outlet (<i>permanently flowing</i>) points = 0	2
D 3.2	Depth of storage during wet periods. <i>Estimate the height of ponding above the bottom of the outlet. For units with no outlet measure from the surface of permanent water or deepest part (if dry).</i> • Marks of ponding are 3 ft. or more above the surface or bottom of the outlet points = 7 <input type="checkbox"/> • The wetland is a “headwater” wetland..... points = 5 <input type="checkbox"/> • Marks of ponding between 2 ft. to < 3 ft. from surface or bottom of outlet points = 5 <input type="checkbox"/> • Marks are at least 0.5 ft. to < 2 ft. from surface or bottom of outlet points = 3 <input checked="" type="checkbox"/> • Wetland is flat (yes to Q.2 or Q.7 on key) but has small depressions on the surface that trap water . points = 1 <input type="checkbox"/> • Marks of ponding less than 0.5 ft points = 0 <input type="checkbox"/>	3
D 3.3	Contribution of wetland unit to storage in the watershed: <i>Estimate the ratio of the area of upstream basin contributing surface water to the wetland to the area of the wetland unit itself.</i> • The area of the basin is less than 10 times the area of unit..... points = 5 <input type="checkbox"/> • The area of the basin is 10 to 100 times the area of the unit..... points = 3 <input checked="" type="checkbox"/> • The area of the basin is more than 100 times the area of the unit points = 0 <input type="checkbox"/> • Entire unit is in the FLATS class points = 5 <input type="checkbox"/>	3
Total for D 3		<i>Add the points in the boxes above</i> 8

D 4	<p>Does the wetland have the <u>opportunity</u> to reduce flooding and erosion?</p> <p>Answer YES if the unit is in a location in the watershed where the flood storage, or reduction in water velocity, it provides helps protect downstream property and aquatic resources from flooding or excessive and/or erosive flows. Answer NO if the water coming into the wetland is controlled by a structure such as flood gate, tide gate, flap valve, reservoir etc. OR you estimate that more than 90% of the water in the wetland is from groundwater in areas where damaging groundwater flooding does not occur. <i>Note which of the following indicators of opportunity apply.</i></p> <p><input type="checkbox"/> Wetland is in a headwater of a river or stream that has flooding problems.</p> <p><input checked="" type="checkbox"/> Wetland drains to a river or stream that has flooding problems</p> <p><input type="checkbox"/> Wetland has no outlet and impounds surface runoff water that might otherwise flow into a river or stream that has flooding problems</p> <p><input type="checkbox"/> Other _____</p> <p><input checked="" type="checkbox"/> YES multiplier is 2 <input type="checkbox"/> NO multiplier is 1</p>	<p>(see p. 49)</p> <p>Multiplier</p> <p>2</p>
◆	<p>TOTAL – Hydrologic Functions Multiply the score from D3 by D4; then <i>add score to table on p. 1</i></p>	<p><u>16</u></p>

Comments: _____

<i>These questions apply to wetlands of all HGM classes.</i>		Points								
HABITAT FUNCTIONS – Indicators that wetland functions to provide important habitat.		(only 1 score per box)								
H 1	Does the wetland have the <u>potential</u> to provide habitat for many species?									
H 1.1	<p>Vegetation structure (see P. 72): Check the types of vegetation classes present (as defined by Cowardin) – Size threshold for each class is 1/4 acre or more than 10% of the area if unit is smaller than 2.5 acres.</p> <p><input type="checkbox"/> Aquatic Bed <input checked="" type="checkbox"/> Emergent plants <input type="checkbox"/> Scrub/shrub (areas where shrubs have > 30% cover) <input type="checkbox"/> Forested (areas where trees have > 30% cover)</p> <p>If the unit has a forested class check if: <input type="checkbox"/> The forested class has 3 out of 5 strata (canopy, sub-canopy, shrubs, herbaceous, moss/ground-cover) that each cover 20% within the forested polygon.</p> <p>Add the number of vegetation types that qualify. If you have:</p> <table style="width: 100%;"> <tr> <td style="width: 50%;">4 structures or more..... points = 4 <input type="checkbox"/></td> <td style="width: 50%; text-align: right;">Map of Cowardin vegetation classes</td> </tr> <tr> <td>2 structures..... points = 1 <input type="checkbox"/></td> <td style="text-align: right;">3 structures..... points = 2 <input type="checkbox"/></td> </tr> <tr> <td></td> <td style="text-align: right;">1 structure..... points = 0 <input checked="" type="checkbox"/></td> </tr> </table>	4 structures or more..... points = 4 <input type="checkbox"/>	Map of Cowardin vegetation classes	2 structures..... points = 1 <input type="checkbox"/>	3 structures..... points = 2 <input type="checkbox"/>		1 structure..... points = 0 <input checked="" type="checkbox"/>	<p>Figure <input type="checkbox"/></p> <p style="text-align: center;">0</p>		
4 structures or more..... points = 4 <input type="checkbox"/>	Map of Cowardin vegetation classes									
2 structures..... points = 1 <input type="checkbox"/>	3 structures..... points = 2 <input type="checkbox"/>									
	1 structure..... points = 0 <input checked="" type="checkbox"/>									
H 1.2	<p>Hydroperiods (see p.73): Check the types of water regimes (hydroperiods) present within the wetland. The water regime has to cover more than 10% of the wetland or 1/4 acre to count (see text for descriptions of hydroperiods).</p> <p><input type="checkbox"/> Permanently flooded or inundated <input checked="" type="checkbox"/> Seasonally flooded or inundated <input checked="" type="checkbox"/> Occasionally flooded or inundated <input checked="" type="checkbox"/> Saturated only <input type="checkbox"/> Permanently flowing stream or river in, or adjacent to, the wetland <input type="checkbox"/> Seasonally flowing stream in, or adjacent to, the wetland</p> <p><input type="checkbox"/> Lake-fringe wetland..... = 2 points <input type="checkbox"/> Freshwater tidal wetland..... = 2 points</p> <table style="width: 100%;"> <tr> <td style="width: 50%;">4 or more types present</td> <td style="width: 50%; text-align: right;">points = 3 <input type="checkbox"/></td> </tr> <tr> <td>3 or more types present</td> <td style="text-align: right;">points = 2 <input type="checkbox"/></td> </tr> <tr> <td>2 types present</td> <td style="text-align: right;">points = 1 <input checked="" type="checkbox"/></td> </tr> <tr> <td>1 type present</td> <td style="text-align: right;">points = 0 <input type="checkbox"/></td> </tr> </table> <p style="text-align: right;">Map of hydroperiods</p>	4 or more types present	points = 3 <input type="checkbox"/>	3 or more types present	points = 2 <input type="checkbox"/>	2 types present	points = 1 <input checked="" type="checkbox"/>	1 type present	points = 0 <input type="checkbox"/>	<p>Figure <input type="checkbox"/></p> <p style="text-align: center;">1</p>
4 or more types present	points = 3 <input type="checkbox"/>									
3 or more types present	points = 2 <input type="checkbox"/>									
2 types present	points = 1 <input checked="" type="checkbox"/>									
1 type present	points = 0 <input type="checkbox"/>									
H 1.3	<p>Richness of Plant Species (see p. 75): Count the number of plant species in the wetland that cover at least 10 ft² (different patches of the same species can be combined to meet the size threshold) You do not have to name the species. Do not include Eurasian Milfoil, reed canarygrass, purple loosestrife, Canadian Thistle.</p> <p>If you counted:</p> <table style="width: 100%;"> <tr> <td style="width: 50%;">> 19 species</td> <td style="width: 50%; text-align: right;">points = 2 <input type="checkbox"/></td> </tr> <tr> <td>5 – 19 species.....</td> <td style="text-align: right;">points = 1 <input checked="" type="checkbox"/></td> </tr> <tr> <td>< 5 species</td> <td style="text-align: right;">points = 0 <input type="checkbox"/></td> </tr> </table> <p>List species below if you want to:</p> <p>_____</p>	> 19 species	points = 2 <input type="checkbox"/>	5 – 19 species.....	points = 1 <input checked="" type="checkbox"/>	< 5 species	points = 0 <input type="checkbox"/>	<p style="text-align: center;">1</p>		
> 19 species	points = 2 <input type="checkbox"/>									
5 – 19 species.....	points = 1 <input checked="" type="checkbox"/>									
< 5 species	points = 0 <input type="checkbox"/>									
H 1.4	<p>Interspersion of Habitats (see p. 76): Decided from the diagrams below whether interspersion between Cowardin vegetation (described in H1.1), or the classes and unvegetated areas (can include open water or mudflats) is high, medium, low, or none.</p> <div style="text-align: center;"> <p>None = 0 points Low = 1 point Moderate = 2 points</p> <p>High = 3 points [riparian braided channels]</p> </div> <p>Note: If you have 4 or more classes or 3 vegetation classes and open water, the rating is always “high”.</p> <p style="text-align: right;">Use map of Cowardin classes.</p>	<p>Figure <input type="checkbox"/></p> <p style="text-align: center;">1</p>								
H 1.5	<p>Special Habitat Features (see p. 77): Check the habitat features that are present in the wetland. The number of checks is the number of points you put into the next column.</p> <p><input type="checkbox"/> Large, downed, woody debris within the wetland (> 4 in. diameter and 6 ft. long) <input type="checkbox"/> Standing snags (diameter at the bottom > 4 inches) in the wetland <input type="checkbox"/> Undercut banks are present for at least 6.6 ft. (2m) and/or overhanging vegetation extends at least 3.3 ft. (1m) over a stream (or ditch) in, or contiguous with the unit, for at least 33 ft. (10m) <input type="checkbox"/> Stable steep banks of fine material that might be used by beaver or muskrat for denning (> 30 degree slope) OR signs of recent beaver activity are present (cut shrubs or trees that have not yet turned grey/brown) <input type="checkbox"/> At least 1/4 acre of thin-stemmed persistent vegetation or woody branches are present in areas that are permanently or seasonally inundated (structures for egg-laying by amphibians) <input type="checkbox"/> Invasive plants cover less than 25% of the wetland area in each stratum of plants</p> <p>NOTE: The 20% stated in early printings of the manual on page 78 is an error.</p>	<p style="text-align: center;">0</p>								
H 1 TOTAL Score – potential for providing habitat		3								
<i>Add the points in the column above</i>										

H 2	Does the wetland have the <u>opportunity</u> to provide habitat for many species?	(only 1 score per box)
	<p>H 2.1 <u>Buffers</u> (see P. 80): Choose the description that best represents condition of buffer of wetland unit. The highest scoring criterion that applies to the wetland is to be used in the rating. See text for definition of "undisturbed".</p> <p><input type="checkbox"/> 100m (330 ft) of relatively undisturbed vegetated areas, rocky areas, or open water > 95% of circumference. No structures are within the undisturbed part of buffer (relatively undisturbed also means no grazing, no landscaping, no daily human use)..... points = 5</p> <p><input type="checkbox"/> 100m (330 ft) of relatively undisturbed vegetated areas, rocky areas, or open water > 50% circumference points = 4</p> <p><input type="checkbox"/> 50m (170 ft) of relatively undisturbed vegetated areas, rocky areas, or open water > 95% circumference points = 4</p> <p><input type="checkbox"/> 100m (330 ft) of relatively undisturbed vegetated areas, rocky areas, or open water > 25% circumference points = 3</p> <p><input type="checkbox"/> 50m (170 ft) of relatively undisturbed vegetated areas, rocky areas, or open water for > 50% circumference points = 3</p> <p>If buffer does not meet any of the criteria above:</p> <p><input type="checkbox"/> No paved areas (except paved trails) or buildings within 25m (80 ft) of wetland > 95% circumference. Light to moderate grazing or lawns are OK points = 2</p> <p><input type="checkbox"/> No paved areas of buildings within 50m of wetland for > 50% circumference. Light to moderate grazing or lawns are OK points = 2</p> <p><input type="checkbox"/> Heavy grazing in buffer points = 1</p> <p><input type="checkbox"/> Vegetated buffers are < 2m wide (6.6 ft) for more than 95% circumference (e.g. tilled fields, paving, basalt bedrock extend to edge of wetland) points = 0</p> <p><input checked="" type="checkbox"/> Buffer does not meet any of the criteria above points = 1</p> <p style="text-align: right;">Arial photo showing buffers</p>	<p>Figure <input type="checkbox"/></p> <p style="text-align: right;">1</p>
	<p>H 2.2 <u>Corridors and Connections</u> (see p. 81)</p> <p>H 2.2.1 Is the wetland part of a relatively undisturbed and unbroken vegetated corridor (either riparian or upland) that is at least 150 ft. wide, has at least a 30% cover of shrubs, forest or native undisturbed prairie, that connects to estuaries, other wetlands or undisturbed uplands that are at least 250 acres in size? (<i>Dams in riparian corridors, heavily used gravel roads, paved roads, are considered breaks in the corridor.</i>)</p> <p style="padding-left: 40px;"><input type="checkbox"/> YES = 4 points (go to H 2.3) <input checked="" type="checkbox"/> NO = go to H 2.2.2</p> <p>H. 2.2.2 Is the wetland part of a relatively undisturbed and unbroken vegetated corridor (either riparian or upland) that is at least 50 ft. wide, has at least 30% cover of shrubs or forest, and connects to estuaries, other wetlands or undisturbed uplands that are at least 25 acres in size? OR a Lake-fringe wetland, if it does not have an undisturbed corridor as in the question above?</p> <p style="padding-left: 40px;"><input type="checkbox"/> YES = 2 points (go to H 2.3) <input checked="" type="checkbox"/> NO = go to H 2.2.3</p> <p>H. 2.2.3 Is the wetland:</p> <ul style="list-style-type: none"> • Within 5 mi (8km) of a brackish or salt water estuary OR • Within 3 miles of a large field or pasture (> 40 acres) OR • Within 1 mile of a lake greater than 20 acres? <p style="padding-left: 100px;"><input type="checkbox"/> YES = 1 point</p> <p style="padding-left: 100px;"><input checked="" type="checkbox"/> NO = 0 points</p>	<p style="text-align: right;">0</p>

Comments: _____

	<p>H 2.3 <u>Near or adjacent to other priority habitats listed by WDFW</u> (see p. 82): (see new and complete descriptions of WDFW priority habitats, and the counties in which they can be found, in the PHS report http://wdfw.wa.gov/hab/phslist.htm) Which of the following priority habitats are within 330 ft. (100m) of the wetland unit? <i>NOTE: the connections do not have to be relatively undisturbed.</i></p> <p><input type="checkbox"/> Aspen Stands: Pure or mixed stands of aspen greater than 0.4 ha (1 acre).</p> <p><input type="checkbox"/> Biodiversity Areas and Corridors: Areas of habitat that are relatively important to various species of native fish and wildlife (full descriptions in WDFW PHS report p. 152).</p> <p><input type="checkbox"/> Herbaceous Balds: Variable size patches of grass and forbs on shallow soils over bedrock.</p> <p><input type="checkbox"/> Old-growth/Mature forests: (Old-growth west of Cascade crest) Stands of at least 2 tree species, forming a multi-layered canopy with occasional small openings; with at least 20 trees/ha (8 trees/acre) > 81 cm (32 in) dbh or > 200 years of age. (Mature forests) Stands with average diameters exceeding 53 cm (21 in) dbh; crown cover may be less than 100%; decay, decadence, numbers of snags, and quantity of large downed material is generally less than that found in old-growth; 80 - 200 years old west of the Cascade crest.</p> <p><input type="checkbox"/> Oregon white Oak: Woodlands Stands of pure oak or oak/conifer associations where canopy coverage of the oak component is important (full descriptions in WDFW PHS report p. 158).</p> <p><input type="checkbox"/> Riparian: The area adjacent to aquatic systems with flowing water that contains elements of both aquatic and terrestrial ecosystems which mutually influence each other.</p> <p><input type="checkbox"/> Westside Prairies: Herbaceous, non-forested plant communities that can either take the form of a dry prairie or a wet prairie (full descriptions in WDFW PHS report p. 161).</p> <p><input type="checkbox"/> Instream: The combination of physical, biological, and chemical processes and conditions that interact to provide functional life history requirements for instream fish and wildlife resources.</p> <p><input type="checkbox"/> Nearshore: Relatively undisturbed nearshore habitats. These include Coastal Nearshore, Open Coast Nearshore, and Puget Sound Nearshore. (full descriptions of habitats and the definition of relatively undisturbed are in WDFW report: pp. 167-169 and glossary in Appendix A).</p> <p><input type="checkbox"/> Caves: A naturally occurring cavity, recess, void, or system of interconnected passages under the earth in soils, rock, ice, or other geological formations and is large enough to contain a human.</p> <p><input type="checkbox"/> Cliffs: Greater than 7.6 m (25 ft) high and occurring below 5000 ft.</p> <p><input type="checkbox"/> Talus: Homogenous areas of rock rubble ranging in average size 0.15 - 2.0 m (0.5 - 6.5 ft), composed of basalt, andesite, and/or sedimentary rock, including riprap slides and mine tailings. May be associated with cliffs.</p> <p><input type="checkbox"/> Snags and Logs: Trees are considered snags if they are dead or dying and exhibit sufficient decay characteristics to enable cavity excavation/use by wildlife. Priority snags have a diameter at breast height of > 51 cm (20 in) in western Washington and are > 2 m (6.5 ft) in height. Priority logs are > 30 cm (12 in) in diameter at the largest end, and > 6 m (20 ft) long.</p> <p style="text-align: right;">If wetland has 3 or more priority habitats = 4 points If wetland has 2 priority habitats = 3 points If wetland has 1 priority habitat = 1 point No habitats = 0 points</p> <p>Note: All vegetated wetlands are by definition a priority habitat but are not included in this list. Nearby wetlands are addressed in question H 2.4)</p>	0
	<p>H 2.4 <u>Wetland Landscape:</u> Choose the one description of the landscape around the wetland that best fits (see p. 84)</p> <ul style="list-style-type: none"> • There are at least 3 other wetlands within 1/2 mile, and the connections between them are relatively undisturbed (light grazing between wetlands OK, as is lake shore with some boating, but connections should NOT be bisected by paved roads, fill, fields, or other development.... points = 5 <input type="checkbox"/> • The wetland is Lake-fringe on a lake with little disturbance and there are 3 other lake-fringe wetlands within 1/2 mile points = 5 <input type="checkbox"/> • There are at least 3 other wetlands within 1/2 mile, BUT the connections between them are disturbed. points = 3 <input checked="" type="checkbox"/> • The wetland fringe on a lake with disturbance and there are 3 other lake-fringe wetlands within 1/2 mile points = 3 <input type="checkbox"/> • There is at least 1 wetland within 1/2 mile points = 2 <input type="checkbox"/> • There are no wetlands within 1/2 mile..... points = 0 <input type="checkbox"/> 	3
	<p>H 2 TOTAL Score – opportunity for providing habitat Add the scores from H2.1, H2.2, H2.3, H2.4</p>	4
	<p style="text-align: right;">TOTAL for H 1 from page 8</p>	7
◆	<p>Total Score for Habitat Functions Add the points for H 1 and H 2; then record the result on p. 1</p>	11

Comments: _____

CATEGORIZATION BASED ON SPECIAL CHARACTERISTICS

Please determine if the wetland meets the attributes described below and circle the appropriate answers and Category.

Wetland Type – Check off any criteria that apply to the wetland. Circle the Category when the appropriate criteria are met.	
SC1	<p>Estuarine wetlands? (see p.86)</p> <p>Does the wetland unit meet the following criteria for Estuarine wetlands?</p> <p><input type="checkbox"/> The dominant water regime is tidal, <input type="checkbox"/> Vegetated, and <input type="checkbox"/> With a salinity greater than 0.5 ppt.</p> <p style="text-align: right;"><input type="checkbox"/> YES = Go to SC 1.1 <input checked="" type="checkbox"/> NO</p>
	<p>SC 1.1 Is the wetland unit within a National Wildlife Refuge, National Park, National Estuary Reserve, Natural Area Preserve, State Park or Educational, Environmental, or Scientific Reserve designated under WAC 332-30-151? <input type="checkbox"/> YES = Category I <input type="checkbox"/> NO = go to SC 1.2</p>
	<p>SC 1.2 Is the wetland at least 1 acre in size and meets at least two of the following conditions?</p> <p style="text-align: right;"><input type="checkbox"/> YES = Category I <input type="checkbox"/> NO = Category II</p> <p><input type="checkbox"/> The wetland is relatively undisturbed (has no diking, ditching, filling, cultivation, grazing, and has less than 10% cover of non-native plant species. If the non-native <i>Spartina</i> spp. are only species that cover more than 10% of the wetland, then the wetland should be given a dual rating (I/II). The area of <i>Spartina</i> would be rated a Category II while the relatively undisturbed upper marsh with native species would be a Category I. Do not, however, exclude the area of <i>Spartina</i> in determining the size threshold of 1 acre.</p> <p><input type="checkbox"/> At least 3/4 of the landward edge of the wetland has a 100 ft. buffer of shrub, forest, or un-grazed or un-mowed grassland</p> <p><input type="checkbox"/> The wetland has at least 2 of the following features: tidal channels, depressions with open water, or contiguous freshwater wetlands.</p>
SC2	<p>Natural Heritage Wetlands (see p. 87)</p> <p>Natural Heritage wetlands have been identified by the Washington Natural Heritage Program/DNR as either high quality undisturbed wetlands or wetlands that support state Threatened, Endangered, or Sensitive plant species.</p> <p>SC 2.1 Is the wetland being rated in a Section/Township/Range that contains a natural heritage wetland? (This question is used to screen out most sites before you need to contact WNHP/DNR.)</p> <p style="text-align: right;"><input type="checkbox"/> S/T/R information from Appendix D <input type="checkbox"/> or accessed from WNHP/DNR web site <input type="checkbox"/> YES Contact WNHP/DNR (see p. 79) and go to SC 2.2 <input checked="" type="checkbox"/> NO</p> <p>SC 2.2 Has DNR identified the wetland as a high quality undisturbed wetland or as a site with state threatened or endangered plant species?</p> <p style="text-align: right;"><input type="checkbox"/> YES = Category 1 <input checked="" type="checkbox"/> NO not a Heritage Wetland</p>
SC3	<p>Bogs (see p. 87)</p> <p>Does the wetland (or any part of the unit) meet both the criteria for soils and vegetation in bogs? Use the key below to identify if the wetland is a bog. If you answer yes you will still need to rate the wetland based on its function.</p> <ol style="list-style-type: none"> Does the unit have organic soil horizons (i.e. layers of organic soil), either peats or mucks, that compose 16 inches or more of the first 32 inches of soil profile? (See Appendix B for a field key to identify organic soils)? <input type="checkbox"/> YES = go to question 3 <input checked="" type="checkbox"/> NO = go to question 2 Does the wetland have organic soils, either peats or mucks that are less than 16 inches deep over bedrock, or an impermeable hardpan such as clay or volcanic ash, or that are floating on a lake or pond? <input type="checkbox"/> YES = go to question 3 <input checked="" type="checkbox"/> NO = is not a bog for purpose of rating Does the unit have more than 70% cover of mosses at ground level, AND other plants, if present, consist of the “bog” species listed in Table 3 as a significant component of the vegetation (more than 30% of the total shrub and herbaceous cover consists of species in Table 3)? <p style="text-align: right;"><input type="checkbox"/> YES = Is a bog for purpose of rating <input checked="" type="checkbox"/> NO = go to question 4</p> <p>NOTE: If you are uncertain about the extent of mosses in the understory you may substitute that criterion by measuring the pH of the water that seeps into a hole dug at least 16” deep. If the pH is less than 5.0 and the “bog” plant species in Table 3 are present, the wetland is a bog.</p> <ol style="list-style-type: none"> Is the unit forested (> 30% cover) with sitka spruce, subalpine fir, western red cedar, western hemlock, lodgepole pine, quaking aspen, Englemann’s spruce, or western white pine. WITH any of the species (or combination of species) on the bog species plant list in Table 3 as a significant component of the ground cover (> 30% coverage of the total shrub/herbaceous cover)? <p style="text-align: right;"><input type="checkbox"/> YES = Category I <input checked="" type="checkbox"/> NO = Is not a bog for purpose of rating</p>
	<p>Cat. I <input type="checkbox"/></p> <p>Cat. II <input type="checkbox"/></p> <p>Dual Rating I/II <input type="checkbox"/></p> <p>Cat I <input type="checkbox"/></p> <p>Cat. I <input type="checkbox"/></p>

SC4	<p>Forested Wetlands (see p. 90)</p> <p>Does the wetland have at least 1 acre of forest that meet one of these criteria for the Department of Fish and Wildlife’s forests as priority habitats? <i>If you answer yes you will still need to rate the wetland based on its function.</i></p> <p><input type="checkbox"/> Old-growth forests: (west of Cascade Crest) Stands of at least two three species forming a multi-layered canopy with occasional small openings; with at least 8 trees/acre (20 trees/hectare) that are at least 200 years of age OR have a diameter at breast height (dbh) of 32 inches (81 cm or more). NOTE: The criterion for dbh is based on measurements for upland forests. Two-hundred year old trees in wetlands will often have a smaller dbh because their growth rates are often slower. The DFW criterion is and “OR” so old-growth forests do not necessarily have to have trees of this diameter.</p> <p><input type="checkbox"/> Mature forests: (west of the Cascade Crest) Stands where the largest trees are 80 – 200 years old OR have an average diameters (dbh) exceeding 21 inches (53 cm); crown cover may be less than 100%; decay, decadence, numbers of snags, and quantity of large downed material is generally less than that found in old-growth.</p> <p><input type="checkbox"/> YES = Category I <input checked="" type="checkbox"/> NO = not a forested wetland with special characteristics</p>	<p>Cat. I <input type="checkbox"/></p>
SC5	<p>Wetlands in Coastal Lagoons (see p. 91)</p> <p>Does the wetland meet all of the following criteria of a wetland in a coastal lagoon?</p> <p><input type="checkbox"/> The wetland lies in a depression adjacent to marine waters that is wholly or partially separated from marine waters by sandbanks, gravel banks, shingle, or, less frequently, rocks.</p> <p><input type="checkbox"/> The lagoon in which the wetland is located contains surface water that is saline or brackish (> 0.5 ppt) during most of the year in at least a portion of the lagoon (<i>needs to be measured near the bottom.</i>)</p> <p><input type="checkbox"/> YES = Go to SC 5.1 <input checked="" type="checkbox"/> NO not a wetland in a coastal lagoon</p> <p>SC 5.1 Does the wetland meet all of the following three conditions?</p> <p><input type="checkbox"/> The wetland is relatively undisturbed (has no diking, ditching, filling, cultivation, grazing) and has less than 20% cover of invasive plant species (see list of invasive species on p. 74).</p> <p><input type="checkbox"/> At least 3/4 of the landward edge of the wetland has a 100 ft. buffer of shrub, forest, or un-grazed or un-mowed grassland.</p> <p><input type="checkbox"/> The wetland is larger than 1/10 acre (4350 square ft.)</p> <p><input type="checkbox"/> YES = Category I <input type="checkbox"/> NO = Category II</p>	<p style="background-color: #cccccc;"> </p> <p>Cat. I <input type="checkbox"/></p> <p>Cat. II <input type="checkbox"/></p>
SC6	<p>Interdunal Wetlands (see p. 93)</p> <p>Is the wetland west of the 1889 line (also called the Western Boundary of Upland Ownership or WBUO)?</p> <p><input type="checkbox"/> YES = Go to SC 6.1 <input checked="" type="checkbox"/> NO not an interdunal wetland for rating</p> <p><i>If you answer yes you will still need to rate the wetland based on its functions.</i></p> <p>In practical terms that means the following geographic areas:</p> <ul style="list-style-type: none"> • Long Beach Peninsula -- lands west of SR 103 • Grayland-Westport -- lands west of SR 105 • Ocean Shores-Copalis – lands west of SR 115 and SR 109 <p>SC 6.1 Is the wetland one acre or larger, or is it in a mosaic of wetlands that is one acre or larger?</p> <p><input type="checkbox"/> YES = Category II <input type="checkbox"/> NO = go to SC 6.2</p> <p>SC 6.2 Is the wetland between 0.1 and 1 acre, or is it in a mosaic of wetlands that is between 0.1 and 1 acre?</p> <p><input type="checkbox"/> YES = Category III</p>	<p>Cat. II <input type="checkbox"/></p> <p>Cat. III <input type="checkbox"/></p>
◆	<p>Category of wetland based on Special Characteristics</p> <p>Choose the “highest” rating if wetland falls into several categories, and record on p. 1. If you answered NO for all types enter “Not Applicable” on p. 1</p>	<p>NA</p>

Comments:

WETLAND RATING FORM – WESTERN WASHINGTON
Version 2 – Updated July 2006 to increase accuracy and reproducibility among users
Updated Oct. 2008 with the new WDFW definitions for priority habitats

Name of wetland (if known): DPUHP qvj

Date of site visit: May 15, 2013

Rated by: C. Douglas & J. Pursley Trained by Ecology? Yes No

Date of training: May 2007

SEC: 29 TOWNSHP: 24N RNGE: 5E

Is S/T/R in Appendix D? Yes No

Map of wetland unit: Figure _____ Estimated size _____

SUMMARY OF RATING

Category based on FUNCTIONS provided by wetland: I II III IV

Category I =	Score > 70
Category II =	Score 51 - 69
Category III =	Score 30 – 50
Category IV =	Score < 30

Score for Water Quality Functions	14
Score for Hydrologic Functions	16
Score for Habitat Functions	10
TOTAL Score for Functions	40

Category based on SPECIAL CHARACTERISTICS of Wetland I II Does not apply

Final Category (choose the “highest” category from above”)

III

Summary of basic information about the wetland unit.

Wetland Unit has Special Characteristics		Wetland HGM Class used for Rating	
Estuarine	<input type="checkbox"/>	Depressional	<input checked="" type="checkbox"/>
Natural Heritage Wetland	<input type="checkbox"/>	Riverine	<input type="checkbox"/>
Bog	<input type="checkbox"/>	Lake-fringe	<input type="checkbox"/>
Mature Forest	<input type="checkbox"/>	Slope	<input checked="" type="checkbox"/>
Old Growth Forest	<input type="checkbox"/>	Flats	<input type="checkbox"/>
Coastal Lagoon	<input type="checkbox"/>	Freshwater Tidal	<input type="checkbox"/>
Interdunal	<input type="checkbox"/>		<input type="checkbox"/>
None of the above	<input checked="" type="checkbox"/>	Check if unit has multiple HGM classes present	<input checked="" type="checkbox"/>

Does the wetland being rated meet any of the criteria below? If you answer YES to any of the questions below you will need to protect the wetland according to the regulations regarding the special characteristics found in the wetland.

Check List for Wetlands that Need Additional Protection (in addition to the protection recommended for its category)	YES	NO
SP1. <i>Has the wetland unit been documented as a habitat for any Federally listed Threatened or Endangered animal or plant species (T/E species)?</i> For the purposes of this rating system, “documented” means the wetland is on the appropriate state or federal database.	<input type="checkbox"/>	<input checked="" type="checkbox"/>
SP2. <i>Has the wetland unit been documented as habitat for any State listed Threatened or Endangered animal species?</i> For the purposes of this rating system, “documented” means the wetland is on the appropriate state database. Note: Wetlands with State listed plant species are categorized as Category 1 Natural Heritage Wetlands (see p. 19 of data form).	<input type="checkbox"/>	<input checked="" type="checkbox"/>
SP3. <i>Does the wetland unit contain individuals of Priority species listed by the WDFW for the state?</i>	<input type="checkbox"/>	<input checked="" type="checkbox"/>
SP4. <i>Does the wetland unit have a local significance in addition to its functions?</i> For example, the wetland has been identified in the Shoreline Master Program, the Critical Areas Ordinance, or in a local management plan as having special significance.	<input type="checkbox"/>	<input checked="" type="checkbox"/>

To complete the next part of the data sheet you will need to determine the Hydrogeomorphic Class of the wetland being rated.

The hydrogeomorphic classification groups wetlands in to those that function in similar ways. This simplifies the questions needed to answer how well the wetland functions. The Hydrogeomorphic Class of a wetland can be determined using the key below. See p. 24 for more detailed instructions on classifying wetlands.

Classification of Vegetated Wetlands for Western Washington

If the hydrologic criteria listed in each question do not apply to the entire unit being rated, you probably have a unit with multiple HGM classes. In this case, identify which hydrologic criteria in questions 1-7 apply, and go to Question 8.

1. Are the water levels in the entire unit usually controlled by tides (i.e. except during floods)?
 NO – go to 2 **YES** – the wetland class is **Tidal Fringe**
 If yes, is the salinity of the water during periods of annual low flow below 0.5 ppt (parts per thousand)?
 YES – **Freshwater Tidal Fringe** **NO** – **Saltwater Tidal Fringe (Estuarine)**
*If your wetland can be classified as a Freshwater Tidal Fringe use the forms for **Riverine** wetlands. If it is a Saltwater Tidal Fringe it is rated as an **Estuarine** wetland. Wetlands that were call estuarine in the first and second editions of the rating system are called Salt Water Tidal Fringe in the Hydrogeomorphic Classification. Estuarine wetlands were categorized separately in the earlier editions, and this separation is being kept in this revision. To maintain consistency between editions, the term “Estuarine” wetland is kept. Please note, however, that the characteristics that define Category I and II estuarine wetlands have changed (see p. _____).*
-
2. The entire wetland unit is flat and precipitation is only source (>90%) of water to it. Groundwater and surface water runoff are NOT sources of water to the unit.
 NO – go to 3 **YES** – The wetland class is **Flats**
 If your wetland can be classified as a “Flats” wetland, use the form for **Depressional** wetlands.
-
3. Does the entire wetland meet both of the following criteria?
 The vegetated part of the wetland is on the shores of a body of permanent open water (without any vegetation on the surface) where at least 20 acres (8ha) in size;
 At least 30% of the open water area is deeper than 6.6 (2 m)?
 NO – go to 4 **YES** – The wetland class is **Lake-fringe (Lacustrine Fringe)**
-
4. Does the entire wetland meet all of the following criteria?
 The wetland is on a slope (*slope can be very gradual*).
 The water flows through the wetland in one direction (unidirectional) and usually comes from seeps. It may flow subsurface, as sheetflow, or in a swale without distinct banks.
 The water leaves the wetland **without being impounded**?
 NOTE: *Surface water does not pond in these types of wetlands except occasionally in very small and shallow depressions or behind hummocks (depressions are usually <3 ft diameter and less than 1 foot deep).*
 NO – go to 5 **YES** – The wetland class is **Slope**
-
5. Does the entire wetland meet all of the following criteria?
 The unit is in a valley or stream channel where it gets inundated by overbank flooding from that stream or river.
 The overbank flooding occurs at least once every two years.
 NOTE: *The riverine unit can contain depressions that are filled with water when the river is not flooding..*
 NO – go to 6 **YES** – The wetland class is **Riverine**
-
6. Is the entire wetland unit in a topographic depression in which water ponds, or is saturated to the surface, at some time of the year. This means that any outlet, if present is higher than the interior of the wetland.
 NO – go to 7 **YES** – The wetland class is **Depressional**
-
7. Is the entire wetland located in a very flat area with no obvious depression and no overbank flooding. The unit does not pond surface water more than a few inches. The unit seems to be maintained by high groundwater in the area. The wetland may be ditched, but has no obvious natural outlet.
 No – go to 8 **YES** – The wetland class is **Depressional**
-
8. Your wetland unit seems to be difficult to classify and probably contains several different HGM classes. For example, seeps at the base of a slope may grade into a riverine floodplain, or a small stream within a depressional wetland has a zone of flooding along its sides. GO BACK AND IDENTIFY WHICH OF THE HYDROLOGIC REGIMES DESCRIBED IN QUESTIONS 1-7 APPLY TO DIFFERENT AREAS IN THE UNIT (make a rough sketch to help you decide). Use the following table to identify the appropriate class to use for the rating system if you have several HGM classes present within your wetland. NOTE: Use this table only if the class that is recommended in the second column represents 10% or more of the total area of the wetland unit being rated. If the area of the class listed in column 2 is less than 10% of the unit, classify the wetland using the class that represents more than 90% of the total area.

HGM Classes within the wetland unit being rated	HGM Class to Use in Rating
Slope + Riverine	Riverine
Slope + Depressional	Depressional
Slope + Lake-fringe	Lake-fringe
Depressional + Riverine along stream within boundary	Depressional
Depressional + Lake-fringe	Depressional
Salt Water Tidal Fringe and any other class of freshwater wetland	Treat as ESTUARINE under wetlands with special characteristics

If you are unable still to determine which of the above criteria apply to your wetland, or you have more than 2 HGM classes within a wetland boundary, classify the wetland as **Depressional** for the rating.

D Depressional and Flat Wetlands		Points
WATER QUALITY FUNCTIONS – Indicators that wetland functions to improve water quality.		(only 1 score per box) (see p.38)
D 1	Does the wetland have the <u>potential</u> to improve water quality?	
D 1.1	Characteristics of surface water flows out of the wetland: • Unit is a depression with no surface water leaving it (no outlet) points = 3 <input type="checkbox"/> • Unit has an intermittently flowing, OR highly constricted, permanently flowing outlet ... points = 2 <input checked="" type="checkbox"/> • Unit has an unconstricted, or slightly constricted, surface outlet (<i>permanently flowing</i>) .. points = 1 <input type="checkbox"/> • Unit is a “flat” depression (Q.7 on key), or in the Flats class, with permanent surface outflow and no obvious natural outlet and/or outlet is a man-made ditch..... points = 1 <input type="checkbox"/> <i>(If ditch is not permanently flowing treat unit as “intermittently flowing”)</i> Provide photo or drawing	Figure <input type="checkbox"/> 2
D 1.2	The soil 2 inches below the surface (or duff layer) is clay or organic (<i>use NRCS definitions</i>) YES points = 4 NO points = 0	0
D 1.3	Characteristics of persistent vegetation (emergent, shrub, and/or forest Cowardin class): • Wetland has persistent, ungrazed vegetation > = 95% of area points = 5 <input type="checkbox"/> • Wetland has persistent, ungrazed vegetation > = 1/2 of area points = 3 <input type="checkbox"/> • Wetland has persistent, ungrazed vegetation > = 1/10 of area points = 1 <input checked="" type="checkbox"/> • Wetland has persistent, ungrazed vegetation < 1/10 of area points = 0 <input type="checkbox"/> Map of Cowardin vegetation classes	Figure <input type="checkbox"/> 1
D 1.4	Characteristics of seasonal ponding or inundation: <i>This is the area of the wetland that is ponded for at least 2 months, but dries out sometime during the year. Do not count the area that is permanently ponded. Estimate area as the average condition 5 out of 10 years.</i> • Area seasonally ponded is > 1/2 total area of wetland points = 4 <input checked="" type="checkbox"/> • Area seasonally ponded is > 1/4 total area of wetland points = 2 <input type="checkbox"/> • Area seasonally ponded is < 1/4 total area of wetland points = 0 <input type="checkbox"/> Map of Hydroperiods	Figure <input type="checkbox"/> 4
Total for D 1		<i>Add the points in the boxes above</i> 7
D 2	Does the wetland have the <u>opportunity</u> to improve water quality?	(see p. 44)
Answer YES if you know or believe there are pollutants in groundwater or surface water coming into the wetland that would otherwise reduce water quality in streams, lakes or groundwater downgradient from the wetland? <i>Note which of the following conditions provide the sources of pollutants. A unit may have pollutants coming from several sources, but any single source would qualify as opportunity.</i> <input type="checkbox"/> Grazing in the wetland or within 150 ft <input checked="" type="checkbox"/> Untreated stormwater discharges to wetland <input type="checkbox"/> Tilled fields or orchards within 150 ft. of wetland <input checked="" type="checkbox"/> A stream or culvert discharges into wetland that drains developed areas, residential areas, farmed fields, roads, or clear-cut logging <input checked="" type="checkbox"/> Residential, urban areas, golf courses are within 150 ft. of wetland <input type="checkbox"/> Wetland is fed by groundwater high in phosphorus or nitrogen <input type="checkbox"/> Other _____		Multiplier 2
<input checked="" type="checkbox"/> YES multiplier is 2 <input type="checkbox"/> NO multiplier is 1		
◆ TOTAL – Water Quality Functions Multiply the score from D1 by D2; then <i>add score to table on p. 1</i>		14
HYDROLOGIC FUNCTIONS – Indicators that wetland unit functions to reduce flooding and stream degradation.		
D 3	Does the wetland have the <u>potential</u> to reduce flooding and erosion?	(see p.46)
D 3.1	Characteristics of surface water flows out of the wetland unit • Unit is a depression with no surface water leaving it (no outlet) points = 4 <input type="checkbox"/> • Unit has an intermittently flowing, OR highly constricted permanently flowing outlet points = 2 <input checked="" type="checkbox"/> • Unit is a “flat” depression (Q.7 on key) or in the Flats class, with permanent surface outflow and no obvious natural outlet and/or outlet is a man-made ditch..... points = 1 <input type="checkbox"/> <i>(If ditch is not permanently flowing treat unit as “intermittently flowing”)</i> • Unit has an unconstricted, or slightly constricted, surface outlet (<i>permanently flowing</i>) points = 0	2
D 3.2	Depth of storage during wet periods. <i>Estimate the height of ponding above the bottom of the outlet. For units with no outlet measure from the surface of permanent water or deepest part (if dry).</i> • Marks of ponding are 3 ft. or more above the surface or bottom of the outlet points = 7 <input type="checkbox"/> • The wetland is a “headwater” wetland..... points = 5 <input type="checkbox"/> • Marks of ponding between 2 ft. to < 3 ft. from surface or bottom of outlet points = 5 <input type="checkbox"/> • Marks are at least 0.5 ft. to < 2 ft. from surface or bottom of outlet points = 3 <input checked="" type="checkbox"/> • Wetland is flat (yes to Q.2 or Q.7 on key) but has small depressions on the surface that trap water . points = 1 <input type="checkbox"/> • Marks of ponding less than 0.5 ft points = 0 <input type="checkbox"/>	3
D 3.3	Contribution of wetland unit to storage in the watershed: <i>Estimate the ratio of the area of upstream basin contributing surface water to the wetland to the area of the wetland unit itself.</i> • The area of the basin is less than 10 times the area of unit..... points = 5 <input type="checkbox"/> • The area of the basin is 10 to 100 times the area of the unit..... points = 3 <input checked="" type="checkbox"/> • The area of the basin is more than 100 times the area of the unit points = 0 <input type="checkbox"/> • Entire unit is in the FLATS class points = 5 <input type="checkbox"/>	3
Total for D 3		<i>Add the points in the boxes above</i> 8

These questions apply to wetlands of all HGM classes.		Points								
HABITAT FUNCTIONS – Indicators that wetland functions to provide important habitat.		(only 1 score per box)								
H 1	Does the wetland have the potential to provide habitat for many species?									
H 1.1	<p>Vegetation structure (see P. 72): Check the types of vegetation classes present (as defined by Cowardin) – Size threshold for each class is 1/4 acre or more than 10% of the area if unit is smaller than 2.5 acres.</p> <p><input type="checkbox"/> Aquatic Bed <input type="checkbox"/> Emergent plants <input checked="" type="checkbox"/> Scrub/shrub (areas where shrubs have > 30% cover) <input checked="" type="checkbox"/> Forested (areas where trees have > 30% cover)</p> <p>If the unit has a forested class check if: <input type="checkbox"/> The forested class has 3 out of 5 strata (canopy, sub-canopy, shrubs, herbaceous, moss/ground-cover) that each cover 20% within the forested polygon.</p> <p>Add the number of vegetation types that qualify. If you have: Map of Cowardin vegetation classes</p> <table style="width: 100%; border: none;"> <tr> <td style="width: 50%;">4 structures or more..... points = 4 <input type="checkbox"/></td> <td style="width: 50%;">3 structures..... points = 2 <input type="checkbox"/></td> </tr> <tr> <td>2 structures..... points = 1 <input checked="" type="checkbox"/></td> <td>1 structure..... points = 0 <input type="checkbox"/></td> </tr> </table>	4 structures or more..... points = 4 <input type="checkbox"/>	3 structures..... points = 2 <input type="checkbox"/>	2 structures..... points = 1 <input checked="" type="checkbox"/>	1 structure..... points = 0 <input type="checkbox"/>	<p>Figure <input type="checkbox"/></p> <p style="text-align: center;">1</p>				
4 structures or more..... points = 4 <input type="checkbox"/>	3 structures..... points = 2 <input type="checkbox"/>									
2 structures..... points = 1 <input checked="" type="checkbox"/>	1 structure..... points = 0 <input type="checkbox"/>									
H 1.2	<p>Hydroperiods (see p.73): Check the types of water regimes (hydroperiods) present within the wetland. The water regime has to cover more than 10% of the wetland or 1/4 acre to count (see text for descriptions of hydroperiods).</p> <table style="width: 100%; border: none;"> <tr> <td style="width: 50%;"><input type="checkbox"/> Permanently flooded or inundated</td> <td style="width: 50%;">4 or more types present points = 3 <input type="checkbox"/></td> </tr> <tr> <td><input checked="" type="checkbox"/> Seasonally flooded or inundated</td> <td>3 or more types present points = 2 <input type="checkbox"/></td> </tr> <tr> <td><input checked="" type="checkbox"/> Occasionally flooded or inundated</td> <td>2 types present points = 1 <input checked="" type="checkbox"/></td> </tr> <tr> <td><input checked="" type="checkbox"/> Saturated only</td> <td>1 type present points = 0 <input type="checkbox"/></td> </tr> </table> <p><input type="checkbox"/> Permanently flowing stream or river in, or adjacent to, the wetland <input type="checkbox"/> Seasonally flowing stream in, or adjacent to, the wetland</p> <p><input type="checkbox"/> Lake-fringe wetland..... = 2 points <input type="checkbox"/> Freshwater tidal wetland..... = 2 points</p> <p style="text-align: right;">Map of hydroperiods</p>	<input type="checkbox"/> Permanently flooded or inundated	4 or more types present points = 3 <input type="checkbox"/>	<input checked="" type="checkbox"/> Seasonally flooded or inundated	3 or more types present points = 2 <input type="checkbox"/>	<input checked="" type="checkbox"/> Occasionally flooded or inundated	2 types present points = 1 <input checked="" type="checkbox"/>	<input checked="" type="checkbox"/> Saturated only	1 type present points = 0 <input type="checkbox"/>	<p>Figure <input type="checkbox"/></p> <p style="text-align: center;">1</p>
<input type="checkbox"/> Permanently flooded or inundated	4 or more types present points = 3 <input type="checkbox"/>									
<input checked="" type="checkbox"/> Seasonally flooded or inundated	3 or more types present points = 2 <input type="checkbox"/>									
<input checked="" type="checkbox"/> Occasionally flooded or inundated	2 types present points = 1 <input checked="" type="checkbox"/>									
<input checked="" type="checkbox"/> Saturated only	1 type present points = 0 <input type="checkbox"/>									
H 1.3	<p>Richness of Plant Species (see p. 75): Count the number of plant species in the wetland that cover at least 10 ft² (different patches of the same species can be combined to meet the size threshold) You do not have to name the species. Do not include Eurasian Milfoil, reed canarygrass, purple loosestrife, Canadian Thistle.</p> <p>If you counted: > 19 species points = 2 <input type="checkbox"/> 5 – 19 species..... points = 1 <input checked="" type="checkbox"/> < 5 species points = 0 <input type="checkbox"/></p> <p>List species below if you want to:</p> <hr/>	<p style="text-align: center;">1</p>								
H 1.4	<p>Interspersion of Habitats (see p. 76): Decided from the diagrams below whether interspersion between Cowardin vegetation (described in H1.1), or the classes and unvegetated areas (can include open water or mudflats) is high, medium, low, or none.</p> <div style="text-align: center;"> <p>None = 0 points Low = 1 point Moderate = 2 points</p> <p>High = 3 points [riparian braided channels]</p> </div> <p>Note: If you have 4 or more classes or 3 vegetation classes and open water, the rating is always “high”.</p> <p style="text-align: right;">Use map of Cowardin classes.</p>	<p>Figure <input type="checkbox"/></p> <p style="text-align: center;">2</p>								
H 1.5	<p>Special Habitat Features (see p. 77): Check the habitat features that are present in the wetland. The number of checks is the number of points you put into the next column.</p> <p><input checked="" type="checkbox"/> Large, downed, woody debris within the wetland (> 4 in. diameter and 6 ft. long) <input type="checkbox"/> Standing snags (diameter at the bottom > 4 inches) in the wetland <input type="checkbox"/> Undercut banks are present for at least 6.6 ft. (2m) and/or overhanging vegetation extends at least 3.3 ft. (1m) over a stream (or ditch) in, or contiguous with the unit, for at least 33 ft. (10m) <input type="checkbox"/> Stable steep banks of fine material that might be used by beaver or muskrat for denning (> 30 degree slope) OR signs of recent beaver activity are present (cut shrubs or trees that have not yet turned grey/brown) <input type="checkbox"/> At least 1/4 acre of thin-stemmed persistent vegetation or woody branches are present in areas that are permanently or seasonally inundated (structures for egg-laying by amphibians) <input type="checkbox"/> Invasive plants cover less than 25% of the wetland area in each stratum of plants</p> <p>NOTE: The 20% stated in early printings of the manual on page 78 is an error.</p>	<p style="text-align: center;">1</p>								
H 1 TOTAL Score – potential for providing habitat		6								
Add the points in the column above										

H 2	Does the wetland have the <u>opportunity</u> to provide habitat for many species?	(only 1 score per box)
	<p>H 2.1 <u>Buffers</u> (see P. 80): Choose the description that best represents condition of buffer of wetland unit. The highest scoring criterion that applies to the wetland is to be used in the rating. See text for definition of "undisturbed".</p> <p><input type="checkbox"/> 100m (330 ft) of relatively undisturbed vegetated areas, rocky areas, or open water > 95% of circumference. No structures are within the undisturbed part of buffer (relatively undisturbed also means no grazing, no landscaping, no daily human use)..... points = 5</p> <p><input type="checkbox"/> 100m (330 ft) of relatively undisturbed vegetated areas, rocky areas, or open water > 50% circumference points = 4</p> <p><input type="checkbox"/> 50m (170 ft) of relatively undisturbed vegetated areas, rocky areas, or open water > 95% circumference points = 4</p> <p><input type="checkbox"/> 100m (330 ft) of relatively undisturbed vegetated areas, rocky areas, or open water > 25% circumference points = 3</p> <p><input type="checkbox"/> 50m (170 ft) of relatively undisturbed vegetated areas, rocky areas, or open water for > 50% circumference points = 3</p> <p>If buffer does not meet any of the criteria above:</p> <p><input type="checkbox"/> No paved areas (except paved trails) or buildings within 25m (80 ft) of wetland > 95% circumference. Light to moderate grazing or lawns are OK points = 2</p> <p><input type="checkbox"/> No paved areas of buildings within 50m of wetland for > 50% circumference. Light to moderate grazing or lawns are OK points = 2</p> <p><input type="checkbox"/> Heavy grazing in buffer points = 1</p> <p><input type="checkbox"/> Vegetated buffers are < 2m wide (6.6 ft) for more than 95% circumference (e.g. tilled fields, paving, basalt bedrock extend to edge of wetland) points = 0</p> <p><input checked="" type="checkbox"/> Buffer does not meet any of the criteria above points = 1</p> <p style="text-align: right;">Arial photo showing buffers</p>	<p>Figure <input type="checkbox"/></p> <p style="text-align: right;">1</p>
	<p>H 2.2 <u>Corridors and Connections</u> (see p. 81)</p> <p>H 2.2.1 Is the wetland part of a relatively undisturbed and unbroken vegetated corridor (either riparian or upland) that is at least 150 ft. wide, has at least a 30% cover of shrubs, forest or native undisturbed prairie, that connects to estuaries, other wetlands or undisturbed uplands that are at least 250 acres in size? (<i>Dams in riparian corridors, heavily used gravel roads, paved roads, are considered breaks in the corridor.</i>)</p> <p style="padding-left: 40px;"><input type="checkbox"/> YES = 4 points (go to H 2.3) <input checked="" type="checkbox"/> NO = go to H 2.2.2</p> <p>H. 2.2.2 Is the wetland part of a relatively undisturbed and unbroken vegetated corridor (either riparian or upland) that is at least 50 ft. wide, has at least 30% cover of shrubs or forest, and connects to estuaries, other wetlands or undisturbed uplands that are at least 25 acres in size? OR a Lake-fringe wetland, if it does not have an undisturbed corridor as in the question above?</p> <p style="padding-left: 40px;"><input type="checkbox"/> YES = 2 points (go to H 2.3) <input checked="" type="checkbox"/> NO = go to H 2.2.3</p> <p>H. 2.2.3 Is the wetland:</p> <ul style="list-style-type: none"> • Within 5 mi (8km) of a brackish or salt water estuary OR • Within 3 miles of a large field or pasture (> 40 acres) OR • Within 1 mile of a lake greater than 20 acres? <p style="text-align: right; padding-right: 40px;"><input type="checkbox"/> YES = 1 point <input checked="" type="checkbox"/> NO = 0 points</p>	<p style="text-align: right;">0</p>

Comments: _____

	<p>H 2.3 <u>Near or adjacent to other priority habitats listed by WDFW</u> (see p. 82): (see new and complete descriptions of WDFW priority habitats, and the counties in which they can be found, in the PHS report http://wdfw.wa.gov/hab/phslist.htm) Which of the following priority habitats are within 330 ft. (100m) of the wetland unit? <i>NOTE: the connections do not have to be relatively undisturbed.</i></p> <p><input type="checkbox"/> Aspen Stands: Pure or mixed stands of aspen greater than 0.4 ha (1 acre).</p> <p><input type="checkbox"/> Biodiversity Areas and Corridors: Areas of habitat that are relatively important to various species of native fish and wildlife (full descriptions in WDFW PHS report p. 152).</p> <p><input type="checkbox"/> Herbaceous Balds: Variable size patches of grass and forbs on shallow soils over bedrock.</p> <p><input type="checkbox"/> Old-growth/Mature forests: (Old-growth west of Cascade crest) Stands of at least 2 tree species, forming a multi-layered canopy with occasional small openings; with at least 20 trees/ha (8 trees/acre) > 81 cm (32 in) dbh or > 200 years of age. (Mature forests) Stands with average diameters exceeding 53 cm (21 in) dbh; crown cover may be less than 100%; decay, decadence, numbers of snags, and quantity of large downed material is generally less than that found in old-growth; 80 - 200 years old west of the Cascade crest.</p> <p><input type="checkbox"/> Oregon white Oak: Woodlands Stands of pure oak or oak/conifer associations where canopy coverage of the oak component is important (full descriptions in WDFW PHS report p. 158).</p> <p><input type="checkbox"/> Riparian: The area adjacent to aquatic systems with flowing water that contains elements of both aquatic and terrestrial ecosystems which mutually influence each other.</p> <p><input type="checkbox"/> Westside Prairies: Herbaceous, non-forested plant communities that can either take the form of a dry prairie or a wet prairie (full descriptions in WDFW PHS report p. 161).</p> <p><input type="checkbox"/> Instream: The combination of physical, biological, and chemical processes and conditions that interact to provide functional life history requirements for instream fish and wildlife resources.</p> <p><input type="checkbox"/> Nearshore: Relatively undisturbed nearshore habitats. These include Coastal Nearshore, Open Coast Nearshore, and Puget Sound Nearshore. (full descriptions of habitats and the definition of relatively undisturbed are in WDFW report: pp. 167-169 and glossary in Appendix A).</p> <p><input type="checkbox"/> Caves: A naturally occurring cavity, recess, void, or system of interconnected passages under the earth in soils, rock, ice, or other geological formations and is large enough to contain a human.</p> <p><input type="checkbox"/> Cliffs: Greater than 7.6 m (25 ft) high and occurring below 5000 ft.</p> <p><input type="checkbox"/> Talus: Homogenous areas of rock rubble ranging in average size 0.15 - 2.0 m (0.5 - 6.5 ft), composed of basalt, andesite, and/or sedimentary rock, including riprap slides and mine tailings. May be associated with cliffs.</p> <p><input type="checkbox"/> Snags and Logs: Trees are considered snags if they are dead or dying and exhibit sufficient decay characteristics to enable cavity excavation/use by wildlife. Priority snags have a diameter at breast height of > 51 cm (20 in) in western Washington and are > 2 m (6.5 ft) in height. Priority logs are > 30 cm (12 in) in diameter at the largest end, and > 6 m (20 ft) long.</p> <p style="text-align: right;">If wetland has 3 or more priority habitats = 4 points If wetland has 2 priority habitats = 3 points If wetland has 1 priority habitat = 1 point No habitats = 0 points</p> <p>Note: All vegetated wetlands are by definition a priority habitat but are not included in this list. Nearby wetlands are addressed in question H 2.4)</p>	0
	<p>H 2.4 <u>Wetland Landscape:</u> Choose the one description of the landscape around the wetland that best fits (see p. 84)</p> <ul style="list-style-type: none"> • There are at least 3 other wetlands within 1/2 mile, and the connections between them are relatively undisturbed (light grazing between wetlands OK, as is lake shore with some boating, but connections should NOT be bisected by paved roads, fill, fields, or other development.... points = 5 <input type="checkbox"/> • The wetland is Lake-fringe on a lake with little disturbance and there are 3 other lake-fringe wetlands within 1/2 mile points = 5 <input type="checkbox"/> • There are at least 3 other wetlands within 1/2 mile, BUT the connections between them are disturbed. points = 3 <input checked="" type="checkbox"/> • The wetland fringe on a lake with disturbance and there are 3 other lake-fringe wetlands within 1/2 mile points = 3 <input type="checkbox"/> • There is at least 1 wetland within 1/2 mile points = 2 <input type="checkbox"/> • There are no wetlands within 1/2 mile..... points = 0 <input type="checkbox"/> 	3
	<p>H 2 TOTAL Score – opportunity for providing habitat Add the scores from H2.1, H2.2, H2.3, H2.4</p>	4
	<p style="text-align: right;">TOTAL for H 1 from page 8</p>	6
◆	<p>Total Score for Habitat Functions Add the points for H 1 and H 2; then record the result on p. 1</p>	10

Comments: _____

CATEGORIZATION BASED ON SPECIAL CHARACTERISTICS

Please determine if the wetland meets the attributes described below and circle the appropriate answers and Category.

Wetland Type – Check off any criteria that apply to the wetland. Circle the Category when the appropriate criteria are met.	
SC1	<p>Estuarine wetlands? (see p.86)</p> <p>Does the wetland unit meet the following criteria for Estuarine wetlands?</p> <p><input type="checkbox"/> The dominant water regime is tidal, <input type="checkbox"/> Vegetated, and <input type="checkbox"/> With a salinity greater than 0.5 ppt.</p> <p style="text-align: center;"><input type="checkbox"/> YES = Go to SC 1.1 <input checked="" type="checkbox"/> NO</p>
	<p>SC 1.1 Is the wetland unit within a National Wildlife Refuge, National Park, National Estuary Reserve, Natural Area Preserve, State Park or Educational, Environmental, or Scientific Reserve designated under WAC 332-30-151? <input type="checkbox"/> YES = Category I <input type="checkbox"/> NO = go to SC 1.2</p>
	<p>SC 1.2 Is the wetland at least 1 acre in size and meets at least two of the following conditions?</p> <p style="text-align: center;"><input type="checkbox"/> YES = Category I <input type="checkbox"/> NO = Category II</p> <p><input type="checkbox"/> The wetland is relatively undisturbed (has no diking, ditching, filling, cultivation, grazing, and has less than 10% cover of non-native plant species. If the non-native <i>Spartina</i> spp. are only species that cover more than 10% of the wetland, then the wetland should be given a dual rating (I/II). The area of <i>Spartina</i> would be rated a Category II while the relatively undisturbed upper marsh with native species would be a Category I. Do not, however, exclude the area of <i>Spartina</i> in determining the size threshold of 1 acre.</p> <p><input type="checkbox"/> At least 3/4 of the landward edge of the wetland has a 100 ft. buffer of shrub, forest, or un-grazed or un-mowed grassland</p> <p><input type="checkbox"/> The wetland has at least 2 of the following features: tidal channels, depressions with open water, or contiguous freshwater wetlands.</p>
SC2	<p>Natural Heritage Wetlands (see p. 87)</p> <p>Natural Heritage wetlands have been identified by the Washington Natural Heritage Program/DNR as either high quality undisturbed wetlands or wetlands that support state Threatened, Endangered, or Sensitive plant species.</p> <p>SC 2.1 Is the wetland being rated in a Section/Township/Range that contains a natural heritage wetland? (This question is used to screen out most sites before you need to contact WNHP/DNR.)</p> <p style="text-align: center;"><input type="checkbox"/> S/T/R information from Appendix D <input type="checkbox"/> or accessed from WNHP/DNR web site <input type="checkbox"/> YES Contact WNHP/DNR (see p. 79) and go to SC 2.2 <input checked="" type="checkbox"/> NO</p> <p>SC 2.2 Has DNR identified the wetland as a high quality undisturbed wetland or as a site with state threatened or endangered plant species?</p> <p style="text-align: center;"><input type="checkbox"/> YES = Category 1 <input checked="" type="checkbox"/> NO not a Heritage Wetland</p>
SC3	<p>Bogs (see p. 87)</p> <p>Does the wetland (or any part of the unit) meet both the criteria for soils and vegetation in bogs? Use the key below to identify if the wetland is a bog. If you answer yes you will still need to rate the wetland based on its function.</p> <ol style="list-style-type: none"> Does the unit have organic soil horizons (i.e. layers of organic soil), either peats or mucks, that compose 16 inches or more of the first 32 inches of soil profile? (See Appendix B for a field key to identify organic soils)? <input type="checkbox"/> YES = go to question 3 <input checked="" type="checkbox"/> NO = go to question 2 Does the wetland have organic soils, either peats or mucks that are less than 16 inches deep over bedrock, or an impermeable hardpan such as clay or volcanic ash, or that are floating on a lake or pond? <input type="checkbox"/> YES = go to question 3 <input checked="" type="checkbox"/> NO = is not a bog for purpose of rating Does the unit have more than 70% cover of mosses at ground level, AND other plants, if present, consist of the “bog” species listed in Table 3 as a significant component of the vegetation (more than 30% of the total shrub and herbaceous cover consists of species in Table 3)? <p style="text-align: center;"><input type="checkbox"/> YES = Is a bog for purpose of rating <input checked="" type="checkbox"/> NO = go to question 4</p> <p>NOTE: If you are uncertain about the extent of mosses in the understory you may substitute that criterion by measuring the pH of the water that seeps into a hole dug at least 16” deep. If the pH is less than 5.0 and the “bog” plant species in Table 3 are present, the wetland is a bog.</p> <ol style="list-style-type: none"> Is the unit forested (> 30% cover) with sitka spruce, subalpine fir, western red cedar, western hemlock, lodgepole pine, quaking aspen, Englemann’s spruce, or western white pine. WITH any of the species (or combination of species) on the bog species plant list in Table 3 as a significant component of the ground cover (> 30% coverage of the total shrub/herbaceous cover)? <p style="text-align: center;"><input type="checkbox"/> YES = Category I <input checked="" type="checkbox"/> NO = Is not a bog for purpose of rating</p>
	<p>Cat. I <input type="checkbox"/></p> <p>Cat. II <input type="checkbox"/></p> <p>Dual Rating I/II <input type="checkbox"/></p> <p>Cat I <input type="checkbox"/></p> <p>Cat. I <input type="checkbox"/></p>

SC4	<p>Forested Wetlands (see p. 90)</p> <p>Does the wetland have at least 1 acre of forest that meet one of these criteria for the Department of Fish and Wildlife’s forests as priority habitats? <i>If you answer yes you will still need to rate the wetland based on its function.</i></p> <p><input type="checkbox"/> Old-growth forests: (west of Cascade Crest) Stands of at least two three species forming a multi-layered canopy with occasional small openings; with at least 8 trees/acre (20 trees/hectare) that are at least 200 years of age OR have a diameter at breast height (dbh) of 32 inches (81 cm or more). NOTE: The criterion for dbh is based on measurements for upland forests. Two-hundred year old trees in wetlands will often have a smaller dbh because their growth rates are often slower. The DFW criterion is and “OR” so old-growth forests do not necessarily have to have trees of this diameter.</p> <p><input type="checkbox"/> Mature forests: (west of the Cascade Crest) Stands where the largest trees are 80 – 200 years old OR have an average diameters (dbh) exceeding 21 inches (53 cm); crown cover may be less than 100%; decay, decadence, numbers of snags, and quantity of large downed material is generally less than that found in old-growth.</p> <p><input type="checkbox"/> YES = Category I <input checked="" type="checkbox"/> NO = not a forested wetland with special characteristics</p>	<p>Cat. I <input type="checkbox"/></p>
SC5	<p>Wetlands in Coastal Lagoons (see p. 91)</p> <p>Does the wetland meet all of the following criteria of a wetland in a coastal lagoon?</p> <p><input type="checkbox"/> The wetland lies in a depression adjacent to marine waters that is wholly or partially separated from marine waters by sandbanks, gravel banks, shingle, or, less frequently, rocks.</p> <p><input type="checkbox"/> The lagoon in which the wetland is located contains surface water that is saline or brackish (> 0.5 ppt) during most of the year in at least a portion of the lagoon (<i>needs to be measured near the bottom.</i>)</p> <p><input type="checkbox"/> YES = Go to SC 5.1 <input checked="" type="checkbox"/> NO not a wetland in a coastal lagoon</p> <p>SC 5.1 Does the wetland meet all of the following three conditions?</p> <p><input type="checkbox"/> The wetland is relatively undisturbed (has no diking, ditching, filling, cultivation, grazing) and has less than 20% cover of invasive plant species (see list of invasive species on p. 74).</p> <p><input type="checkbox"/> At least 3/4 of the landward edge of the wetland has a 100 ft. buffer of shrub, forest, or un-grazed or un-mowed grassland.</p> <p><input type="checkbox"/> The wetland is larger than 1/10 acre (4350 square ft.)</p> <p><input type="checkbox"/> YES = Category I <input type="checkbox"/> NO = Category II</p>	<p style="background-color: #cccccc;"> </p> <p>Cat. I <input type="checkbox"/></p> <p>Cat. II <input type="checkbox"/></p>
SC6	<p>Interdunal Wetlands (see p. 93)</p> <p>Is the wetland west of the 1889 line (also called the Western Boundary of Upland Ownership or WBUO)?</p> <p><input type="checkbox"/> YES = Go to SC 6.1 <input checked="" type="checkbox"/> NO not an interdunal wetland for rating</p> <p><i>If you answer yes you will still need to rate the wetland based on its functions.</i></p> <p>In practical terms that means the following geographic areas:</p> <ul style="list-style-type: none"> • Long Beach Peninsula -- lands west of SR 103 • Grayland-Westport -- lands west of SR 105 • Ocean Shores-Copalis – lands west of SR 115 and SR 109 <p>SC 6.1 Is the wetland one acre or larger, or is it in a mosaic of wetlands that is one acre or larger?</p> <p><input type="checkbox"/> YES = Category II <input type="checkbox"/> NO = go to SC 6.2</p> <p>SC 6.2 Is the wetland between 0.1 and 1 acre, or is it in a mosaic of wetlands that is between 0.1 and 1 acre?</p> <p><input type="checkbox"/> YES = Category III</p>	<p>Cat. II <input type="checkbox"/></p> <p>Cat. III <input type="checkbox"/></p>
◆	<p>Category of wetland based on Special Characteristics</p> <p>Choose the “highest” rating if wetland falls into several categories, and record on p. 1. If you answered NO for all types enter “Not Applicable” on p. 1</p>	<p>NA</p>

Comments:

WETLAND RATING FORM – WESTERN WASHINGTON
 Version 2 – Updated July 2006 to increase accuracy and reproducibility among users
 Updated Oct. 2008 with the new WDFW definitions for priority habitats

Name of wetland (if known): BNSF Northeast

Date of site visit: May 15, 2013

Rated by: C. Douglas & J. Pursley Trained by Ecology? Yes No

Date of training: May 2007

SEC: 29 TOWNSHP: 24N RNGE: 5E

Is S/T/R in Appendix D? Yes No

Map of wetland unit: Figure _____ Estimated size _____

SUMMARY OF RATING

Category based on FUNCTIONS provided by wetland: I II III IV

Category I =	Score > 70
Category II =	Score 51 - 69
Category III =	Score 30 – 50
Category IV =	Score < 30

Score for Water Quality Functions	14
Score for Hydrologic Functions	16
Score for Habitat Functions	10
TOTAL Score for Functions	40

Category based on SPECIAL CHARACTERISTICS of Wetland I II Does not apply

Final Category (choose the “highest” category from above”)

III

Summary of basic information about the wetland unit.

Wetland Unit has Special Characteristics		Wetland HGM Class used for Rating	
Estuarine	<input type="checkbox"/>	Depressional	<input checked="" type="checkbox"/>
Natural Heritage Wetland	<input type="checkbox"/>	Riverine	<input type="checkbox"/>
Bog	<input type="checkbox"/>	Lake-fringe	<input type="checkbox"/>
Mature Forest	<input type="checkbox"/>	Slope	<input type="checkbox"/>
Old Growth Forest	<input type="checkbox"/>	Flats	<input type="checkbox"/>
Coastal Lagoon	<input type="checkbox"/>	Freshwater Tidal	<input type="checkbox"/>
Interdunal	<input type="checkbox"/>		<input type="checkbox"/>
None of the above	<input checked="" type="checkbox"/>	Check if unit has multiple HGM classes present	<input type="checkbox"/>

Does the wetland being rated meet any of the criteria below? If you answer YES to any of the questions below you will need to protect the wetland according to the regulations regarding the special characteristics found in the wetland.

Check List for Wetlands that Need Additional Protection (in addition to the protection recommended for its category)	YES	NO
SP1. <i>Has the wetland unit been documented as a habitat for any Federally listed Threatened or Endangered animal or plant species (T/E species)?</i> For the purposes of this rating system, “documented” means the wetland is on the appropriate state or federal database.	<input type="checkbox"/>	<input checked="" type="checkbox"/>
SP2. <i>Has the wetland unit been documented as habitat for any State listed Threatened or Endangered animal species?</i> For the purposes of this rating system, “documented” means the wetland is on the appropriate state database. Note: Wetlands with State listed plant species are categorized as Category 1 Natural Heritage Wetlands (see p. 19 of data form).	<input type="checkbox"/>	<input checked="" type="checkbox"/>
SP3. <i>Does the wetland unit contain individuals of Priority species listed by the WDFW for the state?</i>	<input type="checkbox"/>	<input checked="" type="checkbox"/>
SP4. <i>Does the wetland unit have a local significance in addition to its functions?</i> For example, the wetland has been identified in the Shoreline Master Program, the Critical Areas Ordinance, or in a local management plan as having special significance.	<input type="checkbox"/>	<input checked="" type="checkbox"/>

To complete the next part of the data sheet you will need to determine the Hydrogeomorphic Class of the wetland being rated.

The hydrogeomorphic classification groups wetlands in to those that function in similar ways. This simplifies the questions needed to answer how well the wetland functions. The Hydrogeomorphic Class of a wetland can be determined using the key below. See p. 24 for more detailed instructions on classifying wetlands.

Classification of Vegetated Wetlands for Western Washington

If the hydrologic criteria listed in each question do not apply to the entire unit being rated, you probably have a unit with multiple HGM classes. In this case, identify which hydrologic criteria in questions 1-7 apply, and go to Question 8.

1. Are the water levels in the entire unit usually controlled by tides (i.e. except during floods)?
 NO – go to 2 YES – the wetland class is **Tidal Fringe**
 If yes, is the salinity of the water during periods of annual low flow below 0.5 ppt (parts per thousand)?
 YES – **Freshwater Tidal Fringe** NO – **Saltwater Tidal Fringe (Estuarine)**
*If your wetland can be classified as a Freshwater Tidal Fringe use the forms for **Riverine** wetlands. If it is a Saltwater Tidal Fringe it is rated as an **Estuarine** wetland. Wetlands that were call estuarine in the first and second editions of the rating system are called Salt Water Tidal Fringe in the Hydrogeomorphic Classification. Estuarine wetlands were categorized separately in the earlier editions, and this separation is being kept in this revision. To maintain consistency between editions, the term “Estuarine” wetland is kept. Please note, however, that the characteristics that define Category I and II estuarine wetlands have changed (see p. _____).*
-
2. The entire wetland unit is flat and precipitation is only source (>90%) of water to it. Groundwater and surface water runoff are NOT sources of water to the unit.
 NO – go to 3 YES – The wetland class is **Flats**
 If your wetland can be classified as a “Flats” wetland, use the form for **Depressional** wetlands.
-
3. Does the entire wetland meet both of the following criteria?
 The vegetated part of the wetland is on the shores of a body of permanent open water (without any vegetation on the surface) where at least 20 acres (8ha) in size;
 At least 30% of the open water area is deeper than 6.6 (2 m)?
 NO – go to 4 YES – The wetland class is **Lake-fringe (Lacustrine Fringe)**
-
4. Does the entire wetland meet all of the following criteria?
 The wetland is on a slope (*slope can be very gradual*).
 The water flows through the wetland in one direction (unidirectional) and usually comes from seeps. It may flow subsurface, as sheetflow, or in a swale without distinct banks.
 The water leaves the wetland **without being impounded**?
 NOTE: *Surface water does not pond in these types of wetlands except occasionally in very small and shallow depressions or behind hummocks (depressions are usually <3 ft diameter and less than 1 foot deep).*
 NO – go to 5 YES – The wetland class is **Slope**
-
5. Does the entire wetland meet all of the following criteria?
 The unit is in a valley or stream channel where it gets inundated by overbank flooding from that stream or river.
 The overbank flooding occurs at least once every two years.
 NOTE: *The riverine unit can contain depressions that are filled with water when the river is not flooding..*
 NO – go to 6 YES – The wetland class is **Riverine**
-
6. Is the entire wetland unit in a topographic depression in which water ponds, or is saturated to the surface, at some time of the year. This means that any outlet, if present is higher than the interior of the wetland.
 NO – go to 7 YES – The wetland class is **Depressional**
-
7. Is the entire wetland located in a very flat area with no obvious depression and no overbank flooding. The unit does not pond surface water more than a few inches. The unit seems to be maintained by high groundwater in the area. The wetland may be ditched, but has no obvious natural outlet.
 No – go to 8 YES – The wetland class is **Depressional**
-
8. Your wetland unit seems to be difficult to classify and probably contains several different HGM classes. For example, seeps at the base of a slope may grade into a riverine floodplain, or a small stream within a depressional wetland has a zone of flooding along its sides. GO BACK AND IDENTIFY WHICH OF THE HYDROLOGIC REGIMES DESCRIBED IN QUESTIONS 1-7 APPLY TO DIFFERENT AREAS IN THE UNIT (make a rough sketch to help you decide). Use the following table to identify the appropriate class to use for the rating system if you have several HGM classes present within your wetland. NOTE: Use this table only if the class that is recommended in the second column represents 10% or more of the total area of the wetland unit being rated. If the area of the class listed in column 2 is less than 10% of the unit, classify the wetland using the class that represents more than 90% of the total area.

HGM Classes within the wetland unit being rated	HGM Class to Use in Rating
Slope + Riverine	Riverine
Slope + Depressional	Depressional
Slope + Lake-fringe	Lake-fringe
Depressional + Riverine along stream within boundary	Depressional
Depressional + Lake-fringe	Depressional
Salt Water Tidal Fringe and any other class of freshwater wetland	Treat as ESTUARINE under wetlands with special characteristics

If you are unable still to determine which of the above criteria apply to your wetland, or you have more than 2 HGM classes within a wetland boundary, classify the wetland as **Depressional** for the rating.

D Depressional and Flat Wetlands		Points
WATER QUALITY FUNCTIONS – Indicators that wetland functions to improve water quality.		(only 1 score per box) (see p.38)
D 1	Does the wetland have the <u>potential</u> to improve water quality?	
D 1.1	Characteristics of surface water flows out of the wetland: • Unit is a depression with no surface water leaving it (no outlet) points = 3 <input type="checkbox"/> • Unit has an intermittently flowing, OR highly constricted, permanently flowing outlet ... points = 2 <input checked="" type="checkbox"/> • Unit has an unconstricted, or slightly constricted, surface outlet (<i>permanently flowing</i>) .. points = 1 <input type="checkbox"/> • Unit is a “flat” depression (Q.7 on key), or in the Flats class, with permanent surface outflow and no obvious natural outlet and/or outlet is a man-made ditch..... points = 1 <input type="checkbox"/> <i>(If ditch is not permanently flowing treat unit as “intermittently flowing”)</i> Provide photo or drawing	Figure <input type="checkbox"/> 2
D 1.2	The soil 2 inches below the surface (or duff layer) is clay or organic (<i>use NRCS definitions</i>) YES points = 4 NO points = 0	0
D 1.3	Characteristics of persistent vegetation (emergent, shrub, and/or forest Cowardin class): • Wetland has persistent, ungrazed vegetation > = 95% of area points = 5 <input type="checkbox"/> • Wetland has persistent, ungrazed vegetation > = 1/2 of area points = 3 <input type="checkbox"/> • Wetland has persistent, ungrazed vegetation > = 1/10 of area points = 1 <input checked="" type="checkbox"/> • Wetland has persistent, ungrazed vegetation < 1/10 of area points = 0 <input type="checkbox"/> Map of Cowardin vegetation classes	Figure <input type="checkbox"/> 1
D 1.4	Characteristics of seasonal ponding or inundation: <i>This is the area of the wetland that is ponded for at least 2 months, but dries out sometime during the year. Do not count the area that is permanently ponded. Estimate area as the average condition 5 out of 10 years.</i> • Area seasonally ponded is > 1/2 total area of wetland points = 4 <input checked="" type="checkbox"/> • Area seasonally ponded is > 1/4 total area of wetland points = 2 <input type="checkbox"/> • Area seasonally ponded is < 1/4 total area of wetland points = 0 <input type="checkbox"/> Map of Hydroperiods	Figure <input type="checkbox"/> 4
Total for D 1		<i>Add the points in the boxes above</i> 7
D 2	Does the wetland have the <u>opportunity</u> to improve water quality?	(see p. 44)
Answer YES if you know or believe there are pollutants in groundwater or surface water coming into the wetland that would otherwise reduce water quality in streams, lakes or groundwater downgradient from the wetland? <i>Note which of the following conditions provide the sources of pollutants. A unit may have pollutants coming from several sources, but any single source would qualify as opportunity.</i> <input type="checkbox"/> Grazing in the wetland or within 150 ft <input checked="" type="checkbox"/> Untreated stormwater discharges to wetland <input type="checkbox"/> Tilled fields or orchards within 150 ft. of wetland <input checked="" type="checkbox"/> A stream or culvert discharges into wetland that drains developed areas, residential areas, farmed fields, roads, or clear-cut logging <input checked="" type="checkbox"/> Residential, urban areas, golf courses are within 150 ft. of wetland <input type="checkbox"/> Wetland is fed by groundwater high in phosphorus or nitrogen <input type="checkbox"/> Other _____ <input checked="" type="checkbox"/> YES multiplier is 2 <input type="checkbox"/> NO multiplier is 1		Multiplier 2
◆ TOTAL – Water Quality Functions Multiply the score from D1 by D2; then <i>add score to table on p. 1</i>		14
HYDROLOGIC FUNCTIONS – Indicators that wetland unit functions to reduce flooding and stream degradation.		
D 3	Does the wetland have the <u>potential</u> to reduce flooding and erosion?	(see p.46)
D 3.1	Characteristics of surface water flows out of the wetland unit • Unit is a depression with no surface water leaving it (no outlet) points = 4 <input type="checkbox"/> • Unit has an intermittently flowing, OR highly constricted permanently flowing outlet points = 2 <input checked="" type="checkbox"/> • Unit is a “flat” depression (Q.7 on key) or in the Flats class, with permanent surface outflow and no obvious natural outlet and/or outlet is a man-made ditch..... points = 1 <input type="checkbox"/> <i>(If ditch is not permanently flowing treat unit as “intermittently flowing”)</i> • Unit has an unconstricted, or slightly constricted, surface outlet (<i>permanently flowing</i>) points = 0	2
D 3.2	Depth of storage during wet periods. <i>Estimate the height of ponding above the bottom of the outlet. For units with no outlet measure from the surface of permanent water or deepest part (if dry).</i> • Marks of ponding are 3 ft. or more above the surface or bottom of the outlet points = 7 <input type="checkbox"/> • The wetland is a “headwater” wetland..... points = 5 <input type="checkbox"/> • Marks of ponding between 2 ft. to < 3 ft. from surface or bottom of outlet points = 5 <input type="checkbox"/> • Marks are at least 0.5 ft. to < 2 ft. from surface or bottom of outlet points = 3 <input checked="" type="checkbox"/> • Wetland is flat (yes to Q.2 or Q.7 on key) but has small depressions on the surface that trap water . points = 1 <input type="checkbox"/> • Marks of ponding less than 0.5 ft points = 0 <input type="checkbox"/>	3
D 3.3	Contribution of wetland unit to storage in the watershed: <i>Estimate the ratio of the area of upstream basin contributing surface water to the wetland to the area of the wetland unit itself.</i> • The area of the basin is less than 10 times the area of unit..... points = 5 <input type="checkbox"/> • The area of the basin is 10 to 100 times the area of the unit..... points = 3 <input checked="" type="checkbox"/> • The area of the basin is more than 100 times the area of the unit points = 0 <input type="checkbox"/> • Entire unit is in the FLATS class points = 5 <input type="checkbox"/>	3
Total for D 3		<i>Add the points in the boxes above</i> 8

D 4	<p>Does the wetland have the <u>opportunity</u> to reduce flooding and erosion?</p> <p>Answer YES if the unit is in a location in the watershed where the flood storage, or reduction in water velocity, it provides helps protect downstream property and aquatic resources from flooding or excessive and/or erosive flows. Answer NO if the water coming into the wetland is controlled by a structure such as flood gate, tide gate, flap valve, reservoir etc. OR you estimate that more than 90% of the water in the wetland is from groundwater in areas where damaging groundwater flooding does not occur. <i>Note which of the following indicators of opportunity apply.</i></p> <p><input type="checkbox"/> Wetland is in a headwater of a river or stream that has flooding problems.</p> <p><input checked="" type="checkbox"/> Wetland drains to a river or stream that has flooding problems</p> <p><input type="checkbox"/> Wetland has no outlet and impounds surface runoff water that might otherwise flow into a river or stream that has flooding problems</p> <p><input type="checkbox"/> Other _____</p> <p><input checked="" type="checkbox"/> YES multiplier is 2 <input type="checkbox"/> NO multiplier is 1</p>	<p>(see p. 49)</p> <p>Multiplier</p> <p>2</p>
<p>◆ TOTAL – Hydrologic Functions Multiply the score from D3 by D4; then <i>add score to table on p. 1</i></p>		<p><u>16</u></p>

Comments: _____

<i>These questions apply to wetlands of all HGM classes.</i>		Points (only 1 score per box)																
HABITAT FUNCTIONS – Indicators that wetland functions to provide important habitat.																		
H 1	Does the wetland have the potential to provide habitat for many species?																	
H 1.1	<p>Vegetation structure (see P. 72): Check the types of vegetation classes present (as defined by Cowardin) – Size threshold for each class is 1/4 acre or more than 10% of the area if unit is smaller than 2.5 acres.</p> <p><input type="checkbox"/> Aquatic Bed <input type="checkbox"/> Emergent plants <input checked="" type="checkbox"/> Scrub/shrub (areas where shrubs have > 30% cover) <input checked="" type="checkbox"/> Forested (areas where trees have > 30% cover)</p> <p>If the unit has a forested class check if: <input type="checkbox"/> The forested class has 3 out of 5 strata (canopy, sub-canopy, shrubs, herbaceous, moss/ground-cover) that each cover 20% within the forested polygon.</p> <p>Add the number of vegetation types that qualify. If you have:</p> <table border="0"> <tr> <td>4 structures or more..... points = 4</td> <td><input type="checkbox"/></td> <td>Map of Cowardin vegetation classes</td> <td></td> </tr> <tr> <td>3 structures..... points = 2</td> <td><input type="checkbox"/></td> <td></td> <td></td> </tr> <tr> <td>2 structures..... points = 1</td> <td><input checked="" type="checkbox"/></td> <td></td> <td></td> </tr> <tr> <td>1 structure..... points = 0</td> <td><input type="checkbox"/></td> <td></td> <td></td> </tr> </table>	4 structures or more..... points = 4	<input type="checkbox"/>	Map of Cowardin vegetation classes		3 structures..... points = 2	<input type="checkbox"/>			2 structures..... points = 1	<input checked="" type="checkbox"/>			1 structure..... points = 0	<input type="checkbox"/>			<p>Figure <input type="checkbox"/></p> <p>1</p>
4 structures or more..... points = 4	<input type="checkbox"/>	Map of Cowardin vegetation classes																
3 structures..... points = 2	<input type="checkbox"/>																	
2 structures..... points = 1	<input checked="" type="checkbox"/>																	
1 structure..... points = 0	<input type="checkbox"/>																	
H 1.2	<p>Hydroperiods (see p.73): Check the types of water regimes (hydroperiods) present within the wetland. The water regime has to cover more than 10% of the wetland or 1/4 acre to count (see text for descriptions of hydroperiods).</p> <p><input type="checkbox"/> Permanently flooded or inundated <input checked="" type="checkbox"/> Seasonally flooded or inundated <input checked="" type="checkbox"/> Occasionally flooded or inundated <input checked="" type="checkbox"/> Saturated only <input type="checkbox"/> Permanently flowing stream or river in, or adjacent to, the wetland <input type="checkbox"/> Seasonally flowing stream in, or adjacent to, the wetland</p> <p><input type="checkbox"/> Lake-fringe wetland..... = 2 points <input type="checkbox"/> Freshwater tidal wetland..... = 2 points</p> <table border="0"> <tr> <td>4 or more types present</td> <td>points = 3</td> <td><input type="checkbox"/></td> </tr> <tr> <td>3 or more types present</td> <td>points = 2</td> <td><input type="checkbox"/></td> </tr> <tr> <td>2 types present</td> <td>points = 1</td> <td><input checked="" type="checkbox"/></td> </tr> <tr> <td>1 type present</td> <td>points = 0</td> <td><input type="checkbox"/></td> </tr> </table> <p>Map of hydroperiods</p>	4 or more types present	points = 3	<input type="checkbox"/>	3 or more types present	points = 2	<input type="checkbox"/>	2 types present	points = 1	<input checked="" type="checkbox"/>	1 type present	points = 0	<input type="checkbox"/>	<p>Figure <input type="checkbox"/></p> <p>1</p>				
4 or more types present	points = 3	<input type="checkbox"/>																
3 or more types present	points = 2	<input type="checkbox"/>																
2 types present	points = 1	<input checked="" type="checkbox"/>																
1 type present	points = 0	<input type="checkbox"/>																
H 1.3	<p>Richness of Plant Species (see p. 75): Count the number of plant species in the wetland that cover at least 10 ft² (different patches of the same species can be combined to meet the size threshold) You do not have to name the species. Do not include Eurasian Milfoil, reed canarygrass, purple loosestrife, Canadian Thistle.</p> <p>If you counted:</p> <table border="0"> <tr> <td>> 19 species..... points = 2</td> <td><input type="checkbox"/></td> </tr> <tr> <td>5 – 19 species..... points = 1</td> <td><input checked="" type="checkbox"/></td> </tr> <tr> <td>< 5 species..... points = 0</td> <td><input type="checkbox"/></td> </tr> </table> <p>List species below if you want to:</p> <hr/>	> 19 species..... points = 2	<input type="checkbox"/>	5 – 19 species..... points = 1	<input checked="" type="checkbox"/>	< 5 species..... points = 0	<input type="checkbox"/>	<p>1</p>										
> 19 species..... points = 2	<input type="checkbox"/>																	
5 – 19 species..... points = 1	<input checked="" type="checkbox"/>																	
< 5 species..... points = 0	<input type="checkbox"/>																	
H 1.4	<p>Interspersion of Habitats (see p. 76): Decided from the diagrams below whether interspersion between Cowardin vegetation (described in H1.1), or the classes and unvegetated areas (can include open water or mudflats) is high, medium, low, or none.</p> <p>None = 0 points Low = 1 point Moderate = 2 points</p> <p>High = 3 points [riparian braided channels]</p> <p>Note: If you have 4 or more classes or 3 vegetation classes and open water, the rating is always “high”. Use map of Cowardin classes.</p>	<p>Figure <input type="checkbox"/></p> <p>2</p>																
H 1.5	<p>Special Habitat Features (see p. 77): Check the habitat features that are present in the wetland. The number of checks is the number of points you put into the next column.</p> <p><input checked="" type="checkbox"/> Large, downed, woody debris within the wetland (> 4 in. diameter and 6 ft. long) <input type="checkbox"/> Standing snags (diameter at the bottom > 4 inches) in the wetland <input type="checkbox"/> Undercut banks are present for at least 6.6 ft. (2m) and/or overhanging vegetation extends at least 3.3 ft. (1m) over a stream (or ditch) in, or contiguous with the unit, for at least 33 ft. (10m) <input type="checkbox"/> Stable steep banks of fine material that might be used by beaver or muskrat for denning (> 30 degree slope) OR signs of recent beaver activity are present (cut shrubs or trees that have not yet turned grey/brown) <input type="checkbox"/> At least 1/4 acre of thin-stemmed persistent vegetation or woody branches are present in areas that are permanently or seasonally inundated (structures for egg-laying by amphibians) <input type="checkbox"/> Invasive plants cover less than 25% of the wetland area in each stratum of plants</p> <p>NOTE: The 20% stated in early printings of the manual on page 78 is an error.</p>	<p>1</p>																
H 1 TOTAL Score – potential for providing habitat		<p>Add the points in the column above</p> <p>6</p>																

H 2	Does the wetland have the <u>opportunity</u> to provide habitat for many species?	(only 1 score per box)
	<p>H 2.1 <u>Buffers</u> (see P. 80): Choose the description that best represents condition of buffer of wetland unit. The highest scoring criterion that applies to the wetland is to be used in the rating. See text for definition of "undisturbed".</p> <p><input type="checkbox"/> 100m (330 ft) of relatively undisturbed vegetated areas, rocky areas, or open water > 95% of circumference. No structures are within the undisturbed part of buffer (relatively undisturbed also means no grazing, no landscaping, no daily human use)..... points = 5</p> <p><input type="checkbox"/> 100m (330 ft) of relatively undisturbed vegetated areas, rocky areas, or open water > 50% circumference points = 4</p> <p><input type="checkbox"/> 50m (170 ft) of relatively undisturbed vegetated areas, rocky areas, or open water > 95% circumference points = 4</p> <p><input type="checkbox"/> 100m (330 ft) of relatively undisturbed vegetated areas, rocky areas, or open water > 25% circumference points = 3</p> <p><input type="checkbox"/> 50m (170 ft) of relatively undisturbed vegetated areas, rocky areas, or open water for > 50% circumference points = 3</p> <p>If buffer does not meet any of the criteria above:</p> <p><input type="checkbox"/> No paved areas (except paved trails) or buildings within 25m (80 ft) of wetland > 95% circumference. Light to moderate grazing or lawns are OK points = 2</p> <p><input type="checkbox"/> No paved areas of buildings within 50m of wetland for > 50% circumference. Light to moderate grazing or lawns are OK points = 2</p> <p><input type="checkbox"/> Heavy grazing in buffer points = 1</p> <p><input type="checkbox"/> Vegetated buffers are < 2m wide (6.6 ft) for more than 95% circumference (e.g. tilled fields, paving, basalt bedrock extend to edge of wetland) points = 0</p> <p><input checked="" type="checkbox"/> Buffer does not meet any of the criteria above points = 1</p> <p style="text-align: right;">Arial photo showing buffers</p>	<p>Figure <input type="checkbox"/></p> <p style="text-align: right;">1</p>
	<p>H 2.2 <u>Corridors and Connections</u> (see p. 81)</p> <p>H 2.2.1 Is the wetland part of a relatively undisturbed and unbroken vegetated corridor (either riparian or upland) that is at least 150 ft. wide, has at least a 30% cover of shrubs, forest or native undisturbed prairie, that connects to estuaries, other wetlands or undisturbed uplands that are at least 250 acres in size? (<i>Dams in riparian corridors, heavily used gravel roads, paved roads, are considered breaks in the corridor.</i>)</p> <p style="padding-left: 40px;"><input type="checkbox"/> YES = 4 points (go to H 2.3) <input checked="" type="checkbox"/> NO = go to H 2.2.2</p> <p>H. 2.2.2 Is the wetland part of a relatively undisturbed and unbroken vegetated corridor (either riparian or upland) that is at least 50 ft. wide, has at least 30% cover of shrubs or forest, and connects to estuaries, other wetlands or undisturbed uplands that are at least 25 acres in size? OR a Lake-fringe wetland, if it does not have an undisturbed corridor as in the question above?</p> <p style="padding-left: 40px;"><input type="checkbox"/> YES = 2 points (go to H 2.3) <input checked="" type="checkbox"/> NO = go to H 2.2.3</p> <p>H. 2.2.3 Is the wetland:</p> <ul style="list-style-type: none"> • Within 5 mi (8km) of a brackish or salt water estuary OR • Within 3 miles of a large field or pasture (> 40 acres) OR • Within 1 mile of a lake greater than 20 acres? <p style="text-align: right; padding-right: 40px;"><input type="checkbox"/> YES = 1 point <input checked="" type="checkbox"/> NO = 0 points</p>	<p style="text-align: right;">0</p>

Comments: _____

	<p>H 2.3 <u>Near or adjacent to other priority habitats listed by WDFW</u> (see p. 82): <i>(see new and complete descriptions of WDFW priority habitats, and the counties in which they can be found, in the PHS report http://wdfw.wa.gov/hab/phslist.htm)</i> Which of the following priority habitats are within 330 ft. (100m) of the wetland unit? NOTE: <i>the connections do not have to be relatively undisturbed.</i></p> <p><input type="checkbox"/> Aspen Stands: Pure or mixed stands of aspen greater than 0.4 ha (1 acre).</p> <p><input type="checkbox"/> Biodiversity Areas and Corridors: Areas of habitat that are relatively important to various species of native fish and wildlife <i>(full descriptions in WDFW PHS report p. 152).</i></p> <p><input type="checkbox"/> Herbaceous Balds: Variable size patches of grass and forbs on shallow soils over bedrock.</p> <p><input type="checkbox"/> Old-growth/Mature forests: (Old-growth west of Cascade crest) Stands of at least 2 tree species, forming a multi-layered canopy with occasional small openings; with at least 20 trees/ha (8 trees/acre) > 81 cm (32 in) dbh or > 200 years of age. (Mature forests) Stands with average diameters exceeding 53 cm (21 in) dbh; crown cover may be less than 100%; decay, decadence, numbers of snags, and quantity of large downed material is generally less than that found in old-growth; 80 - 200 years old west of the Cascade crest.</p> <p><input type="checkbox"/> Oregon white Oak: Woodlands Stands of pure oak or oak/conifer associations where canopy coverage of the oak component is important <i>(full descriptions in WDFW PHS report p. 158).</i></p> <p><input type="checkbox"/> Riparian: The area adjacent to aquatic systems with flowing water that contains elements of both aquatic and terrestrial ecosystems which mutually influence each other.</p> <p><input type="checkbox"/> Westside Prairies: Herbaceous, non-forested plant communities that can either take the form of a dry prairie or a wet prairie <i>(full descriptions in WDFW PHS report p. 161).</i></p> <p><input type="checkbox"/> Instream: The combination of physical, biological, and chemical processes and conditions that interact to provide functional life history requirements for instream fish and wildlife resources.</p> <p><input type="checkbox"/> Nearshore: Relatively undisturbed nearshore habitats. These include Coastal Nearshore, Open Coast Nearshore, and Puget Sound Nearshore. <i>(full descriptions of habitats and the definition of relatively undisturbed are in WDFW report: pp. 167-169 and glossary in Appendix A).</i></p> <p><input type="checkbox"/> Caves: A naturally occurring cavity, recess, void, or system of interconnected passages under the earth in soils, rock, ice, or other geological formations and is large enough to contain a human.</p> <p><input type="checkbox"/> Cliffs: Greater than 7.6 m (25 ft) high and occurring below 5000 ft.</p> <p><input type="checkbox"/> Talus: Homogenous areas of rock rubble ranging in average size 0.15 - 2.0 m (0.5 - 6.5 ft), composed of basalt, andesite, and/or sedimentary rock, including riprap slides and mine tailings. May be associated with cliffs.</p> <p><input type="checkbox"/> Snags and Logs: Trees are considered snags if they are dead or dying and exhibit sufficient decay characteristics to enable cavity excavation/use by wildlife. Priority snags have a diameter at breast height of > 51 cm (20 in) in western Washington and are > 2 m (6.5 ft) in height. Priority logs are > 30 cm (12 in) in diameter at the largest end, and > 6 m (20 ft) long.</p> <p style="text-align: right;">If wetland has 3 or more priority habitats = 4 points If wetland has 2 priority habitats = 3 points If wetland has 1 priority habitat = 1 point No habitats = 0 points</p> <p>Note: All vegetated wetlands are by definition a priority habitat but are not included in this list. Nearby wetlands are addressed in question H 2.4)</p>	0
	<p>H 2.4 <u>Wetland Landscape:</u> <i>Choose the one description of the landscape around the wetland that best fits (see p. 84)</i></p> <ul style="list-style-type: none"> • There are at least 3 other wetlands within 1/2 mile, and the connections between them are relatively undisturbed (light grazing between wetlands OK, as is lake shore with some boating, but connections should NOT be bisected by paved roads, fill, fields, or other development.... points = 5 <input type="checkbox"/> • The wetland is Lake-fringe on a lake with little disturbance and there are 3 other lake-fringe wetlands within 1/2 mile points = 5 <input type="checkbox"/> • There are at least 3 other wetlands within 1/2 mile, BUT the connections between them are disturbed. points = 3 <input checked="" type="checkbox"/> • The wetland fringe on a lake with disturbance and there are 3 other lake-fringe wetlands within 1/2 mile points = 3 <input type="checkbox"/> • There is at least 1 wetland within 1/2 mile points = 2 <input type="checkbox"/> • There are no wetlands within 1/2 mile..... points = 0 <input type="checkbox"/> 	3
	<p>H 2 TOTAL Score – opportunity for providing habitat <i>Add the scores from H2.1, H2.2, H2.3, H2.4</i></p>	4
	<p><i>TOTAL for H 1 from page 8</i></p>	6
◆	<p>Total Score for Habitat Functions <i>Add the points for H 1 and H 2; then record the result on p. 1</i></p>	10

Comments: _____

CATEGORIZATION BASED ON SPECIAL CHARACTERISTICS

Please determine if the wetland meets the attributes described below and circle the appropriate answers and Category.

Wetland Type – Check off any criteria that apply to the wetland. Circle the Category when the appropriate criteria are met.	
SC1	<p>Estuarine wetlands? (see p.86)</p> <p>Does the wetland unit meet the following criteria for Estuarine wetlands?</p> <p><input type="checkbox"/> The dominant water regime is tidal, <input type="checkbox"/> Vegetated, and <input type="checkbox"/> With a salinity greater than 0.5 ppt.</p> <p style="text-align: center;"><input type="checkbox"/> YES = Go to SC 1.1 <input checked="" type="checkbox"/> NO</p>
	<p>SC 1.1 Is the wetland unit within a National Wildlife Refuge, National Park, National Estuary Reserve, Natural Area Preserve, State Park or Educational, Environmental, or Scientific Reserve designated under WAC 332-30-151? <input type="checkbox"/> YES = Category I <input type="checkbox"/> NO = go to SC 1.2</p>
	<p>SC 1.2 Is the wetland at least 1 acre in size and meets at least two of the following conditions?</p> <p style="text-align: center;"><input type="checkbox"/> YES = Category I <input type="checkbox"/> NO = Category II</p> <p><input type="checkbox"/> The wetland is relatively undisturbed (has no diking, ditching, filling, cultivation, grazing, and has less than 10% cover of non-native plant species. If the non-native <i>Spartina</i> spp. are only species that cover more than 10% of the wetland, then the wetland should be given a dual rating (I/II). The area of <i>Spartina</i> would be rated a Category II while the relatively undisturbed upper marsh with native species would be a Category I. Do not, however, exclude the area of <i>Spartina</i> in determining the size threshold of 1 acre.</p> <p><input type="checkbox"/> At least 3/4 of the landward edge of the wetland has a 100 ft. buffer of shrub, forest, or un-grazed or un-mowed grassland</p> <p><input type="checkbox"/> The wetland has at least 2 of the following features: tidal channels, depressions with open water, or contiguous freshwater wetlands.</p>
SC2	<p>Natural Heritage Wetlands (see p. 87)</p> <p>Natural Heritage wetlands have been identified by the Washington Natural Heritage Program/DNR as either high quality undisturbed wetlands or wetlands that support state Threatened, Endangered, or Sensitive plant species.</p> <p>SC 2.1 Is the wetland being rated in a Section/Township/Range that contains a natural heritage wetland? (This question is used to screen out most sites before you need to contact WNHP/DNR.)</p> <p style="text-align: center;"><input type="checkbox"/> S/T/R information from Appendix D <input type="checkbox"/> or accessed from WNHP/DNR web site</p> <p style="text-align: center;"><input type="checkbox"/> YES Contact WNHP/DNR (see p. 79) and go to SC 2.2 <input checked="" type="checkbox"/> NO</p> <p>SC 2.2 Has DNR identified the wetland as a high quality undisturbed wetland or as a site with state threatened or endangered plant species?</p> <p style="text-align: center;"><input type="checkbox"/> YES = Category 1 <input checked="" type="checkbox"/> NO not a Heritage Wetland</p>
SC3	<p>Bogs (see p. 87)</p> <p>Does the wetland (or any part of the unit) meet both the criteria for soils and vegetation in bogs? Use the key below to identify if the wetland is a bog. If you answer yes you will still need to rate the wetland based on its function.</p> <p>1. Does the unit have organic soil horizons (i.e. layers of organic soil), either peats or mucks, that compose 16 inches or more of the first 32 inches of soil profile? (See Appendix B for a field key to identify organic soils)? <input type="checkbox"/> YES = go to question 3 <input checked="" type="checkbox"/> NO = go to question 2</p> <p>2. Does the wetland have organic soils, either peats or mucks that are less than 16 inches deep over bedrock, or an impermeable hardpan such as clay or volcanic ash, or that are floating on a lake or pond? <input type="checkbox"/> YES = go to question 3 <input checked="" type="checkbox"/> NO = is not a bog for purpose of rating</p> <p>3. Does the unit have more than 70% cover of mosses at ground level, AND other plants, if present, consist of the “bog” species listed in Table 3 as a significant component of the vegetation (more than 30% of the total shrub and herbaceous cover consists of species in Table 3)?</p> <p style="text-align: center;"><input type="checkbox"/> YES = Is a bog for purpose of rating <input checked="" type="checkbox"/> NO = go to question 4</p> <p>NOTE: If you are uncertain about the extent of mosses in the understory you may substitute that criterion by measuring the pH of the water that seeps into a hole dug at least 16” deep. If the pH is less than 5.0 and the “bog” plant species in Table 3 are present, the wetland is a bog.</p> <p>4. Is the unit forested (> 30% cover) with sitka spruce, subalpine fir, western red cedar, western hemlock, lodgepole pine, quaking aspen, Englemann’s spruce, or western white pine. WITH any of the species (or combination of species) on the bog species plant list in Table 3 as a significant component of the ground cover (> 30% coverage of the total shrub/herbaceous cover)?</p> <p style="text-align: center;"><input type="checkbox"/> YES = Category I <input checked="" type="checkbox"/> NO = Is not a bog for purpose of rating</p>
	<p>Cat. I <input type="checkbox"/></p>

SC4	<p>Forested Wetlands (see p. 90)</p> <p>Does the wetland have at least 1 acre of forest that meet one of these criteria for the Department of Fish and Wildlife’s forests as priority habitats? <i>If you answer yes you will still need to rate the wetland based on its function.</i></p> <p><input type="checkbox"/> Old-growth forests: (west of Cascade Crest) Stands of at least two three species forming a multi-layered canopy with occasional small openings; with at least 8 trees/acre (20 trees/hectare) that are at least 200 years of age OR have a diameter at breast height (dbh) of 32 inches (81 cm or more). NOTE: The criterion for dbh is based on measurements for upland forests. Two-hundred year old trees in wetlands will often have a smaller dbh because their growth rates are often slower. The DFW criterion is and “OR” so old-growth forests do not necessarily have to have trees of this diameter.</p> <p><input type="checkbox"/> Mature forests: (west of the Cascade Crest) Stands where the largest trees are 80 – 200 years old OR have an average diameters (dbh) exceeding 21 inches (53 cm); crown cover may be less than 100%; decay, decadence, numbers of snags, and quantity of large downed material is generally less than that found in old-growth.</p> <p><input type="checkbox"/> YES = Category I <input checked="" type="checkbox"/> NO = not a forested wetland with special characteristics</p>	<p>Cat. I <input type="checkbox"/></p>
SC5	<p>Wetlands in Coastal Lagoons (see p. 91)</p> <p>Does the wetland meet all of the following criteria of a wetland in a coastal lagoon?</p> <p><input type="checkbox"/> The wetland lies in a depression adjacent to marine waters that is wholly or partially separated from marine waters by sandbanks, gravel banks, shingle, or, less frequently, rocks.</p> <p><input type="checkbox"/> The lagoon in which the wetland is located contains surface water that is saline or brackish (> 0.5 ppt) during most of the year in at least a portion of the lagoon (<i>needs to be measured near the bottom.</i>)</p> <p><input type="checkbox"/> YES = Go to SC 5.1 <input checked="" type="checkbox"/> NO not a wetland in a coastal lagoon</p> <p>SC 5.1 Does the wetland meet all of the following three conditions?</p> <p><input type="checkbox"/> The wetland is relatively undisturbed (has no diking, ditching, filling, cultivation, grazing) and has less than 20% cover of invasive plant species (see list of invasive species on p. 74).</p> <p><input type="checkbox"/> At least 3/4 of the landward edge of the wetland has a 100 ft. buffer of shrub, forest, or un-grazed or un-mowed grassland.</p> <p><input type="checkbox"/> The wetland is larger than 1/10 acre (4350 square ft.)</p> <p><input type="checkbox"/> YES = Category I <input type="checkbox"/> NO = Category II</p>	<p style="background-color: #cccccc;"> </p> <p>Cat. I <input type="checkbox"/></p> <p>Cat. II <input type="checkbox"/></p>
SC6	<p>Interdunal Wetlands (see p. 93)</p> <p>Is the wetland west of the 1889 line (also called the Western Boundary of Upland Ownership or WBUO)?</p> <p><input type="checkbox"/> YES = Go to SC 6.1 <input checked="" type="checkbox"/> NO not an interdunal wetland for rating</p> <p><i>If you answer yes you will still need to rate the wetland based on its functions.</i></p> <p>In practical terms that means the following geographic areas:</p> <ul style="list-style-type: none"> • Long Beach Peninsula -- lands west of SR 103 • Grayland-Westport -- lands west of SR 105 • Ocean Shores-Copalis – lands west of SR 115 and SR 109 <p>SC 6.1 Is the wetland one acre or larger, or is it in a mosaic of wetlands that is one acre or larger?</p> <p><input type="checkbox"/> YES = Category II <input type="checkbox"/> NO = go to SC 6.2</p> <p>SC 6.2 Is the wetland between 0.1 and 1 acre, or is it in a mosaic of wetlands that is between 0.1 and 1 acre?</p> <p><input type="checkbox"/> YES = Category III</p>	<p>Cat. II <input type="checkbox"/></p> <p>Cat. III <input type="checkbox"/></p>
◆	<p>Category of wetland based on Special Characteristics</p> <p><i>Choose the “highest” rating if wetland falls into several categories, and record on p. 1.</i></p> <p>If you answered NO for all types enter “Not Applicable” on p. 1</p>	<p>NA</p>

Comments:

WETLAND RATING FORM – WESTERN WASHINGTON
 Version 2 – Updated July 2006 to increase accuracy and reproducibility among users
 Updated Oct. 2008 with the new WDFW definitions for priority habitats

Name of wetland (if known): BNSF Northwest

Date of site visit: April 23, 2013

Rated by: C. Douglas & J. Pursley Trained by Ecology? Yes No

Date of training: May 2007

SEC: 29 TOWNSHP: 24N RNGE: 5E

Is S/T/R in Appendix D? Yes No

Map of wetland unit: Figure _____ Estimated size _____

SUMMARY OF RATING

Category based on FUNCTIONS provided by wetland: I II III IV

Category I =	Score > 70
Category II =	Score 51 - 69
Category III =	Score 30 – 50
Category IV =	Score < 30

Score for Water Quality Functions

8

Score for Hydrologic Functions

6

Score for Habitat Functions

10

TOTAL Score for Functions

24

Category based on SPECIAL CHARACTERISTICS of Wetland I II Does not apply

Final Category (choose the “highest” category from above”)

IV

Summary of basic information about the wetland unit.

Wetland Unit has Special Characteristics		Wetland HGM Class used for Rating	
Estuarine	<input type="checkbox"/>	Depressional	<input checked="" type="checkbox"/>
Natural Heritage Wetland	<input type="checkbox"/>	Riverine	<input type="checkbox"/>
Bog	<input type="checkbox"/>	Lake-fringe	<input type="checkbox"/>
Mature Forest	<input type="checkbox"/>	Slope	<input checked="" type="checkbox"/>
Old Growth Forest	<input type="checkbox"/>	Flats	<input type="checkbox"/>
Coastal Lagoon	<input type="checkbox"/>	Freshwater Tidal	<input type="checkbox"/>
Interdunal	<input type="checkbox"/>		<input type="checkbox"/>
None of the above	<input checked="" type="checkbox"/>	Check if unit has multiple HGM classes present	<input checked="" type="checkbox"/>

Does the wetland being rated meet any of the criteria below? If you answer YES to any of the questions below you will need to protect the wetland according to the regulations regarding the special characteristics found in the wetland.

Check List for Wetlands that Need Additional Protection (in addition to the protection recommended for its category)	YES	NO
SP1. <i>Has the wetland unit been documented as a habitat for any Federally listed Threatened or Endangered animal or plant species (T/E species)?</i> For the purposes of this rating system, “documented” means the wetland is on the appropriate state or federal database.	<input type="checkbox"/>	<input checked="" type="checkbox"/>
SP2. <i>Has the wetland unit been documented as habitat for any State listed Threatened or Endangered animal species?</i> For the purposes of this rating system, “documented” means the wetland is on the appropriate state database. Note: Wetlands with State listed plant species are categorized as Category 1 Natural Heritage Wetlands (see p. 19 of data form).	<input type="checkbox"/>	<input checked="" type="checkbox"/>
SP3. <i>Does the wetland unit contain individuals of Priority species listed by the WDFW for the state?</i>	<input type="checkbox"/>	<input checked="" type="checkbox"/>
SP4. <i>Does the wetland unit have a local significance in addition to its functions?</i> For example, the wetland has been identified in the Shoreline Master Program, the Critical Areas Ordinance, or in a local management plan as having special significance.	<input type="checkbox"/>	<input checked="" type="checkbox"/>

To complete the next part of the data sheet you will need to determine the Hydrogeomorphic Class of the wetland being rated.

The hydrogeomorphic classification groups wetlands in to those that function in similar ways. This simplifies the questions needed to answer how well the wetland functions. The Hydrogeomorphic Class of a wetland can be determined using the key below. See p. 24 for more detailed instructions on classifying wetlands.

Classification of Vegetated Wetlands for Western Washington

If the hydrologic criteria listed in each question do not apply to the entire unit being rated, you probably have a unit with multiple HGM classes. In this case, identify which hydrologic criteria in questions 1-7 apply, and go to Question 8.

1. Are the water levels in the entire unit usually controlled by tides (i.e. except during floods)?
 NO – go to 2 YES – the wetland class is **Tidal Fringe**
 If yes, is the salinity of the water during periods of annual low flow below 0.5 ppt (parts per thousand)?
 YES – **Freshwater Tidal Fringe** NO – **Saltwater Tidal Fringe (Estuarine)**
*If your wetland can be classified as a Freshwater Tidal Fringe use the forms for **Riverine** wetlands. If it is a Saltwater Tidal Fringe it is rated as an **Estuarine** wetland. Wetlands that were call estuarine in the first and second editions of the rating system are called Salt Water Tidal Fringe in the Hydrogeomorphic Classification. Estuarine wetlands were categorized separately in the earlier editions, and this separation is being kept in this revision. To maintain consistency between editions, the term “Estuarine” wetland is kept. Please note, however, that the characteristics that define Category I and II estuarine wetlands have changed (see p. _____).*
-
2. The entire wetland unit is flat and precipitation is only source (>90%) of water to it. Groundwater and surface water runoff are NOT sources of water to the unit.
 NO – go to 3 YES – The wetland class is **Flats**
 If your wetland can be classified as a “Flats” wetland, use the form for **Depressional** wetlands.
-
3. Does the entire wetland meet both of the following criteria?
 The vegetated part of the wetland is on the shores of a body of permanent open water (without any vegetation on the surface) where at least 20 acres (8ha) in size;
 At least 30% of the open water area is deeper than 6.6 (2 m)?
 NO – go to 4 YES – The wetland class is **Lake-fringe (Lacustrine Fringe)**
-
4. Does the entire wetland meet all of the following criteria?
 The wetland is on a slope (*slope can be very gradual*).
 The water flows through the wetland in one direction (unidirectional) and usually comes from seeps. It may flow subsurface, as sheetflow, or in a swale without distinct banks.
 The water leaves the wetland **without being impounded?**
 NOTE: *Surface water does not pond in these types of wetlands except occasionally in very small and shallow depressions or behind hummocks (depressions are usually <3 ft diameter and less than 1 foot deep).*
 NO – go to 5 YES – The wetland class is **Slope**
-
5. Does the entire wetland meet all of the following criteria?
 The unit is in a valley or stream channel where it gets inundated by overbank flooding from that stream or river.
 The overbank flooding occurs at least once every two years.
 NOTE: *The riverine unit can contain depressions that are filled with water when the river is not flooding..*
 NO – go to 6 YES – The wetland class is **Riverine**
-
6. Is the entire wetland unit in a topographic depression in which water ponds, or is saturated to the surface, at some time of the year. This means that any outlet, if present is higher than the interior of the wetland.
 NO – go to 7 YES – The wetland class is **Depressional**
-
7. Is the entire wetland located in a very flat area with no obvious depression and no overbank flooding. The unit does not pond surface water more than a few inches. The unit seems to be maintained by high groundwater in the area. The wetland may be ditched, but has no obvious natural outlet.
 No – go to 8 YES – The wetland class is **Depressional**
-
8. Your wetland unit seems to be difficult to classify and probably contains several different HGM classes. For example, seeps at the base of a slope may grade into a riverine floodplain, or a small stream within a depressional wetland has a zone of flooding along its sides. GO BACK AND IDENTIFY WHICH OF THE HYDROLOGIC REGIMES DESCRIBED IN QUESTIONS 1-7 APPLY TO DIFFERENT AREAS IN THE UNIT (make a rough sketch to help you decide). Use the following table to identify the appropriate class to use for the rating system if you have several HGM classes present within your wetland. NOTE: Use this table only if the class that is recommended in the second column represents 10% or more of the total area of the wetland unit being rated. If the area of the class listed in column 2 is less than 10% of the unit, classify the wetland using the class that represents more than 90% of the total area.

HGM Classes within the wetland unit being rated	HGM Class to Use in Rating
Slope + Riverine	Riverine
Slope + Depressional	Depressional
Slope + Lake-fringe	Lake-fringe
Depressional + Riverine along stream within boundary	Depressional
Depressional + Lake-fringe	Depressional
Salt Water Tidal Fringe and any other class of freshwater wetland	Treat as ESTUARINE under wetlands with special characteristics

If you are unable still to determine which of the above criteria apply to your wetland, or you have more than 2 HGM classes within a wetland boundary, classify the wetland as **Depressional** for the rating.

D Depressional and Flat Wetlands		Points
WATER QUALITY FUNCTIONS – Indicators that wetland functions to improve water quality.		(only 1 score per box) (see p.38)
D 1	Does the wetland have the potential to improve water quality?	
D 1.1	Characteristics of surface water flows out of the wetland: • Unit is a depression with no surface water leaving it (no outlet) points = 3 <input type="checkbox"/> • Unit has an intermittently flowing, OR highly constricted, permanently flowing outlet ... points = 2 <input type="checkbox"/> • Unit has an unconstricted, or slightly constricted, surface outlet (<i>permanently flowing</i>) .. points = 1 <input checked="" type="checkbox"/> • Unit is a “flat” depression (Q.7 on key), or in the Flats class, with permanent surface outflow and no obvious natural outlet and/or outlet is a man-made ditch..... points = 1 <input type="checkbox"/> <i>(If ditch is not permanently flowing treat unit as “intermittently flowing”)</i> Provide photo or drawing	Figure <input type="checkbox"/> 1
D 1.2	The soil 2 inches below the surface (or duff layer) is clay or organic (<i>use NRCS definitions</i>) YES points = 4 NO points = 0	0
D 1.3	Characteristics of persistent vegetation (emergent, shrub, and/or forest Cowardin class): • Wetland has persistent, ungrazed vegetation > = 95% of area points = 5 <input type="checkbox"/> • Wetland has persistent, ungrazed vegetation > = 1/2 of area points = 3 <input checked="" type="checkbox"/> • Wetland has persistent, ungrazed vegetation > = 1/10 of area points = 1 <input type="checkbox"/> • Wetland has persistent, ungrazed vegetation < 1/10 of area points = 0 <input type="checkbox"/> Map of Cowardin vegetation classes	Figure <input type="checkbox"/> 3
D 1.4	Characteristics of seasonal ponding or inundation: <i>This is the area of the wetland that is ponded for at least 2 months, but dries out sometime during the year. Do not count the area that is permanently ponded. Estimate area as the average condition 5 out of 10 years.</i> • Area seasonally ponded is > 1/2 total area of wetland points = 4 <input type="checkbox"/> • Area seasonally ponded is > 1/4 total area of wetland points = 2 <input type="checkbox"/> • Area seasonally ponded is < 1/4 total area of wetland points = 0 <input checked="" type="checkbox"/> Map of Hydroperiods	Figure <input type="checkbox"/> 0
Total for D 1		<i>Add the points in the boxes above</i> 4
D 2	Does the wetland have the opportunity to improve water quality?	(see p. 44)
Answer YES if you know or believe there are pollutants in groundwater or surface water coming into the wetland that would otherwise reduce water quality in streams, lakes or groundwater downgradient from the wetland? <i>Note which of the following conditions provide the sources of pollutants. A unit may have pollutants coming from several sources, but any single source would qualify as opportunity.</i> <input type="checkbox"/> Grazing in the wetland or within 150 ft <input checked="" type="checkbox"/> Untreated stormwater discharges to wetland <input type="checkbox"/> Tilled fields or orchards within 150 ft. of wetland <input checked="" type="checkbox"/> A stream or culvert discharges into wetland that drains developed areas, residential areas, farmed fields, roads, or clear-cut logging <input checked="" type="checkbox"/> Residential, urban areas, golf courses are within 150 ft. of wetland <input type="checkbox"/> Wetland is fed by groundwater high in phosphorus or nitrogen <input type="checkbox"/> Other _____		Multiplier 2
<input checked="" type="checkbox"/> YES multiplier is 2 <input type="checkbox"/> NO multiplier is 1		
◆ TOTAL – Water Quality Functions		Multiply the score from D1 by D2; then add score to table on p. 1 8
HYDROLOGIC FUNCTIONS – Indicators that wetland unit functions to reduce flooding and stream degradation.		
D 3	Does the wetland have the potential to reduce flooding and erosion?	(see p.46)
D 3.1	Characteristics of surface water flows out of the wetland unit • Unit is a depression with no surface water leaving it (no outlet) points = 4 <input type="checkbox"/> • Unit has an intermittently flowing, OR highly constricted permanently flowing outlet points = 2 <input type="checkbox"/> • Unit is a “flat” depression (Q.7 on key) or in the Flats class, with permanent surface outflow and no obvious natural outlet and/or outlet is a man-made ditch..... points = 1 <input type="checkbox"/> <i>(If ditch is not permanently flowing treat unit as “intermittently flowing”)</i> • Unit has an unconstricted, or slightly constricted, surface outlet (<i>permanently flowing</i>) points = 0	0
D 3.2	Depth of storage during wet periods. <i>Estimate the height of ponding above the bottom of the outlet. For units with no outlet measure from the surface of permanent water or deepest part (if dry).</i> • Marks of ponding are 3 ft. or more above the surface or bottom of the outlet points = 7 <input type="checkbox"/> • The wetland is a “headwater” wetland..... points = 5 <input type="checkbox"/> • Marks of ponding between 2 ft. to < 3 ft. from surface or bottom of outlet points = 5 <input type="checkbox"/> • Marks are at least 0.5 ft. to < 2 ft. from surface or bottom of outlet points = 3 <input type="checkbox"/> • Wetland is flat (yes to Q.2 or Q.7 on key) but has small depressions on the surface that trap water . points = 1 <input type="checkbox"/> • Marks of ponding less than 0.5 ft points = 0 <input checked="" type="checkbox"/>	0
D 3.3	Contribution of wetland unit to storage in the watershed: <i>Estimate the ratio of the area of upstream basin contributing surface water to the wetland to the area of the wetland unit itself.</i> • The area of the basin is less than 10 times the area of unit..... points = 5 <input type="checkbox"/> • The area of the basin is 10 to 100 times the area of the unit..... points = 3 <input checked="" type="checkbox"/> • The area of the basin is more than 100 times the area of the unit points = 0 <input type="checkbox"/> • Entire unit is in the FLATS class points = 5 <input type="checkbox"/>	3
Total for D 3		<i>Add the points in the boxes above</i> 3

D 4	<p>Does the wetland have the <u>opportunity</u> to reduce flooding and erosion?</p> <p>Answer YES if the unit is in a location in the watershed where the flood storage, or reduction in water velocity, it provides helps protect downstream property and aquatic resources from flooding or excessive and/or erosive flows. Answer NO if the water coming into the wetland is controlled by a structure such as flood gate, tide gate, flap valve, reservoir etc. OR you estimate that more than 90% of the water in the wetland is from groundwater in areas where damaging groundwater flooding does not occur. <i>Note which of the following indicators of opportunity apply.</i></p> <p><input type="checkbox"/> Wetland is in a headwater of a river or stream that has flooding problems.</p> <p><input checked="" type="checkbox"/> Wetland drains to a river or stream that has flooding problems</p> <p><input type="checkbox"/> Wetland has no outlet and impounds surface runoff water that might otherwise flow into a river or stream that has flooding problems</p> <p><input type="checkbox"/> Other _____</p> <p><input checked="" type="checkbox"/> YES multiplier is 2 <input type="checkbox"/> NO multiplier is 1</p>	<p>(see p. 49)</p> <p>Multiplier</p> <p>2</p>
◆	<p>TOTAL – Hydrologic Functions Multiply the score from D3 by D4; then <i>add score to table on p. 1</i></p>	<p><u>6</u></p>

Comments: _____

These questions apply to wetlands of all HGM classes.		Points																
HABITAT FUNCTIONS – Indicators that wetland functions to provide important habitat.		(only 1 score per box)																
H 1	Does the wetland have the potential to provide habitat for many species?																	
H 1.1	<p>Vegetation structure (see P. 72): Check the types of vegetation classes present (as defined by Cowardin) – Size threshold for each class is 1/4 acre or more than 10% of the area if unit is smaller than 2.5 acres.</p> <p><input type="checkbox"/> Aquatic Bed <input checked="" type="checkbox"/> Emergent plants <input type="checkbox"/> Scrub/shrub (areas where shrubs have > 30% cover) <input checked="" type="checkbox"/> Forested (areas where trees have > 30% cover)</p> <p>If the unit has a forested class check if: <input type="checkbox"/> The forested class has 3 out of 5 strata (canopy, sub-canopy, shrubs, herbaceous, moss/ground-cover) that each cover 20% within the forested polygon. Add the number of vegetation types that qualify. If you have:</p> <table style="width: 100%; border: none;"> <tr> <td style="text-align: right;">4 structures or more..... points = 4</td> <td style="text-align: right;"><input type="checkbox"/></td> <td style="text-align: right;">Map of Cowardin vegetation classes</td> <td style="text-align: right;">3 structures..... points = 2</td> <td style="text-align: right;"><input type="checkbox"/></td> </tr> <tr> <td style="text-align: right;">2 structures..... points = 1</td> <td style="text-align: right;"><input checked="" type="checkbox"/></td> <td></td> <td style="text-align: right;">1 structure..... points = 0</td> <td style="text-align: right;"><input type="checkbox"/></td> </tr> </table>	4 structures or more..... points = 4	<input type="checkbox"/>	Map of Cowardin vegetation classes	3 structures..... points = 2	<input type="checkbox"/>	2 structures..... points = 1	<input checked="" type="checkbox"/>		1 structure..... points = 0	<input type="checkbox"/>	<p>Figure <input type="checkbox"/></p> <p style="text-align: center;">1</p>						
4 structures or more..... points = 4	<input type="checkbox"/>	Map of Cowardin vegetation classes	3 structures..... points = 2	<input type="checkbox"/>														
2 structures..... points = 1	<input checked="" type="checkbox"/>		1 structure..... points = 0	<input type="checkbox"/>														
H 1.2	<p>Hydroperiods (see p.73): Check the types of water regimes (hydroperiods) present within the wetland. The water regime has to cover more than 10% of the wetland or 1/4 acre to count (see text for descriptions of hydroperiods).</p> <table style="width: 100%; border: none;"> <tr> <td style="text-align: right;"><input type="checkbox"/> Permanently flooded or inundated</td> <td style="text-align: right;">4 or more types present</td> <td style="text-align: right;">points = 3</td> <td style="text-align: right;"><input type="checkbox"/></td> </tr> <tr> <td style="text-align: right;"><input checked="" type="checkbox"/> Seasonally flooded or inundated</td> <td style="text-align: right;">3 or more types present</td> <td style="text-align: right;">points = 2</td> <td style="text-align: right;"><input type="checkbox"/></td> </tr> <tr> <td style="text-align: right;"><input checked="" type="checkbox"/> Occasionally flooded or inundated</td> <td style="text-align: right;">2 types present</td> <td style="text-align: right;">points = 1</td> <td style="text-align: right;"><input checked="" type="checkbox"/></td> </tr> <tr> <td style="text-align: right;"><input checked="" type="checkbox"/> Saturated only</td> <td style="text-align: right;">1 type present</td> <td style="text-align: right;">points = 0</td> <td style="text-align: right;"><input type="checkbox"/></td> </tr> </table> <p><input type="checkbox"/> Permanently flowing stream or river in, or adjacent to, the wetland <input type="checkbox"/> Seasonally flowing stream in, or adjacent to, the wetland <input type="checkbox"/> Lake-fringe wetland..... = 2 points <input type="checkbox"/> Freshwater tidal wetland..... = 2 points</p> <p style="text-align: right;">Map of hydroperiods</p>	<input type="checkbox"/> Permanently flooded or inundated	4 or more types present	points = 3	<input type="checkbox"/>	<input checked="" type="checkbox"/> Seasonally flooded or inundated	3 or more types present	points = 2	<input type="checkbox"/>	<input checked="" type="checkbox"/> Occasionally flooded or inundated	2 types present	points = 1	<input checked="" type="checkbox"/>	<input checked="" type="checkbox"/> Saturated only	1 type present	points = 0	<input type="checkbox"/>	<p>Figure <input type="checkbox"/></p> <p style="text-align: center;">1</p>
<input type="checkbox"/> Permanently flooded or inundated	4 or more types present	points = 3	<input type="checkbox"/>															
<input checked="" type="checkbox"/> Seasonally flooded or inundated	3 or more types present	points = 2	<input type="checkbox"/>															
<input checked="" type="checkbox"/> Occasionally flooded or inundated	2 types present	points = 1	<input checked="" type="checkbox"/>															
<input checked="" type="checkbox"/> Saturated only	1 type present	points = 0	<input type="checkbox"/>															
H 1.3	<p>Richness of Plant Species (see p. 75): Count the number of plant species in the wetland that cover at least 10 ft² (different patches of the same species can be combined to meet the size threshold) You do not have to name the species. Do not include Eurasian Milfoil, reed canarygrass, purple loosestrife, Canadian Thistle. If you counted: > 19 species points = 2 <input type="checkbox"/> 5 – 19 species..... points = 1 <input checked="" type="checkbox"/> < 5 species points = 0 <input type="checkbox"/></p> <p>List species below if you want to:</p>	<p style="text-align: center;">1</p>																
H 1.4	<p>Interspersion of Habitats (see p. 76): Decided from the diagrams below whether interspersion between Cowardin vegetation (described in H1.1), or the classes and unvegetated areas (can include open water or mudflats) is high, medium, low, or none.</p> <div style="text-align: center;"> </div> <p>Note: If you have 4 or more classes or 3 vegetation classes and open water, the rating is always “high”. Use map of Cowardin classes.</p>	<p>Figure <input type="checkbox"/></p> <p style="text-align: center;">2</p>																
H 1.5	<p>Special Habitat Features (see p. 77): Check the habitat features that are present in the wetland. The number of checks is the number of points you put into the next column.</p> <p><input checked="" type="checkbox"/> Large, downed, woody debris within the wetland (> 4 in. diameter and 6 ft. long) <input type="checkbox"/> Standing snags (diameter at the bottom > 4 inches) in the wetland <input type="checkbox"/> Undercut banks are present for at least 6.6 ft. (2m) and/or overhanging vegetation extends at least 3.3 ft. (1m) over a stream (or ditch) in, or contiguous with the unit, for at least 33 ft. (10m) <input type="checkbox"/> Stable steep banks of fine material that might be used by beaver or muskrat for denning (> 30 degree slope) OR signs of recent beaver activity are present (cut shrubs or trees that have not yet turned grey/brown) <input type="checkbox"/> At least 1/4 acre of thin-stemmed persistent vegetation or woody branches are present in areas that are permanently or seasonally inundated (structures for egg-laying by amphibians) <input type="checkbox"/> Invasive plants cover less than 25% of the wetland area in each stratum of plants NOTE: The 20% stated in early printings of the manual on page 78 is an error.</p>	<p style="text-align: center;">1</p>																
H 1 TOTAL Score – potential for providing habitat		6																
Add the points in the column above																		

H 2	Does the wetland have the <u>opportunity</u> to provide habitat for many species?	(only 1 score per box)
	<p>H 2.1 <u>Buffers</u> (see P. 80): Choose the description that best represents condition of buffer of wetland unit. The highest scoring criterion that applies to the wetland is to be used in the rating. See text for definition of "undisturbed".</p> <p><input type="checkbox"/> 100m (330 ft) of relatively undisturbed vegetated areas, rocky areas, or open water > 95% of circumference. No structures are within the undisturbed part of buffer (relatively undisturbed also means no grazing, no landscaping, no daily human use)..... points = 5</p> <p><input type="checkbox"/> 100m (330 ft) of relatively undisturbed vegetated areas, rocky areas, or open water > 50% circumference points = 4</p> <p><input type="checkbox"/> 50m (170 ft) of relatively undisturbed vegetated areas, rocky areas, or open water > 95% circumference points = 4</p> <p><input type="checkbox"/> 100m (330 ft) of relatively undisturbed vegetated areas, rocky areas, or open water > 25% circumference points = 3</p> <p><input type="checkbox"/> 50m (170 ft) of relatively undisturbed vegetated areas, rocky areas, or open water for > 50% circumference points = 3</p> <p>If buffer does not meet any of the criteria above:</p> <p><input type="checkbox"/> No paved areas (except paved trails) or buildings within 25m (80 ft) of wetland > 95% circumference. Light to moderate grazing or lawns are OK points = 2</p> <p><input type="checkbox"/> No paved areas of buildings within 50m of wetland for > 50% circumference. Light to moderate grazing or lawns are OK points = 2</p> <p><input type="checkbox"/> Heavy grazing in buffer points = 1</p> <p><input type="checkbox"/> Vegetated buffers are < 2m wide (6.6 ft) for more than 95% circumference (e.g. tilled fields, paving, basalt bedrock extend to edge of wetland) points = 0</p> <p><input checked="" type="checkbox"/> Buffer does not meet any of the criteria above points = 1</p> <p style="text-align: right;">Arial photo showing buffers</p>	<p>Figure <input type="checkbox"/></p> <p style="text-align: right;">1</p>
	<p>H 2.2 <u>Corridors and Connections</u> (see p. 81)</p> <p>H 2.2.1 Is the wetland part of a relatively undisturbed and unbroken vegetated corridor (either riparian or upland) that is at least 150 ft. wide, has at least a 30% cover of shrubs, forest or native undisturbed prairie, that connects to estuaries, other wetlands or undisturbed uplands that are at least 250 acres in size? (<i>Dams in riparian corridors, heavily used gravel roads, paved roads, are considered breaks in the corridor.</i>)</p> <p style="text-align: center;"><input type="checkbox"/> YES = 4 points (go to H 2.3) <input checked="" type="checkbox"/> NO = go to H 2.2.2</p> <p>H. 2.2.2 Is the wetland part of a relatively undisturbed and unbroken vegetated corridor (either riparian or upland) that is at least 50 ft. wide, has at least 30% cover of shrubs or forest, and connects to estuaries, other wetlands or undisturbed uplands that are at least 25 acres in size? OR a Lake-fringe wetland, if it does not have an undisturbed corridor as in the question above?</p> <p style="text-align: center;"><input type="checkbox"/> YES = 2 points (go to H 2.3) <input checked="" type="checkbox"/> NO = go to H 2.2.3</p> <p>H. 2.2.3 Is the wetland:</p> <ul style="list-style-type: none"> • Within 5 mi (8km) of a brackish or salt water estuary OR • Within 3 miles of a large field or pasture (> 40 acres) OR • Within 1 mile of a lake greater than 20 acres? <p style="text-align: right;"><input type="checkbox"/> YES = 1 point <input checked="" type="checkbox"/> NO = 0 points</p>	<p style="text-align: right;">0</p>

Comments: _____

	<p>H 2.3 <u>Near or adjacent to other priority habitats listed by WDFW</u> (see p. 82): (see new and complete descriptions of WDFW priority habitats, and the counties in which they can be found, in the PHS report http://wdfw.wa.gov/hab/phslist.htm) Which of the following priority habitats are within 330 ft. (100m) of the wetland unit? <i>NOTE: the connections do not have to be relatively undisturbed.</i></p> <p><input type="checkbox"/> Aspen Stands: Pure or mixed stands of aspen greater than 0.4 ha (1 acre).</p> <p><input type="checkbox"/> Biodiversity Areas and Corridors: Areas of habitat that are relatively important to various species of native fish and wildlife (full descriptions in WDFW PHS report p. 152).</p> <p><input type="checkbox"/> Herbaceous Balds: Variable size patches of grass and forbs on shallow soils over bedrock.</p> <p><input type="checkbox"/> Old-growth/Mature forests: (Old-growth west of Cascade crest) Stands of at least 2 tree species, forming a multi-layered canopy with occasional small openings; with at least 20 trees/ha (8 trees/acre) > 81 cm (32 in) dbh or > 200 years of age. (Mature forests) Stands with average diameters exceeding 53 cm (21 in) dbh; crown cover may be less than 100%; decay, decadence, numbers of snags, and quantity of large downed material is generally less than that found in old-growth; 80 - 200 years old west of the Cascade crest.</p> <p><input type="checkbox"/> Oregon white Oak: Woodlands Stands of pure oak or oak/conifer associations where canopy coverage of the oak component is important (full descriptions in WDFW PHS report p. 158).</p> <p><input type="checkbox"/> Riparian: The area adjacent to aquatic systems with flowing water that contains elements of both aquatic and terrestrial ecosystems which mutually influence each other.</p> <p><input type="checkbox"/> Westside Prairies: Herbaceous, non-forested plant communities that can either take the form of a dry prairie or a wet prairie (full descriptions in WDFW PHS report p. 161).</p> <p><input type="checkbox"/> Instream: The combination of physical, biological, and chemical processes and conditions that interact to provide functional life history requirements for instream fish and wildlife resources.</p> <p><input type="checkbox"/> Nearshore: Relatively undisturbed nearshore habitats. These include Coastal Nearshore, Open Coast Nearshore, and Puget Sound Nearshore. (full descriptions of habitats and the definition of relatively undisturbed are in WDFW report: pp. 167-169 and glossary in Appendix A).</p> <p><input type="checkbox"/> Caves: A naturally occurring cavity, recess, void, or system of interconnected passages under the earth in soils, rock, ice, or other geological formations and is large enough to contain a human.</p> <p><input type="checkbox"/> Cliffs: Greater than 7.6 m (25 ft) high and occurring below 5000 ft.</p> <p><input type="checkbox"/> Talus: Homogenous areas of rock rubble ranging in average size 0.15 - 2.0 m (0.5 - 6.5 ft), composed of basalt, andesite, and/or sedimentary rock, including riprap slides and mine tailings. May be associated with cliffs.</p> <p><input type="checkbox"/> Snags and Logs: Trees are considered snags if they are dead or dying and exhibit sufficient decay characteristics to enable cavity excavation/use by wildlife. Priority snags have a diameter at breast height of > 51 cm (20 in) in western Washington and are > 2 m (6.5 ft) in height. Priority logs are > 30 cm (12 in) in diameter at the largest end, and > 6 m (20 ft) long.</p> <p style="text-align: right;">If wetland has 3 or more priority habitats = 4 points If wetland has 2 priority habitats = 3 points If wetland has 1 priority habitat = 1 point No habitats = 0 points</p> <p>Note: All vegetated wetlands are by definition a priority habitat but are not included in this list. Nearby wetlands are addressed in question H 2.4)</p>	0
	<p>H 2.4 <u>Wetland Landscape:</u> Choose the one description of the landscape around the wetland that best fits (see p. 84)</p> <ul style="list-style-type: none"> • There are at least 3 other wetlands within 1/2 mile, and the connections between them are relatively undisturbed (light grazing between wetlands OK, as is lake shore with some boating, but connections should NOT be bisected by paved roads, fill, fields, or other development.... points = 5 <input type="checkbox"/> • The wetland is Lake-fringe on a lake with little disturbance and there are 3 other lake-fringe wetlands within 1/2 mile points = 5 <input type="checkbox"/> • There are at least 3 other wetlands within 1/2 mile, BUT the connections between them are disturbed. points = 3 <input checked="" type="checkbox"/> • The wetland fringe on a lake with disturbance and there are 3 other lake-fringe wetlands within 1/2 mile points = 3 <input type="checkbox"/> • There is at least 1 wetland within 1/2 mile points = 2 <input type="checkbox"/> • There are no wetlands within 1/2 mile..... points = 0 <input type="checkbox"/> 	3
	<p>H 2 TOTAL Score – opportunity for providing habitat Add the scores from H2.1, H2.2, H2.3, H2.4</p>	4
	<p style="text-align: right;">TOTAL for H 1 from page 8</p>	6
◆	<p>Total Score for Habitat Functions Add the points for H 1 and H 2; then record the result on p. 1</p>	10

Comments: _____

CATEGORIZATION BASED ON SPECIAL CHARACTERISTICS

Please determine if the wetland meets the attributes described below and circle the appropriate answers and Category.

Wetland Type – Check off any criteria that apply to the wetland. Circle the Category when the appropriate criteria are met.	
SC1	<p>Estuarine wetlands? (see p.86)</p> <p>Does the wetland unit meet the following criteria for Estuarine wetlands?</p> <p><input type="checkbox"/> The dominant water regime is tidal, <input type="checkbox"/> Vegetated, and <input type="checkbox"/> With a salinity greater than 0.5 ppt.</p> <p style="text-align: center;"><input type="checkbox"/> YES = Go to SC 1.1 <input checked="" type="checkbox"/> NO</p>
	<p>SC 1.1 Is the wetland unit within a National Wildlife Refuge, National Park, National Estuary Reserve, Natural Area Preserve, State Park or Educational, Environmental, or Scientific Reserve designated under WAC 332-30-151? <input type="checkbox"/> YES = Category I <input type="checkbox"/> NO = go to SC 1.2</p>
	<p>SC 1.2 Is the wetland at least 1 acre in size and meets at least two of the following conditions?</p> <p style="text-align: center;"><input type="checkbox"/> YES = Category I <input type="checkbox"/> NO = Category II</p> <p><input type="checkbox"/> The wetland is relatively undisturbed (has no diking, ditching, filling, cultivation, grazing, and has less than 10% cover of non-native plant species. If the non-native <i>Spartina</i> spp. are only species that cover more than 10% of the wetland, then the wetland should be given a dual rating (I/II). The area of <i>Spartina</i> would be rated a Category II while the relatively undisturbed upper marsh with native species would be a Category I. Do not, however, exclude the area of <i>Spartina</i> in determining the size threshold of 1 acre.</p> <p><input type="checkbox"/> At least 3/4 of the landward edge of the wetland has a 100 ft. buffer of shrub, forest, or un-grazed or un-mowed grassland</p> <p><input type="checkbox"/> The wetland has at least 2 of the following features: tidal channels, depressions with open water, or contiguous freshwater wetlands.</p>
SC2	<p>Natural Heritage Wetlands (see p. 87)</p> <p>Natural Heritage wetlands have been identified by the Washington Natural Heritage Program/DNR as either high quality undisturbed wetlands or wetlands that support state Threatened, Endangered, or Sensitive plant species.</p> <p>SC 2.1 Is the wetland being rated in a Section/Township/Range that contains a natural heritage wetland? (This question is used to screen out most sites before you need to contact WNHP/DNR.)</p> <p style="text-align: center;"><input type="checkbox"/> S/T/R information from Appendix D <input type="checkbox"/> or accessed from WNHP/DNR web site <input type="checkbox"/> YES Contact WNHP/DNR (see p. 79) and go to SC 2.2 <input checked="" type="checkbox"/> NO</p> <p>SC 2.2 Has DNR identified the wetland as a high quality undisturbed wetland or as a site with state threatened or endangered plant species?</p> <p style="text-align: center;"><input type="checkbox"/> YES = Category 1 <input checked="" type="checkbox"/> NO not a Heritage Wetland</p>
SC3	<p>Bogs (see p. 87)</p> <p>Does the wetland (or any part of the unit) meet both the criteria for soils and vegetation in bogs? Use the key below to identify if the wetland is a bog. If you answer yes you will still need to rate the wetland based on its function.</p> <ol style="list-style-type: none"> Does the unit have organic soil horizons (i.e. layers of organic soil), either peats or mucks, that compose 16 inches or more of the first 32 inches of soil profile? (See Appendix B for a field key to identify organic soils)? <input type="checkbox"/> YES = go to question 3 <input checked="" type="checkbox"/> NO = go to question 2 Does the wetland have organic soils, either peats or mucks that are less than 16 inches deep over bedrock, or an impermeable hardpan such as clay or volcanic ash, or that are floating on a lake or pond? <input type="checkbox"/> YES = go to question 3 <input checked="" type="checkbox"/> NO = is not a bog for purpose of rating Does the unit have more than 70% cover of mosses at ground level, AND other plants, if present, consist of the “bog” species listed in Table 3 as a significant component of the vegetation (more than 30% of the total shrub and herbaceous cover consists of species in Table 3)? <p style="text-align: center;"><input type="checkbox"/> YES = Is a bog for purpose of rating <input checked="" type="checkbox"/> NO = go to question 4</p> <p>NOTE: If you are uncertain about the extent of mosses in the understory you may substitute that criterion by measuring the pH of the water that seeps into a hole dug at least 16” deep. If the pH is less than 5.0 and the “bog” plant species in Table 3 are present, the wetland is a bog.</p> <ol style="list-style-type: none"> Is the unit forested (> 30% cover) with sitka spruce, subalpine fir, western red cedar, western hemlock, lodgepole pine, quaking aspen, Englemann’s spruce, or western white pine. WITH any of the species (or combination of species) on the bog species plant list in Table 3 as a significant component of the ground cover (> 30% coverage of the total shrub/herbaceous cover)? <p style="text-align: center;"><input type="checkbox"/> YES = Category I <input checked="" type="checkbox"/> NO = Is not a bog for purpose of rating</p>

SC4	<p>Forested Wetlands (see p. 90)</p> <p>Does the wetland have at least 1 acre of forest that meet one of these criteria for the Department of Fish and Wildlife's forests as priority habitats? <i>If you answer yes you will still need to rate the wetland based on its function.</i></p> <p><input type="checkbox"/> Old-growth forests: (west of Cascade Crest) Stands of at least two three species forming a multi-layered canopy with occasional small openings; with at least 8 trees/acre (20 trees/hectare) that are at least 200 years of age OR have a diameter at breast height (dbh) of 32 inches (81 cm or more). NOTE: The criterion for dbh is based on measurements for upland forests. Two-hundred year old trees in wetlands will often have a smaller dbh because their growth rates are often slower. The DFW criterion is and "OR" so old-growth forests do not necessarily have to have trees of this diameter.</p> <p><input type="checkbox"/> Mature forests: (west of the Cascade Crest) Stands where the largest trees are 80 – 200 years old OR have an average diameters (dbh) exceeding 21 inches (53 cm); crown cover may be less than 100%; decay, decadence, numbers of snags, and quantity of large downed material is generally less than that found in old-growth.</p> <p><input type="checkbox"/> YES = Category I <input checked="" type="checkbox"/> NO = not a forested wetland with special characteristics</p>	<p>Cat. I <input type="checkbox"/></p>
SC5	<p>Wetlands in Coastal Lagoons (see p. 91)</p> <p>Does the wetland meet all of the following criteria of a wetland in a coastal lagoon?</p> <p><input type="checkbox"/> The wetland lies in a depression adjacent to marine waters that is wholly or partially separated from marine waters by sandbanks, gravel banks, shingle, or, less frequently, rocks.</p> <p><input type="checkbox"/> The lagoon in which the wetland is located contains surface water that is saline or brackish (> 0.5 ppt) during most of the year in at least a portion of the lagoon (<i>needs to be measured near the bottom.</i>)</p> <p><input type="checkbox"/> YES = Go to SC 5.1 <input checked="" type="checkbox"/> NO not a wetland in a coastal lagoon</p> <p>SC 5.1 Does the wetland meet all of the following three conditions?</p> <p><input type="checkbox"/> The wetland is relatively undisturbed (has no diking, ditching, filling, cultivation, grazing) and has less than 20% cover of invasive plant species (see list of invasive species on p. 74).</p> <p><input type="checkbox"/> At least 3/4 of the landward edge of the wetland has a 100 ft. buffer of shrub, forest, or un-grazed or un-mowed grassland.</p> <p><input type="checkbox"/> The wetland is larger than 1/10 acre (4350 square ft.)</p> <p><input type="checkbox"/> YES = Category I <input type="checkbox"/> NO = Category II</p>	<p>Cat. I <input type="checkbox"/></p> <p>Cat. II <input type="checkbox"/></p>
SC6	<p>Interdunal Wetlands (see p. 93)</p> <p>Is the wetland west of the 1889 line (also called the Western Boundary of Upland Ownership or WBUO)?</p> <p><input type="checkbox"/> YES = Go to SC 6.1 <input checked="" type="checkbox"/> NO not an interdunal wetland for rating</p> <p><i>If you answer yes you will still need to rate the wetland based on its functions.</i></p> <p>In practical terms that means the following geographic areas:</p> <ul style="list-style-type: none"> • Long Beach Peninsula -- lands west of SR 103 • Grayland-Westport -- lands west of SR 105 • Ocean Shores-Copalis – lands west of SR 115 and SR 109 <p>SC 6.1 Is the wetland one acre or larger, or is it in a mosaic of wetlands that is one acre or larger?</p> <p><input type="checkbox"/> YES = Category II <input type="checkbox"/> NO = go to SC 6.2</p> <p>SC 6.2 Is the wetland between 0.1 and 1 acre, or is it in a mosaic of wetlands that is between 0.1 and 1 acre?</p> <p><input type="checkbox"/> YES = Category III</p>	<p>Cat. II <input type="checkbox"/></p> <p>Cat. III <input type="checkbox"/></p>
◆	<p>Category of wetland based on Special Characteristics</p> <p>Choose the "highest" rating if wetland falls into several categories, and record on p. 1. If you answered NO for all types enter "Not Applicable" on p. 1</p>	<p>NA</p>

Comments:

WETLAND RATING FORM – WESTERN WASHINGTON
Version 2 – Updated July 2006 to increase accuracy and reproducibility among users
Updated Oct. 2008 with the new WDFW definitions for priority habitats

Name of wetland (if known): DPUHUqwj y guv

Date of site visit: April 23, 2013

Rated by: C. Douglas & J. Pursley Trained by Ecology? Yes No

Date of training: May 2007

SEC: 29 TOWNSHP: 24N RNGE: 5E

Is S/T/R in Appendix D? Yes No

Map of wetland unit: Figure _____ Estimated size _____

SUMMARY OF RATING

Category based on FUNCTIONS provided by wetland: I II III IV

Category I =	Score > 70
Category II =	Score 51 - 69
Category III =	Score 30 – 50
Category IV =	Score < 30

Score for Water Quality Functions	14
Score for Hydrologic Functions	16
Score for Habitat Functions	12
TOTAL Score for Functions	42

Category based on SPECIAL CHARACTERISTICS of Wetland I II Does not apply

Final Category (choose the “highest” category from above”)

III

Summary of basic information about the wetland unit.

Wetland Unit has Special Characteristics		Wetland HGM Class used for Rating	
Estuarine	<input type="checkbox"/>	Depressional	<input checked="" type="checkbox"/>
Natural Heritage Wetland	<input type="checkbox"/>	Riverine	<input type="checkbox"/>
Bog	<input type="checkbox"/>	Lake-fringe	<input type="checkbox"/>
Mature Forest	<input type="checkbox"/>	Slope	<input checked="" type="checkbox"/>
Old Growth Forest	<input type="checkbox"/>	Flats	<input type="checkbox"/>
Coastal Lagoon	<input type="checkbox"/>	Freshwater Tidal	<input type="checkbox"/>
Interdunal	<input type="checkbox"/>		<input type="checkbox"/>
None of the above	<input checked="" type="checkbox"/>	Check if unit has multiple HGM classes present	<input checked="" type="checkbox"/>

Does the wetland being rated meet any of the criteria below? If you answer YES to any of the questions below you will need to protect the wetland according to the regulations regarding the special characteristics found in the wetland.

Check List for Wetlands that Need Additional Protection (in addition to the protection recommended for its category)	YES	NO
SP1. <i>Has the wetland unit been documented as a habitat for any Federally listed Threatened or Endangered animal or plant species (T/E species)?</i> For the purposes of this rating system, “documented” means the wetland is on the appropriate state or federal database.	<input type="checkbox"/>	<input checked="" type="checkbox"/>
SP2. <i>Has the wetland unit been documented as habitat for any State listed Threatened or Endangered animal species?</i> For the purposes of this rating system, “documented” means the wetland is on the appropriate state database. Note: Wetlands with State listed plant species are categorized as Category 1 Natural Heritage Wetlands (see p. 19 of data form).	<input type="checkbox"/>	<input checked="" type="checkbox"/>
SP3. <i>Does the wetland unit contain individuals of Priority species listed by the WDFW for the state?</i>	<input type="checkbox"/>	<input checked="" type="checkbox"/>
SP4. <i>Does the wetland unit have a local significance in addition to its functions?</i> For example, the wetland has been identified in the Shoreline Master Program, the Critical Areas Ordinance, or in a local management plan as having special significance.	<input type="checkbox"/>	<input checked="" type="checkbox"/>

To complete the next part of the data sheet you will need to determine the Hydrogeomorphic Class of the wetland being rated.

The hydrogeomorphic classification groups wetlands in to those that function in similar ways. This simplifies the questions needed to answer how well the wetland functions. The Hydrogeomorphic Class of a wetland can be determined using the key below. See p. 24 for more detailed instructions on classifying wetlands.

Classification of Vegetated Wetlands for Western Washington

If the hydrologic criteria listed in each question do not apply to the entire unit being rated, you probably have a unit with multiple HGM classes. In this case, identify which hydrologic criteria in questions 1-7 apply, and go to Question 8.

1. Are the water levels in the entire unit usually controlled by tides (i.e. except during floods)?
 NO – go to 2 YES – the wetland class is **Tidal Fringe**
 If yes, is the salinity of the water during periods of annual low flow below 0.5 ppt (parts per thousand)?
 YES – **Freshwater Tidal Fringe** NO – **Saltwater Tidal Fringe (Estuarine)**
*If your wetland can be classified as a Freshwater Tidal Fringe use the forms for **Riverine** wetlands. If it is a Saltwater Tidal Fringe it is rated as an **Estuarine** wetland. Wetlands that were call estuarine in the first and second editions of the rating system are called Salt Water Tidal Fringe in the Hydrogeomorphic Classification. Estuarine wetlands were categorized separately in the earlier editions, and this separation is being kept in this revision. To maintain consistency between editions, the term “Estuarine” wetland is kept. Please note, however, that the characteristics that define Category I and II estuarine wetlands have changed (see p. _____).*
-
2. The entire wetland unit is flat and precipitation is only source (>90%) of water to it. Groundwater and surface water runoff are NOT sources of water to the unit.
 NO – go to 3 YES – The wetland class is **Flats**
 If your wetland can be classified as a “Flats” wetland, use the form for **Depressional** wetlands.
-
3. Does the entire wetland meet both of the following criteria?
 The vegetated part of the wetland is on the shores of a body of permanent open water (without any vegetation on the surface) where at least 20 acres (8ha) in size;
 At least 30% of the open water area is deeper than 6.6 (2 m)?
 NO – go to 4 YES – The wetland class is **Lake-fringe (Lacustrine Fringe)**
-
4. Does the entire wetland meet all of the following criteria?
 The wetland is on a slope (*slope can be very gradual*).
 The water flows through the wetland in one direction (unidirectional) and usually comes from seeps. It may flow subsurface, as sheetflow, or in a swale without distinct banks.
 The water leaves the wetland **without being impounded?**
 NOTE: *Surface water does not pond in these types of wetlands except occasionally in very small and shallow depressions or behind hummocks (depressions are usually <3 ft diameter and less than 1 foot deep).*
 NO – go to 5 YES – The wetland class is **Slope**
-
5. Does the entire wetland meet all of the following criteria?
 The unit is in a valley or stream channel where it gets inundated by overbank flooding from that stream or river.
 The overbank flooding occurs at least once every two years.
 NOTE: *The riverine unit can contain depressions that are filled with water when the river is not flooding..*
 NO – go to 6 YES – The wetland class is **Riverine**
-
6. Is the entire wetland unit in a topographic depression in which water ponds, or is saturated to the surface, at some time of the year. This means that any outlet, if present is higher than the interior of the wetland.
 NO – go to 7 YES – The wetland class is **Depressional**
-
7. Is the entire wetland located in a very flat area with no obvious depression and no overbank flooding. The unit does not pond surface water more than a few inches. The unit seems to be maintained by high groundwater in the area. The wetland may be ditched, but has no obvious natural outlet.
 No – go to 8 YES – The wetland class is **Depressional**
-
8. Your wetland unit seems to be difficult to classify and probably contains several different HGM classes. For example, seeps at the base of a slope may grade into a riverine floodplain, or a small stream within a depressional wetland has a zone of flooding along its sides. GO BACK AND IDENTIFY WHICH OF THE HYDROLOGIC REGIMES DESCRIBED IN QUESTIONS 1-7 APPLY TO DIFFERENT AREAS IN THE UNIT (make a rough sketch to help you decide). Use the following table to identify the appropriate class to use for the rating system if you have several HGM classes present within your wetland. NOTE: Use this table only if the class that is recommended in the second column represents 10% or more of the total area of the wetland unit being rated. If the area of the class listed in column 2 is less than 10% of the unit, classify the wetland using the class that represents more than 90% of the total area.

HGM Classes within the wetland unit being rated	HGM Class to Use in Rating
Slope + Riverine	Riverine
Slope + Depressional	Depressional
Slope + Lake-fringe	Lake-fringe
Depressional + Riverine along stream within boundary	Depressional
Depressional + Lake-fringe	Depressional
Salt Water Tidal Fringe and any other class of freshwater wetland	Treat as ESTUARINE under wetlands with special characteristics

If you are unable still to determine which of the above criteria apply to your wetland, or you have more than 2 HGM classes within a wetland boundary, classify the wetland as **Depressional** for the rating.

D Depressional and Flat Wetlands		Points
WATER QUALITY FUNCTIONS – Indicators that wetland functions to improve water quality.		(only 1 score per box) (see p.38)
D 1	Does the wetland have the <u>potential</u> to improve water quality?	
D 1.1	Characteristics of surface water flows out of the wetland: • Unit is a depression with no surface water leaving it (no outlet) points = 3 <input type="checkbox"/> • Unit has an intermittently flowing, OR highly constricted, permanently flowing outlet ... points = 2 <input checked="" type="checkbox"/> • Unit has an unconstricted, or slightly constricted, surface outlet (<i>permanently flowing</i>) .. points = 1 <input type="checkbox"/> • Unit is a “flat” depression (Q.7 on key), or in the Flats class, with permanent surface outflow and no obvious natural outlet and/or outlet is a man-made ditch..... points = 1 <input type="checkbox"/> <i>(If ditch is not permanently flowing treat unit as “intermittently flowing”)</i> Provide photo or drawing	Figure <input type="checkbox"/> 2
D 1.2	The soil 2 inches below the surface (or duff layer) is clay or organic (<i>use NRCS definitions</i>) YES points = 4 NO points = 0	0
D 1.3	Characteristics of persistent vegetation (emergent, shrub, and/or forest Cowardin class): • Wetland has persistent, ungrazed vegetation > = 95% of area..... points = 5 <input type="checkbox"/> • Wetland has persistent, ungrazed vegetation > = 1/2 of area..... points = 3 <input checked="" type="checkbox"/> • Wetland has persistent, ungrazed vegetation > = 1/10 of area..... points = 1 <input type="checkbox"/> • Wetland has persistent, ungrazed vegetation < 1/10 of area..... points = 0 <input type="checkbox"/> Map of Cowardin vegetation classes	Figure <input type="checkbox"/> 3
D 1.4	Characteristics of seasonal ponding or inundation: <i>This is the area of the wetland that is ponded for at least 2 months, but dries out sometime during the year. Do not count the area that is permanently ponded. Estimate area as the average condition 5 out of 10 years.</i> • Area seasonally ponded is > 1/2 total area of wetland points = 4 <input type="checkbox"/> • Area seasonally ponded is > 1/4 total area of wetland points = 2 <input checked="" type="checkbox"/> • Area seasonally ponded is < 1/4 total area of wetland points = 0 <input type="checkbox"/> Map of Hydroperiods	Figure <input type="checkbox"/> 2
Total for D 1		<i>Add the points in the boxes above</i> 7
D 2	Does the wetland have the <u>opportunity</u> to improve water quality?	(see p. 44)
Answer YES if you know or believe there are pollutants in groundwater or surface water coming into the wetland that would otherwise reduce water quality in streams, lakes or groundwater downgradient from the wetland? <i>Note which of the following conditions provide the sources of pollutants. A unit may have pollutants coming from several sources, but any single source would qualify as opportunity.</i> <input type="checkbox"/> Grazing in the wetland or within 150 ft <input checked="" type="checkbox"/> Untreated stormwater discharges to wetland <input type="checkbox"/> Tilled fields or orchards within 150 ft. of wetland <input checked="" type="checkbox"/> A stream or culvert discharges into wetland that drains developed areas, residential areas, farmed fields, roads, or clear-cut logging <input checked="" type="checkbox"/> Residential, urban areas, golf courses are within 150 ft. of wetland <input type="checkbox"/> Wetland is fed by groundwater high in phosphorus or nitrogen <input type="checkbox"/> Other _____		Multiplier 2
<input checked="" type="checkbox"/> YES multiplier is 2 <input type="checkbox"/> NO multiplier is 1		
◆ TOTAL – Water Quality Functions		Multiply the score from D1 by D2; then add score to table on p. 1 14
HYDROLOGIC FUNCTIONS – Indicators that wetland unit functions to reduce flooding and stream degradation.		
D 3	Does the wetland have the <u>potential</u> to reduce flooding and erosion?	(see p.46)
D 3.1	Characteristics of surface water flows out of the wetland unit • Unit is a depression with no surface water leaving it (no outlet) points = 4 <input type="checkbox"/> • Unit has an intermittently flowing, OR highly constricted permanently flowing outlet points = 2 <input checked="" type="checkbox"/> • Unit is a “flat” depression (Q.7 on key) or in the Flats class, with permanent surface outflow and no obvious natural outlet and/or outlet is a man-made ditch..... points = 1 <input type="checkbox"/> <i>(If ditch is not permanently flowing treat unit as “intermittently flowing”)</i> • Unit has an unconstricted, or slightly constricted, surface outlet (<i>permanently flowing</i>) points = 0	2
D 3.2	Depth of storage during wet periods. <i>Estimate the height of ponding above the bottom of the outlet. For units with no outlet measure from the surface of permanent water or deepest part (if dry).</i> • Marks of ponding are 3 ft. or more above the surface or bottom of the outlet points = 7 <input type="checkbox"/> • The wetland is a “headwater” wetland..... points = 5 <input type="checkbox"/> • Marks of ponding between 2 ft. to < 3 ft. from surface or bottom of outlet..... points = 5 <input type="checkbox"/> • Marks are at least 0.5 ft. to < 2 ft. from surface or bottom of outlet..... points = 3 <input checked="" type="checkbox"/> • Wetland is flat (yes to Q.2 or Q.7 on key) but has small depressions on the surface that trap water . points = 1 <input type="checkbox"/> • Marks of ponding less than 0.5 ft points = 0 <input type="checkbox"/>	3
D 3.3	Contribution of wetland unit to storage in the watershed: <i>Estimate the ratio of the area of upstream basin contributing surface water to the wetland to the area of the wetland unit itself.</i> • The area of the basin is less than 10 times the area of unit..... points = 5 <input type="checkbox"/> • The area of the basin is 10 to 100 times the area of the unit..... points = 3 <input checked="" type="checkbox"/> • The area of the basin is more than 100 times the area of the unit points = 0 <input type="checkbox"/> • Entire unit is in the FLATS class points = 5 <input type="checkbox"/>	3
Total for D 3		<i>Add the points in the boxes above</i> 8

D 4	<p>Does the wetland have the <u>opportunity</u> to reduce flooding and erosion?</p> <p>Answer YES if the unit is in a location in the watershed where the flood storage, or reduction in water velocity, it provides helps protect downstream property and aquatic resources from flooding or excessive and/or erosive flows. Answer NO if the water coming into the wetland is controlled by a structure such as flood gate, tide gate, flap valve, reservoir etc. OR you estimate that more than 90% of the water in the wetland is from groundwater in areas where damaging groundwater flooding does not occur. <i>Note which of the following indicators of opportunity apply.</i></p> <p><input type="checkbox"/> Wetland is in a headwater of a river or stream that has flooding problems.</p> <p><input checked="" type="checkbox"/> Wetland drains to a river or stream that has flooding problems</p> <p><input type="checkbox"/> Wetland has no outlet and impounds surface runoff water that might otherwise flow into a river or stream that has flooding problems</p> <p><input type="checkbox"/> Other _____</p> <p><input checked="" type="checkbox"/> YES multiplier is 2 <input type="checkbox"/> NO multiplier is 1</p>	<p>(see p. 49)</p> <p>Multiplier</p> <p>2</p>
◆	<p>TOTAL – Hydrologic Functions Multiply the score from D3 by D4; then <i>add score to table on p. 1</i></p>	<p><u>16</u></p>

Comments: _____

These questions apply to wetlands of all HGM classes.		Points																
HABITAT FUNCTIONS – Indicators that wetland functions to provide important habitat.		(only 1 score per box)																
H 1	Does the wetland have the potential to provide habitat for many species?																	
H 1.1	<p>Vegetation structure (see P. 72): Check the types of vegetation classes present (as defined by Cowardin) – Size threshold for each class is 1/4 acre or more than 10% of the area if unit is smaller than 2.5 acres.</p> <p><input type="checkbox"/> Aquatic Bed <input checked="" type="checkbox"/> Emergent plants <input checked="" type="checkbox"/> Scrub/shrub (areas where shrubs have > 30% cover) <input checked="" type="checkbox"/> Forested (areas where trees have > 30% cover)</p> <p>If the unit has a forested class check if: <input type="checkbox"/> The forested class has 3 out of 5 strata (canopy, sub-canopy, shrubs, herbaceous, moss/ground-cover) that each cover 20% within the forested polygon.</p> <p>Add the number of vegetation types that qualify. If you have:</p> <table style="width: 100%; border: none;"> <tr> <td style="width: 50%;">4 structures or more..... points = 4 <input type="checkbox"/></td> <td style="width: 50%; text-align: right;">Map of Cowardin vegetation classes</td> </tr> <tr> <td>2 structures..... points = 1 <input type="checkbox"/></td> <td style="text-align: right;">3 structures..... points = 2 <input checked="" type="checkbox"/></td> </tr> <tr> <td></td> <td style="text-align: right;">1 structure..... points = 0 <input type="checkbox"/></td> </tr> </table>	4 structures or more..... points = 4 <input type="checkbox"/>	Map of Cowardin vegetation classes	2 structures..... points = 1 <input type="checkbox"/>	3 structures..... points = 2 <input checked="" type="checkbox"/>		1 structure..... points = 0 <input type="checkbox"/>	<p>Figure <input type="checkbox"/></p> <p style="text-align: right;">2</p>										
4 structures or more..... points = 4 <input type="checkbox"/>	Map of Cowardin vegetation classes																	
2 structures..... points = 1 <input type="checkbox"/>	3 structures..... points = 2 <input checked="" type="checkbox"/>																	
	1 structure..... points = 0 <input type="checkbox"/>																	
H 1.2	<p>Hydroperiods (see p.73): Check the types of water regimes (hydroperiods) present within the wetland. The water regime has to cover more than 10% of the wetland or 1/4 acre to count (see text for descriptions of hydroperiods).</p> <table style="width: 100%; border: none;"> <tr> <td style="width: 50%;"><input type="checkbox"/> Permanently flooded or inundated</td> <td style="width: 50%;">4 or more types present</td> <td style="width: 10%;">points = 3</td> <td style="width: 10%;"><input type="checkbox"/></td> </tr> <tr> <td><input checked="" type="checkbox"/> Seasonally flooded or inundated</td> <td>3 or more types present</td> <td>points = 2</td> <td><input type="checkbox"/></td> </tr> <tr> <td><input checked="" type="checkbox"/> Occasionally flooded or inundated</td> <td>2 types present</td> <td>points = 1</td> <td><input checked="" type="checkbox"/></td> </tr> <tr> <td><input checked="" type="checkbox"/> Saturated only</td> <td>1 type present</td> <td>points = 0</td> <td><input type="checkbox"/></td> </tr> </table> <p><input type="checkbox"/> Permanently flowing stream or river in, or adjacent to, the wetland <input type="checkbox"/> Seasonally flowing stream in, or adjacent to, the wetland</p> <p><input type="checkbox"/> Lake-fringe wetland..... = 2 points <input type="checkbox"/> Freshwater tidal wetland..... = 2 points</p> <p style="text-align: right;">Map of hydroperiods</p>	<input type="checkbox"/> Permanently flooded or inundated	4 or more types present	points = 3	<input type="checkbox"/>	<input checked="" type="checkbox"/> Seasonally flooded or inundated	3 or more types present	points = 2	<input type="checkbox"/>	<input checked="" type="checkbox"/> Occasionally flooded or inundated	2 types present	points = 1	<input checked="" type="checkbox"/>	<input checked="" type="checkbox"/> Saturated only	1 type present	points = 0	<input type="checkbox"/>	<p>Figure <input type="checkbox"/></p> <p style="text-align: right;">1</p>
<input type="checkbox"/> Permanently flooded or inundated	4 or more types present	points = 3	<input type="checkbox"/>															
<input checked="" type="checkbox"/> Seasonally flooded or inundated	3 or more types present	points = 2	<input type="checkbox"/>															
<input checked="" type="checkbox"/> Occasionally flooded or inundated	2 types present	points = 1	<input checked="" type="checkbox"/>															
<input checked="" type="checkbox"/> Saturated only	1 type present	points = 0	<input type="checkbox"/>															
H 1.3	<p>Richness of Plant Species (see p. 75): Count the number of plant species in the wetland that cover at least 10 ft² (different patches of the same species can be combined to meet the size threshold) You do not have to name the species. Do not include Eurasian Milfoil, reed canarygrass, purple loosestrife, Canadian Thistle.</p> <p>If you counted:</p> <table style="width: 100%; border: none;"> <tr> <td style="width: 50%;">> 19 species..... points = 2</td> <td style="width: 10%;"><input type="checkbox"/></td> </tr> <tr> <td>5 – 19 species..... points = 1</td> <td><input checked="" type="checkbox"/></td> </tr> <tr> <td>< 5 species..... points = 0</td> <td><input type="checkbox"/></td> </tr> </table> <p>List species below if you want to:</p>	> 19 species..... points = 2	<input type="checkbox"/>	5 – 19 species..... points = 1	<input checked="" type="checkbox"/>	< 5 species..... points = 0	<input type="checkbox"/>	<p style="text-align: right;">1</p>										
> 19 species..... points = 2	<input type="checkbox"/>																	
5 – 19 species..... points = 1	<input checked="" type="checkbox"/>																	
< 5 species..... points = 0	<input type="checkbox"/>																	
H 1.4	<p>Interspersion of Habitats (see p. 76): Decided from the diagrams below whether interspersion between Cowardin vegetation (described in H1.1), or the classes and unvegetated areas (can include open water or mudflats) is high, medium, low, or none.</p> <div style="text-align: center;"> <p>None = 0 points Low = 1 point Moderate = 2 points</p> <p>High = 3 points [riparian braided channels]</p> </div> <p>Note: If you have 4 or more classes or 3 vegetation classes and open water, the rating is always “high”.</p> <p style="text-align: right;">Use map of Cowardin classes.</p>	<p>Figure <input type="checkbox"/></p> <p style="text-align: right;">2</p>																
H 1.5	<p>Special Habitat Features (see p. 77): Check the habitat features that are present in the wetland. The number of checks is the number of points you put into the next column.</p> <p><input checked="" type="checkbox"/> Large, downed, woody debris within the wetland (> 4 in. diameter and 6 ft. long) <input checked="" type="checkbox"/> Standing snags (diameter at the bottom > 4 inches) in the wetland <input type="checkbox"/> Undercut banks are present for at least 6.6 ft. (2m) and/or overhanging vegetation extends at least 3.3 ft. (1m) over a stream (or ditch) in, or contiguous with the unit, for at least 33 ft. (10m) <input type="checkbox"/> Stable steep banks of fine material that might be used by beaver or muskrat for denning (> 30 degree slope) OR signs of recent beaver activity are present (cut shrubs or trees that have not yet turned grey/brown) <input type="checkbox"/> At least 1/4 acre of thin-stemmed persistent vegetation or woody branches are present in areas that are permanently or seasonally inundated (structures for egg-laying by amphibians) <input type="checkbox"/> Invasive plants cover less than 25% of the wetland area in each stratum of plants</p> <p>NOTE: The 20% stated in early printings of the manual on page 78 is an error.</p>	<p style="text-align: right;">2</p>																
H 1 TOTAL Score – potential for providing habitat		8																

Add the points in the column above

H 2	Does the wetland have the <u>opportunity</u> to provide habitat for many species?	(only 1 score per box)
	<p>H 2.1 <u>Buffers</u> (see P. 80): Choose the description that best represents condition of buffer of wetland unit. The highest scoring criterion that applies to the wetland is to be used in the rating. See text for definition of "undisturbed".</p> <p><input type="checkbox"/> 100m (330 ft) of relatively undisturbed vegetated areas, rocky areas, or open water > 95% of circumference. No structures are within the undisturbed part of buffer (relatively undisturbed also means no grazing, no landscaping, no daily human use)..... points = 5</p> <p><input type="checkbox"/> 100m (330 ft) of relatively undisturbed vegetated areas, rocky areas, or open water > 50% circumference points = 4</p> <p><input type="checkbox"/> 50m (170 ft) of relatively undisturbed vegetated areas, rocky areas, or open water > 95% circumference points = 4</p> <p><input type="checkbox"/> 100m (330 ft) of relatively undisturbed vegetated areas, rocky areas, or open water > 25% circumference points = 3</p> <p><input type="checkbox"/> 50m (170 ft) of relatively undisturbed vegetated areas, rocky areas, or open water for > 50% circumference points = 3</p> <p>If buffer does not meet any of the criteria above:</p> <p><input type="checkbox"/> No paved areas (except paved trails) or buildings within 25m (80 ft) of wetland > 95% circumference. Light to moderate grazing or lawns are OK points = 2</p> <p><input type="checkbox"/> No paved areas of buildings within 50m of wetland for > 50% circumference. Light to moderate grazing or lawns are OK points = 2</p> <p><input type="checkbox"/> Heavy grazing in buffer points = 1</p> <p><input type="checkbox"/> Vegetated buffers are < 2m wide (6.6 ft) for more than 95% circumference (e.g. tilled fields, paving, basalt bedrock extend to edge of wetland) points = 0</p> <p><input checked="" type="checkbox"/> Buffer does not meet any of the criteria above points = 1</p> <p style="text-align: right;">Arial photo showing buffers</p>	<p>Figure <input type="checkbox"/></p> <p style="text-align: right;">1</p>
	<p>H 2.2 <u>Corridors and Connections</u> (see p. 81)</p> <p>H 2.2.1 Is the wetland part of a relatively undisturbed and unbroken vegetated corridor (either riparian or upland) that is at least 150 ft. wide, has at least a 30% cover of shrubs, forest or native undisturbed prairie, that connects to estuaries, other wetlands or undisturbed uplands that are at least 250 acres in size? (<i>Dams in riparian corridors, heavily used gravel roads, paved roads, are considered breaks in the corridor.</i>)</p> <p style="padding-left: 40px;"><input type="checkbox"/> YES = 4 points (go to H 2.3) <input checked="" type="checkbox"/> NO = go to H 2.2.2</p> <p>H. 2.2.2 Is the wetland part of a relatively undisturbed and unbroken vegetated corridor (either riparian or upland) that is at least 50 ft. wide, has at least 30% cover of shrubs or forest, and connects to estuaries, other wetlands or undisturbed uplands that are at least 25 acres in size? OR a Lake-fringe wetland, if it does not have an undisturbed corridor as in the question above?</p> <p style="padding-left: 40px;"><input type="checkbox"/> YES = 2 points (go to H 2.3) <input checked="" type="checkbox"/> NO = go to H 2.2.3</p> <p>H. 2.2.3 Is the wetland:</p> <ul style="list-style-type: none"> • Within 5 mi (8km) of a brackish or salt water estuary OR • Within 3 miles of a large field or pasture (> 40 acres) OR • Within 1 mile of a lake greater than 20 acres? <p style="text-align: right; padding-right: 40px;"><input type="checkbox"/> YES = 1 point <input checked="" type="checkbox"/> NO = 0 points</p>	<p style="text-align: right;">0</p>

Comments: _____

	<p>H 2.3 <u>Near or adjacent to other priority habitats listed by WDFW</u> (see p. 82): (see new and complete descriptions of WDFW priority habitats, and the counties in which they can be found, in the PHS report http://wdfw.wa.gov/hab/phslist.htm)</p> <p>Which of the following priority habitats are within 330 ft. (100m) of the wetland unit? NOTE: the connections do not have to be relatively undisturbed.</p> <p><input type="checkbox"/> Aspen Stands: Pure or mixed stands of aspen greater than 0.4 ha (1 acre).</p> <p><input type="checkbox"/> Biodiversity Areas and Corridors: Areas of habitat that are relatively important to various species of native fish and wildlife (full descriptions in WDFW PHS report p. 152).</p> <p><input type="checkbox"/> Herbaceous Balds: Variable size patches of grass and forbs on shallow soils over bedrock.</p> <p><input type="checkbox"/> Old-growth/Mature forests: (Old-growth west of Cascade crest) Stands of at least 2 tree species, forming a multi-layered canopy with occasional small openings; with at least 20 trees/ha (8 trees/acre) > 81 cm (32 in) dbh or > 200 years of age. (Mature forests) Stands with average diameters exceeding 53 cm (21 in) dbh; crown cover may be less than 100%; decay, decadence, numbers of snags, and quantity of large downed material is generally less than that found in old-growth; 80 - 200 years old west of the Cascade crest.</p> <p><input type="checkbox"/> Oregon white Oak: Woodlands Stands of pure oak or oak/conifer associations where canopy coverage of the oak component is important (full descriptions in WDFW PHS report p. 158).</p> <p><input type="checkbox"/> Riparian: The area adjacent to aquatic systems with flowing water that contains elements of both aquatic and terrestrial ecosystems which mutually influence each other.</p> <p><input type="checkbox"/> Westside Prairies: Herbaceous, non-forested plant communities that can either take the form of a dry prairie or a wet prairie (full descriptions in WDFW PHS report p. 161).</p> <p><input type="checkbox"/> Instream: The combination of physical, biological, and chemical processes and conditions that interact to provide functional life history requirements for instream fish and wildlife resources.</p> <p><input type="checkbox"/> Nearshore: Relatively undisturbed nearshore habitats. These include Coastal Nearshore, Open Coast Nearshore, and Puget Sound Nearshore. (full descriptions of habitats and the definition of relatively undisturbed are in WDFW report: pp. 167-169 and glossary in Appendix A).</p> <p><input type="checkbox"/> Caves: A naturally occurring cavity, recess, void, or system of interconnected passages under the earth in soils, rock, ice, or other geological formations and is large enough to contain a human.</p> <p><input type="checkbox"/> Cliffs: Greater than 7.6 m (25 ft) high and occurring below 5000 ft.</p> <p><input type="checkbox"/> Talus: Homogenous areas of rock rubble ranging in average size 0.15 - 2.0 m (0.5 - 6.5 ft), composed of basalt, andesite, and/or sedimentary rock, including riprap slides and mine tailings. May be associated with cliffs.</p> <p><input type="checkbox"/> Snags and Logs: Trees are considered snags if they are dead or dying and exhibit sufficient decay characteristics to enable cavity excavation/use by wildlife. Priority snags have a diameter at breast height of > 51 cm (20 in) in western Washington and are > 2 m (6.5 ft) in height. Priority logs are > 30 cm (12 in) in diameter at the largest end, and > 6 m (20 ft) long.</p> <p style="text-align: right;">If wetland has 3 or more priority habitats = 4 points If wetland has 2 priority habitats = 3 points If wetland has 1 priority habitat = 1 point No habitats = 0 points</p> <p>Note: All vegetated wetlands are by definition a priority habitat but are not included in this list. Nearby wetlands are addressed in question H 2.4)</p>	0
	<p>H 2.4 <u>Wetland Landscape:</u> Choose the one description of the landscape around the wetland that best fits (see p. 84)</p> <ul style="list-style-type: none"> • There are at least 3 other wetlands within 1/2 mile, and the connections between them are relatively undisturbed (light grazing between wetlands OK, as is lake shore with some boating, but connections should NOT be bisected by paved roads, fill, fields, or other development.... points = 5 <input type="checkbox"/> • The wetland is Lake-fringe on a lake with little disturbance and there are 3 other lake-fringe wetlands within 1/2 mile points = 5 <input type="checkbox"/> • There are at least 3 other wetlands within 1/2 mile, BUT the connections between them are disturbed. points = 3 <input checked="" type="checkbox"/> • The wetland fringe on a lake with disturbance and there are 3 other lake-fringe wetlands within 1/2 mile points = 3 <input type="checkbox"/> • There is at least 1 wetland within 1/2 mile points = 2 <input type="checkbox"/> • There are no wetlands within 1/2 mile..... points = 0 <input type="checkbox"/> 	3
	<p>H 2 TOTAL Score – opportunity for providing habitat Add the scores from H2.1, H2.2, H2.3, H2.4</p>	4
	<p>TOTAL for H 1 from page 8</p>	8
◆	<p>Total Score for Habitat Functions Add the points for H 1 and H 2; then record the result on p. 1</p>	12

Comments: _____

CATEGORIZATION BASED ON SPECIAL CHARACTERISTICS

Please determine if the wetland meets the attributes described below and circle the appropriate answers and Category.

Wetland Type – Check off any criteria that apply to the wetland. Circle the Category when the appropriate criteria are met.	
SC1	<p>Estuarine wetlands? (see p.86)</p> <p>Does the wetland unit meet the following criteria for Estuarine wetlands?</p> <p><input type="checkbox"/> The dominant water regime is tidal, <input type="checkbox"/> Vegetated, and <input type="checkbox"/> With a salinity greater than 0.5 ppt.</p> <p style="text-align: center;"><input type="checkbox"/> YES = Go to SC 1.1 <input checked="" type="checkbox"/> NO</p>
	<p>SC 1.1 Is the wetland unit within a National Wildlife Refuge, National Park, National Estuary Reserve, Natural Area Preserve, State Park or Educational, Environmental, or Scientific Reserve designated under WAC 332-30-151? <input type="checkbox"/> YES = Category I <input type="checkbox"/> NO = go to SC 1.2</p>
	<p>SC 1.2 Is the wetland at least 1 acre in size and meets at least two of the following conditions?</p> <p style="text-align: center;"><input type="checkbox"/> YES = Category I <input type="checkbox"/> NO = Category II</p> <p><input type="checkbox"/> The wetland is relatively undisturbed (has no diking, ditching, filling, cultivation, grazing, and has less than 10% cover of non-native plant species. If the non-native <i>Spartina</i> spp. are only species that cover more than 10% of the wetland, then the wetland should be given a dual rating (I/II). The area of <i>Spartina</i> would be rated a Category II while the relatively undisturbed upper marsh with native species would be a Category I. Do not, however, exclude the area of <i>Spartina</i> in determining the size threshold of 1 acre.</p> <p><input type="checkbox"/> At least 3/4 of the landward edge of the wetland has a 100 ft. buffer of shrub, forest, or un-grazed or un-mowed grassland</p> <p><input type="checkbox"/> The wetland has at least 2 of the following features: tidal channels, depressions with open water, or contiguous freshwater wetlands.</p>
SC2	<p>Natural Heritage Wetlands (see p. 87)</p> <p>Natural Heritage wetlands have been identified by the Washington Natural Heritage Program/DNR as either high quality undisturbed wetlands or wetlands that support state Threatened, Endangered, or Sensitive plant species.</p> <p>SC 2.1 Is the wetland being rated in a Section/Township/Range that contains a natural heritage wetland? (This question is used to screen out most sites before you need to contact WNHP/DNR.)</p> <p style="text-align: center;"><input type="checkbox"/> S/T/R information from Appendix D <input type="checkbox"/> or accessed from WNHP/DNR web site <input type="checkbox"/> YES Contact WNHP/DNR (see p. 79) and go to SC 2.2 <input checked="" type="checkbox"/> NO</p> <p>SC 2.2 Has DNR identified the wetland as a high quality undisturbed wetland or as a site with state threatened or endangered plant species?</p> <p style="text-align: center;"><input type="checkbox"/> YES = Category 1 <input checked="" type="checkbox"/> NO not a Heritage Wetland</p>
SC3	<p>Bogs (see p. 87)</p> <p>Does the wetland (or any part of the unit) meet both the criteria for soils and vegetation in bogs? Use the key below to identify if the wetland is a bog. If you answer yes you will still need to rate the wetland based on its function.</p> <ol style="list-style-type: none"> Does the unit have organic soil horizons (i.e. layers of organic soil), either peats or mucks, that compose 16 inches or more of the first 32 inches of soil profile? (See Appendix B for a field key to identify organic soils)? <input type="checkbox"/> YES = go to question 3 <input checked="" type="checkbox"/> NO = go to question 2 Does the wetland have organic soils, either peats or mucks that are less than 16 inches deep over bedrock, or an impermeable hardpan such as clay or volcanic ash, or that are floating on a lake or pond? <input type="checkbox"/> YES = go to question 3 <input checked="" type="checkbox"/> NO = is not a bog for purpose of rating Does the unit have more than 70% cover of mosses at ground level, AND other plants, if present, consist of the “bog” species listed in Table 3 as a significant component of the vegetation (more than 30% of the total shrub and herbaceous cover consists of species in Table 3)? <p style="text-align: center;"><input type="checkbox"/> YES = Is a bog for purpose of rating <input checked="" type="checkbox"/> NO = go to question 4</p> <p>NOTE: If you are uncertain about the extent of mosses in the understory you may substitute that criterion by measuring the pH of the water that seeps into a hole dug at least 16” deep. If the pH is less than 5.0 and the “bog” plant species in Table 3 are present, the wetland is a bog.</p> <ol style="list-style-type: none"> Is the unit forested (> 30% cover) with sitka spruce, subalpine fir, western red cedar, western hemlock, lodgepole pine, quaking aspen, Englemann’s spruce, or western white pine. WITH any of the species (or combination of species) on the bog species plant list in Table 3 as a significant component of the ground cover (> 30% coverage of the total shrub/herbaceous cover)? <p style="text-align: center;"><input type="checkbox"/> YES = Category I <input checked="" type="checkbox"/> NO = Is not a bog for purpose of rating</p>
	<p>Cat. I <input type="checkbox"/></p> <p>Cat. II <input type="checkbox"/></p> <p>Dual Rating I/II <input type="checkbox"/></p> <p>Cat I <input type="checkbox"/></p> <p>Cat. I <input type="checkbox"/></p>

SC4	<p>Forested Wetlands (see p. 90)</p> <p>Does the wetland have at least 1 acre of forest that meet one of these criteria for the Department of Fish and Wildlife’s forests as priority habitats? <i>If you answer yes you will still need to rate the wetland based on its function.</i></p> <p><input type="checkbox"/> Old-growth forests: (west of Cascade Crest) Stands of at least two three species forming a multi-layered canopy with occasional small openings; with at least 8 trees/acre (20 trees/hectare) that are at least 200 years of age OR have a diameter at breast height (dbh) of 32 inches (81 cm or more). NOTE: The criterion for dbh is based on measurements for upland forests. Two-hundred year old trees in wetlands will often have a smaller dbh because their growth rates are often slower. The DFW criterion is and “OR” so old-growth forests do not necessarily have to have trees of this diameter.</p> <p><input type="checkbox"/> Mature forests: (west of the Cascade Crest) Stands where the largest trees are 80 – 200 years old OR have an average diameters (dbh) exceeding 21 inches (53 cm); crown cover may be less than 100%; decay, decadence, numbers of snags, and quantity of large downed material is generally less than that found in old-growth.</p> <p><input type="checkbox"/> YES = Category I <input checked="" type="checkbox"/> NO = not a forested wetland with special characteristics</p>	<p>Cat. I <input type="checkbox"/></p>
SC5	<p>Wetlands in Coastal Lagoons (see p. 91)</p> <p>Does the wetland meet all of the following criteria of a wetland in a coastal lagoon?</p> <p><input type="checkbox"/> The wetland lies in a depression adjacent to marine waters that is wholly or partially separated from marine waters by sandbanks, gravel banks, shingle, or, less frequently, rocks.</p> <p><input type="checkbox"/> The lagoon in which the wetland is located contains surface water that is saline or brackish (> 0.5 ppt) during most of the year in at least a portion of the lagoon (<i>needs to be measured near the bottom.</i>)</p> <p><input type="checkbox"/> YES = Go to SC 5.1 <input checked="" type="checkbox"/> NO not a wetland in a coastal lagoon</p> <p>SC 5.1 Does the wetland meet all of the following three conditions?</p> <p><input type="checkbox"/> The wetland is relatively undisturbed (has no diking, ditching, filling, cultivation, grazing) and has less than 20% cover of invasive plant species (see list of invasive species on p. 74).</p> <p><input type="checkbox"/> At least 3/4 of the landward edge of the wetland has a 100 ft. buffer of shrub, forest, or un-grazed or un-mowed grassland.</p> <p><input type="checkbox"/> The wetland is larger than 1/10 acre (4350 square ft.)</p> <p><input type="checkbox"/> YES = Category I <input type="checkbox"/> NO = Category II</p>	<p>Cat. I <input type="checkbox"/></p> <p>Cat. II <input type="checkbox"/></p>
SC6	<p>Interdunal Wetlands (see p. 93)</p> <p>Is the wetland west of the 1889 line (also called the Western Boundary of Upland Ownership or WBUO)?</p> <p><input type="checkbox"/> YES = Go to SC 6.1 <input checked="" type="checkbox"/> NO not an interdunal wetland for rating</p> <p><i>If you answer yes you will still need to rate the wetland based on its functions.</i></p> <p>In practical terms that means the following geographic areas:</p> <ul style="list-style-type: none"> • Long Beach Peninsula -- lands west of SR 103 • Grayland-Westport -- lands west of SR 105 • Ocean Shores-Copalis – lands west of SR 115 and SR 109 <p>SC 6.1 Is the wetland one acre or larger, or is it in a mosaic of wetlands that is one acre or larger?</p> <p><input type="checkbox"/> YES = Category II <input type="checkbox"/> NO = go to SC 6.2</p> <p>SC 6.2 Is the wetland between 0.1 and 1 acre, or is it in a mosaic of wetlands that is between 0.1 and 1 acre?</p> <p><input type="checkbox"/> YES = Category III</p>	<p>Cat. II <input type="checkbox"/></p> <p>Cat. III <input type="checkbox"/></p>
◆	<p>Category of wetland based on Special Characteristics</p> <p><i>Choose the “highest” rating if wetland falls into several categories, and record on p. 1.</i></p> <p>If you answered NO for all types enter “Not Applicable” on p. 1</p>	<p>NA</p>

Comments:

WETLAND RATING FORM – WESTERN WASHINGTON
Version 2 – Updated July 2006 to increase accuracy and reproducibility among users
Updated Oct. 2008 with the new WDFW definitions for priority habitats

Name of wetland (if known): BNSF West

Date of site visit: April 23, 2013

Rated by: C. Douglas & J. Pursley Trained by Ecology? Yes No

Date of training: May 2007

SEC: 29

TOWNSHP: 24N

RNGE: 5E

Is S/T/R in Appendix D? Yes No

Map of wetland unit: Figure _____ Estimated size _____

SUMMARY OF RATING

Category based on FUNCTIONS provided by wetland: I II III IV

Category I =	Score > 70
Category II =	Score 51 - 69
Category III =	Score 30 – 50
Category IV =	Score < 30

Score for Water Quality Functions	14
Score for Hydrologic Functions	16
Score for Habitat Functions	12
TOTAL Score for Functions	42

Category based on SPECIAL CHARACTERISTICS of Wetland I II Does not apply

Final Category (choose the “highest” category from above”)

III

Summary of basic information about the wetland unit.

Wetland Unit has Special Characteristics		Wetland HGM Class used for Rating	
Estuarine	<input type="checkbox"/>	Depressional	<input checked="" type="checkbox"/>
Natural Heritage Wetland	<input type="checkbox"/>	Riverine	<input type="checkbox"/>
Bog	<input type="checkbox"/>	Lake-fringe	<input type="checkbox"/>
Mature Forest	<input type="checkbox"/>	Slope	<input checked="" type="checkbox"/>
Old Growth Forest	<input type="checkbox"/>	Flats	<input type="checkbox"/>
Coastal Lagoon	<input type="checkbox"/>	Freshwater Tidal	<input type="checkbox"/>
Interdunal	<input type="checkbox"/>		<input type="checkbox"/>
None of the above	<input checked="" type="checkbox"/>	Check if unit has multiple HGM classes present	<input checked="" type="checkbox"/>

Does the wetland being rated meet any of the criteria below? If you answer YES to any of the questions below you will need to protect the wetland according to the regulations regarding the special characteristics found in the wetland.

Check List for Wetlands that Need Additional Protection (in addition to the protection recommended for its category)	YES	NO
SP1. <i>Has the wetland unit been documented as a habitat for any Federally listed Threatened or Endangered animal or plant species (T/E species)?</i> For the purposes of this rating system, “documented” means the wetland is on the appropriate state or federal database.	<input type="checkbox"/>	<input checked="" type="checkbox"/>
SP2. <i>Has the wetland unit been documented as habitat for any State listed Threatened or Endangered animal species?</i> For the purposes of this rating system, “documented” means the wetland is on the appropriate state database. Note: Wetlands with State listed plant species are categorized as Category 1 Natural Heritage Wetlands (see p. 19 of data form).	<input type="checkbox"/>	<input checked="" type="checkbox"/>
SP3. <i>Does the wetland unit contain individuals of Priority species listed by the WDFW for the state?</i>	<input type="checkbox"/>	<input checked="" type="checkbox"/>
SP4. <i>Does the wetland unit have a local significance in addition to its functions?</i> For example, the wetland has been identified in the Shoreline Master Program, the Critical Areas Ordinance, or in a local management plan as having special significance.	<input type="checkbox"/>	<input checked="" type="checkbox"/>

To complete the next part of the data sheet you will need to determine the Hydrogeomorphic Class of the wetland being rated.

The hydrogeomorphic classification groups wetlands in to those that function in similar ways. This simplifies the questions needed to answer how well the wetland functions. The Hydrogeomorphic Class of a wetland can be determined using the key below. See p. 24 for more detailed instructions on classifying wetlands.

Classification of Vegetated Wetlands for Western Washington

If the hydrologic criteria listed in each question do not apply to the entire unit being rated, you probably have a unit with multiple HGM classes. In this case, identify which hydrologic criteria in questions 1-7 apply, and go to Question 8.

1. Are the water levels in the entire unit usually controlled by tides (i.e. except during floods)?
 NO – go to 2 YES – the wetland class is **Tidal Fringe**
 If yes, is the salinity of the water during periods of annual low flow below 0.5 ppt (parts per thousand)?
 YES – **Freshwater Tidal Fringe** NO – **Saltwater Tidal Fringe (Estuarine)**
*If your wetland can be classified as a Freshwater Tidal Fringe use the forms for **Riverine** wetlands. If it is a Saltwater Tidal Fringe it is rated as an **Estuarine** wetland. Wetlands that were call estuarine in the first and second editions of the rating system are called Salt Water Tidal Fringe in the Hydrogeomorphic Classification. Estuarine wetlands were categorized separately in the earlier editions, and this separation is being kept in this revision. To maintain consistency between editions, the term “Estuarine” wetland is kept. Please note, however, that the characteristics that define Category I and II estuarine wetlands have changed (see p. _____).*
-
2. The entire wetland unit is flat and precipitation is only source (>90%) of water to it. Groundwater and surface water runoff are NOT sources of water to the unit.
 NO – go to 3 YES – The wetland class is **Flats**
 If your wetland can be classified as a “Flats” wetland, use the form for **Depressional** wetlands.
-
3. Does the entire wetland meet both of the following criteria?
 The vegetated part of the wetland is on the shores of a body of permanent open water (without any vegetation on the surface) where at least 20 acres (8ha) in size;
 At least 30% of the open water area is deeper than 6.6 (2 m)?
 NO – go to 4 YES – The wetland class is **Lake-fringe (Lacustrine Fringe)**
-
4. Does the entire wetland meet all of the following criteria?
 The wetland is on a slope (*slope can be very gradual*).
 The water flows through the wetland in one direction (unidirectional) and usually comes from seeps. It may flow subsurface, as sheetflow, or in a swale without distinct banks.
 The water leaves the wetland **without being impounded?**
 NOTE: *Surface water does not pond in these types of wetlands except occasionally in very small and shallow depressions or behind hummocks (depressions are usually <3 ft diameter and less than 1 foot deep).*
 NO – go to 5 YES – The wetland class is **Slope**
-
5. Does the entire wetland meet all of the following criteria?
 The unit is in a valley or stream channel where it gets inundated by overbank flooding from that stream or river.
 The overbank flooding occurs at least once every two years.
 NOTE: *The riverine unit can contain depressions that are filled with water when the river is not flooding..*
 NO – go to 6 YES – The wetland class is **Riverine**
-
6. Is the entire wetland unit in a topographic depression in which water ponds, or is saturated to the surface, at some time of the year. This means that any outlet, if present is higher than the interior of the wetland.
 NO – go to 7 YES – The wetland class is **Depressional**
-
7. Is the entire wetland located in a very flat area with no obvious depression and no overbank flooding. The unit does not pond surface water more than a few inches. The unit seems to be maintained by high groundwater in the area. The wetland may be ditched, but has no obvious natural outlet.
 No – go to 8 YES – The wetland class is **Depressional**
-
8. Your wetland unit seems to be difficult to classify and probably contains several different HGM classes. For example, seeps at the base of a slope may grade into a riverine floodplain, or a small stream within a depressional wetland has a zone of flooding along its sides. GO BACK AND IDENTIFY WHICH OF THE HYDROLOGIC REGIMES DESCRIBED IN QUESTIONS 1-7 APPLY TO DIFFERENT AREAS IN THE UNIT (make a rough sketch to help you decide). Use the following table to identify the appropriate class to use for the rating system if you have several HGM classes present within your wetland. NOTE: Use this table only if the class that is recommended in the second column represents 10% or more of the total area of the wetland unit being rated. If the area of the class listed in column 2 is less than 10% of the unit, classify the wetland using the class that represents more than 90% of the total area.

HGM Classes within the wetland unit being rated	HGM Class to Use in Rating
Slope + Riverine	Riverine
Slope + Depressional	Depressional
Slope + Lake-fringe	Lake-fringe
Depressional + Riverine along stream within boundary	Depressional
Depressional + Lake-fringe	Depressional
Salt Water Tidal Fringe and any other class of freshwater wetland	Treat as ESTUARINE under wetlands with special characteristics

If you are unable still to determine which of the above criteria apply to your wetland, or you have more than 2 HGM classes within a wetland boundary, classify the wetland as **Depressional** for the rating.

D Depressional and Flat Wetlands		Points
WATER QUALITY FUNCTIONS – Indicators that wetland functions to improve water quality.		(only 1 score per box) (see p.38)
D 1	Does the wetland have the <u>potential</u> to improve water quality?	
D 1.1	Characteristics of surface water flows out of the wetland: • Unit is a depression with no surface water leaving it (no outlet) points = 3 <input type="checkbox"/> • Unit has an intermittently flowing, OR highly constricted, permanently flowing outlet ... points = 2 <input checked="" type="checkbox"/> • Unit has an unconstricted, or slightly constricted, surface outlet (<i>permanently flowing</i>) .. points = 1 <input type="checkbox"/> • Unit is a “flat” depression (Q.7 on key), or in the Flats class, with permanent surface outflow and no obvious natural outlet and/or outlet is a man-made ditch..... points = 1 <input type="checkbox"/> <i>(If ditch is not permanently flowing treat unit as “intermittently flowing”)</i> Provide photo or drawing	Figure <input type="checkbox"/> 2
D 1.2	The soil 2 inches below the surface (or duff layer) is clay or organic (<i>use NRCS definitions</i>) YES points = 4 NO points = 0	0
D 1.3	Characteristics of persistent vegetation (emergent, shrub, and/or forest Cowardin class): • Wetland has persistent, ungrazed vegetation > = 95% of area points = 5 <input type="checkbox"/> • Wetland has persistent, ungrazed vegetation > = 1/2 of area points = 3 <input checked="" type="checkbox"/> • Wetland has persistent, ungrazed vegetation > = 1/10 of area points = 1 <input type="checkbox"/> • Wetland has persistent, ungrazed vegetation < 1/10 of area points = 0 <input type="checkbox"/> Map of Cowardin vegetation classes	Figure <input type="checkbox"/> 3
D 1.4	Characteristics of seasonal ponding or inundation: <i>This is the area of the wetland that is ponded for at least 2 months, but dries out sometime during the year. Do not count the area that is permanently ponded. Estimate area as the average condition 5 out of 10 years.</i> • Area seasonally ponded is > 1/2 total area of wetland points = 4 <input type="checkbox"/> • Area seasonally ponded is > 1/4 total area of wetland points = 2 <input checked="" type="checkbox"/> • Area seasonally ponded is < 1/4 total area of wetland points = 0 <input type="checkbox"/> Map of Hydroperiods	Figure <input type="checkbox"/> 2
Total for D 1		<i>Add the points in the boxes above</i> 7
D 2	Does the wetland have the <u>opportunity</u> to improve water quality?	(see p. 44)
Answer YES if you know or believe there are pollutants in groundwater or surface water coming into the wetland that would otherwise reduce water quality in streams, lakes or groundwater downgradient from the wetland? <i>Note which of the following conditions provide the sources of pollutants. A unit may have pollutants coming from several sources, but any single source would qualify as opportunity.</i> <input type="checkbox"/> Grazing in the wetland or within 150 ft <input checked="" type="checkbox"/> Untreated stormwater discharges to wetland <input type="checkbox"/> Tilled fields or orchards within 150 ft. of wetland <input checked="" type="checkbox"/> A stream or culvert discharges into wetland that drains developed areas, residential areas, farmed fields, roads, or clear-cut logging <input checked="" type="checkbox"/> Residential, urban areas, golf courses are within 150 ft. of wetland <input type="checkbox"/> Wetland is fed by groundwater high in phosphorus or nitrogen <input type="checkbox"/> Other _____		Multiplier 2
<input checked="" type="checkbox"/> YES multiplier is 2 <input type="checkbox"/> NO multiplier is 1		
◆ TOTAL – Water Quality Functions		Multiply the score from D1 by D2; then add score to table on p. 1 14
HYDROLOGIC FUNCTIONS – Indicators that wetland unit functions to reduce flooding and stream degradation.		
D 3	Does the wetland have the <u>potential</u> to reduce flooding and erosion?	(see p.46)
D 3.1	Characteristics of surface water flows out of the wetland unit • Unit is a depression with no surface water leaving it (no outlet) points = 4 <input type="checkbox"/> • Unit has an intermittently flowing, OR highly constricted permanently flowing outlet points = 2 <input checked="" type="checkbox"/> • Unit is a “flat” depression (Q.7 on key) or in the Flats class, with permanent surface outflow and no obvious natural outlet and/or outlet is a man-made ditch..... points = 1 <input type="checkbox"/> <i>(If ditch is not permanently flowing treat unit as “intermittently flowing”)</i> • Unit has an unconstricted, or slightly constricted, surface outlet (<i>permanently flowing</i>) points = 0	2
D 3.2	Depth of storage during wet periods. <i>Estimate the height of ponding above the bottom of the outlet. For units with no outlet measure from the surface of permanent water or deepest part (if dry).</i> • Marks of ponding are 3 ft. or more above the surface or bottom of the outlet points = 7 <input type="checkbox"/> • The wetland is a “headwater” wetland..... points = 5 <input type="checkbox"/> • Marks of ponding between 2 ft. to < 3 ft. from surface or bottom of outlet points = 5 <input type="checkbox"/> • Marks are at least 0.5 ft. to < 2 ft. from surface or bottom of outlet points = 3 <input checked="" type="checkbox"/> • Wetland is flat (yes to Q.2 or Q.7 on key) but has small depressions on the surface that trap water . points = 1 <input type="checkbox"/> • Marks of ponding less than 0.5 ft points = 0 <input type="checkbox"/>	3
D 3.3	Contribution of wetland unit to storage in the watershed: <i>Estimate the ratio of the area of upstream basin contributing surface water to the wetland to the area of the wetland unit itself.</i> • The area of the basin is less than 10 times the area of unit..... points = 5 <input type="checkbox"/> • The area of the basin is 10 to 100 times the area of the unit..... points = 3 <input checked="" type="checkbox"/> • The area of the basin is more than 100 times the area of the unit points = 0 <input type="checkbox"/> • Entire unit is in the FLATS class points = 5 <input type="checkbox"/>	3
Total for D 3		<i>Add the points in the boxes above</i> 8

D 4	<p>Does the wetland have the <u>opportunity</u> to reduce flooding and erosion?</p> <p>Answer YES if the unit is in a location in the watershed where the flood storage, or reduction in water velocity, it provides helps protect downstream property and aquatic resources from flooding or excessive and/or erosive flows. Answer NO if the water coming into the wetland is controlled by a structure such as flood gate, tide gate, flap valve, reservoir etc. OR you estimate that more than 90% of the water in the wetland is from groundwater in areas where damaging groundwater flooding does not occur. <i>Note which of the following indicators of opportunity apply.</i></p> <p> <input type="checkbox"/> Wetland is in a headwater of a river or stream that has flooding problems. <input checked="" type="checkbox"/> Wetland drains to a river or stream that has flooding problems <input type="checkbox"/> Wetland has no outlet and impounds surface runoff water that might otherwise flow into a river or stream that has flooding problems <input type="checkbox"/> Other _____ </p> <p> <input checked="" type="checkbox"/> YES multiplier is 2 <input type="checkbox"/> NO multiplier is 1 </p>	<p>(see p. 49)</p> <p>Multiplier</p> <p>2</p>
◆	<p>TOTAL – Hydrologic Functions Multiply the score from D3 by D4; then <i>add score to table on p. 1</i></p>	<p><u>16</u></p>

Comments: _____

These questions apply to wetlands of all HGM classes.		Points																
HABITAT FUNCTIONS – Indicators that wetland functions to provide important habitat.		(only 1 score per box)																
H 1	Does the wetland have the potential to provide habitat for many species?																	
H 1.1	<p>Vegetation structure (see P. 72): Check the types of vegetation classes present (as defined by Cowardin) – Size threshold for each class is 1/4 acre or more than 10% of the area if unit is smaller than 2.5 acres.</p> <p><input type="checkbox"/> Aquatic Bed <input checked="" type="checkbox"/> Emergent plants <input checked="" type="checkbox"/> Scrub/shrub (areas where shrubs have > 30% cover) <input checked="" type="checkbox"/> Forested (areas where trees have > 30% cover)</p> <p>If the unit has a forested class check if: <input type="checkbox"/> The forested class has 3 out of 5 strata (canopy, sub-canopy, shrubs, herbaceous, moss/ground-cover) that each cover 20% within the forested polygon. Add the number of vegetation types that qualify. If you have:</p> <table border="0"> <tr> <td>4 structures or more..... points = 4</td> <td><input type="checkbox"/></td> <td>Map of Cowardin vegetation classes</td> <td></td> </tr> <tr> <td>2 structures..... points = 1</td> <td><input type="checkbox"/></td> <td>3 structures..... points = 2</td> <td><input checked="" type="checkbox"/></td> </tr> <tr> <td></td> <td></td> <td>1 structure..... points = 0</td> <td><input type="checkbox"/></td> </tr> </table>	4 structures or more..... points = 4	<input type="checkbox"/>	Map of Cowardin vegetation classes		2 structures..... points = 1	<input type="checkbox"/>	3 structures..... points = 2	<input checked="" type="checkbox"/>			1 structure..... points = 0	<input type="checkbox"/>	<p>Figure <input type="checkbox"/></p> <p style="text-align: right;">2</p>				
4 structures or more..... points = 4	<input type="checkbox"/>	Map of Cowardin vegetation classes																
2 structures..... points = 1	<input type="checkbox"/>	3 structures..... points = 2	<input checked="" type="checkbox"/>															
		1 structure..... points = 0	<input type="checkbox"/>															
H 1.2	<p>Hydroperiods (see p.73): Check the types of water regimes (hydroperiods) present within the wetland. The water regime has to cover more than 10% of the wetland or 1/4 acre to count (see text for descriptions of hydroperiods).</p> <table border="0"> <tr> <td><input type="checkbox"/> Permanently flooded or inundated</td> <td>4 or more types present</td> <td>points = 3</td> <td><input type="checkbox"/></td> </tr> <tr> <td><input checked="" type="checkbox"/> Seasonally flooded or inundated</td> <td>3 or more types present</td> <td>points = 2</td> <td><input type="checkbox"/></td> </tr> <tr> <td><input checked="" type="checkbox"/> Occasionally flooded or inundated</td> <td>2 types present</td> <td>points = 1</td> <td><input checked="" type="checkbox"/></td> </tr> <tr> <td><input checked="" type="checkbox"/> Saturated only</td> <td>1 type present</td> <td>points = 0</td> <td><input type="checkbox"/></td> </tr> </table> <p><input type="checkbox"/> Permanently flowing stream or river in, or adjacent to, the wetland <input type="checkbox"/> Seasonally flowing stream in, or adjacent to, the wetland <input type="checkbox"/> Lake-fringe wetland..... = 2 points <input type="checkbox"/> Freshwater tidal wetland..... = 2 points</p> <p style="text-align: right;">Map of hydroperiods</p>	<input type="checkbox"/> Permanently flooded or inundated	4 or more types present	points = 3	<input type="checkbox"/>	<input checked="" type="checkbox"/> Seasonally flooded or inundated	3 or more types present	points = 2	<input type="checkbox"/>	<input checked="" type="checkbox"/> Occasionally flooded or inundated	2 types present	points = 1	<input checked="" type="checkbox"/>	<input checked="" type="checkbox"/> Saturated only	1 type present	points = 0	<input type="checkbox"/>	<p>Figure <input type="checkbox"/></p> <p style="text-align: right;">1</p>
<input type="checkbox"/> Permanently flooded or inundated	4 or more types present	points = 3	<input type="checkbox"/>															
<input checked="" type="checkbox"/> Seasonally flooded or inundated	3 or more types present	points = 2	<input type="checkbox"/>															
<input checked="" type="checkbox"/> Occasionally flooded or inundated	2 types present	points = 1	<input checked="" type="checkbox"/>															
<input checked="" type="checkbox"/> Saturated only	1 type present	points = 0	<input type="checkbox"/>															
H 1.3	<p>Richness of Plant Species (see p. 75): Count the number of plant species in the wetland that cover at least 10 ft² (different patches of the same species can be combined to meet the size threshold) You do not have to name the species. Do not include Eurasian Milfoil, reed canarygrass, purple loosestrife, Canadian Thistle. If you counted: > 19 species points = 2 <input type="checkbox"/> 5 – 19 species..... points = 1 <input checked="" type="checkbox"/> < 5 species points = 0 <input type="checkbox"/></p> <p>List species below if you want to: _____</p>	<p style="text-align: right;">1</p>																
H 1.4	<p>Interspersion of Habitats (see p. 76): Decided from the diagrams below whether interspersion between Cowardin vegetation (described in H1.1), or the classes and unvegetated areas (can include open water or mudflats) is high, medium, low, or none.</p> <div style="text-align: center;"> <p>None = 0 points Low = 1 point Moderate = 2 points</p> <p>High = 3 points [riparian braided channels]</p> </div> <p>Note: If you have 4 or more classes or 3 vegetation classes and open water, the rating is always “high”. Use map of Cowardin classes.</p>	<p>Figure <input type="checkbox"/></p> <p style="text-align: right;">2</p>																
H 1.5	<p>Special Habitat Features (see p. 77): Check the habitat features that are present in the wetland. The number of checks is the number of points you put into the next column.</p> <p><input checked="" type="checkbox"/> Large, downed, woody debris within the wetland (> 4 in. diameter and 6 ft. long) <input checked="" type="checkbox"/> Standing snags (diameter at the bottom > 4 inches) in the wetland <input type="checkbox"/> Undercut banks are present for at least 6.6 ft. (2m) and/or overhanging vegetation extends at least 3.3 ft. (1m) over a stream (or ditch) in, or contiguous with the unit, for at least 33 ft. (10m) <input type="checkbox"/> Stable steep banks of fine material that might be used by beaver or muskrat for denning (> 30 degree slope) OR signs of recent beaver activity are present (cut shrubs or trees that have not yet turned grey/brown) <input type="checkbox"/> At least 1/4 acre of thin-stemmed persistent vegetation or woody branches are present in areas that are permanently or seasonally inundated (structures for egg-laying by amphibians) <input type="checkbox"/> Invasive plants cover less than 25% of the wetland area in each stratum of plants NOTE: The 20% stated in early printings of the manual on page 78 is an error.</p>	<p style="text-align: right;">2</p>																
H 1 TOTAL Score – potential for providing habitat		8																

Add the points in the column above

H 2	Does the wetland have the <u>opportunity</u> to provide habitat for many species?	(only 1 score per box)
	<p>H 2.1 <u>Buffers</u> (see P. 80): Choose the description that best represents condition of buffer of wetland unit. The highest scoring criterion that applies to the wetland is to be used in the rating. See text for definition of "undisturbed".</p> <p><input type="checkbox"/> 100m (330 ft) of relatively undisturbed vegetated areas, rocky areas, or open water > 95% of circumference. No structures are within the undisturbed part of buffer (relatively undisturbed also means no grazing, no landscaping, no daily human use)..... points = 5</p> <p><input type="checkbox"/> 100m (330 ft) of relatively undisturbed vegetated areas, rocky areas, or open water > 50% circumference points = 4</p> <p><input type="checkbox"/> 50m (170 ft) of relatively undisturbed vegetated areas, rocky areas, or open water > 95% circumference points = 4</p> <p><input type="checkbox"/> 100m (330 ft) of relatively undisturbed vegetated areas, rocky areas, or open water > 25% circumference points = 3</p> <p><input type="checkbox"/> 50m (170 ft) of relatively undisturbed vegetated areas, rocky areas, or open water for > 50% circumference points = 3</p> <p>If buffer does not meet any of the criteria above:</p> <p><input type="checkbox"/> No paved areas (except paved trails) or buildings within 25m (80 ft) of wetland > 95% circumference. Light to moderate grazing or lawns are OK points = 2</p> <p><input type="checkbox"/> No paved areas of buildings within 50m of wetland for > 50% circumference. Light to moderate grazing or lawns are OK points = 2</p> <p><input type="checkbox"/> Heavy grazing in buffer points = 1</p> <p><input type="checkbox"/> Vegetated buffers are < 2m wide (6.6 ft) for more than 95% circumference (e.g. tilled fields, paving, basalt bedrock extend to edge of wetland) points = 0</p> <p><input checked="" type="checkbox"/> Buffer does not meet any of the criteria above points = 1</p> <p style="text-align: right;">Arial photo showing buffers</p>	<p>Figure <input type="checkbox"/></p> <p style="text-align: right;">1</p>
	<p>H 2.2 <u>Corridors and Connections</u> (see p. 81)</p> <p>H 2.2.1 Is the wetland part of a relatively undisturbed and unbroken vegetated corridor (either riparian or upland) that is at least 150 ft. wide, has at least a 30% cover of shrubs, forest or native undisturbed prairie, that connects to estuaries, other wetlands or undisturbed uplands that are at least 250 acres in size? (<i>Dams in riparian corridors, heavily used gravel roads, paved roads, are considered breaks in the corridor.</i>)</p> <p style="padding-left: 40px;"><input type="checkbox"/> YES = 4 points (go to H 2.3) <input checked="" type="checkbox"/> NO = go to H 2.2.2</p> <p>H. 2.2.2 Is the wetland part of a relatively undisturbed and unbroken vegetated corridor (either riparian or upland) that is at least 50 ft. wide, has at least 30% cover of shrubs or forest, and connects to estuaries, other wetlands or undisturbed uplands that are at least 25 acres in size? OR a Lake-fringe wetland, if it does not have an undisturbed corridor as in the question above?</p> <p style="padding-left: 40px;"><input type="checkbox"/> YES = 2 points (go to H 2.3) <input checked="" type="checkbox"/> NO = go to H 2.2.3</p> <p>H. 2.2.3 Is the wetland:</p> <ul style="list-style-type: none"> • Within 5 mi (8km) of a brackish or salt water estuary OR • Within 3 miles of a large field or pasture (> 40 acres) OR • Within 1 mile of a lake greater than 20 acres? <p style="text-align: right; padding-right: 40px;"><input type="checkbox"/> YES = 1 point <input checked="" type="checkbox"/> NO = 0 points</p>	<p style="text-align: right;">0</p>

Comments: _____

	<p>H 2.3 <u>Near or adjacent to other priority habitats listed by WDFW</u> (see p. 82): <i>(see new and complete descriptions of WDFW priority habitats, and the counties in which they can be found, in the PHS report http://wdfw.wa.gov/hab/phslist.htm)</i> Which of the following priority habitats are within 330 ft. (100m) of the wetland unit? NOTE: <i>the connections do not have to be relatively undisturbed.</i></p> <p><input type="checkbox"/> Aspen Stands: Pure or mixed stands of aspen greater than 0.4 ha (1 acre).</p> <p><input type="checkbox"/> Biodiversity Areas and Corridors: Areas of habitat that are relatively important to various species of native fish and wildlife <i>(full descriptions in WDFW PHS report p. 152).</i></p> <p><input type="checkbox"/> Herbaceous Balds: Variable size patches of grass and forbs on shallow soils over bedrock.</p> <p><input type="checkbox"/> Old-growth/Mature forests: (Old-growth west of Cascade crest) Stands of at least 2 tree species, forming a multi-layered canopy with occasional small openings; with at least 20 trees/ha (8 trees/acre) > 81 cm (32 in) dbh or > 200 years of age. (Mature forests) Stands with average diameters exceeding 53 cm (21 in) dbh; crown cover may be less than 100%; decay, decadence, numbers of snags, and quantity of large downed material is generally less than that found in old-growth; 80 - 200 years old west of the Cascade crest.</p> <p><input type="checkbox"/> Oregon white Oak: Woodlands Stands of pure oak or oak/conifer associations where canopy coverage of the oak component is important <i>(full descriptions in WDFW PHS report p. 158).</i></p> <p><input type="checkbox"/> Riparian: The area adjacent to aquatic systems with flowing water that contains elements of both aquatic and terrestrial ecosystems which mutually influence each other.</p> <p><input type="checkbox"/> Westside Prairies: Herbaceous, non-forested plant communities that can either take the form of a dry prairie or a wet prairie <i>(full descriptions in WDFW PHS report p. 161).</i></p> <p><input type="checkbox"/> Instream: The combination of physical, biological, and chemical processes and conditions that interact to provide functional life history requirements for instream fish and wildlife resources.</p> <p><input type="checkbox"/> Nearshore: Relatively undisturbed nearshore habitats. These include Coastal Nearshore, Open Coast Nearshore, and Puget Sound Nearshore. <i>(full descriptions of habitats and the definition of relatively undisturbed are in WDFW report: pp. 167-169 and glossary in Appendix A).</i></p> <p><input type="checkbox"/> Caves: A naturally occurring cavity, recess, void, or system of interconnected passages under the earth in soils, rock, ice, or other geological formations and is large enough to contain a human.</p> <p><input type="checkbox"/> Cliffs: Greater than 7.6 m (25 ft) high and occurring below 5000 ft.</p> <p><input type="checkbox"/> Talus: Homogenous areas of rock rubble ranging in average size 0.15 - 2.0 m (0.5 - 6.5 ft), composed of basalt, andesite, and/or sedimentary rock, including riprap slides and mine tailings. May be associated with cliffs.</p> <p><input type="checkbox"/> Snags and Logs: Trees are considered snags if they are dead or dying and exhibit sufficient decay characteristics to enable cavity excavation/use by wildlife. Priority snags have a diameter at breast height of > 51 cm (20 in) in western Washington and are > 2 m (6.5 ft) in height. Priority logs are > 30 cm (12 in) in diameter at the largest end, and > 6 m (20 ft) long.</p> <p style="text-align: right;">If wetland has 3 or more priority habitats = 4 points If wetland has 2 priority habitats = 3 points If wetland has 1 priority habitat = 1 point No habitats = 0 points</p> <p>Note: All vegetated wetlands are by definition a priority habitat but are not included in this list. Nearby wetlands are addressed in question H 2.4)</p>	0
	<p>H 2.4 <u>Wetland Landscape:</u> <i>Choose the one description of the landscape around the wetland that best fits (see p. 84)</i></p> <ul style="list-style-type: none"> • There are at least 3 other wetlands within 1/2 mile, and the connections between them are relatively undisturbed (light grazing between wetlands OK, as is lake shore with some boating, but connections should NOT be bisected by paved roads, fill, fields, or other development.... points = 5 <input type="checkbox"/> • The wetland is Lake-fringe on a lake with little disturbance and there are 3 other lake-fringe wetlands within 1/2 mile points = 5 <input type="checkbox"/> • There are at least 3 other wetlands within 1/2 mile, BUT the connections between them are disturbed. points = 3 <input checked="" type="checkbox"/> • The wetland fringe on a lake with disturbance and there are 3 other lake-fringe wetlands within 1/2 mile points = 3 <input type="checkbox"/> • There is at least 1 wetland within 1/2 mile points = 2 <input type="checkbox"/> • There are no wetlands within 1/2 mile..... points = 0 <input type="checkbox"/> 	3
	<p>H 2 TOTAL Score – opportunity for providing habitat <i>Add the scores from H2.1, H2.2, H2.3, H2.4</i></p>	4
	<p><i>TOTAL for H 1 from page 8</i></p>	8
◆	<p>Total Score for Habitat Functions <i>Add the points for H 1 and H 2; then record the result on p. 1</i></p>	12

Comments: _____

CATEGORIZATION BASED ON SPECIAL CHARACTERISTICS

Please determine if the wetland meets the attributes described below and circle the appropriate answers and Category.

Wetland Type – Check off any criteria that apply to the wetland. Circle the Category when the appropriate criteria are met.	
SC1	<p>Estuarine wetlands? (see p.86)</p> <p>Does the wetland unit meet the following criteria for Estuarine wetlands?</p> <p><input type="checkbox"/> The dominant water regime is tidal, <input type="checkbox"/> Vegetated, and <input type="checkbox"/> With a salinity greater than 0.5 ppt.</p> <p style="text-align: center;"><input type="checkbox"/> YES = Go to SC 1.1 <input checked="" type="checkbox"/> NO</p>
	<p>SC 1.1 Is the wetland unit within a National Wildlife Refuge, National Park, National Estuary Reserve, Natural Area Preserve, State Park or Educational, Environmental, or Scientific Reserve designated under WAC 332-30-151? <input type="checkbox"/> YES = Category I <input type="checkbox"/> NO = go to SC 1.2</p>
	<p>SC 1.2 Is the wetland at least 1 acre in size and meets at least two of the following conditions?</p> <p style="text-align: center;"><input type="checkbox"/> YES = Category I <input type="checkbox"/> NO = Category II</p> <p><input type="checkbox"/> The wetland is relatively undisturbed (has no diking, ditching, filling, cultivation, grazing, and has less than 10% cover of non-native plant species. If the non-native <i>Spartina</i> spp. are only species that cover more than 10% of the wetland, then the wetland should be given a dual rating (I/II). The area of <i>Spartina</i> would be rated a Category II while the relatively undisturbed upper marsh with native species would be a Category I. Do not, however, exclude the area of <i>Spartina</i> in determining the size threshold of 1 acre.</p> <p><input type="checkbox"/> At least 3/4 of the landward edge of the wetland has a 100 ft. buffer of shrub, forest, or un-grazed or un-mowed grassland</p> <p><input type="checkbox"/> The wetland has at least 2 of the following features: tidal channels, depressions with open water, or contiguous freshwater wetlands.</p>
SC2	<p>Natural Heritage Wetlands (see p. 87)</p> <p>Natural Heritage wetlands have been identified by the Washington Natural Heritage Program/DNR as either high quality undisturbed wetlands or wetlands that support state Threatened, Endangered, or Sensitive plant species.</p> <p>SC 2.1 Is the wetland being rated in a Section/Township/Range that contains a natural heritage wetland? (This question is used to screen out most sites before you need to contact WNHP/DNR.)</p> <p style="text-align: center;"><input type="checkbox"/> S/T/R information from Appendix D <input type="checkbox"/> or accessed from WNHP/DNR web site <input type="checkbox"/> YES Contact WNHP/DNR (see p. 79) and go to SC 2.2 <input checked="" type="checkbox"/> NO</p> <p>SC 2.2 Has DNR identified the wetland as a high quality undisturbed wetland or as a site with state threatened or endangered plant species?</p> <p style="text-align: center;"><input type="checkbox"/> YES = Category 1 <input checked="" type="checkbox"/> NO not a Heritage Wetland</p>
SC3	<p>Bogs (see p. 87)</p> <p>Does the wetland (or any part of the unit) meet both the criteria for soils and vegetation in bogs? Use the key below to identify if the wetland is a bog. If you answer yes you will still need to rate the wetland based on its function.</p> <ol style="list-style-type: none"> Does the unit have organic soil horizons (i.e. layers of organic soil), either peats or mucks, that compose 16 inches or more of the first 32 inches of soil profile? (See Appendix B for a field key to identify organic soils)? <input type="checkbox"/> YES = go to question 3 <input checked="" type="checkbox"/> NO = go to question 2 Does the wetland have organic soils, either peats or mucks that are less than 16 inches deep over bedrock, or an impermeable hardpan such as clay or volcanic ash, or that are floating on a lake or pond? <input type="checkbox"/> YES = go to question 3 <input checked="" type="checkbox"/> NO = is not a bog for purpose of rating Does the unit have more than 70% cover of mosses at ground level, AND other plants, if present, consist of the “bog” species listed in Table 3 as a significant component of the vegetation (more than 30% of the total shrub and herbaceous cover consists of species in Table 3)? <p style="text-align: center;"><input type="checkbox"/> YES = Is a bog for purpose of rating <input checked="" type="checkbox"/> NO = go to question 4</p> <p>NOTE: If you are uncertain about the extent of mosses in the understory you may substitute that criterion by measuring the pH of the water that seeps into a hole dug at least 16” deep. If the pH is less than 5.0 and the “bog” plant species in Table 3 are present, the wetland is a bog.</p> <ol style="list-style-type: none"> Is the unit forested (> 30% cover) with sitka spruce, subalpine fir, western red cedar, western hemlock, lodgepole pine, quaking aspen, Englemann’s spruce, or western white pine. WITH any of the species (or combination of species) on the bog species plant list in Table 3 as a significant component of the ground cover (> 30% coverage of the total shrub/herbaceous cover)? <p style="text-align: center;"><input type="checkbox"/> YES = Category I <input checked="" type="checkbox"/> NO = Is not a bog for purpose of rating</p>
	<p>Cat. I <input type="checkbox"/></p> <p>Cat. II <input type="checkbox"/></p> <p>Dual Rating I/II <input type="checkbox"/></p> <p>Cat I <input type="checkbox"/></p> <p>Cat. I <input type="checkbox"/></p>

SC4	<p>Forested Wetlands (see p. 90)</p> <p>Does the wetland have at least 1 acre of forest that meet one of these criteria for the Department of Fish and Wildlife’s forests as priority habitats? <i>If you answer yes you will still need to rate the wetland based on its function.</i></p> <p><input type="checkbox"/> Old-growth forests: (west of Cascade Crest) Stands of at least two three species forming a multi-layered canopy with occasional small openings; with at least 8 trees/acre (20 trees/hectare) that are at least 200 years of age OR have a diameter at breast height (dbh) of 32 inches (81 cm or more). NOTE: The criterion for dbh is based on measurements for upland forests. Two-hundred year old trees in wetlands will often have a smaller dbh because their growth rates are often slower. The DFW criterion is and “OR” so old-growth forests do not necessarily have to have trees of this diameter.</p> <p><input type="checkbox"/> Mature forests: (west of the Cascade Crest) Stands where the largest trees are 80 – 200 years old OR have an average diameters (dbh) exceeding 21 inches (53 cm); crown cover may be less than 100%; decay, decadence, numbers of snags, and quantity of large downed material is generally less than that found in old-growth.</p> <p><input type="checkbox"/> YES = Category I <input checked="" type="checkbox"/> NO = not a forested wetland with special characteristics</p>	<p>Cat. I <input type="checkbox"/></p>
SC5	<p>Wetlands in Coastal Lagoons (see p. 91)</p> <p>Does the wetland meet all of the following criteria of a wetland in a coastal lagoon?</p> <p><input type="checkbox"/> The wetland lies in a depression adjacent to marine waters that is wholly or partially separated from marine waters by sandbanks, gravel banks, shingle, or, less frequently, rocks.</p> <p><input type="checkbox"/> The lagoon in which the wetland is located contains surface water that is saline or brackish (> 0.5 ppt) during most of the year in at least a portion of the lagoon (<i>needs to be measured near the bottom.</i>)</p> <p><input type="checkbox"/> YES = Go to SC 5.1 <input checked="" type="checkbox"/> NO not a wetland in a coastal lagoon</p> <p>SC 5.1 Does the wetland meet all of the following three conditions?</p> <p><input type="checkbox"/> The wetland is relatively undisturbed (has no diking, ditching, filling, cultivation, grazing) and has less than 20% cover of invasive plant species (see list of invasive species on p. 74).</p> <p><input type="checkbox"/> At least 3/4 of the landward edge of the wetland has a 100 ft. buffer of shrub, forest, or un-grazed or un-mowed grassland.</p> <p><input type="checkbox"/> The wetland is larger than 1/10 acre (4350 square ft.)</p> <p><input type="checkbox"/> YES = Category I <input type="checkbox"/> NO = Category II</p>	<p style="background-color: #cccccc;"> </p> <p>Cat. I <input type="checkbox"/></p> <p>Cat. II <input type="checkbox"/></p>
SC6	<p>Interdunal Wetlands (see p. 93)</p> <p>Is the wetland west of the 1889 line (also called the Western Boundary of Upland Ownership or WBUO)?</p> <p><input type="checkbox"/> YES = Go to SC 6.1 <input checked="" type="checkbox"/> NO not an interdunal wetland for rating</p> <p><i>If you answer yes you will still need to rate the wetland based on its functions.</i></p> <p>In practical terms that means the following geographic areas:</p> <ul style="list-style-type: none"> • Long Beach Peninsula -- lands west of SR 103 • Grayland-Westport -- lands west of SR 105 • Ocean Shores-Copalis – lands west of SR 115 and SR 109 <p>SC 6.1 Is the wetland one acre or larger, or is it in a mosaic of wetlands that is one acre or larger?</p> <p><input type="checkbox"/> YES = Category II <input type="checkbox"/> NO = go to SC 6.2</p> <p>SC 6.2 Is the wetland between 0.1 and 1 acre, or is it in a mosaic of wetlands that is between 0.1 and 1 acre?</p> <p><input type="checkbox"/> YES = Category III</p>	<p>Cat. II <input type="checkbox"/></p> <p>Cat. III <input type="checkbox"/></p>
◆	<p>Category of wetland based on Special Characteristics</p> <p><i>Choose the “highest” rating if wetland falls into several categories, and record on p. 1.</i></p> <p>If you answered NO for all types enter “Not Applicable” on p. 1</p>	<p>NA</p>

Comments:

WETLAND RATING FORM – WESTERN WASHINGTON
Version 2 – Updated July 2006 to increase accuracy and reproducibility among users
Updated Oct. 2008 with the new WDFW definitions for priority habitats

Name of wetland (if known): Egyptcr/Ncmg

Date of site visit: February 14, 2013

Rated by: C. Douglas & J. Pursley Trained by Ecology? Yes No

Date of training: May 2007

SEC: 29 TOWNSHP: 24N RNGE: 5E

Is S/T/R in Appendix D? Yes No

Map of wetland unit: Figure _____ Estimated size _____

SUMMARY OF RATING

Category based on FUNCTIONS provided by wetland: I II III IV

Category I =	Score > 70
Category II =	Score 51 - 69
Category III =	Score 30 – 50
Category IV =	Score < 30

Score for Water Quality Functions

10

Score for Hydrologic Functions

20

Score for Habitat Functions

11

TOTAL Score for Functions

41

Category based on SPECIAL CHARACTERISTICS of Wetland I II Does not apply

Final Category (choose the “highest” category from above”)

III

Summary of basic information about the wetland unit.

Wetland Unit has Special Characteristics		Wetland HGM Class used for Rating	
Estuarine	<input type="checkbox"/>	Depressional	<input checked="" type="checkbox"/>
Natural Heritage Wetland	<input type="checkbox"/>	Riverine	<input type="checkbox"/>
Bog	<input type="checkbox"/>	Lake-fringe	<input type="checkbox"/>
Mature Forest	<input type="checkbox"/>	Slope	<input type="checkbox"/>
Old Growth Forest	<input type="checkbox"/>	Flats	<input type="checkbox"/>
Coastal Lagoon	<input type="checkbox"/>	Freshwater Tidal	<input type="checkbox"/>
Interdunal	<input type="checkbox"/>		<input type="checkbox"/>
None of the above	<input checked="" type="checkbox"/>	Check if unit has multiple HGM classes present	<input type="checkbox"/>

Does the wetland being rated meet any of the criteria below? If you answer YES to any of the questions below you will need to protect the wetland according to the regulations regarding the special characteristics found in the wetland.

Check List for Wetlands that Need Additional Protection (in addition to the protection recommended for its category)	YES	NO
SP1. <i>Has the wetland unit been documented as a habitat for any Federally listed Threatened or Endangered animal or plant species (T/E species)?</i> For the purposes of this rating system, “documented” means the wetland is on the appropriate state or federal database.	<input type="checkbox"/>	<input checked="" type="checkbox"/>
SP2. <i>Has the wetland unit been documented as habitat for any State listed Threatened or Endangered animal species?</i> For the purposes of this rating system, “documented” means the wetland is on the appropriate state database. Note: Wetlands with State listed plant species are categorized as Category 1 Natural Heritage Wetlands (see p. 19 of data form).	<input type="checkbox"/>	<input checked="" type="checkbox"/>
SP3. <i>Does the wetland unit contain individuals of Priority species listed by the WDFW for the state?</i>	<input type="checkbox"/>	<input checked="" type="checkbox"/>
SP4. <i>Does the wetland unit have a local significance in addition to its functions?</i> For example, the wetland has been identified in the Shoreline Master Program, the Critical Areas Ordinance, or in a local management plan as having special significance.	<input type="checkbox"/>	<input checked="" type="checkbox"/>

To complete the next part of the data sheet you will need to determine the Hydrogeomorphic Class of the wetland being rated.

The hydrogeomorphic classification groups wetlands in to those that function in similar ways. This simplifies the questions needed to answer how well the wetland functions. The Hydrogeomorphic Class of a wetland can be determined using the key below. See p. 24 for more detailed instructions on classifying wetlands.

Classification of Vegetated Wetlands for Western Washington

If the hydrologic criteria listed in each question do not apply to the entire unit being rated, you probably have a unit with multiple HGM classes. In this case, identify which hydrologic criteria in questions 1-7 apply, and go to Question 8.

1. Are the water levels in the entire unit usually controlled by tides (i.e. except during floods)?
 NO – go to 2 YES – the wetland class is **Tidal Fringe**
 If yes, is the salinity of the water during periods of annual low flow below 0.5 ppt (parts per thousand)?
 YES – **Freshwater Tidal Fringe** NO – **Saltwater Tidal Fringe (Estuarine)**
*If your wetland can be classified as a Freshwater Tidal Fringe use the forms for **Riverine** wetlands. If it is a Saltwater Tidal Fringe it is rated as an **Estuarine** wetland. Wetlands that were call estuarine in the first and second editions of the rating system are called Salt Water Tidal Fringe in the Hydrogeomorphic Classification. Estuarine wetlands were categorized separately in the earlier editions, and this separation is being kept in this revision. To maintain consistency between editions, the term “Estuarine” wetland is kept. Please note, however, that the characteristics that define Category I and II estuarine wetlands have changed (see p. _____).*
-
2. The entire wetland unit is flat and precipitation is only source (>90%) of water to it. Groundwater and surface water runoff are NOT sources of water to the unit.
 NO – go to 3 YES – The wetland class is **Flats**
 If your wetland can be classified as a “Flats” wetland, use the form for **Depressional** wetlands.
-
3. Does the entire wetland meet both of the following criteria?
 The vegetated part of the wetland is on the shores of a body of permanent open water (without any vegetation on the surface) where at least 20 acres (8ha) in size;
 At least 30% of the open water area is deeper than 6.6 (2 m)?
 NO – go to 4 YES – The wetland class is **Lake-fringe (Lacustrine Fringe)**
-
4. Does the entire wetland meet all of the following criteria?
 The wetland is on a slope (*slope can be very gradual*).
 The water flows through the wetland in one direction (unidirectional) and usually comes from seeps. It may flow subsurface, as sheetflow, or in a swale without distinct banks.
 The water leaves the wetland **without being impounded**?
 NOTE: *Surface water does not pond in these types of wetlands except occasionally in very small and shallow depressions or behind hummocks (depressions are usually <3 ft diameter and less than 1 foot deep).*
 NO – go to 5 YES – The wetland class is **Slope**
-
5. Does the entire wetland meet all of the following criteria?
 The unit is in a valley or stream channel where it gets inundated by overbank flooding from that stream or river.
 The overbank flooding occurs at least once every two years.
 NOTE: *The riverine unit can contain depressions that are filled with water when the river is not flooding..*
 NO – go to 6 YES – The wetland class is **Riverine**
-
6. Is the entire wetland unit in a topographic depression in which water ponds, or is saturated to the surface, at some time of the year. This means that any outlet, if present is higher than the interior of the wetland.
 NO – go to 7 YES – The wetland class is **Depressional**
-
7. Is the entire wetland located in a very flat area with no obvious depression and no overbank flooding. The unit does not pond surface water more than a few inches. The unit seems to be maintained by high groundwater in the area. The wetland may be ditched, but has no obvious natural outlet.
 No – go to 8 YES – The wetland class is **Depressional**
-
8. Your wetland unit seems to be difficult to classify and probably contains several different HGM classes. For example, seeps at the base of a slope may grade into a riverine floodplain, or a small stream within a depressional wetland has a zone of flooding along its sides. GO BACK AND IDENTIFY WHICH OF THE HYDROLOGIC REGIMES DESCRIBED IN QUESTIONS 1-7 APPLY TO DIFFERENT AREAS IN THE UNIT (make a rough sketch to help you decide). Use the following table to identify the appropriate class to use for the rating system if you have several HGM classes present within your wetland. NOTE: Use this table only if the class that is recommended in the second column represents 10% or more of the total area of the wetland unit being rated. If the area of the class listed in column 2 is less than 10% of the unit, classify the wetland using the class that represents more than 90% of the total area.

HGM Classes within the wetland unit being rated	HGM Class to Use in Rating
Slope + Riverine	Riverine
Slope + Depressional	Depressional
Slope + Lake-fringe	Lake-fringe
Depressional + Riverine along stream within boundary	Depressional
Depressional + Lake-fringe	Depressional
Salt Water Tidal Fringe and any other class of freshwater wetland	Treat as ESTUARINE under wetlands with special characteristics

If you are unable still to determine which of the above criteria apply to your wetland, or you have more than 2 HGM classes within a wetland boundary, classify the wetland as **Depressional** for the rating.

D Depressional and Flat Wetlands		Points
WATER QUALITY FUNCTIONS – Indicators that wetland functions to improve water quality.		(only 1 score per box) (see p.38)
D 1	Does the wetland have the <u>potential</u> to improve water quality?	
D 1.1	Characteristics of surface water flows out of the wetland: • Unit is a depression with no surface water leaving it (no outlet) points = 3 <input type="checkbox"/> • Unit has an intermittently flowing, OR highly constricted, permanently flowing outlet ... points = 2 <input checked="" type="checkbox"/> • Unit has an unconstricted, or slightly constricted, surface outlet (<i>permanently flowing</i>) .. points = 1 <input type="checkbox"/> • Unit is a “flat” depression (Q.7 on key), or in the Flats class, with permanent surface outflow and no obvious natural outlet and/or outlet is a man-made ditch..... points = 1 <input type="checkbox"/> <i>(If ditch is not permanently flowing treat unit as “intermittently flowing”)</i> Provide photo or drawing	Figure <input type="checkbox"/> 2
D 1.2	The soil 2 inches below the surface (or duff layer) is clay or organic (<i>use NRCS definitions</i>) YES points = 4 NO points = 0	0
D 1.3	Characteristics of persistent vegetation (emergent, shrub, and/or forest Cowardin class): • Wetland has persistent, ungrazed vegetation > = 95% of area points = 5 <input type="checkbox"/> • Wetland has persistent, ungrazed vegetation > = 1/2 of area points = 3 <input checked="" type="checkbox"/> • Wetland has persistent, ungrazed vegetation > = 1/10 of area points = 1 <input type="checkbox"/> • Wetland has persistent, ungrazed vegetation < 1/10 of area points = 0 <input type="checkbox"/> Map of Cowardin vegetation classes	Figure <input type="checkbox"/> 3
D 1.4	Characteristics of seasonal ponding or inundation: <i>This is the area of the wetland that is ponded for at least 2 months, but dries out sometime during the year. Do not count the area that is permanently ponded. Estimate area as the average condition 5 out of 10 years.</i> • Area seasonally ponded is > 1/2 total area of wetland points = 4 <input type="checkbox"/> • Area seasonally ponded is > 1/4 total area of wetland points = 2 <input type="checkbox"/> • Area seasonally ponded is < 1/4 total area of wetland points = 0 <input checked="" type="checkbox"/> Map of Hydroperiods	Figure <input type="checkbox"/> 0
Total for D 1		<i>Add the points in the boxes above</i> 5
D 2	Does the wetland have the <u>opportunity</u> to improve water quality?	(see p. 44)
Answer YES if you know or believe there are pollutants in groundwater or surface water coming into the wetland that would otherwise reduce water quality in streams, lakes or groundwater downgradient from the wetland? <i>Note which of the following conditions provide the sources of pollutants. A unit may have pollutants coming from several sources, but any single source would qualify as opportunity.</i> <input type="checkbox"/> Grazing in the wetland or within 150 ft <input checked="" type="checkbox"/> Untreated stormwater discharges to wetland <input type="checkbox"/> Tilled fields or orchards within 150 ft. of wetland <input type="checkbox"/> A stream or culvert discharges into wetland that drains developed areas, residential areas, farmed fields, roads, or clear-cut logging <input checked="" type="checkbox"/> Residential, urban areas, golf courses are within 150 ft. of wetland <input type="checkbox"/> Wetland is fed by groundwater high in phosphorus or nitrogen <input type="checkbox"/> Other _____		Multiplier 2
<input checked="" type="checkbox"/> YES multiplier is 2 <input type="checkbox"/> NO multiplier is 1		
◆ TOTAL – Water Quality Functions		Multiply the score from D1 by D2; then add score to table on p. 1
		10
HYDROLOGIC FUNCTIONS – Indicators that wetland unit functions to reduce flooding and stream degradation.		
D 3	Does the wetland have the <u>potential</u> to reduce flooding and erosion?	(see p.46)
D 3.1	Characteristics of surface water flows out of the wetland unit • Unit is a depression with no surface water leaving it (no outlet) points = 4 <input type="checkbox"/> • Unit has an intermittently flowing, OR highly constricted permanently flowing outlet points = 2 <input checked="" type="checkbox"/> • Unit is a “flat” depression (Q.7 on key) or in the Flats class, with permanent surface outflow and no obvious natural outlet and/or outlet is a man-made ditch..... points = 1 <input type="checkbox"/> <i>(If ditch is not permanently flowing treat unit as “intermittently flowing”)</i> • Unit has an unconstricted, or slightly constricted, surface outlet (<i>permanently flowing</i>) points = 0	2
D 3.2	Depth of storage during wet periods. <i>Estimate the height of ponding above the bottom of the outlet. For units with no outlet measure from the surface of permanent water or deepest part (if dry).</i> • Marks of ponding are 3 ft. or more above the surface or bottom of the outlet points = 7 <input type="checkbox"/> • The wetland is a “headwater” wetland..... points = 5 <input type="checkbox"/> • Marks of ponding between 2 ft. to < 3 ft. from surface or bottom of outlet points = 5 <input type="checkbox"/> • Marks are at least 0.5 ft. to < 2 ft. from surface or bottom of outlet points = 3 <input checked="" type="checkbox"/> • Wetland is flat (yes to Q.2 or Q.7 on key) but has small depressions on the surface that trap water . points = 1 <input type="checkbox"/> • Marks of ponding less than 0.5 ft points = 0 <input type="checkbox"/>	3
D 3.3	Contribution of wetland unit to storage in the watershed: <i>Estimate the ratio of the area of upstream basin contributing surface water to the wetland to the area of the wetland unit itself.</i> • The area of the basin is less than 10 times the area of unit..... points = 5 <input checked="" type="checkbox"/> • The area of the basin is 10 to 100 times the area of the unit..... points = 3 <input type="checkbox"/> • The area of the basin is more than 100 times the area of the unit points = 0 <input type="checkbox"/> • Entire unit is in the FLATS class points = 5 <input type="checkbox"/>	5
Total for D 3		<i>Add the points in the boxes above</i> 10

H 2	Does the wetland have the <u>opportunity</u> to provide habitat for many species?	(only 1 score per box)
	<p>H 2.1 <u>Buffers</u> (see P. 80): Choose the description that best represents condition of buffer of wetland unit. The highest scoring criterion that applies to the wetland is to be used in the rating. See text for definition of "undisturbed".</p> <p><input type="checkbox"/> 100m (330 ft) of relatively undisturbed vegetated areas, rocky areas, or open water > 95% of circumference. No structures are within the undisturbed part of buffer (relatively undisturbed also means no grazing, no landscaping, no daily human use)..... points = 5</p> <p><input type="checkbox"/> 100m (330 ft) of relatively undisturbed vegetated areas, rocky areas, or open water > 50% circumference points = 4</p> <p><input type="checkbox"/> 50m (170 ft) of relatively undisturbed vegetated areas, rocky areas, or open water > 95% circumference points = 4</p> <p><input type="checkbox"/> 100m (330 ft) of relatively undisturbed vegetated areas, rocky areas, or open water > 25% circumference points = 3</p> <p><input type="checkbox"/> 50m (170 ft) of relatively undisturbed vegetated areas, rocky areas, or open water for > 50% circumference points = 3</p> <p>If buffer does not meet any of the criteria above:</p> <p><input type="checkbox"/> No paved areas (except paved trails) or buildings within 25m (80 ft) of wetland > 95% circumference. Light to moderate grazing or lawns are OK points = 2</p> <p><input type="checkbox"/> No paved areas of buildings within 50m of wetland for > 50% circumference. Light to moderate grazing or lawns are OK points = 2</p> <p><input type="checkbox"/> Heavy grazing in buffer points = 1</p> <p><input type="checkbox"/> Vegetated buffers are < 2m wide (6.6 ft) for more than 95% circumference (e.g. tilled fields, paving, basalt bedrock extend to edge of wetland) points = 0</p> <p><input checked="" type="checkbox"/> Buffer does not meet any of the criteria above points = 1</p> <p style="text-align: right;">Arial photo showing buffers</p>	<p>Figure <input type="checkbox"/></p> <p style="text-align: right;">1</p>
	<p>H 2.2 <u>Corridors and Connections</u> (see p. 81)</p> <p>H 2.2.1 Is the wetland part of a relatively undisturbed and unbroken vegetated corridor (either riparian or upland) that is at least 150 ft. wide, has at least a 30% cover of shrubs, forest or native undisturbed prairie, that connects to estuaries, other wetlands or undisturbed uplands that are at least 250 acres in size? (<i>Dams in riparian corridors, heavily used gravel roads, paved roads, are considered breaks in the corridor.</i>)</p> <p style="text-align: center;"><input type="checkbox"/> YES = 4 points (go to H 2.3) <input checked="" type="checkbox"/> NO = go to H 2.2.2</p> <p>H. 2.2.2 Is the wetland part of a relatively undisturbed and unbroken vegetated corridor (either riparian or upland) that is at least 50 ft. wide, has at least 30% cover of shrubs or forest, and connects to estuaries, other wetlands or undisturbed uplands that are at least 25 acres in size? OR a Lake-fringe wetland, if it does not have an undisturbed corridor as in the question above?</p> <p style="text-align: center;"><input type="checkbox"/> YES = 2 points (go to H 2.3) <input checked="" type="checkbox"/> NO = go to H 2.2.3</p> <p>H. 2.2.3 Is the wetland:</p> <ul style="list-style-type: none"> • Within 5 mi (8km) of a brackish or salt water estuary OR • Within 3 miles of a large field or pasture (> 40 acres) OR • Within 1 mile of a lake greater than 20 acres? <p style="text-align: right;"><input type="checkbox"/> YES = 1 point <input checked="" type="checkbox"/> NO = 0 points</p>	<p style="text-align: right;">0</p>

Comments: _____

	<p>H 2.3 <u>Near or adjacent to other priority habitats listed by WDFW</u> (see p. 82): <i>(see new and complete descriptions of WDFW priority habitats, and the counties in which they can be found, in the PHS report http://wdfw.wa.gov/hab/phslist.htm)</i> Which of the following priority habitats are within 330 ft. (100m) of the wetland unit? NOTE: <i>the connections do not have to be relatively undisturbed.</i></p> <p><input type="checkbox"/> Aspen Stands: Pure or mixed stands of aspen greater than 0.4 ha (1 acre).</p> <p><input type="checkbox"/> Biodiversity Areas and Corridors: Areas of habitat that are relatively important to various species of native fish and wildlife <i>(full descriptions in WDFW PHS report p. 152).</i></p> <p><input type="checkbox"/> Herbaceous Balds: Variable size patches of grass and forbs on shallow soils over bedrock.</p> <p><input type="checkbox"/> Old-growth/Mature forests: (Old-growth west of Cascade crest) Stands of at least 2 tree species, forming a multi-layered canopy with occasional small openings; with at least 20 trees/ha (8 trees/acre) > 81 cm (32 in) dbh or > 200 years of age. (Mature forests) Stands with average diameters exceeding 53 cm (21 in) dbh; crown cover may be less than 100%; decay, decadence, numbers of snags, and quantity of large downed material is generally less than that found in old-growth; 80 - 200 years old west of the Cascade crest.</p> <p><input type="checkbox"/> Oregon white Oak: Woodlands Stands of pure oak or oak/conifer associations where canopy coverage of the oak component is important <i>(full descriptions in WDFW PHS report p. 158).</i></p> <p><input type="checkbox"/> Riparian: The area adjacent to aquatic systems with flowing water that contains elements of both aquatic and terrestrial ecosystems which mutually influence each other.</p> <p><input type="checkbox"/> Westside Prairies: Herbaceous, non-forested plant communities that can either take the form of a dry prairie or a wet prairie <i>(full descriptions in WDFW PHS report p. 161).</i></p> <p><input type="checkbox"/> Instream: The combination of physical, biological, and chemical processes and conditions that interact to provide functional life history requirements for instream fish and wildlife resources.</p> <p><input type="checkbox"/> Nearshore: Relatively undisturbed nearshore habitats. These include Coastal Nearshore, Open Coast Nearshore, and Puget Sound Nearshore. <i>(full descriptions of habitats and the definition of relatively undisturbed are in WDFW report: pp. 167-169 and glossary in Appendix A).</i></p> <p><input type="checkbox"/> Caves: A naturally occurring cavity, recess, void, or system of interconnected passages under the earth in soils, rock, ice, or other geological formations and is large enough to contain a human.</p> <p><input type="checkbox"/> Cliffs: Greater than 7.6 m (25 ft) high and occurring below 5000 ft.</p> <p><input type="checkbox"/> Talus: Homogenous areas of rock rubble ranging in average size 0.15 - 2.0 m (0.5 - 6.5 ft), composed of basalt, andesite, and/or sedimentary rock, including riprap slides and mine tailings. May be associated with cliffs.</p> <p><input type="checkbox"/> Snags and Logs: Trees are considered snags if they are dead or dying and exhibit sufficient decay characteristics to enable cavity excavation/use by wildlife. Priority snags have a diameter at breast height of > 51 cm (20 in) in western Washington and are > 2 m (6.5 ft) in height. Priority logs are > 30 cm (12 in) in diameter at the largest end, and > 6 m (20 ft) long.</p> <p style="text-align: right;">If wetland has 3 or more priority habitats = 4 points If wetland has 2 priority habitats = 3 points If wetland has 1 priority habitat = 1 point No habitats = 0 points</p> <p>Note: All vegetated wetlands are by definition a priority habitat but are not included in this list. Nearby wetlands are addressed in question H 2.4)</p>	0
	<p>H 2.4 <u>Wetland Landscape:</u> <i>Choose the one description of the landscape around the wetland that best fits (see p. 84)</i></p> <ul style="list-style-type: none"> • There are at least 3 other wetlands within 1/2 mile, and the connections between them are relatively undisturbed (light grazing between wetlands OK, as is lake shore with some boating, but connections should NOT be bisected by paved roads, fill, fields, or other development.... points = 5 <input type="checkbox"/> • The wetland is Lake-fringe on a lake with little disturbance and there are 3 other lake-fringe wetlands within 1/2 mile points = 5 <input type="checkbox"/> • There are at least 3 other wetlands within 1/2 mile, BUT the connections between them are disturbed. points = 3 <input checked="" type="checkbox"/> • The wetland fringe on a lake with disturbance and there are 3 other lake-fringe wetlands within 1/2 mile points = 3 <input type="checkbox"/> • There is at least 1 wetland within 1/2 mile points = 2 <input type="checkbox"/> • There are no wetlands within 1/2 mile..... points = 0 <input type="checkbox"/> 	3
	<p>H 2 TOTAL Score – opportunity for providing habitat <i>Add the scores from H2.1, H2.2, H2.3, H2.4</i></p>	4
	<p style="text-align: right;"><i>TOTAL for H 1 from page 8</i></p>	7
◆	<p>Total Score for Habitat Functions <i>Add the points for H 1 and H 2; then record the result on p. 1</i></p>	11

Comments: _____

CATEGORIZATION BASED ON SPECIAL CHARACTERISTICS

Please determine if the wetland meets the attributes described below and circle the appropriate answers and Category.

Wetland Type – Check off any criteria that apply to the wetland. Circle the Category when the appropriate criteria are met.	
SC1	<p>Estuarine wetlands? (see p.86)</p> <p>Does the wetland unit meet the following criteria for Estuarine wetlands?</p> <p><input type="checkbox"/> The dominant water regime is tidal, <input type="checkbox"/> Vegetated, and <input type="checkbox"/> With a salinity greater than 0.5 ppt.</p> <p style="text-align: center;"><input type="checkbox"/> YES = Go to SC 1.1 <input checked="" type="checkbox"/> NO</p>
	<p>SC 1.1 Is the wetland unit within a National Wildlife Refuge, National Park, National Estuary Reserve, Natural Area Preserve, State Park or Educational, Environmental, or Scientific Reserve designated under WAC 332-30-151? <input type="checkbox"/> YES = Category I <input type="checkbox"/> NO = go to SC 1.2</p>
	<p>SC 1.2 Is the wetland at least 1 acre in size and meets at least two of the following conditions?</p> <p style="text-align: center;"><input type="checkbox"/> YES = Category I <input type="checkbox"/> NO = Category II</p> <p><input type="checkbox"/> The wetland is relatively undisturbed (has no diking, ditching, filling, cultivation, grazing, and has less than 10% cover of non-native plant species. If the non-native <i>Spartina</i> spp. are only species that cover more than 10% of the wetland, then the wetland should be given a dual rating (I/II). The area of <i>Spartina</i> would be rated a Category II while the relatively undisturbed upper marsh with native species would be a Category I. Do not, however, exclude the area of <i>Spartina</i> in determining the size threshold of 1 acre.</p> <p><input type="checkbox"/> At least 3/4 of the landward edge of the wetland has a 100 ft. buffer of shrub, forest, or un-grazed or un-mowed grassland</p> <p><input type="checkbox"/> The wetland has at least 2 of the following features: tidal channels, depressions with open water, or contiguous freshwater wetlands.</p>
SC2	<p>Natural Heritage Wetlands (see p. 87)</p> <p>Natural Heritage wetlands have been identified by the Washington Natural Heritage Program/DNR as either high quality undisturbed wetlands or wetlands that support state Threatened, Endangered, or Sensitive plant species.</p> <p>SC 2.1 Is the wetland being rated in a Section/Township/Range that contains a natural heritage wetland? (This question is used to screen out most sites before you need to contact WNHP/DNR.)</p> <p style="text-align: center;"><input type="checkbox"/> S/T/R information from Appendix D <input type="checkbox"/> or accessed from WNHP/DNR web site <input type="checkbox"/> YES Contact WNHP/DNR (see p. 79) and go to SC 2.2 <input checked="" type="checkbox"/> NO</p> <p>SC 2.2 Has DNR identified the wetland as a high quality undisturbed wetland or as a site with state threatened or endangered plant species?</p> <p style="text-align: center;"><input type="checkbox"/> YES = Category 1 <input checked="" type="checkbox"/> NO not a Heritage Wetland</p>
SC3	<p>Bogs (see p. 87)</p> <p>Does the wetland (or any part of the unit) meet both the criteria for soils and vegetation in bogs? Use the key below to identify if the wetland is a bog. If you answer yes you will still need to rate the wetland based on its function.</p> <ol style="list-style-type: none"> Does the unit have organic soil horizons (i.e. layers of organic soil), either peats or mucks, that compose 16 inches or more of the first 32 inches of soil profile? (See Appendix B for a field key to identify organic soils)? <input type="checkbox"/> YES = go to question 3 <input checked="" type="checkbox"/> NO = go to question 2 Does the wetland have organic soils, either peats or mucks that are less than 16 inches deep over bedrock, or an impermeable hardpan such as clay or volcanic ash, or that are floating on a lake or pond? <input type="checkbox"/> YES = go to question 3 <input checked="" type="checkbox"/> NO = is not a bog for purpose of rating Does the unit have more than 70% cover of mosses at ground level, AND other plants, if present, consist of the “bog” species listed in Table 3 as a significant component of the vegetation (more than 30% of the total shrub and herbaceous cover consists of species in Table 3)? <p style="text-align: center;"><input type="checkbox"/> YES = Is a bog for purpose of rating <input checked="" type="checkbox"/> NO = go to question 4</p> <p>NOTE: If you are uncertain about the extent of mosses in the understory you may substitute that criterion by measuring the pH of the water that seeps into a hole dug at least 16” deep. If the pH is less than 5.0 and the “bog” plant species in Table 3 are present, the wetland is a bog.</p> <ol style="list-style-type: none"> Is the unit forested (> 30% cover) with sitka spruce, subalpine fir, western red cedar, western hemlock, lodgepole pine, quaking aspen, Englemann’s spruce, or western white pine. WITH any of the species (or combination of species) on the bog species plant list in Table 3 as a significant component of the ground cover (> 30% coverage of the total shrub/herbaceous cover)? <p style="text-align: center;"><input type="checkbox"/> YES = Category I <input checked="" type="checkbox"/> NO = Is not a bog for purpose of rating</p>
	<p>Cat. I <input type="checkbox"/></p> <p>Cat. II <input type="checkbox"/></p> <p>Dual Rating I/II <input type="checkbox"/></p> <p>Cat I <input type="checkbox"/></p> <p>Cat. I <input type="checkbox"/></p>

SC4	<p>Forested Wetlands (see p. 90)</p> <p>Does the wetland have at least 1 acre of forest that meet one of these criteria for the Department of Fish and Wildlife’s forests as priority habitats? <i>If you answer yes you will still need to rate the wetland based on its function.</i></p> <p><input type="checkbox"/> Old-growth forests: (west of Cascade Crest) Stands of at least two three species forming a multi-layered canopy with occasional small openings; with at least 8 trees/acre (20 trees/hectare) that are at least 200 years of age OR have a diameter at breast height (dbh) of 32 inches (81 cm or more). NOTE: The criterion for dbh is based on measurements for upland forests. Two-hundred year old trees in wetlands will often have a smaller dbh because their growth rates are often slower. The DFW criterion is and “OR” so old-growth forests do not necessarily have to have trees of this diameter.</p> <p><input type="checkbox"/> Mature forests: (west of the Cascade Crest) Stands where the largest trees are 80 – 200 years old OR have an average diameters (dbh) exceeding 21 inches (53 cm); crown cover may be less than 100%; decay, decadence, numbers of snags, and quantity of large downed material is generally less than that found in old-growth.</p> <p><input type="checkbox"/> YES = Category I <input checked="" type="checkbox"/> NO = not a forested wetland with special characteristics</p>	<p>Cat. I <input type="checkbox"/></p>
SC5	<p>Wetlands in Coastal Lagoons (see p. 91)</p> <p>Does the wetland meet all of the following criteria of a wetland in a coastal lagoon?</p> <p><input type="checkbox"/> The wetland lies in a depression adjacent to marine waters that is wholly or partially separated from marine waters by sandbanks, gravel banks, shingle, or, less frequently, rocks.</p> <p><input type="checkbox"/> The lagoon in which the wetland is located contains surface water that is saline or brackish (> 0.5 ppt) during most of the year in at least a portion of the lagoon (<i>needs to be measured near the bottom.</i>)</p> <p><input type="checkbox"/> YES = Go to SC 5.1 <input checked="" type="checkbox"/> NO not a wetland in a coastal lagoon</p> <p>SC 5.1 Does the wetland meet all of the following three conditions?</p> <p><input type="checkbox"/> The wetland is relatively undisturbed (has no diking, ditching, filling, cultivation, grazing) and has less than 20% cover of invasive plant species (see list of invasive species on p. 74).</p> <p><input type="checkbox"/> At least 3/4 of the landward edge of the wetland has a 100 ft. buffer of shrub, forest, or un-grazed or un-mowed grassland.</p> <p><input type="checkbox"/> The wetland is larger than 1/10 acre (4350 square ft.)</p> <p><input type="checkbox"/> YES = Category I <input type="checkbox"/> NO = Category II</p>	<p style="background-color: #cccccc;">Cat. I <input type="checkbox"/></p> <p>Cat. II <input type="checkbox"/></p>
SC6	<p>Interdunal Wetlands (see p. 93)</p> <p>Is the wetland west of the 1889 line (also called the Western Boundary of Upland Ownership or WBUO)?</p> <p><input type="checkbox"/> YES = Go to SC 6.1 <input checked="" type="checkbox"/> NO not an interdunal wetland for rating</p> <p><i>If you answer yes you will still need to rate the wetland based on its functions.</i></p> <p>In practical terms that means the following geographic areas:</p> <ul style="list-style-type: none"> • Long Beach Peninsula -- lands west of SR 103 • Grayland-Westport -- lands west of SR 105 • Ocean Shores-Copalis – lands west of SR 115 and SR 109 <p>SC 6.1 Is the wetland one acre or larger, or is it in a mosaic of wetlands that is one acre or larger?</p> <p><input type="checkbox"/> YES = Category II <input type="checkbox"/> NO = go to SC 6.2</p> <p>SC 6.2 Is the wetland between 0.1 and 1 acre, or is it in a mosaic of wetlands that is between 0.1 and 1 acre?</p> <p><input type="checkbox"/> YES = Category III</p>	<p>Cat. II <input type="checkbox"/></p> <p>Cat. III <input type="checkbox"/></p>
◆	<p>Category of wetland based on Special Characteristics</p> <p><i>Choose the “highest” rating if wetland falls into several categories, and record on p. 1.</i></p> <p>If you answered NO for all types enter “Not Applicable” on p. 1</p>	<p>NA</p>

Comments:

WETLAND DETERMINATION DATA FORM – Western Mountains, Valleys, and Coast Region

Project Site: Bellevue Regional Pond City/County: /Bellevue Sampling Date: 8/2/2011
 Applicant/Owner: City of Bellevue State: WA Sampling Point: Kelsey West Tributary Pond
 Investigator(s): M. Maynard, C. Worsley Section, Township, Range: S28, T25N, R5E
 Landform (hillslope, terrace, etc.): Floodplain Local relief (concave, convex, none): none Slope (%): 1
 Subregion (LRR): A Lat: 47 37 29.90190 Long: 122 10 25.24783 Datum: NAD 83
 Soil Map Unit Name: Everett gravelly sandy loam, 5 to 15 percent slopes NWI classification: PEM
 Are climatic / hydrologic conditions on the site typical for this time of year? Yes No (If no, explain in Remarks.)
 Are Vegetation , Soil , or Hydrology , significantly disturbed? Are "Normal Circumstances" present? Yes No
 Are Vegetation , Soil , or Hydrology , naturally problematic? (If needed, explain any answers in Remarks.)

SUMMARY OF FINDINGS – Attach site map showing sampling point locations, transects, important features, etc.

Hydrophytic Vegetation Present?	Yes <input checked="" type="checkbox"/>	No <input type="checkbox"/>	Is the Sampled Area within a Wetland?		
Hydric Soil Present?	Yes <input checked="" type="checkbox"/>	No <input type="checkbox"/>		Yes <input checked="" type="checkbox"/>	No <input type="checkbox"/>
Wetland Hydrology Present?	Yes <input checked="" type="checkbox"/>	No <input type="checkbox"/>			
Remarks: Sample Plot W1-SP1 is located approximately 20 feet North northwest of Wetland Flag W1-22.					

VEGETATION – Use scientific names of plants

Tree Stratum (Plot size: _____)	Absolute % Cover	Dominant Species?	Indicator Status	Dominance Test Worksheet:																
1. _____	_____	_____	_____	Number of Dominant Species That Are OBL, FACW, or FAC: <u>2</u> (A) Total Number of Dominant Species Across All Strata: <u>2</u> (B) Percent of Dominant Species That Are OBL, FACW, or FAC: <u>100</u> (A/B)																
2. _____	_____	_____	_____																	
3. _____	_____	_____	_____																	
4. _____	_____	_____	_____																	
50% = _____, 20% = _____	_____	= Total Cover		Prevalence Index worksheet: <table style="width: 100%; border: none;"> <tr> <td style="text-align: center;"><u>Total % Cover of:</u></td> <td style="text-align: center;"><u>Multiply by:</u></td> </tr> <tr> <td>OBL species _____</td> <td>x1 = _____</td> </tr> <tr> <td>FACW species _____</td> <td>x2 = _____</td> </tr> <tr> <td>FAC species _____</td> <td>x3 = _____</td> </tr> <tr> <td>FACU species _____</td> <td>x4 = _____</td> </tr> <tr> <td>UPL species _____</td> <td>x5 = _____</td> </tr> <tr> <td>Column Totals: _____ (A)</td> <td>_____ (B)</td> </tr> <tr> <td colspan="2" style="text-align: center;">Prevalence Index = B/A = _____</td> </tr> </table>	<u>Total % Cover of:</u>	<u>Multiply by:</u>	OBL species _____	x1 = _____	FACW species _____	x2 = _____	FAC species _____	x3 = _____	FACU species _____	x4 = _____	UPL species _____	x5 = _____	Column Totals: _____ (A)	_____ (B)	Prevalence Index = B/A = _____	
<u>Total % Cover of:</u>	<u>Multiply by:</u>																			
OBL species _____	x1 = _____																			
FACW species _____	x2 = _____																			
FAC species _____	x3 = _____																			
FACU species _____	x4 = _____																			
UPL species _____	x5 = _____																			
Column Totals: _____ (A)	_____ (B)																			
Prevalence Index = B/A = _____																				
Sapling/Shrub Stratum (Plot size: _____)																				
1. _____	_____	_____	_____																	
2. _____	_____	_____	_____																	
3. _____	_____	_____	_____																	
4. _____	_____	_____	_____																	
5. _____	_____	_____	_____																	
50% = _____, 20% = _____	_____	= Total Cover																		
Herb Stratum (Plot size: _____)																				
1. <u><i>Typha latifolia</i></u>	<u>90</u>	<u>yes</u>	<u>OBL</u>																	
2. <u><i>Oenanthe sarmentosa</i></u>	<u>20</u>	<u>yes</u>	<u>OBL</u>																	
3. <u><i>Veronica americana</i></u>	<u>10</u>	<u>no</u>	<u>OBL</u>																	
4. <u><i>Myosotis laxa</i></u>	<u>2</u>	<u>no</u>	<u>OBL</u>																	
5. <u><i>Gallium trifidum</i></u>	<u>2</u>	<u>no</u>	<u>FACW</u>																	
6. <u><i>Callitriche heterophylla</i></u>	<u>15</u>	<u>no</u>	<u>OBL</u>																	
7. <u><i>Brassica sp.</i></u>	<u>5</u>	<u>no</u>	<u>NI</u>																	
8. <u><i>Sagittaria latifolia</i></u>	<u>2</u>	<u>no</u>	<u>OBL</u>																	
9. _____	_____	_____	_____																	
10. _____	_____	_____	_____																	
11. _____	_____	_____	_____																	
50% = _____, 20% = _____	_____	= Total Cover																		
Woody Vine Stratum (Plot size: _____)																				
1. _____	_____	_____	_____																	
2. _____	_____	_____	_____																	
50% = _____, 20% = _____	_____	= Total Cover																		
% Bare Ground in Herb Stratum _____																				
				Hydrophytic Vegetation Present? Yes <input checked="" type="checkbox"/> No <input type="checkbox"/>																

Remarks: *excluded from calculations per chapter 2 guidance

Project Site: _____

Sampling Point: Kelsey West Tributary Pond

SOIL

Profile Description: (Describe to the depth needed to document the indicator or confirm the absence of indicators.)

Depth (inches)	Matrix		Redox Features				Texture	Remarks
	Color (moist)	%	Color (moist)	%	Type ¹	Loc ²		
0-12	10YR 2/1	100	_____	_____	_____	_____	Silty muck	_____
12-19	2.5Y 4/1	100	_____	_____	_____	_____	Silt loam	Soil is historically disturbed (carbon)
_____	_____	_____	_____	_____	_____	_____	_____	_____
_____	_____	_____	_____	_____	_____	_____	_____	_____
_____	_____	_____	_____	_____	_____	_____	_____	_____
_____	_____	_____	_____	_____	_____	_____	_____	_____
_____	_____	_____	_____	_____	_____	_____	_____	_____

¹Type: C= Concentration, D=Depletion, RM=Reduced Matrix, CS=Covered or Coated Sand Grains. ²Location: PL=Pore Lining, M=Matrix

Hydric Soil Indicators: (Applicable to all LRRs, unless otherwise noted.)

- Histic Epipedon (A2)
- Black Histic (A3)
- Hydrogen Sulfide (A4)
- Depleted Below Dark Surface (A11)
- Thick Dark Surface (A12)
- Sandy Mucky Mineral (S1)
- Sandy Gleyed Matrix (S4)
- Sandy Redox (S5)
- Stripped Matrix (S6)
- Loamy Mucky Mineral (F1) **(except MLRA 1)**
- Loamy Gleyed Matrix (F2)
- Depleted Matrix (F3)
- Redox Dark Surface (F6)
- Depleted Dark Surface (F7)
- Redox Depressions (F8)

Indicators for Problematic Hydric Soils³:

- 2 cm Muck (A10)
- Red Parent Material (TF2)
- Very Shallow Dark Surface (TF12)
- Other (Explain in Remarks)

³Indicators of hydrophytic vegetation and wetland hydrology must be present, unless disturbed or problematic.

Restrictive Layer (if present):

Type: _____
 Depth (inches): _____

Hydric Soils Present? Yes No

Remarks:

HYDROLOGY

Wetland Hydrology Indicators:

Primary Indicators (minimum of one required; check all that apply)

- Surface Water (A1)
- High Water Table (A2)
- Saturation (A3)
- Water Marks (B1)
- Sediment Deposits (B2)
- Drift Deposits (B3)
- Algal Mat or Crust (B4)
- Iron Deposits (B5)
- Surface Soil Cracks (B6)
- Inundation Visible on Aerial Imagery (B7)
- Sparsely Vegetated Concave Surface (B8)
- Water-Stained Leaves (B9) **(except MLRA 1, 2, 4A, and 4B)**
- Salt Crust (B11)
- Aquatic Invertebrates (B13)
- Hydrogen Sulfide Odor (C1)
- Oxidized Rhizospheres along Living Roots (C3)
- Presence of Reduced Iron (C4)
- Recent Iron Reduction in Tilled Soils (C6)
- Stunted or Stresses Plants (D1) **(LRR A)**
- Other (Explain in Remarks)

Secondary Indicators (2 or more required)

- Water-Stained Leaves (B9) **(MLRA 1, 2, 4A, and 4B)**
- Drainage Patterns (B10)
- Dry-Season Water Table (C2)
- Saturation Visible on Aerial Imagery (C9)
- Geomorphic Position (D2)
- Shallow Aquitard (D3)
- FAC-Neutral Test (D5)
- Raised Ant Mounds (D6) **(LRR A)**
- Frost-Heave Hummocks (D7)

Field Observations:

Surface Water Present? Yes No Depth (inches): _____
 Water Table Present? Yes No Depth (inches): 3
 Saturation Present? (includes capillary fringe) Yes No Depth (inches): Surface

Wetland Hydrology Present? Yes No

Describe Recorded Data (stream gauge, monitoring well, aerial photos, previous inspections), if available:

Remarks:

WETLAND DETERMINATION DATA FORM – Western Mountains, Valleys, and Coast Region

Project Site: Bellevue Regional Pond City/County: /Bellevue Sampling Date: 8/2/2011
 Applicant/Owner: City of Bellevue State: WA Sampling Point: Kelsey West Tributary Pond
 Investigator(s): M. Maynard, C. Worsley Section, Township, Range: S28, T25N, R5E
 Landform (hillslope, terrace, etc.): Hillslope Local relief (concave, convex, none): none Slope (%): 5
 Subregion (LRR): A Lat: 47 37 29.83297 Long: 122 10 25.67617 Datum: NAD 83
 Soil Map Unit Name: Everett gravelly sandy loam, 5 to 15 percent slopes NWI classification: Upland shrub
 Are climatic / hydrologic conditions on the site typical for this time of year? Yes No (If no, explain in Remarks.)
 Are Vegetation , Soil , or Hydrology , significantly disturbed? Are "Normal Circumstances" present? Yes No
 Are Vegetation , Soil , or Hydrology , naturally problematic? (If needed, explain any answers in Remarks.)

SUMMARY OF FINDINGS – Attach site map showing sampling point locations, transects, important features, etc.

Hydrophytic Vegetation Present?	Yes <input checked="" type="checkbox"/>	No <input type="checkbox"/>	Is the Sampled Area within a Wetland?	Yes <input type="checkbox"/>	No <input checked="" type="checkbox"/>
Hydric Soil Present?	Yes <input type="checkbox"/>	No <input checked="" type="checkbox"/>		Yes <input type="checkbox"/>	No <input checked="" type="checkbox"/>
Wetland Hydrology Present?	Yes <input type="checkbox"/>	No <input checked="" type="checkbox"/>		Yes <input type="checkbox"/>	No <input checked="" type="checkbox"/>
Remarks: Sample Plot W1-SP2 is located approximately 20 feet northwest of Wetland Flag W1-22.					

VEGETATION – Use scientific names of plants

Tree Stratum (Plot size: _____)	Absolute % Cover	Dominant Species?	Indicator Status	Dominance Test Worksheet:																
1. <u><i>Alnus rubra</i></u>	<u>60</u>	<u>yes</u>	<u>FAC</u>	Number of Dominant Species That Are OBL, FACW, or FAC: <u>2</u> (A) Total Number of Dominant Species Across All Strata: <u>3</u> (B) Percent of Dominant Species That Are OBL, FACW, or FAC: <u>66</u> (A/B)																
2. <u><i>Populus balsamifera</i></u>	<u>40</u>	<u>yes</u>	<u>FAC</u>																	
3. _____	_____	_____	_____																	
4. _____	_____	_____	_____																	
50% = _____, 20% = _____	_____	= Total Cover		Prevalence Index worksheet: <table style="width: 100%; border: none;"> <tr> <td style="text-align: center;"><u>Total % Cover of:</u></td> <td style="text-align: center;"><u>Multiply by:</u></td> </tr> <tr> <td>OBL species _____</td> <td>x1 = _____</td> </tr> <tr> <td>FACW species _____</td> <td>x2 = _____</td> </tr> <tr> <td>FAC species _____</td> <td>x3 = _____</td> </tr> <tr> <td>FACU species _____</td> <td>x4 = _____</td> </tr> <tr> <td>UPL species _____</td> <td>x5 = _____</td> </tr> <tr> <td>Column Totals: _____ (A)</td> <td>_____ (B)</td> </tr> <tr> <td colspan="2" style="text-align: center;">Prevalence Index = B/A = _____</td> </tr> </table>	<u>Total % Cover of:</u>	<u>Multiply by:</u>	OBL species _____	x1 = _____	FACW species _____	x2 = _____	FAC species _____	x3 = _____	FACU species _____	x4 = _____	UPL species _____	x5 = _____	Column Totals: _____ (A)	_____ (B)	Prevalence Index = B/A = _____	
<u>Total % Cover of:</u>	<u>Multiply by:</u>																			
OBL species _____	x1 = _____																			
FACW species _____	x2 = _____																			
FAC species _____	x3 = _____																			
FACU species _____	x4 = _____																			
UPL species _____	x5 = _____																			
Column Totals: _____ (A)	_____ (B)																			
Prevalence Index = B/A = _____																				
Sapling/Shrub Stratum (Plot size: _____)																				
1. <u><i>Cornus sericea</i></u>	<u>7</u>	<u>no</u>	<u>FACW</u>																	
2. <u><i>Oemleria cerasiformis</i></u>	<u>2</u>	<u>no</u>	<u>FACU</u>																	
3. _____	_____	_____	_____																	
4. _____	_____	_____	_____																	
5. _____	_____	_____	_____																	
50% = _____, 20% = _____	_____	= Total Cover																		
Herb Stratum (Plot size: _____)																				
1. _____	_____	_____	_____																	
2. _____	_____	_____	_____																	
3. _____	_____	_____	_____																	
4. _____	_____	_____	_____																	
5. _____	_____	_____	_____																	
6. _____	_____	_____	_____																	
7. _____	_____	_____	_____																	
8. _____	_____	_____	_____																	
9. _____	_____	_____	_____																	
10. _____	_____	_____	_____																	
11. _____	_____	_____	_____																	
50% = _____, 20% = _____	_____	= Total Cover																		
Woody Vine Stratum (Plot size: _____)																				
1. <u><i>Rubus armeniacus</i></u>	<u>90</u>	<u>yes</u>	<u>FACU</u>																	
2. _____	_____	_____	_____																	
50% = _____, 20% = _____	_____	= Total Cover																		
% Bare Ground in Herb Stratum _____																				
Hydrophytic Vegetation Indicators: <input type="checkbox"/> 1 – Rapid Test for Hydrophytic Vegetation <input type="checkbox"/> 2 - Dominance Test is >50% <input type="checkbox"/> 3 - Prevalence Index is ≤3.0 ¹ <input type="checkbox"/> 4 - Morphological Adaptations ¹ (Provide supporting data in Remarks or on a separate sheet) <input type="checkbox"/> 5 - Wetland Non-Vascular Plants ¹ <input type="checkbox"/> Problematic Hydrophytic Vegetation ¹ (Explain)																				
¹ Indicators of hydric soil and wetland hydrology must be present, unless disturbed or problematic.																				
Hydrophytic Vegetation Present? Yes <input checked="" type="checkbox"/> No <input type="checkbox"/>																				
Remarks:																				

Project Site: _____

Sampling Point: Kelsey West Tributary Pond

SOIL

Profile Description: (Describe to the depth needed to document the indicator or confirm the absence of indicators.)

Depth (inches)	Matrix		Redox Features				Texture	Remarks
	Color (moist)	%	Color (moist)	%	Type ¹	Loc ²		
0-18	2.5Y 3/2	100	_____	_____	_____	_____	Silt loam	_____
_____	_____	_____	_____	_____	_____	_____	_____	_____
_____	_____	_____	_____	_____	_____	_____	_____	_____
_____	_____	_____	_____	_____	_____	_____	_____	_____
_____	_____	_____	_____	_____	_____	_____	_____	_____
_____	_____	_____	_____	_____	_____	_____	_____	_____

¹Type: C= Concentration, D=Depletion, RM=Reduced Matrix, CS=Covered or Coated Sand Grains. ²Location: PL=Pore Lining, M=Matrix

Hydric Soil Indicators: (Applicable to all LRRs, unless otherwise noted.)		Indicators for Problematic Hydric Soils³:	
<input type="checkbox"/> Histosol (A1)	<input type="checkbox"/> Sandy Redox (S5)	<input type="checkbox"/> 2 cm Muck (A10)	
<input type="checkbox"/> Histic Epipedon (A2)	<input type="checkbox"/> Stripped Matrix (S6)	<input type="checkbox"/> Red Parent Material (TF2)	
<input type="checkbox"/> Black Histic (A3)	<input type="checkbox"/> Loamy Mucky Mineral (F1) (except MLRA 1)	<input type="checkbox"/> Very Shallow Dark Surface (TF12)	
<input type="checkbox"/> Hydrogen Sulfide (A4)	<input type="checkbox"/> Loamy Gleyed Matrix (F2)	<input type="checkbox"/> Other (Explain in Remarks)	
<input type="checkbox"/> Depleted Below Dark Surface (A11)	<input type="checkbox"/> Depleted Matrix (F3)		
<input type="checkbox"/> Thick Dark Surface (A12)	<input type="checkbox"/> Redox Dark Surface (F6)		
<input type="checkbox"/> Sandy Mucky Mineral (S1)	<input type="checkbox"/> Depleted Dark Surface (F7)		
<input type="checkbox"/> Sandy Gleyed Matrix (S4)	<input type="checkbox"/> Redox Depressions (F8)		

³Indicators of hydrophytic vegetation and wetland hydrology must be present, unless disturbed or problematic.

Restrictive Layer (if present): Type: _____ Depth (inches): _____	Hydric Soils Present? Yes <input type="checkbox"/> No <input checked="" type="checkbox"/>
--	--

Remarks: _____

HYDROLOGY

Wetland Hydrology Indicators:

Primary Indicators (minimum of one required; check all that apply)		Secondary Indicators (2 or more required)	
<input type="checkbox"/> Surface Water (A1)	<input type="checkbox"/> Water-Stained Leaves (B9)	<input type="checkbox"/> Water-Stained Leaves (B9)	
<input type="checkbox"/> High Water Table (A2)	(except MLRA 1, 2, 4A, and 4B)	(MLRA 1, 2, 4A, and 4B)	
<input type="checkbox"/> Saturation (A3)	<input type="checkbox"/> Salt Crust (B11)	<input type="checkbox"/> Drainage Patterns (B10)	
<input type="checkbox"/> Water Marks (B1)	<input type="checkbox"/> Aquatic Invertebrates (B13)	<input type="checkbox"/> Dry-Season Water Table (C2)	
<input type="checkbox"/> Sediment Deposits (B2)	<input type="checkbox"/> Hydrogen Sulfide Odor (C1)	<input type="checkbox"/> Saturation Visible on Aerial Imagery (C9)	
<input type="checkbox"/> Drift Deposits (B3)	<input type="checkbox"/> Oxidized Rhizospheres along Living Roots (C3)	<input type="checkbox"/> Geomorphic Position (D2)	
<input type="checkbox"/> Algal Mat or Crust (B4)	<input type="checkbox"/> Presence of Reduced Iron (C4)	<input type="checkbox"/> Shallow Aquitard (D3)	
<input type="checkbox"/> Iron Deposits (B5)	<input type="checkbox"/> Recent Iron Reduction in Tilled Soils (C6)	<input type="checkbox"/> FAC-Neutral Test (D5)	
<input type="checkbox"/> Surface Soil Cracks (B6)	<input type="checkbox"/> Stunted or Stresses Plants (D1) (LRR A)	<input type="checkbox"/> Raised Ant Mounds (D6) (LRR A)	
<input type="checkbox"/> Inundation Visible on Aerial Imagery (B7)	<input type="checkbox"/> Other (Explain in Remarks)	<input type="checkbox"/> Frost-Heave Hummocks (D7)	
<input type="checkbox"/> Sparsely Vegetated Concave Surface (B8)			

Field Observations: Surface Water Present? Yes <input type="checkbox"/> No <input checked="" type="checkbox"/> Depth (inches): _____ Water Table Present? Yes <input type="checkbox"/> No <input checked="" type="checkbox"/> Depth (inches): _____ Saturation Present? (includes capillary fringe) Yes <input type="checkbox"/> No <input checked="" type="checkbox"/> Depth (inches): _____	Wetland Hydrology Present? Yes <input type="checkbox"/> No <input checked="" type="checkbox"/>
--	---

Describe Recorded Data (stream gauge, monitoring well, aerial photos, previous inspections), if available: _____

Remarks: No indicators of hydrology were observed during the site investigation.

WETLAND DETERMINATION DATA FORM – Western Mountains, Valleys, and Coast Region

Project Site: Bellevue Regional Pond City/County: /Bellevue Sampling Date: 8/2/2011
 Applicant/Owner: City of Bellevue State: WA Sampling Point: Kelsey West Tributary Pond
 Investigator(s): M. Maynard, C. Worsley Section, Township, Range: S28, T25N, R5E
 Landform (hillslope, terrace, etc.): Floodplain Local relief (concave, convex, none): none Slope (%): 1
 Subregion (LRR): A Lat: 47 37 28.54624 Long: 122 10 16.73526 Datum: NAD 83
 Soil Map Unit Name: Everett gravelly sandy loam, 5 to 15 percent slopes NWI classification: PFO
 Are climatic / hydrologic conditions on the site typical for this time of year? Yes No (If no, explain in Remarks.)
 Are Vegetation , Soil , or Hydrology , significantly disturbed? Are "Normal Circumstances" present? Yes No
 Are Vegetation , Soil , or Hydrology , naturally problematic? (If needed, explain any answers in Remarks.)

SUMMARY OF FINDINGS – Attach site map showing sampling point locations, transects, important features, etc.

Hydrophytic Vegetation Present?	Yes <input checked="" type="checkbox"/>	No <input type="checkbox"/>	Is the Sampled Area within a Wetland?	Yes <input checked="" type="checkbox"/>	No <input type="checkbox"/>
Hydric Soil Present?	Yes <input checked="" type="checkbox"/>	No <input type="checkbox"/>		Yes <input checked="" type="checkbox"/>	No <input type="checkbox"/>
Wetland Hydrology Present?	Yes <input checked="" type="checkbox"/>	No <input type="checkbox"/>		Yes <input checked="" type="checkbox"/>	No <input type="checkbox"/>
Remarks: Sample Plot W1-SP3 is located approximately 30 feet south of Wetland Flag W1-74.					

VEGETATION – Use scientific names of plants

<u>Tree Stratum</u> (Plot size: _____)	Absolute % Cover	Dominant Species?	Indicator Status	Dominance Test Worksheet:																
1. <u>Salix lucida</u>	<u>75</u>	<u>yes</u>	<u>FACW</u>	Number of Dominant Species That Are OBL, FACW, or FAC: <u>2</u> (A)																
2. _____	_____	_____	_____	Total Number of Dominant Species Across All Strata: <u>2</u> (B)																
3. _____	_____	_____	_____	Percent of Dominant Species That Are OBL, FACW, or FAC: <u>100</u> (A/B)																
4. _____	_____	_____	_____																	
50% = _____, 20% = _____	<u>75</u>	= Total Cover																		
<u>Sapling/Shrub Stratum</u> (Plot size: _____)	Absolute % Cover	Dominant Species?	Indicator Status	Prevalence Index worksheet:																
1. <u>Spirea douglasii</u>	<u>5</u>	<u>no</u>	<u>FACW</u>	<table style="width: 100%; border-collapse: collapse;"> <tr> <td style="text-align: center;"><u>Total % Cover of:</u></td> <td style="text-align: center;"><u>Multiply by:</u></td> </tr> <tr> <td>OBL species _____</td> <td>x1 = _____</td> </tr> <tr> <td>FACW species _____</td> <td>x2 = _____</td> </tr> <tr> <td>FAC species _____</td> <td>x3 = _____</td> </tr> <tr> <td>FACU species _____</td> <td>x4 = _____</td> </tr> <tr> <td>UPL species _____</td> <td>x5 = _____</td> </tr> <tr> <td>Column Totals: _____ (A)</td> <td>_____ (B)</td> </tr> <tr> <td colspan="2" style="text-align: center;">Prevalence Index = B/A = _____</td> </tr> </table>	<u>Total % Cover of:</u>	<u>Multiply by:</u>	OBL species _____	x1 = _____	FACW species _____	x2 = _____	FAC species _____	x3 = _____	FACU species _____	x4 = _____	UPL species _____	x5 = _____	Column Totals: _____ (A)	_____ (B)	Prevalence Index = B/A = _____	
<u>Total % Cover of:</u>	<u>Multiply by:</u>																			
OBL species _____	x1 = _____																			
FACW species _____	x2 = _____																			
FAC species _____	x3 = _____																			
FACU species _____	x4 = _____																			
UPL species _____	x5 = _____																			
Column Totals: _____ (A)	_____ (B)																			
Prevalence Index = B/A = _____																				
2. <u>Cornus sericea</u>	<u>2</u>	<u>no</u>	<u>FACW</u>																	
3. _____	_____	_____	_____																	
4. _____	_____	_____	_____																	
5. _____	_____	_____	_____																	
50% = _____, 20% = _____	<u>7</u>	= Total Cover																		
<u>Herb Stratum</u> (Plot size: _____)	Absolute % Cover	Dominant Species?	Indicator Status	Hydrophytic Vegetation Indicators:																
1. <u>Phalaris arundinacea</u>	<u>40</u>	<u>yes</u>	<u>FACW</u>	<input type="checkbox"/> 1 – Rapid Test for Hydrophytic Vegetation <input type="checkbox"/> 2 - Dominance Test is >50% <input type="checkbox"/> 3 - Prevalence Index is ≤3.0 ¹ <input type="checkbox"/> 4 - Morphological Adaptations ¹ (Provide supporting data in Remarks or on a separate sheet) <input type="checkbox"/> 5 - Wetland Non-Vascular Plants ¹ <input type="checkbox"/> Problematic Hydrophytic Vegetation ¹ (Explain) ¹ Indicators of hydric soil and wetland hydrology must be present, unless disturbed or problematic.																
2. _____	_____	_____	_____																	
3. _____	_____	_____	_____																	
4. _____	_____	_____	_____																	
5. _____	_____	_____	_____																	
6. _____	_____	_____	_____																	
7. _____	_____	_____	_____																	
8. _____	_____	_____	_____																	
9. _____	_____	_____	_____																	
10. _____	_____	_____	_____																	
11. _____	_____	_____	_____																	
50% = _____, 20% = _____	<u>40</u>	= Total Cover																		
<u>Woody Vine Stratum</u> (Plot size: _____)	Absolute % Cover	Dominant Species?	Indicator Status	Hydrophytic Vegetation Present?																
1. _____	_____	_____	_____	Yes <input checked="" type="checkbox"/> No <input type="checkbox"/>																
2. _____	_____	_____	_____																	
50% = _____, 20% = _____	_____	= Total Cover																		
% Bare Ground in Herb Stratum _____																				

Remarks: *excluded from calculations per chapter 2 guidance

Project Site: _____

Sampling Point: Kelsey West Tributary Pond

SOIL

Profile Description: (Describe to the depth needed to document the indicator or confirm the absence of indicators.)

Depth (inches)	Matrix		Redox Features				Texture	Remarks
	Color (moist)	%	Color (moist)	%	Type ¹	Loc ²		
0-5	10YR 3/1	100	_____	_____	_____	_____	Loam	Many roots in layer
5-9	2.5Y 4/1	100	_____	_____	_____	_____	Sandy loam	_____
9-18	5Y 5/1	90	7.5YR 3/4	10	c	M	Gr Sa Loam	Cobbles and carbon in layer
_____	_____	_____	_____	_____	_____	_____	_____	_____
_____	_____	_____	_____	_____	_____	_____	_____	_____
_____	_____	_____	_____	_____	_____	_____	_____	_____
_____	_____	_____	_____	_____	_____	_____	_____	_____

¹Type: C= Concentration, D=Depletion, RM=Reduced Matrix, CS=Covered or Coated Sand Grains. ²Location: PL=Pore Lining, M=Matrix

Hydric Soil Indicators: (Applicable to all LRRs, unless otherwise noted.)		Indicators for Problematic Hydric Soils³:	
<input type="checkbox"/> Histosol (A1)	<input type="checkbox"/> Sandy Redox (S5)	<input type="checkbox"/> 2 cm Muck (A10)	
<input type="checkbox"/> Histic Epipedon (A2)	<input type="checkbox"/> Stripped Matrix (S6)	<input type="checkbox"/> Red Parent Material (TF2)	
<input type="checkbox"/> Black Histic (A3)	<input type="checkbox"/> Loamy Mucky Mineral (F1) (except MLRA 1)	<input type="checkbox"/> Very Shallow Dark Surface (TF12)	
<input type="checkbox"/> Hydrogen Sulfide (A4)	<input type="checkbox"/> Loamy Gleyed Matrix (F2)	<input type="checkbox"/> Other (Explain in Remarks)	
<input type="checkbox"/> Depleted Below Dark Surface (A11)	<input type="checkbox"/> Depleted Matrix (F3)		
<input type="checkbox"/> Thick Dark Surface (A12)	<input checked="" type="checkbox"/> Redox Dark Surface (F6)		
<input type="checkbox"/> Sandy Mucky Mineral (S1)	<input type="checkbox"/> Depleted Dark Surface (F7)		
<input type="checkbox"/> Sandy Gleyed Matrix (S4)	<input type="checkbox"/> Redox Depressions (F8)		

³Indicators of hydrophytic vegetation and wetland hydrology must be present, unless disturbed or problematic.

Restrictive Layer (if present): Type: _____ Depth (inches): _____	Hydric Soils Present? Yes <input checked="" type="checkbox"/> No <input type="checkbox"/>
--	--

Remarks:

HYDROLOGY

Wetland Hydrology Indicators:
Primary Indicators (minimum of one required; check all that apply) Secondary Indicators (2 or more required)

<input type="checkbox"/> Surface Water (A1)	<input type="checkbox"/> Water-Stained Leaves (B9)	<input type="checkbox"/> Water-Stained Leaves (B9)
<input checked="" type="checkbox"/> High Water Table (A2)	(except MLRA 1, 2, 4A, and 4B)	(MLRA 1, 2, 4A, and 4B)
<input checked="" type="checkbox"/> Saturation (A3)	<input type="checkbox"/> Salt Crust (B11)	<input type="checkbox"/> Drainage Patterns (B10)
<input type="checkbox"/> Water Marks (B1)	<input type="checkbox"/> Aquatic Invertebrates (B13)	<input type="checkbox"/> Dry-Season Water Table (C2)
<input type="checkbox"/> Sediment Deposits (B2)	<input type="checkbox"/> Hydrogen Sulfide Odor (C1)	<input type="checkbox"/> Saturation Visible on Aerial Imagery (C9)
<input type="checkbox"/> Drift Deposits (B3)	<input type="checkbox"/> Oxidized Rhizospheres along Living Roots (C3)	<input type="checkbox"/> Geomorphic Position (D2)
<input type="checkbox"/> Algal Mat or Crust (B4)	<input type="checkbox"/> Presence of Reduced Iron (C4)	<input type="checkbox"/> Shallow Aquitard (D3)
<input type="checkbox"/> Iron Deposits (B5)	<input type="checkbox"/> Recent Iron Reduction in Tilled Soils (C6)	<input type="checkbox"/> FAC-Neutral Test (D5)
<input type="checkbox"/> Surface Soil Cracks (B6)	<input type="checkbox"/> Stunted or Stresses Plants (D1) (LRR A)	<input type="checkbox"/> Raised Ant Mounds (D6) (LRR A)
<input type="checkbox"/> Inundation Visible on Aerial Imagery (B7)	<input type="checkbox"/> Other (Explain in Remarks)	<input type="checkbox"/> Frost-Heave Hummocks (D7)
<input type="checkbox"/> Sparsely Vegetated Concave Surface (B8)		

Field Observations: Surface Water Present? Yes <input type="checkbox"/> No <input checked="" type="checkbox"/> Depth (inches): _____ Water Table Present? Yes <input checked="" type="checkbox"/> No <input type="checkbox"/> Depth (inches): <u>15</u> Saturation Present? (includes capillary fringe) Yes <input checked="" type="checkbox"/> No <input type="checkbox"/> Depth (inches): <u>Surface</u>	Wetland Hydrology Present? Yes <input checked="" type="checkbox"/> No <input type="checkbox"/>
--	---

Describe Recorded Data (stream gauge, monitoring well, aerial photos, previous inspections), if available:

Remarks:

WETLAND RATING FORM – WESTERN WASHINGTON
 Version 2 – Updated July 2006 to increase accuracy and reproducibility among users
 Updated Oct. 2008 with the new WDFW definitions for priority habitats

Name of wetland (if known): Kelsey West Vribwet{ Pond

Date of site visit: April 9, 2013

Rated by: C. Douglas & J. Pursley Trained by Ecology? Yes No

Date of training: May 2007

SEC: 28 TOWNSHP: 24N RNGE: 5E

Is S/T/R in Appendix D? Yes No

Map of wetland unit: Figure _____ Estimated size _____

SUMMARY OF RATING

Category based on FUNCTIONS provided by wetland: I II III IV

Category I =	Score > 70
Category II =	Score 51 - 69
Category III =	Score 30 – 50
Category IV =	Score < 30

Score for Water Quality Functions	26
Score for Hydrologic Functions	24
Score for Habitat Functions	24
TOTAL Score for Functions	74

Category based on SPECIAL CHARACTERISTICS of Wetland I II Does not apply

Final Category (choose the “highest” category from above”)

I

Summary of basic information about the wetland unit.

Wetland Unit has Special Characteristics		Wetland HGM Class used for Rating	
Estuarine	<input type="checkbox"/>	Depressional	<input checked="" type="checkbox"/>
Natural Heritage Wetland	<input type="checkbox"/>	Riverine	<input checked="" type="checkbox"/>
Bog	<input type="checkbox"/>	Lake-fringe	<input type="checkbox"/>
Mature Forest	<input type="checkbox"/>	Slope	<input type="checkbox"/>
Old Growth Forest	<input type="checkbox"/>	Flats	<input type="checkbox"/>
Coastal Lagoon	<input type="checkbox"/>	Freshwater Tidal	<input type="checkbox"/>
Interdunal	<input type="checkbox"/>		<input type="checkbox"/>
None of the above	<input checked="" type="checkbox"/>	Check if unit has multiple HGM classes present	<input checked="" type="checkbox"/>

Does the wetland being rated meet any of the criteria below? If you answer YES to any of the questions below you will need to protect the wetland according to the regulations regarding the special characteristics found in the wetland.

Check List for Wetlands that Need Additional Protection (in addition to the protection recommended for its category)	YES	NO
SP1. <i>Has the wetland unit been documented as a habitat for any Federally listed Threatened or Endangered animal or plant species (T/E species)?</i> For the purposes of this rating system, “documented” means the wetland is on the appropriate state or federal database.	<input type="checkbox"/>	<input checked="" type="checkbox"/>
SP2. <i>Has the wetland unit been documented as habitat for any State listed Threatened or Endangered animal species?</i> For the purposes of this rating system, “documented” means the wetland is on the appropriate state database. Note: Wetlands with State listed plant species are categorized as Category 1 Natural Heritage Wetlands (see p. 19 of data form).	<input type="checkbox"/>	<input checked="" type="checkbox"/>
SP3. <i>Does the wetland unit contain individuals of Priority species listed by the WDFW for the state?</i>	<input type="checkbox"/>	<input checked="" type="checkbox"/>
SP4. <i>Does the wetland unit have a local significance in addition to its functions?</i> For example, the wetland has been identified in the Shoreline Master Program, the Critical Areas Ordinance, or in a local management plan as having special significance.	<input type="checkbox"/>	<input checked="" type="checkbox"/>

To complete the next part of the data sheet you will need to determine the Hydrogeomorphic Class of the wetland being rated.

The hydrogeomorphic classification groups wetlands in to those that function in similar ways. This simplifies the questions needed to answer how well the wetland functions. The Hydrogeomorphic Class of a wetland can be determined using the key below. See p. 24 for more detailed instructions on classifying wetlands.

Classification of Vegetated Wetlands for Western Washington

If the hydrologic criteria listed in each question do not apply to the entire unit being rated, you probably have a unit with multiple HGM classes. In this case, identify which hydrologic criteria in questions 1-7 apply, and go to Question 8.

1. Are the water levels in the entire unit usually controlled by tides (i.e. except during floods)?
 NO – go to 2 YES – the wetland class is **Tidal Fringe**
 If yes, is the salinity of the water during periods of annual low flow below 0.5 ppt (parts per thousand)?
 YES – **Freshwater Tidal Fringe** NO – **Saltwater Tidal Fringe (Estuarine)**
*If your wetland can be classified as a Freshwater Tidal Fringe use the forms for **Riverine** wetlands. If it is a Saltwater Tidal Fringe it is rated as an **Estuarine** wetland. Wetlands that were call estuarine in the first and second editions of the rating system are called Salt Water Tidal Fringe in the Hydrogeomorphic Classification. Estuarine wetlands were categorized separately in the earlier editions, and this separation is being kept in this revision. To maintain consistency between editions, the term “Estuarine” wetland is kept. Please note, however, that the characteristics that define Category I and II estuarine wetlands have changed (see p. _____).*
-
2. The entire wetland unit is flat and precipitation is only source (>90%) of water to it. Groundwater and surface water runoff are NOT sources of water to the unit.
 NO – go to 3 YES – The wetland class is **Flats**
 If your wetland can be classified as a “Flats” wetland, use the form for **Depressional** wetlands.
-
3. Does the entire wetland meet both of the following criteria?
 The vegetated part of the wetland is on the shores of a body of permanent open water (without any vegetation on the surface) where at least 20 acres (8ha) in size;
 At least 30% of the open water area is deeper than 6.6 (2 m)?
 NO – go to 4 YES – The wetland class is **Lake-fringe (Lacustrine Fringe)**
-
4. Does the entire wetland meet all of the following criteria?
 The wetland is on a slope (*slope can be very gradual*).
 The water flows through the wetland in one direction (unidirectional) and usually comes from seeps. It may flow subsurface, as sheetflow, or in a swale without distinct banks.
 The water leaves the wetland **without being impounded**?
 NOTE: *Surface water does not pond in these types of wetlands except occasionally in very small and shallow depressions or behind hummocks (depressions are usually <3 ft diameter and less than 1 foot deep).*
 NO – go to 5 YES – The wetland class is **Slope**
-
5. Does the entire wetland meet all of the following criteria?
 The unit is in a valley or stream channel where it gets inundated by overbank flooding from that stream or river.
 The overbank flooding occurs at least once every two years.
 NOTE: *The riverine unit can contain depressions that are filled with water when the river is not flooding..*
 NO – go to 6 YES – The wetland class is **Riverine**
-
6. Is the entire wetland unit in a topographic depression in which water ponds, or is saturated to the surface, at some time of the year. This means that any outlet, if present is higher than the interior of the wetland.
 NO – go to 7 YES – The wetland class is **Depressional**
-
7. Is the entire wetland located in a very flat area with no obvious depression and no overbank flooding. The unit does not pond surface water more than a few inches. The unit seems to be maintained by high groundwater in the area. The wetland may be ditched, but has no obvious natural outlet.
 No – go to 8 YES – The wetland class is **Depressional**
-
8. Your wetland unit seems to be difficult to classify and probably contains several different HGM classes. For example, seeps at the base of a slope may grade into a riverine floodplain, or a small stream within a depressional wetland has a zone of flooding along its sides. GO BACK AND IDENTIFY WHICH OF THE HYDROLOGIC REGIMES DESCRIBED IN QUESTIONS 1-7 APPLY TO DIFFERENT AREAS IN THE UNIT (make a rough sketch to help you decide). Use the following table to identify the appropriate class to use for the rating system if you have several HGM classes present within your wetland. NOTE: Use this table only if the class that is recommended in the second column represents 10% or more of the total area of the wetland unit being rated. If the area of the class listed in column 2 is less than 10% of the unit, classify the wetland using the class that represents more than 90% of the total area.

HGM Classes within the wetland unit being rated	HGM Class to Use in Rating
Slope + Riverine	Riverine
Slope + Depressional	Depressional
Slope + Lake-fringe	Lake-fringe
Depressional + Riverine along stream within boundary	Depressional
Depressional + Lake-fringe	Depressional
Salt Water Tidal Fringe and any other class of freshwater wetland	Treat as ESTUARINE under wetlands with special characteristics

If you are unable still to determine which of the above criteria apply to your wetland, or you have more than 2 HGM classes within a wetland boundary, classify the wetland as **Depressional** for the rating.

D Depressional and Flat Wetlands		Points
WATER QUALITY FUNCTIONS – Indicators that wetland functions to improve water quality.		(only 1 score per box) (see p.38)
D 1	Does the wetland have the <u>potential</u> to improve water quality?	
D 1.1	Characteristics of surface water flows out of the wetland: • Unit is a depression with no surface water leaving it (no outlet) points = 3 <input type="checkbox"/> • Unit has an intermittently flowing, OR highly constricted, permanently flowing outlet ... points = 2 <input checked="" type="checkbox"/> • Unit has an unconstricted, or slightly constricted, surface outlet (<i>permanently flowing</i>) .. points = 1 <input type="checkbox"/> • Unit is a “flat” depression (Q.7 on key), or in the Flats class, with permanent surface outflow and no obvious natural outlet and/or outlet is a man-made ditch..... points = 1 <input type="checkbox"/> <i>(If ditch is not permanently flowing treat unit as “intermittently flowing”)</i> Provide photo or drawing	Figure <input type="checkbox"/> 2
D 1.2	The soil 2 inches below the surface (or duff layer) is clay or organic (<i>use NRCS definitions</i>) YES points = 4 NO points = 0	4
D 1.3	Characteristics of persistent vegetation (emergent, shrub, and/or forest Cowardin class): • Wetland has persistent, ungrazed vegetation > = 95% of area points = 5 <input type="checkbox"/> • Wetland has persistent, ungrazed vegetation > = 1/2 of area points = 3 <input checked="" type="checkbox"/> • Wetland has persistent, ungrazed vegetation > = 1/10 of area points = 1 <input type="checkbox"/> • Wetland has persistent, ungrazed vegetation < 1/10 of area points = 0 <input type="checkbox"/> Map of Cowardin vegetation classes	Figure <input type="checkbox"/> 3
D 1.4	Characteristics of seasonal ponding or inundation: <i>This is the area of the wetland that is ponded for at least 2 months, but dries out sometime during the year. Do not count the area that is permanently ponded. Estimate area as the average condition 5 out of 10 years.</i> • Area seasonally ponded is > 1/2 total area of wetland points = 4 <input checked="" type="checkbox"/> • Area seasonally ponded is > 1/4 total area of wetland points = 2 <input type="checkbox"/> • Area seasonally ponded is < 1/4 total area of wetland points = 0 <input type="checkbox"/> Map of Hydroperiods	Figure <input type="checkbox"/> 4
Total for D 1		<i>Add the points in the boxes above</i> 13
D 2	Does the wetland have the <u>opportunity</u> to improve water quality?	(see p. 44)
Answer YES if you know or believe there are pollutants in groundwater or surface water coming into the wetland that would otherwise reduce water quality in streams, lakes or groundwater downgradient from the wetland? <i>Note which of the following conditions provide the sources of pollutants. A unit may have pollutants coming from several sources, but any single source would qualify as opportunity.</i> <input type="checkbox"/> Grazing in the wetland or within 150 ft <input checked="" type="checkbox"/> Untreated stormwater discharges to wetland <input type="checkbox"/> Tilled fields or orchards within 150 ft. of wetland <input checked="" type="checkbox"/> A stream or culvert discharges into wetland that drains developed areas, residential areas, farmed fields, roads, or clear-cut logging <input checked="" type="checkbox"/> Residential, urban areas, golf courses are within 150 ft. of wetland <input type="checkbox"/> Wetland is fed by groundwater high in phosphorus or nitrogen <input type="checkbox"/> Other _____		Multiplier 2
<input checked="" type="checkbox"/> YES multiplier is 2 <input type="checkbox"/> NO multiplier is 1		
◆ TOTAL – Water Quality Functions Multiply the score from D1 by D2; then add score to table on p. 1		26
HYDROLOGIC FUNCTIONS – Indicators that wetland unit functions to reduce flooding and stream degradation.		
D 3	Does the wetland have the <u>potential</u> to reduce flooding and erosion?	(see p.46)
D 3.1	Characteristics of surface water flows out of the wetland unit • Unit is a depression with no surface water leaving it (no outlet) points = 4 <input type="checkbox"/> • Unit has an intermittently flowing, OR highly constricted permanently flowing outlet points = 2 <input checked="" type="checkbox"/> • Unit is a “flat” depression (Q.7 on key) or in the Flats class, with permanent surface outflow and no obvious natural outlet and/or outlet is a man-made ditch..... points = 1 <input type="checkbox"/> <i>(If ditch is not permanently flowing treat unit as “intermittently flowing”)</i> • Unit has an unconstricted, or slightly constricted, surface outlet (<i>permanently flowing</i>) points = 0	2
D 3.2	Depth of storage during wet periods. <i>Estimate the height of ponding above the bottom of the outlet. For units with no outlet measure from the surface of permanent water or deepest part (if dry).</i> • Marks of ponding are 3 ft. or more above the surface or bottom of the outlet points = 7 <input checked="" type="checkbox"/> • The wetland is a “headwater” wetland..... points = 5 <input type="checkbox"/> • Marks of ponding between 2 ft. to < 3 ft. from surface or bottom of outlet points = 5 <input type="checkbox"/> • Marks are at least 0.5 ft. to < 2 ft. from surface or bottom of outlet points = 3 <input type="checkbox"/> • Wetland is flat (yes to Q.2 or Q.7 on key) but has small depressions on the surface that trap water . points = 1 <input type="checkbox"/> • Marks of ponding less than 0.5 ft points = 0 <input type="checkbox"/>	7
D 3.3	Contribution of wetland unit to storage in the watershed: <i>Estimate the ratio of the area of upstream basin contributing surface water to the wetland to the area of the wetland unit itself.</i> • The area of the basin is less than 10 times the area of unit..... points = 5 <input type="checkbox"/> • The area of the basin is 10 to 100 times the area of the unit..... points = 3 <input checked="" type="checkbox"/> • The area of the basin is more than 100 times the area of the unit points = 0 <input type="checkbox"/> • Entire unit is in the FLATS class points = 5 <input type="checkbox"/>	3
Total for D 3		<i>Add the points in the boxes above</i> 12

D 4	<p>Does the wetland have the <u>opportunity</u> to reduce flooding and erosion?</p> <p>Answer YES if the unit is in a location in the watershed where the flood storage, or reduction in water velocity, it provides helps protect downstream property and aquatic resources from flooding or excessive and/or erosive flows. Answer NO if the water coming into the wetland is controlled by a structure such as flood gate, tide gate, flap valve, reservoir etc. OR you estimate that more than 90% of the water in the wetland is from groundwater in areas where damaging groundwater flooding does not occur. <i>Note which of the following indicators of opportunity apply.</i></p> <p><input type="checkbox"/> Wetland is in a headwater of a river or stream that has flooding problems.</p> <p><input checked="" type="checkbox"/> Wetland drains to a river or stream that has flooding problems</p> <p><input type="checkbox"/> Wetland has no outlet and impounds surface runoff water that might otherwise flow into a river or stream that has flooding problems</p> <p><input type="checkbox"/> Other _____</p> <p><input checked="" type="checkbox"/> YES multiplier is 2 <input type="checkbox"/> NO multiplier is 1</p>	<p>(see p. 49)</p> <p>Multiplier</p> <p>2</p>
◆	<p>TOTAL – Hydrologic Functions Multiply the score from D3 by D4; then <i>add score to table on p. 1</i></p>	<p><u>24</u></p>

Comments: Wetland rated by visual observations from outside property due to lack of ROE.

These questions apply to wetlands of all HGM classes.		Points																
HABITAT FUNCTIONS – Indicators that wetland functions to provide important habitat.		(only 1 score per box)																
H 1	Does the wetland have the potential to provide habitat for many species?																	
H 1.1	<p>Vegetation structure (see P. 72): Check the types of vegetation classes present (as defined by Cowardin) – Size threshold for each class is 1/4 acre or more than 10% of the area if unit is smaller than 2.5 acres.</p> <p><input checked="" type="checkbox"/> Aquatic Bed <input checked="" type="checkbox"/> Emergent plants <input checked="" type="checkbox"/> Scrub/shrub (areas where shrubs have > 30% cover) <input checked="" type="checkbox"/> Forested (areas where trees have > 30% cover)</p> <p>If the unit has a forested class check if: <input type="checkbox"/> The forested class has 3 out of 5 strata (canopy, sub-canopy, shrubs, herbaceous, moss/ground-cover) that each cover 20% within the forested polygon.</p> <p>Add the number of vegetation types that qualify. If you have:</p> <table border="0"> <tr> <td>4 structures or more..... points = 4</td> <td><input checked="" type="checkbox"/></td> <td>Map of Cowardin vegetation classes</td> <td></td> </tr> <tr> <td>3 structures..... points = 2</td> <td><input type="checkbox"/></td> <td></td> <td><input type="checkbox"/></td> </tr> <tr> <td>2 structures..... points = 1</td> <td><input type="checkbox"/></td> <td></td> <td><input type="checkbox"/></td> </tr> <tr> <td>1 structure..... points = 0</td> <td><input type="checkbox"/></td> <td></td> <td><input type="checkbox"/></td> </tr> </table>	4 structures or more..... points = 4	<input checked="" type="checkbox"/>	Map of Cowardin vegetation classes		3 structures..... points = 2	<input type="checkbox"/>		<input type="checkbox"/>	2 structures..... points = 1	<input type="checkbox"/>		<input type="checkbox"/>	1 structure..... points = 0	<input type="checkbox"/>		<input type="checkbox"/>	<p>Figure <input type="checkbox"/></p> <p>4</p>
4 structures or more..... points = 4	<input checked="" type="checkbox"/>	Map of Cowardin vegetation classes																
3 structures..... points = 2	<input type="checkbox"/>		<input type="checkbox"/>															
2 structures..... points = 1	<input type="checkbox"/>		<input type="checkbox"/>															
1 structure..... points = 0	<input type="checkbox"/>		<input type="checkbox"/>															
H 1.2	<p>Hydroperiods (see p.73): Check the types of water regimes (hydroperiods) present within the wetland. The water regime has to cover more than 10% of the wetland or 1/4 acre to count (see text for descriptions of hydroperiods).</p> <table border="0"> <tr> <td><input type="checkbox"/> Permanently flooded or inundated</td> <td>4 or more types present</td> <td>points = 3</td> <td><input checked="" type="checkbox"/></td> </tr> <tr> <td><input checked="" type="checkbox"/> Seasonally flooded or inundated</td> <td>3 or more types present</td> <td>points = 2</td> <td><input type="checkbox"/></td> </tr> <tr> <td><input checked="" type="checkbox"/> Occasionally flooded or inundated</td> <td>2 types present</td> <td>points = 1</td> <td><input type="checkbox"/></td> </tr> <tr> <td><input checked="" type="checkbox"/> Saturated only</td> <td>1 type present</td> <td>points = 0</td> <td><input type="checkbox"/></td> </tr> </table> <p><input checked="" type="checkbox"/> Permanently flowing stream or river in, or adjacent to, the wetland <input checked="" type="checkbox"/> Seasonally flowing stream in, or adjacent to, the wetland</p> <p><input checked="" type="checkbox"/> Lake-fringe wetland..... = 2 points <input type="checkbox"/> Freshwater tidal wetland..... = 2 points</p> <p style="text-align: right;">Map of hydroperiods</p>	<input type="checkbox"/> Permanently flooded or inundated	4 or more types present	points = 3	<input checked="" type="checkbox"/>	<input checked="" type="checkbox"/> Seasonally flooded or inundated	3 or more types present	points = 2	<input type="checkbox"/>	<input checked="" type="checkbox"/> Occasionally flooded or inundated	2 types present	points = 1	<input type="checkbox"/>	<input checked="" type="checkbox"/> Saturated only	1 type present	points = 0	<input type="checkbox"/>	<p>Figure <input type="checkbox"/></p> <p>3</p>
<input type="checkbox"/> Permanently flooded or inundated	4 or more types present	points = 3	<input checked="" type="checkbox"/>															
<input checked="" type="checkbox"/> Seasonally flooded or inundated	3 or more types present	points = 2	<input type="checkbox"/>															
<input checked="" type="checkbox"/> Occasionally flooded or inundated	2 types present	points = 1	<input type="checkbox"/>															
<input checked="" type="checkbox"/> Saturated only	1 type present	points = 0	<input type="checkbox"/>															
H 1.3	<p>Richness of Plant Species (see p. 75): Count the number of plant species in the wetland that cover at least 10 ft² (different patches of the same species can be combined to meet the size threshold) You do not have to name the species. Do not include Eurasian Milfoil, reed canarygrass, purple loosestrife, Canadian Thistle.</p> <p>If you counted:</p> <table border="0"> <tr> <td>> 19 species..... points = 2</td> <td><input checked="" type="checkbox"/></td> </tr> <tr> <td>5 – 19 species..... points = 1</td> <td><input type="checkbox"/></td> </tr> <tr> <td>< 5 species..... points = 0</td> <td><input type="checkbox"/></td> </tr> </table> <p>List species below if you want to: _____</p>	> 19 species..... points = 2	<input checked="" type="checkbox"/>	5 – 19 species..... points = 1	<input type="checkbox"/>	< 5 species..... points = 0	<input type="checkbox"/>	<p>2</p>										
> 19 species..... points = 2	<input checked="" type="checkbox"/>																	
5 – 19 species..... points = 1	<input type="checkbox"/>																	
< 5 species..... points = 0	<input type="checkbox"/>																	
H 1.4	<p>Interspersion of Habitats (see p. 76): Decided from the diagrams below whether interspersion between Cowardin vegetation (described in H1.1), or the classes and unvegetated areas (can include open water or mudflats) is high, medium, low, or none.</p> <div style="text-align: center;"> <p>None = 0 points Low = 1 point Moderate = 2 points</p> <p>High = 3 points [riparian braided channels]</p> </div> <p>Note: If you have 4 or more classes or 3 vegetation classes and open water, the rating is always “high”. Use map of Cowardin classes.</p>	<p>Figure <input type="checkbox"/></p> <p>3</p>																
H 1.5	<p>Special Habitat Features (see p. 77): Check the habitat features that are present in the wetland. The number of checks is the number of points you put into the next column.</p> <p><input checked="" type="checkbox"/> Large, downed, woody debris within the wetland (> 4 in. diameter and 6 ft. long) <input checked="" type="checkbox"/> Standing snags (diameter at the bottom > 4 inches) in the wetland <input type="checkbox"/> Undercut banks are present for at least 6.6 ft. (2m) and/or overhanging vegetation extends at least 3.3 ft. (1m) over a stream (or ditch) in, or contiguous with the unit, for at least 33 ft. (10m) <input checked="" type="checkbox"/> Stable steep banks of fine material that might be used by beaver or muskrat for denning (> 30 degree slope) OR signs of recent beaver activity are present (cut shrubs or trees that have not yet turned grey/brown) <input checked="" type="checkbox"/> At least 1/4 acre of thin-stemmed persistent vegetation or woody branches are present in areas that are permanently or seasonally inundated (structures for egg-laying by amphibians) <input type="checkbox"/> Invasive plants cover less than 25% of the wetland area in each stratum of plants</p> <p>NOTE: The 20% stated in early printings of the manual on page 78 is an error.</p>	<p>4</p>																
H 1 TOTAL Score – potential for providing habitat		<p>Add the points in the column above</p> <p>16</p>																

H 2	Does the wetland have the <u>opportunity</u> to provide habitat for many species?	(only 1 score per box)
	<p>H 2.1 <u>Buffers</u> (see P. 80): Choose the description that best represents condition of buffer of wetland unit. The highest scoring criterion that applies to the wetland is to be used in the rating. See text for definition of "undisturbed".</p> <p><input type="checkbox"/> 100m (330 ft) of relatively undisturbed vegetated areas, rocky areas, or open water > 95% of circumference. No structures are within the undisturbed part of buffer (relatively undisturbed also means no grazing, no landscaping, no daily human use)..... points = 5</p> <p><input type="checkbox"/> 100m (330 ft) of relatively undisturbed vegetated areas, rocky areas, or open water > 50% circumference points = 4</p> <p><input type="checkbox"/> 50m (170 ft) of relatively undisturbed vegetated areas, rocky areas, or open water > 95% circumference points = 4</p> <p><input type="checkbox"/> 100m (330 ft) of relatively undisturbed vegetated areas, rocky areas, or open water > 25% circumference points = 3</p> <p><input type="checkbox"/> 50m (170 ft) of relatively undisturbed vegetated areas, rocky areas, or open water for > 50% circumference points = 3</p> <p>If buffer does not meet any of the criteria above:</p> <p><input type="checkbox"/> No paved areas (except paved trails) or buildings within 25m (80 ft) of wetland > 95% circumference. Light to moderate grazing or lawns are OK points = 2</p> <p><input type="checkbox"/> No paved areas of buildings within 50m of wetland for > 50% circumference. Light to moderate grazing or lawns are OK points = 2</p> <p><input type="checkbox"/> Heavy grazing in buffer points = 1</p> <p><input type="checkbox"/> Vegetated buffers are < 2m wide (6.6 ft) for more than 95% circumference (e.g. tilled fields, paving, basalt bedrock extend to edge of wetland) points = 0</p> <p><input checked="" type="checkbox"/> Buffer does not meet any of the criteria above points = 1</p> <p style="text-align: right;">Arial photo showing buffers</p>	<p>Figure <input type="checkbox"/></p> <p style="text-align: right;">1</p>
	<p>H 2.2 <u>Corridors and Connections</u> (see p. 81)</p> <p>H 2.2.1 Is the wetland part of a relatively undisturbed and unbroken vegetated corridor (either riparian or upland) that is at least 150 ft. wide, has at least a 30% cover of shrubs, forest or native undisturbed prairie, that connects to estuaries, other wetlands or undisturbed uplands that are at least 250 acres in size? (<i>Dams in riparian corridors, heavily used gravel roads, paved roads, are considered breaks in the corridor.</i>)</p> <p style="text-align: center;"><input type="checkbox"/> YES = 4 points (go to H 2.3) <input type="checkbox"/> NO = go to H 2.2.2</p> <p>H. 2.2.2 Is the wetland part of a relatively undisturbed and unbroken vegetated corridor (either riparian or upland) that is at least 50 ft. wide, has at least 30% cover of shrubs or forest, and connects to estuaries, other wetlands or undisturbed uplands that are at least 25 acres in size? OR a Lake-fringe wetland, if it does not have an undisturbed corridor as in the question above?</p> <p style="text-align: center;"><input checked="" type="checkbox"/> YES = 2 points (go to H 2.3) <input type="checkbox"/> NO = go to H 2.2.3</p> <p>H. 2.2.3 Is the wetland:</p> <ul style="list-style-type: none"> • Within 5 mi (8km) of a brackish or salt water estuary OR • Within 3 miles of a large field or pasture (> 40 acres) OR • Within 1 mile of a lake greater than 20 acres? <p style="text-align: right;"><input type="checkbox"/> YES = 1 point <input checked="" type="checkbox"/> NO = 0 points</p>	<p style="text-align: right;">0</p>

Comments: Wetland rated by visual observations from outside property due to lack of ROE.

	<p>H 2.3 <u>Near or adjacent to other priority habitats listed by WDFW</u> (see p. 82): <i>(see new and complete descriptions of WDFW priority habitats, and the counties in which they can be found, in the PHS report http://wdfw.wa.gov/hab/phslist.htm)</i> Which of the following priority habitats are within 330 ft. (100m) of the wetland unit? NOTE: <i>the connections do not have to be relatively undisturbed.</i></p> <p><input type="checkbox"/> Aspen Stands: Pure or mixed stands of aspen greater than 0.4 ha (1 acre).</p> <p><input checked="" type="checkbox"/> Biodiversity Areas and Corridors: Areas of habitat that are relatively important to various species of native fish and wildlife <i>(full descriptions in WDFW PHS report p. 152).</i></p> <p><input type="checkbox"/> Herbaceous Balds: Variable size patches of grass and forbs on shallow soils over bedrock.</p> <p><input type="checkbox"/> Old-growth/Mature forests: (Old-growth west of Cascade crest) Stands of at least 2 tree species, forming a multi-layered canopy with occasional small openings; with at least 20 trees/ha (8 trees/acre) > 81 cm (32 in) dbh or > 200 years of age. (Mature forests) Stands with average diameters exceeding 53 cm (21 in) dbh; crown cover may be less than 100%; decay, decadence, numbers of snags, and quantity of large downed material is generally less than that found in old-growth; 80 - 200 years old west of the Cascade crest.</p> <p><input type="checkbox"/> Oregon white Oak: Woodlands Stands of pure oak or oak/conifer associations where canopy coverage of the oak component is important <i>(full descriptions in WDFW PHS report p. 158).</i></p> <p><input checked="" type="checkbox"/> Riparian: The area adjacent to aquatic systems with flowing water that contains elements of both aquatic and terrestrial ecosystems which mutually influence each other.</p> <p><input type="checkbox"/> Westside Prairies: Herbaceous, non-forested plant communities that can either take the form of a dry prairie or a wet prairie <i>(full descriptions in WDFW PHS report p. 161).</i></p> <p><input checked="" type="checkbox"/> Instream: The combination of physical, biological, and chemical processes and conditions that interact to provide functional life history requirements for instream fish and wildlife resources.</p> <p><input type="checkbox"/> Nearshore: Relatively undisturbed nearshore habitats. These include Coastal Nearshore, Open Coast Nearshore, and Puget Sound Nearshore. <i>(full descriptions of habitats and the definition of relatively undisturbed are in WDFW report: pp. 167-169 and glossary in Appendix A).</i></p> <p><input type="checkbox"/> Caves: A naturally occurring cavity, recess, void, or system of interconnected passages under the earth in soils, rock, ice, or other geological formations and is large enough to contain a human.</p> <p><input type="checkbox"/> Cliffs: Greater than 7.6 m (25 ft) high and occurring below 5000 ft.</p> <p><input type="checkbox"/> Talus: Homogenous areas of rock rubble ranging in average size 0.15 - 2.0 m (0.5 - 6.5 ft), composed of basalt, andesite, and/or sedimentary rock, including riprap slides and mine tailings. May be associated with cliffs.</p> <p><input checked="" type="checkbox"/> Snags and Logs: Trees are considered snags if they are dead or dying and exhibit sufficient decay characteristics to enable cavity excavation/use by wildlife. Priority snags have a diameter at breast height of > 51 cm (20 in) in western Washington and are > 2 m (6.5 ft) in height. Priority logs are > 30 cm (12 in) in diameter at the largest end, and > 6 m (20 ft) long.</p> <p style="text-align: right;">If wetland has 3 or more priority habitats = 4 points If wetland has 2 priority habitats = 3 points If wetland has 1 priority habitat = 1 point No habitats = 0 points</p> <p>Note: All vegetated wetlands are by definition a priority habitat but are not included in this list. Nearby wetlands are addressed in question H 2.4)</p>	4
	<p>H 2.4 <u>Wetland Landscape:</u> <i>Choose the one description of the landscape around the wetland that best fits (see p. 84)</i></p> <ul style="list-style-type: none"> • There are at least 3 other wetlands within 1/2 mile, and the connections between them are relatively undisturbed (light grazing between wetlands OK, as is lake shore with some boating, but connections should NOT be bisected by paved roads, fill, fields, or other development.... points = 5 <input type="checkbox"/> • The wetland is Lake-fringe on a lake with little disturbance and there are 3 other lake-fringe wetlands within 1/2 mile points = 5 <input type="checkbox"/> • There are at least 3 other wetlands within 1/2 mile, BUT the connections between them are disturbed. points = 3 <input type="checkbox"/> • The wetland fringe on a lake with disturbance and there are 3 other lake-fringe wetlands within 1/2 mile points = 3 <input checked="" type="checkbox"/> • There is at least 1 wetland within 1/2 mile points = 2 <input type="checkbox"/> • There are no wetlands within 1/2 mile..... points = 0 <input type="checkbox"/> 	3
H 2 TOTAL Score – opportunity for providing habitat <i>Add the scores from H2.1, H2.2, H2.3, H2.4</i>		8
<i>TOTAL for H 1 from page 8</i>		16
◆	Total Score for Habitat Functions <i>Add the points for H 1 and H 2; then record the result on p. 1</i>	24

Comments: Wetland rated by visual observations from outside property due to lack of ROE.

CATEGORIZATION BASED ON SPECIAL CHARACTERISTICS

Please determine if the wetland meets the attributes described below and circle the appropriate answers and Category.

Wetland Type – Check off any criteria that apply to the wetland. Circle the Category when the appropriate criteria are met.	
SC1	<p>Estuarine wetlands? (see p.86)</p> <p>Does the wetland unit meet the following criteria for Estuarine wetlands?</p> <p><input type="checkbox"/> The dominant water regime is tidal, <input type="checkbox"/> Vegetated, and <input type="checkbox"/> With a salinity greater than 0.5 ppt.</p> <p style="text-align: center;"><input type="checkbox"/> YES = Go to SC 1.1 <input checked="" type="checkbox"/> NO</p>
	<p>SC 1.1 Is the wetland unit within a National Wildlife Refuge, National Park, National Estuary Reserve, Natural Area Preserve, State Park or Educational, Environmental, or Scientific Reserve designated under WAC 332-30-151? <input type="checkbox"/> YES = Category I <input type="checkbox"/> NO = go to SC 1.2</p>
	<p>SC 1.2 Is the wetland at least 1 acre in size and meets at least two of the following conditions?</p> <p style="text-align: center;"><input type="checkbox"/> YES = Category I <input type="checkbox"/> NO = Category II</p> <p><input type="checkbox"/> The wetland is relatively undisturbed (has no diking, ditching, filling, cultivation, grazing, and has less than 10% cover of non-native plant species. If the non-native <i>Spartina</i> spp. are only species that cover more than 10% of the wetland, then the wetland should be given a dual rating (I/II). The area of <i>Spartina</i> would be rated a Category II while the relatively undisturbed upper marsh with native species would be a Category I. Do not, however, exclude the area of <i>Spartina</i> in determining the size threshold of 1 acre.</p> <p><input type="checkbox"/> At least 3/4 of the landward edge of the wetland has a 100 ft. buffer of shrub, forest, or un-grazed or un-mowed grassland</p> <p><input type="checkbox"/> The wetland has at least 2 of the following features: tidal channels, depressions with open water, or contiguous freshwater wetlands.</p>
SC2	<p>Natural Heritage Wetlands (see p. 87)</p> <p>Natural Heritage wetlands have been identified by the Washington Natural Heritage Program/DNR as either high quality undisturbed wetlands or wetlands that support state Threatened, Endangered, or Sensitive plant species.</p> <p>SC 2.1 Is the wetland being rated in a Section/Township/Range that contains a natural heritage wetland? (This question is used to screen out most sites before you need to contact WNHP/DNR.)</p> <p style="text-align: center;"><input type="checkbox"/> S/T/R information from Appendix D <input type="checkbox"/> or accessed from WNHP/DNR web site</p> <p style="text-align: center;"><input type="checkbox"/> YES Contact WNHP/DNR (see p. 79) and go to SC 2.2 <input checked="" type="checkbox"/> NO</p> <p>SC 2.2 Has DNR identified the wetland as a high quality undisturbed wetland or as a site with state threatened or endangered plant species?</p> <p style="text-align: center;"><input type="checkbox"/> YES = Category 1 <input checked="" type="checkbox"/> NO not a Heritage Wetland</p>
SC3	<p>Bogs (see p. 87)</p> <p>Does the wetland (or any part of the unit) meet both the criteria for soils and vegetation in bogs? Use the key below to identify if the wetland is a bog. <i>If you answer yes you will still need to rate the wetland based on its function.</i></p> <p>1. Does the unit have organic soil horizons (i.e. layers of organic soil), either peats or mucks, that compose 16 inches or more of the first 32 inches of soil profile? (See Appendix B for a field key to identify organic soils)? <input type="checkbox"/> YES = go to question 3 <input checked="" type="checkbox"/> NO = go to question 2</p> <p>2. Does the wetland have organic soils, either peats or mucks that are less than 16 inches deep over bedrock, or an impermeable hardpan such as clay or volcanic ash, or that are floating on a lake or pond? <input type="checkbox"/> YES = go to question 3 <input checked="" type="checkbox"/> NO = is not a bog for purpose of rating</p> <p>3. Does the unit have more than 70% cover of mosses at ground level, AND other plants, if present, consist of the “bog” species listed in Table 3 as a significant component of the vegetation (more than 30% of the total shrub and herbaceous cover consists of species in Table 3)?</p> <p style="text-align: center;"><input type="checkbox"/> YES = Is a bog for purpose of rating <input checked="" type="checkbox"/> NO = go to question 4</p> <p>NOTE: If you are uncertain about the extent of mosses in the understory you may substitute that criterion by measuring the pH of the water that seeps into a hole dug at least 16” deep. If the pH is less than 5.0 and the “bog” plant species in Table 3 are present, the wetland is a bog.</p> <p>4. Is the unit forested (> 30% cover) with sitka spruce, subalpine fir, western red cedar, western hemlock, lodgepole pine, quaking aspen, Englemann’s spruce, or western white pine. WITH any of the species (or combination of species) on the bog species plant list in Table 3 as a significant component of the ground cover (> 30% coverage of the total shrub/herbaceous cover)?</p> <p style="text-align: center;"><input type="checkbox"/> YES = Category I <input checked="" type="checkbox"/> NO = Is not a bog for purpose of rating</p>
	<p>Cat. I <input type="checkbox"/></p>

SC4	<p>Forested Wetlands (see p. 90)</p> <p>Does the wetland have at least 1 acre of forest that meet one of these criteria for the Department of Fish and Wildlife's forests as priority habitats? <i>If you answer yes you will still need to rate the wetland based on its function.</i></p> <p><input type="checkbox"/> Old-growth forests: (west of Cascade Crest) Stands of at least two three species forming a multi-layered canopy with occasional small openings; with at least 8 trees/acre (20 trees/hectare) that are at least 200 years of age OR have a diameter at breast height (dbh) of 32 inches (81 cm or more).</p> <p>NOTE: The criterion for dbh is based on measurements for upland forests. Two-hundred year old trees in wetlands will often have a smaller dbh because their growth rates are often slower. The DFW criterion is and "OR" so old-growth forests do not necessarily have to have trees of this diameter.</p> <p><input type="checkbox"/> Mature forests: (west of the Cascade Crest) Stands where the largest trees are 80 – 200 years old OR have an average diameters (dbh) exceeding 21 inches (53 cm); crown cover may be less than 100%; decay, decadence, numbers of snags, and quantity of large downed material is generally less than that found in old-growth.</p> <p><input type="checkbox"/> YES = Category I <input checked="" type="checkbox"/> NO = not a forested wetland with special characteristics</p>	<p>Cat. I</p> <p><input type="checkbox"/></p>
SC5	<p>Wetlands in Coastal Lagoons (see p. 91)</p> <p>Does the wetland meet all of the following criteria of a wetland in a coastal lagoon?</p> <p><input type="checkbox"/> The wetland lies in a depression adjacent to marine waters that is wholly or partially separated from marine waters by sandbanks, gravel banks, shingle, or, less frequently, rocks.</p> <p><input type="checkbox"/> The lagoon in which the wetland is located contains surface water that is saline or brackish (> 0.5 ppt) during most of the year in at least a portion of the lagoon (<i>needs to be measured near the bottom.</i>)</p> <p><input type="checkbox"/> YES = Go to SC 5.1 <input checked="" type="checkbox"/> NO not a wetland in a coastal lagoon</p> <p>SC 5.1 Does the wetland meet all of the following three conditions?</p> <p><input type="checkbox"/> The wetland is relatively undisturbed (has no diking, ditching, filling, cultivation, grazing) and has less than 20% cover of invasive plant species (see list of invasive species on p. 74).</p> <p><input type="checkbox"/> At least 3/4 of the landward edge of the wetland has a 100 ft. buffer of shrub, forest, or un-grazed or un-mowed grassland.</p> <p><input type="checkbox"/> The wetland is larger than 1/10 acre (4350 square ft.)</p> <p><input type="checkbox"/> YES = Category I <input type="checkbox"/> NO = Category II</p>	<p>Cat. I</p> <p><input type="checkbox"/></p> <p>Cat. II</p> <p><input type="checkbox"/></p>
SC6	<p>Interdunal Wetlands (see p. 93)</p> <p>Is the wetland west of the 1889 line (also called the Western Boundary of Upland Ownership or WBUO)?</p> <p><input type="checkbox"/> YES = Go to SC 6.1 <input checked="" type="checkbox"/> NO not an interdunal wetland for rating</p> <p><i>If you answer yes you will still need to rate the wetland based on its functions.</i></p> <p>In practical terms that means the following geographic areas:</p> <ul style="list-style-type: none"> • Long Beach Peninsula -- lands west of SR 103 • Grayland-Westport -- lands west of SR 105 • Ocean Shores-Copalis – lands west of SR 115 and SR 109 <p>SC 6.1 Is the wetland one acre or larger, or is it in a mosaic of wetlands that is one acre or larger?</p> <p><input type="checkbox"/> YES = Category II <input type="checkbox"/> NO = go to SC 6.2</p> <p>SC 6.2 Is the wetland between 0.1 and 1 acre, or is it in a mosaic of wetlands that is between 0.1 and 1 acre?</p> <p><input type="checkbox"/> YES = Category III</p>	<p>Cat. II</p> <p><input type="checkbox"/></p> <p>Cat. III</p> <p><input type="checkbox"/></p>
◆	<p>Category of wetland based on Special Characteristics</p> <p>Choose the "highest" rating if wetland falls into several categories, and record on p. 1.</p> <p>If you answered NO for all types enter "Not Applicable" on p. 1</p>	<p>NA</p>

Comments:

WETLAND RATING FORM – WESTERN WASHINGTON
 Version 2 – Updated July 2006 to increase accuracy and reproducibility among users
 Updated Oct. 2008 with the new WDFW definitions for priority habitats

Name of wetland (if known): Kelsey West Tributary Stream

Date of site visit: February 6, 2013

Rated by: C. Douglas & J. Pursley Trained by Ecology? Yes No

Date of training: May 2007

SEC: 28 TOWNSHP: 24N RNGE: 5E

Is S/T/R in Appendix D? Yes No

Map of wetland unit: Figure _____ Estimated size _____

SUMMARY OF RATING

Category based on FUNCTIONS provided by wetland: I II III IV

Category I =	Score > 70
Category II =	Score 51 - 69
Category III =	Score 30 – 50
Category IV =	Score < 30

Score for Water Quality Functions	16
Score for Hydrologic Functions	18
Score for Habitat Functions	16
TOTAL Score for Functions	50

Category based on SPECIAL CHARACTERISTICS of Wetland I II Does not apply

Final Category (choose the “highest” category from above”)

III

Summary of basic information about the wetland unit.

Wetland Unit has Special Characteristics		Wetland HGM Class used for Rating	
Estuarine	<input type="checkbox"/>	Depressional	<input type="checkbox"/>
Natural Heritage Wetland	<input type="checkbox"/>	Riverine	<input checked="" type="checkbox"/>
Bog	<input type="checkbox"/>	Lake-fringe	<input type="checkbox"/>
Mature Forest	<input type="checkbox"/>	Slope	<input type="checkbox"/>
Old Growth Forest	<input type="checkbox"/>	Flats	<input type="checkbox"/>
Coastal Lagoon	<input type="checkbox"/>	Freshwater Tidal	<input type="checkbox"/>
Interdunal	<input type="checkbox"/>		<input type="checkbox"/>
None of the above	<input checked="" type="checkbox"/>	Check if unit has multiple HGM classes present	<input type="checkbox"/>

Does the wetland being rated meet any of the criteria below? If you answer YES to any of the questions below you will need to protect the wetland according to the regulations regarding the special characteristics found in the wetland.

Check List for Wetlands that Need Additional Protection (in addition to the protection recommended for its category)	YES	NO
SP1. <i>Has the wetland unit been documented as a habitat for any Federally listed Threatened or Endangered animal or plant species (T/E species)?</i> For the purposes of this rating system, “documented” means the wetland is on the appropriate state or federal database.	<input type="checkbox"/>	<input checked="" type="checkbox"/>
SP2. <i>Has the wetland unit been documented as habitat for any State listed Threatened or Endangered animal species?</i> For the purposes of this rating system, “documented” means the wetland is on the appropriate state database. Note: Wetlands with State listed plant species are categorized as Category 1 Natural Heritage Wetlands (see p. 19 of data form).	<input type="checkbox"/>	<input checked="" type="checkbox"/>
SP3. <i>Does the wetland unit contain individuals of Priority species listed by the WDFW for the state?</i>	<input type="checkbox"/>	<input checked="" type="checkbox"/>
SP4. <i>Does the wetland unit have a local significance in addition to its functions?</i> For example, the wetland has been identified in the Shoreline Master Program, the Critical Areas Ordinance, or in a local management plan as having special significance.	<input type="checkbox"/>	<input checked="" type="checkbox"/>

To complete the next part of the data sheet you will need to determine the Hydrogeomorphic Class of the wetland being rated.

The hydrogeomorphic classification groups wetlands in to those that function in similar ways. This simplifies the questions needed to answer how well the wetland functions. The Hydrogeomorphic Class of a wetland can be determined using the key below. See p. 24 for more detailed instructions on classifying wetlands.

Classification of Vegetated Wetlands for Western Washington

If the hydrologic criteria listed in each question do not apply to the entire unit being rated, you probably have a unit with multiple HGM classes. In this case, identify which hydrologic criteria in questions 1-7 apply, and go to Question 8.

1. Are the water levels in the entire unit usually controlled by tides (i.e. except during floods)?
 NO – go to 2 YES – the wetland class is **Tidal Fringe**
 If yes, is the salinity of the water during periods of annual low flow below 0.5 ppt (parts per thousand)?
 YES – **Freshwater Tidal Fringe** NO – **Saltwater Tidal Fringe (Estuarine)**
*If your wetland can be classified as a Freshwater Tidal Fringe use the forms for **Riverine** wetlands. If it is a Saltwater Tidal Fringe it is rated as an **Estuarine** wetland. Wetlands that were call estuarine in the first and second editions of the rating system are called Salt Water Tidal Fringe in the Hydrogeomorphic Classification. Estuarine wetlands were categorized separately in the earlier editions, and this separation is being kept in this revision. To maintain consistency between editions, the term “Estuarine” wetland is kept. Please note, however, that the characteristics that define Category I and II estuarine wetlands have changed (see p. _____).*
-
2. The entire wetland unit is flat and precipitation is only source (>90%) of water to it. Groundwater and surface water runoff are NOT sources of water to the unit.
 NO – go to 3 YES – The wetland class is **Flats**
 If your wetland can be classified as a “Flats” wetland, use the form for **Depressional** wetlands.
-
3. Does the entire wetland meet both of the following criteria?
 The vegetated part of the wetland is on the shores of a body of permanent open water (without any vegetation on the surface) where at least 20 acres (8ha) in size;
 At least 30% of the open water area is deeper than 6.6 (2 m)?
 NO – go to 4 YES – The wetland class is **Lake-fringe (Lacustrine Fringe)**
-
4. Does the entire wetland meet all of the following criteria?
 The wetland is on a slope (*slope can be very gradual*).
 The water flows through the wetland in one direction (unidirectional) and usually comes from seeps. It may flow subsurface, as sheetflow, or in a swale without distinct banks.
 The water leaves the wetland **without being impounded**?
 NOTE: *Surface water does not pond in these types of wetlands except occasionally in very small and shallow depressions or behind hummocks (depressions are usually <3 ft diameter and less than 1 foot deep).*
 NO – go to 5 YES – The wetland class is **Slope**
-
5. Does the entire wetland meet all of the following criteria?
 The unit is in a valley or stream channel where it gets inundated by overbank flooding from that stream or river.
 The overbank flooding occurs at least once every two years.
 NOTE: *The riverine unit can contain depressions that are filled with water when the river is not flooding..*
 NO – go to 6 YES – The wetland class is **Riverine**
-
6. Is the entire wetland unit in a topographic depression in which water ponds, or is saturated to the surface, at some time of the year. This means that any outlet, if present is higher than the interior of the wetland.
 NO – go to 7 YES – The wetland class is **Depressional**
-
7. Is the entire wetland located in a very flat area with no obvious depression and no overbank flooding. The unit does not pond surface water more than a few inches. The unit seems to be maintained by high groundwater in the area. The wetland may be ditched, but has no obvious natural outlet.
 No – go to 8 YES – The wetland class is **Depressional**
-
8. Your wetland unit seems to be difficult to classify and probably contains several different HGM classes. For example, seeps at the base of a slope may grade into a riverine floodplain, or a small stream within a depressional wetland has a zone of flooding along its sides. GO BACK AND IDENTIFY WHICH OF THE HYDROLOGIC REGIMES DESCRIBED IN QUESTIONS 1-7 APPLY TO DIFFERENT AREAS IN THE UNIT (make a rough sketch to help you decide). Use the following table to identify the appropriate class to use for the rating system if you have several HGM classes present within your wetland. NOTE: Use this table only if the class that is recommended in the second column represents 10% or more of the total area of the wetland unit being rated. If the area of the class listed in column 2 is less than 10% of the unit, classify the wetland using the class that represents more than 90% of the total area.

HGM Classes within the wetland unit being rated	HGM Class to Use in Rating
Slope + Riverine	Riverine
Slope + Depressional	Depressional
Slope + Lake-fringe	Lake-fringe
Depressional + Riverine along stream within boundary	Depressional
Depressional + Lake-fringe	Depressional
Salt Water Tidal Fringe and any other class of freshwater wetland	Treat as ESTUARINE under wetlands with special characteristics

If you are unable still to determine which of the above criteria apply to your wetland, or you have more than 2 HGM classes within a wetland boundary, classify the wetland as **Depressional** for the rating.

R Riverine and Freshwater Tidal Fringe Wetlands		Points
WATER QUALITY FUNCTIONS – Indicators that wetland functions to improve water quality.		(only 1 score per box)
R 1	Does the wetland have the <u>potential</u> to improve water quality? (see p.52)	
	R 1.1 Area of surface depressions within the riverine wetland that can trap sediments during a flooding event: <ul style="list-style-type: none"> • Depressions cover > 3/4 area of wetland points = 8 <input type="checkbox"/> • Depressions cover > 1/2 area of wetland points = 4 <input type="checkbox"/> (If depressions > 1/2 of area of unit draw polygons on aerial photo or map) • Depressions present but cover < 1/2 area of wetland. points = 2 <input checked="" type="checkbox"/> • No depressions present points = 0 <input type="checkbox"/> 	Figure <input type="checkbox"/> 2
	R 1.2 Characteristics of the vegetation in the unit (areas with >90% cover at person height): <ul style="list-style-type: none"> • Trees or shrubs > 2/3 area of the unit points = 8 <input type="checkbox"/> • Trees or shrubs > 1/3 area of the wetland points = 6 <input checked="" type="checkbox"/> • Ungrazed, herbaceous plants > 2/3 area of unit points = 6 <input type="checkbox"/> • Ungrazed herbaceous plants > 1/3 area of unit points = 3 <input type="checkbox"/> • Trees, shrubs, and ungrazed herbaceous < 1/3 area of unit points = 0 <input type="checkbox"/> 	Figure <input type="checkbox"/> 6
Aerial photo or map showing polygons of different vegetation types		
Add the points in the boxes above		8
R 2	Does the wetland have the <u>opportunity</u> to improve water quality?	(see p. 53)
	Answer YES if you know or believe there are pollutants in groundwater or surface water coming into the wetland that would otherwise reduce water quality in streams, lakes or groundwater downgradient from the wetland. <i>Note which of the following conditions provide the sources of pollutants. A unit may have pollutants coming from several sources, but any single source would qualify as opportunity.</i> <ul style="list-style-type: none"> <input type="checkbox"/> Grazing in the wetland or within 150 ft <input checked="" type="checkbox"/> Untreated stormwater discharges to wetland <input checked="" type="checkbox"/> Tilled fields or orchards within 150 ft. of wetland <input checked="" type="checkbox"/> A stream or culvert discharges into wetland that drains developed areas, residential areas, farmed fields, roads, or clear-cut logging <input checked="" type="checkbox"/> Residential, urban areas, golf courses are within 150 ft. of wetland <input type="checkbox"/> The river or stream linked to the wetland has a contributing basin where human activities have raised levels of sediment, toxic compounds or nutrients in the river water above standards for water quality. <input type="checkbox"/> Other _____ 	Multiplier 2
YES multiplier is 2 NO multiplier is 1		
◆ TOTAL – Water Quality Functions Multiply the score from R1 by R2; then <i>add score to table on p. 1</i>		16
HYDROLOGIC FUNCTIONS – Indicators that wetland functions to reduce flooding and stream erosion.		
R 3	Does the wetland have the <u>potential</u> to reduce flooding and erosion?	(see p.54)
	R 3.1 Characteristics of the overbank storage the wetland provides: <i>Estimate the average width of the wetland perpendicular to the direction of the flow and the width of the stream or river channel (distance between banks). Calculate the ratio: (average width of unit) / (average width of stream between banks).</i> <ul style="list-style-type: none"> • If the ratio is more than 20 points = 9 <input type="checkbox"/> • If the ratio is between 10 – 20 points = 6 <input type="checkbox"/> • If the ratio is 5- <10 points = 4 <input type="checkbox"/> • If the ratio is 1- <5 points = 2 <input checked="" type="checkbox"/> • If the ratio is < 1 points = 1 <input type="checkbox"/> 	Figure <input type="checkbox"/> 2
	R 3.2 Characteristics of vegetation that slow down water velocities during floods: <i>Treat large woody debris as “forest or shrub”. Choose the points appropriate for the best description. (polygons need to have >90% cover at person height NOT Cowardin classes):</i> <ul style="list-style-type: none"> • Forest or shrub for > 1/3 area OR herbaceous plants > 2/3 area points = 7 <input checked="" type="checkbox"/> • Forest or shrub for > 1/10 area OR herbaceous plants > 1/3 area points = 4 <input type="checkbox"/> • Vegetation does not meet above criteria points = 0 <input type="checkbox"/> 	Figure <input type="checkbox"/> 7
Aerial photo or map showing polygons of different vegetation types		
Add the points in the boxes above		9
R 4	Does the wetland have the <u>opportunity</u> to reduce flooding and erosion?	(see p.57)
	Answer YES if the wetland is in a location in the watershed where the flood storage, or reduction in water velocity, it provides helps protect downstream property and aquatic resources from flooding or excessive and/or erosive flows. <i>Note which of the following conditions apply.</i> <ul style="list-style-type: none"> <input checked="" type="checkbox"/> There are human structures and activities downstream (roads, buildings, bridges, farms) that can be damaged by flooding. <input checked="" type="checkbox"/> There are natural resources downstream (e.g. salmon redds) that can be damaged by flooding <input type="checkbox"/> Other _____ 	Multiplier 2
(Answer NO if the major source of water to the wetland is controlled by a reservoir or the wetland is tidal fringe along the sides of a dike)		
<input checked="" type="checkbox"/> YES multiplier is 2 <input type="checkbox"/> NO multiplier is 1		
◆ TOTAL – Hydrologic Functions Multiply the score from R3 by R4; then <i>add score to table on p. 1</i>		18

Comments: _____

<i>These questions apply to wetlands of all HGM classes.</i>		Points (only 1 score per box)								
HABITAT FUNCTIONS – Indicators that wetland functions to provide important habitat.										
H 1	Does the wetland have the potential to provide habitat for many species?									
H 1.1	<p>Vegetation structure (see P. 72): Check the types of vegetation classes present (as defined by Cowardin) – Size threshold for each class is 1/4 acre or more than 10% of the area if unit is smaller than 2.5 acres.</p> <p><input type="checkbox"/> Aquatic Bed <input checked="" type="checkbox"/> Emergent plants <input checked="" type="checkbox"/> Scrub/shrub (areas where shrubs have > 30% cover) <input checked="" type="checkbox"/> Forested (areas where trees have > 30% cover)</p> <p>If the unit has a forested class check if: <input type="checkbox"/> The forested class has 3 out of 5 strata (canopy, sub-canopy, shrubs, herbaceous, moss/ground-cover) that each cover 20% within the forested polygon.</p> <p>Add the number of vegetation types that qualify. If you have: Map of Cowardin vegetation classes</p> <table style="width: 100%; border: none;"> <tr> <td style="width: 50%;">4 structures or more..... points = 4</td> <td style="width: 50%;">3 structures..... points = 2</td> </tr> <tr> <td>2 structures..... points = 1</td> <td>1 structure..... points = 0</td> </tr> </table>	4 structures or more..... points = 4	3 structures..... points = 2	2 structures..... points = 1	1 structure..... points = 0	<p>Figure <input type="checkbox"/></p> <p style="text-align: right;">2</p>				
4 structures or more..... points = 4	3 structures..... points = 2									
2 structures..... points = 1	1 structure..... points = 0									
H 1.2	<p>Hydroperiods (see p.73): Check the types of water regimes (hydroperiods) present within the wetland. The water regime has to cover more than 10% of the wetland or 1/4 acre to count (see text for descriptions of hydroperiods).</p> <table style="width: 100%; border: none;"> <tr> <td style="width: 50%;"><input type="checkbox"/> Permanently flooded or inundated</td> <td style="width: 50%;">4 or more types present points = 3</td> </tr> <tr> <td><input checked="" type="checkbox"/> Seasonally flooded or inundated</td> <td>3 or more types present points = 2</td> </tr> <tr> <td><input checked="" type="checkbox"/> Occasionally flooded or inundated</td> <td>2 types present points = 1</td> </tr> <tr> <td><input checked="" type="checkbox"/> Saturated only</td> <td>1 type present points = 0</td> </tr> </table> <p><input checked="" type="checkbox"/> Permanently flowing stream or river in, or adjacent to, the wetland <input type="checkbox"/> Seasonally flowing stream in, or adjacent to, the wetland</p> <p><input type="checkbox"/> Lake-fringe wetland..... = 2 points <input type="checkbox"/> Freshwater tidal wetland..... = 2 points</p> <p style="text-align: right;">Map of hydroperiods</p>	<input type="checkbox"/> Permanently flooded or inundated	4 or more types present points = 3	<input checked="" type="checkbox"/> Seasonally flooded or inundated	3 or more types present points = 2	<input checked="" type="checkbox"/> Occasionally flooded or inundated	2 types present points = 1	<input checked="" type="checkbox"/> Saturated only	1 type present points = 0	<p>Figure <input type="checkbox"/></p> <p style="text-align: right;">2</p>
<input type="checkbox"/> Permanently flooded or inundated	4 or more types present points = 3									
<input checked="" type="checkbox"/> Seasonally flooded or inundated	3 or more types present points = 2									
<input checked="" type="checkbox"/> Occasionally flooded or inundated	2 types present points = 1									
<input checked="" type="checkbox"/> Saturated only	1 type present points = 0									
H 1.3	<p>Richness of Plant Species (see p. 75): Count the number of plant species in the wetland that cover at least 10 ft² (different patches of the same species can be combined to meet the size threshold) You do not have to name the species. Do not include Eurasian Milfoil, reed canarygrass, purple loosestrife, Canadian Thistle.</p> <p>If you counted: > 19 species points = 2 5 – 19 species..... points = 1 < 5 species points = 0</p> <p>List species below if you want to: _____</p>	<p style="text-align: right;">1</p>								
H 1.4	<p>Interspersion of Habitats (see p. 76): Decided from the diagrams below whether interspersion between Cowardin vegetation (described in H1.1), or the classes and unvegetated areas (can include open water or mudflats) is high, medium, low, or none.</p> <div style="text-align: center;"> <p>None = 0 points Low = 1 point Moderate = 2 points</p> <p>High = 3 points [riparian braided channels]</p> </div> <p>Note: If you have 4 or more classes or 3 vegetation classes and open water, the rating is always “high”.</p> <p style="text-align: right;">Use map of Cowardin classes.</p>	<p>Figure <input type="checkbox"/></p> <p style="text-align: right;">3</p>								
H 1.5	<p>Special Habitat Features (see p. 77): Check the habitat features that are present in the wetland. The number of checks is the number of points you put into the next column.</p> <p><input checked="" type="checkbox"/> Large, downed, woody debris within the wetland (> 4 in. diameter and 6 ft. long) <input type="checkbox"/> Standing snags (diameter at the bottom > 4 inches) in the wetland <input type="checkbox"/> Undercut banks are present for at least 6.6 ft. (2m) and/or overhanging vegetation extends at least 3.3 ft. (1m) over a stream (or ditch) in, or contiguous with the unit, for at least 33 ft. (10m) <input type="checkbox"/> Stable steep banks of fine material that might be used by beaver or muskrat for denning (> 30 degree slope) OR signs of recent beaver activity are present (cut shrubs or trees that have not yet turned grey/brown) <input type="checkbox"/> At least 1/4 acre of thin-stemmed persistent vegetation or woody branches are present in areas that are permanently or seasonally inundated (structures for egg-laying by amphibians) <input type="checkbox"/> Invasive plants cover less than 25% of the wetland area in each stratum of plants</p> <p><i>NOTE: The 20% stated in early printings of the manual on page 78 is an error.</i></p>	<p style="text-align: right;">1</p>								
H 1 TOTAL Score – potential for providing habitat		9								
Add the points in the column above										

H 2	Does the wetland have the <u>opportunity</u> to provide habitat for many species?	(only 1 score per box)
	<p>H 2.1 <u>Buffers</u> (see P. 80): Choose the description that best represents condition of buffer of wetland unit. The highest scoring criterion that applies to the wetland is to be used in the rating. See text for definition of "undisturbed".</p> <p><input type="checkbox"/> 100m (330 ft) of relatively undisturbed vegetated areas, rocky areas, or open water > 95% of circumference. No structures are within the undisturbed part of buffer (relatively undisturbed also means no grazing, no landscaping, no daily human use)..... points = 5</p> <p><input type="checkbox"/> 100m (330 ft) of relatively undisturbed vegetated areas, rocky areas, or open water > 50% circumference points = 4</p> <p><input type="checkbox"/> 50m (170 ft) of relatively undisturbed vegetated areas, rocky areas, or open water > 95% circumference points = 4</p> <p><input type="checkbox"/> 100m (330 ft) of relatively undisturbed vegetated areas, rocky areas, or open water > 25% circumference points = 3</p> <p><input type="checkbox"/> 50m (170 ft) of relatively undisturbed vegetated areas, rocky areas, or open water for > 50% circumference points = 3</p> <p>If buffer does not meet any of the criteria above:</p> <p><input type="checkbox"/> No paved areas (except paved trails) or buildings within 25m (80 ft) of wetland > 95% circumference. Light to moderate grazing or lawns are OK points = 2</p> <p><input type="checkbox"/> No paved areas of buildings within 50m of wetland for > 50% circumference. Light to moderate grazing or lawns are OK points = 2</p> <p><input type="checkbox"/> Heavy grazing in buffer points = 1</p> <p><input type="checkbox"/> Vegetated buffers are < 2m wide (6.6 ft) for more than 95% circumference (e.g. tilled fields, paving, basalt bedrock extend to edge of wetland) points = 0</p> <p><input checked="" type="checkbox"/> Buffer does not meet any of the criteria above points = 1</p> <p style="text-align: right;">Arial photo showing buffers</p>	<p>Figure <input type="checkbox"/></p> <p style="text-align: right;">1</p>
	<p>H 2.2 <u>Corridors and Connections</u> (see p. 81)</p> <p>H 2.2.1 Is the wetland part of a relatively undisturbed and unbroken vegetated corridor (either riparian or upland) that is at least 150 ft. wide, has at least a 30% cover of shrubs, forest or native undisturbed prairie, that connects to estuaries, other wetlands or undisturbed uplands that are at least 250 acres in size? (<i>Dams in riparian corridors, heavily used gravel roads, paved roads, are considered breaks in the corridor.</i>)</p> <p style="text-align: center;"><input type="checkbox"/> YES = 4 points (go to H 2.3) <input checked="" type="checkbox"/> NO = go to H 2.2.2</p> <p>H. 2.2.2 Is the wetland part of a relatively undisturbed and unbroken vegetated corridor (either riparian or upland) that is at least 50 ft. wide, has at least 30% cover of shrubs or forest, and connects to estuaries, other wetlands or undisturbed uplands that are at least 25 acres in size? OR a Lake-fringe wetland, if it does not have an undisturbed corridor as in the question above?</p> <p style="text-align: center;"><input type="checkbox"/> YES = 2 points (go to H 2.3) <input checked="" type="checkbox"/> NO = go to H 2.2.3</p> <p>H. 2.2.3 Is the wetland:</p> <ul style="list-style-type: none"> • Within 5 mi (8km) of a brackish or salt water estuary OR • Within 3 miles of a large field or pasture (> 40 acres) OR • Within 1 mile of a lake greater than 20 acres? <p style="text-align: right;"><input type="checkbox"/> YES = 1 point <input checked="" type="checkbox"/> NO = 0 points</p>	<p style="text-align: right;">0</p>

Comments: _____

	<p>H 2.3 <u>Near or adjacent to other priority habitats listed by WDFW</u> (see p. 82): (see new and complete descriptions of WDFW priority habitats, and the counties in which they can be found, in the PHS report http://wdfw.wa.gov/hab/phslist.htm)</p> <p>Which of the following priority habitats are within 330 ft. (100m) of the wetland unit? NOTE: the connections do not have to be relatively undisturbed.</p> <p><input type="checkbox"/> Aspen Stands: Pure or mixed stands of aspen greater than 0.4 ha (1 acre).</p> <p><input type="checkbox"/> Biodiversity Areas and Corridors: Areas of habitat that are relatively important to various species of native fish and wildlife (full descriptions in WDFW PHS report p. 152).</p> <p><input type="checkbox"/> Herbaceous Balds: Variable size patches of grass and forbs on shallow soils over bedrock.</p> <p><input type="checkbox"/> Old-growth/Mature forests: (Old-growth west of Cascade crest) Stands of at least 2 tree species, forming a multi-layered canopy with occasional small openings; with at least 20 trees/ha (8 trees/acre) > 81 cm (32 in) dbh or > 200 years of age. (Mature forests) Stands with average diameters exceeding 53 cm (21 in) dbh; crown cover may be less than 100%; decay, decadence, numbers of snags, and quantity of large downed material is generally less than that found in old-growth; 80 - 200 years old west of the Cascade crest.</p> <p><input type="checkbox"/> Oregon white Oak: Woodlands Stands of pure oak or oak/conifer associations where canopy coverage of the oak component is important (full descriptions in WDFW PHS report p. 158).</p> <p><input checked="" type="checkbox"/> Riparian: The area adjacent to aquatic systems with flowing water that contains elements of both aquatic and terrestrial ecosystems which mutually influence each other.</p> <p><input type="checkbox"/> Westside Prairies: Herbaceous, non-forested plant communities that can either take the form of a dry prairie or a wet prairie (full descriptions in WDFW PHS report p. 161).</p> <p><input checked="" type="checkbox"/> Instream: The combination of physical, biological, and chemical processes and conditions that interact to provide functional life history requirements for instream fish and wildlife resources.</p> <p><input type="checkbox"/> Nearshore: Relatively undisturbed nearshore habitats. These include Coastal Nearshore, Open Coast Nearshore, and Puget Sound Nearshore. (full descriptions of habitats and the definition of relatively undisturbed are in WDFW report: pp. 167-169 and glossary in Appendix A).</p> <p><input type="checkbox"/> Caves: A naturally occurring cavity, recess, void, or system of interconnected passages under the earth in soils, rock, ice, or other geological formations and is large enough to contain a human.</p> <p><input type="checkbox"/> Cliffs: Greater than 7.6 m (25 ft) high and occurring below 5000 ft.</p> <p><input type="checkbox"/> Talus: Homogenous areas of rock rubble ranging in average size 0.15 - 2.0 m (0.5 - 6.5 ft), composed of basalt, andesite, and/or sedimentary rock, including riprap slides and mine tailings. May be associated with cliffs.</p> <p><input type="checkbox"/> Snags and Logs: Trees are considered snags if they are dead or dying and exhibit sufficient decay characteristics to enable cavity excavation/use by wildlife. Priority snags have a diameter at breast height of > 51 cm (20 in) in western Washington and are > 2 m (6.5 ft) in height. Priority logs are > 30 cm (12 in) in diameter at the largest end, and > 6 m (20 ft) long.</p> <p style="text-align: right;">If wetland has 3 or more priority habitats = 4 points If wetland has 2 priority habitats = 3 points If wetland has 1 priority habitat = 1 point No habitats = 0 points</p> <p>Note: All vegetated wetlands are by definition a priority habitat but are not included in this list. Nearby wetlands are addressed in question H 2.4)</p>	3
	<p>H 2.4 <u>Wetland Landscape:</u> Choose the one description of the landscape around the wetland that best fits (see p. 84)</p> <ul style="list-style-type: none"> • There are at least 3 other wetlands within 1/2 mile, and the connections between them are relatively undisturbed (light grazing between wetlands OK, as is lake shore with some boating, but connections should NOT be bisected by paved roads, fill, fields, or other development.... points = 5 <input type="checkbox"/> • The wetland is Lake-fringe on a lake with little disturbance and there are 3 other lake-fringe wetlands within 1/2 mile points = 5 <input type="checkbox"/> • There are at least 3 other wetlands within 1/2 mile, BUT the connections between them are disturbed. points = 3 <input checked="" type="checkbox"/> • The wetland fringe on a lake with disturbance and there are 3 other lake-fringe wetlands within 1/2 mile points = 3 <input type="checkbox"/> • There is at least 1 wetland within 1/2 mile points = 2 <input type="checkbox"/> • There are no wetlands within 1/2 mile..... points = 0 <input type="checkbox"/> 	3
	<p>H 2 TOTAL Score – opportunity for providing habitat Add the scores from H2.1, H2.2, H2.3, H2.4</p>	7
	<p style="text-align: right;">TOTAL for H 1 from page 8</p>	9
◆	<p>Total Score for Habitat Functions Add the points for H 1 and H 2; then record the result on p. 1</p>	16

Comments: _____

CATEGORIZATION BASED ON SPECIAL CHARACTERISTICS

Please determine if the wetland meets the attributes described below and circle the appropriate answers and Category.

Wetland Type – Check off any criteria that apply to the wetland. Circle the Category when the appropriate criteria are met.	
SC1	<p>Estuarine wetlands? (see p.86)</p> <p>Does the wetland unit meet the following criteria for Estuarine wetlands?</p> <p><input type="checkbox"/> The dominant water regime is tidal, <input type="checkbox"/> Vegetated, and <input type="checkbox"/> With a salinity greater than 0.5 ppt.</p> <p style="text-align: center;"><input type="checkbox"/> YES = Go to SC 1.1 <input checked="" type="checkbox"/> NO</p>
	<p>SC 1.1 Is the wetland unit within a National Wildlife Refuge, National Park, National Estuary Reserve, Natural Area Preserve, State Park or Educational, Environmental, or Scientific Reserve designated under WAC 332-30-151? <input type="checkbox"/> YES = Category I <input type="checkbox"/> NO = go to SC 1.2</p>
	<p>SC 1.2 Is the wetland at least 1 acre in size and meets at least two of the following conditions?</p> <p style="text-align: center;"><input type="checkbox"/> YES = Category I <input type="checkbox"/> NO = Category II</p> <p><input type="checkbox"/> The wetland is relatively undisturbed (has no diking, ditching, filling, cultivation, grazing, and has less than 10% cover of non-native plant species. If the non-native <i>Spartina</i> spp. are only species that cover more than 10% of the wetland, then the wetland should be given a dual rating (I/II). The area of <i>Spartina</i> would be rated a Category II while the relatively undisturbed upper marsh with native species would be a Category I. Do not, however, exclude the area of <i>Spartina</i> in determining the size threshold of 1 acre.</p> <p><input type="checkbox"/> At least 3/4 of the landward edge of the wetland has a 100 ft. buffer of shrub, forest, or un-grazed or un-mowed grassland</p> <p><input type="checkbox"/> The wetland has at least 2 of the following features: tidal channels, depressions with open water, or contiguous freshwater wetlands.</p>
SC2	<p>Natural Heritage Wetlands (see p. 87)</p> <p>Natural Heritage wetlands have been identified by the Washington Natural Heritage Program/DNR as either high quality undisturbed wetlands or wetlands that support state Threatened, Endangered, or Sensitive plant species.</p> <p>SC 2.1 Is the wetland being rated in a Section/Township/Range that contains a natural heritage wetland? (This question is used to screen out most sites before you need to contact WNHP/DNR.)</p> <p style="text-align: center;"><input type="checkbox"/> S/T/R information from Appendix D <input type="checkbox"/> or accessed from WNHP/DNR web site <input type="checkbox"/> YES Contact WNHP/DNR (see p. 79) and go to SC 2.2 <input checked="" type="checkbox"/> NO</p> <p>SC 2.2 Has DNR identified the wetland as a high quality undisturbed wetland or as a site with state threatened or endangered plant species?</p> <p style="text-align: center;"><input type="checkbox"/> YES = Category 1 <input checked="" type="checkbox"/> NO not a Heritage Wetland</p>
SC3	<p>Bogs (see p. 87)</p> <p>Does the wetland (or any part of the unit) meet both the criteria for soils and vegetation in bogs? Use the key below to identify if the wetland is a bog. If you answer yes you will still need to rate the wetland based on its function.</p> <ol style="list-style-type: none"> Does the unit have organic soil horizons (i.e. layers of organic soil), either peats or mucks, that compose 16 inches or more of the first 32 inches of soil profile? (See Appendix B for a field key to identify organic soils)? <input type="checkbox"/> YES = go to question 3 <input checked="" type="checkbox"/> NO = go to question 2 Does the wetland have organic soils, either peats or mucks that are less than 16 inches deep over bedrock, or an impermeable hardpan such as clay or volcanic ash, or that are floating on a lake or pond? <input type="checkbox"/> YES = go to question 3 <input checked="" type="checkbox"/> NO = is not a bog for purpose of rating Does the unit have more than 70% cover of mosses at ground level, AND other plants, if present, consist of the “bog” species listed in Table 3 as a significant component of the vegetation (more than 30% of the total shrub and herbaceous cover consists of species in Table 3)? <p style="text-align: center;"><input type="checkbox"/> YES = Is a bog for purpose of rating <input checked="" type="checkbox"/> NO = go to question 4</p> <p>NOTE: If you are uncertain about the extent of mosses in the understory you may substitute that criterion by measuring the pH of the water that seeps into a hole dug at least 16” deep. If the pH is less than 5.0 and the “bog” plant species in Table 3 are present, the wetland is a bog.</p> <ol style="list-style-type: none"> Is the unit forested (> 30% cover) with sitka spruce, subalpine fir, western red cedar, western hemlock, lodgepole pine, quaking aspen, Englemann’s spruce, or western white pine. WITH any of the species (or combination of species) on the bog species plant list in Table 3 as a significant component of the ground cover (> 30% coverage of the total shrub/herbaceous cover)? <p style="text-align: center;"><input type="checkbox"/> YES = Category I <input checked="" type="checkbox"/> NO = Is not a bog for purpose of rating</p>
	<p>Cat. I <input type="checkbox"/></p> <p>Cat. II <input type="checkbox"/></p> <p>Dual Rating I/II <input type="checkbox"/></p> <p>Cat I <input type="checkbox"/></p> <p>Cat. I <input type="checkbox"/></p>

SC4	<p>Forested Wetlands (see p. 90)</p> <p>Does the wetland have at least 1 acre of forest that meet one of these criteria for the Department of Fish and Wildlife's forests as priority habitats? <i>If you answer yes you will still need to rate the wetland based on its function.</i></p> <p><input type="checkbox"/> Old-growth forests: (west of Cascade Crest) Stands of at least two three species forming a multi-layered canopy with occasional small openings; with at least 8 trees/acre (20 trees/hectare) that are at least 200 years of age OR have a diameter at breast height (dbh) of 32 inches (81 cm or more). NOTE: The criterion for dbh is based on measurements for upland forests. Two-hundred year old trees in wetlands will often have a smaller dbh because their growth rates are often slower. The DFW criterion is and "OR" so old-growth forests do not necessarily have to have trees of this diameter.</p> <p><input type="checkbox"/> Mature forests: (west of the Cascade Crest) Stands where the largest trees are 80 – 200 years old OR have an average diameters (dbh) exceeding 21 inches (53 cm); crown cover may be less than 100%; decay, decadence, numbers of snags, and quantity of large downed material is generally less than that found in old-growth.</p> <p><input type="checkbox"/> YES = Category I <input checked="" type="checkbox"/> NO = not a forested wetland with special characteristics</p>	<p>Cat. I <input type="checkbox"/></p>
SC5	<p>Wetlands in Coastal Lagoons (see p. 91)</p> <p>Does the wetland meet all of the following criteria of a wetland in a coastal lagoon?</p> <p><input type="checkbox"/> The wetland lies in a depression adjacent to marine waters that is wholly or partially separated from marine waters by sandbanks, gravel banks, shingle, or, less frequently, rocks.</p> <p><input type="checkbox"/> The lagoon in which the wetland is located contains surface water that is saline or brackish (> 0.5 ppt) during most of the year in at least a portion of the lagoon (<i>needs to be measured near the bottom.</i>)</p> <p><input type="checkbox"/> YES = Go to SC 5.1 <input checked="" type="checkbox"/> NO not a wetland in a coastal lagoon</p> <p>SC 5.1 Does the wetland meet all of the following three conditions?</p> <p><input type="checkbox"/> The wetland is relatively undisturbed (has no diking, ditching, filling, cultivation, grazing) and has less than 20% cover of invasive plant species (see list of invasive species on p. 74).</p> <p><input type="checkbox"/> At least 3/4 of the landward edge of the wetland has a 100 ft. buffer of shrub, forest, or un-grazed or un-mowed grassland.</p> <p><input type="checkbox"/> The wetland is larger than 1/10 acre (4350 square ft.)</p> <p><input type="checkbox"/> YES = Category I <input type="checkbox"/> NO = Category II</p>	<p>Cat. I <input type="checkbox"/></p> <p>Cat. II <input type="checkbox"/></p>
SC6	<p>Interdunal Wetlands (see p. 93)</p> <p>Is the wetland west of the 1889 line (also called the Western Boundary of Upland Ownership or WBUO)?</p> <p><input type="checkbox"/> YES = Go to SC 6.1 <input checked="" type="checkbox"/> NO not an interdunal wetland for rating</p> <p><i>If you answer yes you will still need to rate the wetland based on its functions.</i></p> <p>In practical terms that means the following geographic areas:</p> <ul style="list-style-type: none"> • Long Beach Peninsula -- lands west of SR 103 • Grayland-Westport -- lands west of SR 105 • Ocean Shores-Copalis – lands west of SR 115 and SR 109 <p>SC 6.1 Is the wetland one acre or larger, or is it in a mosaic of wetlands that is one acre or larger?</p> <p><input type="checkbox"/> YES = Category II <input type="checkbox"/> NO = go to SC 6.2</p> <p>SC 6.2 Is the wetland between 0.1 and 1 acre, or is it in a mosaic of wetlands that is between 0.1 and 1 acre?</p> <p><input type="checkbox"/> YES = Category III</p>	<p>Cat. II <input type="checkbox"/></p> <p>Cat. III <input type="checkbox"/></p>
◆	<p>Category of wetland based on Special Characteristics</p> <p>Choose the "highest" rating if wetland falls into several categories, and record on p. 1. If you answered NO for all types enter "Not Applicable" on p. 1</p>	<p>NA</p>

Comments:

Wetland name or number Lake Bellevue

WETLAND RATING FORM – WESTERN WASHINGTON

Version 2 - Updated July 2006 to increase accuracy and reproducibility among users
 Updated Oct 2008 with the new WDFW definitions for priority habitats

Name of wetland (if known): Lake Bellevue Date of site visit: 4/9/13

Rated by Joseph R. Pursley Trained by Ecology? Yes No Date of training May 07'

SEC: 29 TOWNSHIP: 24N RANGE: 5E Is S/T/R in Appendix D? Yes No

Map of wetland unit: Figure Estimated size 9.0 acres

SUMMARY OF RATING

Category based on FUNCTIONS provided by wetland

I II III IV

Category I = Score >=70 Category II = Score 51-69 Category III = Score 30-50 Category IV = Score < 30
--

Score for Water Quality Functions	2
Score for Hydrologic Functions	16
Score for Habitat Functions	12
TOTAL score for Functions	30

Category based on SPECIAL CHARACTERISTICS of wetland

I II Does not Apply

Final Category (choose the “highest” category from above)

III

Summary of basic information about the wetland unit

Wetland Unit has Special Characteristics	Wetland HGM Class used for Rating	
Estuarine	Depressional	<input checked="" type="checkbox"/>
Natural Heritage Wetland	Riverine	<input type="checkbox"/>
Bog	Lake-fringe	<input type="checkbox"/>
Mature Forest	Slope	<input type="checkbox"/>
Old Growth Forest	Flats	<input type="checkbox"/>
Coastal Lagoon	Freshwater Tidal	<input type="checkbox"/>
Interdunal		<input type="checkbox"/>
None of the above	Check if unit has multiple HGM classes present	<input type="checkbox"/>

Does the wetland unit being rated meet any of the criteria below?

If you answer YES to any of the questions below you will need to protect the wetland according to the regulations regarding the special characteristics found in the wetland.

Check List for Wetlands That May Need Additional Protection (in addition to the protection recommended for its category)	YES	NO
<p>SP1. <i>Has the wetland unit been documented as a habitat for any Federally listed Threatened or Endangered animal or plant species (T/E species)?</i> For the purposes of this rating system, "documented" means the wetland is on the appropriate state or federal database.</p>		X
<p>SP2. <i>Has the wetland unit been documented as habitat for any State listed Threatened or Endangered animal species?</i> For the purposes of this rating system, "documented" means the wetland is on the appropriate state database. Note: Wetlands with State listed plant species are categorized as Category I Natural Heritage Wetlands (see p. 19 of data form).</p>		X
<p>SP3. <i>Does the wetland unit contain individuals of Priority species listed by the WDFW for the state?</i></p>		X
<p>SP4. <i>Does the wetland unit have a local significance in addition to its functions?</i> For example, the wetland has been identified in the Shoreline Master Program, the Critical Areas Ordinance, or in a local management plan as having special significance.</p>		X

To complete the next part of the data sheet you will need to determine the Hydrogeomorphic Class of the wetland being rated.

The hydrogeomorphic classification groups wetlands into those that function in similar ways. This simplifies the questions needed to answer how well the wetland functions. The Hydrogeomorphic Class of a wetland can be determined using the key below. See p. 24 for more detailed instructions on classifying wetlands.

Classification of Wetland Units in Western Washington

If the hydrologic criteria listed in each question do not apply to the entire unit being rated, you probably have a unit with multiple HGM classes. In this case, identify which hydrologic criteria in questions 1-7 apply, and go to Question 8.

1. Are the water levels in the entire unit usually controlled by tides (i.e. except during floods)?

NO – go to 2 **YES** – the wetland class is **Tidal Fringe**

If yes, is the salinity of the water during periods of annual low flow below 0.5 ppt (parts per thousand)? **YES** – **Freshwater Tidal Fringe** **NO** – **Saltwater Tidal Fringe (Estuarine)**

*If your wetland can be classified as a Freshwater Tidal Fringe use the forms for **Riverine** wetlands. If it is Saltwater Tidal Fringe it is rated as an **Estuarine** wetland. Wetlands that were called estuarine in the first and second editions of the rating system are called Salt Water Tidal Fringe in the Hydrogeomorphic Classification. Estuarine wetlands were categorized separately in the earlier editions, and this separation is being kept in this revision. To maintain consistency between editions, the term “Estuarine” wetland is kept. Please note, however, that the characteristics that define Category I and II estuarine wetlands have changed (see p.).*

2. The entire wetland unit is flat and precipitation is the only source (>90%) of water to it.

Groundwater and surface water runoff are NOT sources of water to the unit.

NO – go to 3 **YES** – The wetland class is **Flats**

If your wetland can be classified as a “Flats” wetland, use the form for **Depressional** wetlands.

3. Does the entire wetland unit **meet both** of the following criteria?

The vegetated part of the wetland is on the shores of a body of permanent open water (without any vegetation on the surface) at least 20 acres (8 ha) in size;

At least 30% of the open water area is deeper than 6.6 ft (2 m)?

NO – go to 4 **YES** – The wetland class is **Lake-fringe (Lacustrine Fringe)**

4. Does the entire wetland unit **meet all** of the following criteria?

The wetland is on a slope (*slope can be very gradual*),

The water flows through the wetland in one direction (unidirectional) and usually comes from seeps. It may flow subsurface, as sheetflow, or in a swale without distinct banks.

The water leaves the wetland **without being impounded**?

NOTE: *Surface water does not pond in these type of wetlands except occasionally in very small and shallow depressions or behind hummocks (depressions are usually <3ft diameter and less than 1 foot deep).*

NO – go to 5 **YES** – The wetland class is **Slope**

5. Does the entire wetland unit **meet all** of the following criteria?

_____ The unit is in a valley, or stream channel, where it gets inundated by overbank flooding from that stream or river

_____ The overbank flooding occurs at least once every two years.

NOTE: The riverine unit can contain depressions that are filled with water when the river is not flooding.

NO - go to 6 **YES** - The wetland class is **Riverine**

6. Is the entire wetland unit in a topographic depression in which water ponds, or is saturated to the surface, at some time during the year. *This means that any outlet, if present, is higher than the interior of the wetland.*

NO - go to 7 **YES** - The wetland class is **Depressional**

7. Is the entire wetland unit located in a very flat area with no obvious depression and no overbank flooding. The unit does not pond surface water more than a few inches. The unit seems to be maintained by high groundwater in the area. The wetland may be ditched, but has no obvious natural outlet.

NO - go to 8 **YES** - The wetland class is **Depressional**

8. Your wetland unit seems to be difficult to classify and probably contains several different HGM classes. For example, seeps at the base of a slope may grade into a riverine floodplain, or a small stream within a depressional wetland has a zone of flooding along its sides. **GO BACK AND IDENTIFY WHICH OF THE HYDROLOGIC REGIMES DESCRIBED IN QUESTIONS 1-7 APPLY TO DIFFERENT AREAS IN THE UNIT** (make a rough sketch to help you decide). Use the following table to identify the appropriate class to use for the rating system if you have several HGM classes present within your wetland. **NOTE:** Use this table only if the class that is recommended in the second column represents 10% or more of the total area of the wetland unit being rated. If the area of the class listed in column 2 is less than 10% of the unit; classify the wetland using the class that represents more than 90% of the total area.

<i>HGM Classes within the wetland unit being rated</i>	<i>HGM Class to Use in Rating</i>
Slope + Riverine	Riverine
Slope + Depressional	Depressional
Slope + Lake-fringe	Lake-fringe
Depressional + Riverine along stream within boundary	Depressional
Depressional + Lake-fringe	Depressional
Salt Water Tidal Fringe and any other class of freshwater wetland	Treat as ESTUARINE under wetlands with special characteristics

If you are unable still to determine which of the above criteria apply to your wetland, or if you have more than 2 HGM classes within a wetland boundary, classify the wetland as **Depressional** for the rating.

D Depressional and Flats Wetlands		Points (only 1 score per box)
WATER QUALITY FUNCTIONS - Indicators that the wetland unit functions to improve water quality		
D	D 1. Does the wetland unit have the <u>potential</u> to improve water quality?	(see p.38)
D	<p>D 1.1 Characteristics of surface water flows out of the wetland: Unit is a depression with no surface water leaving it (no outlet) points = 3 Unit has an intermittently flowing, OR highly constricted permanently flowing outlet points = 2 Unit has an unconstricted, or slightly constricted, surface outlet (<i>permanently flowing</i>) points = 1 Unit is a "flat" depression (Q. 7 on key), or in the Flats class, with permanent surface outflow and no obvious natural outlet and/or outlet is a man-made ditch points = 1 (If ditch is not permanently flowing treat unit as "intermittently flowing")</p> <p style="text-align: right;">Provide photo or drawing</p>	Figure ____ 1
D	<p>S 1.2 The soil 2 inches below the surface (or duff layer) is clay or organic (<i>use NRCS definitions</i>)</p> <p>YES points = 4 NO points = 0</p>	0
D	<p>D 1.3 Characteristics of persistent vegetation (emergent, shrub, and/or forest Cowardin class)</p> <p>Wetland has persistent, ungrazed, vegetation > = 95% of area points = 5 Wetland has persistent, ungrazed, vegetation > = 1/2 of area points = 3 Wetland has persistent, ungrazed vegetation > = 1/10 of area points = 1 Wetland has persistent, ungrazed vegetation < 1/10 of area points = 0</p> <p style="text-align: right;">Map of Cowardin vegetation classes</p>	Figure ____ 0
D	<p>D1.4 Characteristics of seasonal ponding or inundation. <i>This is the area of the wetland unit that is ponded for at least 2 months, but dries out sometime during the year. Do not count the area that is permanently ponded. Estimate area as the average condition 5 out of 10 yrs.</i></p> <p>Area seasonally ponded is > 1/2 total area of wetland points = 4 Area seasonally ponded is > 1/4 total area of wetland points = 2 Area seasonally ponded is < 1/4 total area of wetland points = 0</p> <p style="text-align: right;">Map of Hydroperiods</p>	Figure ____ 0
D	Total for D 1	<i>Add the points in the boxes above</i> 1
D	<p>D 2. Does the wetland unit have the <u>opportunity</u> to improve water quality? Answer YES if you know or believe there are pollutants in groundwater or surface water coming into the wetland that would otherwise reduce water quality in streams, lakes or groundwater downgradient from the wetland. <i>Note which of the following conditions provide the sources of pollutants. A unit may have pollutants coming from several sources, but any single source would qualify as opportunity.</i></p> <p> <input type="checkbox"/> Grazing in the wetland or within 150 ft <input checked="" type="checkbox"/> Untreated stormwater discharges to wetland <input type="checkbox"/> Tilled fields or orchards within 150 ft of wetland <input checked="" type="checkbox"/> A stream or culvert discharges into wetland that drains developed areas, residential areas, farmed fields, roads, or clear-cut logging <input type="checkbox"/> Residential, urban areas, golf courses are within 150 ft of wetland <input type="checkbox"/> Wetland is fed by groundwater high in phosphorus or nitrogen <input type="checkbox"/> Other _____ </p> <p>YES multiplier is 2 NO multiplier is 1</p>	(see p. 44) multiplier 2
D	TOTAL - Water Quality Functions	Multiply the score from D1 by D2 <i>Add score to table on p. 1</i> 2

D Depressional and Flats Wetlands		Points
HYDROLOGIC FUNCTIONS - Indicators that the wetland unit functions to reduce flooding and stream degradation		(only 1 score per box)
D	D 3. Does the wetland unit have the <u>potential</u> to reduce flooding and erosion?	<i>(see p.46)</i>
D	<p>D 3.1 Characteristics of surface water flows out of the wetland unit</p> <p>Unit is a depression with no surface water leaving it (no outlet) points = 4</p> <p>Unit has an intermittently flowing, OR highly constricted permanently flowing outlet points = 2</p> <p>Unit is a "flat" depression (Q. 7 on key), or in the Flats class, with permanent surface outflow and no obvious natural outlet and/or outlet is a man-made ditch points = 1</p> <p><i>(If ditch is not permanently flowing treat unit as "intermittently flowing")</i></p> <p>Unit has an unconstricted, or slightly constricted, surface outlet (<i>permanently flowing</i>) points = 0</p>	0
D	<p>D 3.2 Depth of storage during wet periods</p> <p><i>Estimate the height of ponding above the bottom of the outlet. For units with no outlet measure from the surface of permanent water or deepest part (if dry).</i></p> <p>Marks of ponding are 3 ft or more above the surface or bottom of outlet points = 7</p> <p>The wetland is a "headwater" wetland points = 5</p> <p>Marks of ponding between 2 ft to < 3 ft from surface or bottom of outlet points = 5</p> <p>Marks are at least 0.5 ft to < 2 ft from surface or bottom of outlet points = 3</p> <p>Unit is flat (yes to Q. 2 or Q. 7 on key) but has small depressions on the surface that trap water points = 1</p> <p>Marks of ponding less than 0.5 ft points = 0</p>	3
D	<p>D 3.3 Contribution of wetland unit to storage in the watershed</p> <p><i>Estimate the ratio of the area of upstream basin contributing surface water to the wetland to the area of the wetland unit itself.</i></p> <p>The area of the basin is less than 10 times the area of unit points = 5</p> <p>The area of the basin is 10 to 100 times the area of the unit points = 3</p> <p>The area of the basin is more than 100 times the area of the unit points = 0</p> <p>Entire unit is in the FLATS class points = 5</p>	5
D	Total for D 3 <i>Add the points in the boxes above</i>	8
D	<p>D 4. Does the wetland unit have the <u>opportunity</u> to reduce flooding and erosion?</p> <p>Answer YES if the unit is in a location in the watershed where the flood storage, or reduction in water velocity, it provides helps protect downstream property and aquatic resources from flooding or excessive and/or erosive flows. Answer NO if the water coming into the wetland is controlled by a structure such as flood gate, tide gate, flap valve, reservoir etc. OR you estimate that more than 90% of the water in the wetland is from groundwater in areas where damaging groundwater flooding does not occur.</p> <p><i>Note which of the following indicators of opportunity apply.</i></p> <p><input checked="" type="checkbox"/> Wetland is in a headwater of a river or stream that has flooding problems</p> <p><input checked="" type="checkbox"/> Wetland drains to a river or stream that has flooding problems</p> <p><input type="checkbox"/> Wetland has no outlet and impounds surface runoff water that might otherwise flow into a river or stream that has flooding problems</p> <p><input type="checkbox"/> Other _____</p> <p>YES multiplier is 2 NO multiplier is 1</p>	<i>(see p. 49)</i> multiplier 2
D	TOTAL - Hydrologic Functions Multiply the score from D 3 by D 4 <i>Add score to table on p. 1</i>	16

R Riverine and Freshwater Tidal Fringe Wetlands		Points										
WATER QUALITY FUNCTIONS - Indicators that wetland functions to improve water quality		(only 1 score per box)										
R	R 1. Does the wetland unit have the <u>potential</u> to improve water quality?	<i>(see p.52)</i>										
R	<p>R 1.1 Area of surface depressions within the riverine wetland that can trap sediments during a flooding event:</p> <table style="width: 100%; border: none;"> <tr> <td style="padding-left: 20px;">Depressions cover >3/4 area of wetland</td> <td style="text-align: right;">points = 8</td> </tr> <tr> <td style="padding-left: 20px;">Depressions cover > 1/2 area of wetland</td> <td style="text-align: right;">points = 4</td> </tr> <tr style="background-color: #e0e0e0;"> <td colspan="2" style="padding-left: 20px;">If depressions > 1/2 of area of unit draw polygons on aerial photo or map</td> </tr> <tr> <td style="padding-left: 20px;">Depressions present but cover < 1/2 area of wetland</td> <td style="text-align: right;">points = 2</td> </tr> <tr> <td style="padding-left: 20px;">No depressions present</td> <td style="text-align: right;">points = 0</td> </tr> </table>	Depressions cover >3/4 area of wetland	points = 8	Depressions cover > 1/2 area of wetland	points = 4	If depressions > 1/2 of area of unit draw polygons on aerial photo or map		Depressions present but cover < 1/2 area of wetland	points = 2	No depressions present	points = 0	Figure ____
Depressions cover >3/4 area of wetland	points = 8											
Depressions cover > 1/2 area of wetland	points = 4											
If depressions > 1/2 of area of unit draw polygons on aerial photo or map												
Depressions present but cover < 1/2 area of wetland	points = 2											
No depressions present	points = 0											
R	<p>R 1.2 Characteristics of the vegetation in the unit (areas with >90% cover at person height):</p> <table style="width: 100%; border: none;"> <tr> <td style="padding-left: 20px;">Trees or shrubs > 2/3 the area of the unit</td> <td style="text-align: right;">points = 8</td> </tr> <tr> <td style="padding-left: 20px;">Trees or shrubs > 1/3 area of the unit</td> <td style="text-align: right;">points = 6</td> </tr> <tr> <td style="padding-left: 20px;">Ungrazed, herbaceous plants > 2/3 area of unit</td> <td style="text-align: right;">points = 6</td> </tr> <tr> <td style="padding-left: 20px;">Ungrazed herbaceous plants > 1/3 area of unit</td> <td style="text-align: right;">points = 3</td> </tr> <tr> <td style="padding-left: 20px;">Trees, shrubs, and ungrazed herbaceous < 1/3 area of unit</td> <td style="text-align: right;">points = 0</td> </tr> </table> <p>Aerial photo or map showing polygons of different vegetation types</p>	Trees or shrubs > 2/3 the area of the unit	points = 8	Trees or shrubs > 1/3 area of the unit	points = 6	Ungrazed, herbaceous plants > 2/3 area of unit	points = 6	Ungrazed herbaceous plants > 1/3 area of unit	points = 3	Trees, shrubs, and ungrazed herbaceous < 1/3 area of unit	points = 0	Figure ____
Trees or shrubs > 2/3 the area of the unit	points = 8											
Trees or shrubs > 1/3 area of the unit	points = 6											
Ungrazed, herbaceous plants > 2/3 area of unit	points = 6											
Ungrazed herbaceous plants > 1/3 area of unit	points = 3											
Trees, shrubs, and ungrazed herbaceous < 1/3 area of unit	points = 0											
R	<i>Add the points in the boxes above</i>											
R	<p>R 2. Does the wetland unit have the <u>opportunity</u> to improve water quality?</p> <p>Answer YES if you know or believe there are pollutants in groundwater or surface water coming into the wetland that would otherwise reduce water quality in streams, lakes or groundwater downgradient from the wetland? <i>Note which of the following conditions provide the sources of pollutants. A unit may have pollutants coming from several sources, but any single source would qualify as opportunity.</i></p> <ul style="list-style-type: none"> — Grazing in the wetland or within 150ft — Untreated stormwater discharges to wetland — Tilled fields or orchards within 150 feet of wetland — A stream or culvert discharges into wetland that drains developed areas, residential areas, farmed fields, roads, or clear-cut logging — Residential, urban areas, golf courses are within 150 ft of wetland — The river or stream linked to the wetland has a contributing basin where human activities have raised levels of sediment, toxic compounds or nutrients in the river water above standards for water quality — Other _____ <p>YES multiplier is 2 NO multiplier is 1</p>	<i>(see p.53)</i>										
R	<p><u>TOTAL</u> - Water Quality Functions Multiply the score from R 1 by R 2</p> <p style="text-align: right;"><i>Add score to table on p. 1</i></p>	multiplier ____										

Comments

R Riverine and Freshwater Tidal Fringe Wetlands HYDROLOGIC FUNCTIONS - Indicators that wetland functions to reduce flooding and stream erosion		Points (only 1 score per box)
	R 3. Does the wetland unit have the <u>potential</u> to reduce flooding and erosion?	(see p.54)
R	R 3.1 Characteristics of the overbank storage the unit provides: <i>Estimate the average width of the wetland unit perpendicular to the direction of the flow and the width of the stream or river channel (distance between banks). Calculate the ratio: (average width of unit)/(average width of stream between banks).</i> If the ratio is more than 20 points = 9 If the ratio is between 10 – 20 points = 6 If the ratio is 5 - <10 points = 4 If the ratio is 1 - <5 points = 2 If the ratio is < 1 points = 1 Aerial photo or map showing average widths	Figure ____
R	R 3.2 Characteristics of vegetation that slow down water velocities during floods: <i>Treat large woody debris as "forest or shrub". Choose the points appropriate for the best description.</i> (polygons need to have >90% cover at person height NOT Cowardin classes): Forest or shrub for >1/3 area OR herbaceous plants > 2/3 area points = 7 Forest or shrub for > 1/10 area OR herbaceous plants > 1/3 area points = 4 Vegetation does not meet above criteria points = 0 Aerial photo or map showing polygons of different vegetation types	Figure ____
R	<i>Add the points in the boxes above</i>	
R	R 4. Does the wetland unit have the <u>opportunity</u> to reduce flooding and erosion? Answer YES if the unit is in a location in the watershed where the flood storage, or reduction in water velocity, it provides helps protect downstream property and aquatic resources from flooding or excessive and/or erosive flows. <i>Note which of the following conditions apply.</i> — There are human structures and activities downstream (roads, buildings, bridges, farms) that can be damaged by flooding. — There are natural resources downstream (e.g. salmon redds) that can be damaged by flooding — Other _____ (Answer NO if the major source of water to the wetland is controlled by a reservoir or the wetland is tidal fringe along the sides of a dike) YES multiplier is 2 NO multiplier is 1	(see p.57) multiplier _____
R	TOTAL - Hydrologic Functions Multiply the score from R 3 by R 4 <i>Add score to table on p. 1</i>	

Comments

L Lake-fringe Wetlands		Points
WATER QUALITY FUNCTIONS - Indicators that the wetland unit functions to improve water quality		(only 1 score per box)
L	L 1. Does the wetland unit have the <u>potential</u> to improve water quality?	(see p.59)
L	<p>L 1.1 Average width of vegetation along the lakeshore (<i>use polygons of Cowardin classes</i>):</p> <p>Vegetation is more than 33ft (10m) wide points = 6</p> <p>Vegetation is more than 16 (5m) wide and <33ft points = 3</p> <p>Vegetation is more than 6ft (2m) wide and <16 ft points = 1</p> <p>Vegetation is less than 6 ft wide points = 0</p> <p style="text-align: right;">Map of Cowardin classes with widths marked</p>	Figure ____
L	<p>L 1.2 Characteristics of the vegetation in the wetland: <i>choose the appropriate description that results in the highest points, and do not include any open water in your estimate of coverage. The herbaceous plants can be either the dominant form or as an understory in a shrub or forest community. These are not Cowardin classes. Area of Cover is total cover in the unit, but it can be in patches. NOTE: Herbaceous does not include aquatic bed.</i></p> <p>Cover of herbaceous plants is >90% of the vegetated area points = 6</p> <p>Cover of herbaceous plants is >2/3 of the vegetated area points = 4</p> <p>Cover of herbaceous plants is >1/3 of the vegetated area points = 3</p> <p>Other vegetation that is not aquatic bed or herbaceous covers > 2/3 unit points = 3</p> <p>Other vegetation that is not aquatic bed in > 1/3 vegetated area points = 1</p> <p>Aquatic bed vegetation and open water cover > 2/3 of the unit points = 0</p> <p style="text-align: right;">Map with polygons of different vegetation types</p>	Figure ____
L	<i>Add the points in the boxes above</i>	
L	<p>L 2. Does the wetland have the <u>opportunity</u> to improve water quality?</p> <p>Answer YES if you know or believe there are pollutants in the lake water, or polluted surface water flowing through the unit to the lake. <i>Note which of the following conditions provide the sources of pollutants. A unit may have pollutants coming from several sources, but any single source would qualify as opportunity.</i></p> <ul style="list-style-type: none"> — Wetland is along the shores of a lake or reservoir that does not meet water quality standards — Grazing in the wetland or within 150ft — Polluted water discharges to wetland along upland edge — Tilled fields or orchards within 150 feet of wetland — Residential or urban areas are within 150 ft of wetland — Parks with grassy areas that are maintained, ballfields, golf courses (all within 150 ft. of lake shore) — Power boats with gasoline or diesel engines use the lake — Other _____ <p>YES multiplier is 2 NO multiplier is 1</p>	(see p.61)
L	<p><u>TOTAL</u> - Water Quality Functions Multiply the score from L1 by L2</p> <p style="text-align: right;"><i>Add score to table on p. 1</i></p>	multiplier _____

Comments

S Slope Wetlands		Points
WATER QUALITY FUNCTIONS - Indicators that the wetland unit functions to improve water quality		(only 1 score per box)
S	S 1. Does the wetland unit have the <u>potential</u> to improve water quality?	<i>(see p.64)</i>
S	<p>S 1.1 Characteristics of average slope of unit:</p> <p>Slope is 1% or less (<i>a 1% slope has a 1 foot vertical drop in elevation for every 100 ft horizontal distance</i>) points = 3</p> <p>Slope is 1% - 2% points = 2</p> <p>Slope is 2% - 5% points = 1</p> <p>Slope is greater than 5% points = 0</p>	
S	<p>S 1.2 The soil 2 inches below the surface (or duff layer) is clay or organic (<i>use NRCS definitions</i>)</p> <p>YES = 3 points NO = 0 points</p>	
S	<p>S 1.3 Characteristics of the vegetation in the wetland that trap sediments and pollutants: <i>Choose the points appropriate for the description that best fits the vegetation in the wetland. Dense vegetation means you have trouble seeing the soil surface (>75% cover), and uncut means not grazed or mowed and plants are higher than 6 inches.</i></p> <p>Dense, uncut, herbaceous vegetation > 90% of the wetland area points = 6</p> <p>Dense, uncut, herbaceous vegetation > 1/2 of area points = 3</p> <p>Dense, woody, vegetation > 1/2 of area points = 2</p> <p>Dense, uncut, herbaceous vegetation > 1/4 of area points = 1</p> <p>Does not meet any of the criteria above for vegetation points = 0</p> <p style="text-align: center;">Aerial photo or map with vegetation polygons</p>	Figure _____
S	Total for S 1	<i>Add the points in the boxes above</i>
S	<p>S 2. Does the wetland unit have the <u>opportunity</u> to improve water quality?</p> <p>Answer YES if you know or believe there are pollutants in groundwater or surface water coming into the wetland that would otherwise reduce water quality in streams, lakes or groundwater downgradient from the wetland. <i>Note which of the following conditions provide the sources of pollutants. A unit may have pollutants coming from several sources, but any single source would qualify as opportunity.</i></p> <p>— Grazing in the wetland or within 150ft</p> <p>— Untreated stormwater discharges to wetland</p> <p>— Tilled fields, logging, or orchards within 150 feet of wetland</p> <p>— Residential, urban areas, or golf courses are within 150 ft upslope of wetland</p> <p>— Other _____</p> <p>YES multiplier is 2 NO multiplier is 1</p>	<i>(see p.67)</i>
S	TOTAL - Water Quality Functions	Multiply the score from S1 by S2 <i>Add score to table on p. 1</i>

Comments

S Slope Wetlands		Points
HYDROLOGIC FUNCTIONS - Indicators that the wetland unit functions to reduce flooding and stream erosion		(only 1 score per box)
S	S 3. Does the wetland unit have the <u>potential</u> to reduce flooding and stream erosion?	<i>(see p.68)</i>
S	<p>S 3.1 Characteristics of vegetation that reduce the velocity of surface flows during storms. <i>Choose the points appropriate for the description that best fit conditions in the wetland. (stems of plants should be thick enough (usually > 1/8in), or dense enough, to remain erect during surface flows)</i></p> <p>Dense, uncut, rigid vegetation covers > 90% of the area of the wetland. points = 6</p> <p>Dense, uncut, rigid vegetation > 1/2 area of wetland points = 3</p> <p>Dense, uncut, rigid vegetation > 1/4 area points = 1</p> <p>More than 1/4 of area is grazed, mowed, tilled or vegetation is not rigid points = 0</p>	
S	<p>S 3.2 Characteristics of slope wetland that holds back small amounts of flood flows: The slope wetland has small surface depressions that can retain water over at least 10% of its area.</p> <p style="text-align: right;">YES points = 2 NO points = 0</p>	
S	<i>Add the points in the boxes above</i>	
S	<p>S 4. Does the wetland have the <u>opportunity</u> to reduce flooding and erosion? Is the wetland in a landscape position where the reduction in water velocity it provides helps protect downstream property and aquatic resources from flooding or excessive and/or erosive flows? <i>Note which of the following conditions apply.</i></p> <p>— Wetland has surface runoff that drains to a river or stream that has flooding problems</p> <p>— Other _____</p> <p><i>(Answer NO if the major source of water is controlled by a reservoir (e.g. wetland is a seep that is on the downstream side of a dam))</i></p> <p>YES multiplier is 2 NO multiplier is 1</p>	<i>(see p. 70)</i> multiplier _____
S	TOTAL - Hydrologic Functions Multiply the score from S 3 by S 4 <i>Add score to table on p. 1</i>	

Comments

These questions apply to wetlands of all HGM classes.		Points (only 1 score per box)											
HABITAT FUNCTIONS - Indicators that unit functions to provide important habitat													
H 1. Does the wetland unit have the <u>potential</u> to provide habitat for many species?													
<p>H 1.1 Vegetation structure (see p. 72) Check the types of vegetation classes present (as defined by Cowardin)- Size threshold for each class is ¼ acre or more than 10% of the area if unit is smaller than 2.5 acres.</p> <p><input checked="" type="checkbox"/> Aquatic bed <input type="checkbox"/> Emergent plants <input type="checkbox"/> Scrub/shrub (areas where shrubs have >30% cover) <input type="checkbox"/> Forested (areas where trees have >30% cover)</p> <p>If the unit has a forested class check if: <input type="checkbox"/> The forested class has 3 out of 5 strata (canopy, sub-canopy, shrubs, herbaceous, moss/ground-cover) that each cover 20% within the forested polygon</p> <p>Add the number of vegetation structures that qualify. If you have:</p> <table style="margin-left: auto; margin-right: auto;"> <tr> <td>4 structures or more</td> <td>points = 4</td> </tr> <tr> <td>3 structures</td> <td>points = 2</td> </tr> <tr> <td>2 structures</td> <td>points = 1</td> </tr> <tr> <td>1 structure</td> <td>points = 0</td> </tr> </table> <p>Map of Cowardin vegetation classes</p>	4 structures or more	points = 4	3 structures	points = 2	2 structures	points = 1	1 structure	points = 0	<p>Figure _____</p> <p style="font-size: 2em;">0</p>				
4 structures or more	points = 4												
3 structures	points = 2												
2 structures	points = 1												
1 structure	points = 0												
<p>H 1.2. Hydroperiods (see p. 73) Check the types of water regimes (hydroperiods) present within the wetland. The water regime has to cover more than 10% of the wetland or ¼ acre to count. (see text for descriptions of hydroperiods)</p> <table style="margin-left: auto; margin-right: auto;"> <tr> <td><input checked="" type="checkbox"/> Permanently flooded or inundated</td> <td>4 or more types present</td> <td>points = 3</td> </tr> <tr> <td><input type="checkbox"/> Seasonally flooded or inundated</td> <td>3 types present</td> <td>points = 2</td> </tr> <tr> <td><input type="checkbox"/> Occasionally flooded or inundated</td> <td>2 types present</td> <td>point = 1</td> </tr> <tr> <td><input type="checkbox"/> Saturated only</td> <td>1 type present</td> <td>points = 0</td> </tr> </table> <p><input type="checkbox"/> Permanently flowing stream or river in, or adjacent to, the wetland <input checked="" type="checkbox"/> Seasonally flowing stream in, or adjacent to, the wetland</p> <p><input type="checkbox"/> Lake-fringe wetland = 2 points <input type="checkbox"/> Freshwater tidal wetland = 2 points</p> <p style="text-align: right;">Map of hydroperiods</p>	<input checked="" type="checkbox"/> Permanently flooded or inundated	4 or more types present	points = 3	<input type="checkbox"/> Seasonally flooded or inundated	3 types present	points = 2	<input type="checkbox"/> Occasionally flooded or inundated	2 types present	point = 1	<input type="checkbox"/> Saturated only	1 type present	points = 0	<p>Figure _____</p> <p style="font-size: 2em;">2</p>
<input checked="" type="checkbox"/> Permanently flooded or inundated	4 or more types present	points = 3											
<input type="checkbox"/> Seasonally flooded or inundated	3 types present	points = 2											
<input type="checkbox"/> Occasionally flooded or inundated	2 types present	point = 1											
<input type="checkbox"/> Saturated only	1 type present	points = 0											
<p>H 1.3. Richness of Plant Species (see p. 75) Count the number of plant species in the wetland that cover at least 10 ft². (different patches of the same species can be combined to meet the size threshold) You do not have to name the species. Do not include Eurasian Milfoil, reed canarygrass, purple loosestrife, Canadian Thistle</p> <p style="text-align: center;">If you counted:</p> <table style="margin-left: auto; margin-right: auto;"> <tr> <td>> 19 species</td> <td>points = 2</td> </tr> <tr> <td style="background-color: yellow;">5 - 19 species</td> <td>points = 1</td> </tr> <tr> <td>< 5 species</td> <td>points = 0</td> </tr> </table> <p>List species below if you want to:</p>	> 19 species	points = 2	5 - 19 species	points = 1	< 5 species	points = 0	<p style="font-size: 2em;">1</p>						
> 19 species	points = 2												
5 - 19 species	points = 1												
< 5 species	points = 0												

Total for page 3

<p>H 1.4. Interspersion of habitats (see p. 76) Decide from the diagrams below whether interspersion between Cowardin vegetation classes (described in H 1.1), or the classes and unvegetated areas (can include open water or mudflats) is high, medium, low, or none.</p> <p>None = 0 points Low = 1 point Moderate = 2 points Moderate = 2 points</p> <p>High = 3 points High = 3 points High = 3 points</p> <p>[riparian braided channels]</p> <p>NOTE: If you have four or more classes or three vegetation classes and open water the rating is always “high”. Use map of Cowardin vegetation classes</p>	<p>Figure <u> </u></p> <p>1</p>
<p>H 1.5. Special Habitat Features: (see p. 77) <i>Check the habitat features that are present in the wetland. The number of checks is the number of points you put into the next column.</i></p> <p><input type="checkbox"/> Large, downed, woody debris within the wetland (>4in. diameter and 6 ft long).</p> <p><input type="checkbox"/> Standing snags (diameter at the bottom > 4 inches) in the wetland</p> <p><input type="checkbox"/> Undercut banks are present for at least 6.6 ft (2m) and/or overhanging vegetation extends at least 3.3 ft (1m) over a stream (or ditch) in, or contiguous with the unit, for at least 33 ft (10m)</p> <p><input type="checkbox"/> Stable steep banks of fine material that might be used by beaver or muskrat for denning (>30degree slope) OR signs of recent beaver activity are present (<i>cut shrubs or trees that have not yet turned grey/brown</i>)</p> <p><input type="checkbox"/> At least ¼ acre of thin-stemmed persistent vegetation or woody branches are present in areas that are permanently or seasonally inundated. (<i>structures for egg-laying by amphibians</i>)</p> <p><input checked="" type="checkbox"/> Invasive plants cover less than 25% of the wetland area in each stratum of plants</p> <p>NOTE: The 20% stated in early printings of the manual on page 78 is an error.</p>	<p>1</p>
<p align="center">H 1. TOTAL Score - potential for providing habitat <i>Add the scores from H1.1, H1.2, H1.3, H1.4, H1.5</i></p>	<p align="center">5</p>

Comments

H 2.3 Near or adjacent to other priority habitats listed by WDFW (see new and complete descriptions of WDFW priority habitats, and the counties in which they can be found, in the PHS report <http://wdfw.wa.gov/hab/phslist.htm>)

Which of the following priority habitats are within 330ft (100m) of the wetland unit? *NOTE: the connections do not have to be relatively undisturbed.*

- Aspen Stands:** Pure or mixed stands of aspen greater than 0.4 ha (1 acre).
- Biodiversity Areas and Corridors:** Areas of habitat that are relatively important to various species of native fish and wildlife (*full descriptions in WDFW PHS report p. 152*).
- Herbaceous Balds:** Variable size patches of grass and forbs on shallow soils over bedrock.
- Old-growth/Mature forests:** (Old-growth west of Cascade crest) Stands of at least 2 tree species, forming a multi-layered canopy with occasional small openings; with at least 20 trees/ha (8 trees/acre) > 81 cm (32 in) dbh or > 200 years of age. (Mature forests) Stands with average diameters exceeding 53 cm (21 in) dbh; crown cover may be less than 100%; crown cover may be less than 100%; decay, decadence, numbers of snags, and quantity of large downed material is generally less than that found in old-growth; 80 - 200 years old west of the Cascade crest.
- Oregon white Oak:** Woodlands Stands of pure oak or oak/conifer associations where canopy coverage of the oak component is important (*full descriptions in WDFW PHS report p. 158*).
- Riparian:** The area adjacent to aquatic systems with flowing water that contains elements of both aquatic and terrestrial ecosystems which mutually influence each other.
- Westside Prairies:** Herbaceous, non-forested plant communities that can either take the form of a dry prairie or a wet prairie (*full descriptions in WDFW PHS report p. 161*).
- Instream:** The combination of physical, biological, and chemical processes and conditions that interact to provide functional life history requirements for instream fish and wildlife resources.
- Nearshore:** Relatively undisturbed nearshore habitats. These include Coastal Nearshore, Open Coast Nearshore, and Puget Sound Nearshore. (*full descriptions of habitats and the definition of relatively undisturbed are in WDFW report: pp. 167-169 and glossary in Appendix A*).
- Caves:** A naturally occurring cavity, recess, void, or system of interconnected passages under the earth in soils, rock, ice, or other geological formations and is large enough to contain a human.
- Cliffs:** Greater than 7.6 m (25 ft) high and occurring below 5000 ft.
- Talus:** Homogenous areas of rock rubble ranging in average size 0.15 - 2.0 m (0.5 - 6.5 ft), composed of basalt, andesite, and/or sedimentary rock, including riprap slides and mine tailings. May be associated with cliffs.
- Snags and Logs:** Trees are considered snags if they are dead or dying and exhibit sufficient decay characteristics to enable cavity excavation/use by wildlife. Priority snags have a diameter at breast height of > 51 cm (20 in) in western Washington and are > 2 m (6.5 ft) in height. Priority logs are > 30 cm (12 in) in diameter at the largest end, and > 6 m (20 ft) long.

If wetland has **3 or more** priority habitats = **4 points**

If wetland has **2** priority habitats = **3 points**

If wetland has **1** priority habitat = **1 point**

No habitats = 0 points

Note: All vegetated wetlands are by definition a priority habitat but are not included in this list. Nearby wetlands are addressed in question H 2.4)

3

<p>H 2.4 <u>Wetland Landscape</u> (<i>choose the one description of the landscape around the wetland that best fits</i>) (<i>see p. 84</i>)</p> <p>There are at least 3 other wetlands within ½ mile, and the connections between them are relatively undisturbed (light grazing between wetlands OK, as is lake shore with some boating, but connections should NOT be bisected by paved roads, fill, fields, or other development. points = 5</p> <p>The wetland is Lake-fringe on a lake with little disturbance and there are 3 other lake-fringe wetlands within ½ mile points = 5</p> <p>There are at least 3 other wetlands within ½ mile, BUT the connections between them are disturbed points = 3</p> <p>The wetland is Lake-fringe on a lake with disturbance and there are 3 other lake-fringe wetland within ½ mile points = 3</p> <p>There is at least 1 wetland within ½ mile. points = 2</p> <p>There are no wetlands within ½ mile. points = 0</p>	3
<p>H 2. TOTAL Score - opportunity for providing habitat <i>Add the scores from H2.1, H2.2, H2.3, H2.4</i></p>	7
<p>TOTAL for H 1 from page 14</p>	5
<p>Total Score for Habitat Functions – add the points for H 1, H 2 and record the result on p. 1</p>	12

CATEGORIZATION BASED ON SPECIAL CHARACTERISTICS

Please determine if the wetland meets the attributes described below and circle the appropriate answers and Category.

Wetland Type <i>Check off any criteria that apply to the wetland. Circle the Category when the appropriate criteria are met.</i>	Category
SC 1.0 Estuarine wetlands (see p. 86) Does the wetland unit meet the following criteria for Estuarine wetlands? <ul style="list-style-type: none"> — The dominant water regime is tidal, — Vegetated, and — With a salinity greater than 0.5 ppt. YES = Go to SC 1.1 NO <u>X</u>	
SC 1.1 Is the wetland unit within a National Wildlife Refuge, National Park, National Estuary Reserve, Natural Area Preserve, State Park or Educational, Environmental, or Scientific Reserve designated under WAC 332-30-151? YES = Category I X NO go to SC 1.2	Cat. I
SC 1.2 Is the wetland unit at least 1 acre in size and meets at least two of the following three conditions? YES = Category I NO = Category II <ul style="list-style-type: none"> — The wetland is relatively undisturbed (has no diking, ditching, filling, cultivation, grazing, and has less than 10% cover of non-native plant species. If the non-native <i>Spartina</i> spp. are the only species that cover more than 10% of the wetland, then the wetland should be given a dual rating (I/II). The area of <i>Spartina</i> would be rated a Category II while the relatively undisturbed upper marsh with native species would be a Category I. Do not, however, exclude the area of <i>Spartina</i> in determining the size threshold of 1 acre. — At least ¾ of the landward edge of the wetland has a 100 ft buffer of shrub, forest, or un-grazed or un-mowed grassland. — The wetland has at least 2 of the following features: tidal channels, depressions with open water, or contiguous freshwater wetlands. 	Cat. I Cat. II Dual rating I/II

<p>SC 2.0 Natural Heritage Wetlands (<i>see p. 87</i>) Natural Heritage wetlands have been identified by the Washington Natural Heritage Program/DNR as either high quality undisturbed wetlands or wetlands that support state Threatened, Endangered, or Sensitive plant species.</p> <p>SC 2.1 Is the wetland unit being rated in a Section/Township/Range that contains a Natural Heritage wetland? (<i>this question is used to screen out most sites before you need to contact WNHP/DNR</i>) S/T/R information from Appendix D <input checked="" type="checkbox"/> or accessed from WNHP/DNR web site ___</p> <p>YES ___ – contact WNHP/DNR (see p. 79) and go to SC 2.2 NO <input checked="" type="checkbox"/></p> <p>SC 2.2 Has DNR identified the wetland as a high quality undisturbed wetland or as or as a site with state threatened or endangered plant species? YES = Category I NO <input checked="" type="checkbox"/> not a Heritage Wetland</p>	Cat. I
SC 3.0 Bogs (<i>see p. 87</i>)	
<p>Does the wetland unit (or any part of the unit) meet both the criteria for soils and vegetation in bogs? <i>Use the key below to identify if the wetland is a bog. If you answer yes you will still need to rate the wetland based on its functions.</i></p> <p>1. Does the unit have organic soil horizons (i.e. layers of organic soil), either peats or mucks, that compose 16 inches or more of the first 32 inches of the soil profile? (See Appendix B for a field key to identify organic soils)? Yes - go to Q. 3 <input checked="" type="checkbox"/> No - go to Q. 2</p> <p>2. Does the unit have organic soils, either peats or mucks that are less than 16 inches deep over bedrock, or an impermeable hardpan such as clay or volcanic ash, or that are floating on a lake or pond? Yes - go to Q. 3 <input checked="" type="checkbox"/> No - Is not a bog for purpose of rating</p> <p>3. Does the unit have more than 70% cover of mosses at ground level, AND other plants, if present, consist of the “bog” species listed in Table 3 as a significant component of the vegetation (more than 30% of the total shrub and herbaceous cover consists of species in Table 3)? Yes – Is a bog for purpose of rating <input checked="" type="checkbox"/> No - go to Q. 4</p> <p>NOTE: If you are uncertain about the extent of mosses in the understory you may substitute that criterion by measuring the pH of the water that seeps into a hole dug at least 16” deep. If the pH is less than 5.0 and the “bog” plant species in Table 3 are present, the wetland is a bog.</p> <p>1. Is the unit forested (> 30% cover) with sitka spruce, subalpine fir, western red cedar, western hemlock, lodgepole pine, quaking aspen, Englemann’s spruce, or western white pine, WITH any of the species (or combination of species) on the bog species plant list in Table 3 as a significant component of the ground cover (> 30% coverage of the total shrub/herbaceous cover)?</p> <p>2. YES = Category I No <input checked="" type="checkbox"/> Is not a bog for purpose of rating</p>	Cat. I

<p>SC 4.0 Forested Wetlands (see p. 90) Does the wetland unit have at least 1 acre of forest that meet one of these criteria for the Department of Fish and Wildlife’s forests as priority habitats? <i>If you answer yes you will still need to rate the wetland based on its functions.</i></p> <ul style="list-style-type: none"> — Old-growth forests: (west of Cascade crest) Stands of at least two tree species, forming a multi-layered canopy with occasional small openings; with at least 8 trees/acre (20 trees/hectare) that are at least 200 years of age OR have a diameter at breast height (dbh) of 32 inches (81 cm) or more. <p style="padding-left: 40px;">NOTE: The criterion for dbh is based on measurements for upland forests. Two-hundred year old trees in wetlands will often have a smaller dbh because their growth rates are often slower. The DFW criterion is and “OR” so old-growth forests do not necessarily have to have trees of this diameter.</p> <ul style="list-style-type: none"> — Mature forests: (west of the Cascade Crest) Stands where the largest trees are 80 – 200 years old OR have average diameters (dbh) exceeding 21 inches (53cm); crown cover may be less than 100%; decay, decadence, numbers of snags, and quantity of large downed material is generally less than that found in old-growth. <p>YES = Category I NO <input checked="" type="checkbox"/> not a forested wetland with special characteristics</p>	<p>Cat. I</p>
<p>SC 5.0 Wetlands in Coastal Lagoons (see p. 91) Does the wetland meet all of the following criteria of a wetland in a coastal lagoon?</p> <ul style="list-style-type: none"> — The wetland lies in a depression adjacent to marine waters that is wholly or partially separated from marine waters by sandbanks, gravel banks, shingle, or, less frequently, rocks — The lagoon in which the wetland is located contains surface water that is saline or brackish (> 0.5 ppt) during most of the year in at least a portion of the lagoon (<i>needs to be measured near the bottom</i>) <p>YES = Go to SC 5.1 NO <input checked="" type="checkbox"/> not a wetland in a coastal lagoon</p> <p>SC 5.1 Does the wetland meets all of the following three conditions?</p> <ul style="list-style-type: none"> — The wetland is relatively undisturbed (has no diking, ditching, filling, cultivation, grazing), and has less than 20% cover of invasive plant species (see list of invasive species on p. 74). — At least ¾ of the landward edge of the wetland has a 100 ft buffer of shrub, forest, or un-grazed or un-mowed grassland. — The wetland is larger than 1/10 acre (4350 square feet) <p style="text-align: center;">YES = Category I <input checked="" type="checkbox"/> NO = Category II</p>	<p>Cat. I</p> <p>Cat. II</p>

<p>SC 6.0 Interdunal Wetlands (<i>see p. 93</i>)</p> <p>Is the wetland unit west of the 1889 line (also called the Western Boundary of Upland Ownership or WBUO)?</p> <p>YES - go to SC 6.1 NO <input checked="" type="checkbox"/> not an interdunal wetland for rating</p> <p><i>If you answer yes you will still need to rate the wetland based on its functions.</i></p> <p>In practical terms that means the following geographic areas:</p> <ul style="list-style-type: none"> • Long Beach Peninsula- lands west of SR 103 • Grayland-Westport- lands west of SR 105 • Ocean Shores-Copalis- lands west of SR 115 and SR 109 <p>SC 6.1 Is the wetland one acre or larger, or is it in a mosaic of wetlands that is once acre or larger?</p> <p> YES = Category II <input checked="" type="checkbox"/> NO – go to SC 6.2</p> <p>SC 6.2 Is the unit between 0.1 and 1 acre, or is it in a mosaic of wetlands that is between 0.1 and 1 acre?</p> <p> YES = Category III</p>	<p>Cat. II</p> <p>Cat. III</p>
<p>Category of wetland based on Special Characteristics</p> <p><i>Choose the “highest” rating if wetland falls into several categories, and record on p. 1.</i></p> <p>If you answered NO for all types enter “Not Applicable” on p.1</p>	

WETLAND RATING FORM – WESTERN WASHINGTON
 Version 2 – Updated July 2006 to increase accuracy and reproducibility among users
 Updated Oct. 2008 with the new WDFW definitions for priority habitats

Name of wetland (if known): Mercer Slough

Date of site visit: February 6 & 21, 2013

Rated by: C. Douglas & J. Pursley Trained by Ecology? Yes No

Date of training: May 2007

SEC: 5 & 8

TOWNSHP: 24N

RNGE: 5E

Is S/T/R in Appendix D? Yes No

Map of wetland unit: Figure _____ Estimated size _____

SUMMARY OF RATING

Category based on FUNCTIONS provided by wetland: I II III IV

Category I =	Score > 70
Category II =	Score 51 - 69
Category III =	Score 30 – 50
Category IV =	Score < 30

Score for Water Quality Functions

20

Score for Hydrologic Functions

10

Score for Habitat Functions

27

TOTAL Score for Functions

57

Category based on SPECIAL CHARACTERISTICS of Wetland I II Does not apply

Final Category (choose the “highest” category from above”)

II

Summary of basic information about the wetland unit.

Wetland Unit has Special Characteristics		Wetland HGM Class used for Rating	
Estuarine	<input type="checkbox"/>	Depressional	<input checked="" type="checkbox"/>
Natural Heritage Wetland	<input type="checkbox"/>	Riverine	<input checked="" type="checkbox"/>
Bog	<input type="checkbox"/>	Lake-fringe	<input checked="" type="checkbox"/>
Mature Forest	<input type="checkbox"/>	Slope	<input checked="" type="checkbox"/>
Old Growth Forest	<input type="checkbox"/>	Flats	<input type="checkbox"/>
Coastal Lagoon	<input type="checkbox"/>	Freshwater Tidal	<input type="checkbox"/>
Interdunal	<input type="checkbox"/>		<input type="checkbox"/>
None of the above	<input checked="" type="checkbox"/>	Check if unit has multiple HGM classes present	<input checked="" type="checkbox"/>

Does the wetland being rated meet any of the criteria below? If you answer YES to any of the questions below you will need to protect the wetland according to the regulations regarding the special characteristics found in the wetland.

Check List for Wetlands that Need Additional Protection (in addition to the protection recommended for its category)	YES	NO
SP1. <i>Has the wetland unit been documented as a habitat for any Federally listed Threatened or Endangered animal or plant species (T/E species)?</i> For the purposes of this rating system, “documented” means the wetland is on the appropriate state or federal database.	<input checked="" type="checkbox"/>	<input type="checkbox"/>
SP2. <i>Has the wetland unit been documented as habitat for any State listed Threatened or Endangered animal species?</i> For the purposes of this rating system, “documented” means the wetland is on the appropriate state database. Note: Wetlands with State listed plant species are categorized as Category 1 Natural Heritage Wetlands (see p. 19 of data form).	<input checked="" type="checkbox"/>	<input type="checkbox"/>
SP3. <i>Does the wetland unit contain individuals of Priority species listed by the WDFW for the state?</i>	<input checked="" type="checkbox"/>	<input type="checkbox"/>
SP4. <i>Does the wetland unit have a local significance in addition to its functions?</i> For example, the wetland has been identified in the Shoreline Master Program, the Critical Areas Ordinance, or in a local management plan as having special significance.	<input checked="" type="checkbox"/>	<input type="checkbox"/>

To complete the next part of the data sheet you will need to determine the Hydrogeomorphic Class of the wetland being rated.

The hydrogeomorphic classification groups wetlands in to those that function in similar ways. This simplifies the questions needed to answer how well the wetland functions. The Hydrogeomorphic Class of a wetland can be determined using the key below. See p. 24 for more detailed instructions on classifying wetlands.

Classification of Vegetated Wetlands for Western Washington

If the hydrologic criteria listed in each question do not apply to the entire unit being rated, you probably have a unit with multiple HGM classes. In this case, identify which hydrologic criteria in questions 1-7 apply, and go to Question 8.

1. Are the water levels in the entire unit usually controlled by tides (i.e. except during floods)?
 NO – go to 2 YES – the wetland class is **Tidal Fringe**
 If yes, is the salinity of the water during periods of annual low flow below 0.5 ppt (parts per thousand)?
 YES – **Freshwater Tidal Fringe** NO – **Saltwater Tidal Fringe (Estuarine)**
*If your wetland can be classified as a Freshwater Tidal Fringe use the forms for **Riverine** wetlands. If it is a Saltwater Tidal Fringe it is rated as an **Estuarine** wetland. Wetlands that were call estuarine in the first and second editions of the rating system are called Salt Water Tidal Fringe in the Hydrogeomorphic Classification. Estuarine wetlands were categorized separately in the earlier editions, and this separation is being kept in this revision. To maintain consistency between editions, the term “Estuarine” wetland is kept. Please note, however, that the characteristics that define Category I and II estuarine wetlands have changed (see p. _____).*
-
2. The entire wetland unit is flat and precipitation is only source (>90%) of water to it. Groundwater and surface water runoff are NOT sources of water to the unit.
 NO – go to 3 YES – The wetland class is **Flats**
 If your wetland can be classified as a “Flats” wetland, use the form for **Depressional** wetlands.
-
3. Does the entire wetland meet both of the following criteria?
 The vegetated part of the wetland is on the shores of a body of permanent open water (without any vegetation on the surface) where at least 20 acres (8ha) in size;
 At least 30% of the open water area is deeper than 6.6 (2 m)?
 NO – go to 4 YES – The wetland class is **Lake-fringe (Lacustrine Fringe)**
-
4. Does the entire wetland meet all of the following criteria?
 The wetland is on a slope (*slope can be very gradual*).
 The water flows through the wetland in one direction (unidirectional) and usually comes from seeps. It may flow subsurface, as sheetflow, or in a swale without distinct banks.
 The water leaves the wetland **without being impounded**?
 NOTE: *Surface water does not pond in these types of wetlands except occasionally in very small and shallow depressions or behind hummocks (depressions are usually <3 ft diameter and less than 1 foot deep).*
 NO – go to 5 YES – The wetland class is **Slope**
-
5. Does the entire wetland meet all of the following criteria?
 The unit is in a valley or stream channel where it gets inundated by overbank flooding from that stream or river.
 The overbank flooding occurs at least once every two years.
 NOTE: *The riverine unit can contain depressions that are filled with water when the river is not flooding..*
 NO – go to 6 YES – The wetland class is **Riverine**
-
6. Is the entire wetland unit in a topographic depression in which water ponds, or is saturated to the surface, at some time of the year. This means that any outlet, if present is higher than the interior of the wetland.
 NO – go to 7 YES – The wetland class is **Depressional**
-
7. Is the entire wetland located in a very flat area with no obvious depression and no overbank flooding. The unit does not pond surface water more than a few inches. The unit seems to be maintained by high groundwater in the area. The wetland may be ditched, but has no obvious natural outlet.
 No – go to 8 YES – The wetland class is **Depressional**
-
8. Your wetland unit seems to be difficult to classify and probably contains several different HGM classes. For example, seeps at the base of a slope may grade into a riverine floodplain, or a small stream within a depressional wetland has a zone of flooding along its sides. GO BACK AND IDENTIFY WHICH OF THE HYDROLOGIC REGIMES DESCRIBED IN QUESTIONS 1-7 APPLY TO DIFFERENT AREAS IN THE UNIT (make a rough sketch to help you decide). Use the following table to identify the appropriate class to use for the rating system if you have several HGM classes present within your wetland. NOTE: Use this table only if the class that is recommended in the second column represents 10% or more of the total area of the wetland unit being rated. If the area of the class listed in column 2 is less than 10% of the unit, classify the wetland using the class that represents more than 90% of the total area.

HGM Classes within the wetland unit being rated	HGM Class to Use in Rating
Slope + Riverine	Riverine
Slope + Depressional	Depressional
Slope + Lake-fringe	Lake-fringe
Depressional + Riverine along stream within boundary	Depressional
Depressional + Lake-fringe	Depressional
Salt Water Tidal Fringe and any other class of freshwater wetland	Treat as ESTUARINE under wetlands with special characteristics

If you are unable still to determine which of the above criteria apply to your wetland, or you have more than 2 HGM classes within a wetland boundary, classify the wetland as **Depressional** for the rating.

H 2	Does the wetland have the <u>opportunity</u> to provide habitat for many species?	(only 1 score per box)
	<p>H 2.1 <u>Buffers</u> (see P. 80): Choose the description that best represents condition of buffer of wetland unit. The highest scoring criterion that applies to the wetland is to be used in the rating. See text for definition of "undisturbed".</p> <p><input type="checkbox"/> 100m (330 ft) of relatively undisturbed vegetated areas, rocky areas, or open water > 95% of circumference. No structures are within the undisturbed part of buffer (relatively undisturbed also means no grazing, no landscaping, no daily human use)..... points = 5</p> <p><input type="checkbox"/> 100m (330 ft) of relatively undisturbed vegetated areas, rocky areas, or open water > 50% circumference points = 4</p> <p><input type="checkbox"/> 50m (170 ft) of relatively undisturbed vegetated areas, rocky areas, or open water > 95% circumference points = 4</p> <p><input type="checkbox"/> 100m (330 ft) of relatively undisturbed vegetated areas, rocky areas, or open water > 25% circumference points = 3</p> <p><input type="checkbox"/> 50m (170 ft) of relatively undisturbed vegetated areas, rocky areas, or open water for > 50% circumference points = 3</p> <p>If buffer does not meet any of the criteria above:</p> <p><input type="checkbox"/> No paved areas (except paved trails) or buildings within 25m (80 ft) of wetland > 95% circumference. Light to moderate grazing or lawns are OK points = 2</p> <p><input type="checkbox"/> No paved areas of buildings within 50m of wetland for > 50% circumference. Light to moderate grazing or lawns are OK points = 2</p> <p><input type="checkbox"/> Heavy grazing in buffer points = 1</p> <p><input type="checkbox"/> Vegetated buffers are < 2m wide (6.6 ft) for more than 95% circumference (e.g. tilled fields, paving, basalt bedrock extend to edge of wetland) points = 0</p> <p><input checked="" type="checkbox"/> Buffer does not meet any of the criteria above points = 1</p> <p style="text-align: right;">Arial photo showing buffers</p>	<p>Figure <input type="checkbox"/></p> <p style="text-align: right;">1</p>
	<p>H 2.2 <u>Corridors and Connections</u> (see p. 81)</p> <p>H 2.2.1 Is the wetland part of a relatively undisturbed and unbroken vegetated corridor (either riparian or upland) that is at least 150 ft. wide, has at least a 30% cover of shrubs, forest or native undisturbed prairie, that connects to estuaries, other wetlands or undisturbed uplands that are at least 250 acres in size? (<i>Dams in riparian corridors, heavily used gravel roads, paved roads, are considered breaks in the corridor.</i>)</p> <p style="padding-left: 40px;"><input type="checkbox"/> YES = 4 points (go to H 2.3) <input checked="" type="checkbox"/> NO = go to H 2.2.2</p> <p>H. 2.2.2 Is the wetland part of a relatively undisturbed and unbroken vegetated corridor (either riparian or upland) that is at least 50 ft. wide, has at least 30% cover of shrubs or forest, and connects to estuaries, other wetlands or undisturbed uplands that are at least 25 acres in size? OR a Lake-fringe wetland, if it does not have an undisturbed corridor as in the question above?</p> <p style="padding-left: 40px;"><input checked="" type="checkbox"/> YES = 2 points (go to H 2.3) <input type="checkbox"/> NO = go to H 2.2.3</p> <p>H. 2.2.3 Is the wetland:</p> <ul style="list-style-type: none"> • Within 5 mi (8km) of a brackish or salt water estuary OR • Within 3 miles of a large field or pasture (> 40 acres) OR • Within 1 mile of a lake greater than 20 acres? <p style="text-align: right; padding-right: 40px;"><input type="checkbox"/> YES = 1 point <input type="checkbox"/> NO = 0 points</p>	<p style="text-align: right;">2</p>

Comments: _____

	<p>H 2.3 <u>Near or adjacent to other priority habitats listed by WDFW</u> (see p. 82): (see new and complete descriptions of WDFW priority habitats, and the counties in which they can be found, in the PHS report http://wdfw.wa.gov/hab/phslist.htm) Which of the following priority habitats are within 330 ft. (100m) of the wetland unit? <i>NOTE: the connections do not have to be relatively undisturbed.</i></p> <p><input type="checkbox"/> Aspen Stands: Pure or mixed stands of aspen greater than 0.4 ha (1 acre).</p> <p><input checked="" type="checkbox"/> Biodiversity Areas and Corridors: Areas of habitat that are relatively important to various species of native fish and wildlife (full descriptions in WDFW PHS report p. 152).</p> <p><input type="checkbox"/> Herbaceous Balds: Variable size patches of grass and forbs on shallow soils over bedrock.</p> <p><input type="checkbox"/> Old-growth/Mature forests: (Old-growth west of Cascade crest) Stands of at least 2 tree species, forming a multi-layered canopy with occasional small openings; with at least 20 trees/ha (8 trees/acre) > 81 cm (32 in) dbh or > 200 years of age. (Mature forests) Stands with average diameters exceeding 53 cm (21 in) dbh; crown cover may be less than 100%; decay, decadence, numbers of snags, and quantity of large downed material is generally less than that found in old-growth; 80 - 200 years old west of the Cascade crest.</p> <p><input type="checkbox"/> Oregon white Oak: Woodlands Stands of pure oak or oak/conifer associations where canopy coverage of the oak component is important (full descriptions in WDFW PHS report p. 158).</p> <p><input checked="" type="checkbox"/> Riparian: The area adjacent to aquatic systems with flowing water that contains elements of both aquatic and terrestrial ecosystems which mutually influence each other.</p> <p><input type="checkbox"/> Westside Prairies: Herbaceous, non-forested plant communities that can either take the form of a dry prairie or a wet prairie (full descriptions in WDFW PHS report p. 161).</p> <p><input checked="" type="checkbox"/> Instream: The combination of physical, biological, and chemical processes and conditions that interact to provide functional life history requirements for instream fish and wildlife resources.</p> <p><input type="checkbox"/> Nearshore: Relatively undisturbed nearshore habitats. These include Coastal Nearshore, Open Coast Nearshore, and Puget Sound Nearshore. (full descriptions of habitats and the definition of relatively undisturbed are in WDFW report: pp. 167-169 and glossary in Appendix A).</p> <p><input type="checkbox"/> Caves: A naturally occurring cavity, recess, void, or system of interconnected passages under the earth in soils, rock, ice, or other geological formations and is large enough to contain a human.</p> <p><input type="checkbox"/> Cliffs: Greater than 7.6 m (25 ft) high and occurring below 5000 ft.</p> <p><input type="checkbox"/> Talus: Homogenous areas of rock rubble ranging in average size 0.15 - 2.0 m (0.5 - 6.5 ft), composed of basalt, andesite, and/or sedimentary rock, including riprap slides and mine tailings. May be associated with cliffs.</p> <p><input checked="" type="checkbox"/> Snags and Logs: Trees are considered snags if they are dead or dying and exhibit sufficient decay characteristics to enable cavity excavation/use by wildlife. Priority snags have a diameter at breast height of > 51 cm (20 in) in western Washington and are > 2 m (6.5 ft) in height. Priority logs are > 30 cm (12 in) in diameter at the largest end, and > 6 m (20 ft) long.</p> <p style="text-align: right;">If wetland has 3 or more priority habitats = 4 points If wetland has 2 priority habitats = 3 points If wetland has 1 priority habitat = 1 point No habitats = 0 points</p> <p>Note: All vegetated wetlands are by definition a priority habitat but are not included in this list. Nearby wetlands are addressed in question H 2.4)</p>	4
	<p>H 2.4 <u>Wetland Landscape:</u> Choose the one description of the landscape around the wetland that best fits (see p. 84)</p> <ul style="list-style-type: none"> • There are at least 3 other wetlands within 1/2 mile, and the connections between them are relatively undisturbed (light grazing between wetlands OK, as is lake shore with some boating, but connections should NOT be bisected by paved roads, fill, fields, or other development.... points = 5 <input type="checkbox"/> • The wetland is Lake-fringe on a lake with little disturbance and there are 3 other lake-fringe wetlands within 1/2 mile points = 5 <input type="checkbox"/> • There are at least 3 other wetlands within 1/2 mile, BUT the connections between them are disturbed. points = 3 <input type="checkbox"/> • The wetland fringe on a lake with disturbance and there are 3 other lake-fringe wetlands within 1/2 mile points = 3 <input checked="" type="checkbox"/> • There is at least 1 wetland within 1/2 mile points = 2 <input type="checkbox"/> • There are no wetlands within 1/2 mile..... points = 0 <input type="checkbox"/> 	3
<p>H 2 TOTAL Score – opportunity for providing habitat Add the scores from H2.1, H2.2, H2.3, H2.4</p>		10
<p style="text-align: right;"><i>TOTAL for H 1 from page 8</i></p>		17
<p>◆ Total Score for Habitat Functions Add the points for H 1 and H 2; then record the result on p. 1</p>		27

Comments: _____

CATEGORIZATION BASED ON SPECIAL CHARACTERISTICS

Please determine if the wetland meets the attributes described below and circle the appropriate answers and Category.

Wetland Type – Check off any criteria that apply to the wetland. Circle the Category when the appropriate criteria are met.	
SC1	<p>Estuarine wetlands? (see p.86)</p> <p>Does the wetland unit meet the following criteria for Estuarine wetlands?</p> <p><input type="checkbox"/> The dominant water regime is tidal, <input type="checkbox"/> Vegetated, and <input type="checkbox"/> With a salinity greater than 0.5 ppt.</p> <p style="text-align: center;"><input type="checkbox"/> YES = Go to SC 1.1 <input checked="" type="checkbox"/> NO</p>
	<p>SC 1.1 Is the wetland unit within a National Wildlife Refuge, National Park, National Estuary Reserve, Natural Area Preserve, State Park or Educational, Environmental, or Scientific Reserve designated under WAC 332-30-151? <input type="checkbox"/> YES = Category I <input type="checkbox"/> NO = go to SC 1.2</p>
	<p>SC 1.2 Is the wetland at least 1 acre in size and meets at least two of the following conditions?</p> <p style="text-align: center;"><input type="checkbox"/> YES = Category I <input type="checkbox"/> NO = Category II</p> <p><input type="checkbox"/> The wetland is relatively undisturbed (has no diking, ditching, filling, cultivation, grazing, and has less than 10% cover of non-native plant species. If the non-native <i>Spartina</i> spp. are only species that cover more than 10% of the wetland, then the wetland should be given a dual rating (I/II). The area of <i>Spartina</i> would be rated a Category II while the relatively undisturbed upper marsh with native species would be a Category I. Do not, however, exclude the area of <i>Spartina</i> in determining the size threshold of 1 acre.</p> <p><input type="checkbox"/> At least 3/4 of the landward edge of the wetland has a 100 ft. buffer of shrub, forest, or un-grazed or un-mowed grassland</p> <p><input type="checkbox"/> The wetland has at least 2 of the following features: tidal channels, depressions with open water, or contiguous freshwater wetlands.</p>
SC2	<p>Natural Heritage Wetlands (see p. 87)</p> <p>Natural Heritage wetlands have been identified by the Washington Natural Heritage Program/DNR as either high quality undisturbed wetlands or wetlands that support state Threatened, Endangered, or Sensitive plant species.</p> <p>SC 2.1 Is the wetland being rated in a Section/Township/Range that contains a natural heritage wetland? (This question is used to screen out most sites before you need to contact WNHP/DNR.)</p> <p style="text-align: center;"><input type="checkbox"/> S/T/R information from Appendix D <input type="checkbox"/> or accessed from WNHP/DNR web site <input type="checkbox"/> YES Contact WNHP/DNR (see p. 79) and go to SC 2.2 <input checked="" type="checkbox"/> NO</p> <p>SC 2.2 Has DNR identified the wetland as a high quality undisturbed wetland or as a site with state threatened or endangered plant species?</p> <p style="text-align: center;"><input type="checkbox"/> YES = Category 1 <input checked="" type="checkbox"/> NO not a Heritage Wetland</p>
SC3	<p>Bogs (see p. 87)</p> <p>Does the wetland (or any part of the unit) meet both the criteria for soils and vegetation in bogs? Use the key below to identify if the wetland is a bog. If you answer yes you will still need to rate the wetland based on its function.</p> <p>1. Does the unit have organic soil horizons (i.e. layers of organic soil), either peats or mucks, that compose 16 inches or more of the first 32 inches of soil profile? (See Appendix B for a field key to identify organic soils)? <input type="checkbox"/> YES = go to question 3 <input checked="" type="checkbox"/> NO = go to question 2</p> <p>2. Does the wetland have organic soils, either peats or mucks that are less than 16 inches deep over bedrock, or an impermeable hardpan such as clay or volcanic ash, or that are floating on a lake or pond? <input type="checkbox"/> YES = go to question 3 <input checked="" type="checkbox"/> NO = is not a bog for purpose of rating</p> <p>3. Does the unit have more than 70% cover of mosses at ground level, AND other plants, if present, consist of the “bog” species listed in Table 3 as a significant component of the vegetation (more than 30% of the total shrub and herbaceous cover consists of species in Table 3)?</p> <p style="text-align: center;"><input type="checkbox"/> YES = Is a bog for purpose of rating <input checked="" type="checkbox"/> NO = go to question 4</p> <p>NOTE: If you are uncertain about the extent of mosses in the understory you may substitute that criterion by measuring the pH of the water that seeps into a hole dug at least 16” deep. If the pH is less than 5.0 and the “bog” plant species in Table 3 are present, the wetland is a bog.</p> <p>4. Is the unit forested (> 30% cover) with sitka spruce, subalpine fir, western red cedar, western hemlock, lodgepole pine, quaking aspen, Englemann’s spruce, or western white pine. WITH any of the species (or combination of species) on the bog species plant list in Table 3 as a significant component of the ground cover (> 30% coverage of the total shrub/herbaceous cover)?</p> <p style="text-align: center;"><input type="checkbox"/> YES = Category I <input checked="" type="checkbox"/> NO = Is not a bog for purpose of rating</p>
	<p>Cat. I <input type="checkbox"/></p>

SC4	<p>Forested Wetlands (see p. 90)</p> <p>Does the wetland have at least 1 acre of forest that meet one of these criteria for the Department of Fish and Wildlife's forests as priority habitats? <i>If you answer yes you will still need to rate the wetland based on its function.</i></p> <p><input type="checkbox"/> Old-growth forests: (west of Cascade Crest) Stands of at least two three species forming a multi-layered canopy with occasional small openings; with at least 8 trees/acre (20 trees/hectare) that are at least 200 years of age OR have a diameter at breast height (dbh) of 32 inches (81 cm or more). NOTE: The criterion for dbh is based on measurements for upland forests. Two-hundred year old trees in wetlands will often have a smaller dbh because their growth rates are often slower. The DFW criterion is and "OR" so old-growth forests do not necessarily have to have trees of this diameter.</p> <p><input type="checkbox"/> Mature forests: (west of the Cascade Crest) Stands where the largest trees are 80 – 200 years old OR have an average diameters (dbh) exceeding 21 inches (53 cm); crown cover may be less than 100%; decay, decadence, numbers of snags, and quantity of large downed material is generally less than that found in old-growth.</p> <p><input type="checkbox"/> YES = Category I <input checked="" type="checkbox"/> NO = not a forested wetland with special characteristics</p>	<p>Cat. I <input type="checkbox"/></p>
SC5	<p>Wetlands in Coastal Lagoons (see p. 91)</p> <p>Does the wetland meet all of the following criteria of a wetland in a coastal lagoon?</p> <p><input type="checkbox"/> The wetland lies in a depression adjacent to marine waters that is wholly or partially separated from marine waters by sandbanks, gravel banks, shingle, or, less frequently, rocks.</p> <p><input type="checkbox"/> The lagoon in which the wetland is located contains surface water that is saline or brackish (> 0.5 ppt) during most of the year in at least a portion of the lagoon (<i>needs to be measured near the bottom.</i>)</p> <p><input type="checkbox"/> YES = Go to SC 5.1 <input checked="" type="checkbox"/> NO not a wetland in a coastal lagoon</p> <p>SC 5.1 Does the wetland meet all of the following three conditions?</p> <p><input type="checkbox"/> The wetland is relatively undisturbed (has no diking, ditching, filling, cultivation, grazing) and has less than 20% cover of invasive plant species (see list of invasive species on p. 74).</p> <p><input type="checkbox"/> At least 3/4 of the landward edge of the wetland has a 100 ft. buffer of shrub, forest, or un-grazed or un-mowed grassland.</p> <p><input type="checkbox"/> The wetland is larger than 1/10 acre (4350 square ft.)</p> <p><input type="checkbox"/> YES = Category I <input type="checkbox"/> NO = Category II</p>	<p>Cat. I <input type="checkbox"/></p> <p>Cat. II <input type="checkbox"/></p>
SC6	<p>Interdunal Wetlands (see p. 93)</p> <p>Is the wetland west of the 1889 line (also called the Western Boundary of Upland Ownership or WBUO)?</p> <p><input type="checkbox"/> YES = Go to SC 6.1 <input checked="" type="checkbox"/> NO not an interdunal wetland for rating</p> <p><i>If you answer yes you will still need to rate the wetland based on its functions.</i></p> <p>In practical terms that means the following geographic areas:</p> <ul style="list-style-type: none"> • Long Beach Peninsula -- lands west of SR 103 • Grayland-Westport -- lands west of SR 105 • Ocean Shores-Copalis – lands west of SR 115 and SR 109 <p>SC 6.1 Is the wetland one acre or larger, or is it in a mosaic of wetlands that is one acre or larger?</p> <p><input type="checkbox"/> YES = Category II <input type="checkbox"/> NO = go to SC 6.2</p> <p>SC 6.2 Is the wetland between 0.1 and 1 acre, or is it in a mosaic of wetlands that is between 0.1 and 1 acre?</p> <p><input type="checkbox"/> YES = Category III</p>	<p>Cat. II <input type="checkbox"/></p> <p>Cat. III <input type="checkbox"/></p>
◆	<p>Category of wetland based on Special Characteristics</p> <p><i>Choose the "highest" rating if wetland falls into several categories, and record on p. 1.</i></p> <p>If you answered NO for all types enter "Not Applicable" on p. 1</p>	<p>NA</p>

Comments:

WETLAND RATING FORM – WESTERN WASHINGTON
Version 2 – Updated July 2006 to increase accuracy and reproducibility among users
Updated Oct. 2008 with the new WDFW definitions for priority habitats

Name of wetland (if known): North Lake

Date of site visit: February 14, 2013

Rated by: C. Douglas & J. Pursley Trained by Ecology? Yes No

Date of training: May 2007

SEC: 29 TOWNSHP: 24N RNGE: 5E

Is S/T/R in Appendix D? Yes No

Map of wetland unit: Figure _____ Estimated size _____

SUMMARY OF RATING

Category based on FUNCTIONS provided by wetland: I II III IV

Category I =	Score > 70
Category II =	Score 51 - 69
Category III =	Score 30 – 50
Category IV =	Score < 30

Score for Water Quality Functions

8

Score for Hydrologic Functions

4

Score for Habitat Functions

10

TOTAL Score for Functions

22

Category based on SPECIAL CHARACTERISTICS of Wetland I II Does not apply

Final Category (choose the “highest” category from above”)

IV

Summary of basic information about the wetland unit.

Wetland Unit has Special Characteristics		Wetland HGM Class used for Rating	
Estuarine	<input type="checkbox"/>	Depressional	<input type="checkbox"/>
Natural Heritage Wetland	<input type="checkbox"/>	Riverine	<input type="checkbox"/>
Bog	<input type="checkbox"/>	Lake-fringe	<input type="checkbox"/>
Mature Forest	<input type="checkbox"/>	Slope	<input checked="" type="checkbox"/>
Old Growth Forest	<input type="checkbox"/>	Flats	<input type="checkbox"/>
Coastal Lagoon	<input type="checkbox"/>	Freshwater Tidal	<input type="checkbox"/>
Interdunal	<input type="checkbox"/>		<input type="checkbox"/>
None of the above	<input checked="" type="checkbox"/>	Check if unit has multiple HGM classes present	<input type="checkbox"/>

Does the wetland being rated meet any of the criteria below? If you answer YES to any of the questions below you will need to protect the wetland according to the regulations regarding the special characteristics found in the wetland.

Check List for Wetlands that Need Additional Protection (in addition to the protection recommended for its category)	YES	NO
SP1. <i>Has the wetland unit been documented as a habitat for any Federally listed Threatened or Endangered animal or plant species (T/E species)?</i> For the purposes of this rating system, “documented” means the wetland is on the appropriate state or federal database.	<input type="checkbox"/>	<input checked="" type="checkbox"/>
SP2. <i>Has the wetland unit been documented as habitat for any State listed Threatened or Endangered animal species?</i> For the purposes of this rating system, “documented” means the wetland is on the appropriate state database. Note: Wetlands with State listed plant species are categorized as Category 1 Natural Heritage Wetlands (see p. 19 of data form).	<input type="checkbox"/>	<input checked="" type="checkbox"/>
SP3. <i>Does the wetland unit contain individuals of Priority species listed by the WDFW for the state?</i>	<input type="checkbox"/>	<input checked="" type="checkbox"/>
SP4. <i>Does the wetland unit have a local significance in addition to its functions?</i> For example, the wetland has been identified in the Shoreline Master Program, the Critical Areas Ordinance, or in a local management plan as having special significance.	<input type="checkbox"/>	<input checked="" type="checkbox"/>

To complete the next part of the data sheet you will need to determine the Hydrogeomorphic Class of the wetland being rated.

The hydrogeomorphic classification groups wetlands in to those that function in similar ways. This simplifies the questions needed to answer how well the wetland functions. The Hydrogeomorphic Class of a wetland can be determined using the key below. See p. 24 for more detailed instructions on classifying wetlands.

Classification of Vegetated Wetlands for Western Washington

If the hydrologic criteria listed in each question do not apply to the entire unit being rated, you probably have a unit with multiple HGM classes. In this case, identify which hydrologic criteria in questions 1-7 apply, and go to Question 8.

1. Are the water levels in the entire unit usually controlled by tides (i.e. except during floods)?
 NO – go to 2 YES – the wetland class is **Tidal Fringe**
 If yes, is the salinity of the water during periods of annual low flow below 0.5 ppt (parts per thousand)?
 YES – **Freshwater Tidal Fringe** NO – **Saltwater Tidal Fringe (Estuarine)**
*If your wetland can be classified as a Freshwater Tidal Fringe use the forms for **Riverine** wetlands. If it is a Saltwater Tidal Fringe it is rated as an **Estuarine** wetland. Wetlands that were call estuarine in the first and second editions of the rating system are called Salt Water Tidal Fringe in the Hydrogeomorphic Classification. Estuarine wetlands were categorized separately in the earlier editions, and this separation is being kept in this revision. To maintain consistency between editions, the term “Estuarine” wetland is kept. Please note, however, that the characteristics that define Category I and II estuarine wetlands have changed (see p. _____).*
-
2. The entire wetland unit is flat and precipitation is only source (>90%) of water to it. Groundwater and surface water runoff are NOT sources of water to the unit.
 NO – go to 3 YES – The wetland class is **Flats**
 If your wetland can be classified as a “Flats” wetland, use the form for **Depressional** wetlands.
-
3. Does the entire wetland meet both of the following criteria?
 The vegetated part of the wetland is on the shores of a body of permanent open water (without any vegetation on the surface) where at least 20 acres (8ha) in size;
 At least 30% of the open water area is deeper than 6.6 (2 m)?
 NO – go to 4 YES – The wetland class is **Lake-fringe (Lacustrine Fringe)**
-
4. Does the entire wetland meet all of the following criteria?
 The wetland is on a slope (*slope can be very gradual*).
 The water flows through the wetland in one direction (unidirectional) and usually comes from seeps. It may flow subsurface, as sheetflow, or in a swale without distinct banks.
 The water leaves the wetland **without being impounded?**
 NOTE: *Surface water does not pond in these types of wetlands except occasionally in very small and shallow depressions or behind hummocks (depressions are usually <3 ft diameter and less than 1 foot deep).*
 NO – go to 5 YES – The wetland class is **Slope**
-
5. Does the entire wetland meet all of the following criteria?
 The unit is in a valley or stream channel where it gets inundated by overbank flooding from that stream or river.
 The overbank flooding occurs at least once every two years.
 NOTE: *The riverine unit can contain depressions that are filled with water when the river is not flooding..*
 NO – go to 6 YES – The wetland class is **Riverine**
-
6. Is the entire wetland unit in a topographic depression in which water ponds, or is saturated to the surface, at some time of the year. This means that any outlet, if present is higher than the interior of the wetland.
 NO – go to 7 YES – The wetland class is **Depressional**
-
7. Is the entire wetland located in a very flat area with no obvious depression and no overbank flooding. The unit does not pond surface water more than a few inches. The unit seems to be maintained by high groundwater in the area. The wetland may be ditched, but has no obvious natural outlet.
 No – go to 8 YES – The wetland class is **Depressional**
-
8. Your wetland unit seems to be difficult to classify and probably contains several different HGM classes. For example, seeps at the base of a slope may grade into a riverine floodplain, or a small stream within a depressional wetland has a zone of flooding along its sides. GO BACK AND IDENTIFY WHICH OF THE HYDROLOGIC REGIMES DESCRIBED IN QUESTIONS 1-7 APPLY TO DIFFERENT AREAS IN THE UNIT (make a rough sketch to help you decide). Use the following table to identify the appropriate class to use for the rating system if you have several HGM classes present within your wetland. NOTE: Use this table only if the class that is recommended in the second column represents 10% or more of the total area of the wetland unit being rated. If the area of the class listed in column 2 is less than 10% of the unit, classify the wetland using the class that represents more than 90% of the total area.

HGM Classes within the wetland unit being rated	HGM Class to Use in Rating
Slope + Riverine	Riverine
Slope + Depressional	Depressional
Slope + Lake-fringe	Lake-fringe
Depressional + Riverine along stream within boundary	Depressional
Depressional + Lake-fringe	Depressional
Salt Water Tidal Fringe and any other class of freshwater wetland	Treat as ESTUARINE under wetlands with special characteristics

If you are unable still to determine which of the above criteria apply to your wetland, or you have more than 2 HGM classes within a wetland boundary, classify the wetland as **Depressional** for the rating.

S Slope Wetlands		Points
WATER QUALITY FUNCTIONS – Indicators that wetland functions to improve water quality.		(only 1 score per box) (see p.64)
S 1	Does the wetland have the <u>potential</u> to improve water quality?	
	S 1.1 Characteristics of average slope of unit: • Slope is 1% or less (a 1% slope has a 1 ft. vertical drop in elevation for every 100 ft. horizontal distance)..... points = 3 <input type="checkbox"/> • Slope is 1% - 2% points = 2 <input type="checkbox"/> • Slope is 2% - 5% points = 1 <input checked="" type="checkbox"/> • Slope is greater than 5% points = 0 <input type="checkbox"/>	1
	S 1.2 The soil 2 inches below the surface (or duff layer) is clay, organic (Use NRCS definitions). <input type="checkbox"/> YES = 3 points <input checked="" type="checkbox"/> NO = 0 points	0
	S 1.3 Characteristics of the vegetation in the wetland that trap sediments and pollutants: Choose the points appropriate for the description that best fits the vegetation in the wetland. Dense vegetation means you have trouble seeing the soil surface (>75% cover), and uncut means not grazed or mowed and plants are higher than 6 inches. • Dense, uncut, herbaceous vegetation > 90% of the wetland area..... points = 6 <input type="checkbox"/> • Dense, uncut, herbaceous vegetation > 1/2 of area points = 3 <input checked="" type="checkbox"/> • Dense, woody, vegetation > 1/2 of area..... points = 2 <input type="checkbox"/> • Dense, uncut, herbaceous vegetation > 1/4 of area points = 1 <input type="checkbox"/> • Does not meet any of the criteria above for vegetation points = 0 <input type="checkbox"/>	Figure <input type="checkbox"/> 3
Aerial photo or map with vegetation polygons		
Total for S 1 Add the points in the boxes above		4
S 2	Does the wetland have the <u>opportunity</u> to improve water quality?	(see p. 67)
	Answer YES if you know or believe there are pollutants in groundwater or surface water coming into the wetland that would otherwise reduce water quality in streams, lakes or groundwater downgradient from the wetland? Note which of the following conditions provide the sources of pollutants. A unit may have pollutants coming from several sources, but any single source would qualify as opportunity. <input type="checkbox"/> Grazing in the wetland or within 150 ft <input checked="" type="checkbox"/> Untreated stormwater discharges to wetland <input checked="" type="checkbox"/> Tilled fields, logging, or orchards within 150 ft. of wetland <input checked="" type="checkbox"/> Residential, urban areas, or golf courses are within 150 ft. upslope of wetland <input type="checkbox"/> Other <input checked="" type="checkbox"/> YES multiplier is 2 <input type="checkbox"/> NO multiplier is 1	Multiplier 2
◆ TOTAL – Water Quality Functions Multiply the score from S1 by S2; then add score to table on p. 1		8
HYDROLOGIC FUNCTIONS – Indicators that wetland functions to reduce flooding and stream erosion.		
S 3	Does the wetland have the <u>potential</u> to reduce flooding and stream erosion?	(see p.68)
	S 3.1 Characteristics of vegetation that reduce the velocity of surface flows during storms: Choose the points appropriate for the description that best fits conditions in the wetland (stems of plants should be thick enough (usually > 1/8in), or dense enough to remain erect during surface flows). • Dense, uncut, rigid vegetation covers > 90% of the area of the wetland points = 6 <input type="checkbox"/> • Dense, uncut, rigid vegetation > 1/2 area of wetland..... points = 3 <input type="checkbox"/> • Dense, uncut, rigid vegetation > 1/4 area..... points = 1 <input type="checkbox"/> • More than 1/4 of area is grazed, mowed, tilled, or vegetation is not rigid points = 0 <input checked="" type="checkbox"/>	0
	S 3.2 Characteristics of slope wetland that holds back small amounts of flood flows. The slope has small surface depressions that can retain water over at least 10% of its area. <input checked="" type="checkbox"/> YES = 2 points <input type="checkbox"/> NO = 0 points	2
Add the points in the boxes above		2
S 4	Does the wetland have the <u>opportunity</u> to reduce flooding and erosion?	(see p. 70)
	Is the wetland in a landscape position where the reduction in water velocity it provides helps protect downstream property and aquatic resources from flooding or excessive and/or erosive flows? Note which of the following conditions apply. <input checked="" type="checkbox"/> Wetland has surface runoff that drains to a river or stream that has flooding problems <input type="checkbox"/> Other (Answer NO if the major source of water is controlled by a reservoir (e.g. wetland is a seep that is on the downstream side of a dam) <input checked="" type="checkbox"/> YES multiplier is 2 <input type="checkbox"/> NO multiplier is 1	Multiplier 2
◆ TOTAL – Hydrologic Functions Multiply the score from S3 by S4; then add score to table on p. 1		4

Comments: _____

These questions apply to wetlands of all HGM classes.		Points																
HABITAT FUNCTIONS – Indicators that wetland functions to provide important habitat.		(only 1 score per box)																
H 1	Does the wetland have the potential to provide habitat for many species?																	
H 1.1	<p>Vegetation structure (see P. 72): Check the types of vegetation classes present (as defined by Cowardin) – Size threshold for each class is 1/4 acre or more than 10% of the area if unit is smaller than 2.5 acres.</p> <p><input type="checkbox"/> Aquatic Bed <input checked="" type="checkbox"/> Emergent plants <input checked="" type="checkbox"/> Scrub/shrub (areas where shrubs have > 30% cover) <input checked="" type="checkbox"/> Forested (areas where trees have > 30% cover)</p> <p>If the unit has a forested class check if: <input type="checkbox"/> The forested class has 3 out of 5 strata (canopy, sub-canopy, shrubs, herbaceous, moss/ground-cover) that each cover 20% within the forested polygon.</p> <p>Add the number of vegetation types that qualify. If you have:</p> <table border="0"> <tr> <td>4 structures or more..... points = 4</td> <td><input type="checkbox"/></td> <td>Map of Cowardin vegetation classes</td> <td></td> </tr> <tr> <td>3 structures..... points = 2</td> <td><input checked="" type="checkbox"/></td> <td>3 structures..... points = 2</td> <td><input checked="" type="checkbox"/></td> </tr> <tr> <td>2 structures..... points = 1</td> <td><input type="checkbox"/></td> <td>1 structure..... points = 0</td> <td><input type="checkbox"/></td> </tr> </table>	4 structures or more..... points = 4	<input type="checkbox"/>	Map of Cowardin vegetation classes		3 structures..... points = 2	<input checked="" type="checkbox"/>	3 structures..... points = 2	<input checked="" type="checkbox"/>	2 structures..... points = 1	<input type="checkbox"/>	1 structure..... points = 0	<input type="checkbox"/>	<p>Figure <input type="checkbox"/></p> <p style="text-align: right;">2</p>				
4 structures or more..... points = 4	<input type="checkbox"/>	Map of Cowardin vegetation classes																
3 structures..... points = 2	<input checked="" type="checkbox"/>	3 structures..... points = 2	<input checked="" type="checkbox"/>															
2 structures..... points = 1	<input type="checkbox"/>	1 structure..... points = 0	<input type="checkbox"/>															
H 1.2	<p>Hydroperiods (see p.73): Check the types of water regimes (hydroperiods) present within the wetland. The water regime has to cover more than 10% of the wetland or 1/4 acre to count (see text for descriptions of hydroperiods).</p> <table border="0"> <tr> <td><input type="checkbox"/> Permanently flooded or inundated</td> <td>4 or more types present</td> <td>points = 3</td> <td><input type="checkbox"/></td> </tr> <tr> <td><input checked="" type="checkbox"/> Seasonally flooded or inundated</td> <td>3 or more types present</td> <td>points = 2</td> <td><input type="checkbox"/></td> </tr> <tr> <td><input checked="" type="checkbox"/> Occasionally flooded or inundated</td> <td>2 types present</td> <td>points = 1</td> <td><input checked="" type="checkbox"/></td> </tr> <tr> <td><input checked="" type="checkbox"/> Saturated only</td> <td>1 type present</td> <td>points = 0</td> <td><input type="checkbox"/></td> </tr> </table> <p><input type="checkbox"/> Permanently flowing stream or river in, or adjacent to, the wetland <input type="checkbox"/> Seasonally flowing stream in, or adjacent to, the wetland</p> <p><input type="checkbox"/> Lake-fringe wetland..... = 2 points <input type="checkbox"/> Freshwater tidal wetland..... = 2 points</p> <p style="text-align: right;">Map of hydroperiods</p>	<input type="checkbox"/> Permanently flooded or inundated	4 or more types present	points = 3	<input type="checkbox"/>	<input checked="" type="checkbox"/> Seasonally flooded or inundated	3 or more types present	points = 2	<input type="checkbox"/>	<input checked="" type="checkbox"/> Occasionally flooded or inundated	2 types present	points = 1	<input checked="" type="checkbox"/>	<input checked="" type="checkbox"/> Saturated only	1 type present	points = 0	<input type="checkbox"/>	<p>Figure <input type="checkbox"/></p> <p style="text-align: right;">1</p>
<input type="checkbox"/> Permanently flooded or inundated	4 or more types present	points = 3	<input type="checkbox"/>															
<input checked="" type="checkbox"/> Seasonally flooded or inundated	3 or more types present	points = 2	<input type="checkbox"/>															
<input checked="" type="checkbox"/> Occasionally flooded or inundated	2 types present	points = 1	<input checked="" type="checkbox"/>															
<input checked="" type="checkbox"/> Saturated only	1 type present	points = 0	<input type="checkbox"/>															
H 1.3	<p>Richness of Plant Species (see p. 75): Count the number of plant species in the wetland that cover at least 10 ft² (different patches of the same species can be combined to meet the size threshold) You do not have to name the species. Do not include Eurasian Milfoil, reed canarygrass, purple loosestrife, Canadian Thistle.</p> <p>If you counted:</p> <table border="0"> <tr> <td>> 19 species..... points = 2</td> <td><input type="checkbox"/></td> </tr> <tr> <td>5 – 19 species..... points = 1</td> <td><input checked="" type="checkbox"/></td> </tr> <tr> <td>< 5 species..... points = 0</td> <td><input type="checkbox"/></td> </tr> </table> <p>List species below if you want to:</p> <hr/>	> 19 species..... points = 2	<input type="checkbox"/>	5 – 19 species..... points = 1	<input checked="" type="checkbox"/>	< 5 species..... points = 0	<input type="checkbox"/>	<p style="text-align: right;">1</p>										
> 19 species..... points = 2	<input type="checkbox"/>																	
5 – 19 species..... points = 1	<input checked="" type="checkbox"/>																	
< 5 species..... points = 0	<input type="checkbox"/>																	
H 1.4	<p>Interspersion of Habitats (see p. 76): Decided from the diagrams below whether interspersion between Cowardin vegetation (described in H1.1), or the classes and unvegetated areas (can include open water or mudflats) is high, medium, low, or none.</p> <div style="text-align: center;"> <p>None = 0 points Low = 1 point Moderate = 2 points</p> <p>High = 3 points [riparian braided channels]</p> </div> <p>Note: If you have 4 or more classes or 3 vegetation classes and open water, the rating is always “high”.</p> <p style="text-align: right;">Use map of Cowardin classes.</p>	<p>Figure <input type="checkbox"/></p> <p style="text-align: right;">2</p>																
H 1.5	<p>Special Habitat Features (see p. 77): Check the habitat features that are present in the wetland. The number of checks is the number of points you put into the next column.</p> <p><input type="checkbox"/> Large, downed, woody debris within the wetland (> 4 in. diameter and 6 ft. long) <input type="checkbox"/> Standing snags (diameter at the bottom > 4 inches) in the wetland <input type="checkbox"/> Undercut banks are present for at least 6.6 ft. (2m) and/or overhanging vegetation extends at least 3.3 ft. (1m) over a stream (or ditch) in, or contiguous with the unit, for at least 33 ft. (10m) <input type="checkbox"/> Stable steep banks of fine material that might be used by beaver or muskrat for denning (> 30 degree slope) OR signs of recent beaver activity are present (cut shrubs or trees that have not yet turned grey/brown) <input type="checkbox"/> At least 1/4 acre of thin-stemmed persistent vegetation or woody branches are present in areas that are permanently or seasonally inundated (structures for egg-laying by amphibians) <input type="checkbox"/> Invasive plants cover less than 25% of the wetland area in each stratum of plants</p> <p>NOTE: The 20% stated in early printings of the manual on page 78 is an error.</p>	<p style="text-align: right;">0</p>																
H 1 TOTAL Score – potential for providing habitat		6																
Add the points in the column above																		

H 2	Does the wetland have the <u>opportunity</u> to provide habitat for many species?	(only 1 score per box)
	<p>H 2.1 <u>Buffers</u> (see P. 80): Choose the description that best represents condition of buffer of wetland unit. The highest scoring criterion that applies to the wetland is to be used in the rating. See text for definition of "undisturbed".</p> <p><input type="checkbox"/> 100m (330 ft) of relatively undisturbed vegetated areas, rocky areas, or open water > 95% of circumference. No structures are within the undisturbed part of buffer (relatively undisturbed also means no grazing, no landscaping, no daily human use)..... points = 5</p> <p><input type="checkbox"/> 100m (330 ft) of relatively undisturbed vegetated areas, rocky areas, or open water > 50% circumference points = 4</p> <p><input type="checkbox"/> 50m (170 ft) of relatively undisturbed vegetated areas, rocky areas, or open water > 95% circumference points = 4</p> <p><input type="checkbox"/> 100m (330 ft) of relatively undisturbed vegetated areas, rocky areas, or open water > 25% circumference points = 3</p> <p><input type="checkbox"/> 50m (170 ft) of relatively undisturbed vegetated areas, rocky areas, or open water for > 50% circumference points = 3</p> <p>If buffer does not meet any of the criteria above:</p> <p><input type="checkbox"/> No paved areas (except paved trails) or buildings within 25m (80 ft) of wetland > 95% circumference. Light to moderate grazing or lawns are OK points = 2</p> <p><input type="checkbox"/> No paved areas of buildings within 50m of wetland for > 50% circumference. Light to moderate grazing or lawns are OK points = 2</p> <p><input type="checkbox"/> Heavy grazing in buffer points = 1</p> <p><input type="checkbox"/> Vegetated buffers are < 2m wide (6.6 ft) for more than 95% circumference (e.g. tilled fields, paving, basalt bedrock extend to edge of wetland) points = 0</p> <p><input checked="" type="checkbox"/> Buffer does not meet any of the criteria above points = 1</p> <p style="text-align: right;">Arial photo showing buffers</p>	<p>Figure <input type="checkbox"/></p> <p style="text-align: right;">1</p>
	<p>H 2.2 <u>Corridors and Connections</u> (see p. 81)</p> <p>H 2.2.1 Is the wetland part of a relatively undisturbed and unbroken vegetated corridor (either riparian or upland) that is at least 150 ft. wide, has at least a 30% cover of shrubs, forest or native undisturbed prairie, that connects to estuaries, other wetlands or undisturbed uplands that are at least 250 acres in size? (<i>Dams in riparian corridors, heavily used gravel roads, paved roads, are considered breaks in the corridor.</i>)</p> <p style="padding-left: 40px;"><input type="checkbox"/> YES = 4 points (go to H 2.3) <input checked="" type="checkbox"/> NO = go to H 2.2.2</p> <p>H. 2.2.2 Is the wetland part of a relatively undisturbed and unbroken vegetated corridor (either riparian or upland) that is at least 50 ft. wide, has at least 30% cover of shrubs or forest, and connects to estuaries, other wetlands or undisturbed uplands that are at least 25 acres in size? OR a Lake-fringe wetland, if it does not have an undisturbed corridor as in the question above?</p> <p style="padding-left: 40px;"><input type="checkbox"/> YES = 2 points (go to H 2.3) <input checked="" type="checkbox"/> NO = go to H 2.2.3</p> <p>H. 2.2.3 Is the wetland:</p> <ul style="list-style-type: none"> • Within 5 mi (8km) of a brackish or salt water estuary OR • Within 3 miles of a large field or pasture (> 40 acres) OR • Within 1 mile of a lake greater than 20 acres? <p style="text-align: right; padding-right: 40px;"><input type="checkbox"/> YES = 1 point <input checked="" type="checkbox"/> NO = 0 points</p>	<p style="text-align: right;">0</p>

Comments: _____

	<p>H 2.3 <u>Near or adjacent to other priority habitats listed by WDFW</u> (see p. 82): (see new and complete descriptions of WDFW priority habitats, and the counties in which they can be found, in the PHS report http://wdfw.wa.gov/hab/phslist.htm) Which of the following priority habitats are within 330 ft. (100m) of the wetland unit? <i>NOTE: the connections do not have to be relatively undisturbed.</i></p> <p><input type="checkbox"/> Aspen Stands: Pure or mixed stands of aspen greater than 0.4 ha (1 acre).</p> <p><input type="checkbox"/> Biodiversity Areas and Corridors: Areas of habitat that are relatively important to various species of native fish and wildlife (full descriptions in WDFW PHS report p. 152).</p> <p><input type="checkbox"/> Herbaceous Balds: Variable size patches of grass and forbs on shallow soils over bedrock.</p> <p><input type="checkbox"/> Old-growth/Mature forests: (Old-growth west of Cascade crest) Stands of at least 2 tree species, forming a multi-layered canopy with occasional small openings; with at least 20 trees/ha (8 trees/acre) > 81 cm (32 in) dbh or > 200 years of age. (Mature forests) Stands with average diameters exceeding 53 cm (21 in) dbh; crown cover may be less than 100%; decay, decadence, numbers of snags, and quantity of large downed material is generally less than that found in old-growth; 80 - 200 years old west of the Cascade crest.</p> <p><input type="checkbox"/> Oregon white Oak: Woodlands Stands of pure oak or oak/conifer associations where canopy coverage of the oak component is important (full descriptions in WDFW PHS report p. 158).</p> <p><input type="checkbox"/> Riparian: The area adjacent to aquatic systems with flowing water that contains elements of both aquatic and terrestrial ecosystems which mutually influence each other.</p> <p><input type="checkbox"/> Westside Prairies: Herbaceous, non-forested plant communities that can either take the form of a dry prairie or a wet prairie (full descriptions in WDFW PHS report p. 161).</p> <p><input type="checkbox"/> Instream: The combination of physical, biological, and chemical processes and conditions that interact to provide functional life history requirements for instream fish and wildlife resources.</p> <p><input type="checkbox"/> Nearshore: Relatively undisturbed nearshore habitats. These include Coastal Nearshore, Open Coast Nearshore, and Puget Sound Nearshore. (full descriptions of habitats and the definition of relatively undisturbed are in WDFW report: pp. 167-169 and glossary in Appendix A).</p> <p><input type="checkbox"/> Caves: A naturally occurring cavity, recess, void, or system of interconnected passages under the earth in soils, rock, ice, or other geological formations and is large enough to contain a human.</p> <p><input type="checkbox"/> Cliffs: Greater than 7.6 m (25 ft) high and occurring below 5000 ft.</p> <p><input type="checkbox"/> Talus: Homogenous areas of rock rubble ranging in average size 0.15 - 2.0 m (0.5 - 6.5 ft), composed of basalt, andesite, and/or sedimentary rock, including riprap slides and mine tailings. May be associated with cliffs.</p> <p><input type="checkbox"/> Snags and Logs: Trees are considered snags if they are dead or dying and exhibit sufficient decay characteristics to enable cavity excavation/use by wildlife. Priority snags have a diameter at breast height of > 51 cm (20 in) in western Washington and are > 2 m (6.5 ft) in height. Priority logs are > 30 cm (12 in) in diameter at the largest end, and > 6 m (20 ft) long.</p> <p style="text-align: right;">If wetland has 3 or more priority habitats = 4 points If wetland has 2 priority habitats = 3 points If wetland has 1 priority habitat = 1 point No habitats = 0 points</p> <p>Note: All vegetated wetlands are by definition a priority habitat but are not included in this list. Nearby wetlands are addressed in question H 2.4)</p>	0
	<p>H 2.4 <u>Wetland Landscape:</u> Choose the one description of the landscape around the wetland that best fits (see p. 84)</p> <ul style="list-style-type: none"> • There are at least 3 other wetlands within 1/2 mile, and the connections between them are relatively undisturbed (light grazing between wetlands OK, as is lake shore with some boating, but connections should NOT be bisected by paved roads, fill, fields, or other development.... points = 5 <input type="checkbox"/> • The wetland is Lake-fringe on a lake with little disturbance and there are 3 other lake-fringe wetlands within 1/2 mile points = 5 <input type="checkbox"/> • There are at least 3 other wetlands within 1/2 mile, BUT the connections between them are disturbed. points = 3 <input checked="" type="checkbox"/> • The wetland fringe on a lake with disturbance and there are 3 other lake-fringe wetlands within 1/2 mile points = 3 <input type="checkbox"/> • There is at least 1 wetland within 1/2 mile points = 2 <input type="checkbox"/> • There are no wetlands within 1/2 mile..... points = 0 <input type="checkbox"/> 	3
	<p>H 2 TOTAL Score – opportunity for providing habitat Add the scores from H2.1, H2.2, H2.3, H2.4</p>	4
	<p style="text-align: right;">TOTAL for H 1 from page 8</p>	6
◆	<p>Total Score for Habitat Functions Add the points for H 1 and H 2; then record the result on p. 1</p>	10

Comments: _____

CATEGORIZATION BASED ON SPECIAL CHARACTERISTICS

Please determine if the wetland meets the attributes described below and circle the appropriate answers and Category.

Wetland Type – Check off any criteria that apply to the wetland. Circle the Category when the appropriate criteria are met.	
SC1	<p>Estuarine wetlands? (see p.86)</p> <p>Does the wetland unit meet the following criteria for Estuarine wetlands?</p> <p><input type="checkbox"/> The dominant water regime is tidal, <input type="checkbox"/> Vegetated, and <input type="checkbox"/> With a salinity greater than 0.5 ppt.</p> <p style="text-align: center;"><input type="checkbox"/> YES = Go to SC 1.1 <input checked="" type="checkbox"/> NO</p>
	<p>SC 1.1 Is the wetland unit within a National Wildlife Refuge, National Park, National Estuary Reserve, Natural Area Preserve, State Park or Educational, Environmental, or Scientific Reserve designated under WAC 332-30-151? <input type="checkbox"/> YES = Category I <input type="checkbox"/> NO = go to SC 1.2</p>
	<p>SC 1.2 Is the wetland at least 1 acre in size and meets at least two of the following conditions?</p> <p style="text-align: center;"><input type="checkbox"/> YES = Category I <input type="checkbox"/> NO = Category II</p> <p><input type="checkbox"/> The wetland is relatively undisturbed (has no diking, ditching, filling, cultivation, grazing, and has less than 10% cover of non-native plant species. If the non-native <i>Spartina</i> spp. are only species that cover more than 10% of the wetland, then the wetland should be given a dual rating (I/II). The area of <i>Spartina</i> would be rated a Category II while the relatively undisturbed upper marsh with native species would be a Category I. Do not, however, exclude the area of <i>Spartina</i> in determining the size threshold of 1 acre.</p> <p><input type="checkbox"/> At least 3/4 of the landward edge of the wetland has a 100 ft. buffer of shrub, forest, or un-grazed or un-mowed grassland</p> <p><input type="checkbox"/> The wetland has at least 2 of the following features: tidal channels, depressions with open water, or contiguous freshwater wetlands.</p>
SC2	<p>Natural Heritage Wetlands (see p. 87)</p> <p>Natural Heritage wetlands have been identified by the Washington Natural Heritage Program/DNR as either high quality undisturbed wetlands or wetlands that support state Threatened, Endangered, or Sensitive plant species.</p> <p>SC 2.1 Is the wetland being rated in a Section/Township/Range that contains a natural heritage wetland? (This question is used to screen out most sites before you need to contact WNHP/DNR.)</p> <p style="text-align: center;"><input type="checkbox"/> S/T/R information from Appendix D <input type="checkbox"/> or accessed from WNHP/DNR web site <input type="checkbox"/> YES Contact WNHP/DNR (see p. 79) and go to SC 2.2 <input checked="" type="checkbox"/> NO</p> <p>SC 2.2 Has DNR identified the wetland as a high quality undisturbed wetland or as a site with state threatened or endangered plant species?</p> <p style="text-align: center;"><input type="checkbox"/> YES = Category 1 <input checked="" type="checkbox"/> NO not a Heritage Wetland</p>
SC3	<p>Bogs (see p. 87)</p> <p>Does the wetland (or any part of the unit) meet both the criteria for soils and vegetation in bogs? Use the key below to identify if the wetland is a bog. If you answer yes you will still need to rate the wetland based on its function.</p> <ol style="list-style-type: none"> Does the unit have organic soil horizons (i.e. layers of organic soil), either peats or mucks, that compose 16 inches or more of the first 32 inches of soil profile? (See Appendix B for a field key to identify organic soils)? <input type="checkbox"/> YES = go to question 3 <input checked="" type="checkbox"/> NO = go to question 2 Does the wetland have organic soils, either peats or mucks that are less than 16 inches deep over bedrock, or an impermeable hardpan such as clay or volcanic ash, or that are floating on a lake or pond? <input type="checkbox"/> YES = go to question 3 <input checked="" type="checkbox"/> NO = is not a bog for purpose of rating Does the unit have more than 70% cover of mosses at ground level, AND other plants, if present, consist of the “bog” species listed in Table 3 as a significant component of the vegetation (more than 30% of the total shrub and herbaceous cover consists of species in Table 3)? <p style="text-align: center;"><input type="checkbox"/> YES = Is a bog for purpose of rating <input checked="" type="checkbox"/> NO = go to question 4</p> <p>NOTE: If you are uncertain about the extent of mosses in the understory you may substitute that criterion by measuring the pH of the water that seeps into a hole dug at least 16” deep. If the pH is less than 5.0 and the “bog” plant species in Table 3 are present, the wetland is a bog.</p> <ol style="list-style-type: none"> Is the unit forested (> 30% cover) with sitka spruce, subalpine fir, western red cedar, western hemlock, lodgepole pine, quaking aspen, Englemann’s spruce, or western white pine. WITH any of the species (or combination of species) on the bog species plant list in Table 3 as a significant component of the ground cover (> 30% coverage of the total shrub/herbaceous cover)? <p style="text-align: center;"><input type="checkbox"/> YES = Category I <input checked="" type="checkbox"/> NO = Is not a bog for purpose of rating</p>
	<p>Cat. I <input type="checkbox"/></p> <p>Cat. II <input type="checkbox"/></p> <p>Dual Rating I/II <input type="checkbox"/></p> <p>Cat I <input type="checkbox"/></p> <p>Cat. I <input type="checkbox"/></p>

SC4	<p>Forested Wetlands (see p. 90)</p> <p>Does the wetland have at least 1 acre of forest that meet one of these criteria for the Department of Fish and Wildlife’s forests as priority habitats? <i>If you answer yes you will still need to rate the wetland based on its function.</i></p> <p><input type="checkbox"/> Old-growth forests: (west of Cascade Crest) Stands of at least two three species forming a multi-layered canopy with occasional small openings; with at least 8 trees/acre (20 trees/hectare) that are at least 200 years of age OR have a diameter at breast height (dbh) of 32 inches (81 cm or more). NOTE: The criterion for dbh is based on measurements for upland forests. Two-hundred year old trees in wetlands will often have a smaller dbh because their growth rates are often slower. The DFW criterion is and “OR” so old-growth forests do not necessarily have to have trees of this diameter.</p> <p><input type="checkbox"/> Mature forests: (west of the Cascade Crest) Stands where the largest trees are 80 – 200 years old OR have an average diameters (dbh) exceeding 21 inches (53 cm); crown cover may be less than 100%; decay, decadence, numbers of snags, and quantity of large downed material is generally less than that found in old-growth.</p> <p><input type="checkbox"/> YES = Category I <input checked="" type="checkbox"/> NO = not a forested wetland with special characteristics</p>	<p>Cat. I <input type="checkbox"/></p>
SC5	<p>Wetlands in Coastal Lagoons (see p. 91)</p> <p>Does the wetland meet all of the following criteria of a wetland in a coastal lagoon?</p> <p><input type="checkbox"/> The wetland lies in a depression adjacent to marine waters that is wholly or partially separated from marine waters by sandbanks, gravel banks, shingle, or, less frequently, rocks.</p> <p><input type="checkbox"/> The lagoon in which the wetland is located contains surface water that is saline or brackish (> 0.5 ppt) during most of the year in at least a portion of the lagoon (<i>needs to be measured near the bottom.</i>)</p> <p><input type="checkbox"/> YES = Go to SC 5.1 <input checked="" type="checkbox"/> NO not a wetland in a coastal lagoon</p> <p>SC 5.1 Does the wetland meet all of the following three conditions?</p> <p><input type="checkbox"/> The wetland is relatively undisturbed (has no diking, ditching, filling, cultivation, grazing) and has less than 20% cover of invasive plant species (see list of invasive species on p. 74).</p> <p><input type="checkbox"/> At least 3/4 of the landward edge of the wetland has a 100 ft. buffer of shrub, forest, or un-grazed or un-mowed grassland.</p> <p><input type="checkbox"/> The wetland is larger than 1/10 acre (4350 square ft.)</p> <p><input type="checkbox"/> YES = Category I <input type="checkbox"/> NO = Category II</p>	<p>Cat. I <input type="checkbox"/></p> <p>Cat. II <input type="checkbox"/></p>
SC6	<p>Interdunal Wetlands (see p. 93)</p> <p>Is the wetland west of the 1889 line (also called the Western Boundary of Upland Ownership or WBUO)?</p> <p><input type="checkbox"/> YES = Go to SC 6.1 <input checked="" type="checkbox"/> NO not an interdunal wetland for rating</p> <p><i>If you answer yes you will still need to rate the wetland based on its functions.</i></p> <p>In practical terms that means the following geographic areas:</p> <ul style="list-style-type: none"> • Long Beach Peninsula -- lands west of SR 103 • Grayland-Westport -- lands west of SR 105 • Ocean Shores-Copalis – lands west of SR 115 and SR 109 <p>SC 6.1 Is the wetland one acre or larger, or is it in a mosaic of wetlands that is one acre or larger?</p> <p><input type="checkbox"/> YES = Category II <input type="checkbox"/> NO = go to SC 6.2</p> <p>SC 6.2 Is the wetland between 0.1 and 1 acre, or is it in a mosaic of wetlands that is between 0.1 and 1 acre?</p> <p><input type="checkbox"/> YES = Category III</p>	<p>Cat. II <input type="checkbox"/></p> <p>Cat. III <input type="checkbox"/></p>
◆	<p>Category of wetland based on Special Characteristics</p> <p><i>Choose the “highest” rating if wetland falls into several categories, and record on p. 1.</i></p> <p>If you answered NO for all types enter “Not Applicable” on p. 1</p>	<p>NA</p>

Comments:

WETLAND RATING FORM – WESTERN WASHINGTON
Version 2 – Updated July 2006 to increase accuracy and reproducibility among users
Updated Oct. 2008 with the new WDFW definitions for priority habitats

Name of wetland (if known): Uqwj "Ncmg

Date of site visit: February 14, 2013

Rated by: C. Douglas & J. Pursley Trained by Ecology? Yes No

Date of training: May 2007

SEC: 29 TOWNSHP: 24N RNGE: 5E

Is S/T/R in Appendix D? Yes No

Map of wetland unit: Figure _____ Estimated size _____

SUMMARY OF RATING

Category based on FUNCTIONS provided by wetland: I II III IV

Category I =	Score > 70
Category II =	Score 51 - 69
Category III =	Score 30 – 50
Category IV =	Score < 30

Score for Water Quality Functions	14
Score for Hydrologic Functions	16
Score for Habitat Functions	13
TOTAL Score for Functions	43

Category based on SPECIAL CHARACTERISTICS of Wetland I II Does not apply

Final Category (choose the “highest” category from above”)

III

Summary of basic information about the wetland unit.

Wetland Unit has Special Characteristics		Wetland HGM Class used for Rating	
Estuarine	<input type="checkbox"/>	Depressional	<input checked="" type="checkbox"/>
Natural Heritage Wetland	<input type="checkbox"/>	Riverine	<input type="checkbox"/>
Bog	<input type="checkbox"/>	Lake-fringe	<input type="checkbox"/>
Mature Forest	<input type="checkbox"/>	Slope	<input type="checkbox"/>
Old Growth Forest	<input type="checkbox"/>	Flats	<input type="checkbox"/>
Coastal Lagoon	<input type="checkbox"/>	Freshwater Tidal	<input type="checkbox"/>
Interdunal	<input type="checkbox"/>		<input type="checkbox"/>
None of the above	<input checked="" type="checkbox"/>	Check if unit has multiple HGM classes present	<input type="checkbox"/>

Does the wetland being rated meet any of the criteria below? If you answer YES to any of the questions below you will need to protect the wetland according to the regulations regarding the special characteristics found in the wetland.

Check List for Wetlands that Need Additional Protection (in addition to the protection recommended for its category)	YES	NO
SP1. <i>Has the wetland unit been documented as a habitat for any Federally listed Threatened or Endangered animal or plant species (T/E species)?</i> For the purposes of this rating system, “documented” means the wetland is on the appropriate state or federal database.	<input type="checkbox"/>	<input checked="" type="checkbox"/>
SP2. <i>Has the wetland unit been documented as habitat for any State listed Threatened or Endangered animal species?</i> For the purposes of this rating system, “documented” means the wetland is on the appropriate state database. Note: Wetlands with State listed plant species are categorized as Category 1 Natural Heritage Wetlands (see p. 19 of data form).	<input type="checkbox"/>	<input checked="" type="checkbox"/>
SP3. <i>Does the wetland unit contain individuals of Priority species listed by the WDFW for the state?</i>	<input type="checkbox"/>	<input checked="" type="checkbox"/>
SP4. <i>Does the wetland unit have a local significance in addition to its functions?</i> For example, the wetland has been identified in the Shoreline Master Program, the Critical Areas Ordinance, or in a local management plan as having special significance.	<input type="checkbox"/>	<input checked="" type="checkbox"/>

To complete the next part of the data sheet you will need to determine the Hydrogeomorphic Class of the wetland being rated.

The hydrogeomorphic classification groups wetlands in to those that function in similar ways. This simplifies the questions needed to answer how well the wetland functions. The Hydrogeomorphic Class of a wetland can be determined using the key below. See p. 24 for more detailed instructions on classifying wetlands.

Classification of Vegetated Wetlands for Western Washington

If the hydrologic criteria listed in each question do not apply to the entire unit being rated, you probably have a unit with multiple HGM classes. In this case, identify which hydrologic criteria in questions 1-7 apply, and go to Question 8.

1. Are the water levels in the entire unit usually controlled by tides (i.e. except during floods)?
 NO – go to 2 YES – the wetland class is **Tidal Fringe**
 If yes, is the salinity of the water during periods of annual low flow below 0.5 ppt (parts per thousand)?
 YES – **Freshwater Tidal Fringe** NO – **Saltwater Tidal Fringe (Estuarine)**
*If your wetland can be classified as a Freshwater Tidal Fringe use the forms for **Riverine** wetlands. If it is a Saltwater Tidal Fringe it is rated as an **Estuarine** wetland. Wetlands that were called estuarine in the first and second editions of the rating system are called Salt Water Tidal Fringe in the Hydrogeomorphic Classification. Estuarine wetlands were categorized separately in the earlier editions, and this separation is being kept in this revision. To maintain consistency between editions, the term “Estuarine” wetland is kept. Please note, however, that the characteristics that define Category I and II estuarine wetlands have changed (see p. _____).*
-
2. The entire wetland unit is flat and precipitation is only source (>90%) of water to it. Groundwater and surface water runoff are NOT sources of water to the unit.
 NO – go to 3 YES – The wetland class is **Flats**
 If your wetland can be classified as a “Flats” wetland, use the form for **Depressional** wetlands.
-
3. Does the entire wetland meet both of the following criteria?
 The vegetated part of the wetland is on the shores of a body of permanent open water (without any vegetation on the surface) where at least 20 acres (8ha) in size;
 At least 30% of the open water area is deeper than 6.6 (2 m)?
 NO – go to 4 YES – The wetland class is **Lake-fringe (Lacustrine Fringe)**
-
4. Does the entire wetland meet all of the following criteria?
 The wetland is on a slope (*slope can be very gradual*).
 The water flows through the wetland in one direction (unidirectional) and usually comes from seeps. It may flow subsurface, as sheetflow, or in a swale without distinct banks.
 The water leaves the wetland **without being impounded**?
 NOTE: *Surface water does not pond in these types of wetlands except occasionally in very small and shallow depressions or behind hummocks (depressions are usually <3 ft diameter and less than 1 foot deep).*
 NO – go to 5 YES – The wetland class is **Slope**
-
5. Does the entire wetland meet all of the following criteria?
 The unit is in a valley or stream channel where it gets inundated by overbank flooding from that stream or river.
 The overbank flooding occurs at least once every two years.
 NOTE: *The riverine unit can contain depressions that are filled with water when the river is not flooding..*
 NO – go to 6 YES – The wetland class is **Riverine**
-
6. Is the entire wetland unit in a topographic depression in which water ponds, or is saturated to the surface, at some time of the year. This means that any outlet, if present is higher than the interior of the wetland.
 NO – go to 7 YES – The wetland class is **Depressional**
-
7. Is the entire wetland located in a very flat area with no obvious depression and no overbank flooding. The unit does not pond surface water more than a few inches. The unit seems to be maintained by high groundwater in the area. The wetland may be ditched, but has no obvious natural outlet.
 No – go to 8 YES – The wetland class is **Depressional**
-
8. Your wetland unit seems to be difficult to classify and probably contains several different HGM classes. For example, seeps at the base of a slope may grade into a riverine floodplain, or a small stream within a depressional wetland has a zone of flooding along its sides. GO BACK AND IDENTIFY WHICH OF THE HYDROLOGIC REGIMES DESCRIBED IN QUESTIONS 1-7 APPLY TO DIFFERENT AREAS IN THE UNIT (make a rough sketch to help you decide). Use the following table to identify the appropriate class to use for the rating system if you have several HGM classes present within your wetland. NOTE: Use this table only if the class that is recommended in the second column represents 10% or more of the total area of the wetland unit being rated. If the area of the class listed in column 2 is less than 10% of the unit, classify the wetland using the class that represents more than 90% of the total area.

HGM Classes within the wetland unit being rated	HGM Class to Use in Rating
Slope + Riverine	Riverine
Slope + Depressional	Depressional
Slope + Lake-fringe	Lake-fringe
Depressional + Riverine along stream within boundary	Depressional
Depressional + Lake-fringe	Depressional
Salt Water Tidal Fringe and any other class of freshwater wetland	Treat as ESTUARINE under wetlands with special characteristics

If you are unable still to determine which of the above criteria apply to your wetland, or you have more than 2 HGM classes within a wetland boundary, classify the wetland as **Depressional** for the rating.

D Depressional and Flat Wetlands		Points
WATER QUALITY FUNCTIONS – Indicators that wetland functions to improve water quality.		(only 1 score per box) (see p.38)
D 1	Does the wetland have the <u>potential</u> to improve water quality?	
D 1.1	Characteristics of surface water flows out of the wetland: • Unit is a depression with no surface water leaving it (no outlet) points = 3 <input type="checkbox"/> • Unit has an intermittently flowing, OR highly constricted, permanently flowing outlet ... points = 2 <input checked="" type="checkbox"/> • Unit has an unconstricted, or slightly constricted, surface outlet (<i>permanently flowing</i>) .. points = 1 <input type="checkbox"/> • Unit is a “flat” depression (Q.7 on key), or in the Flats class, with permanent surface outflow and no obvious natural outlet and/or outlet is a man-made ditch..... points = 1 <input type="checkbox"/> <i>(If ditch is not permanently flowing treat unit as “intermittently flowing”)</i> Provide photo or drawing	Figure <input type="checkbox"/> 2
D 1.2	The soil 2 inches below the surface (or duff layer) is clay or organic (<i>use NRCS definitions</i>) YES points = 4 NO points = 0	0
D 1.3	Characteristics of persistent vegetation (emergent, shrub, and/or forest Cowardin class): • Wetland has persistent, ungrazed vegetation > = 95% of area..... points = 5 <input type="checkbox"/> • Wetland has persistent, ungrazed vegetation > = 1/2 of area..... points = 3 <input checked="" type="checkbox"/> • Wetland has persistent, ungrazed vegetation > = 1/10 of area..... points = 1 <input type="checkbox"/> • Wetland has persistent, ungrazed vegetation < 1/10 of area..... points = 0 <input type="checkbox"/> Map of Cowardin vegetation classes	Figure <input type="checkbox"/> 3
D 1.4	Characteristics of seasonal ponding or inundation: <i>This is the area of the wetland that is ponded for at least 2 months, but dries out sometime during the year. Do not count the area that is permanently ponded. Estimate area as the average condition 5 out of 10 years.</i> • Area seasonally ponded is > 1/2 total area of wetland points = 4 <input type="checkbox"/> • Area seasonally ponded is > 1/4 total area of wetland points = 2 <input checked="" type="checkbox"/> • Area seasonally ponded is < 1/4 total area of wetland points = 0 <input type="checkbox"/> Map of Hydroperiods	Figure <input type="checkbox"/> 2
Total for D 1		<i>Add the points in the boxes above</i> 7
D 2	Does the wetland have the <u>opportunity</u> to improve water quality?	(see p. 44)
Answer YES if you know or believe there are pollutants in groundwater or surface water coming into the wetland that would otherwise reduce water quality in streams, lakes or groundwater downgradient from the wetland? <i>Note which of the following conditions provide the sources of pollutants. A unit may have pollutants coming from several sources, but any single source would qualify as opportunity.</i> <input type="checkbox"/> Grazing in the wetland or within 150 ft <input checked="" type="checkbox"/> Untreated stormwater discharges to wetland <input type="checkbox"/> Tilled fields or orchards within 150 ft. of wetland <input type="checkbox"/> A stream or culvert discharges into wetland that drains developed areas, residential areas, farmed fields, roads, or clear-cut logging <input checked="" type="checkbox"/> Residential, urban areas, golf courses are within 150 ft. of wetland <input type="checkbox"/> Wetland is fed by groundwater high in phosphorus or nitrogen <input type="checkbox"/> Other _____		Multiplier 2
<input checked="" type="checkbox"/> YES multiplier is 2 <input type="checkbox"/> NO multiplier is 1		
◆ TOTAL – Water Quality Functions Multiply the score from D1 by D2; then <i>add score to table on p. 1</i>		14
HYDROLOGIC FUNCTIONS – Indicators that wetland unit functions to reduce flooding and stream degradation.		
D 3	Does the wetland have the <u>potential</u> to reduce flooding and erosion?	(see p.46)
D 3.1	Characteristics of surface water flows out of the wetland unit • Unit is a depression with no surface water leaving it (no outlet) points = 4 <input type="checkbox"/> • Unit has an intermittently flowing, OR highly constricted permanently flowing outlet points = 2 <input checked="" type="checkbox"/> • Unit is a “flat” depression (Q.7 on key) or in the Flats class, with permanent surface outflow and no obvious natural outlet and/or outlet is a man-made ditch..... points = 1 <input type="checkbox"/> <i>(If ditch is not permanently flowing treat unit as “intermittently flowing”)</i> • Unit has an unconstricted, or slightly constricted, surface outlet (<i>permanently flowing</i>) points = 0	2
D 3.2	Depth of storage during wet periods. <i>Estimate the height of ponding above the bottom of the outlet. For units with no outlet measure from the surface of permanent water or deepest part (if dry).</i> • Marks of ponding are 3 ft. or more above the surface or bottom of the outlet points = 7 <input type="checkbox"/> • The wetland is a “headwater” wetland..... points = 5 <input type="checkbox"/> • Marks of ponding between 2 ft. to < 3 ft. from surface or bottom of outlet..... points = 5 <input type="checkbox"/> • Marks are at least 0.5 ft. to < 2 ft. from surface or bottom of outlet..... points = 3 <input checked="" type="checkbox"/> • Wetland is flat (yes to Q.2 or Q.7 on key) but has small depressions on the surface that trap water . points = 1 <input type="checkbox"/> • Marks of ponding less than 0.5 ft points = 0 <input type="checkbox"/>	3
D 3.3	Contribution of wetland unit to storage in the watershed: <i>Estimate the ratio of the area of upstream basin contributing surface water to the wetland to the area of the wetland unit itself.</i> • The area of the basin is less than 10 times the area of unit..... points = 5 <input type="checkbox"/> • The area of the basin is 10 to 100 times the area of the unit..... points = 3 <input checked="" type="checkbox"/> • The area of the basin is more than 100 times the area of the unit points = 0 <input type="checkbox"/> • Entire unit is in the FLATS class points = 5 <input type="checkbox"/>	3
Total for D 3		<i>Add the points in the boxes above</i> 8

D 4	<p>Does the wetland have the <u>opportunity</u> to reduce flooding and erosion?</p> <p>Answer YES if the unit is in a location in the watershed where the flood storage, or reduction in water velocity, it provides helps protect downstream property and aquatic resources from flooding or excessive and/or erosive flows. Answer NO if the water coming into the wetland is controlled by a structure such as flood gate, tide gate, flap valve, reservoir etc. OR you estimate that more than 90% of the water in the wetland is from groundwater in areas where damaging groundwater flooding does not occur. <i>Note which of the following indicators of opportunity apply.</i></p> <p><input type="checkbox"/> Wetland is in a headwater of a river or stream that has flooding problems.</p> <p><input checked="" type="checkbox"/> Wetland drains to a river or stream that has flooding problems</p> <p><input type="checkbox"/> Wetland has no outlet and impounds surface runoff water that might otherwise flow into a river or stream that has flooding problems</p> <p><input type="checkbox"/> Other _____</p> <p><input checked="" type="checkbox"/> YES multiplier is 2 <input type="checkbox"/> NO multiplier is 1</p>	<p>(see p. 49)</p> <p>Multiplier</p> <p>2</p>
◆	<p>TOTAL – Hydrologic Functions Multiply the score from D3 by D4; then <i>add score to table on p. 1</i></p>	<p><u>16</u></p>

Comments: _____

H 2	Does the wetland have the <u>opportunity</u> to provide habitat for many species?	(only 1 score per box)
	<p>H 2.1 <u>Buffers</u> (see P. 80): Choose the description that best represents condition of buffer of wetland unit. The highest scoring criterion that applies to the wetland is to be used in the rating. See text for definition of "undisturbed".</p> <p><input type="checkbox"/> 100m (330 ft) of relatively undisturbed vegetated areas, rocky areas, or open water > 95% of circumference. No structures are within the undisturbed part of buffer (relatively undisturbed also means no grazing, no landscaping, no daily human use)..... points = 5</p> <p><input type="checkbox"/> 100m (330 ft) of relatively undisturbed vegetated areas, rocky areas, or open water > 50% circumference points = 4</p> <p><input type="checkbox"/> 50m (170 ft) of relatively undisturbed vegetated areas, rocky areas, or open water > 95% circumference points = 4</p> <p><input type="checkbox"/> 100m (330 ft) of relatively undisturbed vegetated areas, rocky areas, or open water > 25% circumference points = 3</p> <p><input type="checkbox"/> 50m (170 ft) of relatively undisturbed vegetated areas, rocky areas, or open water for > 50% circumference points = 3</p> <p>If buffer does not meet any of the criteria above:</p> <p><input type="checkbox"/> No paved areas (except paved trails) or buildings within 25m (80 ft) of wetland > 95% circumference. Light to moderate grazing or lawns are OK points = 2</p> <p><input type="checkbox"/> No paved areas of buildings within 50m of wetland for > 50% circumference. Light to moderate grazing or lawns are OK points = 2</p> <p><input type="checkbox"/> Heavy grazing in buffer points = 1</p> <p><input type="checkbox"/> Vegetated buffers are < 2m wide (6.6 ft) for more than 95% circumference (e.g. tilled fields, paving, basalt bedrock extend to edge of wetland) points = 0</p> <p><input checked="" type="checkbox"/> Buffer does not meet any of the criteria above points = 1</p> <p style="text-align: right;">Arial photo showing buffers</p>	<p>Figure <input type="checkbox"/></p> <p style="text-align: right;">1</p>
	<p>H 2.2 <u>Corridors and Connections</u> (see p. 81)</p> <p>H 2.2.1 Is the wetland part of a relatively undisturbed and unbroken vegetated corridor (either riparian or upland) that is at least 150 ft. wide, has at least a 30% cover of shrubs, forest or native undisturbed prairie, that connects to estuaries, other wetlands or undisturbed uplands that are at least 250 acres in size? (<i>Dams in riparian corridors, heavily used gravel roads, paved roads, are considered breaks in the corridor.</i>)</p> <p style="padding-left: 40px;"><input type="checkbox"/> YES = 4 points (go to H 2.3) <input checked="" type="checkbox"/> NO = go to H 2.2.2</p> <p>H. 2.2.2 Is the wetland part of a relatively undisturbed and unbroken vegetated corridor (either riparian or upland) that is at least 50 ft. wide, has at least 30% cover of shrubs or forest, and connects to estuaries, other wetlands or undisturbed uplands that are at least 25 acres in size? OR a Lake-fringe wetland, if it does not have an undisturbed corridor as in the question above?</p> <p style="padding-left: 40px;"><input type="checkbox"/> YES = 2 points (go to H 2.3) <input checked="" type="checkbox"/> NO = go to H 2.2.3</p> <p>H. 2.2.3 Is the wetland:</p> <ul style="list-style-type: none"> • Within 5 mi (8km) of a brackish or salt water estuary OR • Within 3 miles of a large field or pasture (> 40 acres) OR • Within 1 mile of a lake greater than 20 acres? <p style="text-align: right; padding-right: 40px;"><input type="checkbox"/> YES = 1 point <input checked="" type="checkbox"/> NO = 0 points</p>	<p style="text-align: right;">0</p>

Comments: _____

	<p>H 2.3 <u>Near or adjacent to other priority habitats listed by WDFW</u> (see p. 82): <i>(see new and complete descriptions of WDFW priority habitats, and the counties in which they can be found, in the PHS report http://wdfw.wa.gov/hab/phslist.htm)</i> Which of the following priority habitats are within 330 ft. (100m) of the wetland unit? NOTE: <i>the connections do not have to be relatively undisturbed.</i></p> <p><input type="checkbox"/> Aspen Stands: Pure or mixed stands of aspen greater than 0.4 ha (1 acre).</p> <p><input type="checkbox"/> Biodiversity Areas and Corridors: Areas of habitat that are relatively important to various species of native fish and wildlife <i>(full descriptions in WDFW PHS report p. 152).</i></p> <p><input type="checkbox"/> Herbaceous Balds: Variable size patches of grass and forbs on shallow soils over bedrock.</p> <p><input type="checkbox"/> Old-growth/Mature forests: (Old-growth west of Cascade crest) Stands of at least 2 tree species, forming a multi-layered canopy with occasional small openings; with at least 20 trees/ha (8 trees/acre) > 81 cm (32 in) dbh or > 200 years of age. (Mature forests) Stands with average diameters exceeding 53 cm (21 in) dbh; crown cover may be less than 100%; decay, decadence, numbers of snags, and quantity of large downed material is generally less than that found in old-growth; 80 - 200 years old west of the Cascade crest.</p> <p><input type="checkbox"/> Oregon white Oak: Woodlands Stands of pure oak or oak/conifer associations where canopy coverage of the oak component is important <i>(full descriptions in WDFW PHS report p. 158).</i></p> <p><input type="checkbox"/> Riparian: The area adjacent to aquatic systems with flowing water that contains elements of both aquatic and terrestrial ecosystems which mutually influence each other.</p> <p><input type="checkbox"/> Westside Prairies: Herbaceous, non-forested plant communities that can either take the form of a dry prairie or a wet prairie <i>(full descriptions in WDFW PHS report p. 161).</i></p> <p><input type="checkbox"/> Instream: The combination of physical, biological, and chemical processes and conditions that interact to provide functional life history requirements for instream fish and wildlife resources.</p> <p><input type="checkbox"/> Nearshore: Relatively undisturbed nearshore habitats. These include Coastal Nearshore, Open Coast Nearshore, and Puget Sound Nearshore. <i>(full descriptions of habitats and the definition of relatively undisturbed are in WDFW report: pp. 167-169 and glossary in Appendix A).</i></p> <p><input type="checkbox"/> Caves: A naturally occurring cavity, recess, void, or system of interconnected passages under the earth in soils, rock, ice, or other geological formations and is large enough to contain a human.</p> <p><input type="checkbox"/> Cliffs: Greater than 7.6 m (25 ft) high and occurring below 5000 ft.</p> <p><input type="checkbox"/> Talus: Homogenous areas of rock rubble ranging in average size 0.15 - 2.0 m (0.5 - 6.5 ft), composed of basalt, andesite, and/or sedimentary rock, including riprap slides and mine tailings. May be associated with cliffs.</p> <p><input checked="" type="checkbox"/> Snags and Logs: Trees are considered snags if they are dead or dying and exhibit sufficient decay characteristics to enable cavity excavation/use by wildlife. Priority snags have a diameter at breast height of > 51 cm (20 in) in western Washington and are > 2 m (6.5 ft) in height. Priority logs are > 30 cm (12 in) in diameter at the largest end, and > 6 m (20 ft) long.</p> <p style="text-align: right;">If wetland has 3 or more priority habitats = 4 points If wetland has 2 priority habitats = 3 points If wetland has 1 priority habitat = 1 point No habitats = 0 points</p> <p>Note: All vegetated wetlands are by definition a priority habitat but are not included in this list. Nearby wetlands are addressed in question H 2.4)</p>	1
	<p>H 2.4 <u>Wetland Landscape:</u> <i>Choose the one description of the landscape around the wetland that best fits (see p. 84)</i></p> <ul style="list-style-type: none"> • There are at least 3 other wetlands within 1/2 mile, and the connections between them are relatively undisturbed (light grazing between wetlands OK, as is lake shore with some boating, but connections should NOT be bisected by paved roads, fill, fields, or other development.... points = 5 <input type="checkbox"/> • The wetland is Lake-fringe on a lake with little disturbance and there are 3 other lake-fringe wetlands within 1/2 mile points = 5 <input type="checkbox"/> • There are at least 3 other wetlands within 1/2 mile, BUT the connections between them are disturbed. points = 3 <input checked="" type="checkbox"/> • The wetland fringe on a lake with disturbance and there are 3 other lake-fringe wetlands within 1/2 mile points = 3 <input type="checkbox"/> • There is at least 1 wetland within 1/2 mile points = 2 <input type="checkbox"/> • There are no wetlands within 1/2 mile..... points = 0 <input type="checkbox"/> 	3
	<p>H 2 TOTAL Score – opportunity for providing habitat <i>Add the scores from H2.1, H2.2, H2.3, H2.4</i></p>	5
	<p><i>TOTAL for H 1 from page 8</i></p>	8
◆	<p>Total Score for Habitat Functions <i>Add the points for H 1 and H 2; then record the result on p. 1</i></p>	13

Comments: _____

CATEGORIZATION BASED ON SPECIAL CHARACTERISTICS

Please determine if the wetland meets the attributes described below and circle the appropriate answers and Category.

Wetland Type – Check off any criteria that apply to the wetland. Circle the Category when the appropriate criteria are met.	
SC1	<p>Estuarine wetlands? (see p.86)</p> <p>Does the wetland unit meet the following criteria for Estuarine wetlands?</p> <p><input type="checkbox"/> The dominant water regime is tidal, <input type="checkbox"/> Vegetated, and <input type="checkbox"/> With a salinity greater than 0.5 ppt.</p> <p style="text-align: center;"><input type="checkbox"/> YES = Go to SC 1.1 <input checked="" type="checkbox"/> NO</p>
	<p>SC 1.1 Is the wetland unit within a National Wildlife Refuge, National Park, National Estuary Reserve, Natural Area Preserve, State Park or Educational, Environmental, or Scientific Reserve designated under WAC 332-30-151? <input type="checkbox"/> YES = Category I <input type="checkbox"/> NO = go to SC 1.2</p>
	<p>SC 1.2 Is the wetland at least 1 acre in size and meets at least two of the following conditions?</p> <p style="text-align: center;"><input type="checkbox"/> YES = Category I <input type="checkbox"/> NO = Category II</p> <p><input type="checkbox"/> The wetland is relatively undisturbed (has no diking, ditching, filling, cultivation, grazing, and has less than 10% cover of non-native plant species. If the non-native <i>Spartina</i> spp. are only species that cover more than 10% of the wetland, then the wetland should be given a dual rating (I/II). The area of <i>Spartina</i> would be rated a Category II while the relatively undisturbed upper marsh with native species would be a Category I. Do not, however, exclude the area of <i>Spartina</i> in determining the size threshold of 1 acre.</p> <p><input type="checkbox"/> At least 3/4 of the landward edge of the wetland has a 100 ft. buffer of shrub, forest, or un-grazed or un-mowed grassland</p> <p><input type="checkbox"/> The wetland has at least 2 of the following features: tidal channels, depressions with open water, or contiguous freshwater wetlands.</p>
SC2	<p>Natural Heritage Wetlands (see p. 87)</p> <p>Natural Heritage wetlands have been identified by the Washington Natural Heritage Program/DNR as either high quality undisturbed wetlands or wetlands that support state Threatened, Endangered, or Sensitive plant species.</p> <p>SC 2.1 Is the wetland being rated in a Section/Township/Range that contains a natural heritage wetland? (This question is used to screen out most sites before you need to contact WNHP/DNR.)</p> <p style="text-align: center;"><input type="checkbox"/> S/T/R information from Appendix D <input type="checkbox"/> or accessed from WNHP/DNR web site <input type="checkbox"/> YES Contact WNHP/DNR (see p. 79) and go to SC 2.2 <input checked="" type="checkbox"/> NO</p> <p>SC 2.2 Has DNR identified the wetland as a high quality undisturbed wetland or as a site with state threatened or endangered plant species?</p> <p style="text-align: center;"><input type="checkbox"/> YES = Category 1 <input checked="" type="checkbox"/> NO not a Heritage Wetland</p>
SC3	<p>Bogs (see p. 87)</p> <p>Does the wetland (or any part of the unit) meet both the criteria for soils and vegetation in bogs? Use the key below to identify if the wetland is a bog. If you answer yes you will still need to rate the wetland based on its function.</p> <ol style="list-style-type: none"> Does the unit have organic soil horizons (i.e. layers of organic soil), either peats or mucks, that compose 16 inches or more of the first 32 inches of soil profile? (See Appendix B for a field key to identify organic soils)? <input type="checkbox"/> YES = go to question 3 <input checked="" type="checkbox"/> NO = go to question 2 Does the wetland have organic soils, either peats or mucks that are less than 16 inches deep over bedrock, or an impermeable hardpan such as clay or volcanic ash, or that are floating on a lake or pond? <input type="checkbox"/> YES = go to question 3 <input checked="" type="checkbox"/> NO = is not a bog for purpose of rating Does the unit have more than 70% cover of mosses at ground level, AND other plants, if present, consist of the “bog” species listed in Table 3 as a significant component of the vegetation (more than 30% of the total shrub and herbaceous cover consists of species in Table 3)? <p style="text-align: center;"><input type="checkbox"/> YES = Is a bog for purpose of rating <input checked="" type="checkbox"/> NO = go to question 4</p> <p>NOTE: If you are uncertain about the extent of mosses in the understory you may substitute that criterion by measuring the pH of the water that seeps into a hole dug at least 16” deep. If the pH is less than 5.0 and the “bog” plant species in Table 3 are present, the wetland is a bog.</p> <ol style="list-style-type: none"> Is the unit forested (> 30% cover) with sitka spruce, subalpine fir, western red cedar, western hemlock, lodgepole pine, quaking aspen, Englemann’s spruce, or western white pine. WITH any of the species (or combination of species) on the bog species plant list in Table 3 as a significant component of the ground cover (> 30% coverage of the total shrub/herbaceous cover)? <p style="text-align: center;"><input type="checkbox"/> YES = Category I <input checked="" type="checkbox"/> NO = Is not a bog for purpose of rating</p>
	<p>Cat. I <input type="checkbox"/></p> <p>Cat. II <input type="checkbox"/></p> <p>Dual Rating I/II <input type="checkbox"/></p> <p>Cat I <input type="checkbox"/></p> <p>Cat. I <input type="checkbox"/></p>

SC4	<p>Forested Wetlands (see p. 90)</p> <p>Does the wetland have at least 1 acre of forest that meet one of these criteria for the Department of Fish and Wildlife’s forests as priority habitats? <i>If you answer yes you will still need to rate the wetland based on its function.</i></p> <p><input type="checkbox"/> Old-growth forests: (west of Cascade Crest) Stands of at least two three species forming a multi-layered canopy with occasional small openings; with at least 8 trees/acre (20 trees/hectare) that are at least 200 years of age OR have a diameter at breast height (dbh) of 32 inches (81 cm or more). NOTE: The criterion for dbh is based on measurements for upland forests. Two-hundred year old trees in wetlands will often have a smaller dbh because their growth rates are often slower. The DFW criterion is and “OR” so old-growth forests do not necessarily have to have trees of this diameter.</p> <p><input type="checkbox"/> Mature forests: (west of the Cascade Crest) Stands where the largest trees are 80 – 200 years old OR have an average diameters (dbh) exceeding 21 inches (53 cm); crown cover may be less than 100%; decay, decadence, numbers of snags, and quantity of large downed material is generally less than that found in old-growth.</p> <p><input type="checkbox"/> YES = Category I <input checked="" type="checkbox"/> NO = not a forested wetland with special characteristics</p>	<p>Cat. I <input type="checkbox"/></p>
SC5	<p>Wetlands in Coastal Lagoons (see p. 91)</p> <p>Does the wetland meet all of the following criteria of a wetland in a coastal lagoon?</p> <p><input type="checkbox"/> The wetland lies in a depression adjacent to marine waters that is wholly or partially separated from marine waters by sandbanks, gravel banks, shingle, or, less frequently, rocks.</p> <p><input type="checkbox"/> The lagoon in which the wetland is located contains surface water that is saline or brackish (> 0.5 ppt) during most of the year in at least a portion of the lagoon (<i>needs to be measured near the bottom.</i>)</p> <p><input type="checkbox"/> YES = Go to SC 5.1 <input checked="" type="checkbox"/> NO not a wetland in a coastal lagoon</p> <p>SC 5.1 Does the wetland meet all of the following three conditions?</p> <p><input type="checkbox"/> The wetland is relatively undisturbed (has no diking, ditching, filling, cultivation, grazing) and has less than 20% cover of invasive plant species (see list of invasive species on p. 74).</p> <p><input type="checkbox"/> At least 3/4 of the landward edge of the wetland has a 100 ft. buffer of shrub, forest, or un-grazed or un-mowed grassland.</p> <p><input type="checkbox"/> The wetland is larger than 1/10 acre (4350 square ft.)</p> <p><input type="checkbox"/> YES = Category I <input type="checkbox"/> NO = Category II</p>	<p style="background-color: #cccccc;">Cat. I <input type="checkbox"/></p> <p>Cat. II <input type="checkbox"/></p>
SC6	<p>Interdunal Wetlands (see p. 93)</p> <p>Is the wetland west of the 1889 line (also called the Western Boundary of Upland Ownership or WBUO)?</p> <p><input type="checkbox"/> YES = Go to SC 6.1 <input checked="" type="checkbox"/> NO not an interdunal wetland for rating</p> <p><i>If you answer yes you will still need to rate the wetland based on its functions.</i></p> <p>In practical terms that means the following geographic areas:</p> <ul style="list-style-type: none"> • Long Beach Peninsula -- lands west of SR 103 • Grayland-Westport -- lands west of SR 105 • Ocean Shores-Copalis – lands west of SR 115 and SR 109 <p>SC 6.1 Is the wetland one acre or larger, or is it in a mosaic of wetlands that is one acre or larger?</p> <p><input type="checkbox"/> YES = Category II <input type="checkbox"/> NO = go to SC 6.2</p> <p>SC 6.2 Is the wetland between 0.1 and 1 acre, or is it in a mosaic of wetlands that is between 0.1 and 1 acre?</p> <p><input type="checkbox"/> YES = Category III</p>	<p>Cat. II <input type="checkbox"/></p> <p>Cat. III <input type="checkbox"/></p>
◆	<p>Category of wetland based on Special Characteristics</p> <p><i>Choose the “highest” rating if wetland falls into several categories, and record on p. 1.</i></p> <p>If you answered NO for all types enter “Not Applicable” on p. 1</p>	<p>NA</p>

Comments:

WETLAND RATING FORM – WESTERN WASHINGTON
Version 2 – Updated July 2006 to increase accuracy and reproducibility among users
Updated Oct. 2008 with the new WDFW definitions for priority habitats

Name of wetland (if known): SR 520 East

Date of site visit: May 15, 2013

Rated by: C. Douglas & J. Pursley Trained by Ecology? Yes No

Date of training: May 2007

SEC: 28 TOWNSHP: 24N RNGE: 5E

Is S/T/R in Appendix D? Yes No

Map of wetland unit: Figure _____ Estimated size _____

SUMMARY OF RATING

Category based on FUNCTIONS provided by wetland: I II III IV

Category I =	Score > 70
Category II =	Score 51 - 69
Category III =	Score 30 – 50
Category IV =	Score < 30

Score for Water Quality Functions

10

Score for Hydrologic Functions

10

Score for Habitat Functions

13

TOTAL Score for Functions

33

Category based on SPECIAL CHARACTERISTICS of Wetland I II Does not apply

Final Category (choose the “highest” category from above”)

III

Summary of basic information about the wetland unit.

Wetland Unit has Special Characteristics		Wetland HGM Class used for Rating	
Estuarine	<input type="checkbox"/>	Depressional	<input type="checkbox"/>
Natural Heritage Wetland	<input type="checkbox"/>	Riverine	<input type="checkbox"/>
Bog	<input type="checkbox"/>	Lake-fringe	<input type="checkbox"/>
Mature Forest	<input type="checkbox"/>	Slope	<input checked="" type="checkbox"/>
Old Growth Forest	<input type="checkbox"/>	Flats	<input type="checkbox"/>
Coastal Lagoon	<input type="checkbox"/>	Freshwater Tidal	<input type="checkbox"/>
Interdunal	<input type="checkbox"/>		<input type="checkbox"/>
None of the above	<input checked="" type="checkbox"/>	Check if unit has multiple HGM classes present	<input type="checkbox"/>

Does the wetland being rated meet any of the criteria below? If you answer YES to any of the questions below you will need to protect the wetland according to the regulations regarding the special characteristics found in the wetland.

Check List for Wetlands that Need Additional Protection (in addition to the protection recommended for its category)	YES	NO
SP1. <i>Has the wetland unit been documented as a habitat for any Federally listed Threatened or Endangered animal or plant species (T/E species)?</i> For the purposes of this rating system, “documented” means the wetland is on the appropriate state or federal database.	<input type="checkbox"/>	<input checked="" type="checkbox"/>
SP2. <i>Has the wetland unit been documented as habitat for any State listed Threatened or Endangered animal species?</i> For the purposes of this rating system, “documented” means the wetland is on the appropriate state database. Note: Wetlands with State listed plant species are categorized as Category 1 Natural Heritage Wetlands (see p. 19 of data form).	<input type="checkbox"/>	<input checked="" type="checkbox"/>
SP3. <i>Does the wetland unit contain individuals of Priority species listed by the WDFW for the state?</i>	<input type="checkbox"/>	<input checked="" type="checkbox"/>
SP4. <i>Does the wetland unit have a local significance in addition to its functions?</i> For example, the wetland has been identified in the Shoreline Master Program, the Critical Areas Ordinance, or in a local management plan as having special significance.	<input type="checkbox"/>	<input checked="" type="checkbox"/>

To complete the next part of the data sheet you will need to determine the Hydrogeomorphic Class of the wetland being rated.

The hydrogeomorphic classification groups wetlands in to those that function in similar ways. This simplifies the questions needed to answer how well the wetland functions. The Hydrogeomorphic Class of a wetland can be determined using the key below. See p. 24 for more detailed instructions on classifying wetlands.

Classification of Vegetated Wetlands for Western Washington

If the hydrologic criteria listed in each question do not apply to the entire unit being rated, you probably have a unit with multiple HGM classes. In this case, identify which hydrologic criteria in questions 1-7 apply, and go to Question 8.

1. Are the water levels in the entire unit usually controlled by tides (i.e. except during floods)?
 NO – go to 2 YES – the wetland class is **Tidal Fringe**
 If yes, is the salinity of the water during periods of annual low flow below 0.5 ppt (parts per thousand)?
 YES – **Freshwater Tidal Fringe** NO – **Saltwater Tidal Fringe (Estuarine)**
*If your wetland can be classified as a Freshwater Tidal Fringe use the forms for **Riverine** wetlands. If it is a Saltwater Tidal Fringe it is rated as an **Estuarine** wetland. Wetlands that were call estuarine in the first and second editions of the rating system are called Salt Water Tidal Fringe in the Hydrogeomorphic Classification. Estuarine wetlands were categorized separately in the earlier editions, and this separation is being kept in this revision. To maintain consistency between editions, the term “Estuarine” wetland is kept. Please note, however, that the characteristics that define Category I and II estuarine wetlands have changed (see p. _____).*
-
2. The entire wetland unit is flat and precipitation is only source (>90%) of water to it. Groundwater and surface water runoff are NOT sources of water to the unit.
 NO – go to 3 YES – The wetland class is **Flats**
 If your wetland can be classified as a “Flats” wetland, use the form for **Depressional** wetlands.
-
3. Does the entire wetland meet both of the following criteria?
 The vegetated part of the wetland is on the shores of a body of permanent open water (without any vegetation on the surface) where at least 20 acres (8ha) in size;
 At least 30% of the open water area is deeper than 6.6 (2 m)?
 NO – go to 4 YES – The wetland class is **Lake-fringe (Lacustrine Fringe)**
-
4. Does the entire wetland meet all of the following criteria?
 The wetland is on a slope (*slope can be very gradual*).
 The water flows through the wetland in one direction (unidirectional) and usually comes from seeps. It may flow subsurface, as sheetflow, or in a swale without distinct banks.
 The water leaves the wetland **without being impounded**?
 NOTE: *Surface water does not pond in these types of wetlands except occasionally in very small and shallow depressions or behind hummocks (depressions are usually <3 ft diameter and less than 1 foot deep).*
 NO – go to 5 YES – The wetland class is **Slope**
-
5. Does the entire wetland meet all of the following criteria?
 The unit is in a valley or stream channel where it gets inundated by overbank flooding from that stream or river.
 The overbank flooding occurs at least once every two years.
 NOTE: *The riverine unit can contain depressions that are filled with water when the river is not flooding..*
 NO – go to 6 YES – The wetland class is **Riverine**
-
6. Is the entire wetland unit in a topographic depression in which water ponds, or is saturated to the surface, at some time of the year. This means that any outlet, if present is higher than the interior of the wetland.
 NO – go to 7 YES – The wetland class is **Depressional**
-
7. Is the entire wetland located in a very flat area with no obvious depression and no overbank flooding. The unit does not pond surface water more than a few inches. The unit seems to be maintained by high groundwater in the area. The wetland may be ditched, but has no obvious natural outlet.
 No – go to 8 YES – The wetland class is **Depressional**
-
8. Your wetland unit seems to be difficult to classify and probably contains several different HGM classes. For example, seeps at the base of a slope may grade into a riverine floodplain, or a small stream within a depressional wetland has a zone of flooding along its sides. GO BACK AND IDENTIFY WHICH OF THE HYDROLOGIC REGIMES DESCRIBED IN QUESTIONS 1-7 APPLY TO DIFFERENT AREAS IN THE UNIT (make a rough sketch to help you decide). Use the following table to identify the appropriate class to use for the rating system if you have several HGM classes present within your wetland. NOTE: Use this table only if the class that is recommended in the second column represents 10% or more of the total area of the wetland unit being rated. If the area of the class listed in column 2 is less than 10% of the unit, classify the wetland using the class that represents more than 90% of the total area.

HGM Classes within the wetland unit being rated	HGM Class to Use in Rating
Slope + Riverine	Riverine
Slope + Depressional	Depressional
Slope + Lake-fringe	Lake-fringe
Depressional + Riverine along stream within boundary	Depressional
Depressional + Lake-fringe	Depressional
Salt Water Tidal Fringe and any other class of freshwater wetland	Treat as ESTUARINE under wetlands with special characteristics

If you are unable still to determine which of the above criteria apply to your wetland, or you have more than 2 HGM classes within a wetland boundary, classify the wetland as **Depressional** for the rating.

S Slope Wetlands		Points
WATER QUALITY FUNCTIONS – Indicators that wetland functions to improve water quality.		(only 1 score per box) (see p.64)
S 1	Does the wetland have the <u>potential</u> to improve water quality?	
	S 1.1 Characteristics of average slope of unit: • Slope is 1% or less (a 1% slope has a 1 ft. vertical drop in elevation for every 100 ft. horizontal distance)..... points = 3 <input type="checkbox"/> • Slope is 1% - 2% points = 2 <input checked="" type="checkbox"/> • Slope is 2% - 5% points = 1 <input type="checkbox"/> • Slope is greater than 5% points = 0 <input type="checkbox"/>	2
	S 1.2 The soil 2 inches below the surface (or duff layer) is clay, organic (Use NRCS definitions). <input type="checkbox"/> YES = 3 points <input checked="" type="checkbox"/> NO = 0 points	0
	S 1.3 Characteristics of the vegetation in the wetland that trap sediments and pollutants: Choose the points appropriate for the description that best fits the vegetation in the wetland. Dense vegetation means you have trouble seeing the soil surface (>75% cover), and uncut means not grazed or mowed and plants are higher than 6 inches. • Dense, uncut, herbaceous vegetation > 90% of the wetland area..... points = 6 <input type="checkbox"/> • Dense, uncut, herbaceous vegetation > 1/2 of area points = 3 <input checked="" type="checkbox"/> • Dense, woody, vegetation > 1/2 of area..... points = 2 <input type="checkbox"/> • Dense, uncut, herbaceous vegetation > 1/4 of area points = 1 <input type="checkbox"/> • Does not meet any of the criteria above for vegetation..... points = 0 <input type="checkbox"/>	Figure <input type="checkbox"/> 3
Total for S 1		Add the points in the boxes above
		5
S 2	Does the wetland have the <u>opportunity</u> to improve water quality?	(see p. 67)
	Answer YES if you know or believe there are pollutants in groundwater or surface water coming into the wetland that would otherwise reduce water quality in streams, lakes or groundwater downgradient from the wetland? Note which of the following conditions provide the sources of pollutants. A unit may have pollutants coming from several sources, but any single source would qualify as opportunity. <input type="checkbox"/> Grazing in the wetland or within 150 ft <input checked="" type="checkbox"/> Untreated stormwater discharges to wetland <input checked="" type="checkbox"/> Tilled fields, logging, or orchards within 150 ft. of wetland <input type="checkbox"/> Residential, urban areas, or golf courses are within 150 ft. upslope of wetland <input type="checkbox"/> Other <input checked="" type="checkbox"/> YES multiplier is 2 <input type="checkbox"/> NO multiplier is 1	Multiplier 2
◆ TOTAL – Water Quality Functions		Multiply the score from S1 by S2; then add score to table on p. 1
		10
HYDROLOGIC FUNCTIONS – Indicators that wetland functions to reduce flooding and stream erosion.		
S 3	Does the wetland have the <u>potential</u> to reduce flooding and stream erosion?	(see p.68)
	S 3.1 Characteristics of vegetation that reduce the velocity of surface flows during storms: Choose the points appropriate for the description that best fits conditions in the wetland (stems of plants should be thick enough (usually > 1/8in), or dense enough to remain erect during surface flows). • Dense, uncut, rigid vegetation covers > 90% of the area of the wetland points = 6 <input type="checkbox"/> • Dense, uncut, rigid vegetation > 1/2 area of wetland..... points = 3 <input checked="" type="checkbox"/> • Dense, uncut, rigid vegetation > 1/4 area..... points = 1 <input type="checkbox"/> • More than 1/4 of area is grazed, mowed, tilled, or vegetation is not rigid points = 0 <input type="checkbox"/>	3
	S 3.2 Characteristics of slope wetland that holds back small amounts of flood flows. The slope has small surface depressions that can retain water over at least 10% of its area. <input checked="" type="checkbox"/> YES = 2 points <input type="checkbox"/> NO = 0 points	2
Total for S 3		Add the points in the boxes above
		5
S 4	Does the wetland have the <u>opportunity</u> to reduce flooding and erosion?	(see p. 70)
	Is the wetland in a landscape position where the reduction in water velocity it provides helps protect downstream property and aquatic resources from flooding or excessive and/or erosive flows? Note which of the following conditions apply. <input checked="" type="checkbox"/> Wetland has surface runoff that drains to a river or stream that has flooding problems <input type="checkbox"/> Other (Answer NO if the major source of water is controlled by a reservoir (e.g. wetland is a seep that is on the downstream side of a dam) <input checked="" type="checkbox"/> YES multiplier is 2 <input type="checkbox"/> NO multiplier is 1	Multiplier 2
◆ TOTAL – Hydrologic Functions		Multiply the score from S3 by S4; then add score to table on p. 1
		10

Comments: _____

These questions apply to wetlands of all HGM classes.		Points																
HABITAT FUNCTIONS – Indicators that wetland functions to provide important habitat.		(only 1 score per box)																
H 1	Does the wetland have the potential to provide habitat for many species?																	
H 1.1	<p>Vegetation structure (see P. 72): Check the types of vegetation classes present (as defined by Cowardin) – Size threshold for each class is 1/4 acre or more than 10% of the area if unit is smaller than 2.5 acres.</p> <p><input type="checkbox"/> Aquatic Bed <input checked="" type="checkbox"/> Emergent plants <input checked="" type="checkbox"/> Scrub/shrub (areas where shrubs have > 30% cover) <input checked="" type="checkbox"/> Forested (areas where trees have > 30% cover)</p> <p>If the unit has a forested class check if: <input type="checkbox"/> The forested class has 3 out of 5 strata (canopy, sub-canopy, shrubs, herbaceous, moss/ground-cover) that each cover 20% within the forested polygon.</p> <p>Add the number of vegetation types that qualify. If you have:</p> <table style="width: 100%; border: none;"> <tr> <td style="width: 50%;">4 structures or more..... points = 4</td> <td style="width: 50%; text-align: right;">Map of Cowardin vegetation classes</td> </tr> <tr> <td>2 structures..... points = 1</td> <td style="text-align: right;">3 structures..... points = 2</td> </tr> <tr> <td></td> <td style="text-align: right;">1 structure..... points = 0</td> </tr> </table>	4 structures or more..... points = 4	Map of Cowardin vegetation classes	2 structures..... points = 1	3 structures..... points = 2		1 structure..... points = 0	<p>Figure <input type="checkbox"/></p> <p style="text-align: right;">2</p>										
4 structures or more..... points = 4	Map of Cowardin vegetation classes																	
2 structures..... points = 1	3 structures..... points = 2																	
	1 structure..... points = 0																	
H 1.2	<p>Hydroperiods (see p.73): Check the types of water regimes (hydroperiods) present within the wetland. The water regime has to cover more than 10% of the wetland or 1/4 acre to count (see text for descriptions of hydroperiods).</p> <table style="width: 100%; border: none;"> <tr> <td style="width: 50%;"><input type="checkbox"/> Permanently flooded or inundated</td> <td style="width: 50%;">4 or more types present</td> <td style="width: 50%;">points = 3</td> <td style="width: 50%;"><input type="checkbox"/></td> </tr> <tr> <td><input checked="" type="checkbox"/> Seasonally flooded or inundated</td> <td>3 or more types present</td> <td>points = 2</td> <td><input type="checkbox"/></td> </tr> <tr> <td><input checked="" type="checkbox"/> Occasionally flooded or inundated</td> <td>2 types present</td> <td>points = 1</td> <td><input checked="" type="checkbox"/></td> </tr> <tr> <td><input checked="" type="checkbox"/> Saturated only</td> <td>1 type present</td> <td>points = 0</td> <td><input type="checkbox"/></td> </tr> </table> <p><input type="checkbox"/> Permanently flowing stream or river in, or adjacent to, the wetland <input type="checkbox"/> Seasonally flowing stream in, or adjacent to, the wetland</p> <p><input type="checkbox"/> Lake-fringe wetland..... = 2 points <input type="checkbox"/> Freshwater tidal wetland..... = 2 points</p> <p style="text-align: right;">Map of hydroperiods</p>	<input type="checkbox"/> Permanently flooded or inundated	4 or more types present	points = 3	<input type="checkbox"/>	<input checked="" type="checkbox"/> Seasonally flooded or inundated	3 or more types present	points = 2	<input type="checkbox"/>	<input checked="" type="checkbox"/> Occasionally flooded or inundated	2 types present	points = 1	<input checked="" type="checkbox"/>	<input checked="" type="checkbox"/> Saturated only	1 type present	points = 0	<input type="checkbox"/>	<p>Figure <input type="checkbox"/></p> <p style="text-align: right;">1</p>
<input type="checkbox"/> Permanently flooded or inundated	4 or more types present	points = 3	<input type="checkbox"/>															
<input checked="" type="checkbox"/> Seasonally flooded or inundated	3 or more types present	points = 2	<input type="checkbox"/>															
<input checked="" type="checkbox"/> Occasionally flooded or inundated	2 types present	points = 1	<input checked="" type="checkbox"/>															
<input checked="" type="checkbox"/> Saturated only	1 type present	points = 0	<input type="checkbox"/>															
H 1.3	<p>Richness of Plant Species (see p. 75): Count the number of plant species in the wetland that cover at least 10 ft² (different patches of the same species can be combined to meet the size threshold) You do not have to name the species. Do not include Eurasian Milfoil, reed canarygrass, purple loosestrife, Canadian Thistle.</p> <p>If you counted:</p> <table style="width: 100%; border: none;"> <tr> <td style="width: 50%;">> 19 species..... points = 2</td> <td style="width: 50%;"><input type="checkbox"/></td> </tr> <tr> <td>5 – 19 species..... points = 1</td> <td><input checked="" type="checkbox"/></td> </tr> <tr> <td>< 5 species..... points = 0</td> <td><input type="checkbox"/></td> </tr> </table> <p>List species below if you want to:</p>	> 19 species..... points = 2	<input type="checkbox"/>	5 – 19 species..... points = 1	<input checked="" type="checkbox"/>	< 5 species..... points = 0	<input type="checkbox"/>	<p style="text-align: right;">1</p>										
> 19 species..... points = 2	<input type="checkbox"/>																	
5 – 19 species..... points = 1	<input checked="" type="checkbox"/>																	
< 5 species..... points = 0	<input type="checkbox"/>																	
H 1.4	<p>Interspersion of Habitats (see p. 76): Decided from the diagrams below whether interspersion between Cowardin vegetation (described in H1.1), or the classes and unvegetated areas (can include open water or mudflats) is high, medium, low, or none.</p> <div style="text-align: center;"> <p>None = 0 points Low = 1 point Moderate = 2 points</p> <p>High = 3 points [riparian braided channels]</p> </div> <p>Note: If you have 4 or more classes or 3 vegetation classes and open water, the rating is always “high”.</p> <p style="text-align: right;">Use map of Cowardin classes.</p>	<p>Figure <input type="checkbox"/></p> <p style="text-align: right;">3</p>																
H 1.5	<p>Special Habitat Features (see p. 77): Check the habitat features that are present in the wetland. The number of checks is the number of points you put into the next column.</p> <p><input checked="" type="checkbox"/> Large, downed, woody debris within the wetland (> 4 in. diameter and 6 ft. long) <input checked="" type="checkbox"/> Standing snags (diameter at the bottom > 4 inches) in the wetland <input type="checkbox"/> Undercut banks are present for at least 6.6 ft. (2m) and/or overhanging vegetation extends at least 3.3 ft. (1m) over a stream (or ditch) in, or contiguous with the unit, for at least 33 ft. (10m) <input type="checkbox"/> Stable steep banks of fine material that might be used by beaver or muskrat for denning (> 30 degree slope) OR signs of recent beaver activity are present (cut shrubs or trees that have not yet turned grey/brown) <input type="checkbox"/> At least 1/4 acre of thin-stemmed persistent vegetation or woody branches are present in areas that are permanently or seasonally inundated (structures for egg-laying by amphibians) <input type="checkbox"/> Invasive plants cover less than 25% of the wetland area in each stratum of plants</p> <p>NOTE: The 20% stated in early printings of the manual on page 78 is an error.</p>	<p style="text-align: right;">2</p>																
H 1 TOTAL Score – potential for providing habitat		Add the points in the column above																
		9																

H 2	Does the wetland have the <u>opportunity</u> to provide habitat for many species?	(only 1 score per box)
	<p>H 2.1 <u>Buffers</u> (see P. 80): Choose the description that best represents condition of buffer of wetland unit. The highest scoring criterion that applies to the wetland is to be used in the rating. See text for definition of "undisturbed".</p> <p><input type="checkbox"/> 100m (330 ft) of relatively undisturbed vegetated areas, rocky areas, or open water > 95% of circumference. No structures are within the undisturbed part of buffer (relatively undisturbed also means no grazing, no landscaping, no daily human use)..... points = 5</p> <p><input type="checkbox"/> 100m (330 ft) of relatively undisturbed vegetated areas, rocky areas, or open water > 50% circumference points = 4</p> <p><input type="checkbox"/> 50m (170 ft) of relatively undisturbed vegetated areas, rocky areas, or open water > 95% circumference points = 4</p> <p><input type="checkbox"/> 100m (330 ft) of relatively undisturbed vegetated areas, rocky areas, or open water > 25% circumference points = 3</p> <p><input type="checkbox"/> 50m (170 ft) of relatively undisturbed vegetated areas, rocky areas, or open water for > 50% circumference points = 3</p> <p>If buffer does not meet any of the criteria above:</p> <p><input type="checkbox"/> No paved areas (except paved trails) or buildings within 25m (80 ft) of wetland > 95% circumference. Light to moderate grazing or lawns are OK points = 2</p> <p><input type="checkbox"/> No paved areas of buildings within 50m of wetland for > 50% circumference. Light to moderate grazing or lawns are OK points = 2</p> <p><input type="checkbox"/> Heavy grazing in buffer points = 1</p> <p><input type="checkbox"/> Vegetated buffers are < 2m wide (6.6 ft) for more than 95% circumference (e.g. tilled fields, paving, basalt bedrock extend to edge of wetland) points = 0</p> <p><input checked="" type="checkbox"/> Buffer does not meet any of the criteria above points = 1</p> <p style="text-align: right;">Arial photo showing buffers</p>	<p>Figure <input type="checkbox"/></p> <p style="text-align: right;">1</p>
	<p>H 2.2 <u>Corridors and Connections</u> (see p. 81)</p> <p>H 2.2.1 Is the wetland part of a relatively undisturbed and unbroken vegetated corridor (either riparian or upland) that is at least 150 ft. wide, has at least a 30% cover of shrubs, forest or native undisturbed prairie, that connects to estuaries, other wetlands or undisturbed uplands that are at least 250 acres in size? (<i>Dams in riparian corridors, heavily used gravel roads, paved roads, are considered breaks in the corridor.</i>)</p> <p style="text-align: center;"><input type="checkbox"/> YES = 4 points (go to H 2.3) <input checked="" type="checkbox"/> NO = go to H 2.2.2</p> <p>H. 2.2.2 Is the wetland part of a relatively undisturbed and unbroken vegetated corridor (either riparian or upland) that is at least 50 ft. wide, has at least 30% cover of shrubs or forest, and connects to estuaries, other wetlands or undisturbed uplands that are at least 25 acres in size? OR a Lake-fringe wetland, if it does not have an undisturbed corridor as in the question above?</p> <p style="text-align: center;"><input type="checkbox"/> YES = 2 points (go to H 2.3) <input checked="" type="checkbox"/> NO = go to H 2.2.3</p> <p>H. 2.2.3 Is the wetland:</p> <ul style="list-style-type: none"> • Within 5 mi (8km) of a brackish or salt water estuary OR • Within 3 miles of a large field or pasture (> 40 acres) OR • Within 1 mile of a lake greater than 20 acres? <p style="text-align: right;"><input type="checkbox"/> YES = 1 point <input checked="" type="checkbox"/> NO = 0 points</p>	<p style="text-align: right;">0</p>

Comments: _____

	<p>H 2.3 <u>Near or adjacent to other priority habitats listed by WDFW</u> (see p. 82): (see new and complete descriptions of WDFW priority habitats, and the counties in which they can be found, in the PHS report http://wdfw.wa.gov/hab/phslist.htm)</p> <p>Which of the following priority habitats are within 330 ft. (100m) of the wetland unit? NOTE: the connections do not have to be relatively undisturbed.</p> <p><input type="checkbox"/> Aspen Stands: Pure or mixed stands of aspen greater than 0.4 ha (1 acre).</p> <p><input type="checkbox"/> Biodiversity Areas and Corridors: Areas of habitat that are relatively important to various species of native fish and wildlife (full descriptions in WDFW PHS report p. 152).</p> <p><input type="checkbox"/> Herbaceous Balds: Variable size patches of grass and forbs on shallow soils over bedrock.</p> <p><input type="checkbox"/> Old-growth/Mature forests: (Old-growth west of Cascade crest) Stands of at least 2 tree species, forming a multi-layered canopy with occasional small openings; with at least 20 trees/ha (8 trees/acre) > 81 cm (32 in) dbh or > 200 years of age. (Mature forests) Stands with average diameters exceeding 53 cm (21 in) dbh; crown cover may be less than 100%; decay, decadence, numbers of snags, and quantity of large downed material is generally less than that found in old-growth; 80 - 200 years old west of the Cascade crest.</p> <p><input type="checkbox"/> Oregon white Oak: Woodlands Stands of pure oak or oak/conifer associations where canopy coverage of the oak component is important (full descriptions in WDFW PHS report p. 158).</p> <p><input type="checkbox"/> Riparian: The area adjacent to aquatic systems with flowing water that contains elements of both aquatic and terrestrial ecosystems which mutually influence each other.</p> <p><input type="checkbox"/> Westside Prairies: Herbaceous, non-forested plant communities that can either take the form of a dry prairie or a wet prairie (full descriptions in WDFW PHS report p. 161).</p> <p><input type="checkbox"/> Instream: The combination of physical, biological, and chemical processes and conditions that interact to provide functional life history requirements for instream fish and wildlife resources.</p> <p><input type="checkbox"/> Nearshore: Relatively undisturbed nearshore habitats. These include Coastal Nearshore, Open Coast Nearshore, and Puget Sound Nearshore. (full descriptions of habitats and the definition of relatively undisturbed are in WDFW report: pp. 167-169 and glossary in Appendix A).</p> <p><input type="checkbox"/> Caves: A naturally occurring cavity, recess, void, or system of interconnected passages under the earth in soils, rock, ice, or other geological formations and is large enough to contain a human.</p> <p><input type="checkbox"/> Cliffs: Greater than 7.6 m (25 ft) high and occurring below 5000 ft.</p> <p><input type="checkbox"/> Talus: Homogenous areas of rock rubble ranging in average size 0.15 - 2.0 m (0.5 - 6.5 ft), composed of basalt, andesite, and/or sedimentary rock, including riprap slides and mine tailings. May be associated with cliffs.</p> <p><input type="checkbox"/> Snags and Logs: Trees are considered snags if they are dead or dying and exhibit sufficient decay characteristics to enable cavity excavation/use by wildlife. Priority snags have a diameter at breast height of > 51 cm (20 in) in western Washington and are > 2 m (6.5 ft) in height. Priority logs are > 30 cm (12 in) in diameter at the largest end, and > 6 m (20 ft) long.</p> <p style="text-align: right;">If wetland has 3 or more priority habitats = 4 points If wetland has 2 priority habitats = 3 points If wetland has 1 priority habitat = 1 point No habitats = 0 points</p> <p>Note: All vegetated wetlands are by definition a priority habitat but are not included in this list. Nearby wetlands are addressed in question H 2.4)</p>	0
	<p>H 2.4 <u>Wetland Landscape:</u> Choose the one description of the landscape around the wetland that best fits (see p. 84)</p> <ul style="list-style-type: none"> • There are at least 3 other wetlands within 1/2 mile, and the connections between them are relatively undisturbed (light grazing between wetlands OK, as is lake shore with some boating, but connections should NOT be bisected by paved roads, fill, fields, or other development.... points = 5 <input type="checkbox"/> • The wetland is Lake-fringe on a lake with little disturbance and there are 3 other lake-fringe wetlands within 1/2 mile points = 5 <input type="checkbox"/> • There are at least 3 other wetlands within 1/2 mile, BUT the connections between them are disturbed. points = 3 <input checked="" type="checkbox"/> • The wetland fringe on a lake with disturbance and there are 3 other lake-fringe wetlands within 1/2 mile points = 3 <input type="checkbox"/> • There is at least 1 wetland within 1/2 mile points = 2 <input type="checkbox"/> • There are no wetlands within 1/2 mile..... points = 0 <input type="checkbox"/> 	3
	<p>H 2 TOTAL Score – opportunity for providing habitat Add the scores from H2.1, H2.2, H2.3, H2.4</p>	4
	<p>TOTAL for H 1 from page 8</p>	9
◆	<p>Total Score for Habitat Functions Add the points for H 1 and H 2; then record the result on p. 1</p>	13

Comments: _____

CATEGORIZATION BASED ON SPECIAL CHARACTERISTICS

Please determine if the wetland meets the attributes described below and circle the appropriate answers and Category.

Wetland Type – Check off any criteria that apply to the wetland. Circle the Category when the appropriate criteria are met.	
SC1	<p>Estuarine wetlands? (see p.86)</p> <p>Does the wetland unit meet the following criteria for Estuarine wetlands?</p> <p><input type="checkbox"/> The dominant water regime is tidal, <input type="checkbox"/> Vegetated, and <input type="checkbox"/> With a salinity greater than 0.5 ppt.</p> <p style="text-align: center;"><input type="checkbox"/> YES = Go to SC 1.1 <input checked="" type="checkbox"/> NO</p>
	<p>SC 1.1 Is the wetland unit within a National Wildlife Refuge, National Park, National Estuary Reserve, Natural Area Preserve, State Park or Educational, Environmental, or Scientific Reserve designated under WAC 332-30-151? <input type="checkbox"/> YES = Category I <input type="checkbox"/> NO = go to SC 1.2</p>
	<p>SC 1.2 Is the wetland at least 1 acre in size and meets at least two of the following conditions?</p> <p style="text-align: center;"><input type="checkbox"/> YES = Category I <input type="checkbox"/> NO = Category II</p> <p><input type="checkbox"/> The wetland is relatively undisturbed (has no diking, ditching, filling, cultivation, grazing, and has less than 10% cover of non-native plant species. If the non-native <i>Spartina</i> spp. are only species that cover more than 10% of the wetland, then the wetland should be given a dual rating (I/II). The area of <i>Spartina</i> would be rated a Category II while the relatively undisturbed upper marsh with native species would be a Category I. Do not, however, exclude the area of <i>Spartina</i> in determining the size threshold of 1 acre.</p> <p><input type="checkbox"/> At least 3/4 of the landward edge of the wetland has a 100 ft. buffer of shrub, forest, or un-grazed or un-mowed grassland</p> <p><input type="checkbox"/> The wetland has at least 2 of the following features: tidal channels, depressions with open water, or contiguous freshwater wetlands.</p>
SC2	<p>Natural Heritage Wetlands (see p. 87)</p> <p>Natural Heritage wetlands have been identified by the Washington Natural Heritage Program/DNR as either high quality undisturbed wetlands or wetlands that support state Threatened, Endangered, or Sensitive plant species.</p> <p>SC 2.1 Is the wetland being rated in a Section/Township/Range that contains a natural heritage wetland? (This question is used to screen out most sites before you need to contact WNHP/DNR.)</p> <p style="text-align: center;"><input type="checkbox"/> S/T/R information from Appendix D <input type="checkbox"/> or accessed from WNHP/DNR web site <input type="checkbox"/> YES Contact WNHP/DNR (see p. 79) and go to SC 2.2 <input checked="" type="checkbox"/> NO</p> <p>SC 2.2 Has DNR identified the wetland as a high quality undisturbed wetland or as a site with state threatened or endangered plant species?</p> <p style="text-align: center;"><input type="checkbox"/> YES = Category 1 <input checked="" type="checkbox"/> NO not a Heritage Wetland</p>
SC3	<p>Bogs (see p. 87)</p> <p>Does the wetland (or any part of the unit) meet both the criteria for soils and vegetation in bogs? Use the key below to identify if the wetland is a bog. If you answer yes you will still need to rate the wetland based on its function.</p> <ol style="list-style-type: none"> Does the unit have organic soil horizons (i.e. layers of organic soil), either peats or mucks, that compose 16 inches or more of the first 32 inches of soil profile? (See Appendix B for a field key to identify organic soils)? <input type="checkbox"/> YES = go to question 3 <input checked="" type="checkbox"/> NO = go to question 2 Does the wetland have organic soils, either peats or mucks that are less than 16 inches deep over bedrock, or an impermeable hardpan such as clay or volcanic ash, or that are floating on a lake or pond? <input type="checkbox"/> YES = go to question 3 <input checked="" type="checkbox"/> NO = is not a bog for purpose of rating Does the unit have more than 70% cover of mosses at ground level, AND other plants, if present, consist of the “bog” species listed in Table 3 as a significant component of the vegetation (more than 30% of the total shrub and herbaceous cover consists of species in Table 3)? <p style="text-align: center;"><input type="checkbox"/> YES = Is a bog for purpose of rating <input checked="" type="checkbox"/> NO = go to question 4</p> <p>NOTE: If you are uncertain about the extent of mosses in the understory you may substitute that criterion by measuring the pH of the water that seeps into a hole dug at least 16” deep. If the pH is less than 5.0 and the “bog” plant species in Table 3 are present, the wetland is a bog.</p> <ol style="list-style-type: none"> Is the unit forested (> 30% cover) with sitka spruce, subalpine fir, western red cedar, western hemlock, lodgepole pine, quaking aspen, Englemann’s spruce, or western white pine. WITH any of the species (or combination of species) on the bog species plant list in Table 3 as a significant component of the ground cover (> 30% coverage of the total shrub/herbaceous cover)? <p style="text-align: center;"><input type="checkbox"/> YES = Category I <input checked="" type="checkbox"/> NO = Is not a bog for purpose of rating</p>
	<p>Cat. I <input type="checkbox"/></p> <p>Cat. II <input type="checkbox"/></p> <p>Dual Rating I/II <input type="checkbox"/></p> <p>Cat I <input type="checkbox"/></p> <p>Cat. I <input type="checkbox"/></p>

SC4	<p>Forested Wetlands (see p. 90)</p> <p>Does the wetland have at least 1 acre of forest that meet one of these criteria for the Department of Fish and Wildlife’s forests as priority habitats? <i>If you answer yes you will still need to rate the wetland based on its function.</i></p> <p><input type="checkbox"/> Old-growth forests: (west of Cascade Crest) Stands of at least two three species forming a multi-layered canopy with occasional small openings; with at least 8 trees/acre (20 trees/hectare) that are at least 200 years of age OR have a diameter at breast height (dbh) of 32 inches (81 cm or more). NOTE: The criterion for dbh is based on measurements for upland forests. Two-hundred year old trees in wetlands will often have a smaller dbh because their growth rates are often slower. The DFW criterion is and “OR” so old-growth forests do not necessarily have to have trees of this diameter.</p> <p><input type="checkbox"/> Mature forests: (west of the Cascade Crest) Stands where the largest trees are 80 – 200 years old OR have an average diameters (dbh) exceeding 21 inches (53 cm); crown cover may be less than 100%; decay, decadence, numbers of snags, and quantity of large downed material is generally less than that found in old-growth.</p> <p><input type="checkbox"/> YES = Category I <input checked="" type="checkbox"/> NO = not a forested wetland with special characteristics</p>	<p>Cat. I <input type="checkbox"/></p>
SC5	<p>Wetlands in Coastal Lagoons (see p. 91)</p> <p>Does the wetland meet all of the following criteria of a wetland in a coastal lagoon?</p> <p><input type="checkbox"/> The wetland lies in a depression adjacent to marine waters that is wholly or partially separated from marine waters by sandbanks, gravel banks, shingle, or, less frequently, rocks.</p> <p><input type="checkbox"/> The lagoon in which the wetland is located contains surface water that is saline or brackish (> 0.5 ppt) during most of the year in at least a portion of the lagoon (<i>needs to be measured near the bottom.</i>)</p> <p><input type="checkbox"/> YES = Go to SC 5.1 <input checked="" type="checkbox"/> NO not a wetland in a coastal lagoon</p> <p>SC 5.1 Does the wetland meet all of the following three conditions?</p> <p><input type="checkbox"/> The wetland is relatively undisturbed (has no diking, ditching, filling, cultivation, grazing) and has less than 20% cover of invasive plant species (see list of invasive species on p. 74).</p> <p><input type="checkbox"/> At least 3/4 of the landward edge of the wetland has a 100 ft. buffer of shrub, forest, or un-grazed or un-mowed grassland.</p> <p><input type="checkbox"/> The wetland is larger than 1/10 acre (4350 square ft.)</p> <p><input type="checkbox"/> YES = Category I <input type="checkbox"/> NO = Category II</p>	<p>Cat. I <input type="checkbox"/></p> <p>Cat. II <input type="checkbox"/></p>
SC6	<p>Interdunal Wetlands (see p. 93)</p> <p>Is the wetland west of the 1889 line (also called the Western Boundary of Upland Ownership or WBUO)?</p> <p><input type="checkbox"/> YES = Go to SC 6.1 <input checked="" type="checkbox"/> NO not an interdunal wetland for rating</p> <p><i>If you answer yes you will still need to rate the wetland based on its functions.</i></p> <p>In practical terms that means the following geographic areas:</p> <ul style="list-style-type: none"> • Long Beach Peninsula -- lands west of SR 103 • Grayland-Westport -- lands west of SR 105 • Ocean Shores-Copalis – lands west of SR 115 and SR 109 <p>SC 6.1 Is the wetland one acre or larger, or is it in a mosaic of wetlands that is one acre or larger?</p> <p><input type="checkbox"/> YES = Category II <input type="checkbox"/> NO = go to SC 6.2</p> <p>SC 6.2 Is the wetland between 0.1 and 1 acre, or is it in a mosaic of wetlands that is between 0.1 and 1 acre?</p> <p><input type="checkbox"/> YES = Category III</p>	<p>Cat. II <input type="checkbox"/></p> <p>Cat. III <input type="checkbox"/></p>
◆	<p>Category of wetland based on Special Characteristics</p> <p>Choose the “highest” rating if wetland falls into several categories, and record on p. 1. If you answered NO for all types enter “Not Applicable” on p. 1</p>	<p>NA</p>

Comments:

WETLAND RATING FORM – WESTERN WASHINGTON
Version 2 – Updated July 2006 to increase accuracy and reproducibility among users
Updated Oct. 2008 with the new WDFW definitions for priority habitats

Name of wetland (if known): SR 520 West

Date of site visit: February 28, 2013

Rated by: C. Douglas & J. Pursley Trained by Ecology? Yes No

Date of training: May 2007

SEC: 28 TOWNSHP: 24N RNGE: 5E

Is S/T/R in Appendix D? Yes No

Map of wetland unit: Figure _____ Estimated size _____

SUMMARY OF RATING

Category based on FUNCTIONS provided by wetland: I II III IV

Category I =	Score > 70
Category II =	Score 51 - 69
Category III =	Score 30 – 50
Category IV =	Score < 30

Score for Water Quality Functions	18
Score for Hydrologic Functions	16
Score for Habitat Functions	14
TOTAL Score for Functions	48

Category based on SPECIAL CHARACTERISTICS of Wetland I II Does not apply

Final Category (choose the “highest” category from above”)

III

Summary of basic information about the wetland unit.

Wetland Unit has Special Characteristics		Wetland HGM Class used for Rating	
Estuarine	<input type="checkbox"/>	Depressional	<input checked="" type="checkbox"/>
Natural Heritage Wetland	<input type="checkbox"/>	Riverine	<input type="checkbox"/>
Bog	<input type="checkbox"/>	Lake-fringe	<input type="checkbox"/>
Mature Forest	<input type="checkbox"/>	Slope	<input checked="" type="checkbox"/>
Old Growth Forest	<input type="checkbox"/>	Flats	<input type="checkbox"/>
Coastal Lagoon	<input type="checkbox"/>	Freshwater Tidal	<input type="checkbox"/>
Interdunal	<input type="checkbox"/>		<input type="checkbox"/>
None of the above	<input checked="" type="checkbox"/>	Check if unit has multiple HGM classes present	<input type="checkbox"/>

Does the wetland being rated meet any of the criteria below? If you answer YES to any of the questions below you will need to protect the wetland according to the regulations regarding the special characteristics found in the wetland.

Check List for Wetlands that Need Additional Protection (in addition to the protection recommended for its category)	YES	NO
SP1. <i>Has the wetland unit been documented as a habitat for any Federally listed Threatened or Endangered animal or plant species (T/E species)?</i> For the purposes of this rating system, “documented” means the wetland is on the appropriate state or federal database.	<input type="checkbox"/>	<input checked="" type="checkbox"/>
SP2. <i>Has the wetland unit been documented as habitat for any State listed Threatened or Endangered animal species?</i> For the purposes of this rating system, “documented” means the wetland is on the appropriate state database. Note: Wetlands with State listed plant species are categorized as Category 1 Natural Heritage Wetlands (see p. 19 of data form).	<input type="checkbox"/>	<input checked="" type="checkbox"/>
SP3. <i>Does the wetland unit contain individuals of Priority species listed by the WDFW for the state?</i>	<input type="checkbox"/>	<input checked="" type="checkbox"/>
SP4. <i>Does the wetland unit have a local significance in addition to its functions?</i> For example, the wetland has been identified in the Shoreline Master Program, the Critical Areas Ordinance, or in a local management plan as having special significance.	<input type="checkbox"/>	<input checked="" type="checkbox"/>

To complete the next part of the data sheet you will need to determine the Hydrogeomorphic Class of the wetland being rated.

The hydrogeomorphic classification groups wetlands in to those that function in similar ways. This simplifies the questions needed to answer how well the wetland functions. The Hydrogeomorphic Class of a wetland can be determined using the key below. See p. 24 for more detailed instructions on classifying wetlands.

Classification of Vegetated Wetlands for Western Washington

If the hydrologic criteria listed in each question do not apply to the entire unit being rated, you probably have a unit with multiple HGM classes. In this case, identify which hydrologic criteria in questions 1-7 apply, and go to Question 8.

1. Are the water levels in the entire unit usually controlled by tides (i.e. except during floods)?
 NO – go to 2 YES – the wetland class is **Tidal Fringe**
 If yes, is the salinity of the water during periods of annual low flow below 0.5 ppt (parts per thousand)?
 YES – **Freshwater Tidal Fringe** NO – **Saltwater Tidal Fringe (Estuarine)**
*If your wetland can be classified as a Freshwater Tidal Fringe use the forms for **Riverine** wetlands. If it is a Saltwater Tidal Fringe it is rated as an **Estuarine** wetland. Wetlands that were call estuarine in the first and second editions of the rating system are called Salt Water Tidal Fringe in the Hydrogeomorphic Classification. Estuarine wetlands were categorized separately in the earlier editions, and this separation is being kept in this revision. To maintain consistency between editions, the term “Estuarine” wetland is kept. Please note, however, that the characteristics that define Category I and II estuarine wetlands have changed (see p. _____).*
-
2. The entire wetland unit is flat and precipitation is only source (>90%) of water to it. Groundwater and surface water runoff are NOT sources of water to the unit.
 NO – go to 3 YES – The wetland class is **Flats**
 If your wetland can be classified as a “Flats” wetland, use the form for **Depressional** wetlands.
-
3. Does the entire wetland meet both of the following criteria?
 The vegetated part of the wetland is on the shores of a body of permanent open water (without any vegetation on the surface) where at least 20 acres (8ha) in size;
 At least 30% of the open water area is deeper than 6.6 (2 m)?
 NO – go to 4 YES – The wetland class is **Lake-fringe (Lacustrine Fringe)**
-
4. Does the entire wetland meet all of the following criteria?
 The wetland is on a slope (*slope can be very gradual*).
 The water flows through the wetland in one direction (unidirectional) and usually comes from seeps. It may flow subsurface, as sheetflow, or in a swale without distinct banks.
 The water leaves the wetland **without being impounded?**
 NOTE: *Surface water does not pond in these types of wetlands except occasionally in very small and shallow depressions or behind hummocks (depressions are usually <3 ft diameter and less than 1 foot deep).*
 NO – go to 5 YES – The wetland class is **Slope**
-
5. Does the entire wetland meet all of the following criteria?
 The unit is in a valley or stream channel where it gets inundated by overbank flooding from that stream or river.
 The overbank flooding occurs at least once every two years.
 NOTE: *The riverine unit can contain depressions that are filled with water when the river is not flooding..*
 NO – go to 6 YES – The wetland class is **Riverine**
-
6. Is the entire wetland unit in a topographic depression in which water ponds, or is saturated to the surface, at some time of the year. This means that any outlet, if present is higher than the interior of the wetland.
 NO – go to 7 YES – The wetland class is **Depressional**
-
7. Is the entire wetland located in a very flat area with no obvious depression and no overbank flooding. The unit does not pond surface water more than a few inches. The unit seems to be maintained by high groundwater in the area. The wetland may be ditched, but has no obvious natural outlet.
 No – go to 8 YES – The wetland class is **Depressional**
-
8. Your wetland unit seems to be difficult to classify and probably contains several different HGM classes. For example, seeps at the base of a slope may grade into a riverine floodplain, or a small stream within a depressional wetland has a zone of flooding along its sides. GO BACK AND IDENTIFY WHICH OF THE HYDROLOGIC REGIMES DESCRIBED IN QUESTIONS 1-7 APPLY TO DIFFERENT AREAS IN THE UNIT (make a rough sketch to help you decide). Use the following table to identify the appropriate class to use for the rating system if you have several HGM classes present within your wetland. NOTE: Use this table only if the class that is recommended in the second column represents 10% or more of the total area of the wetland unit being rated. If the area of the class listed in column 2 is less than 10% of the unit, classify the wetland using the class that represents more than 90% of the total area.

HGM Classes within the wetland unit being rated	HGM Class to Use in Rating
Slope + Riverine	Riverine
Slope + Depressional	Depressional
Slope + Lake-fringe	Lake-fringe
Depressional + Riverine along stream within boundary	Depressional
Depressional + Lake-fringe	Depressional
Salt Water Tidal Fringe and any other class of freshwater wetland	Treat as ESTUARINE under wetlands with special characteristics

If you are unable still to determine which of the above criteria apply to your wetland, or you have more than 2 HGM classes within a wetland boundary, classify the wetland as **Depressional** for the rating.

D Depressional and Flat Wetlands		Points
WATER QUALITY FUNCTIONS – Indicators that wetland functions to improve water quality.		(only 1 score per box) (see p.38)
D 1	Does the wetland have the <u>potential</u> to improve water quality?	
D 1.1	Characteristics of surface water flows out of the wetland: • Unit is a depression with no surface water leaving it (no outlet) points = 3 <input type="checkbox"/> • Unit has an intermittently flowing, OR highly constricted, permanently flowing outlet ... points = 2 <input checked="" type="checkbox"/> • Unit has an unconstricted, or slightly constricted, surface outlet (<i>permanently flowing</i>) .. points = 1 <input type="checkbox"/> • Unit is a “flat” depression (Q.7 on key), or in the Flats class, with permanent surface outflow and no obvious natural outlet and/or outlet is a man-made ditch..... points = 1 <input type="checkbox"/> <i>(If ditch is not permanently flowing treat unit as “intermittently flowing”)</i> Provide photo or drawing	Figure <input type="checkbox"/> 2
D 1.2	The soil 2 inches below the surface (or duff layer) is clay or organic (<i>use NRCS definitions</i>) YES points = 4 NO points = 0	0
D 1.3	Characteristics of persistent vegetation (emergent, shrub, and/or forest Cowardin class): • Wetland has persistent, ungrazed vegetation > = 95% of area points = 5 <input type="checkbox"/> • Wetland has persistent, ungrazed vegetation > = 1/2 of area points = 3 <input checked="" type="checkbox"/> • Wetland has persistent, ungrazed vegetation > = 1/10 of area points = 1 <input type="checkbox"/> • Wetland has persistent, ungrazed vegetation < 1/10 of area points = 0 <input type="checkbox"/> Map of Cowardin vegetation classes	Figure <input type="checkbox"/> 3
D 1.4	Characteristics of seasonal ponding or inundation: <i>This is the area of the wetland that is ponded for at least 2 months, but dries out sometime during the year. Do not count the area that is permanently ponded. Estimate area as the average condition 5 out of 10 years.</i> • Area seasonally ponded is > 1/2 total area of wetland points = 4 <input checked="" type="checkbox"/> • Area seasonally ponded is > 1/4 total area of wetland points = 2 <input type="checkbox"/> • Area seasonally ponded is < 1/4 total area of wetland points = 0 <input type="checkbox"/> Map of Hydroperiods	Figure <input type="checkbox"/> 4
Total for D 1		<i>Add the points in the boxes above</i> 9
D 2	Does the wetland have the <u>opportunity</u> to improve water quality?	(see p. 44)
Answer YES if you know or believe there are pollutants in groundwater or surface water coming into the wetland that would otherwise reduce water quality in streams, lakes or groundwater downgradient from the wetland? <i>Note which of the following conditions provide the sources of pollutants. A unit may have pollutants coming from several sources, but any single source would qualify as opportunity.</i> <input type="checkbox"/> Grazing in the wetland or within 150 ft <input checked="" type="checkbox"/> Untreated stormwater discharges to wetland <input type="checkbox"/> Tilled fields or orchards within 150 ft. of wetland <input checked="" type="checkbox"/> A stream or culvert discharges into wetland that drains developed areas, residential areas, farmed fields, roads, or clear-cut logging <input checked="" type="checkbox"/> Residential, urban areas, golf courses are within 150 ft. of wetland <input type="checkbox"/> Wetland is fed by groundwater high in phosphorus or nitrogen <input type="checkbox"/> Other _____		Multiplier 2
<input checked="" type="checkbox"/> YES multiplier is 2 <input type="checkbox"/> NO multiplier is 1		
◆ TOTAL – Water Quality Functions		Multiply the score from D1 by D2; then add score to table on p. 1 18
HYDROLOGIC FUNCTIONS – Indicators that wetland unit functions to reduce flooding and stream degradation.		
D 3	Does the wetland have the <u>potential</u> to reduce flooding and erosion?	(see p.46)
D 3.1	Characteristics of surface water flows out of the wetland unit • Unit is a depression with no surface water leaving it (no outlet) points = 4 <input type="checkbox"/> • Unit has an intermittently flowing, OR highly constricted permanently flowing outlet points = 2 <input checked="" type="checkbox"/> • Unit is a “flat” depression (Q.7 on key) or in the Flats class, with permanent surface outflow and no obvious natural outlet and/or outlet is a man-made ditch..... points = 1 <input type="checkbox"/> <i>(If ditch is not permanently flowing treat unit as “intermittently flowing”)</i> • Unit has an unconstricted, or slightly constricted, surface outlet (<i>permanently flowing</i>) points = 0	2
D 3.2	Depth of storage during wet periods. <i>Estimate the height of ponding above the bottom of the outlet. For units with no outlet measure from the surface of permanent water or deepest part (if dry).</i> • Marks of ponding are 3 ft. or more above the surface or bottom of the outlet points = 7 <input type="checkbox"/> • The wetland is a “headwater” wetland..... points = 5 <input type="checkbox"/> • Marks of ponding between 2 ft. to < 3 ft. from surface or bottom of outlet points = 5 <input type="checkbox"/> • Marks are at least 0.5 ft. to < 2 ft. from surface or bottom of outlet points = 3 <input checked="" type="checkbox"/> • Wetland is flat (yes to Q.2 or Q.7 on key) but has small depressions on the surface that trap water . points = 1 <input type="checkbox"/> • Marks of ponding less than 0.5 ft points = 0 <input type="checkbox"/>	3
D 3.3	Contribution of wetland unit to storage in the watershed: <i>Estimate the ratio of the area of upstream basin contributing surface water to the wetland to the area of the wetland unit itself.</i> • The area of the basin is less than 10 times the area of unit..... points = 5 <input type="checkbox"/> • The area of the basin is 10 to 100 times the area of the unit..... points = 3 <input checked="" type="checkbox"/> • The area of the basin is more than 100 times the area of the unit points = 0 <input type="checkbox"/> • Entire unit is in the FLATS class points = 5 <input type="checkbox"/>	3
Total for D 3		<i>Add the points in the boxes above</i> 8

D 4	<p>Does the wetland have the <u>opportunity</u> to reduce flooding and erosion?</p> <p>Answer YES if the unit is in a location in the watershed where the flood storage, or reduction in water velocity, it provides helps protect downstream property and aquatic resources from flooding or excessive and/or erosive flows. Answer NO if the water coming into the wetland is controlled by a structure such as flood gate, tide gate, flap valve, reservoir etc. OR you estimate that more than 90% of the water in the wetland is from groundwater in areas where damaging groundwater flooding does not occur. <i>Note which of the following indicators of opportunity apply.</i></p> <p><input type="checkbox"/> Wetland is in a headwater of a river or stream that has flooding problems.</p> <p><input checked="" type="checkbox"/> Wetland drains to a river or stream that has flooding problems</p> <p><input type="checkbox"/> Wetland has no outlet and impounds surface runoff water that might otherwise flow into a river or stream that has flooding problems</p> <p><input type="checkbox"/> Other _____</p> <p><input checked="" type="checkbox"/> YES multiplier is 2 <input type="checkbox"/> NO multiplier is 1</p>	<p>(see p. 49)</p> <p>Multiplier</p> <p>2</p>
◆	<p>TOTAL – Hydrologic Functions Multiply the score from D3 by D4; then <i>add score to table on p. 1</i></p>	<p><u>16</u></p>

Comments: _____

These questions apply to wetlands of all HGM classes.		Points																
HABITAT FUNCTIONS – Indicators that wetland functions to provide important habitat.		(only 1 score per box)																
H 1	Does the wetland have the potential to provide habitat for many species?																	
H 1.1	<p>Vegetation structure (see P. 72): Check the types of vegetation classes present (as defined by Cowardin) – Size threshold for each class is 1/4 acre or more than 10% of the area if unit is smaller than 2.5 acres.</p> <p><input type="checkbox"/> Aquatic Bed <input checked="" type="checkbox"/> Emergent plants <input checked="" type="checkbox"/> Scrub/shrub (areas where shrubs have > 30% cover) <input checked="" type="checkbox"/> Forested (areas where trees have > 30% cover)</p> <p>If the unit has a forested class check if: <input type="checkbox"/> The forested class has 3 out of 5 strata (canopy, sub-canopy, shrubs, herbaceous, moss/ground-cover) that each cover 20% within the forested polygon.</p> <p>Add the number of vegetation types that qualify. If you have:</p> <table style="width: 100%; border: none;"> <tr> <td style="width: 50%;">4 structures or more..... points = 4</td> <td style="width: 50%; text-align: right;">Map of Cowardin vegetation classes</td> </tr> <tr> <td>2 structures..... points = 1</td> <td style="text-align: right;">3 structures..... points = 2</td> </tr> <tr> <td></td> <td style="text-align: right;">1 structure..... points = 0</td> </tr> </table>	4 structures or more..... points = 4	Map of Cowardin vegetation classes	2 structures..... points = 1	3 structures..... points = 2		1 structure..... points = 0	<p>Figure <input type="checkbox"/></p> <p style="text-align: right;">2</p>										
4 structures or more..... points = 4	Map of Cowardin vegetation classes																	
2 structures..... points = 1	3 structures..... points = 2																	
	1 structure..... points = 0																	
H 1.2	<p>Hydroperiods (see p.73): Check the types of water regimes (hydroperiods) present within the wetland. The water regime has to cover more than 10% of the wetland or 1/4 acre to count (see text for descriptions of hydroperiods).</p> <table style="width: 100%; border: none;"> <tr> <td style="width: 50%;"><input type="checkbox"/> Permanently flooded or inundated</td> <td style="width: 50%;">4 or more types present</td> <td style="width: 50%;">points = 3</td> <td style="width: 50%;"><input type="checkbox"/></td> </tr> <tr> <td><input checked="" type="checkbox"/> Seasonally flooded or inundated</td> <td>3 or more types present</td> <td>points = 2</td> <td><input type="checkbox"/></td> </tr> <tr> <td><input checked="" type="checkbox"/> Occasionally flooded or inundated</td> <td>2 types present</td> <td>points = 1</td> <td><input checked="" type="checkbox"/></td> </tr> <tr> <td><input checked="" type="checkbox"/> Saturated only</td> <td>1 type present</td> <td>points = 0</td> <td><input type="checkbox"/></td> </tr> </table> <p><input type="checkbox"/> Permanently flowing stream or river in, or adjacent to, the wetland <input type="checkbox"/> Seasonally flowing stream in, or adjacent to, the wetland</p> <p><input type="checkbox"/> Lake-fringe wetland..... = 2 points <input type="checkbox"/> Freshwater tidal wetland..... = 2 points</p> <p style="text-align: right;">Map of hydroperiods</p>	<input type="checkbox"/> Permanently flooded or inundated	4 or more types present	points = 3	<input type="checkbox"/>	<input checked="" type="checkbox"/> Seasonally flooded or inundated	3 or more types present	points = 2	<input type="checkbox"/>	<input checked="" type="checkbox"/> Occasionally flooded or inundated	2 types present	points = 1	<input checked="" type="checkbox"/>	<input checked="" type="checkbox"/> Saturated only	1 type present	points = 0	<input type="checkbox"/>	<p>Figure <input type="checkbox"/></p> <p style="text-align: right;">1</p>
<input type="checkbox"/> Permanently flooded or inundated	4 or more types present	points = 3	<input type="checkbox"/>															
<input checked="" type="checkbox"/> Seasonally flooded or inundated	3 or more types present	points = 2	<input type="checkbox"/>															
<input checked="" type="checkbox"/> Occasionally flooded or inundated	2 types present	points = 1	<input checked="" type="checkbox"/>															
<input checked="" type="checkbox"/> Saturated only	1 type present	points = 0	<input type="checkbox"/>															
H 1.3	<p>Richness of Plant Species (see p. 75): Count the number of plant species in the wetland that cover at least 10 ft² (different patches of the same species can be combined to meet the size threshold) You do not have to name the species. Do not include Eurasian Milfoil, reed canarygrass, purple loosestrife, Canadian Thistle.</p> <p>If you counted:</p> <table style="width: 100%; border: none;"> <tr> <td style="width: 50%;">> 19 species..... points = 2</td> <td style="width: 50%;"><input type="checkbox"/></td> </tr> <tr> <td>5 – 19 species..... points = 1</td> <td><input checked="" type="checkbox"/></td> </tr> <tr> <td>< 5 species..... points = 0</td> <td><input type="checkbox"/></td> </tr> </table> <p>List species below if you want to: _____</p>	> 19 species..... points = 2	<input type="checkbox"/>	5 – 19 species..... points = 1	<input checked="" type="checkbox"/>	< 5 species..... points = 0	<input type="checkbox"/>	<p style="text-align: right;">1</p>										
> 19 species..... points = 2	<input type="checkbox"/>																	
5 – 19 species..... points = 1	<input checked="" type="checkbox"/>																	
< 5 species..... points = 0	<input type="checkbox"/>																	
H 1.4	<p>Interspersion of Habitats (see p. 76): Decided from the diagrams below whether interspersion between Cowardin vegetation (described in H1.1), or the classes and unvegetated areas (can include open water or mudflats) is high, medium, low, or none.</p> <div style="text-align: center;"> <p>None = 0 points Low = 1 point Moderate = 2 points</p> <p>High = 3 points [riparian braided channels]</p> </div> <p>Note: If you have 4 or more classes or 3 vegetation classes and open water, the rating is always “high”.</p> <p style="text-align: right;">Use map of Cowardin classes.</p>	<p>Figure <input type="checkbox"/></p> <p style="text-align: right;">3</p>																
H 1.5	<p>Special Habitat Features (see p. 77): Check the habitat features that are present in the wetland. The number of checks is the number of points you put into the next column.</p> <p><input checked="" type="checkbox"/> Large, downed, woody debris within the wetland (> 4 in. diameter and 6 ft. long) <input checked="" type="checkbox"/> Standing snags (diameter at the bottom > 4 inches) in the wetland <input type="checkbox"/> Undercut banks are present for at least 6.6 ft. (2m) and/or overhanging vegetation extends at least 3.3 ft. (1m) over a stream (or ditch) in, or contiguous with the unit, for at least 33 ft. (10m) <input type="checkbox"/> Stable steep banks of fine material that might be used by beaver or muskrat for denning (> 30 degree slope) OR signs of recent beaver activity are present (cut shrubs or trees that have not yet turned grey/brown) <input type="checkbox"/> At least 1/4 acre of thin-stemmed persistent vegetation or woody branches are present in areas that are permanently or seasonally inundated (structures for egg-laying by amphibians) <input type="checkbox"/> Invasive plants cover less than 25% of the wetland area in each stratum of plants</p> <p>NOTE: The 20% stated in early printings of the manual on page 78 is an error.</p>	<p style="text-align: right;">2</p>																
H 1 TOTAL Score – potential for providing habitat		Add the points in the column above																
		9																

H 2	Does the wetland have the <u>opportunity</u> to provide habitat for many species?	(only 1 score per box)
	<p>H 2.1 <u>Buffers</u> (see P. 80): Choose the description that best represents condition of buffer of wetland unit. The highest scoring criterion that applies to the wetland is to be used in the rating. See text for definition of "undisturbed".</p> <p><input type="checkbox"/> 100m (330 ft) of relatively undisturbed vegetated areas, rocky areas, or open water > 95% of circumference. No structures are within the undisturbed part of buffer (relatively undisturbed also means no grazing, no landscaping, no daily human use)..... points = 5</p> <p><input type="checkbox"/> 100m (330 ft) of relatively undisturbed vegetated areas, rocky areas, or open water > 50% circumference points = 4</p> <p><input type="checkbox"/> 50m (170 ft) of relatively undisturbed vegetated areas, rocky areas, or open water > 95% circumference points = 4</p> <p><input type="checkbox"/> 100m (330 ft) of relatively undisturbed vegetated areas, rocky areas, or open water > 25% circumference points = 3</p> <p><input type="checkbox"/> 50m (170 ft) of relatively undisturbed vegetated areas, rocky areas, or open water for > 50% circumference points = 3</p> <p>If buffer does not meet any of the criteria above:</p> <p><input type="checkbox"/> No paved areas (except paved trails) or buildings within 25m (80 ft) of wetland > 95% circumference. Light to moderate grazing or lawns are OK points = 2</p> <p><input type="checkbox"/> No paved areas of buildings within 50m of wetland for > 50% circumference. Light to moderate grazing or lawns are OK points = 2</p> <p><input type="checkbox"/> Heavy grazing in buffer points = 1</p> <p><input type="checkbox"/> Vegetated buffers are < 2m wide (6.6 ft) for more than 95% circumference (e.g. tilled fields, paving, basalt bedrock extend to edge of wetland) points = 0</p> <p><input checked="" type="checkbox"/> Buffer does not meet any of the criteria above points = 1</p> <p style="text-align: right;">Arial photo showing buffers</p>	<p>Figure <input type="checkbox"/></p> <p style="text-align: center;">1</p>
	<p>H 2.2 <u>Corridors and Connections</u> (see p. 81)</p> <p>H 2.2.1 Is the wetland part of a relatively undisturbed and unbroken vegetated corridor (either riparian or upland) that is at least 150 ft. wide, has at least a 30% cover of shrubs, forest or native undisturbed prairie, that connects to estuaries, other wetlands or undisturbed uplands that are at least 250 acres in size? (<i>Dams in riparian corridors, heavily used gravel roads, paved roads, are considered breaks in the corridor.</i>)</p> <p style="padding-left: 40px;"><input type="checkbox"/> YES = 4 points (go to H 2.3) <input checked="" type="checkbox"/> NO = go to H 2.2.2</p> <p>H. 2.2.2 Is the wetland part of a relatively undisturbed and unbroken vegetated corridor (either riparian or upland) that is at least 50 ft. wide, has at least 30% cover of shrubs or forest, and connects to estuaries, other wetlands or undisturbed uplands that are at least 25 acres in size? OR a Lake-fringe wetland, if it does not have an undisturbed corridor as in the question above?</p> <p style="padding-left: 40px;"><input type="checkbox"/> YES = 2 points (go to H 2.3) <input checked="" type="checkbox"/> NO = go to H 2.2.3</p> <p>H. 2.2.3 Is the wetland:</p> <ul style="list-style-type: none"> • Within 5 mi (8km) of a brackish or salt water estuary OR • Within 3 miles of a large field or pasture (> 40 acres) OR • Within 1 mile of a lake greater than 20 acres? <p style="text-align: right; padding-right: 40px;"><input type="checkbox"/> YES = 1 point <input checked="" type="checkbox"/> NO = 0 points</p>	<p style="text-align: center;">0</p>

Comments: _____

	<p>H 2.3 <u>Near or adjacent to other priority habitats listed by WDFW</u> (see p. 82): <i>(see new and complete descriptions of WDFW priority habitats, and the counties in which they can be found, in the PHS report http://wdfw.wa.gov/hab/phslist.htm)</i> Which of the following priority habitats are within 330 ft. (100m) of the wetland unit? NOTE: <i>the connections do not have to be relatively undisturbed.</i></p> <p><input type="checkbox"/> Aspen Stands: Pure or mixed stands of aspen greater than 0.4 ha (1 acre).</p> <p><input type="checkbox"/> Biodiversity Areas and Corridors: Areas of habitat that are relatively important to various species of native fish and wildlife <i>(full descriptions in WDFW PHS report p. 152).</i></p> <p><input type="checkbox"/> Herbaceous Balds: Variable size patches of grass and forbs on shallow soils over bedrock.</p> <p><input type="checkbox"/> Old-growth/Mature forests: (Old-growth west of Cascade crest) Stands of at least 2 tree species, forming a multi-layered canopy with occasional small openings; with at least 20 trees/ha (8 trees/acre) > 81 cm (32 in) dbh or > 200 years of age. (Mature forests) Stands with average diameters exceeding 53 cm (21 in) dbh; crown cover may be less than 100%; decay, decadence, numbers of snags, and quantity of large downed material is generally less than that found in old-growth; 80 - 200 years old west of the Cascade crest.</p> <p><input type="checkbox"/> Oregon white Oak: Woodlands Stands of pure oak or oak/conifer associations where canopy coverage of the oak component is important <i>(full descriptions in WDFW PHS report p. 158).</i></p> <p><input type="checkbox"/> Riparian: The area adjacent to aquatic systems with flowing water that contains elements of both aquatic and terrestrial ecosystems which mutually influence each other.</p> <p><input type="checkbox"/> Westside Prairies: Herbaceous, non-forested plant communities that can either take the form of a dry prairie or a wet prairie <i>(full descriptions in WDFW PHS report p. 161).</i></p> <p><input type="checkbox"/> Instream: The combination of physical, biological, and chemical processes and conditions that interact to provide functional life history requirements for instream fish and wildlife resources.</p> <p><input type="checkbox"/> Nearshore: Relatively undisturbed nearshore habitats. These include Coastal Nearshore, Open Coast Nearshore, and Puget Sound Nearshore. <i>(full descriptions of habitats and the definition of relatively undisturbed are in WDFW report: pp. 167-169 and glossary in Appendix A).</i></p> <p><input type="checkbox"/> Caves: A naturally occurring cavity, recess, void, or system of interconnected passages under the earth in soils, rock, ice, or other geological formations and is large enough to contain a human.</p> <p><input type="checkbox"/> Cliffs: Greater than 7.6 m (25 ft) high and occurring below 5000 ft.</p> <p><input type="checkbox"/> Talus: Homogenous areas of rock rubble ranging in average size 0.15 - 2.0 m (0.5 - 6.5 ft), composed of basalt, andesite, and/or sedimentary rock, including riprap slides and mine tailings. May be associated with cliffs.</p> <p><input checked="" type="checkbox"/> Snags and Logs: Trees are considered snags if they are dead or dying and exhibit sufficient decay characteristics to enable cavity excavation/use by wildlife. Priority snags have a diameter at breast height of > 51 cm (20 in) in western Washington and are > 2 m (6.5 ft) in height. Priority logs are > 30 cm (12 in) in diameter at the largest end, and > 6 m (20 ft) long.</p> <p style="text-align: right;">If wetland has 3 or more priority habitats = 4 points If wetland has 2 priority habitats = 3 points If wetland has 1 priority habitat = 1 point No habitats = 0 points</p> <p>Note: All vegetated wetlands are by definition a priority habitat but are not included in this list. Nearby wetlands are addressed in question H 2.4)</p>	1
	<p>H 2.4 <u>Wetland Landscape:</u> <i>Choose the one description of the landscape around the wetland that best fits (see p. 84)</i></p> <ul style="list-style-type: none"> • There are at least 3 other wetlands within 1/2 mile, and the connections between them are relatively undisturbed (light grazing between wetlands OK, as is lake shore with some boating, but connections should NOT be bisected by paved roads, fill, fields, or other development.... points = 5 <input type="checkbox"/> • The wetland is Lake-fringe on a lake with little disturbance and there are 3 other lake-fringe wetlands within 1/2 mile points = 5 <input type="checkbox"/> • There are at least 3 other wetlands within 1/2 mile, BUT the connections between them are disturbed. points = 3 <input checked="" type="checkbox"/> • The wetland fringe on a lake with disturbance and there are 3 other lake-fringe wetlands within 1/2 mile points = 3 <input type="checkbox"/> • There is at least 1 wetland within 1/2 mile points = 2 <input type="checkbox"/> • There are no wetlands within 1/2 mile..... points = 0 <input type="checkbox"/> 	3
	<p>H 2 TOTAL Score – opportunity for providing habitat <i>Add the scores from H2.1, H2.2, H2.3, H2.4</i></p>	5
	<p><i>TOTAL for H 1 from page 8</i></p>	9
◆	<p>Total Score for Habitat Functions Add the points for H 1 and H 2; then record the result on p. 1</p>	14

Comments: _____

CATEGORIZATION BASED ON SPECIAL CHARACTERISTICS

Please determine if the wetland meets the attributes described below and circle the appropriate answers and Category.

Wetland Type – Check off any criteria that apply to the wetland. Circle the Category when the appropriate criteria are met.	
SC1	<p>Estuarine wetlands? (see p.86)</p> <p>Does the wetland unit meet the following criteria for Estuarine wetlands?</p> <p><input type="checkbox"/> The dominant water regime is tidal, <input type="checkbox"/> Vegetated, and <input type="checkbox"/> With a salinity greater than 0.5 ppt.</p> <p style="text-align: center;"><input type="checkbox"/> YES = Go to SC 1.1 <input checked="" type="checkbox"/> NO</p>
	<p>SC 1.1 Is the wetland unit within a National Wildlife Refuge, National Park, National Estuary Reserve, Natural Area Preserve, State Park or Educational, Environmental, or Scientific Reserve designated under WAC 332-30-151? <input type="checkbox"/> YES = Category I <input type="checkbox"/> NO = go to SC 1.2</p>
	<p>SC 1.2 Is the wetland at least 1 acre in size and meets at least two of the following conditions?</p> <p style="text-align: center;"><input type="checkbox"/> YES = Category I <input type="checkbox"/> NO = Category II</p> <p><input type="checkbox"/> The wetland is relatively undisturbed (has no diking, ditching, filling, cultivation, grazing, and has less than 10% cover of non-native plant species. If the non-native <i>Spartina</i> spp. are only species that cover more than 10% of the wetland, then the wetland should be given a dual rating (I/II). The area of <i>Spartina</i> would be rated a Category II while the relatively undisturbed upper marsh with native species would be a Category I. Do not, however, exclude the area of <i>Spartina</i> in determining the size threshold of 1 acre.</p> <p><input type="checkbox"/> At least 3/4 of the landward edge of the wetland has a 100 ft. buffer of shrub, forest, or un-grazed or un-mowed grassland</p> <p><input type="checkbox"/> The wetland has at least 2 of the following features: tidal channels, depressions with open water, or contiguous freshwater wetlands.</p>
SC2	<p>Natural Heritage Wetlands (see p. 87)</p> <p>Natural Heritage wetlands have been identified by the Washington Natural Heritage Program/DNR as either high quality undisturbed wetlands or wetlands that support state Threatened, Endangered, or Sensitive plant species.</p> <p>SC 2.1 Is the wetland being rated in a Section/Township/Range that contains a natural heritage wetland? (This question is used to screen out most sites before you need to contact WNHP/DNR.)</p> <p style="text-align: center;"><input type="checkbox"/> S/T/R information from Appendix D <input type="checkbox"/> or accessed from WNHP/DNR web site <input type="checkbox"/> YES Contact WNHP/DNR (see p. 79) and go to SC 2.2 <input checked="" type="checkbox"/> NO</p> <p>SC 2.2 Has DNR identified the wetland as a high quality undisturbed wetland or as a site with state threatened or endangered plant species?</p> <p style="text-align: center;"><input type="checkbox"/> YES = Category 1 <input checked="" type="checkbox"/> NO not a Heritage Wetland</p>
SC3	<p>Bogs (see p. 87)</p> <p>Does the wetland (or any part of the unit) meet both the criteria for soils and vegetation in bogs? Use the key below to identify if the wetland is a bog. If you answer yes you will still need to rate the wetland based on its function.</p> <ol style="list-style-type: none"> Does the unit have organic soil horizons (i.e. layers of organic soil), either peats or mucks, that compose 16 inches or more of the first 32 inches of soil profile? (See Appendix B for a field key to identify organic soils)? <input type="checkbox"/> YES = go to question 3 <input checked="" type="checkbox"/> NO = go to question 2 Does the wetland have organic soils, either peats or mucks that are less than 16 inches deep over bedrock, or an impermeable hardpan such as clay or volcanic ash, or that are floating on a lake or pond? <input type="checkbox"/> YES = go to question 3 <input checked="" type="checkbox"/> NO = is not a bog for purpose of rating Does the unit have more than 70% cover of mosses at ground level, AND other plants, if present, consist of the “bog” species listed in Table 3 as a significant component of the vegetation (more than 30% of the total shrub and herbaceous cover consists of species in Table 3)? <p style="text-align: center;"><input type="checkbox"/> YES = Is a bog for purpose of rating <input checked="" type="checkbox"/> NO = go to question 4</p> <p>NOTE: If you are uncertain about the extent of mosses in the understory you may substitute that criterion by measuring the pH of the water that seeps into a hole dug at least 16” deep. If the pH is less than 5.0 and the “bog” plant species in Table 3 are present, the wetland is a bog.</p> <ol style="list-style-type: none"> Is the unit forested (> 30% cover) with sitka spruce, subalpine fir, western red cedar, western hemlock, lodgepole pine, quaking aspen, Englemann’s spruce, or western white pine. WITH any of the species (or combination of species) on the bog species plant list in Table 3 as a significant component of the ground cover (> 30% coverage of the total shrub/herbaceous cover)? <p style="text-align: center;"><input type="checkbox"/> YES = Category I <input checked="" type="checkbox"/> NO = Is not a bog for purpose of rating</p>

SC4	<p>Forested Wetlands (see p. 90)</p> <p>Does the wetland have at least 1 acre of forest that meet one of these criteria for the Department of Fish and Wildlife’s forests as priority habitats? <i>If you answer yes you will still need to rate the wetland based on its function.</i></p> <p><input type="checkbox"/> Old-growth forests: (west of Cascade Crest) Stands of at least two three species forming a multi-layered canopy with occasional small openings; with at least 8 trees/acre (20 trees/hectare) that are at least 200 years of age OR have a diameter at breast height (dbh) of 32 inches (81 cm or more). NOTE: The criterion for dbh is based on measurements for upland forests. Two-hundred year old trees in wetlands will often have a smaller dbh because their growth rates are often slower. The DFW criterion is and “OR” so old-growth forests do not necessarily have to have trees of this diameter.</p> <p><input type="checkbox"/> Mature forests: (west of the Cascade Crest) Stands where the largest trees are 80 – 200 years old OR have an average diameters (dbh) exceeding 21 inches (53 cm); crown cover may be less than 100%; decay, decadence, numbers of snags, and quantity of large downed material is generally less than that found in old-growth.</p> <p><input type="checkbox"/> YES = Category I <input checked="" type="checkbox"/> NO = not a forested wetland with special characteristics</p>	<p>Cat. I <input type="checkbox"/></p>
SC5	<p>Wetlands in Coastal Lagoons (see p. 91)</p> <p>Does the wetland meet all of the following criteria of a wetland in a coastal lagoon?</p> <p><input type="checkbox"/> The wetland lies in a depression adjacent to marine waters that is wholly or partially separated from marine waters by sandbanks, gravel banks, shingle, or, less frequently, rocks.</p> <p><input type="checkbox"/> The lagoon in which the wetland is located contains surface water that is saline or brackish (> 0.5 ppt) during most of the year in at least a portion of the lagoon (<i>needs to be measured near the bottom.</i>)</p> <p><input type="checkbox"/> YES = Go to SC 5.1 <input checked="" type="checkbox"/> NO not a wetland in a coastal lagoon</p> <p>SC 5.1 Does the wetland meet all of the following three conditions?</p> <p><input type="checkbox"/> The wetland is relatively undisturbed (has no diking, ditching, filling, cultivation, grazing) and has less than 20% cover of invasive plant species (see list of invasive species on p. 74).</p> <p><input type="checkbox"/> At least 3/4 of the landward edge of the wetland has a 100 ft. buffer of shrub, forest, or un-grazed or un-mowed grassland.</p> <p><input type="checkbox"/> The wetland is larger than 1/10 acre (4350 square ft.)</p> <p><input type="checkbox"/> YES = Category I <input type="checkbox"/> NO = Category II</p>	<p>Cat. I <input type="checkbox"/></p> <p>Cat. II <input type="checkbox"/></p>
SC6	<p>Interdunal Wetlands (see p. 93)</p> <p>Is the wetland west of the 1889 line (also called the Western Boundary of Upland Ownership or WBUO)?</p> <p><input type="checkbox"/> YES = Go to SC 6.1 <input checked="" type="checkbox"/> NO not an interdunal wetland for rating</p> <p><i>If you answer yes you will still need to rate the wetland based on its functions.</i></p> <p>In practical terms that means the following geographic areas:</p> <ul style="list-style-type: none"> • Long Beach Peninsula -- lands west of SR 103 • Grayland-Westport -- lands west of SR 105 • Ocean Shores-Copalis – lands west of SR 115 and SR 109 <p>SC 6.1 Is the wetland one acre or larger, or is it in a mosaic of wetlands that is one acre or larger?</p> <p><input type="checkbox"/> YES = Category II <input type="checkbox"/> NO = go to SC 6.2</p> <p>SC 6.2 Is the wetland between 0.1 and 1 acre, or is it in a mosaic of wetlands that is between 0.1 and 1 acre?</p> <p><input type="checkbox"/> YES = Category III</p>	<p>Cat. II <input type="checkbox"/></p> <p>Cat. III <input type="checkbox"/></p>
◆	<p>Category of wetland based on Special Characteristics</p> <p><i>Choose the “highest” rating if wetland falls into several categories, and record on p. 1.</i></p> <p>If you answered NO for all types enter “Not Applicable” on p. 1</p>	<p>NA</p>

Comments:

WETLAND RATING FORM – WESTERN WASHINGTON
Version 2 – Updated July 2006 to increase accuracy and reproducibility among users
Updated Oct. 2008 with the new WDFW definitions for priority habitats

Name of wetland (if known): Valley Creek

Date of site visit: April 23, 2013

Rated by: C. Douglas & J. Pursley Trained by Ecology? Yes No

Date of training: May 2007

SEC: 28 TOWNSHP: 24N RNGE: 5E

Is S/T/R in Appendix D? Yes No

Map of wetland unit: Figure _____ Estimated size _____

SUMMARY OF RATING

Category based on FUNCTIONS provided by wetland: I II III IV

Category I =	Score > 70
Category II =	Score 51 - 69
Category III =	Score 30 – 50
Category IV =	Score < 30

Score for Water Quality Functions	16
Score for Hydrologic Functions	18
Score for Habitat Functions	17
TOTAL Score for Functions	51

Category based on SPECIAL CHARACTERISTICS of Wetland I II Does not apply

Final Category (choose the “highest” category from above”)

II

Summary of basic information about the wetland unit.

Wetland Unit has Special Characteristics		Wetland HGM Class used for Rating	
Estuarine	<input type="checkbox"/>	Depressional	<input type="checkbox"/>
Natural Heritage Wetland	<input type="checkbox"/>	Riverine	<input checked="" type="checkbox"/>
Bog	<input type="checkbox"/>	Lake-fringe	<input type="checkbox"/>
Mature Forest	<input type="checkbox"/>	Slope	<input checked="" type="checkbox"/>
Old Growth Forest	<input type="checkbox"/>	Flats	<input type="checkbox"/>
Coastal Lagoon	<input type="checkbox"/>	Freshwater Tidal	<input type="checkbox"/>
Interdunal	<input type="checkbox"/>		<input type="checkbox"/>
None of the above	<input checked="" type="checkbox"/>	Check if unit has multiple HGM classes present	<input checked="" type="checkbox"/>

Does the wetland being rated meet any of the criteria below? If you answer YES to any of the questions below you will need to protect the wetland according to the regulations regarding the special characteristics found in the wetland.

Check List for Wetlands that Need Additional Protection (in addition to the protection recommended for its category)	YES	NO
SP1. <i>Has the wetland unit been documented as a habitat for any Federally listed Threatened or Endangered animal or plant species (T/E species)?</i> For the purposes of this rating system, “documented” means the wetland is on the appropriate state or federal database.	<input checked="" type="checkbox"/>	<input type="checkbox"/>
SP2. <i>Has the wetland unit been documented as habitat for any State listed Threatened or Endangered animal species?</i> For the purposes of this rating system, “documented” means the wetland is on the appropriate state database. Note: Wetlands with State listed plant species are categorized as Category 1 Natural Heritage Wetlands (see p. 19 of data form).	<input checked="" type="checkbox"/>	<input type="checkbox"/>
SP3. <i>Does the wetland unit contain individuals of Priority species listed by the WDFW for the state?</i>	<input checked="" type="checkbox"/>	<input type="checkbox"/>
SP4. <i>Does the wetland unit have a local significance in addition to its functions?</i> For example, the wetland has been identified in the Shoreline Master Program, the Critical Areas Ordinance, or in a local management plan as having special significance.	<input type="checkbox"/>	<input checked="" type="checkbox"/>

To complete the next part of the data sheet you will need to determine the Hydrogeomorphic Class of the wetland being rated.

The hydrogeomorphic classification groups wetlands in to those that function in similar ways. This simplifies the questions needed to answer how well the wetland functions. The Hydrogeomorphic Class of a wetland can be determined using the key below. See p. 24 for more detailed instructions on classifying wetlands.

Classification of Vegetated Wetlands for Western Washington

If the hydrologic criteria listed in each question do not apply to the entire unit being rated, you probably have a unit with multiple HGM classes. In this case, identify which hydrologic criteria in questions 1-7 apply, and go to Question 8.

1. Are the water levels in the entire unit usually controlled by tides (i.e. except during floods)?
 NO – go to 2 YES – the wetland class is **Tidal Fringe**
 If yes, is the salinity of the water during periods of annual low flow below 0.5 ppt (parts per thousand)?
 YES – **Freshwater Tidal Fringe** NO – **Saltwater Tidal Fringe (Estuarine)**
*If your wetland can be classified as a Freshwater Tidal Fringe use the forms for **Riverine** wetlands. If it is a Saltwater Tidal Fringe it is rated as an **Estuarine** wetland. Wetlands that were call estuarine in the first and second editions of the rating system are called Salt Water Tidal Fringe in the Hydrogeomorphic Classification. Estuarine wetlands were categorized separately in the earlier editions, and this separation is being kept in this revision. To maintain consistency between editions, the term “Estuarine” wetland is kept. Please note, however, that the characteristics that define Category I and II estuarine wetlands have changed (see p. _____).*
-
2. The entire wetland unit is flat and precipitation is only source (>90%) of water to it. Groundwater and surface water runoff are NOT sources of water to the unit.
 NO – go to 3 YES – The wetland class is **Flats**
 If your wetland can be classified as a “Flats” wetland, use the form for **Depressional** wetlands.
-
3. Does the entire wetland meet both of the following criteria?
 The vegetated part of the wetland is on the shores of a body of permanent open water (without any vegetation on the surface) where at least 20 acres (8ha) in size;
 At least 30% of the open water area is deeper than 6.6 (2 m)?
 NO – go to 4 YES – The wetland class is **Lake-fringe (Lacustrine Fringe)**
-
4. Does the entire wetland meet all of the following criteria?
 The wetland is on a slope (*slope can be very gradual*).
 The water flows through the wetland in one direction (unidirectional) and usually comes from seeps. It may flow subsurface, as sheetflow, or in a swale without distinct banks.
 The water leaves the wetland **without being impounded**?
 NOTE: *Surface water does not pond in these types of wetlands except occasionally in very small and shallow depressions or behind hummocks (depressions are usually <3 ft diameter and less than 1 foot deep).*
 NO – go to 5 YES – The wetland class is **Slope**
-
5. Does the entire wetland meet all of the following criteria?
 The unit is in a valley or stream channel where it gets inundated by overbank flooding from that stream or river.
 The overbank flooding occurs at least once every two years.
 NOTE: *The riverine unit can contain depressions that are filled with water when the river is not flooding..*
 NO – go to 6 YES – The wetland class is **Riverine**
-
6. Is the entire wetland unit in a topographic depression in which water ponds, or is saturated to the surface, at some time of the year. This means that any outlet, if present is higher than the interior of the wetland.
 NO – go to 7 YES – The wetland class is **Depressional**
-
7. Is the entire wetland located in a very flat area with no obvious depression and no overbank flooding. The unit does not pond surface water more than a few inches. The unit seems to be maintained by high groundwater in the area. The wetland may be ditched, but has no obvious natural outlet.
 No – go to 8 YES – The wetland class is **Depressional**
-
8. Your wetland unit seems to be difficult to classify and probably contains several different HGM classes. For example, seeps at the base of a slope may grade into a riverine floodplain, or a small stream within a depressional wetland has a zone of flooding along its sides. GO BACK AND IDENTIFY WHICH OF THE HYDROLOGIC REGIMES DESCRIBED IN QUESTIONS 1-7 APPLY TO DIFFERENT AREAS IN THE UNIT (make a rough sketch to help you decide). Use the following table to identify the appropriate class to use for the rating system if you have several HGM classes present within your wetland. NOTE: Use this table only if the class that is recommended in the second column represents 10% or more of the total area of the wetland unit being rated. If the area of the class listed in column 2 is less than 10% of the unit, classify the wetland using the class that represents more than 90% of the total area.

HGM Classes within the wetland unit being rated	HGM Class to Use in Rating
Slope + Riverine	Riverine
Slope + Depressional	Depressional
Slope + Lake-fringe	Lake-fringe
Depressional + Riverine along stream within boundary	Depressional
Depressional + Lake-fringe	Depressional
Salt Water Tidal Fringe and any other class of freshwater wetland	Treat as ESTUARINE under wetlands with special characteristics

If you are unable still to determine which of the above criteria apply to your wetland, or you have more than 2 HGM classes within a wetland boundary, classify the wetland as **Depressional** for the rating.

R Riverine and Freshwater Tidal Fringe Wetlands		Points
WATER QUALITY FUNCTIONS – Indicators that wetland functions to improve water quality.		(only 1 score per box)
R 1	Does the wetland have the <u>potential</u> to improve water quality? (see p.52)	
	R 1.1 Area of surface depressions within the riverine wetland that can trap sediments during a flooding event: <ul style="list-style-type: none"> • Depressions cover > 3/4 area of wetland points = 8 <input type="checkbox"/> • Depressions cover > 1/2 area of wetland points = 4 <input type="checkbox"/> (If depressions > 1/2 of area of unit draw polygons on aerial photo or map) • Depressions present but cover < 1/2 area of wetland. points = 2 <input checked="" type="checkbox"/> • No depressions present points = 0 <input type="checkbox"/> 	Figure <input type="checkbox"/> 2
	R 1.2 Characteristics of the vegetation in the unit (areas with >90% cover at person height): <ul style="list-style-type: none"> • Trees or shrubs > 2/3 area of the unit points = 8 <input type="checkbox"/> • Trees or shrubs > 1/3 area of the wetland points = 6 <input checked="" type="checkbox"/> • Ungrazed, herbaceous plants > 2/3 area of unit points = 6 <input type="checkbox"/> • Ungrazed herbaceous plants > 1/3 area of unit points = 3 <input type="checkbox"/> • Trees, shrubs, and ungrazed herbaceous < 1/3 area of unit points = 0 <input type="checkbox"/> 	Figure <input type="checkbox"/> 6
Aerial photo or map showing polygons of different vegetation types		
Add the points in the boxes above		8
R 2	Does the wetland have the <u>opportunity</u> to improve water quality?	(see p. 53)
	Answer YES if you know or believe there are pollutants in groundwater or surface water coming into the wetland that would otherwise reduce water quality in streams, lakes or groundwater downgradient from the wetland. <i>Note which of the following conditions provide the sources of pollutants. A unit may have pollutants coming from several sources, but any single source would qualify as opportunity.</i> <ul style="list-style-type: none"> <input type="checkbox"/> Grazing in the wetland or within 150 ft <input checked="" type="checkbox"/> Untreated stormwater discharges to wetland <input checked="" type="checkbox"/> Tilled fields or orchards within 150 ft. of wetland <input checked="" type="checkbox"/> A stream or culvert discharges into wetland that drains developed areas, residential areas, farmed fields, roads, or clear-cut logging <input checked="" type="checkbox"/> Residential, urban areas, golf courses are within 150 ft. of wetland <input type="checkbox"/> The river or stream linked to the wetland has a contributing basin where human activities have raised levels of sediment, toxic compounds or nutrients in the river water above standards for water quality. <input type="checkbox"/> Other _____ 	Multiplier 2
YES multiplier is 2 NO multiplier is 1		
◆ TOTAL – Water Quality Functions Multiply the score from R1 by R2; then <i>add score to table on p. 1</i>		16
HYDROLOGIC FUNCTIONS – Indicators that wetland functions to reduce flooding and stream erosion.		
R 3	Does the wetland have the <u>potential</u> to reduce flooding and erosion?	(see p.54)
	R 3.1 Characteristics of the overbank storage the wetland provides: <i>Estimate the average width of the wetland perpendicular to the direction of the flow and the width of the stream or river channel (distance between banks). Calculate the ratio: (average width of unit) / (average width of stream between banks).</i> <ul style="list-style-type: none"> • If the ratio is more than 20 points = 9 <input type="checkbox"/> • If the ratio is between 10 – 20 points = 6 <input type="checkbox"/> • If the ratio is 5- <10 points = 4 <input type="checkbox"/> • If the ratio is 1- <5 points = 2 <input checked="" type="checkbox"/> • If the ratio is < 1 points = 1 <input type="checkbox"/> 	Figure <input type="checkbox"/> 2
	R 3.2 Characteristics of vegetation that slow down water velocities during floods: <i>Treat large woody debris as “forest or shrub”. Choose the points appropriate for the best description. (polygons need to have >90% cover at person height NOT Cowardin classes):</i> <ul style="list-style-type: none"> • Forest or shrub for > 1/3 area OR herbaceous plants > 2/3 area points = 7 <input checked="" type="checkbox"/> • Forest or shrub for > 1/10 area OR herbaceous plants > 1/3 area points = 4 <input type="checkbox"/> • Vegetation does not meet above criteria points = 0 <input type="checkbox"/> 	Figure <input type="checkbox"/> 7
Aerial photo or map showing polygons of different vegetation types		
Add the points in the boxes above		9
R 4	Does the wetland have the <u>opportunity</u> to reduce flooding and erosion?	(see p.57)
	Answer YES if the wetland is in a location in the watershed where the flood storage, or reduction in water velocity, it provides helps protect downstream property and aquatic resources from flooding or excessive and/or erosive flows. <i>Note which of the following conditions apply.</i> <ul style="list-style-type: none"> <input checked="" type="checkbox"/> There are human structures and activities downstream (roads, buildings, bridges, farms) that can be damaged by flooding. <input checked="" type="checkbox"/> There are natural resources downstream (e.g. salmon redds) that can be damaged by flooding <input type="checkbox"/> Other _____ 	Multiplier 2
(Answer NO if the major source of water to the wetland is controlled by a reservoir or the wetland is tidal fringe along the sides of a dike)		
<input checked="" type="checkbox"/> YES multiplier is 2 <input type="checkbox"/> NO multiplier is 1		
◆ TOTAL – Hydrologic Functions Multiply the score from R3 by R4; then <i>add score to table on p. 1</i>		18

Comments: _____

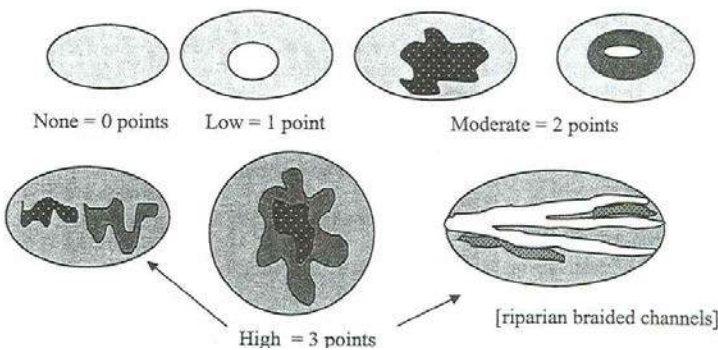
<i>These questions apply to wetlands of all HGM classes.</i>		Points (only 1 score per box)
HABITAT FUNCTIONS – Indicators that wetland functions to provide important habitat.		
H 1	Does the wetland have the potential to provide habitat for many species?	
H 1.1	<p><u>Vegetation structure</u> (see P. 72): Check the types of vegetation classes present (as defined by Cowardin) – Size threshold for each class is 1/4 acre or more than 10% of the area if unit is smaller than 2.5 acres.</p> <p><input type="checkbox"/> Aquatic Bed <input checked="" type="checkbox"/> Emergent plants <input checked="" type="checkbox"/> Scrub/shrub (areas where shrubs have > 30% cover) <input checked="" type="checkbox"/> Forested (areas where trees have > 30% cover)</p> <p>If the unit has a forested class check if: <input type="checkbox"/> The forested class has 3 out of 5 strata (canopy, sub-canopy, shrubs, herbaceous, moss/ground-cover) that each cover 20% within the forested polygon.</p> <p>Add the number of vegetation types that qualify. If you have: Map of Cowardin vegetation classes</p> <p>4 structures or more..... points = 4 <input type="checkbox"/> 3 structures..... points = 2 <input checked="" type="checkbox"/> 2 structures..... points = 1 <input type="checkbox"/> 1 structure..... points = 0 <input type="checkbox"/></p>	<p>Figure <input type="checkbox"/></p> <p style="text-align: right;">2</p>
H 1.2	<p><u>Hydroperiods</u> (see p.73): Check the types of water regimes (hydroperiods) present within the wetland. The water regime has to cover more than 10% of the wetland or 1/4 acre to count (see text for descriptions of hydroperiods).</p> <p><input type="checkbox"/> Permanently flooded or inundated 4 or more types present points = 3 <input type="checkbox"/> <input checked="" type="checkbox"/> Seasonally flooded or inundated 3 or more types present points = 2 <input checked="" type="checkbox"/> <input checked="" type="checkbox"/> Occasionally flooded or inundated 2 types present points = 1 <input type="checkbox"/> <input checked="" type="checkbox"/> Saturated only 1 type present points = 0 <input type="checkbox"/> <input checked="" type="checkbox"/> Permanently flowing stream or river in, or adjacent to, the wetland <input type="checkbox"/> Seasonally flowing stream in, or adjacent to, the wetland</p> <p><input type="checkbox"/> Lake-fringe wetland..... = 2 points <input type="checkbox"/> Freshwater tidal wetland..... = 2 points</p> <p style="text-align: right;">Map of hydroperiods</p>	<p>Figure <input type="checkbox"/></p> <p style="text-align: right;">2</p>
H 1.3	<p><u>Richness of Plant Species</u> (see p. 75): Count the number of plant species in the wetland that cover at least 10 ft² (different patches of the same species can be combined to meet the size threshold) You do not have to name the species. Do not include Eurasian Milfoil, reed canarygrass, purple loosestrife, Canadian Thistle. If you counted: > 19 species points = 2 <input type="checkbox"/> 5 – 19 species..... points = 1 <input checked="" type="checkbox"/> < 5 species points = 0 <input type="checkbox"/></p> <p>List species below if you want to:</p>	<p style="text-align: right;">1</p>
H 1.4	<p><u>Interspersion of Habitats</u> (see p. 76): Decided from the diagrams below whether interspersion between Cowardin vegetation (described in H1.1), or the classes and unvegetated areas (can include open water or mudflats) is high, medium, low, or none.</p> 	<p>Figure <input type="checkbox"/></p> <p style="text-align: right;">3</p>
Note: If you have 4 or more classes or 3 vegetation classes and open water, the rating is always "high". Use map of Cowardin classes.		
H 1.5	<p><u>Special Habitat Features</u> (see p. 77): Check the habitat features that are present in the wetland. The number of checks is the number of points you put into the next column.</p> <p><input checked="" type="checkbox"/> Large, downed, woody debris within the wetland (> 4 in. diameter and 6 ft. long) <input checked="" type="checkbox"/> Standing snags (diameter at the bottom > 4 inches) in the wetland <input type="checkbox"/> Undercut banks are present for at least 6.6 ft. (2m) and/or overhanging vegetation extends at least 3.3 ft. (1m) over a stream (or ditch) in, or contiguous with the unit, for at least 33 ft. (10m) <input type="checkbox"/> Stable steep banks of fine material that might be used by beaver or muskrat for denning (> 30 degree slope) OR signs of recent beaver activity are present (cut shrubs or trees that have not yet turned grey/brown) <input type="checkbox"/> At least 1/4 acre of thin-stemmed persistent vegetation or woody branches are present in areas that are permanently or seasonally inundated (structures for egg-laying by amphibians) <input type="checkbox"/> Invasive plants cover less than 25% of the wetland area in each stratum of plants</p> <p>NOTE: The 20% stated in early printings of the manual on page 78 is an error.</p>	<p style="text-align: right;">2</p>
H 1 TOTAL Score – potential for providing habitat		10
Add the points in the column above		

H 2	Does the wetland have the <u>opportunity</u> to provide habitat for many species?	(only 1 score per box)
	<p>H 2.1 <u>Buffers</u> (see P. 80): Choose the description that best represents condition of buffer of wetland unit. The highest scoring criterion that applies to the wetland is to be used in the rating. See text for definition of "undisturbed".</p> <p><input type="checkbox"/> 100m (330 ft) of relatively undisturbed vegetated areas, rocky areas, or open water > 95% of circumference. No structures are within the undisturbed part of buffer (relatively undisturbed also means no grazing, no landscaping, no daily human use)..... points = 5</p> <p><input type="checkbox"/> 100m (330 ft) of relatively undisturbed vegetated areas, rocky areas, or open water > 50% circumference points = 4</p> <p><input type="checkbox"/> 50m (170 ft) of relatively undisturbed vegetated areas, rocky areas, or open water > 95% circumference points = 4</p> <p><input type="checkbox"/> 100m (330 ft) of relatively undisturbed vegetated areas, rocky areas, or open water > 25% circumference points = 3</p> <p><input type="checkbox"/> 50m (170 ft) of relatively undisturbed vegetated areas, rocky areas, or open water for > 50% circumference points = 3</p> <p>If buffer does not meet any of the criteria above:</p> <p><input type="checkbox"/> No paved areas (except paved trails) or buildings within 25m (80 ft) of wetland > 95% circumference. Light to moderate grazing or lawns are OK points = 2</p> <p><input type="checkbox"/> No paved areas of buildings within 50m of wetland for > 50% circumference. Light to moderate grazing or lawns are OK points = 2</p> <p><input type="checkbox"/> Heavy grazing in buffer points = 1</p> <p><input type="checkbox"/> Vegetated buffers are < 2m wide (6.6 ft) for more than 95% circumference (e.g. tilled fields, paving, basalt bedrock extend to edge of wetland) points = 0</p> <p><input checked="" type="checkbox"/> Buffer does not meet any of the criteria above points = 1</p> <p style="text-align: right;">Arial photo showing buffers</p>	<p>Figure <input type="checkbox"/></p> <p style="text-align: right;">1</p>
	<p>H 2.2 <u>Corridors and Connections</u> (see p. 81)</p> <p>H 2.2.1 Is the wetland part of a relatively undisturbed and unbroken vegetated corridor (either riparian or upland) that is at least 150 ft. wide, has at least a 30% cover of shrubs, forest or native undisturbed prairie, that connects to estuaries, other wetlands or undisturbed uplands that are at least 250 acres in size? (<i>Dams in riparian corridors, heavily used gravel roads, paved roads, are considered breaks in the corridor.</i>)</p> <p style="padding-left: 40px;"><input type="checkbox"/> YES = 4 points (go to H 2.3) <input checked="" type="checkbox"/> NO = go to H 2.2.2</p> <p>H. 2.2.2 Is the wetland part of a relatively undisturbed and unbroken vegetated corridor (either riparian or upland) that is at least 50 ft. wide, has at least 30% cover of shrubs or forest, and connects to estuaries, other wetlands or undisturbed uplands that are at least 25 acres in size? OR a Lake-fringe wetland, if it does not have an undisturbed corridor as in the question above?</p> <p style="padding-left: 40px;"><input type="checkbox"/> YES = 2 points (go to H 2.3) <input checked="" type="checkbox"/> NO = go to H 2.2.3</p> <p>H. 2.2.3 Is the wetland:</p> <ul style="list-style-type: none"> • Within 5 mi (8km) of a brackish or salt water estuary OR • Within 3 miles of a large field or pasture (> 40 acres) OR • Within 1 mile of a lake greater than 20 acres? <p style="text-align: right; padding-right: 40px;"><input type="checkbox"/> YES = 1 point <input checked="" type="checkbox"/> NO = 0 points</p>	<p style="text-align: right;">0</p>

Comments: _____

	<p>H 2.3 <u>Near or adjacent to other priority habitats listed by WDFW</u> (see p. 82): <i>(see new and complete descriptions of WDFW priority habitats, and the counties in which they can be found, in the PHS report http://wdfw.wa.gov/hab/phslist.htm)</i> Which of the following priority habitats are within 330 ft. (100m) of the wetland unit? NOTE: <i>the connections do not have to be relatively undisturbed.</i></p> <p><input type="checkbox"/> Aspen Stands: Pure or mixed stands of aspen greater than 0.4 ha (1 acre).</p> <p><input type="checkbox"/> Biodiversity Areas and Corridors: Areas of habitat that are relatively important to various species of native fish and wildlife <i>(full descriptions in WDFW PHS report p. 152).</i></p> <p><input type="checkbox"/> Herbaceous Balds: Variable size patches of grass and forbs on shallow soils over bedrock.</p> <p><input type="checkbox"/> Old-growth/Mature forests: (Old-growth west of Cascade crest) Stands of at least 2 tree species, forming a multi-layered canopy with occasional small openings; with at least 20 trees/ha (8 trees/acre) > 81 cm (32 in) dbh or > 200 years of age. (Mature forests) Stands with average diameters exceeding 53 cm (21 in) dbh; crown cover may be less than 100%; decay, decadence, numbers of snags, and quantity of large downed material is generally less than that found in old-growth; 80 - 200 years old west of the Cascade crest.</p> <p><input type="checkbox"/> Oregon white Oak: Woodlands Stands of pure oak or oak/conifer associations where canopy coverage of the oak component is important <i>(full descriptions in WDFW PHS report p. 158).</i></p> <p><input checked="" type="checkbox"/> Riparian: The area adjacent to aquatic systems with flowing water that contains elements of both aquatic and terrestrial ecosystems which mutually influence each other.</p> <p><input type="checkbox"/> Westside Prairies: Herbaceous, non-forested plant communities that can either take the form of a dry prairie or a wet prairie <i>(full descriptions in WDFW PHS report p. 161).</i></p> <p><input checked="" type="checkbox"/> Instream: The combination of physical, biological, and chemical processes and conditions that interact to provide functional life history requirements for instream fish and wildlife resources.</p> <p><input type="checkbox"/> Nearshore: Relatively undisturbed nearshore habitats. These include Coastal Nearshore, Open Coast Nearshore, and Puget Sound Nearshore. <i>(full descriptions of habitats and the definition of relatively undisturbed are in WDFW report: pp. 167-169 and glossary in Appendix A).</i></p> <p><input type="checkbox"/> Caves: A naturally occurring cavity, recess, void, or system of interconnected passages under the earth in soils, rock, ice, or other geological formations and is large enough to contain a human.</p> <p><input type="checkbox"/> Cliffs: Greater than 7.6 m (25 ft) high and occurring below 5000 ft.</p> <p><input type="checkbox"/> Talus: Homogenous areas of rock rubble ranging in average size 0.15 - 2.0 m (0.5 - 6.5 ft), composed of basalt, andesite, and/or sedimentary rock, including riprap slides and mine tailings. May be associated with cliffs.</p> <p><input type="checkbox"/> Snags and Logs: Trees are considered snags if they are dead or dying and exhibit sufficient decay characteristics to enable cavity excavation/use by wildlife. Priority snags have a diameter at breast height of > 51 cm (20 in) in western Washington and are > 2 m (6.5 ft) in height. Priority logs are > 30 cm (12 in) in diameter at the largest end, and > 6 m (20 ft) long.</p> <p style="text-align: right;">If wetland has 3 or more priority habitats = 4 points If wetland has 2 priority habitats = 3 points If wetland has 1 priority habitat = 1 point No habitats = 0 points</p> <p>Note: All vegetated wetlands are by definition a priority habitat but are not included in this list. Nearby wetlands are addressed in question H 2.4)</p>	3
	<p>H 2.4 <u>Wetland Landscape:</u> <i>Choose the one description of the landscape around the wetland that best fits (see p. 84)</i></p> <ul style="list-style-type: none"> • There are at least 3 other wetlands within 1/2 mile, and the connections between them are relatively undisturbed (light grazing between wetlands OK, as is lake shore with some boating, but connections should NOT be bisected by paved roads, fill, fields, or other development.... points = 5 <input type="checkbox"/> • The wetland is Lake-fringe on a lake with little disturbance and there are 3 other lake-fringe wetlands within 1/2 mile points = 5 <input type="checkbox"/> • There are at least 3 other wetlands within 1/2 mile, BUT the connections between them are disturbed. points = 3 <input checked="" type="checkbox"/> • The wetland fringe on a lake with disturbance and there are 3 other lake-fringe wetlands within 1/2 mile points = 3 <input type="checkbox"/> • There is at least 1 wetland within 1/2 mile points = 2 <input type="checkbox"/> • There are no wetlands within 1/2 mile..... points = 0 <input type="checkbox"/> 	3
	<p>H 2 TOTAL Score – opportunity for providing habitat <i>Add the scores from H2.1, H2.2, H2.3, H2.4</i></p>	7
	<p><i>TOTAL for H 1 from page 8</i></p>	10
◆	<p>Total Score for Habitat Functions <i>Add the points for H 1 and H 2; then record the result on p. 1</i></p>	17

Comments: _____

CATEGORIZATION BASED ON SPECIAL CHARACTERISTICS

Please determine if the wetland meets the attributes described below and circle the appropriate answers and Category.

Wetland Type – Check off any criteria that apply to the wetland. Circle the Category when the appropriate criteria are met.	
SC1	<p>Estuarine wetlands? (see p.86)</p> <p>Does the wetland unit meet the following criteria for Estuarine wetlands?</p> <p><input type="checkbox"/> The dominant water regime is tidal, <input type="checkbox"/> Vegetated, and <input type="checkbox"/> With a salinity greater than 0.5 ppt.</p> <p style="text-align: center;"><input type="checkbox"/> YES = Go to SC 1.1 <input checked="" type="checkbox"/> NO</p>
	<p>SC 1.1 Is the wetland unit within a National Wildlife Refuge, National Park, National Estuary Reserve, Natural Area Preserve, State Park or Educational, Environmental, or Scientific Reserve designated under WAC 332-30-151? <input type="checkbox"/> YES = Category I <input type="checkbox"/> NO = go to SC 1.2</p>
	<p>SC 1.2 Is the wetland at least 1 acre in size and meets at least two of the following conditions?</p> <p style="text-align: center;"><input type="checkbox"/> YES = Category I <input type="checkbox"/> NO = Category II</p> <p><input type="checkbox"/> The wetland is relatively undisturbed (has no diking, ditching, filling, cultivation, grazing, and has less than 10% cover of non-native plant species. If the non-native <i>Spartina</i> spp. are only species that cover more than 10% of the wetland, then the wetland should be given a dual rating (I/II). The area of <i>Spartina</i> would be rated a Category II while the relatively undisturbed upper marsh with native species would be a Category I. Do not, however, exclude the area of <i>Spartina</i> in determining the size threshold of 1 acre.</p> <p><input type="checkbox"/> At least 3/4 of the landward edge of the wetland has a 100 ft. buffer of shrub, forest, or un-grazed or un-mowed grassland</p> <p><input type="checkbox"/> The wetland has at least 2 of the following features: tidal channels, depressions with open water, or contiguous freshwater wetlands.</p>
SC2	<p>Natural Heritage Wetlands (see p. 87)</p> <p>Natural Heritage wetlands have been identified by the Washington Natural Heritage Program/DNR as either high quality undisturbed wetlands or wetlands that support state Threatened, Endangered, or Sensitive plant species.</p> <p>SC 2.1 Is the wetland being rated in a Section/Township/Range that contains a natural heritage wetland? (This question is used to screen out most sites before you need to contact WNHP/DNR.)</p> <p style="text-align: center;"><input type="checkbox"/> S/T/R information from Appendix D <input type="checkbox"/> or accessed from WNHP/DNR web site <input type="checkbox"/> YES Contact WNHP/DNR (see p. 79) and go to SC 2.2 <input checked="" type="checkbox"/> NO</p> <p>SC 2.2 Has DNR identified the wetland as a high quality undisturbed wetland or as a site with state threatened or endangered plant species?</p> <p style="text-align: center;"><input type="checkbox"/> YES = Category 1 <input checked="" type="checkbox"/> NO not a Heritage Wetland</p>
SC3	<p>Bogs (see p. 87)</p> <p>Does the wetland (or any part of the unit) meet both the criteria for soils and vegetation in bogs? Use the key below to identify if the wetland is a bog. If you answer yes you will still need to rate the wetland based on its function.</p> <ol style="list-style-type: none"> Does the unit have organic soil horizons (i.e. layers of organic soil), either peats or mucks, that compose 16 inches or more of the first 32 inches of soil profile? (See Appendix B for a field key to identify organic soils)? <input type="checkbox"/> YES = go to question 3 <input checked="" type="checkbox"/> NO = go to question 2 Does the wetland have organic soils, either peats or mucks that are less than 16 inches deep over bedrock, or an impermeable hardpan such as clay or volcanic ash, or that are floating on a lake or pond? <input type="checkbox"/> YES = go to question 3 <input checked="" type="checkbox"/> NO = is not a bog for purpose of rating Does the unit have more than 70% cover of mosses at ground level, AND other plants, if present, consist of the “bog” species listed in Table 3 as a significant component of the vegetation (more than 30% of the total shrub and herbaceous cover consists of species in Table 3)? <p style="text-align: center;"><input type="checkbox"/> YES = Is a bog for purpose of rating <input checked="" type="checkbox"/> NO = go to question 4</p> <p>NOTE: If you are uncertain about the extent of mosses in the understory you may substitute that criterion by measuring the pH of the water that seeps into a hole dug at least 16” deep. If the pH is less than 5.0 and the “bog” plant species in Table 3 are present, the wetland is a bog.</p> <ol style="list-style-type: none"> Is the unit forested (> 30% cover) with sitka spruce, subalpine fir, western red cedar, western hemlock, lodgepole pine, quaking aspen, Englemann’s spruce, or western white pine. WITH any of the species (or combination of species) on the bog species plant list in Table 3 as a significant component of the ground cover (> 30% coverage of the total shrub/herbaceous cover)? <p style="text-align: center;"><input type="checkbox"/> YES = Category I <input checked="" type="checkbox"/> NO = Is not a bog for purpose of rating</p>
	<p>Cat. I <input type="checkbox"/></p> <p>Cat. II <input type="checkbox"/></p> <p>Dual Rating I/II <input type="checkbox"/></p> <p>Cat I <input type="checkbox"/></p> <p>Cat. I <input type="checkbox"/></p>

SC4	<p>Forested Wetlands (see p. 90)</p> <p>Does the wetland have at least 1 acre of forest that meet one of these criteria for the Department of Fish and Wildlife’s forests as priority habitats? <i>If you answer yes you will still need to rate the wetland based on its function.</i></p> <p><input type="checkbox"/> Old-growth forests: (west of Cascade Crest) Stands of at least two three species forming a multi-layered canopy with occasional small openings; with at least 8 trees/acre (20 trees/hectare) that are at least 200 years of age OR have a diameter at breast height (dbh) of 32 inches (81 cm or more). NOTE: The criterion for dbh is based on measurements for upland forests. Two-hundred year old trees in wetlands will often have a smaller dbh because their growth rates are often slower. The DFW criterion is and “OR” so old-growth forests do not necessarily have to have trees of this diameter.</p> <p><input type="checkbox"/> Mature forests: (west of the Cascade Crest) Stands where the largest trees are 80 – 200 years old OR have an average diameters (dbh) exceeding 21 inches (53 cm); crown cover may be less than 100%; decay, decadence, numbers of snags, and quantity of large downed material is generally less than that found in old-growth.</p> <p><input type="checkbox"/> YES = Category I <input checked="" type="checkbox"/> NO = not a forested wetland with special characteristics</p>	<p>Cat. I <input type="checkbox"/></p>
SC5	<p>Wetlands in Coastal Lagoons (see p. 91)</p> <p>Does the wetland meet all of the following criteria of a wetland in a coastal lagoon?</p> <p><input type="checkbox"/> The wetland lies in a depression adjacent to marine waters that is wholly or partially separated from marine waters by sandbanks, gravel banks, shingle, or, less frequently, rocks.</p> <p><input type="checkbox"/> The lagoon in which the wetland is located contains surface water that is saline or brackish (> 0.5 ppt) during most of the year in at least a portion of the lagoon (<i>needs to be measured near the bottom.</i>)</p> <p><input type="checkbox"/> YES = Go to SC 5.1 <input checked="" type="checkbox"/> NO not a wetland in a coastal lagoon</p> <p>SC 5.1 Does the wetland meet all of the following three conditions?</p> <p><input type="checkbox"/> The wetland is relatively undisturbed (has no diking, ditching, filling, cultivation, grazing) and has less than 20% cover of invasive plant species (see list of invasive species on p. 74).</p> <p><input type="checkbox"/> At least 3/4 of the landward edge of the wetland has a 100 ft. buffer of shrub, forest, or un-grazed or un-mowed grassland.</p> <p><input type="checkbox"/> The wetland is larger than 1/10 acre (4350 square ft.)</p> <p><input type="checkbox"/> YES = Category I <input type="checkbox"/> NO = Category II</p>	<p style="background-color: #cccccc;"> </p> <p>Cat. I <input type="checkbox"/></p> <p>Cat. II <input type="checkbox"/></p>
SC6	<p>Interdunal Wetlands (see p. 93)</p> <p>Is the wetland west of the 1889 line (also called the Western Boundary of Upland Ownership or WBUO)?</p> <p><input type="checkbox"/> YES = Go to SC 6.1 <input checked="" type="checkbox"/> NO not an interdunal wetland for rating</p> <p><i>If you answer yes you will still need to rate the wetland based on its functions.</i></p> <p>In practical terms that means the following geographic areas:</p> <ul style="list-style-type: none"> • Long Beach Peninsula -- lands west of SR 103 • Grayland-Westport -- lands west of SR 105 • Ocean Shores-Copalis – lands west of SR 115 and SR 109 <p>SC 6.1 Is the wetland one acre or larger, or is it in a mosaic of wetlands that is one acre or larger?</p> <p><input type="checkbox"/> YES = Category II <input type="checkbox"/> NO = go to SC 6.2</p> <p>SC 6.2 Is the wetland between 0.1 and 1 acre, or is it in a mosaic of wetlands that is between 0.1 and 1 acre?</p> <p><input type="checkbox"/> YES = Category III</p>	<p>Cat. II <input type="checkbox"/></p> <p>Cat. III <input type="checkbox"/></p>
◆	<p>Category of wetland based on Special Characteristics</p> <p><i>Choose the “highest” rating if wetland falls into several categories, and record on p. 1.</i></p> <p>If you answered NO for all types enter “Not Applicable” on p. 1</p>	<p>NA</p>

Comments:

APPENDIX D

RESOURCE MAPS

Resource Map Index

Resource	Frame Number	Hydrogeomorphic Classifications	Hydrogeomorphic Classification Used for Rating	State Rating (Ecology)
Wetlands				
Mercer Slough	2, 3, 4	Depressional, Lake-Fringe, Riverine, Slope	Depressional	II
Alcove Creek	5	Depressional, Riverine	Depressional	II
Bellefield South	5	Riverine, Slope	Riverine	II
Bellefield North	5	Riverine, Slope	Riverine	II
8th Street	5	Depressional	Depressional	III
Lake Bellevue	9	Depressional	Depressional	III
South Lake	9	Depressional	Depressional	III
Central Lake	9	Depressional	Depressional	III
North Lake	9	Slope	Slope	IV
BNSF Southwest	10	Depressional, Slope	Depressional	III
BNSF East	10	Depressional	Depressional	III
BNSF West	10	Depressional, Slope	Depressional	III
BNSF Northeast	10	Depressional	Depressional	III
BNSF Northwest	10	Depressional, Slope	Depressional	IV
BNSF North	10	Depressional, Slope	Depressional	III
Kelsey West Tributary Pond	11	Depressional, Riverine	Depressional	II
Kelsey West Tributary Stream	11	Riverine	Riverine	III
136th Place	13	Depressional	Depressional	III
SR 520 West	13	Depressional, Slope	Depressional	III
Valley Creek	13	Riverine, Slope	Riverine	II
SR 520 East	13, 14	Slope	Slope	III
Streams				
Stream A	4	NA	NA	NA
Stream B	4	NA	NA	NA
Wye Creek	4	NA	NA	NA
Alcove Creek	5	NA	NA	NA

Resource	Frame Number	Hydrogeomorphic Classifications	Hydrogeomorphic Classification Used for Rating	State Rating (Ecology)
Sturtevant Creek	9	NA	NA	NA
West Tributary to Kelsey Creek	11	NA	NA	NA
Stream C	11, 12	NA	NA	NA
Goff Creek	12	NA	NA	NA
Unnamed Tributary to Kelsey Creek	13	NA	NA	NA
Valley Creek	13	NA	NA	NA
Jurisdictional Ditches				
JD-1	10	NA	NA	NA
JD-2	10	NA	NA	NA
JD-3	10	NA	NA	NA
JD-4	12, 13	NA	NA	NA
JD-6	13	NA	NA	NA
JD-7	13	NA	NA	NA
JD-8	13	NA	NA	NA

Notes:

Frames within the City of Redmond (Frames 15 and 16) were not included because no resources were identified in that jurisdiction.

NA = not applicable

\orcas\gis\Jobs\120975-01.01_Sound_Transit_East_Link_Env_Support\Maps\2014_08\Appendix D Wetlands Maps August 27 2014 Draft.mxd eiverson 8/28/2014 11:20:29 AM



Appendix D

Wetland/Stream/Ditch Locations

Sound Transit East Link

Extension Project

Frame 1

- LEGEND**
- Stream Location¹
 - Stream Location²
 - Jurisdictional Ditch Location¹
 - Culvert Location²
 - Culvert Location (Estimated)³
 - Mercer Slough Flow Direction
 - Stream or Ditch Flow Direction
 - Stream Buffers⁴
 - Wetland Location¹
 - Non-delineated Wetland Areas⁵
 - Wetland Area Buffers⁴
 - Wetlands Sample Plot
 - Uplands Sample Plot
 - Water Bodies (King County)
 - Tax Parcels (King County)
 - Proposed Light Rail Alignment

- NOTES:**
1. Locations determined from field survey activities carried out by Anchor QEA, LLC, in 2013.
 2. City of Bellevue stream data.
 3. City of Bellevue data does not include culvert information for this stream.
 4. Wetland buffers and stream buffers have been modified to not extend over impervious areas or structures. Wetland and stream buffers may overlap in some areas.
 5. Non-delineated areas were approximated using available aerial imagery and were not accessible due to a lack of access or agreed right-of-entry.
 6. King County water body data were modified by Anchor QEA where necessary to match field-delineated ordinary high water mark (OHWM).

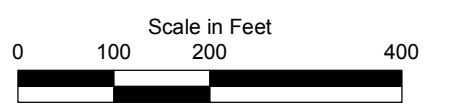

















V:\cas\jobs\120975-01\01_Sound_Transit_East_Link_Env_Support\Maps\2014_08\Appendix D Wetlands Maps August 27 2014 Draft.mxd eiverson 8/26/2014 11:20:33 AM



Appendix D Wetland/Stream/Ditch Locations Sound Transit East Link Extension Project Frame 2

LEGEND

-  Stream Location¹
-  Stream Location²
-  Jurisdictional Ditch Location¹
-  Culvert Location²
-  Culvert Location (Estimated)³
-  Mercer Slough Flow Direction
-  Stream or Ditch Flow Direction
-  Stream Buffers⁴
-  Wetland Location¹
-  Non-delineated Wetland Areas⁵
-  Wetland Area Buffers⁴
-  Wetlands Sample Plot
-  Uplands Sample Plot
-  Water Bodies (King County)
-  Tax Parcels (King County)
-  Proposed Light Rail Alignment





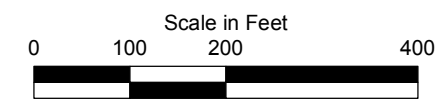











NOTES:

1. Locations determined from field survey activities carried out by Anchor QEA, LLC, in 2013.
2. City of Bellevue stream data.
3. City of Bellevue data does not include culvert information for this stream.
4. Wetland buffers and stream buffers have been modified to not extend over impervious areas or structures. Wetland and stream buffers may overlap in some areas.
5. Non-delineated areas were approximated using available aerial imagery and were not accessible due to a lack of access or agreed right-of-entry.
6. King County water body data were modified by Anchor QEA where necessary to match field-delineated ordinary high water mark (OHWM).



Appendix D
Wetland/Stream/Ditch Locations
Sound Transit East Link
Extension Project
Frame 3

LEGEND

-  Stream Location¹
-  Stream Location²
-  Jurisdictional Ditch Location¹
-  Culvert Location²
-  Culvert Location (Estimated)³
-  Mercer Slough Flow Direction
-  Stream or Ditch Flow Direction
-  Stream Buffers⁴
-  Wetland Location¹
-  Non-delineated Wetland Areas⁵
-  Wetland Area Buffers⁴
-  Wetlands Sample Plot
-  Uplands Sample Plot
-  Water Bodies (King County)
-  Tax Parcels (King County)
-  Proposed Light Rail Alignment





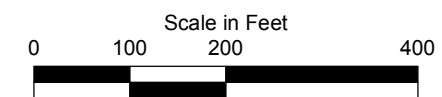









NOTES:

1. Locations determined from field survey activities carried out by Anchor QEA, LLC, in 2013.
2. City of Bellevue stream data.
3. City of Bellevue data does not include culvert information for this stream.
4. Wetland buffers and stream buffers have been modified to not extend over impervious areas or structures. Wetland and stream buffers may overlap in some areas.
5. Non-delineated areas were approximated using available aerial imagery and were not accessible due to a lack of access or agreed right-of-entry.
6. King County water body data were modified by Anchor QEA where necessary to match field-delineated ordinary high water mark (OHWM).



Appendix D
Wetland/Stream/Ditch Locations
Sound Transit East Link
Extension Project
Frame 4

LEGEND

-  Stream Location¹
-  Stream Location²
-  Jurisdictional Ditch Location¹
-  Culvert Location²
-  Culvert Location (Estimated)³
-  Mercer Slough Flow Direction
-  Stream or Ditch Flow Direction
-  Stream Buffers⁴
-  Wetland Location¹
-  Non-delineated Wetland Areas⁵
-  Wetland Area Buffers⁴
-  Wetlands Sample Plot
-  Uplands Sample Plot
-  Water Bodies (King County)
-  Tax Parcels (King County)
-  Proposed Light Rail Alignment

NOTES:

1. Locations determined from field survey activities carried out by Anchor QEA, LLC, in 2013.
2. City of Bellevue stream data.
3. City of Bellevue data does not include culvert information for this stream.
4. Wetland buffers and stream buffers have been modified to not extend over impervious areas or structures. Wetland and stream buffers may overlap in some areas.
5. Non-delineated areas were approximated using available aerial imagery and were not accessible due to a lack of access or agreed right-of-entry.
6. King County water body data were modified by Anchor QEA where necessary to match field-delineated ordinary high water mark (OHWM).

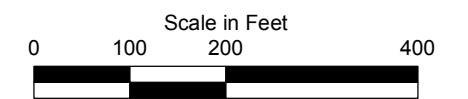

















\\orca\gis\Jobs\120975-01\01_Sound_Transit_East_Link_Support\Maps\2014_08\Appendix D Wetlands Maps August 27 2014 Draft.mxd everson 8/26/2014 11:20:43 AM



Appendix D Wetland/Stream/Ditch Locations Sound Transit East Link Extension Project Frame 5

LEGEND

-  Stream Location¹
-  Stream Location²
-  Jurisdictional Ditch Location¹
-  Culvert Location²
-  Culvert Location (Estimated)³
-  Mercer Slough Flow Direction
-  Stream or Ditch Flow Direction
-  Stream Buffers⁴
-  Wetland Location¹
-  Non-delineated Wetland Areas⁵
-  Wetland Area Buffers⁴
-  Wetlands Sample Plot
-  Uplands Sample Plot
-  Water Bodies (King County)
-  Tax Parcels (King County)
-  Proposed Light Rail Alignment

NOTES:

1. Locations determined from field survey activities carried out by Anchor QEA, LLC, in 2013.
2. City of Bellevue stream data.
3. City of Bellevue data does not include culvert information for this stream.
4. Wetland buffers and stream buffers have been modified to not extend over impervious areas or structures. Wetland and stream buffers may overlap in some areas.
5. Non-delineated areas were approximated using available aerial imagery and were not accessible due to a lack of access or agreed right-of-entry.
6. King County water body data were modified by Anchor QEA where necessary to match field-delineated ordinary high water mark (OHWM).

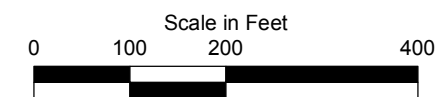



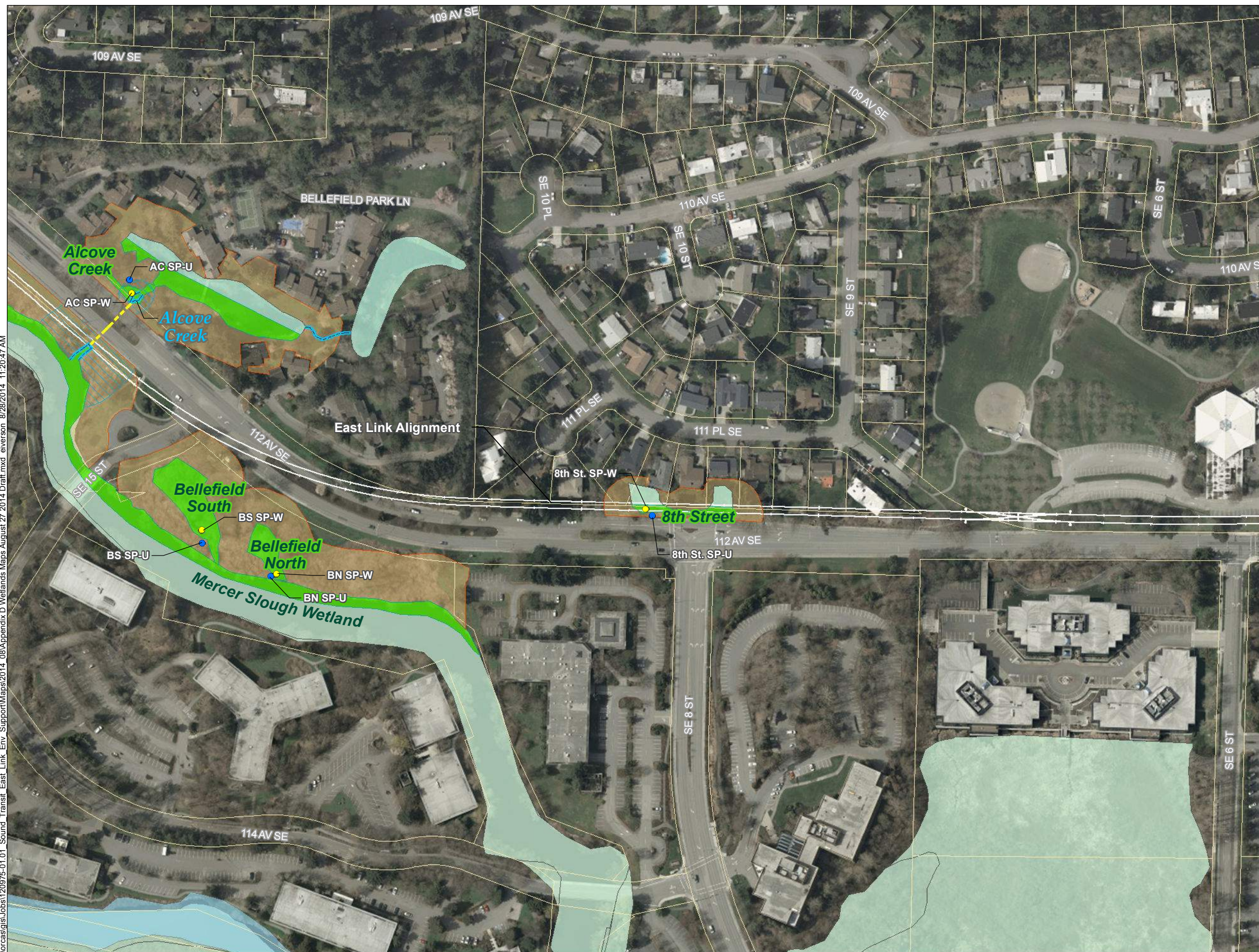













V:\cas\gis\Jobs\120975-01\01_Sound_Transit_East_Link_Support\Maps\2014_08\Appendix D Wetlands Maps August 27 2014 Draft.mxd eiverson 8/28/2014 11:20:47 AM



Appendix D
Wetland/Stream/Ditch Locations
Sound Transit East Link
Extension Project
Frame 6

LEGEND

-  Stream Location¹
-  Stream Location²
-  Jurisdictional Ditch Location¹
-  Culvert Location²
-  Culvert Location (Estimated)³
-  Mercer Slough Flow Direction
-  Stream or Ditch Flow Direction
-  Stream Buffers⁴
-  Wetland Location¹
-  Non-delineated Wetland Areas⁵
-  Wetland Area Buffers⁴
-  Wetlands Sample Plot
-  Uplands Sample Plot
-  Water Bodies (King County)
-  Tax Parcels (King County)
-  Proposed Light Rail Alignment

NOTES:

1. Locations determined from field survey activities carried out by Anchor QEA, LLC, in 2013.
2. City of Bellevue stream data.
3. City of Bellevue data does not include culvert information for this stream.
4. Wetland buffers and stream buffers have been modified to not extend over impervious areas or structures. Wetland and stream buffers may overlap in some areas.
5. Non-delineated areas were approximated using available aerial imagery and were not accessible due to a lack of access or agreed right-of-entry.
6. King County water body data were modified by Anchor QEA where necessary to match field-delineated ordinary high water mark (OHWM).

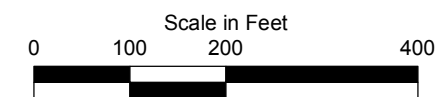



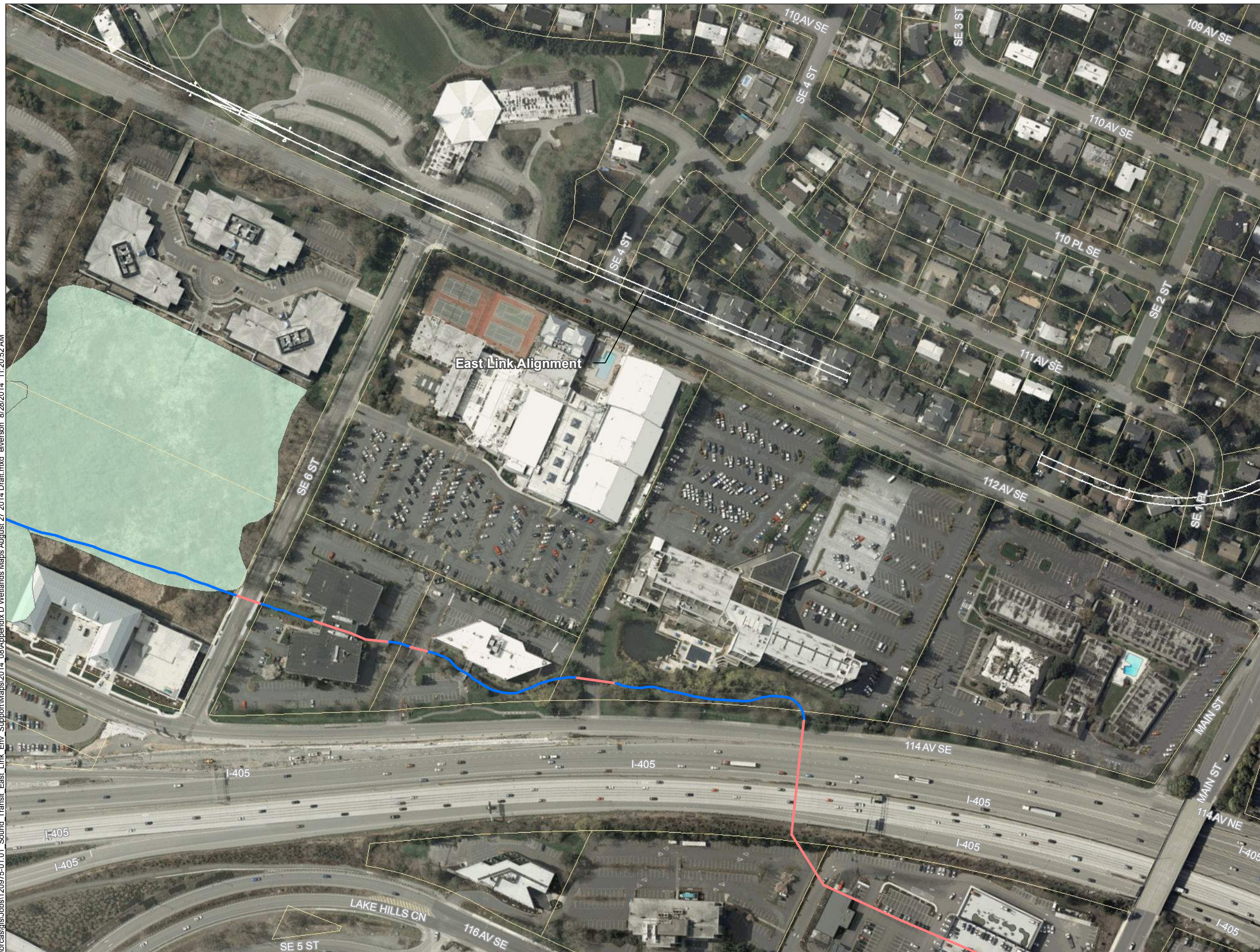













V:\cas\jobs\120975-01.01 Sound Transit East Link Env Support\Maps\2014_08\Appendix D Wetlands Maps August 27 2014 Draft.mxd eiverson 8/28/2014 11:20:52 AM



Appendix D Wetland/Stream/Ditch Locations Sound Transit East Link Extension Project Frame 7

LEGEND

-  Stream Location¹
-  Stream Location²
-  Jurisdictional Ditch Location¹
-  Culvert Location²
-  Culvert Location (Estimated)³
-  Mercer Slough Flow Direction
-  Stream or Ditch Flow Direction
-  Stream Buffers⁴
-  Wetland Location¹
-  Non-delineated Wetland Areas⁵
-  Wetland Area Buffers⁴
-  Wetlands Sample Plot
-  Uplands Sample Plot
-  Water Bodies (King County)
-  Tax Parcels (King County)
-  Proposed Light Rail Alignment





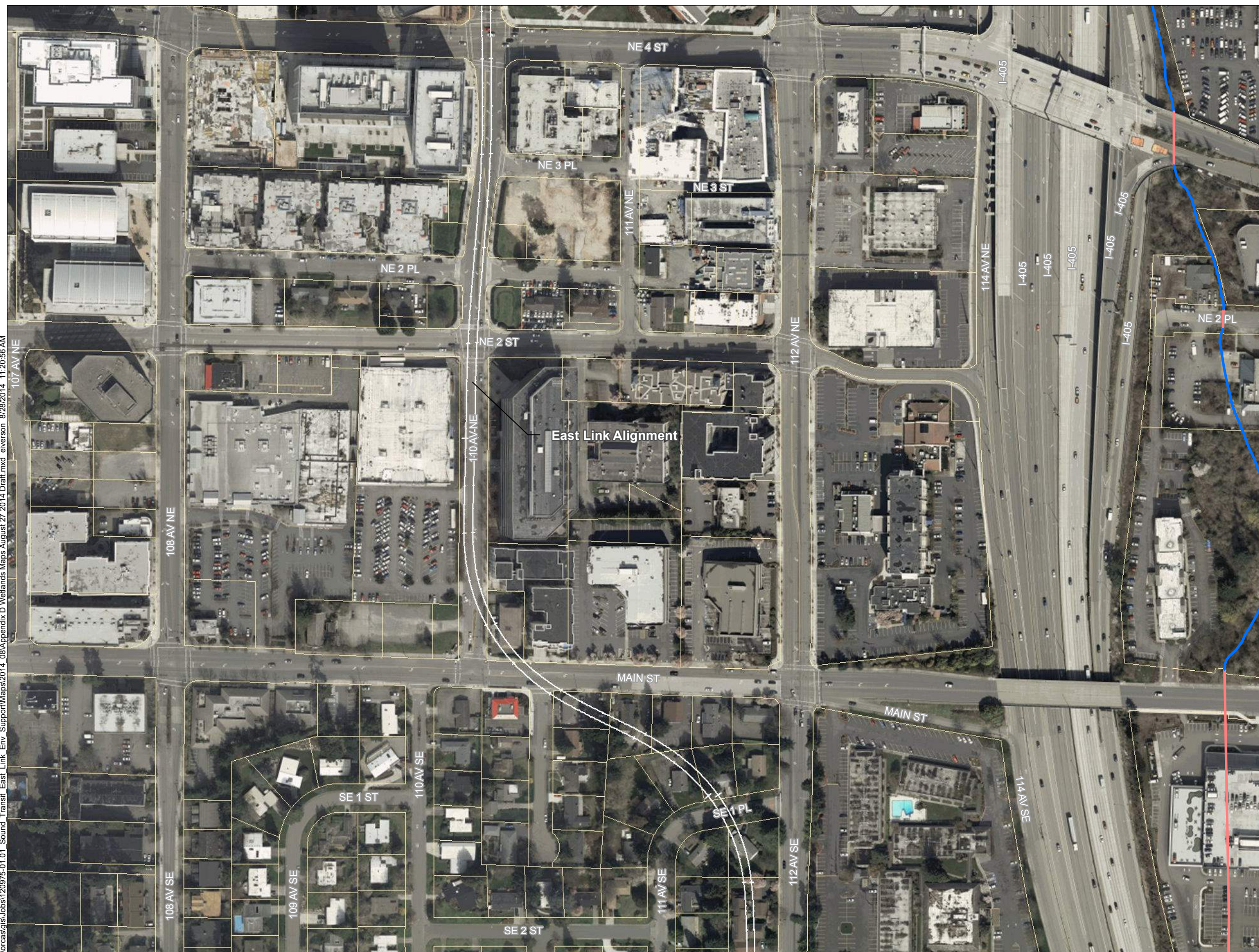
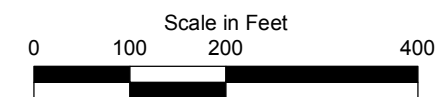









NOTES:

1. Locations determined from field survey activities carried out by Anchor QEA, LLC, in 2013.
2. City of Bellevue stream data.
3. City of Bellevue data does not include culvert information for this stream.
4. Wetland buffers and stream buffers have been modified to not extend over impervious areas or structures. Wetland and stream buffers may overlap in some areas.
5. Non-delineated areas were approximated using available aerial imagery and were not accessible due to a lack of access or agreed right-of-entry.
6. King County water body data were modified by Anchor QEA where necessary to match field-delineated ordinary high water mark (OHWM).



Appendix D
Wetland/Stream/Ditch Locations
Sound Transit East Link
Extension Project
Frame 8

LEGEND

-  Stream Location¹
-  Stream Location²
-  Jurisdictional Ditch Location¹
-  Culvert Location²
-  Culvert Location (Estimated)³
-  Mercer Slough Flow Direction
-  Stream or Ditch Flow Direction
-  Stream Buffers⁴
-  Wetland Location¹
-  Non-delineated Wetland Areas⁵
-  Wetland Area Buffers⁴
-  Wetlands Sample Plot
-  Uplands Sample Plot
-  Water Bodies (King County)
-  Tax Parcels (King County)
-  Proposed Light Rail Alignment

NOTES:

1. Locations determined from field survey activities carried out by Anchor QEA, LLC, in 2013.
2. City of Bellevue stream data.
3. City of Bellevue data does not include culvert information for this stream.
4. Wetland buffers and stream buffers have been modified to not extend over impervious areas or structures. Wetland and stream buffers may overlap in some areas.
5. Non-delineated areas were approximated using available aerial imagery and were not accessible due to a lack of access or agreed right-of-entry.
6. King County water body data were modified by Anchor QEA where necessary to match field-delineated ordinary high water mark (OHWM).

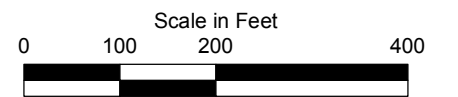

I:\projects\2014\201408\20140808\Appendix D Wetlands Maps August 27 2014 Draft.mxd eiverson 8/28/2014 11:20:59 AM

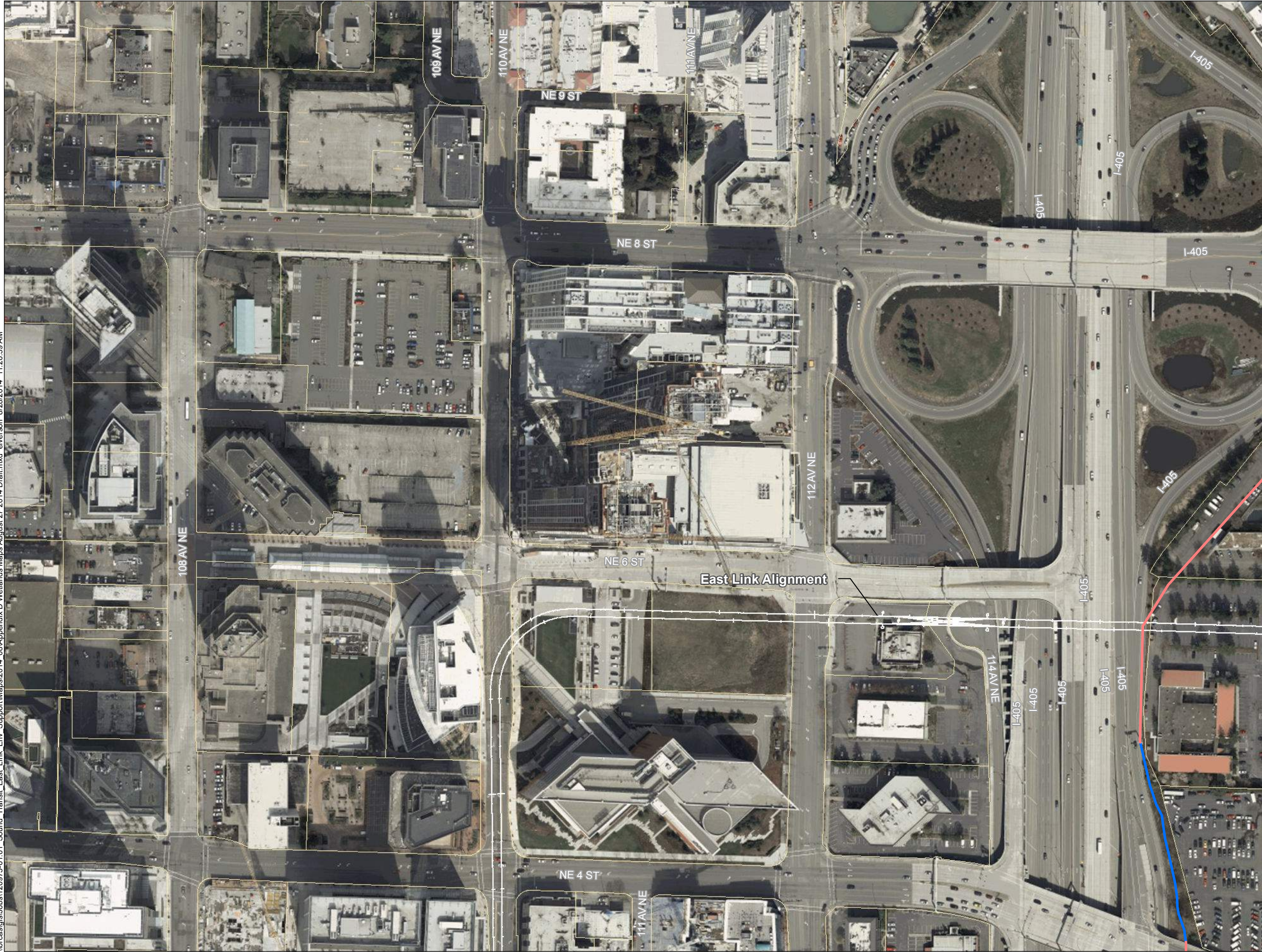

Appendix D
Wetland/Stream/Ditch Locations
Sound Transit East Link
Extension Project
Frame 9

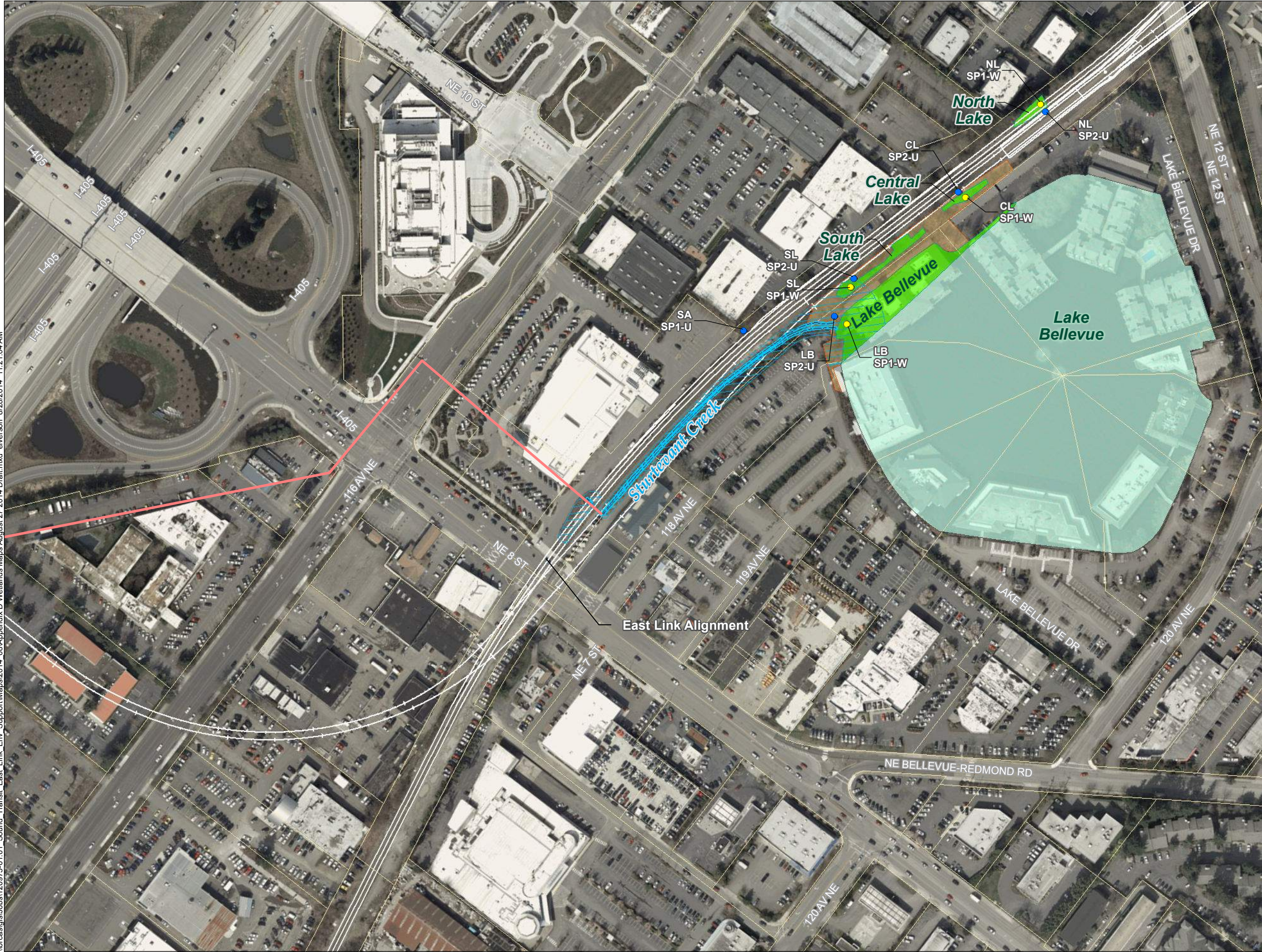

LEGEND

- Stream Location¹
- Stream Location²
- Jurisdictional Ditch Location¹
- Culvert Location²
- Culvert Location (Estimated)³
- Mercer Slough Flow Direction
- Stream or Ditch Flow Direction
- Stream Buffers⁴
- Wetland Location¹
- Non-delineated Wetland Areas⁵
- Wetland Area Buffers⁴
- Wetlands Sample Plot
- Uplands Sample Plot
- Water Bodies (King County)
- Tax Parcels (King County)
- Proposed Light Rail Alignment



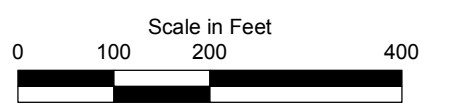













- NOTES:**
1. Locations determined from field survey activities carried out by Anchor QEA, LLC, in 2013.
 2. City of Bellevue stream data.
 3. City of Bellevue data does not include culvert information for this stream.
 4. Wetland buffers and stream buffers have been modified to not extend over impervious areas or structures. Wetland and stream buffers may overlap in some areas.
 5. Non-delineated areas were approximated using available aerial imagery and were not accessible due to a lack of access or agreed right-of-entry.
 6. King County water body data were modified by Anchor QEA where necessary to match field-delineated ordinary high water mark (OHWM).



\orcass\gis\120975-01\01_Sound_Transit_East_Link_Env_Support\Maps\2014_08\Appendix D Wetlands Maps August 27 2014 Draft.mxd eiverson 8/28/2014 11:21:04 AM

Appendix D
Wetland/Stream/Ditch Locations
Sound Transit East Link
Extension Project
Frame 10

LEGEND

-  Stream Location¹
-  Stream Location²
-  Jurisdictional Ditch Location¹
-  Culvert Location²
-  Culvert Location (Estimated)³
-  Mercer Slough Flow Direction
-  Stream or Ditch Flow Direction
-  Stream Buffers⁴
-  Wetland Location¹
-  Non-delineated Wetland Areas⁵
-  Wetland Area Buffers⁴
-  Wetlands Sample Plot
-  Uplands Sample Plot
-  Water Bodies (King County)
-  Tax Parcels (King County)
-  Proposed Light Rail Alignment

NOTES:

1. Locations determined from field survey activities carried out by Anchor QEA, LLC, in 2013.
2. City of Bellevue stream data.
3. City of Bellevue data does not include culvert information for this stream.
4. Wetland buffers and stream buffers have been modified to not extend over impervious areas or structures. Wetland and stream buffers may overlap in some areas.
5. Non-delineated areas were approximated using available aerial imagery and were not accessible due to a lack of access or agreed right-of-entry.
6. King County water body data were modified by Anchor QEA where necessary to match field-delineated ordinary high water mark (OHWM).

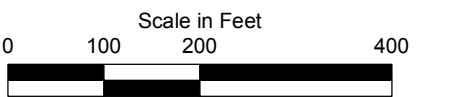

















\orcass\gis\Jobs\120975-01.01_Sound_Transit_East_Link_Support\Maps\2014_08\Appendix D Wetlands Maps August 27 2014 Draft.mxd eiverson 8/28/2014 11:21:08 AM



Appendix D
Wetland/Stream/Ditch Locations
Sound Transit East Link
Extension Project
Frame 11

LEGEND

-  Stream Location¹
-  Stream Location²
-  Jurisdictional Ditch Location¹
-  Culvert Location²
-  Culvert Location (Estimated)³
-  Mercer Slough Flow Direction
-  Stream or Ditch Flow Direction
-  Stream Buffers⁴
-  Wetland Location¹
-  Non-delineated Wetland Areas⁵
-  Wetland Area Buffers⁴
-  Wetlands Sample Plot
-  Uplands Sample Plot
-  Water Bodies (King County)
-  Tax Parcels (King County)
-  Proposed Light Rail Alignment





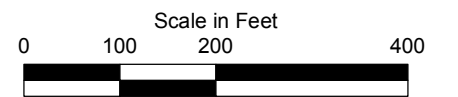









NOTES:

1. Locations determined from field survey activities carried out by Anchor QEA, LLC, in 2013.
2. City of Bellevue stream data.
3. City of Bellevue data does not include culvert information for this stream.
4. Wetland buffers and stream buffers have been modified to not extend over impervious areas or structures. Wetland and stream buffers may overlap in some areas.
5. Non-delineated areas were approximated using available aerial imagery and were not accessible due to a lack of access or agreed right-of-entry.
6. King County water body data were modified by Anchor QEA where necessary to match field-delineated ordinary high water mark (OHWM).



Appendix D
Wetland/Stream/Ditch Locations
Sound Transit East Link
Extension Project
Frame 12

LEGEND

-  Stream Location¹
-  Stream Location²
-  Jurisdictional Ditch Location¹
-  Culvert Location²
-  Culvert Location (Estimated)³
-  Mercer Slough Flow Direction
-  Stream or Ditch Flow Direction
-  Stream Buffers⁴
-  Wetland Location¹
-  Non-delineated Wetland Areas⁵
-  Wetland Area Buffers⁴
-  Wetlands Sample Plot
-  Uplands Sample Plot
-  Water Bodies (King County)
-  Tax Parcels (King County)
-  Proposed Light Rail Alignment

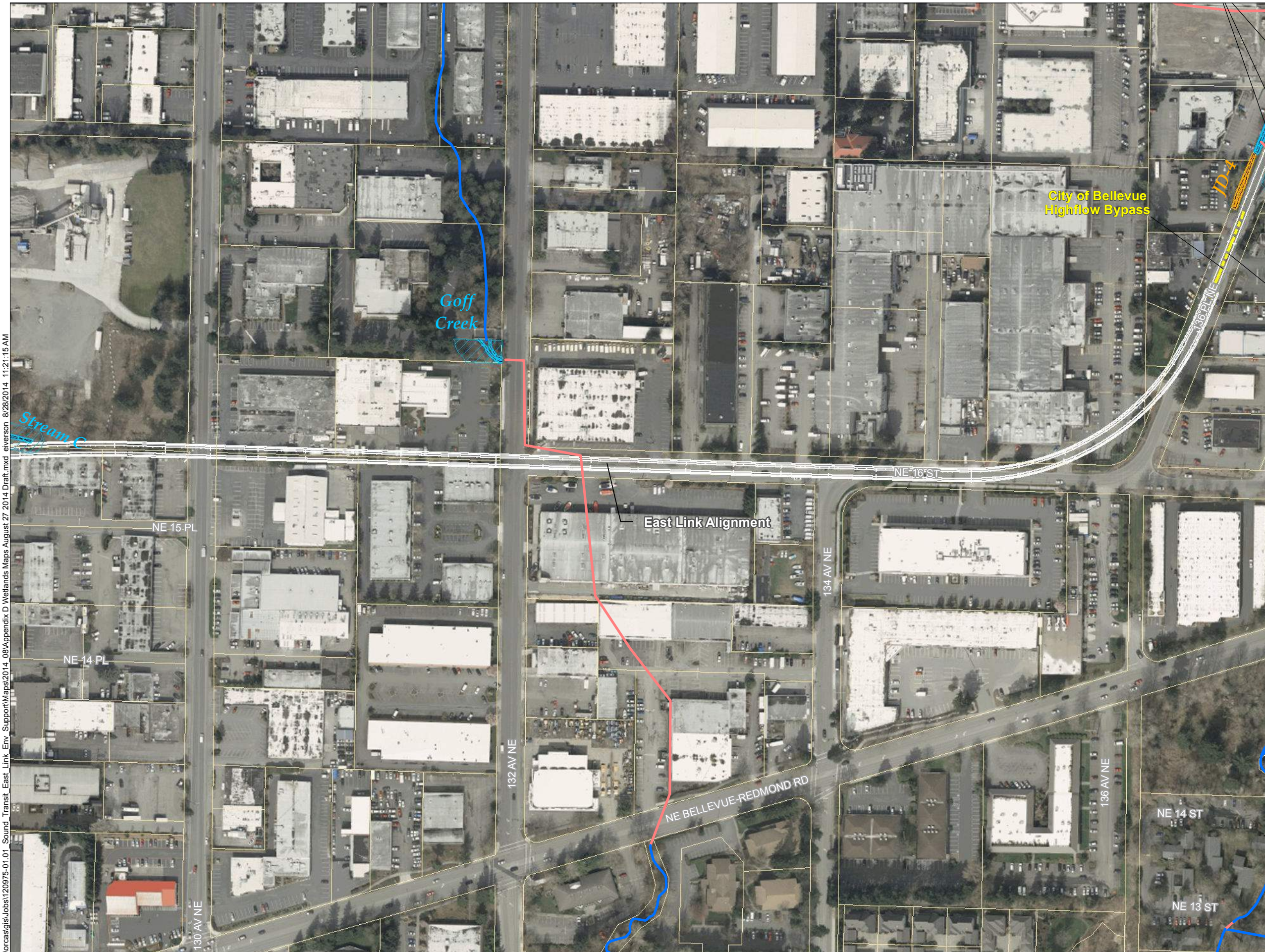
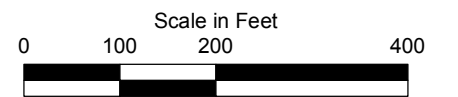

NOTES:

1. Locations determined from field survey activities carried out by Anchor QEA, LLC, in 2013.
2. City of Bellevue stream data.
3. City of Bellevue data does not include culvert information for this stream.
4. Wetland buffers and stream buffers have been modified to not extend over impervious areas or structures. Wetland and stream buffers may overlap in some areas.
5. Non-delineated areas were approximated using available aerial imagery and were not accessible due to a lack of access or agreed right-of-entry.
6. King County water body data were modified by Anchor QEA where necessary to match field-delineated ordinary high water mark (OHWM).



Appendix D
Wetland/Stream/Ditch Locations
Sound Transit East Link
Extension Project
Frame 13

LEGEND

-  Stream Location¹
-  Stream Location²
-  Jurisdictional Ditch Location¹
-  Culvert Location²
-  Culvert Location (Estimated)³
-  Mercer Slough Flow Direction
-  Stream or Ditch Flow Direction
-  Stream Buffers⁴
-  Wetland Location¹
-  Non-delineated Wetland Areas⁵
-  Wetland Area Buffers⁴
-  Wetlands Sample Plot
-  Uplands Sample Plot
-  Water Bodies (King County)
-  Tax Parcels (King County)
-  Proposed Light Rail Alignment

NOTES:



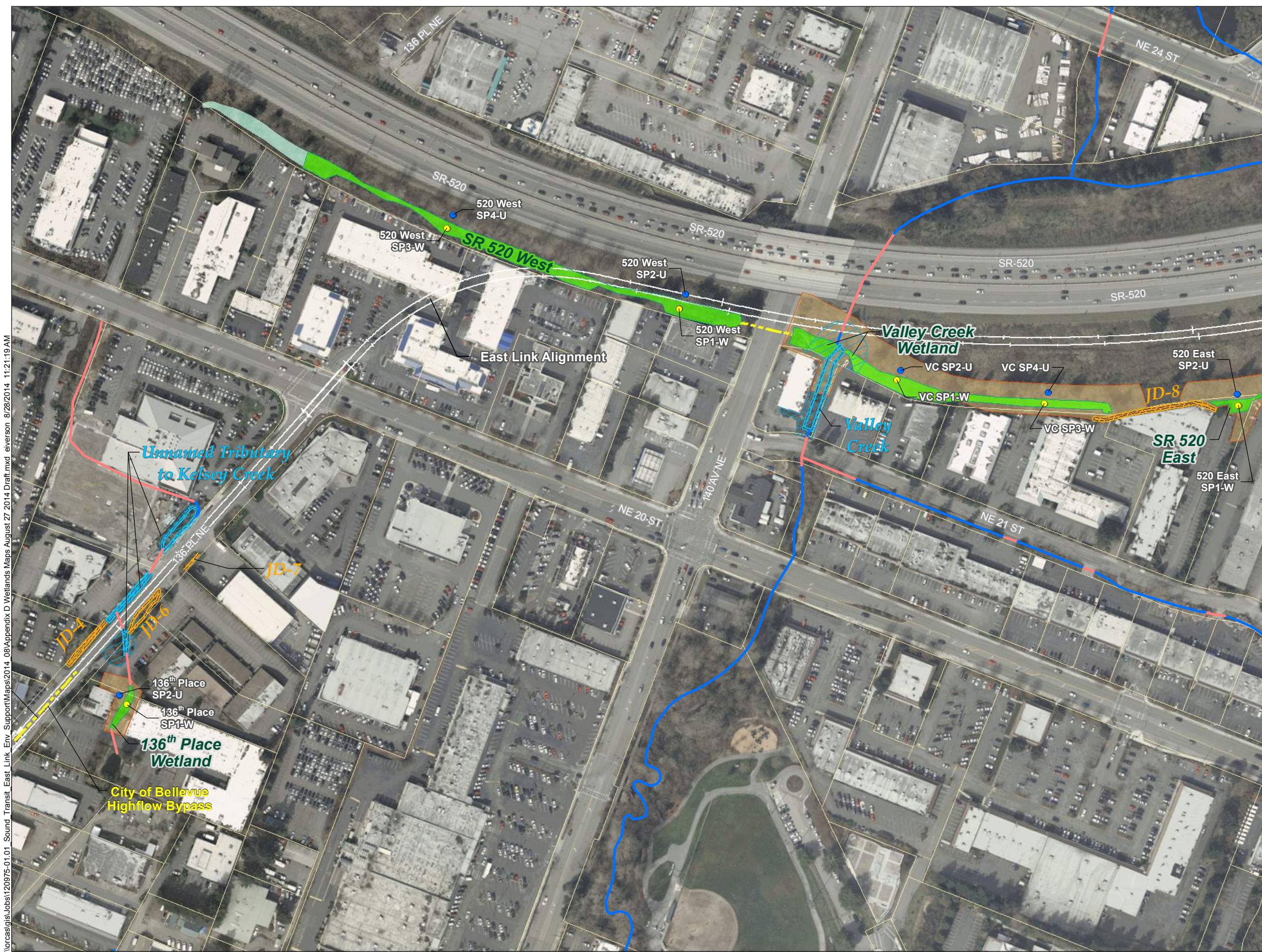
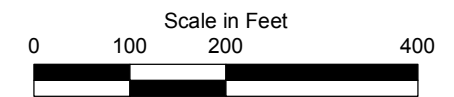













1. Locations determined from field survey activities carried out by Anchor QEA, LLC, in 2013.
2. City of Bellevue stream data.
3. City of Bellevue data does not include culvert information for this stream.
4. Wetland buffers and stream buffers have been modified to not extend over impervious areas or structures. Wetland and stream buffers may overlap in some areas.
5. Non-delineated areas were approximated using available aerial imagery and were not accessible due to a lack of access or agreed right-of-entry.
6. King County water body data were modified by Anchor QEA where necessary to match field-delineated ordinary high water mark (OHWM).



\orcasis\jobs\120975-01\01_Sound_Transit_East_Link_Env_Support\Maps\2014_08\Appendix D Wetlands Maps August 27 2014 Draft.mxd everson 8/28/2014 11:21:19 AM

Appendix D
Wetland/Stream/Ditch Locations
Sound Transit East Link
Extension Project
Frame 14

LEGEND

-  Stream Location¹
-  Stream Location²
-  Jurisdictional Ditch Location¹
-  Culvert Location²
-  Culvert Location (Estimated)³
-  Mercer Slough Flow Direction
-  Stream or Ditch Flow Direction
-  Stream Buffers⁴
-  Wetland Location¹
-  Non-delineated Wetland Areas⁵
-  Wetland Area Buffers⁴
-  Wetlands Sample Plot
-  Uplands Sample Plot
-  Water Bodies (King County)
-  Tax Parcels (King County)
-  Proposed Light Rail Alignment

NOTES:

1. Locations determined from field survey activities carried out by Anchor QEA, LLC, in 2013.
2. City of Bellevue stream data.
3. City of Bellevue data does not include culvert information for this stream.
4. Wetland buffers and stream buffers have been modified to not extend over impervious areas or structures. Wetland and stream buffers may overlap in some areas.
5. Non-delineated areas were approximated using available aerial imagery and were not accessible due to a lack of access or agreed right-of-entry.
6. King County water body data were modified by Anchor QEA where necessary to match field-delineated ordinary high water mark (OHWM).

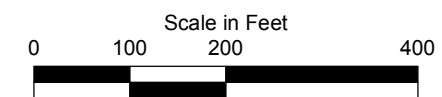

V:\cas\jobs\120975-01\01_Sound_Transit_East_Link_Support\Maps\2014_08\Appendix D Wetlands Maps August 27 2014 Draft.mxd eiverson 8/26/2014 11:21:23 AM



APPENDIX E
JURISDICTIONAL DITCH FIELD DATA
FORMS

DITCH FIELD DATA SHEET

Project <u>Sound Transit East Link Ext.</u>	Date <u>4/23/2013</u>
Applicant <u>Sound Transit</u>	County/State <u>King/WA</u>
Investigators <u>C. Douglas, J. Pursley</u>	S/T/R <u>29/24N/5E</u>

Ditch Name <u>1</u>	Photo <u>Yes</u>
Location <u>BNSF ROW</u>	
Ditch Connects to Navigable Water (jurisdictional under Talent)? <input checked="" type="checkbox"/> yes <input type="checkbox"/> no (explain) <u>West Tributary to Kelsey Creek via culverts</u>	

Field Observations	
Ditch Characteristics	Other Observations
<input checked="" type="checkbox"/> Bed and bank apparent <input checked="" type="checkbox"/> Steeply sloped <input checked="" type="checkbox"/> Vegetation flattened from possible water flow <input checked="" type="checkbox"/> Scour signs <input type="checkbox"/> Debris rack present <input checked="" type="checkbox"/> No vegetation in scour area <input type="checkbox"/> Vegetation with very shallow roots in center <input type="checkbox"/> Vegetation or soil stained with water marks <input type="checkbox"/> Vegetation is thick, deep roots, and no flow marks <input type="checkbox"/> Soil is cracked, or other evidence of ponding (explain) _____ <input checked="" type="checkbox"/> Ditch is flat and/or wide	<input checked="" type="checkbox"/> Discharges into catchbasin or <u>culvert</u> (circle) <input checked="" type="checkbox"/> Standing water present <u>30</u> % of ditch <input type="checkbox"/> Water flowing in ditch during dry season <input checked="" type="checkbox"/> Large quantities of water flowing during wet season, or after rain event <input checked="" type="checkbox"/> Culvert showing water stains or marks <input type="checkbox"/> Soils are hydric <input type="checkbox"/> Soils are native <input checked="" type="checkbox"/> Soils are fill, sand, or clearly indicative of planned/constructed ditch <input type="checkbox"/> Soils are saturated during the dry season <input checked="" type="checkbox"/> If ditch is rock lined, there are water stained rocks to indicate a high water mark or flow line

Other Information
Does site appear to be regularly maintained? <input type="checkbox"/> yes <input checked="" type="checkbox"/> no (explain)
Has site been recently mowed? <input type="checkbox"/> yes <input checked="" type="checkbox"/> no (explain)
Length <u>214'</u> ^{2 to 3'} Width _____ Total Area _____
Ditch with water flowing during site visit <u>60</u> % Ditch with standing water during site visit <u>30</u> %

Notes:

DITCH FIELD DATA SHEET

Project <u>Sound Transit East Link EXT.</u>	Date <u>4/23/2013</u>
Applicant <u>Sound Transit</u>	County/State <u>King/WA</u>
Investigators <u>C. Douglas, J. Purisley</u>	S/T/R <u>29/24N/SE</u>

Ditch Name <u>2</u>	Photo <u>Yes</u>
Location <u>BNSF ROW</u>	
Ditch Connects to Navigable Water (jurisdictional under Talent)? <input checked="" type="checkbox"/> yes <input type="checkbox"/> no (explain) <u>West Tributary to Kelsey Creek via Culvert</u>	

Field Observations	
<p style="text-align: center; margin: 0;">Ditch Characteristics</p> <ul style="list-style-type: none"> <input checked="" type="checkbox"/> Bed and bank apparent <input checked="" type="checkbox"/> Steeply sloped <input checked="" type="checkbox"/> Vegetation flattened from possible water flow <input checked="" type="checkbox"/> Scour signs <input type="checkbox"/> Debris rack present <input type="checkbox"/> No vegetation in scour area <input checked="" type="checkbox"/> Vegetation with very shallow roots in center <input type="checkbox"/> Vegetation or soil stained with water marks <input type="checkbox"/> Vegetation is thick, deep roots, and no flow marks <input type="checkbox"/> Soil is cracked, or other evidence of ponding (explain) _____ <input checked="" type="checkbox"/> Ditch is flat and/or wide 	<p style="text-align: center; margin: 0;">Other Observations</p> <ul style="list-style-type: none"> <input checked="" type="checkbox"/> Discharges into catchbasin of <u>culvert</u> (circle) <input type="checkbox"/> Standing water present <u>0</u> % of ditch <input type="checkbox"/> Water flowing in ditch during dry season <input checked="" type="checkbox"/> Large quantities of water flowing during wet season, or after rain event <input checked="" type="checkbox"/> Culvert showing water stains or marks <input type="checkbox"/> Soils are hydric <input type="checkbox"/> Soils are native <input checked="" type="checkbox"/> Soils are fill, sand, or clearly indicative of planned/constructed ditch <input type="checkbox"/> Soils are saturated during the dry season <input checked="" type="checkbox"/> If ditch is rock lined, there are water stained rocks to indicate a high water mark or flow line

Other Information
Does site appear to be regularly maintained? <input type="checkbox"/> yes <input type="checkbox"/> no (explain)
Has site been recently mowed? <input type="checkbox"/> yes <input type="checkbox"/> no (explain)
Length <u>293'</u> Width <u>2' to 4'</u> Total Area _____
Ditch with water flowing during site visit <u>100</u> % Ditch with standing water during site visit <u>0</u> %
Notes:

DITCH FIELD DATA SHEET

Project <u>Sound Transit East Link EXT.</u>	Date <u>4/23/2013</u>
Applicant <u>Sound Transit</u>	County/State <u>King/WA</u>
Investigators <u>C. Douglas, J. Purdley</u>	S/T/R <u>29/KYN/SE</u>

Ditch Name <u>B</u>	Photo <u>Yes</u>
Location <u>BNSF ROW</u>	
Ditch Connects to Navigable Water (jurisdictional under Talent)? <input checked="" type="checkbox"/> yes <input type="checkbox"/> no (explain) <u>West Tributary to Kelsey Creek via culverts.</u>	

Field Observations	
<p style="text-align: center;">Ditch Characteristics</p> <input checked="" type="checkbox"/> Bed and bank apparent <input checked="" type="checkbox"/> Steeply sloped <input checked="" type="checkbox"/> Vegetation flattened from possible water flow <input checked="" type="checkbox"/> Scour signs <input type="checkbox"/> Debris rack present <input type="checkbox"/> No vegetation in scour area <input checked="" type="checkbox"/> Vegetation with very shallow roots in center <input type="checkbox"/> Vegetation or soil stained with water marks <input type="checkbox"/> Vegetation is thick, deep roots, and no flow marks <input type="checkbox"/> Soil is cracked, or other evidence of ponding (explain) _____ <input checked="" type="checkbox"/> Ditch is flat and/or wide	<p style="text-align: center;">Other Observations</p> <input checked="" type="checkbox"/> Discharges into catchbasin or <u>culvert</u> (circle) <input type="checkbox"/> Standing water present <u>0</u> % of ditch <input type="checkbox"/> Water flowing in ditch during dry season <input checked="" type="checkbox"/> Large quantities of water flowing during wet season, or after rain event <input checked="" type="checkbox"/> Culvert showing water stains or marks <input type="checkbox"/> Soils are hydric <input type="checkbox"/> Soils are native <input checked="" type="checkbox"/> Soils are fill, sand, or clearly indicative of planned/constructed ditch <input type="checkbox"/> Soils are saturated during the dry season <input checked="" type="checkbox"/> If ditch is rock lined, there are water stained rocks to indicate a high water mark or flow line

Other Information
Does site appear to be regularly maintained? <input type="checkbox"/> yes <input checked="" type="checkbox"/> no (explain)
Has site been recently mowed? <input type="checkbox"/> yes <input checked="" type="checkbox"/> no (explain)
Length <u>56'</u> Width <u>2 to 3'</u> Total Area _____
Ditch with water flowing during site visit <u>30%</u> Ditch with standing water during site visit <u>0%</u>

Notes:

DITCH FIELD DATA SHEET

Project <u>Sound Transit East Link Ext.</u>	Date <u>3/6/13</u>
Applicant <u>Sound Transit</u>	County/State <u>King/WA</u>
Investigators <u>C. Douglas, S. Pursley</u>	S/T/R <u>28/24N/5E</u>

Ditch Name <u>4</u>	Photo <u>Yes</u>
---------------------	------------------

Location Adjacent to 136th pl NE

Ditch Connects to Navigable Water (jurisdictional under Talent)? Yes no (explain)
Kelsey Creek via Culverts

Field Observations	Field Observations
<p style="text-align: center;">Ditch Characteristics</p> <ul style="list-style-type: none"> <input checked="" type="checkbox"/> Bed and bank apparent <input checked="" type="checkbox"/> Steeply sloped <input checked="" type="checkbox"/> Vegetation flattened from possible water flow <input checked="" type="checkbox"/> Scour signs <input checked="" type="checkbox"/> Debris rack present <input checked="" type="checkbox"/> No vegetation in scour area <input type="checkbox"/> Vegetation with very shallow roots in center <input type="checkbox"/> Vegetation or soil stained with water marks <input type="checkbox"/> Vegetation is thick, deep roots, and no flow marks <input type="checkbox"/> Soil is cracked, or other evidence of ponding (explain) _____ <input checked="" type="checkbox"/> Ditch is flat and/or wide 	<p style="text-align: center;">Other Observations</p> <ul style="list-style-type: none"> <input checked="" type="checkbox"/> Discharges into catchbasin or <u>culvert</u> (circle) <input checked="" type="checkbox"/> Standing water present <u>50</u> % of ditch <input type="checkbox"/> Water flowing in ditch during dry season <input checked="" type="checkbox"/> Large quantities of water flowing during wet season, or after rain event <input checked="" type="checkbox"/> Culvert showing water stains or marks <input type="checkbox"/> Soils are hydric <input type="checkbox"/> Soils are native <input checked="" type="checkbox"/> Soils are fill, sand, or clearly indicative of planned/constructed ditch <input type="checkbox"/> Soils are saturated during the dry season <input type="checkbox"/> If ditch is rock lined, there are water stained rocks to indicate a high water mark or flow line

Other Information

Does site appear to be regularly maintained? yes no (explain)

Has site been recently mowed? yes no (explain)

Length 128' Width 3 to 5' Total Area _____

Ditch with water flowing during site visit 100 % Ditch with standing water during site visit 50 %

Notes:

DITCH FIELD DATA SHEET

Project <u>Sound Transit East Link EXT.</u>	Date <u>3/6/13</u>
Applicant <u>Sound Transit</u>	County/State <u>King WA</u>
Investigators <u>C. Douglas, J. Purdley</u>	S/T/R <u>28/24N/5E</u>

Ditch Name <u>6' wide</u>	Photo <u>Yes</u>
---------------------------	------------------

Location Adjacent to 136th PL NE

Ditch Connects to Navigable Water (jurisdictional under Talent)? yes no (explain)
Kelsey Creek via Culverts

Field Observations	Field Observations
<p style="text-align: center;">Ditch Characteristics</p> <ul style="list-style-type: none"> <input checked="" type="checkbox"/> Bed and bank apparent <input checked="" type="checkbox"/> Steeply sloped <input checked="" type="checkbox"/> Vegetation flattened from possible water flow <input checked="" type="checkbox"/> Scour signs <input type="checkbox"/> Debris rack present <input checked="" type="checkbox"/> No vegetation in scour area <input type="checkbox"/> Vegetation with very shallow roots in center <input checked="" type="checkbox"/> Vegetation or soil stained with water marks <input type="checkbox"/> Vegetation is thick, deep roots, and no flow marks <input type="checkbox"/> Soil is cracked, or other evidence of ponding (explain) _____ <input checked="" type="checkbox"/> Ditch is flat and/or wide 	<p style="text-align: center;">Other Observations</p> <ul style="list-style-type: none"> <input checked="" type="checkbox"/> Discharges into catchbasin or <u>culvert</u> (circle) <input type="checkbox"/> Standing water present <u>30</u> % of ditch <input type="checkbox"/> Water flowing in ditch during dry season <input type="checkbox"/> Large quantities of water flowing during wet season, or after rain event <input type="checkbox"/> Culvert showing water stains or marks <input type="checkbox"/> Soils are hydric <input type="checkbox"/> Soils are native <input checked="" type="checkbox"/> Soils are fill, sand, or clearly indicative of planned/constructed ditch <input type="checkbox"/> Soils are saturated during the dry season <input type="checkbox"/> If ditch is rock lined, there are water stained rocks to indicate a high water mark or flow line

Other Information

Does site appear to be regularly maintained? yes no (explain)

Has site been recently mowed? yes no (explain)

Length 108' Width 4' to 5' Total Area _____

Ditch with water flowing during site visit 5 % Ditch with standing water during site visit 30 %

Notes:

DITCH FIELD DATA SHEET

Project <u>SOUND TRANSIT EAST LINK EXT.</u>	Date <u>3/6/13</u>
Applicant <u>SOUND TRANSIT</u>	County/State <u>King/WA</u>
Investigators <u>C. Douglas, J. Purvisley</u>	S/T/R <u>28/24N/5E</u>

Ditch Name <u>7</u>	Photo <u>Yes</u>
---------------------	------------------

Location Adjacent to 136th PL NE

Ditch Connects to Navigable Water (jurisdictional under Talent)? yes no (explain)
Kelsey Creek via culverts

Field Observations	Field Observations
<p style="text-align: center;">Ditch Characteristics</p> <ul style="list-style-type: none"> <input checked="" type="checkbox"/> Bed and bank apparent <input checked="" type="checkbox"/> Steeply sloped <input checked="" type="checkbox"/> Vegetation flattened from possible water flow <input checked="" type="checkbox"/> Scour signs <input type="checkbox"/> Debris rack present <input checked="" type="checkbox"/> No vegetation in scour area <input checked="" type="checkbox"/> Vegetation with very shallow roots in center <input type="checkbox"/> Vegetation or soil stained with water marks <input type="checkbox"/> Vegetation is thick, deep roots, and no flow marks <input type="checkbox"/> Soil is cracked, or other evidence of ponding (explain) _____ <input checked="" type="checkbox"/> Ditch is flat and/or wide 	<p style="text-align: center;">Other Observations</p> <ul style="list-style-type: none"> <input type="checkbox"/> Discharges into catchbasin <u>or culvert</u> (circle) <input checked="" type="checkbox"/> Standing water present <u>30</u> % of ditch <input type="checkbox"/> Water flowing in ditch during dry season <input checked="" type="checkbox"/> Large quantities of water flowing during wet season, or after rain event <input checked="" type="checkbox"/> Culvert showing water stains or marks <input type="checkbox"/> Soils are hydric <input type="checkbox"/> Soils are native <input checked="" type="checkbox"/> Soils are fill, sand, or clearly indicative of planned/constructed ditch <input type="checkbox"/> Soils are saturated during the dry season <input type="checkbox"/> If ditch is rock lined, there are water stained rocks to indicate a high water mark or flow line

Other Information

Does site appear to be regularly maintained? yes no (explain)

Has site been recently mowed? yes no (explain)

Length 40' Width 2 to 3' Total Area _____

Ditch with water flowing during site visit 0 % Ditch with standing water during site visit 30 %

Notes:

DITCH FIELD DATA SHEET

Project <u>Sound Transit East Link Ext.</u>	Date <u>8/15/13</u>
Applicant <u>Sound Transit</u>	County/State <u>King / WA</u>
Investigators <u>C. Douglas, J. Burdley</u>	S/TR <u>28 / 24N / 5E</u>

Ditch Name <u>8</u>	Photo <u>Yes</u>
---------------------	------------------

Location Adjacent to S2520 Row and Commercial Development

Ditch Connects to Navigable Water (jurisdictional under Talent)? yes no (explain)
Valley Creek via Culvert

Field Observations	
Ditch Characteristics	Other Observations
<input checked="" type="checkbox"/> Bed and bank apparent <input type="checkbox"/> Steeply sloped <input type="checkbox"/> Vegetation flattened from possible water flow <input checked="" type="checkbox"/> Scour signs <input type="checkbox"/> Debris rack present <input checked="" type="checkbox"/> No vegetation in scour area <input type="checkbox"/> Vegetation with very shallow roots in center <input type="checkbox"/> Vegetation or soil stained with water marks <input type="checkbox"/> Vegetation is thick, deep roots, and no flow marks <input type="checkbox"/> Soil is cracked, or other evidence of ponding (explain) _____ <input checked="" type="checkbox"/> Ditch is flat and/or wide	<input checked="" type="checkbox"/> Discharges into catchbasin or <u>culvert</u> (circle) <input checked="" type="checkbox"/> Standing water present <u>10</u> % of ditch <input type="checkbox"/> Water flowing in ditch during dry season <input type="checkbox"/> Large quantities of water flowing during wet season, or after rain event <input checked="" type="checkbox"/> Culvert showing water stains or marks <input type="checkbox"/> Soils are hydric <input type="checkbox"/> Soils are native <input checked="" type="checkbox"/> Soils are fill, sand, or clearly indicative of planned/constructed ditch <input type="checkbox"/> Soils are saturated during the dry season <input checked="" type="checkbox"/> If ditch is rock lined, there are water stained rocks to indicate a high water mark or flow line

Other Information

Does site appear to be regularly maintained? yes no (explain)

Has site been recently mowed? yes no (explain)

Length 263' Width 4' to 5' Total Area _____

Ditch with water flowing during site visit 20 % Ditch with standing water during site visit 10 %

Notes:

APPENDIX F
STREAM FIELD STUDIES SUMMARY

Title of resource:	Streams mentioned:	Link
<p>EIS Table 4.8-3 Species of concern, potential occurrence in study area, and habitat locations within study area Table 4.8-4 Salmon spawning areas Page 31 Identify potential mitigation sites</p>	<p>Sturtevant Creek Mercer Slough East/West Kelsey Creek/West trib Sears Creek Goff Creek</p>	<p>http://www.soundtransit.org/Documents/pdf/projects/eastlink/EIS_2011/05_Chapter4-8_EcosystemResources.pdf</p>
<p>Appendix H3: Ecosystems Technical Report Section 2.1: water body recon data collected - overall habitat quality rating, habitat quality trend, water quality, in-stream habitat, riparian habitat Section 2.3: catalog existing wetland conditions and buffers, functional assessment Appendix H3-B: Wildlife Function Field Data Sheet Appendix H3-C: Priority Species and Potential Occurrence in Study Area Appendix H3-F1: Wetland and Buffer Impact Data and Maps - wetland categories and names Appendix H3-F2, F3, F4, F5, F6, F7, F8: maps wetlands, buffers, mitigation sites, etc. for each alternative</p>	<p>Mercer Slough East/West Sturtevant Creek Kelsey Creek/West trib Goff Creek Valley Creek Sears Creek</p>	<p>http://www.soundtransit.org/Documents/pdf/projects/eastlink/EIS_2011/19_AppH3_Ecosystems_Technical_Report.pdf</p>
<p>2012 Storm and Surface Water System Plan Water quality data, storm drainage and stream basin maps Full ecosystem assessment/evaluation of each stream basin - canopy cover, air quality, temperature, fish use, hydrology, soils, buffers, benthic macroinvertebrate indices, risk assessments, habitat ratings, sediment transport, etc.</p>	<p>Sturtevant Creek Sears Creek West Tributary Kelsey Creek Valley Creek Mercer Slough Goff Creek</p>	<p>http://www.ci.bellevue.wa.us/pdf/Utilities/9_Chapter_6.pdf</p>
<p>Stream Report References</p>		<p>http://green.kingcounty.gov/wlr/waterres/streamsdata/refer.aspx</p>
<p>Puget Sound Stream Benthos Analyzes the benthic macroinvertebrate structure of streams around PS to determine ecological health</p>		<p>http://www.pugetsoundstreambenthos.org/</p>
<p>BA of stream sites in the City of Bellevue, based on macroinvertebrate assemblages assessment of macroinvertebrate community structure, riparian zone health, water quality</p>	<p>Goff Creek Kelsey Creek Valley Creek</p>	<p>http://www.ci.bellevue.wa.us/pdf/Utilities/Biological_Assessment_Summary_Report_1998_to_2007.pdf</p>
<p>Bellevue critical areas update: stream inventory March 2003 stream functions and values</p>	<p>Mercer Slough Kelsey Creek Goff Creek Sears Creek Sturtevant Creek Valley Creek West Tributary</p>	<p>http://www.kitsapgov.com/dcd/lu_env/cao/bas/fw/CA_Streams_Inventory_Bellevue.pdf</p>

Title of resource:	Streams mentioned:	Link
City of Bellevue Shoreline Masterplan stream and wetland inventory maps		http://www.ci.bellevue.wa.us/pdf/Development%20Services/11a_wetlands_Internet.pdf
Kelsey Creek Basin Drainage Details Kelsey Creek Basin facts and map critical areas map		http://www.bellevuewa.gov/kelseycreekbasin.htm http://www.bellevuewa.gov/pdf/Utilities/8-KELSEY_CREEK.pdf http://www.bellevuewa.gov/pdf/Utilities/8-KELSEY_CREEK_CA.pdf
Sturtevant Creek Basin Drainage Details Sturtevant Creek Basin facts and map critical areas map		http://www.bellevuewa.gov/sturtevantcreekbasin.htm http://www.bellevuewa.gov/pdf/Utilities/22-STURTEVANT_CREEK.pdf http://www.bellevuewa.gov/pdf/Utilities/22-STURTEVANT_CREEK_CA.pdf
Bellevue Nickel Improvement Project Environmental Assessment lit review and stream surveys	Kelsey Creek Sturtevant Creek Mercer Slough	http://www.wsdot.wa.gov/NR/rdonlyres/802C0761-915E-4E58-B367-092A5D0BE468/18019/Chapter53Fish20eriesandAquaticResources.pdf
I-405 Stream Survey		http://www.wsdot.wa.gov/NR/rdonlyres/184FF391-5880-4A75-8B11-4F40F44CAE99/0/13_AppendixA.pdf
could only find appendices, but it seems like full document might be useful... Mercer Slough		
City of Bellevue Stream Typing Inventory mostly fish-oriented, but has lots of detailed information about habitat availability	Mercer Slough Sturtevant Creek Kelsey Creek West Tributary Goff Creek Valley Creek Sears Creek	http://www.ci.bellevue.wa.us/pdf/Utilities/Streamtyping_Report.pdf
Goff Creek Basin Drainage Details		http://www.bellevuewa.gov/goffcreekbasin.htm
Valley Creek Basin Drainage Details		http://www.bellevuewa.gov/ValleyCreekBasin.htm
Sears Creek Basin Drainage Details		http://www.bellevuewa.gov/searscreekbasin.htm

ATTACHMENT E

East Link | South Bellevue to Overlake Transit Center

East Link Light Rail Extension-

Critical Areas Report

and

Mitigation Plan

June 2015

Prepared for:



Prepared by:



FINAL DESIGN PARTNERS.

EXECUTIVE SUMMARY

- PROJECT NAME:** East Link Light Rail Extension – South Bellevue to Overlake Transit Center
- LOCATION:** The Project alignment is 7.13 miles long, beginning at the juncture of Interstate 90 (I-90) and the eastern shoreline of Lake Washington in Bellevue, Washington (47.58 N latitude [lat]/ -122.20 W longitude [long]) and ending at the Overlake Transit Center in Redmond, Washington (47.65 N lat/ -122.13 W long). There is also project mitigation occurring within Coal Creek just east of I-405 (47.57 N lat/ -122.18 W long) (Figure 1-1).
- APPLICANT:** The Central Puget Sound Regional Transit Authority (Sound Transit)

PROPOSED PROJECT:

The goal of the East Link Light Rail Extension Project (Project) is to expand the Sound Transit East Link light rail system from Seattle to Mercer Island, Bellevue, and Redmond to provide a reliable and efficient alternate mode of transportation throughout the region. The elements of the Project that are located within the City of Bellevue include approximately 6 miles of new light rail track, six rail stations, two parking facilities, and other supporting facilities and infrastructure associated with the Project. Approximately 1 additional mile of track and a rail station are located in the City of Redmond; however, these improvements will not impact critical areas and are therefore not addressed in this report.

EXISTING CONDITIONS:

The Project area within the City of Bellevue where construction will occur is located in a heavily populated area that includes residential communities, office complexes, and the downtown city center. Critical areas were identified within the Project area, in accordance with the City of Bellevue Land Use Code (LUC; LUC 20.25H.030). These include 21 wetlands, 10 streams, geologic hazard areas, special flood hazard areas, and habitats associated with species of local importance. An additional 6 wetlands and one stream were delineated separate from this Project. These waterbodies are located at the compensatory mitigation project located off-site on Coal Creek. Only Coal Creek and one adjacent wetland that will be impacted at the site are described in further detail below. The other five wetlands at the Coal Creek mitigation site are not affected.

IMPACT ASSESSMENT AND PROPOSED MITIGATION:

Sincere efforts have been made to avoid and minimize potential impacts to critical areas within the Project area. These avoidance and minimization efforts have successfully eliminated any long-term impacts to geologic hazard areas, areas of special flood hazard, and species and habitats of local importance to the City of Bellevue; however, some impacts to wetlands and streams are anticipated. Tables ES-1 and ES-2 on the following page provide a summary of permanent and temporary impacts to wetlands, streams, and their buffers.

Mitigation for potential impacts to these critical areas is proposed within the City of Bellevue in areas within or adjacent to the Project area. Mitigation concepts follow Sound Transit's commitment to a "no net loss" of wetland area and function and provide a surplus of functions to ensure the required mitigation ratios are met. Tables ES-3, ES-4, and ES-5 provide summary information for the proposed mitigation for wetland and stream impacts. All temporary impacts are "self-mitigating," with some additional mitigation to address the potential temporal loss of habitat. See Section 3 for more detail.

Table ES-1 Project Wetland and Wetland Buffer Impact Summary

Site	Drainage Sub-basin	Permanent Impact (acres)	Permanent Vegetation Conversion (acres)	Temporary Impact (acres)	Permanent Buffer Impact (acres)	Temporary Buffer Impact (acres)
Mercer Slough	Mercer Slough	0.17 ^a	0.32	0.22	4.10	4.43
Alcove Creek	Mercer Slough	0.00	0.00	0.01	0.09	0.08
Bellefield South	Mercer Slough	0.05	0.00	0.04	0.20	0.01
Bellefield North	Mercer Slough	0.01	0.00	0.02	0.24	0.04
8th Street	Mercer Slough	0.13	0.00	0.00	0.00	0.00
South Lake	Sturtevant Creek	0.00	0.09	0.00	0.01	0.27
Central Lake	Sturtevant Creek	0.00	0.03	0.00	0.05	0.09
North Lake	Sturtevant Creek	0.00	0.00	0.04	0.00	0.00
BNSF West	West Tributary	0.00	0.00	0.00	0.09	0.00
BNSF East	West Tributary	0.05	0.08	0.00	0.14	0.01
BNSF Northeast	West Tributary	0.00	0.00	0.00	0.04	0.00
Kelsey West Tributary Pond	West Tributary	0.01	0.00	0.05	0.13	0.36
SR 520 West	Valley Creek	0.01	0.23	0.00	0.01	0.55
Valley Creek	Valley Creek	0.00	0.01	0.00	0.01	0.27
Total Wetland Impacts:		0.43	0.76	0.38	5.11	6.11

Notes:

a This includes .02 acre of fill from pin piles, which is not regulated by the U.S. Army Corps of Engineers.

SR 520 = State Route 520

Table ES-2 Project Stream and Stream Buffer Impact Summary

Stream	Local Stream Rating	Permanent Impacts (sf)	Temporary Impacts (sf)	Permanent Buffer Impacts ¹ (acres)	Temporary Buffer Impacts (acres)
Wye Creek	Type F	420	110	0.09	0.11
Alcove Creek	Type F	236	33	0.00	0.00
Sturtevant Creek	Type F	3,443 ²	382	0.21	0.37
West Tributary to Kelsey Creek	Type F	0	3,814	0.02	0.12
Stream C	Type O	0	1,560	0.07	0.08
Goff Creek	Type F	0	0	0.03	0.00
Unnamed Tributary to Kelsey Creek	Type N	2,887	139	0.09	0.00
Total Stream Impacts		6,986	6,038	0.51	0.68

Notes:

1 Areas only include stream buffer where there is no wetland buffer overlap. Overlapping buffer areas are counted as wetland buffers and included in Table ES-1.

2 Includes 247 square feet for shading from a pedestrian bridge.

sf = square feet

Table ES-3 Project Wetland, Stream, and Buffer Mitigation Site Summary for Permanent Impacts

Mitigation Site	Drainage Sub-basin	Proposed Mitigation				
		Wetland Rehabilitation (acres)	Wetland Enhancement (acres)	Wetland Creation (acres)	Stream Restoration ¹ (sf)	Wetland and Stream Buffer Creation / Enhancement (acres)
Sweyolocken	Mercer Slough	1.50	4.87	N/A	N/A	0.85
Sturtevant Creek	Sturtevant Creek	N/A	N/A	N/A	3,500	0.17
Mercer Slough / Bellefield	Mercer Slough	N/A	0.21	N/A	527 ²	3.76
West Tributary	West Tributary	N/A	0.04 ³	0.55	3,814 (see Table ES-5)	1.15
Coal Creek	Coal Creek	N/A	N/A	N/A	10,736 (see Table ES-5)	N/A
Total Mitigation Area		1.50	5.12	0.55	18,577	5.93

Notes:

- 1 Refer to Section 3 for complete functional lift analysis of the proposed mitigation.
 - 2 Includes 465 sf of stream restoration and 62 sf of stream daylighting at Wye Creek to mitigate for impacts to Wye Creek and Alcove Creek. See Table ES-5 for more detail.
 - 3 Enhancement occurs within Kelsey West Tributary Wetland
- sf = square feet

Table ES-4 Proposed Project Wetland Mitigation Summary as Compared to Regulatory Requirements

Required Mitigation ¹	Proposed Mitigation
4.78 Acres of Wetland Enhancement	5.12 Acres of Wetland Enhancement ² (4.87 at Sweyolocken, 0.14 at Bellefield South, 0.07 at Bellefield North, and 0.04 at Kelsey West Tributary Stream Wetland)
1.38 Acres of Wetland Rehabilitation	1.50 Acres of Wetland Rehabilitation at Sweyolocken
0.41 Acre of Wetland Creation	0.55 Acre of Wetland Creation at West Tributary
5.62 Acres of Buffer Creation/Enhancement	5.93 Acres of Buffer Creation/Enhancement

Notes:

- 1 Mitigation requirements are based on ratios established by Washington Department of Ecology, US Army Corps of Engineers Seattle District, and Environmental Protection Agency, Region 10 guidance (Ecology et al. 2006). Mitigation required for "vegetation conversion" in wetlands is included (see Table 3-1 of this report for further detail).
- 2 To mitigate for temporal loss from temporary impacts, an additional ¼ of the normal mitigation ratio for permanent impacts was used to calculate the amount of wetland mitigation required. The area of mitigation required for temporal loss from temporary impacts is included in the 5.12 acres of enhancement. Details for each wetland are provided below in Section 3.2.

Table ES-5 Project Permanent Stream Impacts and Proposed Mitigation

Stream	Local Stream Rating	Permanent Impacts (sf)	Proposed Mitigation
Wye Creek	Type F	420 (shading from guideway bridge and relocation)	420 sf of restored (relocated) Wye Creek
Alcove Creek	Type F	236 (shading from guideway bridge)	62 sf of stream daylighting at Wye Creek and 45 sf of restored (relocated) Wye Creek
Sturtevant Creek	Type F	3,443 (relocation) (247 shading from pedestrian bridge) Perpetuating existing fish passage barrier	3,500 sf of restored (relocated) Sturtevant Creek 3,814 sf of stream channel enhancement on West Tributary to Kelsey Creek Installation of fish passage culvert on Goff Creek
Unnamed Tributary to Kelsey Creek	Type N	2,887 (from at-grade guideway)	10,736 sf of stream channel enhancement on Coal Creek.

Note:

sf = square feet

Contents

1.0	Introduction	1-1
1.1	Project Purpose and Goals	1-1
1.2	Project Description.....	1-2
1.2.1	Project Elements and Phasing.....	1-2
1.2.2	Construction Methods	1-2
1.3	Project Setting.....	1-6
1.3.1	Review of Existing Information	1-6
1.3.2	Topography	1-6
1.3.3	Soils	1-6
1.3.4	Hydrology	1-7
1.3.5	Plant Communities and Habitat	1-8
1.4	Project Compliance with City Code Performance Standards and Criteria	1-10
1.4.1	Consistency with Light Rail Overlay District (Chapter 20.25M LUC)	1-10
1.4.2	Performance Standards.....	1-11
1.4.3	LUC 20.25H.055.C.2.....	1-11
1.4.4	LUC 20.25H.080.A and LUC 20.25H.080.B	1-12
1.4.5	LUC 20.25H.100.....	1-14
1.4.6	LUC 20.25H.125.....	1-15
1.4.7	LUC 20.25H.145.....	1-17
1.4.8	LUC 20.25H.180.C.....	1-19
2.0	Critical Areas Assessment	2-1
2.1	Habitat Associated with Species of Local Importance	2-1
2.1.1	Methods	2-1
2.1.2	Vegetation Communities	2-1
2.1.3	Fish and Wildlife Habitat.....	2-3
2.1.4	Species of Local Importance	2-4
2.1.5	Federally Protected Species and Critical Habitats	2-8
2.1.6	Impact Assessment for Habitat Associated with Species of Local Importance	2-9
2.2	Wetlands	2-11
2.2.1	Methods	2-13
2.2.2	Wetland Study Results	2-14
2.2.3	Wetland Functional Analysis	2-24
2.2.4	Wetland Impact Assessment.....	2-30
2.2.5	Wetland Regulatory Compliance	2-40
2.3	Streams	2-42
2.3.1	Methods	2-42
2.3.2	Stream Study Results	2-43
2.3.3	Stream Characteristics	2-49
2.3.4	Stream Impact Assessment.....	2-51
2.3.5	Stream Regulatory Compliance.....	2-55
2.4	Areas of Special Flood Hazard.....	2-56
2.4.1	Methods	2-56
2.4.2	Study Results	2-56
2.4.3	Project Impact on Special Flood Hazards and Mitigation	2-56
2.5	Geologic Hazard	2-60

2.5.1	Methods	2-60
2.5.2	Study Results	2-61
2.5.3	Project Impact on Geologic Hazards	2-67
2.6	Probable Cumulative Impacts	2-67
2.6.1	Wetlands, Streams, and Habitat Associated with Species of Local Importance	2-67
2.6.2	Geology and Soils	2-68
2.6.3	Floodplains	2-68
3.0	Mitigation.....	3-1
3.1	Mitigation Sequence	3-6
3.1.1	Measures to Avoidance and Minimization Impacts.....	3-6
3.1.2	Measures to Rectify and Restore Impacts	3-8
3.2	Compensatory Mitigation	3-13
3.2.1	Sweyolocken Site.....	3-13
3.2.2	Sturtevant Creek	3-19
3.2.3	West Tributary	3-21
3.2.4	Mercer Slough/Bellefield	3-23
3.2.5	Coal Creek	3-26
3.3	Wetland Mitigation Site Functional Lift Analysis	3-27
3.3.1	Water Quality Functions	3-30
3.3.2	Comparison between Functions and Values of Disturbed Wetlands and Wetland Mitigation Sites.....	3-31
3.4	Goals, Objectives, and Performance Standards.....	3-39
3.4.1	Goal 1: Restore Wetland Hydrology at the Sweyolocken and West Tributary Mitigation Sites	3-39
3.4.2	Goal 2: Establish Native Plant Communities at the Sweyolocken, Mercer Slough/Bellefield, Sturtevant Creek, and West Tributary Mitigation Sites.....	3-40
3.4.3	Goal 3: Create Stable Channels at the Sturtevant Creek and Restore Reaches at the West Tributary and Coal Creek Mitigation Sites that Increase Habitat Diversity and Channel Forming Processes.....	3-40
3.4.4	Goal 4: Improve Wildlife and Aquatic Habitat at the Sweyolocken, Mercer Slough/Bellefield, Sturtevant Creek, and West Tributary Mitigation Sites.....	3-42
3.4.5	Goal 5: Restore Wetland, Stream, and Buffer Areas Temporarily Impacted during Construction to Pre-existing or Better Conditions.....	3-42
3.4.6	Goal 6: Improve habitat quality, habitat diversity and diversity of prey resources in the Coal Creek Restoration Site	3-43
3.5	Monitoring, Maintenance, and Contingency Plan	3-43
3.5.1	Baseline Monitoring	3-43
3.5.2	Post-construction Monitoring.....	3-43
3.5.3	As-built or Year 0 Monitoring.....	3-44
3.5.4	Methods to Monitor Progress in Attaining the Performance Standards.....	3-44
3.5.5	Wetland Hydrology	3-44
3.5.6	Stream Hydrology and Condition.....	3-44
3.5.7	Vegetation Monitoring.....	3-44
3.5.8	Habitat Use.....	3-45
3.5.9	Monitoring Schedule.....	3-45
3.5.10	Maintenance Actions	3-46
3.5.11	Contingency Plan.....	3-47

3.5.12 Long Term Management Plan3-51

4.0 References4-1

Tables

Table ES-1 Project Wetland and Wetland Buffer Impact Summary iii

Table ES-2 Project Stream and Stream Buffer Impact Summary iv

Table ES-3 Project Wetland, Stream, and Buffer Mitigation Site Summary for Permanent Impacts v

Table ES-4 Proposed Project Wetland Mitigation Summary as Compared to Regulatory Requirements v

Table 1-1 City of Bellevue Performance Standards for Proposed Elements of Light Rail Project in Critical Areas..... 1-11

Table 2-1 Plant Species Observed within the Project Area..... 2-1

Table 2-2 Summary of City of Bellevue Designated Species of Local Importance Potential Presence within the Project Area 2-5

Table 2-3 Federally Listed and Proposed Species, ESA Status, Critical Habitat, and Effect Determinations..... 2-8

Table 2-4 Summary of Wetlands Located within the Project Area..... 2-15

Table 2-5 Summary of Wetland USFWS Classification, Hydrogeomorphic Classification, State and Local Ratings, and Local Buffer Widths 2-16

Table 2-6 Summary of Wetland Function Rating Categories..... 2-25

Table 2-7 Summary of Functions and Values Wetland Rating Scores 2-26

Table 2-8 Summary of Permanent Wetland Impacts..... 2-32

Table 2-9 Summary of Permanent Wetland Impacts by Classification..... 2-33

Table 2-10 Summary of Temporary Wetland Impacts..... 2-34

Table 2-11 Summary of Permanent Wetland Buffer Impacts..... 2-36

Table 2-12 Summary of Temporary Wetland Buffer Impacts..... 2-37

Table 2-13 Summary of Wetland Vegetation Conversion Impacts..... 2-40

Table 2-14 City of Bellevue Wetland and Wetland Buffer Regulations 2-41

Table 2-15 City of Bellevue Regulations Wetland Rating and Buffer Distance..... 2-41

Table 2-16 Summary of Streams Located within the Project Area 2-44

Table 2-17 Local Critical Areas Regulations Stream Rating and Buffer Distance..... 2-45

Table 2-18 Summary of Permanent Stream Impacts..... 2-52

Table 2-19 Summary of Temporary Stream Impacts 2-53

Table 2-20 Summary of Permanent Stream Buffer Impacts..... 2-54

Table 2-21 Summary of Temporary Stream Buffer Impacts 2-55

Table 2-22 East Link Alignment Cross Sections for Steep Slope Screening 2-61

Table 2-23 Geologic Hazard Steep Slopes.....	2-62
Table 3-1 Project Wetland Impacts and Proposed Mitigation Summary	3-2
Table 3-2 Proposed Project Wetland Mitigation Summary Compared to Regulatory Requirements	3-3
Table 3-3 Project Stream Impacts and Proposed Mitigation.....	3-4
Table 3-4 Summary of Permanent Wetland Buffer Impacts.....	3-5
Table 3-5 Summary of Permanent Stream Buffer Impacts.....	3-6
Table 3-6 Summary of Temporary Wetland Impacts.....	3-8
2 Estimated as “greater than one-acre” by David Evans and Associates, Inc. (2007).Table 3-7 Summary of Temporary Wetland Buffer Impacts	3-9
Table 3-8 Summary of Temporary Stream Impacts	3-9
Table 3-9 Summary of Temporary Stream Buffer Impacts ¹	3-10
Table 3-10 Wetland Mitigation Sites Classifications and Ratings Based on the Design Approach.....	3-28
Table 3-11 Summary of Functions and Values for Proposed Wetland Mitigation Site Rating Scores	3-29
Table 3-12 Summary of Wetland Rating Scores and Sweyolocken Mitigation Site Functional Lift.....	3-32
Table 3-13 Summary of Wetland Rating Scores and West Tributary Mitigation Site Functional Lift.....	3-33
Table 3-14 Summary of Wetland Rating Scores and Mercer Slough/Bellefield Mitigation Site Functional Lift	3-35
Table 3-15 Projected Calendar for Performance Monitoring and Maintenance Events	3-45
Table 3-16 Potential Contingency Actions for the Wetland Mitigation Site.....	3-49
Table 3-17 Potential Contingency Actions for the Stream Mitigation Site.....	3-50

Figures

Figure 1-1 Vicinity Map and Project Alignment	1-3
Figure 1-2 Typical East Link at Grade Guideway Detail.....	1-4
Figure 1-3 Typical East Link Elevated Guideway Detail.....	1-5
Figure 1-4 Drainage Basin Boundaries	1-9
Figure 2-1 Existing Wetlands and Streams	2-12
Figure 2-2 Schematic Representation of Impacts and Mitigation for Elevated Guideway.....	2-39
Figure 2-3 Floodplain Boundary at Sweyolocken.....	2-58
Figure 2-4 Floodplain Boundary at Coal Creek	2-59
Figure 3-1 Proposed Mitigation Sites.....	3-15

Appendices

Appendix A	Wetland and Stream Resource Maps
Appendix B	Wetland, Stream, and Buffer Impacts
Appendix C	Wetland, Stream, and Buffer Mitigation Plans
Appendix D	Proposed Mitigation and Restoration Design
Appendix E	Geologic Hazard Areas
Appendix F	Impact and Mitigation Summary by Contract Package
Appendix G	FEMA Habitat Assessment
Appendix H	Coal Creek Stream Enhancement Project Hydraulic Effects Memorandum

Acronyms and Abbreviations

BA	Biological Assessment
BCC	Bellevue City Code
BFE	base flood elevation
BMP	best management practice
BNSF	Burlington Northern Santa Fe
CAO	Critical Areas Ordinance
CAR	Critical Areas Report and Mitigation Plan
cfs	cubic feet per second
City	City of Bellevue
Corps	U.S. Army Corps of Engineers
DCM	Design Criteria Manual
Delineation Report	<i>Sound Transit East Link Extension Project Wetland, Stream, and Jurisdictional Ditch Delineation Report</i>
DPS	distinct population segment
DTM	digital terrain model
Ecology	Department of Ecology
EFH	essential fish habitat
EIS	Environmental Impact Statement
ESA	Endangered Species Act
ESU	evolutionary significant units
FB	forested buffer
FEMA	Federal Emergency Management Agency
FIRM	Flood Insurance Rate Maps
FW	forested wetland
GPS	global positioning system
HGM	Hydrogeomorphic
I-90	Interstate 90
I-405	Interstate 405
LUC	Land Use Code
LWD	large woody debris
Magnuson-Stevens Act	Magnuson-Stevens Fishery Conservation and Management Act

NGVD88	National Geodetic Vertical Datum 1988
NMFS	National Marine Fisheries Service
NRCS	Natural Resource Conservation Service
NWI	National Wetlands Inventory
OHWM	ordinary high water mark
PAB	Palustrine aquatic bed
PEM	Palustrine emergent
PFO	Palustrine forested
PHS	Priority Habitats and Species
Project	East Link Light Rail Extension Project
PSS	Palustrine Scrub-Shrub
RCW	Revised Code of Washington
RLRT	Regional Light Rail Transit
RM	river mile
ROD	Record of Decision
ROE	right-of-entry
ROW	right-of-way
SEPA	State Environmental Policy Act
sf	square feet
Sound Transit	Central Puget Sound Regional Transit Authority
SR 520	State Route 520
SSB	scrub-shrub buffer
SSBL	scrub-shrub buffer low
SSW	scrub-shrub wetland
USFWS	United States Fish and Wildlife Service
VCZ	vegetation clear zone
WAC	Washington Administrative Code
WDFW	Washington Department of Fish and Wildlife
WRIA 8	Water Resource Inventory Area 8
WSDOT	Washington Department of Transportation

1.0 Introduction

This Critical Areas Report and Mitigation Plan (CAR) describes existing conditions in support of project planning and permitting for the Central Puget Sound Regional Transit Authority (Sound Transit) East Link Light Rail Extension Project (Project). This report addresses potential impacts to critical areas as defined by the Bellevue City Code (BCC) and proposed mitigation within the City of Bellevue (City), and is intended to support Shoreline and Design and Mitigation Review permit reviews, as defined in the Light Rail Overlay District requirements (Land Use Code [LUC] 20.25M).

The purpose of this CAR is to describe the existing critical areas within the Project area, evaluate the potential impacts to critical areas, and provide a mitigation plan to address these impacts. Critical areas are defined in the BCC Critical Areas Ordinance (CAO), contained in Chapter 20.25H of the LUC (City of Bellevue 2013a). Per Chapter 20.25H.250 of the LUC, this CAR identifies and classifies critical areas and applicable critical area buffers present in the Project area. Sound Transit, in coordination with the City, identified the following five types of critical areas within the Project area: Streams (LUC 20.25H.075), Wetlands (LUC 20.25H.095), Geologic Hazard Areas (LUC 20.25H.120), Habitat Associated with Species of Local Importance (LUC 20.25H.150) and Areas of Special Flood Hazard (LUC 20.25H.175). The Project area also includes shorelines classified under the CAO (LUC 20.25E.017); however, the evaluation of potential impacts and associated mitigation related to shorelines is documented separately as part of the Shoreline Substantial Development Permit process with the City, with the exception of shoreline critical area buffers. Shoreline critical area buffers impacted by the Project overlap in all cases with stream and wetland critical area buffers; therefore, shoreline critical area buffer impacts and mitigation are covered by the critical area buffer discussion in this document.

This report is organized as follows. First a description of the Project, the Project setting, and relevant regulatory context is provided (Section 1). Next, a description of the existing critical areas within the Project area is presented, along with the potential impacts to critical areas from the Project (Section 2). Finally, measures to avoid and minimize impacts, and compensatory mitigation concepts for unavoidable impacts are presented (Section 3). The report is intended to satisfy the requirements of the Bellevue LUC (LUC 20.25H.250), as well as to demonstrate how the proposed mitigation will lead to equivalent or better protection of remaining critical area functions and values than would result from the application of the standard requirements.

1.1 Project Purpose and Goals

The purpose of the Project is to expand the Sound Transit Link light rail system from Seattle to Mercer Island, Bellevue, and Redmond via Interstate 90 (I-90), and to provide a reliable and efficient alternative for moving people throughout the region. The Project would provide greater capacity and reliability, as well as improving travel time for people traveling between Seattle, Bellevue, and Redmond. To meet planned growth in the corridor, the cities of Bellevue, Seattle, and Redmond have made land use and planning decisions based upon increased employment and residential density, which would be more

fully realized with the long-term promise of a high-capacity transit connection across I-90. East Link provides this connection.

1.2 Project Description

The Project in its entirety extends the light rail system approximately 14 miles between Seattle and the east side of Lake Washington and includes ten stations serving Seattle, Mercer Island, South Bellevue, Downtown Bellevue, Bel-Red, and Overlake areas. The Project corridor is located in King County, Washington, the most densely populated county of the Puget Sound region. The Project has received concurrence from the Federal Transit Administration, and the Federal Transportation Department through completion of an Environmental Impact Statement (EIS) and subsequent Record of Decision (ROD). In addition, the State Environmental Policy Act (SEPA) review has been completed. The City has concurred with the Project alignment and major design elements through formal City Council action taken in April 2013.

1.2.1 Project Elements and Phasing

The Project features described in this report occur within the City between I-90 on the east side of Lake Washington in Bellevue and State Route 520 (SR 520) in Redmond (Figure 1-1), and represent approximately 6 miles of the overall East Link Project.

The Project corridor extends north from I-90, runs along the east side of Bellevue Way, then runs along the east side of 112th Avenue SE. The alignment then crosses to the west side of 112th Avenue SE at SE 15th Street and heads into Downtown Bellevue via a tunnel under 110th Avenue NE. From Downtown Bellevue, the Project alignment extends east along the south side of NE 6th Street, crosses over Interstate 405 (I-405), then turns north at the existing Burlington Northern Santa Fe (BNSF) rail corridor. The alignment follows the BNSF corridor north to NE 12th Street, then heads east following NE 16th Street right-of-way (ROW). The alignment then heads northeast within the 136th Place NE ROW, then turns east again within the SR 520 ROW. The Project remains in the SR 520 ROW until it reaches the Overlake Transit Center Station at NE 40th Street in Redmond.

The elements of the Project that are located within the City limits include approximately 6 miles of new light rail track, six stations, two parking facilities, and other facilities and infrastructure associated with the Project.

1.2.2 Construction Methods

The light rail alignment and stations vary in profile through the East Link corridor—at-grade, trenched, retained cut/fill, elevated, and a tunnel in the downtown core of the City (Figures 1-1, 1-2, and 1-3). Construction of the light rail line in the City would include civil construction and systems installation involving demolition work, clearing and grading, fill and excavation, utility extensions and/or relocations, tunneling, and retaining wall installation. Construction would occur over a 6-year period, with the majority of physical excavation and construction occurring within the first 4 years, after which construction would primarily involve station and tunnel finishing, and systems installation.

LEGEND

- ELEVATED GUIDEWAY
- TRENCHED GUIDEWAY
- RETAINED CUT-FILL/AT GRADE GUIDEWAY
- TUNNELED GUIDEWAY
- STATION
- Ⓟ PARK-AND-RIDE

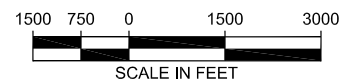
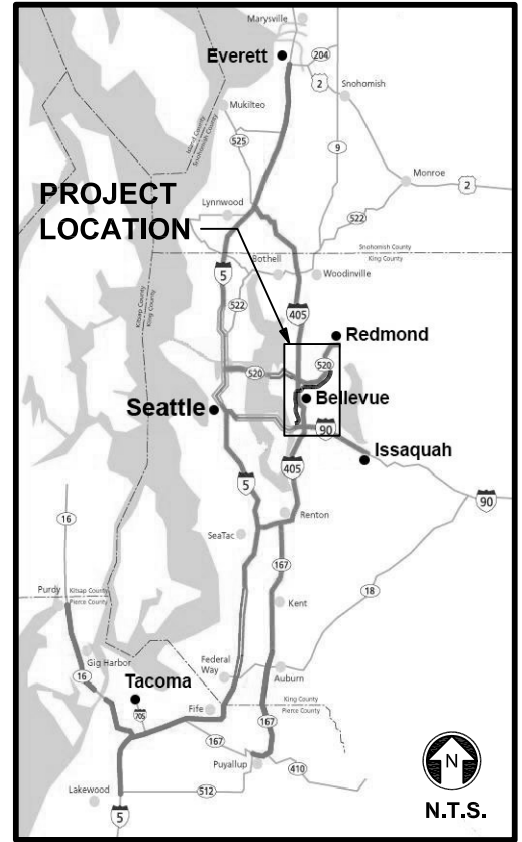
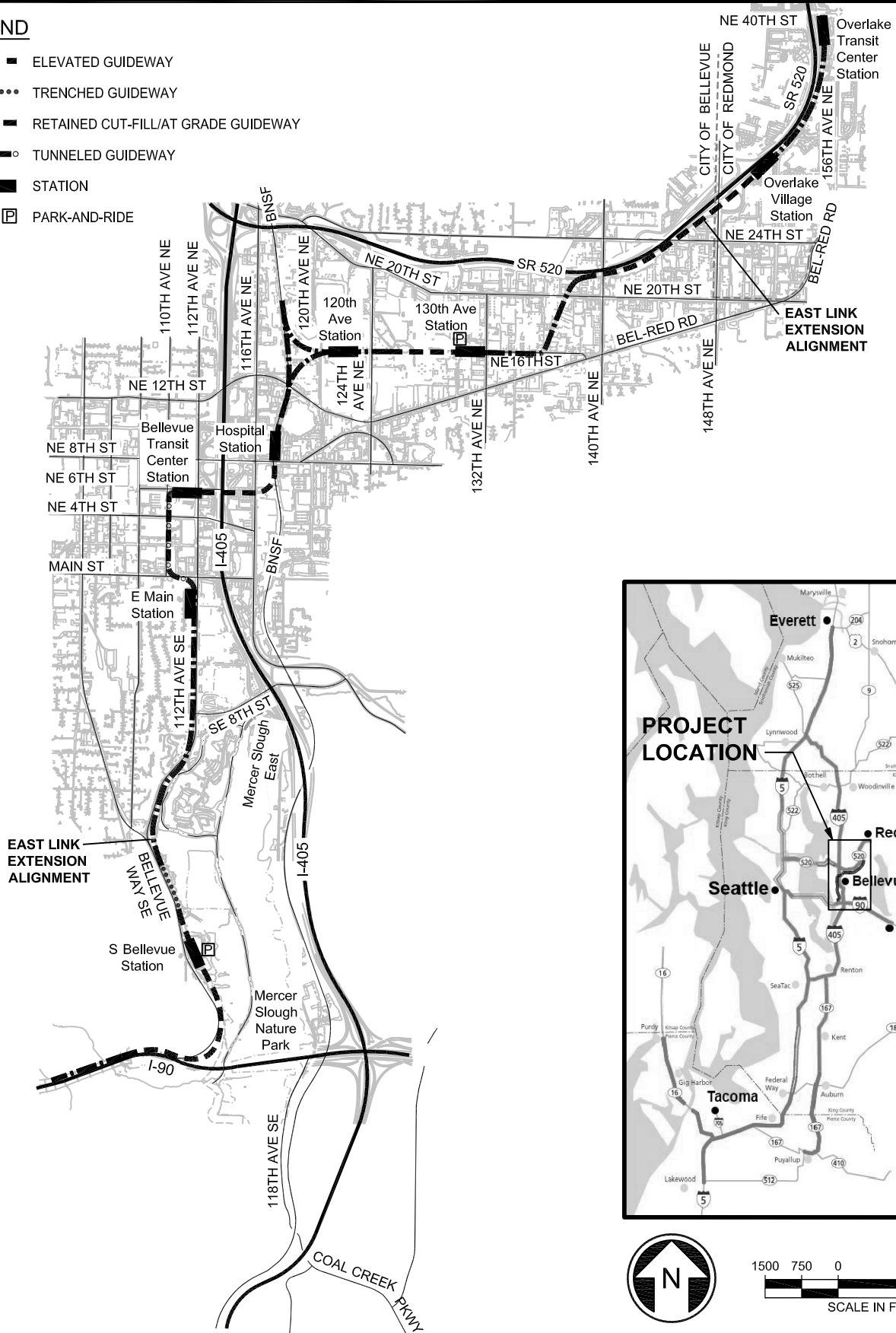

EAST LINK EXTENSION
SOUTH BELLEVUE TO OVERLAKE TRANSIT CENTER
 FIGURE 1-1
 VICINITY MAP AND PROJECT ALIGNMENT

05/07/15 | 9:21 AM | J.LOGAN
 J:\55229\CADD\5001\DRAWINGS\ARCH\CRITICAL AREAS REPORT\REPORT FIGURES\CAR-1.DWG

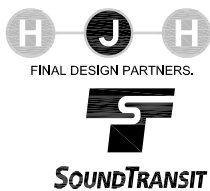

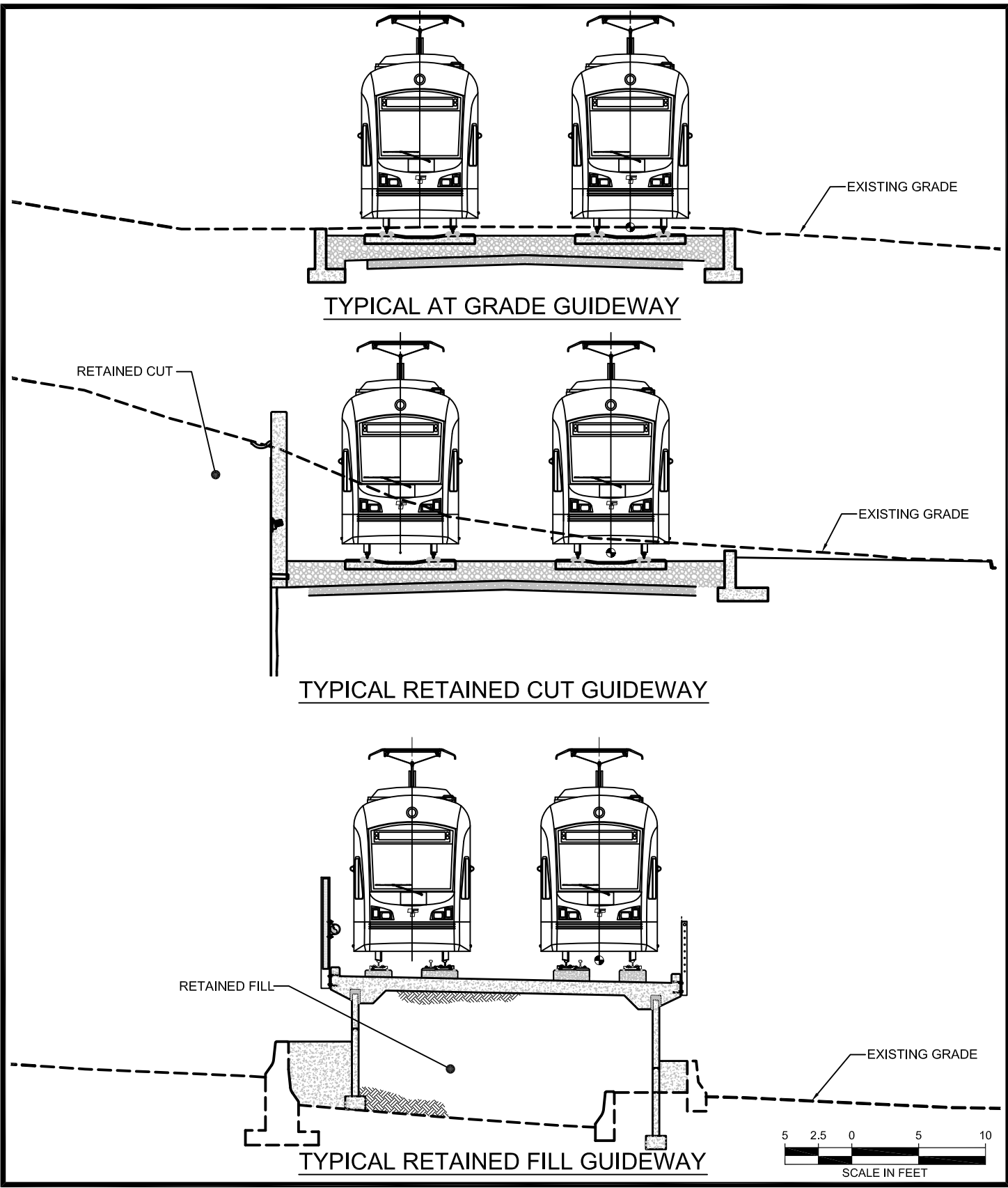

05/07/15 | 10:34 AM | JLOGAN
J:\65229\CADD\5001\DRAWINGS\ARCH\CRITICAL AREAS REPORT\REPORT FIGURES\CAR1-2.DWG



EAST LINK EXTENSION
SOUTH BELLEVUE TO OVERLAKE TRANSIT CENTER
 FIGURE 1-2
 TYPICAL EAST LINK AT GRADE
 GUIDEWAY DETAIL

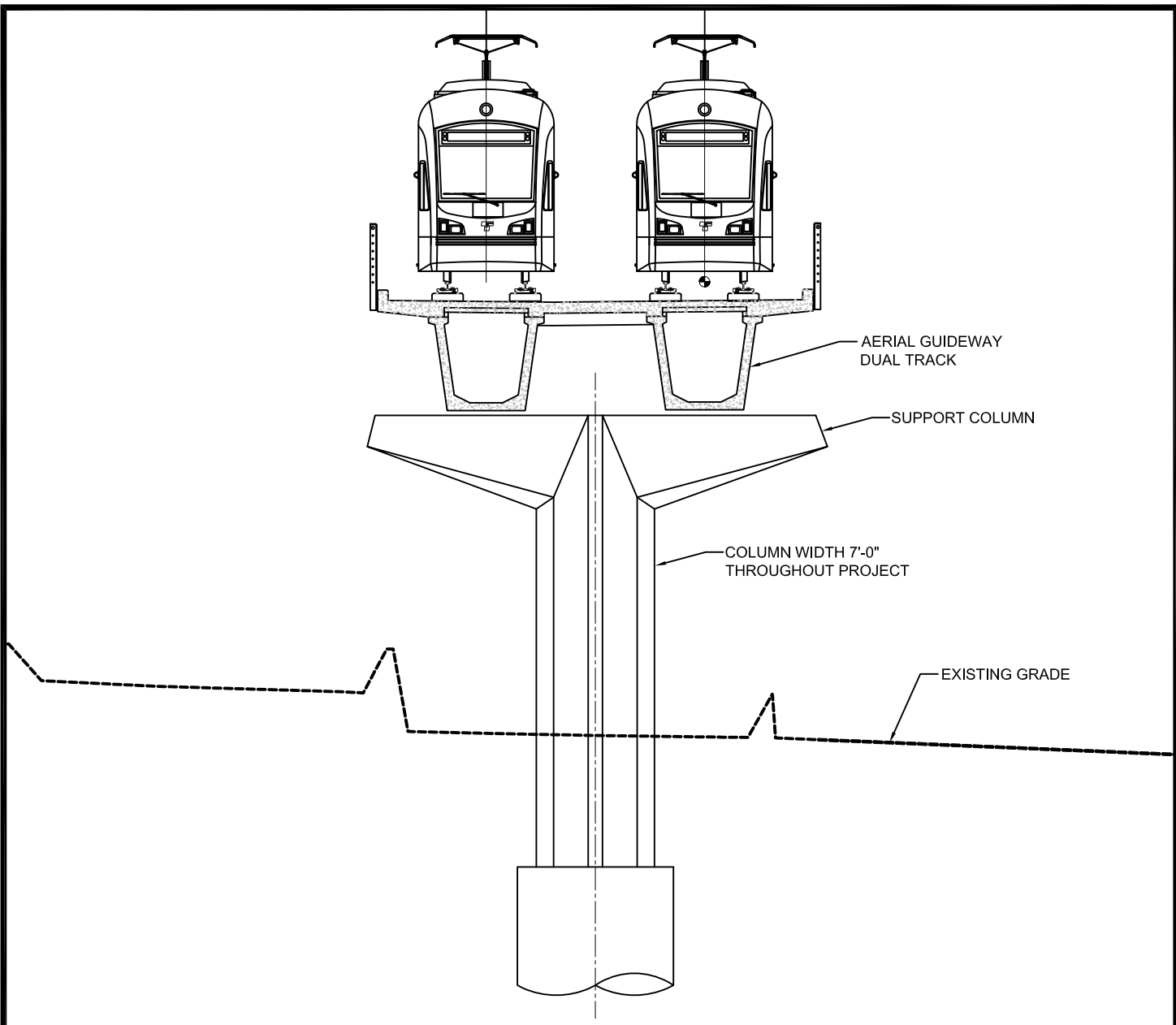

TYPICAL ELEVATED GUIDEWAY

05/07/15 | 10:35 AM | J.LOGAN
 J:\65229\CADD\5001\DRAWINGS\ARCH\CRITICAL AREAS REPORT\REPORT FIGURES\CAR1-3.DWG

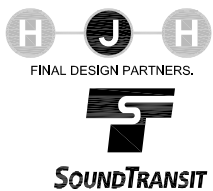

EAST LINK EXTENSION
SOUTH BELLEVUE TO OVERLAKE TRANSIT CENTER

FIGURE 1-3
 TYPICAL EAST LINK ELEVATED
 GUIDEWAY DETAIL

1.3 Project Setting

The portion of the Project area addressed in this report is located within lowland areas adjacent to Lake Washington within the City limits (Figure 1-1). The Project area where construction will occur is largely within a densely populated area of the City that includes residential communities, office complexes, and the downtown city center. This area includes property under a variety of ownerships, including Washington State Department of Transportation (WSDOT) and City roads and ROWs, and parcels under City and private commercial or residential ownership. Also present in the Project area are streams, wetlands, and other critical areas, which are the subject of this report. Appendix A provides a series of maps of the Project area, including wetland and stream locations.

1.3.1 Review of Existing Information

As part of the analysis to identify natural resources and critical areas in the Project area, literature and information sources on topography, soils, hydrology, and plant communities and habitats were reviewed. The following sources of information were used to support field observations:

- Natural Resource Conservation Service (NRCS) Web Soil Survey (USDA 2013a)
- Hydric Soil List for Washington State (USDA 2013b)
- U.S. Fish and Wildlife Service (USFWS) Wetlands Mapper for National Wetlands Inventory (NWI) Map Information (USFWS 2013)
- Washington Department of Fish and Wildlife (WDFW) Priority Habitats and Species Maps (WDFW 2013a)
- WDFW SalmonScape Interactive mapper (WDFW 2013b)
- BCC (City of Bellevue 2013a)
- Bellevue Critical Areas Maps (City of Bellevue 2013b)
- East Link Light Rail Project Final Environmental Impact Statement and technical appendices (Sound Transit 2011)
- Google Earth aerial imagery (February to April 2013)

1.3.2 Topography

The topography in the Project area is typical of lowland areas east of Lake Washington. The majority of the Project area includes engineered slopes associated with existing roads and commercial and residential development. More distinct changes in elevation within the Project area are typically associated with critical area features, such as wetlands and streams, as these features are typically located in low lying areas and depressions compared to upland and developed areas.

1.3.3 Soils

The *NRCS Web Soil Survey* (USDA 2013a) identifies twelve soil series in the Project area:

- Alderwood gravelly sandy loam 0 to 6 percent slopes (AgB)

- Alderwood gravelly sandy loam 6 to 15 percent slopes (AgC)
- Alderwood gravelly sandy loam 15 to 30 percent slopes (AgD)
- Arents—Alderwood material 6 to 15 percent slopes (AmC)
- Bellingham silt loam (Bh)
- Everett-Alderwood gravelly sandy loam 6 to 15 percent slopes (EwC)
- Everett gravelly sandy loam 5 to 15 percent slopes (EvC)
- Norma sandy loam (No)
- Seattle muck (Sk)
- Snohomish silt loam (So)
- Tukwila muck (Tu)
- Urban land (Ur)

The primary constituent soil series within the Project area include Alderwood gravelly sandy loam, Arents - Alderwood material, Everett-Alderwood gravelly sandy loam, Everett gravelly sandy loam, and urban land. According to the *Hydric Soil List for Washington State* (USDA 2013b), Bellingham silt loam, Norma sandy loam, Seattle muck, Snohomish silt loam, and Tukwila muck soils series are classified as hydric soils, while Alderwood gravelly sandy loam, Arents - Alderwood material, Everett gravelly sandy loam, and Everett-Alderwood soil series are not classified as hydric soils. Upland soils in the Project area have been extensively disturbed by roadway construction and maintenance, development, and ditching.

1.3.4 Hydrology

The Project area contains 11 drainage basins within the Cedar/Sammamish Watershed (Water Resource Inventory Area 8 [WRIA 8]) (Ecology 2015 (Figure 1-4)). There are ten basins within the City limits, including the following in order from west to east along the Project alignment: Coal Creek, Beaux Arts, Mercer Slough, Sturtevant Creek, West Tributary, Goff Creek, Kelsey Creek, Valley Creek, and Sears Creek (City of Bellevue 2013b). The first seven basins are located entirely within the City. The Coal Creek basin is located within the city limits of Bellevue and Newcastle as well as unincorporated King County. The Sears Creek basin is located within the city limits of both Bellevue and Redmond, and the Lake Sammamish basin is located within the city limits of Redmond.

Hydrologic characteristics in the Project area are influenced by regional groundwater, direct precipitation, surface water runoff, streams and drainage features. Mercer Slough is the largest water body in the Project area and Lake Washington is located near the southern end of the Project area.

In total, eleven streams were identified and/or delineated within areas of proposed Project construction or are in close proximity to the Project within Bellevue limits. Stream names were established specifically for the Project and are based on common geographic identifiers within the area. A summary of stream channels within the Project area that will be disturbed, or have buffers that will be disturbed, under the proposed Project are discussed in Section 2.3. A complete description of the stream survey and associated figures showing the locations of streams within the Project area are presented in the

Sound Transit East Link Extension Project Wetland, Stream, and Jurisdictional Ditch Delineation Report (Delineation Report; Anchor QEA 2014); maps of these resources are included in Appendix A.

1.3.5 Plant Communities and Habitat

The Project area lies within the western hemlock (*Tsuga heterophylla*) vegetation zone of western Washington (Franklin and Dyrness 1988). Vegetation is dominated by needle-leaved, evergreen tree species, such as Douglas fir (*Pseudotsuga menziesii*), western hemlock, and western red cedar (*Thuja plicata*). Other dominant tree species include red alder (*Alnus rubra*) and big-leaf maple (*Acer macrophyllum*). The western hemlock vegetation zone is a forest climax community and does not necessarily reflect existing vegetation in the Project area, but provides a general description of forested habitat in this region of Puget Sound.

Overall, five vegetation communities were identified within the Project area: mowed and unmowed grassland areas; shrubland; mixed deciduous/coniferous forest; commercial and residential areas containing a fragmented mixture of native, nonnative, and ornamental plant species; and wetlands. Generally, tree species occur in scattered patches and upland areas, including areas adjacent to the existing roadway, residential and commercial properties, and disturbed areas. Vegetation in the ROW upland areas includes species typically associated with human disturbance and past land-clearing activities. The largest forested habitat areas within and near the Project area are the habitat areas associated with the Mercer Slough. A complete description of vegetation in the Project area is presented in Section 2.1.2.

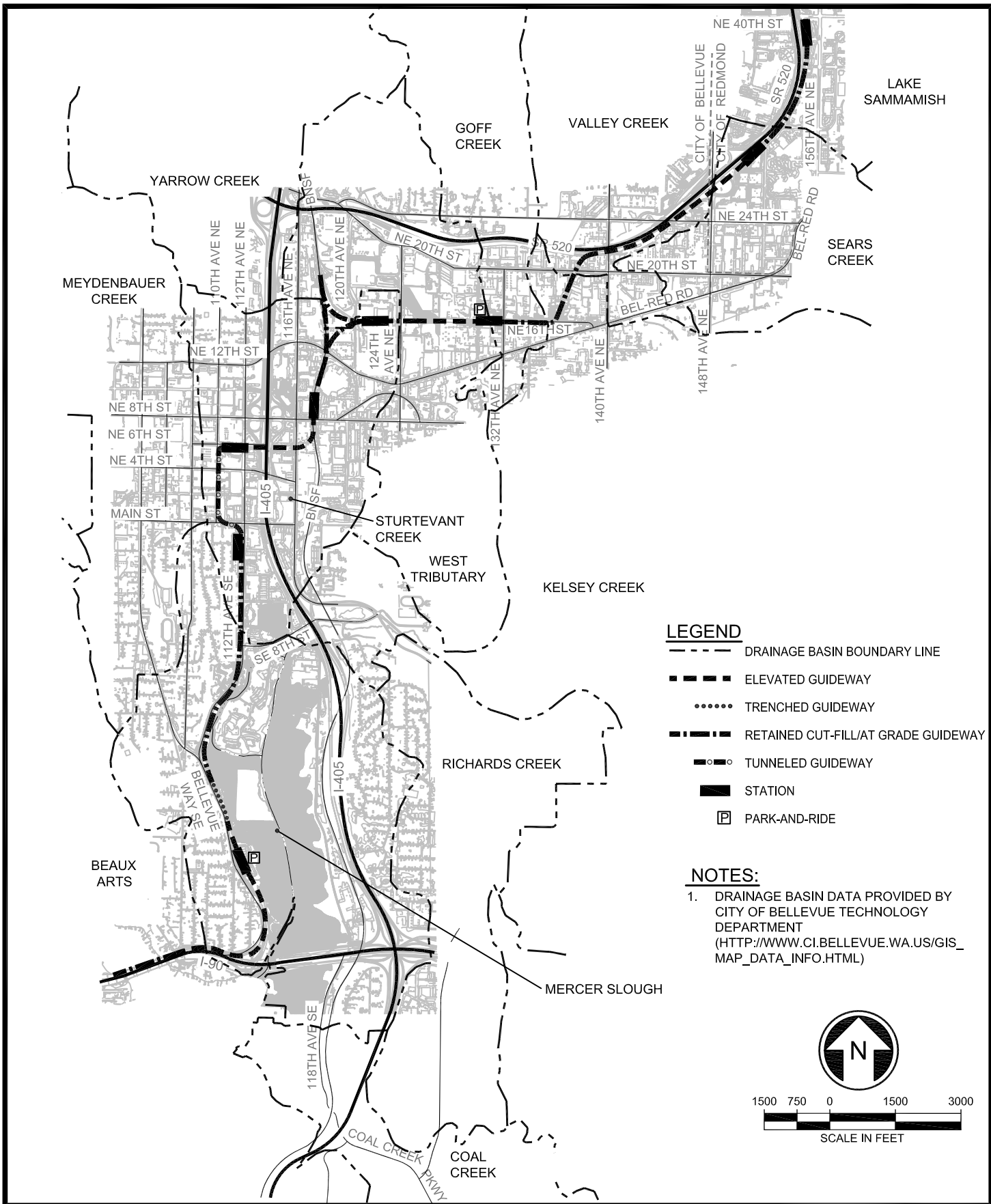

05/07/15 | 12:10 PM | JLOGAN J:\55229\CADD\5001\DRAWINGS\ARCH\CRITICAL AREAS REPORT\REPORT FIGURES\CAR1-4.DWG



EAST LINK EXTENSION
SOUTH BELLEVUE TO OVERLAKE TRANSIT CENTER
FIGURE 1-4
CITY OF BELLEVUE
DRAINAGE BASIN BOUNDARIES

The *USFWS Wetlands Mapper for NWI Map Information* identifies Palustrine aquatic bed (PAB), Palustrine emergent (PEM), Palustrine scrub-shrub (PSS), and Palustrine forest (PFO) wetland systems within and in the vicinity of the Project area (USFWS 2013). WDFW Priority Habitats and Species (PHS) maps identify wetland habitat in the same area as the NWI maps (WDFW 2013a).

In total, 21 wetlands were identified and/or delineated within areas along the proposed Project corridor or that are in close proximity to the Project and within City limits. There are six additional wetlands located within the off-site stream enhancement mitigation site on Coal Creek. One of those wetlands, Wetland D, will be affected by the mitigation action. Wetland D was identified by others for a City of Bellevue project and verified by Sound Transit staff. With the exception to Wetland D, wetland names were typically established for the Project and are based on common geographic identifiers within the area. A summary of wetlands and wetland buffers within the Project area that will be disturbed under the proposed Project are discussed in Section 2.2. A complete description of the wetland delineation results and associated figures are presented in the Delineation Report (Anchor QEA 2014); maps of these resources are included in Appendix A. Additional information about Wetland D is also provided in Appendix A. Detailed information about Wetland D is also available in the *Lower Coal Creek Sediment Pond Critical Areas Report* (David Evans and Associates 2007).

1.4 Project Compliance with City Code Performance Standards and Criteria

The preparation of this CAR included an evaluation of the BCC requirements for the development of light rail facilities and associated critical areas review and reporting. A summary of these code requirements and how the analyses contained within this report meet the requirements is summarized here.

1.4.1 Consistency with Light Rail Overlay District (Chapter 20.25M LUC)

In February 2013, the City passed Ordinance 6101, which amended the LUC to “allow for the permitting and review of Light Rail Facilities and Systems,” and created a Light Rail Overlay District (Chapter 20.25M LUC). Under Ordinance 6101, the provisions of the Critical Areas Overlay District (LUC 25.25H) are incorporated by reference into the new Light Rail Overlay District. At the same time, the City also passed Ordinance 6102, to provide consistency between the new Light Rail Overlay and existing land use code. Ordinance 6102 includes an amendment to LUC.20.25H.055.B that specifically identifies Regional Light Rail Transit (RLRT) Facilities as Essential Public Facilities that are regulated by Part 20.25M. The methodology and analyses contained within this CAR are consistent with the standards established for the Light Rail Overlay District and with the corresponding critical areas allowances.

The provisions of Ordinance 6101 include LUC 20.25M.030.C.3, which defines the requirements for a consolidated permitting process for light rail facilities—Design and Mitigation Review. These requirements include specific measures for proposed RLRT Facility that “will be located, in whole or in part, in a critical area regulated by Part 20.25H LUC.” These requirements (LUC 20.25.M.030.3.j) include the measure that such a facility shall satisfy the following additional criteria.

- i. *The proposal utilizes, to the maximum extent possible, the best available construction, design, and development techniques, which result in the least impact on the critical area and critical area buffer;*

Demonstration of Meeting Criteria: Sound Transit completed a lengthy environmental review process, which served to avoid and minimize impacts to critical areas throughout the alignment. During design, further efforts were made to adjust the light rail alignment and positioning of features such as the guideway columns to avoid wetlands and streams and their buffers. The resulting impacts from the Project (less than 1 acre) represent the maximum extent of avoiding impacts to critical areas.

- ii. *The proposal incorporates the performance standards of Part 20.25H LUC to the maximum extent applicable; and*

Demonstration of Meeting Criteria: Achievement of these performance standards to the maximum extent possible is discussed in Section 1.4.2.

- iii. *The proposal includes a mitigation or restoration plan consistent with the requirements of LUC 20.25H.210; except that a proposal to modify or remove vegetation pursuant to an approved Vegetation Management Plan under LUC 20.25H.055.C.3.i shall not require a mitigation or restoration plan.*

Demonstration of Meeting Criteria: The Project includes a mitigation plan, contained within this report.

1.4.2 Performance Standards

In accordance with LUC 20.25H.055.B, projects within a critical area or its buffer must meet all applicable performance standards. The performance standards applicable to the Project are identified in Table 1-1 and discussed in the following sections.

Table 1-1 City of Bellevue Performance Standards for Proposed Elements of Light Rail Project in Critical Areas

Improvement	Performance Standards			
	Wetlands	Streams	Geologic Hazard Areas	Areas of Special Flood Hazard
New or expanded essential public facilities	20.25H.055.C.2; 20.25H.100	20.25H.055.C.2; 20.25H.080.A; 20.25H.080.B	20.25H.055.C.2; 20.25H.125	20.25H.055.C.2; 20.25H.180.C; 20.25H.180.D.3

1.4.3 LUC 20.25H.055.C.2

The Project, which includes its associated mitigation, is an Essential Public Facility, as defined by 20.25M.020.D and 20.25M.020.E, which include Regional Light Rail Transit Facilities and Systems as Essential Public Facilities. The performance standards of 20.25H.055C.2 ordinarily require an applicant who proposes to do work in a critical area to demonstrate that there is “no technically feasible alternative with less impact on the critical area or critical area buffer.” However, this performance

standard does not apply to this application because Chapter 20.25M LUC states in LUC 20.25M.040.1.2 that, “[a] regional transit authority is not required to demonstrate that no technically feasible alignment or location alternative with less impact exists for any RLRT Facility, provided that the alignment location and profile of the RLRT System or Facility use has been approved by the City Council pursuant to an adopted resolution...” The City Council approved the alignment on April 22, 2013 in Resolution No. 8576.

1.4.4 LUC 20.25H.080.A and LUC 20.25H.080.B

The proposed Project meets the performance standard described in LUC 20.25H.080, which reads as follows for development in certain streams:

Development on sites with a Type S or Type F stream or associated critical area buffer shall incorporate the following performance standards in design of the development, as applicable:

A. General.

1. Lights shall be directed away from the stream.

Performance Standard Achievement: Five streams that will be impacted by the Project meet the condition of this standard: Wye Creek (Type F), Alcove Creek (Type F), Sturtevant Creek (Type F), the West Tributary to Kelsey Creek (Type F) and Goff Creek (Type F). Light features will be directed away from streams, with the exception of areas that require illumination to address public safety concerns. Minimization efforts, such as shielding or reduced footcandles, will be implemented where possible.

2. Activity that generates noise such as parking lots, generators, and residential uses shall be located away from the stream or any noise shall be minimized through use of design and insulation techniques.

Performance Standard Achievement: The proposed operational improvements that would impact the Type F and Type S streams are anticipated to have minimal impacts to aquatic habitat. Care has been taken during design to avoid and minimize impacts to these streams by locating facilities away from streams and implementing mitigation measures where possible.

3. Toxic runoff from new impervious area shall be routed away from the stream.

Performance Standard Achievement: Any toxic runoff from new impervious areas will be collected and routed away from the Type F and Type S streams.

4. Treated water may be allowed to enter the stream critical area buffer.

Performance Standard Achievement: Water will be treated before entering into Type F or Type S stream buffers or routed away from Type F and Type S streams and their associated buffers.

5. The outer edge of the stream critical area buffer shall be planted with dense vegetation to limit pet or human use.

Performance Standard Achievement: All planted buffer areas that are adjacent to areas that can be accessed by the public will be densely planted with thorny species and/or fenced off with signage.

6. Use of pesticides, insecticides and fertilizers within 150 feet of the edge of the stream critical area buffer shall be in accordance with the City of Bellevue’s “Environmental Best Management Practices,” now or as hereafter amended.

Performance Standard Achievement: Use of pesticides, insecticides, and fertilizers within 150 feet of the edge of the stream critical area buffer will be in accordance with the City of Bellevue’s “Environmental Best Management Practices,” now or as amended in the future.

B. Modification of Stream Channel.

1. When Allowed. A stream channel shall not be modified by relocating the open channel, or by closing the channel through pipes or culverts unless in connection with the following uses allowed under LUC 20.25H.055:
 - a. A new or expanded utility facility or system;
 - b. A new or expanded essential public facility;
 - c. Public flood control measures;
 - d. In-stream structures;
 - e. New or expanded public ROW, private roads, access easements or driveways;
 - f. Habitat improvement project; or
 - g. Reasonable use exception, provided that a modification may be allowed under this section for a reasonable use exception only where the applicant demonstrates that no other alternative exists to achieve the allowed development.

Performance Standard Achievement: The Project is a new essential public facility, and therefore meets this performance standard under B.1.b. above.

A critical areas report may not be used to modify the uses set forth in this subsection B.1.

2. Critical Areas Report Required. Any proposal to modify a stream channel under this section may be approved only through a critical areas report.

Performance Standard Achievement: The Project will require the relocation of Sturtevant Creek and Wye Creek, and this Critical Areas Report has been prepared to support the approval of the relocation design. The relocation will provide an overall improvement in ecological function of Sturtevant Creek as demonstrated in Section 3.2.2 of this report. Wye Creek will also be relocated, and a small segment will be daylighted, which will provide an overall improvement to the ecological function. The Project will also require the rerouting of Unnamed Tributary to Kelsey Creek, and this CAR has been prepared to support the approval of the design. The rerouting will maintain existing hydrologic functions, and mitigation for impacts will be addressed at sites on the West Tributary to Kelsey Creek and Coal Creek.

This mitigation will provide improvements over existing conditions. Further discussion of the proposed mitigation and resulting ecological improvements is provided in Sections 3.2.3 and 3.2.4 of this report.

3. Relocation of Closed Stream Channel. Any proposal to relocate an existing closed stream channel may be approved only through a critical areas report. (Ord. 5680, 6-26-06, § 3)

Performance Standard Achievement: The project will require the relocation of existing closed stream channels in order to accommodate infrastructure related to the guideway. The relocation will maintain existing hydrologic functions.

1.4.5 LUC 20.25H.100

The proposed Project meets the performance standard described in LUC 20.25H.100, which reads as follows for Development on Sites with a wetland or wetland critical area buffer:

- A. Development on sites with a wetland or wetland critical areas buffer shall incorporate the following performance standards in design of the development, as applicable: Lights shall be directed away from the wetland.

Performance Standard Achievement: Light features will be directed away from wetlands, with the exception of areas that require illumination to address public safety concerns. Minimization efforts, such as shielding or reduced footcandles, will be implemented where possible.

Performance Standard Achievement: The proposed operational improvements that would impact the wetlands are anticipated to have minimal impacts. Care has been taken during design to avoid and minimize impacts to wetlands by locating facilities away from wetlands and implementing mitigation measures where possible.

- B. Toxic runoff from new impervious area shall be routed away from the wetlands.

Performance Standard Achievement: Any toxic runoff from new impervious surfaces will be routed away from the wetlands within the Project corridor.

- C. Treated water may be allowed to enter the wetland critical area buffer.

Performance Standard Achievement: Water will be treated before entering into wetland buffers, or routed away from wetlands and their associated buffers, if it is not needed to maintain hydrologic functions.

- D. The outer edge of the wetland critical area buffer shall be planted with dense vegetation to limit pet or human use.

Performance Standard Achievement: All planted buffer areas that are adjacent to areas that can be accessed by the public will be densely planted with thorny species and/or fenced off with signage.

- E. Use of pesticides, insecticides and fertilizers within 150 feet of the edge of the stream (SIC) buffer be in accordance with the City of Bellevue’s “Environmental Best Management Practices,” now or as hereafter amended (Ord. 5680, 6-26-06, § 3).

Performance Standard Achievement: Use of pesticides, insecticides and fertilizers within 150 feet of the edge of the wetland critical area buffers shall be in accordance with the City of Bellevue’s “Environmental Best Management Practices,” now or as amended in the future.

1.4.6 LUC 20.25H.125

The proposed Project meets the performance standard described in LUC 20.25H.125, which reads as follows regarding landslide hazards and steep slopes:

In addition to generally applicable performance standards set forth in LUC 20.25H.055 and 20.25H.065, development within a landslide hazard or steep slope critical area or the critical area buffers of such hazards shall incorporate the following additional performance standards in design of the development, as applicable. The requirement for long-term slope stability shall exclude designs that require regular and periodic maintenance to maintain their level of function.

- A. Structures and improvements shall minimize alterations to the natural contour of the slope, and foundations shall be tiered where possible to conform to existing topography;

Performance Standard Achievement: Elevated track segments will maintain existing slope contours at columns’ locations, where possible. At-grade track segments between 130th Avenue NE and NE 20th Street will conform to existing street grades. Required track grade separations for maintaining access to the historic Winters House and for street crossings of 112th Avenue SE, 120th Avenue NE, and 124th Avenue NE will require topography modifications. Retaining walls and slopes minimize the Project footprint and extent of topography modification.

- B. Structures and improvements shall be located to preserve the most critical portion of the site and its natural landforms and vegetation;

Performance Standard Achievement: Improvements in steep slopes and structure setbacks have been located to minimize impacts to wetland and stream critical areas. There is no ability to modify locations. Retaining walls and slopes are designed to match existing topography and minimize disturbance to natural landforms and vegetation. The proposed development shall not result in greater risk or a need for increased buffers on neighboring properties;

Performance Standard Achievement: Structure design in steep slope areas, buffers, and structure setbacks is based on geotechnical analyses and recommendations that avoid risk to the light rail transit facilities, users, and neighboring properties. Geotechnical analyses are available upon request as a separate report.

- C. The use of retaining walls that allow the maintenance of existing natural slope area is preferred over graded artificial slopes where graded slopes would result in increased disturbance as compared to use of retaining wall;

Performance Standard Achievement: Retaining walls are used in proximity to critical areas to minimize Project footprint, slope modification, and disturbance to adjacent properties.

- D. Development shall be designed to minimize impervious surfaces within the critical area and critical area buffer;

Performance Standard Achievement: Project impervious surfaces are minimized. All retained cut track sections on steep slopes or buffers have track and retaining wall underdrains.

- E. Where change in grade outside the building footprint is necessary, the site retention system should be stepped and regrading should be designed to minimize topographic modification. On slopes in excess of 40 percent, grading for yard area may be disallowed where inconsistent with this criteria;

Performance Standard Achievement: This condition is not generally relevant to the elevated, at-grade, and retained cut and fill track sections. The East Main, Hospital, and 120th Avenue Stations are built to property lines and do not have these conditions. Site grading for the South Bellevue Station and parking structure and the 130th Avenue Station and surface parking is designed to minimize topographic modification.

- F. Building foundation walls shall be utilized as retaining walls rather than rockeries or retaining structures built separately and away from the building wherever feasible. Freestanding retaining devices are only permitted when they cannot be designed as structural elements of the building foundation;

Performance Standard Achievement: Retaining walls are integral with transit guideway and station components.

- G. On slopes in excess of 40 percent, use of pole-type construction that conforms to the existing topography is required where feasible. If pole-type construction is not technically feasible, the structure must be tiered to conform to the existing topography and to minimize topographic modification;

Performance Standard Achievement: Pole-type construction is not appropriate for the transit guideway construction located on and over steep slopes. The Project has been designed to minimize topographic modification.

- H. On slopes in excess of 40 percent, piled deck support structures are required where technically feasible for parking or garages over fill-based construction types; and

Performance Standard Achievement: The Project does not include any parking areas or garages on slopes in excess of 40 percent.

- I. Areas of new permanent disturbance and all areas of temporary disturbance shall be mitigated and/or restored pursuant to a mitigation and restoration plan meeting the requirements of LUC 20.25H.210 (Ord. 5680, 6-26-06, § 3).

Performance Standard Achievement: The mitigation and monitoring additional provisions for steep slopes required by 20.25H.135 will be met by the contract plans and specifications, including but not limited to temporary erosion and sediment control, drainage, and landscape site restoration, as well as by monitoring of discharges to surface waters.

Measures to be taken to provide long-term stabilization of steep slopes include the installation of soil nails within areas surrounding guideway columns to prevent erosion and scouring and assist in protection against landslides triggered by seismic activity. These techniques are proposed within a wetland buffer as an alternative to fill slopes that would extend into and impact adjacent wetlands. More information can be found within the geotechnical recommendations reports.

Retaining walls within areas adjacent to existing wetlands are also proposed as a means to protect high-quality critical areas and associated habitat.

1.4.7 LUC 20.25H.145

The proposed Project meets the performance standard described in LUC 20.25H.145, which reads as follows regarding Geologic Hazard Areas:

Modifications to geologic hazard critical areas and critical area buffers shall only be approved if the Director determines that the modification:

- A. Will not increase the threat of the geological hazard to adjacent properties over conditions that would exist if the provisions of this part were not modified;

Performance Standard Achievement: Retaining walls and slopes minimize the Project footprint and extent of topography modification. Structure design in steep slope areas, buffers, and structure setbacks is based on geotechnical analyses and recommendations.

- B. Will not adversely impact other critical areas;

Performance Standard Achievement: The Project will avoid and minimize impacts to all critical areas within the City of Bellevue. Unavoidable impacts will be mitigated through restoration, enhancement, and/ or creation of similar resources. Appropriate standards for mitigation, including ratios, monitoring, and other assurances will ensure no net adverse impacts to other critical areas.

- C. Is designed so that the hazard to the project is eliminated or mitigated to a level equal to or less than would exist if the provisions of this part were not modified;

Performance Standard Achievement: Structures related to the Project in steep slope areas, buffers, and structures setbacks are based on geotechnical analyses and recommendations that avoid risk to the proposed light rail transit facilities, users, and neighboring properties.

D. Is certified as safe as designed and under anticipated conditions by a qualified engineer or geologist, licensed in the State of Washington;

Performance Standard Achievement: All portions of the Project design will be designed under the supervision of qualified personnel. The portions of the Project that affect steep slope areas, buffers, and structures setbacks will be designed and approved (i.e., signed and stamped) by a qualified Engineer and/or Geologist.

E. The applicant provides a geotechnical report prepared by a qualified professional demonstrating that modification of the critical area or critical area buffer will have no adverse impacts on stability of any adjacent slopes, and will not impact stability of any existing structures. Geotechnical reporting standards shall comply with requirements developed by the Director in City of Bellevue Submittal Requirements Sheet 25, Geotechnical Report and Stability Analysis Requirements, now or as hereafter amended;

Performance Standard Achievement: A Geotechnical Recommendations Report written by a qualified professional will be available that contains information on the geologic characterization, geologic hazards, geologic profiles and cross sections, geologic unit distribution, and hydrogeologic interpretation.

F. Any modification complies with recommendations of the geotechnical support [sic] with respect to best management practices, construction techniques or other recommendations; and

Performance Standard Achievement: The Contractor will be required to follow all Geotechnical recommendations contained in the Geotechnical Recommendations Report, including best management practices, construction techniques, and other recommendations.

G. The proposed modification to the critical area or critical area buffer with any associated mitigation does not significantly impact habitat associated with species of local importance, or such habitat that could reasonably be expected to exist during the anticipated life of the development proposal if the area were regulated under this part. (Ord. 5680, 6-26-06, § 3)

Performance Standard Achievement: The City of Bellevue lists 23 species of local importance. Nineteen of these are potentially in the project area and include two amphibian, eight bird, four fish, four mammal, and one reptile species. There are a total of nine steep slope areas or slope

buffers along the project corridor that are potentially suitable habitat for species of local importance. Specific discussion of measures to avoid, minimize and mitigate for potential impacts to these habitats are included in Section 2.6.1 of this report.

1.4.8 LUC 20.25H.180.C

The proposed Project meets the performance standard described in LUC 20.25H.180.C, which reads as follows regarding Special Flood Hazard Areas:

C. General Performance Standards

Where use or development is allowed pursuant to LUC 20.25H.055 (*See Table 1-1*), the following general performance standards apply:

1. Intrusion Over the Area of Special Flood Hazard Allowed. Any structure may intrude over the area of special flood hazard if:
 - a. The intrusion is located above existing grade, and does not alter the configuration of the area of special flood hazard;
 - b. The intrusion is at an elevation and orientation which maintains the existing vegetation of the area of special flood hazard in a healthy condition. Solar access to vegetation must be maintained at least 50 percent of daylight hours during the normal growing season; and
 - c. The intrusion does not encroach into the regulated floodway except in compliance with subsection C.5 of this section.

Performance Standard Achievement: The guideway crosses over the existing grades of areas of special flood hazard, just north of the Hospital Station to the east of Lake Bellevue, and near Valley Creek, just southeast of the intersection of 140th Avenue NE and SR 520. In both areas, the guideway is elevated with columns that are not located within the floodplains, and that are at a sufficient height and orientation to maintain the existing vegetation in a healthy condition. The existing vegetation will be maintained where possible, but may be altered due to the need to replace vegetation for safety concerns and the need to replace invasive species with native species. In both areas, solar access to vegetation will be maintained at least 50 percent of daylight hours during the normal growing season.

Development not meeting the requirements of this subsection C.1 may be allowed pursuant to LUC 20.25H.055 and only in accordance with the requirements set forth in the remainder of this section C.

2. Elevation Certificate Following Construction. Following construction of a structure within the area of special flood hazard, where the base flood elevation is provided, the applicant shall obtain an elevation certificate. The elevation certificate shall be completed by a surveyor licensed in the state of Washington and shall be submitted to City of Bellevue, Utilities Department. The Director shall obtain and transmit to the

Director of the Utilities Department the elevation in relation to City of Bellevue vertical datum (North American Vertical Datum 1988) of the lowest floor, including basement, and attendant utilities of a new or substantially improved structure permitted by this part. All records shall be maintained for public inspection in accordance with 44 Code of Federal Regulations 60.3(b)(5)(iii) and the City of Bellevue record retention policy.

Performance Standard Achievement: No structures are planned to be located within areas of special flood hazard relating to this Project.

3. Construction Materials and Methods.

- a. Site Design. All structures, utilities, and other improvements shall be located on the buildable portion of the site out of the area of special flood hazard unless there is no buildable site out of the area of special flood hazard. For sites with no buildable area out of the area of special flood hazard, structures, utilities, and other improvements shall be placed on the highest land on the site, oriented parallel to flow rather than perpendicular, and sited as far from the stream and other critical areas as possible. Located in flood-fringe where flood flow velocities are less than three feet per second and flood depths are less than three feet. If the Director detects any evidence of active hyporheic exchange on a site, the development shall be located to minimize disruption of such exchange.

Performance Standard Achievement: Improvements are proposed within the Sweyolocken mitigation site, which is partially located within the 100-year floodplain of Mercer Slough. These improvements would not interfere with the function of an area of special flood hazard or require a buildable site. Currently, approximately 7 acres of wetland enhancement/rehabilitation are proposed at this site, and it is estimated that 3 acres are within the 100-year floodplain. Project demands led to using this site for mitigation because there are limited mitigation sites within the City of Bellevue. The nature of the wetland enhancement/rehabilitation work involves some minor grading activities, but presents little opportunity to place improvements on the highest land on the site, orient improvements parallel to the flow, or locate improvements away from streams or other critical areas. However, if Project mitigation needs are reduced, reductions will occur within the 100-year floodplain areas first.

- b. Methods That Minimize Flood Damage. All new construction and substantial improvements shall be constructed using flood-resistant materials and using methods and practices that minimize flood damage.

Performance Standard Achievement: Flood waters entering into the Sweyolocken mitigation site are not anticipated to create any damage to the improvements.

- c. Utility Protection. Electrical, heating, ventilation, plumbing, air-conditioning equipment, and other service facilities shall be designed and/or otherwise elevated or located so as to prevent water from entering or accumulating within the components during conditions of flooding.

Performance Standard Achievement: No utilities or service facilities that are associated with the Project are proposed to be located within at-grade areas of special flood hazard.

- d. Anchoring. All new construction and substantial improvements shall be anchored to prevent flotation, collapse, or lateral movement of the structure.

Performance Standard Achievement: A majority of the habitat features within the Sweyolocken mitigation site will be located outside of the 100-year floodplain. No Rise in the Base Flood Elevation (BFE). Any allowed use or development shall not result in a rise in the BFE.

- a. Post and Pile. Post and piling techniques are preferred and are presumed to produce no increase in the BFE. Demonstration of no net rise in the BFE through calculation is not required.
- b. Compensatory Storage. Proposals using compensatory storage techniques to assure no rise in the BFE shall demonstrate no net rise in the BFE through the calculation by methods established in the Utilities Storm and Surface Water Engineering Standards, January 2011, Section D4-04.5, Floodplain/Floodway Analysis, now or as hereafter amended.

Performance Standard Achievement: Earthwork improvements within the Sweyolocken mitigation site that are within the 100-year floodplain will be balanced, meaning there will be no rise in the BFE. This will be shown using the calculation methods established in the Utilities Storm and Surface Water Engineering Standards mentioned above.

4. Development in the Regulatory Floodway.
 - a. Encroachment into Regulatory Floodway Prohibited. Encroachments, including, but not limited to, fill, new construction, substantial improvements, and other development, are prohibited, unless a registered professional engineer certifies that the proposed encroachment into the regulatory floodway shall not result in any rise in the BFE using hydrological and hydraulic analysis performed in accordance with City of Bellevue Storm and Surface Water Engineering Standards, January 2011, or as hereafter amended. All new construction and substantial improvements shall comply with this section.

Performance Standard Achievement: The Sweyolocken mitigation site is a habitat improvement project and is not considered to be substantial or an encroachment into the regulatory floodway.

- b. Residential Structures. A residential structure located partially within the regulatory floodway will be considered as totally within the regulatory floodway and must comply with this subsection C.5. This subsection does not apply to structures identified as historical places. Construction or reconstruction of residential structures is prohibited within the regulatory floodway, except when:

- i. Repairs, reconstruction, or improvements to a structure do not increase the footprint; and
- ii. Repairs, reconstruction, or improvements to a structure, the cost of which does not exceed 50 percent of the market value of the structure either (1) before the repair, reconstruction, or improvement is begun, or (2) if the structure has been damaged, and is being restored, before the damage occurred. Work done to comply with state or local health, sanitary, or safety codes identified by the Building Official and which are the minimum necessary to assure safe living conditions or any alteration of a structure listed on the National Register of Historic Places shall not be included in the 50 percent market value determination.

Performance Standard Achievement: Residential structures are not included in this Project

- c. Substantially Damaged Residential Structures.
 - i. The Director may request the Washington State Department of Ecology (Ecology) assess the risk of harm to life and property posed by the specific conditions of the regulatory floodway, and provide the City with a recommendation on repair or replacement of a substantially damaged residential structure consistent with Washington Administrative Code (WAC) 173-158-076, now or as hereafter amended. Property owners shall be responsible for submitting to the City any information necessary to complete the assessment when such information is not otherwise available. No repair or replacement of a substantially damaged residential structure located in the regulatory floodway is allowed without a recommendation from Ecology.
 - ii. Before the repair, replacement, or reconstruction is started, all requirements of this section must be satisfied. In addition, the following conditions shall be met:
 - (1) There is no potential safe building location for the replacement residential structure on the same property outside the regulatory floodway;
 - (2) A replacement residential structure is a residential structure built as a substitute for a previously existing residential structure of equivalent use and size;
 - (3) Repairs or reconstruction or replacement of a residential structure shall not increase the total square footage of floodway encroachment;

- (4) The elevation of the lowest floor of the substantially damaged or replacement residential structure is a minimum of 1 foot higher than the base flood elevation;
- (5) New and replacement water supply systems are designed to eliminate or minimize infiltration of flood water into the system;
- (6) New and replacement sanitary sewerage systems are designed and located to eliminate or minimize infiltration of flood water into the system and discharge from the system into the flood waters; and
- (7) All other utilities and connections to public utilities are designed, constructed, and located to eliminate or minimize flood damage.

Performance Standard Achievement: Repair or replacement of residential structures is not included in this Project.

5. Modification of Stream Channel. Alteration of open stream channels shall be avoided, if feasible. If unavoidable, the following provisions shall apply to the alteration:
 - a. Modifications shall only be allowed in accordance with the habitat improvement projects.
 - b. Modification projects shall not result in blockage of side channels.
 - c. The City of Bellevue shall notify adjacent communities, Ecology and WDFW, and the Federal Insurance Administration about the proposed modification at least 30 days prior to permit issuance.
 - d. The applicant shall maintain the altered or relocated portion of the stream channel to ensure that the flood-carrying capacity is not diminished. Maintenance shall be bonded for a period of 5 years, and be in accordance with an approved maintenance program.

Performance Standard Achievement: None of the stream channels located within areas of special flood hazard will have modifications.

6. Compensatory Storage. Development proposals must not reduce the effective base flood storage volume of the area of special flood hazard. Grading or other activity that would reduce the effective storage volume must be mitigated by creating compensatory storage on the site. The compensatory storage must:
 - a. Provide equivalent elevations to that being displaced;
 - b. Be hydraulically connected to the source of flooding;
 - c. Be provided in the same construction season and before the flood season begins on September 30th;

- d. Occur on site or off site if legal arrangements can be made to assure that the effective compensatory storage volume will be preserved over time;
- e. Be supported by a detailed hydraulic analysis that:
 - i. Is prepared by a licensed engineer;
 - ii. Demonstrates that the proposed compensatory storage does not adversely affect the BFE; and
 - iii. Meet all other critical areas rules subject to this part.
- f. If modification to a critical area or critical area buffer is required to complete the compensatory storage requirement, such modification shall be mitigated pursuant to an approved mitigation and restoration plan, LUC 20.25H.210.

Performance Standard Achievement: None of the Project areas will reduce the effective base flood storage volume within areas of special flood hazard. Minor grading activities are proposed at the Swaylocken mitigation site and the Coal Creek mitigation site, but these actions will result in no rise in BFE because all earthwork will be balanced within this area. The FEMA habitat assessment for these two areas is included in this document as Appendix G. The hydraulic effects of the mitigation work on Coal Creek are included in Appendix H.

2.0 Critical Areas Assessment

This section provides a description of critical areas protected under the BCC (City of Bellevue 2013a), including Habitat Associated with Species of Local Importance, Wetlands, Streams, Areas of Special Flood Hazard, and Geologic Hazard. In addition, this section provides a description of Probable Cumulative Impacts associated with the Project.

Shoreline critical area buffers impacted by the Project overlap in all instances with stream and wetland critical area buffers. As such, avoidance, minimization, impacts, and mitigation to shoreline critical area buffers are fully addressed in the discussion of stream and wetland buffers in this document.

2.1 Habitat Associated with Species of Local Importance

This section was prepared based on the submittal requirements identified in LUC 20.25H.250 (City of Bellevue 2013a). Species of local importance are recognized populations of native species that are at risk of being lost from the City.

This section also includes a Habitat Assessment in accordance with LUC 20.25H.165. The habitat assessment is an investigation of the site to evaluate the potential presence or absence of designated species of local importance or habitat for species of local importance. Information in the habitat assessment includes a description of vegetation communities and habitat conditions in the Project area, the identification of species of local importance that occur or could potentially occur in the Project area, and whether site conditions meet the needs of any species of local importance. Also included in the assessment is a summary of the analysis of federally-listed species protected under the Endangered Species Act (ESA), as described in the Biological Assessment (BA) that was prepared for the Project (Axis Environmental, LLC and CH2M HILL 2010).

2.1.1 Methods

To document and describe habitat characteristics within the Project area, existing information was reviewed (Section 1.3.1), an aerial photograph assessment was performed, and site visits were conducted in February, March, April, and May, June, July, and August 2013. During the site visits, general information regarding habitats and dominant plant species and communities was documented while walking through the Project area and performing wetland delineations and tree surveys for the Project. The majority of the Project area was accessible during the investigation, although some property parcels were not accessible due to limited right-of-entry (ROE) authorizations. Wildlife species, tracks, and other signs observed during the site visits were documented. All observations were qualitative; no quantitative wildlife surveys were performed.

2.1.2 Vegetation Communities

The Project area is located within a densely populated urban area of the City that is dominated by commercial and residential development, with the exception of the Mercer Slough Nature Park. As a result, the majority of vegetation communities located within the Project area are fragmented and

associated with road ROWs and residential and commercial development. Mercer Slough Nature Park is a large complex (greater than 350 acres) of wetland and upland habitats associated with the slough and Lake Washington. The park contains a wide variety of emergent, shrub, and forested vegetation communities.

Five general vegetation communities were identified within the Project area: mowed grassland areas, unmowed grassland areas; shrubland; mixed deciduous/coniferous forest; commercial and residential areas containing a fragmented mixture of native, nonnative, and ornamental plant species; and wetlands.

Mowed and unmowed grassland areas are common throughout the Project area. Portions of the Project area that are dominated by grassland habitat include residential and commercial properties and habitat adjacent to City roads and SR 520. Plant species within the grassland habitat includes a variety of native and nonnative grasses and herbaceous species that are common within King County, including Colonial bentgrass (*Agrostis capillaris*), common velvet-grass (*Holcus lanatus*), Kentucky bluegrass (*Poa pratensis*), red fescue (*Festuca rubra*), tall fescue (*Festuca arundinacea*), redtop (*Agrostis gigantea*), reed canarygrass (*Phalaris arundinacea*), common dandelion (*Taraxacum officinale*), English plantain (*Plantago lanceolata*), red clover (*Trifolium pratense*), and white clover (*Trifolium repens*).

Shrubland communities include landscaped vegetation associated with residential and commercial development and roadside and disturbed areas. Native shrub species observed in the Project area include western azalea (*Rhododendron occidentale*), Indian plum (*Oemleria cerasiformis*), red elderberry (*Sambucus racemosa*), salal (*Gaultheria shallon*), snowberry (*Symphoricarpos albus*), beaked hazelnut (*Corylus cornuta*), and salmonberry (*Rubus spectabilis*). Ornamental shrub species include English laurel (*Prunus laurocerasus*), crabapple (*Malus* sp.), and a variety of ornamental hedge species. Several areas adjacent to the roads and development are dominated by the nonnative species Himalayan blackberry (*Rubus armeniacus*).

Mixed deciduous/coniferous forest habitat is primarily fragmented patches associated with road ROW, and commercial and residential development. The only vegetation community in the Project area that includes undisturbed habitat larger than 1 acre and is not fragmented is the habitat near Mercer Slough. A tree survey of all trees in the Project area was performed within areas of potential disturbances. Native tree species observed within the Project area include big-leaf maple, Douglas fir, red alder, western hemlock, western red cedar, paper birch (*Betula papyrifera*), Oregon ash (*Fraxinus latifolia*), and black cottonwood (*Populus trichocarpa*). Ornamental species include Austrian black pine (*Pinus nigra*), crabapple, and cherry (*Prunus* sp.). Many of the shrub species observed in the Project area are present as understory species of the forested vegetation.

Commercial and residential areas contained a mixed and fragmented habitat characterized by interspersed buildings and paving. Vegetation is a heterogeneous mix of deciduous and coniferous trees and groves, interspersed with shrublands, smaller wetlands, and lawn areas. Commercial and residential areas contain a mixture diverse species mix of native, nonnative, and ornamental plant species.

Twenty-one wetland communities were identified within the immediate Project area and an additional six at the Coal Creek mitigation site. These wetlands are all palustrine systems and include open water, emergent, scrub-shrub, and forested wetland systems. A detailed discussion of the wetlands within the project corridor is presented in Section 2.2. Only one wetland (Wetland D) at the Coal Creek mitigation site will be temporarily impacted during mitigation site construction. The remaining five wetlands at the Coal Creek site will not be impacted and are not discussed in detail in this report. Common and scientific names of plant species observed within the Project area are provided in Table 2-1.

Table 2-1 Plant Species Observed within the Project Area

1

Scientific Name	Common Name	Scientific Name	Common Name
Trees		<i>Hedera helix</i>	English ivy
<i>Acer macrophyllum</i>	Big-leaf maple	<i>Holodiscus discolor</i>	Oceanspray
<i>Abies grandis</i>	Grand fir	<i>Ilex aquifolium</i>	Holly
<i>Alnus rubra</i>	Red alder	<i>Kalmia spp.</i>	Laurel
<i>Arbutus menziesii</i>	Pacific madrona	<i>Lonicera involucrate</i>	Twinberry
<i>Betula papyrifera</i>	Paper birch	<i>Mahonia aquifolium</i>	Tall Oregon grape
<i>Crataegus douglasii</i>	Black hawthorn	<i>Mahonia nervosa</i>	Low Oregon grape
<i>Fraxinus latifolia</i>	Oregon ash	<i>Oemleria cerasiformis</i>	Indian plum
<i>Malus domestica</i>	Domestic apple	<i>Oplopanax horridus</i>	Devil's club
<i>Malus Sp.</i>	Crabapple	<i>Polygonum cuspidatum</i>	Japanese knotweed
<i>Physocarpus capitatus</i>	Pacific ninebark	<i>Prunus laurocerasus</i>	English laurel
<i>Picea sitchensis</i>	Sitka spruce	<i>Rhododendron occidentale</i>	Western azalea
<i>Pinus monticola</i>	Western white pine	<i>Rhododendron macrophyllum</i>	Pacific rhododendron
<i>Pinus nigra</i>	Austrian black pine	<i>Ribes bracteosum</i>	Stink currant
<i>Populus tremuloides</i>	Quaking aspen	<i>Ribes lacustre</i>	Prickly currant
<i>Populus trichocarpa</i>	Black cottonwood	<i>Rosa gymnocarpa</i>	Wood rose
<i>Prunus sp.</i>	Cherry	<i>Rosa nutkana</i>	Nootka rose
<i>Prunus emarginata</i>	Bitter cherry	<i>Rubus armeniacus</i>	Himalayan blackberry
<i>Pseudotsuga menziesii</i>	Douglas fir	<i>Rubus laciniatus</i>	Evergreen blackberry
<i>Quercus sp.</i>	Oak	<i>Rubus parviflorus</i>	Western thimbleberry
<i>Rhamnus purshiana</i>	Cascara	<i>Rubus spectabilis</i>	Salmonberry
<i>Salix hookeriana</i>	Hooker willow	<i>Rubus ursinus</i>	Trailing blackberry
<i>Salix lasiandra</i>	Pacific willow	<i>Sambucus racemosa</i>	Red elderberry
<i>Salix scouleriana</i>	Scouler willow	<i>Spiraea douglasii</i>	Spirea
<i>Thuja plicata</i>	Western red cedar	<i>Symphoricarpos albus</i>	Snowberry
<i>Tsuga heterophylla</i>	Western hemlock	<i>Vaccinium ovatum</i>	Evergreen huckleberry
Shrubs		<i>Vaccinium parvifolium</i>	Red huckleberry
<i>Acer circinatum</i>	Vine maple	Grass, Ferns, & Herbaceous	
<i>Cornus nuttallii</i>	Pacific dogwood	<i>Achillea millefolium</i>	Yarrow
<i>Cornus sericea</i>	Red-osier dogwood	<i>Agropyron repens</i>	Quackgrass
<i>Corylus cornuta</i>	Beaked hazelnut	<i>Agrostis capillaris</i>	Colonial bentgrass
<i>Cytisus scoparius</i>	Scot's broom	<i>Agrostis gigantea</i>	Redtop
<i>Gaultheria shallon</i>	Salal	<i>Athyrium filix-femina</i>	Lady fern

Scientific Name	Common Name	Scientific Name	Common Name
<i>Blechnum spicant</i>	Deer fern	<i>Oenanthe sarmentosa</i>	Water-parsley
<i>Brassica campestris</i>	Field mustard	<i>Phalaris arundinacea</i>	Reed canarygrass
<i>Carex deweyana</i>	Dewey sedge	<i>Plantago lanceolata</i>	English plantain
<i>Carex obnupta</i>	Slough sedge	<i>Plantago major</i>	Common plantain
<i>Cirsium arvense</i>	Canadian thistle	<i>Poa pratensis</i>	Kentucky bluegrass
<i>Convolvulus arvensis</i>	Orchard morning glory	<i>Polypodium glycyrrhiza</i>	Licorice fern
<i>Dicentra formosa</i>	Pacific bleeding heart	<i>Polystichum munitum</i>	Sword fern
<i>Digitalis purpurea</i>	Foxglove	<i>Pteridium aquilinum</i>	Bracken fern
<i>Eleocharis palustris</i>	Spike rush	<i>Ranunculus repens</i>	Creeping buttercup
<i>Epilobium angustifolium</i>	Fireweed	<i>Rorippa palustris</i>	Marsh yellowcress
<i>Epilobium watsonii</i>	Watson's willow-herb	<i>Rumex crispus</i>	Curly dock
<i>Equisetum arvense</i>	Field horsetail	<i>Senecio triangularis</i>	Arrowleaf groundsel
<i>Equisetum telmateia</i>	Giant horsetail	<i>Stachys cooleyae</i>	Cooley's hedge-nettle
<i>Festuca arundinacea</i>	Tall fescue	<i>Streptopus amplexifolius</i>	Claspleaf twisted-stalk
<i>Festuca rubra</i>	Red fescue	<i>Tanacetum vulgare</i>	Common tansy
<i>Gallium trifidum</i>	Small bedstraw	<i>Taraxacum officinale</i>	Common dandelion
<i>Geranium robertianum</i>	Stinky bob	<i>Tolmiea menziesii</i>	Piggyback plant
<i>Hedera hibernica</i>	English ivy	<i>Trifolium pratense</i>	Red clover
<i>Holcus lanatus</i>	Common velvet grass	<i>Trifolium repens</i>	White clover
<i>Juncus effusus</i>	Soft rush	<i>Trillium ovatum</i>	Western trillium
<i>Lemna minor</i>	Common duckweed	<i>Typha latifolia</i>	Cattail
<i>Linnaea borealis</i>	Twinflower	<i>Urtica dioica</i>	Stinging nettle
<i>Lysichiton americanus</i>	Skunk cabbage	<i>Verbascum thapsus</i>	Common mullein
<i>Maianthemum dilatatum</i>	False-lily-of-the-valley	<i>Veronica americana</i>	American speedwell
<i>Mentha arvensis</i>	Field mint		

1

2.1.3 Fish and Wildlife Habitat

The mosaic of vegetation communities within the Project area provides habitat for a variety of terrestrial and aquatic wildlife. Wildlife relies on vegetation for food, shelter, and cover from predators. Wildlife diversity is generally related to the structure and composition of plant species within vegetative communities. In general, vegetation communities that contain few species or vegetative layers (herbaceous vegetation, shrubs, or trees) support a low diversity of wildlife, whereas vegetation communities that are more complex and contain a wide variety of plant species and vegetative layers can support a greater diversity of wildlife. Forested and riparian areas with well-developed shrub layers are likely to support the greatest number of species and populations of wildlife (Brown 1985).

Wildlife habitats in the Project area range in quality from low in commercial and residential areas to high in the wetland habitat and forested riparian habitat associated with Mercer Slough. The majority of habitat in the Project area is developed and therefore provides habitat for disturbance-tolerant species typical of urban areas.

Wildlife species typically observed in the Project area include American crow (*Corvus brachyrhynchos*), American robin (*Turdus migratorius*), European starling (*Sturnus vulgaris*), house sparrow (*Passer domesticus*), and eastern gray squirrel (*Sciurus carolinensis*). Habitat associated with the Mercer Slough provides foraging and nesting sites for a variety of native songbird species, small mammals, reptiles, and amphibians. Kelsey West Tributary Pond Wetland is the other notable feature within the Project area that provides diverse foraging and nesting habitat for a variety of wildlife species. This habitat is surrounded by development so the wetland habitat has minimal vegetated buffer and no vegetated corridors connecting the habitat to other undisturbed habitats.

Eleven stream channels were identified within the Project area. Seven of the streams were identified as Type F streams, three were identified as Type N streams, and one was identified as a Type O stream. Similar to wildlife habitat, fish and aquatic habitat in the Project area ranges in quality from low in commercial and residential areas to high in the wetland habitat and forested riparian habitat associated with Mercer Slough and Coal Creek. A detailed discussion of these streams and potential fish use is presented in Section 2.3. Fish use of streams in the Project area is also discussed in Section 2.1.4.

2.1.4 Species of Local Importance

The City recognizes 23 species of local importance (LUC 20.25H.150; City of Bellevue 2013a). As part of the analysis of species of local importance, H-J-H reviewed information from the WDFW PHS database on state priority species and habitats that may occur in or near the Project area (WDFW 2013a). Species of local importance that could occur within the Project area were identified based on observations during the site visits, the WDFW PHS data, the presence of potential suitable habitat for priority species within the Project area, and WDFW management recommendations for priority species (Larsen 1997, Larsen et al. 2004, WDFW 2013a).

Table 2-2 identifies the 23 species of local importance by group (amphibians, birds, mammals, reptiles, and fish), the presence or absence of potential suitable habitat within the Project area, and the state and federal status of each species (LUC 20.25H.150; City of Bellevue 2013a).

Table 2-2 Summary of City of Bellevue Designated Species of Local Importance Potential Presence within the Project Area

Common Name (Scientific Name)	Suitable Habitat	Potential Suitable Habitat Present Within Project Area	State Status	Federal Status
Amphibians				
Oregon spotted frog (<i>Rana pretiosa</i>)	Ponds and lakes with dense emergent vegetation	Yes (Mercer Slough habitat)	Endangered	Candidate
Western toad (<i>Bufo boreas</i>)	Still water in ponds and small lakes	Yes (Mercer Slough habitat)	Candidate	Species of concern
Birds				
Bald eagle (<i>Haliaeetus leucocephalus</i>)	Mature trees near water and prey sources	Yes (Mercer Slough habitat)	Sensitive	Species of concern
Common loon (<i>Gavia immer</i>)	Marine and large lakes and rivers	No (Lake Washington outside Project area)	Sensitive	None
Great blue heron (<i>Ardea herodias</i>)	Fresh and salt-water wetlands, rivers	Yes (Mercer Slough and Kelsey West Tributary Pond Wetland habitat)	Priority	Monitor
Green heron (<i>Butorides striatus</i>)	Fresh water wetlands with forested habitat	Yes (Mercer Slough and Kelsey West Tributary Pond Wetland habitat)	None	None
Merlin (<i>Falco columbarius</i>)	Prairies and conifer forests	Yes (Mercer Slough, habitat and mature trees)	Candidate	None
Osprey (<i>Pandion haliaetus</i>)	Marine coasts, lakes, and rivers	Yes (Mercer Slough and Kelsey West Tributary Pond Wetland habitat)	None	None
Peregrine falcon (<i>Falco peregrinus</i>)	Cliffs and vegetated slopes	No	Sensitive	Species of concern
Pileated woodpecker (<i>Dryocopus pileatus</i>)	Forest with snags and downed wood	Yes (Mercer Slough, Kelsey West Tributary Pond Wetland habitat, and mature trees)	Candidate	None
Purple martin (<i>Progne subis</i>)	Large dead trees or artificial nesting structures near wetlands, ponds, or marine systems	Yes (Mercer Slough, Kelsey West Tributary Pond Wetland habitat, and mature trees)	Candidate	None

Common Name (Scientific Name)	Suitable Habitat	Potential Suitable Habitat Present Within Project Area	State Status	Federal Status
Red-tailed hawk (<i>Buteo jamaicensis</i>)	Open habitat near forests	Yes (Mercer Slough, Kelsey West Tributary Pond Wetland habitat, and mature trees)	None	None
Vaux's swift (<i>Chaetura vauxi</i>)	Old growth forest	No	Candidate	None
Western Grebe (<i>Aechmophorus occidentalis</i>)	Large lakes	No (Lake Washington outside Project area)	Candidate	None
Fish/Salmon				
Bull trout (<i>Salvelinus confluentus</i>)	Marine, rivers, and streams	Yes (Mercer Slough)	Candidate	Threatened
Chinook salmon (<i>Oncorhynchus tshawytscha</i>)	Marine, rivers, and streams	Yes (Mercer Slough)	Candidate	Threatened
Coho salmon (<i>Oncorhynchus kisutch</i>)	Marine, rivers, and streams	Yes (Mercer Slough)	Candidate	Species of concern
River lamprey (<i>Lampetra ayresi</i>)	Rivers and streams	Yes (Mercer Slough)	None	Species of concern
Mammals				
Keen's myotis (<i>Myotis keenii</i>)	Mature coniferous forest	Yes (Mercer Slough, habitat and mature trees)	Candidate	None
Long-eared myotis (<i>Myotis evotis</i>)	Mature coniferous forest	Yes (Mercer Slough, habitat and mature trees)	Monitored	None
Long-legged myotis (<i>Myotis volans</i>)	Mature coniferous forest	Yes (Mercer Slough, habitat and mature trees)	Monitored	None
Western big-eared bat (<i>Plecotus townsendii</i>)	Mature coniferous forest	Yes (Mercer Slough, habitat and mature trees)	None	None
Reptiles				
Western pond turtle (<i>Clemmys marmorata</i>)	Ponds, sloughs, small lakes	Yes (Mercer Slough, habitat)	Endangered	Species of concern

Note:

Sources: City of Bellevue 2013, WDFW 2013, Larsen et al. 1995, Larsen 1997, and Larsen et al. 2004

Five species of local importance were observed during February, March, April, May, June, July, and August 2013 site visits: bald eagle, great blue heron, osprey, pileated woodpecker, and red-tailed hawk. All five of these species were observed in the forested habitat associated with the Mercer Slough adjacent to the Project area and not specifically within the Project area boundary. The WDFW PHS database identifies the following habitats and species of local importance within the vicinity of the Project area (0.2 mile):

- Puget Sound Chinook salmon (*Oncorhynchus tshawytscha*), resident cutthroat trout (*Oncorhynchus clarki*), coho salmon (*Oncorhynchus kisutch*), rainbow trout (*Oncorhynchus mykiss*), and sockeye salmon (*Oncorhynchus nerka*) occurrence and migration are documented in Mercer Slough.
- In addition to these five species, Puget Sound steelhead (*Oncorhynchus mykiss*) and Coastal Puget Sound bull trout (*Salvelinus confluentus*) are documented in Lake Washington south of the Project area.
- Coho salmon occurrence and migration are documented in Mercer Slough near the Project area.
- Bald Eagle breeding areas are located on the east shoreline of Lake Washington, more than 1,000 feet outside the Project area to the west.
- Semipalmated plover (*Charadrius semipalmatus*) was documented in 1993 south of downtown Bellevue, near the Project area. Semipalmated plover does not have state or federal protected status and is not identified by the City of Bellevue as a species of local importance.
- A peregrine falcon (*Falco peregrinus*) breeding area is documented on a building in downtown Bellevue in the area of the Project that will be tunneled beneath downtown.
- As described in Section 2.2, wetlands within the Project area identified on the WDFW PHS database include Mercer Slough Wetland, Lake Bellevue Wetland, and Kelsey West Tributary Pond Wetland.

The Project area is deliberately located through a highly urbanized area to maximize ridership. Of the 23 species identified on the City's species of local importance list, potential suitable habitat for 19 of the species is present within the Project area primarily due to two areas, along the western edge of the Mercer Slough wetland and slough habitat system and the southern edge of the Kelsey West Tributary Pond Wetland habitat. These areas contain open water habitat, forested, shrub, and emergent wetland and upland vegetation communities, and habitat features such as snags for perching, nesting, and foraging. Within these areas, at certain times of the year, bird and bat species of local importance may occupy these habitats for breeding, foraging, or passing through on a migratory route. Amphibian, reptile, and fish species of local importance could potentially occur within the Mercer Slough habitat. Mature trees in the Project area outside of the Mercer Slough habitat could provide habitat for bird and bat species of local importance, although they are limited to isolated and fragmented patches in upland areas on residential or commercial property or in road ROW.

2.1.5 Federally Protected Species and Critical Habitats

A BA was prepared for the Project to evaluate the potential effects on ESA-listed species and critical habitat in compliance with Section 7(a)(2) and Section 3(5)(A) of the ESA (Axis Environmental, LLC and CH2M HILL 2010). Information from the BA is summarized in this report. Table 2-3 presents the federally-listed species identified in the BA as potentially occurring in the Project area. ESA-listed species under National Marine Fisheries Service (NMFS) and USFWS jurisdiction are identified based on the geographic boundaries of Distinct Population Segments (DPSs) and Evolutionary Significant Units (ESUs). The table also identifies whether critical habitat has been designated by NMFS or USFWS for those species within the vicinity of the Project area. Since the BA was submitted in 2010, the ESA listing status of two species (Oregon spotted frog and yellow-billed cuckoo) and critical habitat for three species (Puget Sound steelhead, Oregon spotted frog, and yellow-billed cuckoo) has changed. The change in ESA listing status was addressed in BA supplements prepared for the Project (Anchor QEA 2015a, 2015b).

Table 2-3 Federally Listed and Proposed Species, ESA Status, Critical Habitat, and Effect Determinations

Species	Status	Agency	Effects Determination
Chinook salmon (<i>Oncorhynchus tshawytscha</i>)	Threatened (Puget Sound ESU)	NMFS	NLAA
Chinook salmon Critical Habitat	Designated (Puget Sound ESU)	NMFS	NLAA
Puget Sound steelhead (<i>Oncorhynchus mykiss</i>)	Threatened (Puget Sound DPS)	NMFS	NLAA
Puget Sound steelhead Critical Habitat ¹	Proposed (Puget Sound DPS)	NMFS	NLAA
Bull trout (<i>Salvelinus confluentus</i>)	Threatened (Puget Sound DPS)	USFWS	NLAA
Bull trout Critical Habitat	Designated (Puget Sound DPS)	USFWS	NLAA
Oregon spotted frog (<i>Rana pretiosa</i>) ¹	Threatened	USFWS	NE
Oregon spotted frog Critical Habitat ¹	Designated	USFWS	NE

Species	Status	Agency	Effects Determination
Yellow-billed cuckoo (<i>Coccyzus americanus</i>) ¹	Threatened (Western DPS)	USFWS	NE
Yellow-billed cuckoo Critical Habitat ¹	Designated	USFWS	NE

Notes:

1 Endangered Species Act listing status changed since the 2010 Biological Assessment was submitted.

ESU = Evolutionary Significant Units

DPS = Distinct Population Segment

NLAA=Not Likely to Adversely Affect

NA=Not Applicable

NE=No Effect

NMFS=National Marine Fisheries Service

USFWS=United States Fish and Wildlife Service

Source: Axis Environmental, LLC and CH2M HILL 2010

As shown in Table 2-3, the BA prepared for the proposed Project did not identify the potential presence of terrestrial species in the vicinity of the Project area; fish species and associated critical habitats were the only federally-listed species identified with documented presence in or potential to occur in the Project area. The ESA analysis in the BA concluded that the proposed Project will result in temporary adverse impacts to fish and salmon. However, these impacts are minimized via Project timing and other avoidance and minimization measures. As a result, the BA analysis determined that the proposed Project may affect, but is not likely to adversely affect, Puget Sound Chinook salmon, Puget Sound steelhead, or bull trout or associated critical habitats (Axis Environmental, LLC and CH2M HILL 2010).

According to the BA analysis, Chinook salmon, steelhead, and bull trout have not been documented in the stream systems within the Project area. Chinook salmon and steelhead presence was identified as possibly occurring with the Mercer Slough and Valley Creek systems. In addition, the area of potential Project impacts in the BA analysis included Lake Washington, and Lake Washington is not within the Project area addressed in this report. Critical habitat for Chinook salmon and bull trout includes Lake Washington, but stream systems within the Project area, including Mercer Slough, and Valley Creek, are excluded from the bull trout, Chinook salmon, and steelhead critical habitat designation.

The BA also performed an analysis for Essential Fish Habitat (EFH) consultation with NMFS, in compliance with the Magnuson-Stevens Fishery Conservation and Management Act (Magnuson-Stevens Act). The BA analysis concluded that the proposed Project will have no adverse effect on EFH for salmonid species (Axis Environmental, LLC and CH2M HILL 2010).

2.1.6 Impact Assessment for Habitat Associated with Species of Local Importance

The primary potential construction impact on potential habitat for species of local importance (fish and wildlife habitat, wetlands, streams, and upland vegetation communities) will be removal and loss of habitat. In general, the severity of impact varies depending on the type and quantity of affected

vegetation. For example, losing plant communities that offer limited wildlife habitat, such as fragmented ornamental vegetation in commercial and residential areas, results in less of an adverse effect than losing more complex vegetation associations, such as forested areas and wetlands.

The majority of clearing and grading associated with the Project will include areas with existing impervious surfaces and managed grass and fragmented and isolated tree and shrub vegetation within a densely developed urban area. The majority of the vegetation communities in the Project area is landscaped and does not include understory vegetation that provides habitat for amphibian, bird, reptile, and mammal species. Wildlife species that would likely occupy habitat in these developed areas include birds and small mammals typically associated with urban residential and commercial development.

Potential habitat within the Project area for species of local importance includes Mercer Slough Wetland habitat, the Kelsey West Tributary Pond Wetland habitat, and Coal Creek habitat. The project will impact six steep slope or steep slope buffer areas along Mercer Slough wetland and buffer. The project will impact three steep slope or steep slope buffer areas along the Kelsey West Tributary Pond wetland and buffer. Lake Bellevue provides open water habitat; however, the shoreline of the lake is completely developed, with residential and commercial property including small patches of shoreline vegetation. Potential use by species of local importance is limited to wildlife that are adapted to human activity and disturbances. No impacts to Lake Bellevue are proposed.

With the exception of these systems, wetlands and streams in the Project area lack potential habitat for species of local importance due to their small size and locations adjacent to existing roads and residential and commercial development. The Kelsey West Tributary Pond Wetland is also surrounded by existing roads and development but is a relatively large wetland system, about 6 acres. While mature trees on residential and commercial property provide potential perching habitat for species of local importance, they are less likely to be used for nesting or foraging activity than mature trees within a forested complex.

Impacts to streams and wetlands have been largely avoided as part of the design process (Section 2.6). For the Mercer Slough Wetland complex, 0.17 acre of permanent wetland impacts and 4.10 acres of permanent wetland buffer impacts have been identified. For the Kelsey West Tributary Pond Wetland, 0.01 acre of permanent wetland impacts and 0.13 acre of permanent wetland buffer impacts are anticipated due to the location of the guideway columns in the area. A complete description of wetland and stream impacts is presented in Sections 2.2 and 2.3, respectively.

Disturbances caused by construction may affect wildlife in adjacent habitats by disrupting feeding and nesting activities. Increased noise levels created by heavy machinery could cause birds to abandon their nests and may temporarily displace wildlife during construction. While noise associated with construction activities could result in avoidance behavior by some wildlife species, including species of local importance, wildlife would likely resume use of the site once construction is complete because human disturbance associated with traffic and residential and commercial development has been occurring in the Project area for several decades. As described in the Project ROD, the Federal Transit

Authority concluded that the Project complies with the Migratory Bird Treaty Act and the Bald and Golden Eagle Protection Act for the protection of these birds, and the Project will not improperly affect such birds (FTA 2011).

Operational impacts on wildlife and habitat communities and species of local importance associated with the Project would be minor and related principally to ambient noise levels associated with light rail use in a populated urban area. The Project area has been occupied with roads and residential and commercial development for several decades. Noise levels associated with operation of the light rail after construction are expected to be consistent with current ambient noise levels.

Due to the overall lack of potential habitat for species of local importance within the Project area outside the Mercer Slough, Kelsey West Tributary Pond Wetland, and Coal Creek habitats, the relatively low impact areas of disturbance in critical areas, and the proposed mitigation activities for permanent and temporary impacts (Section 3), overall habitat losses to sensitive areas resulting from the Project are expected to be relatively small and are unlikely to result in a significant impact on native wildlife and species of local importance. Proposed wetland and wetland buffer mitigation measures at the Swayolocken and West Tributary sites will also include incorporating habitat features such as woody debris and tree vegetation that can support species of local importance. Proposed stream and stream buffer mitigation measures will also incorporate measures to improve habitat conditions compared to existing conditions in a populated urban area.

2.2 Wetlands

Wetlands in the Project area were identified and delineated based on the criteria identified in the BCC LUC 20.25H.095 (City of Bellevue 2013a). Wetland locations are shown on Figure 2-1. The results of the wetland survey are presented in the Delineation Report (Anchor QEA 2014). The wetland survey methods and results from that report are summarized in the following sections.

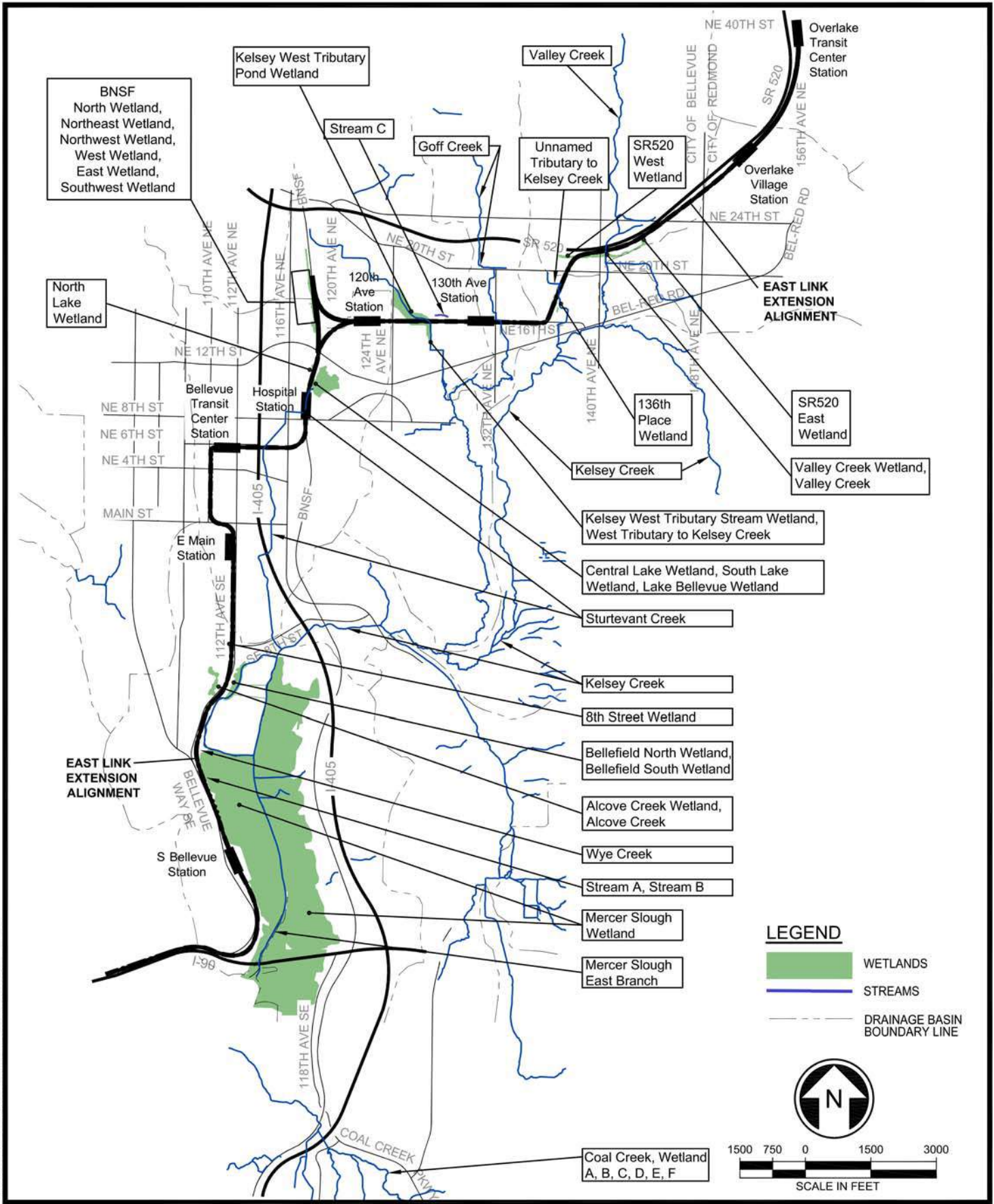

EAST LINK EXTENSION
SOUTH BELLEVUE TO OVERLAKE TRANSIT CENTER
 FIGURE 2-1
 EXISTING WETLANDS AND STREAMS

05/07/15 | 10:26 AM | JLOGAN
 J:\5229\CADD\DS001\DRAWINGS\ARCH\CRITICAL AREAS REPORT\REPORT FIGURES\CAR2-1.DWG



2.2.1 Methods

2.2.1.1. Wetland Delineation

The delineation and rating analysis of wetland habitat in the Project area was performed in February, March, April, and May 2013. The six wetlands associated with the Coal Creek mitigation site were originally delineated in August 2004 by David Evans and Associates. The boundaries of these wetlands were later verified by Sound Transit staff in October 2014. As specified by the BCC (City of Bellevue 2013a), the wetland delineations were conducted based on the methods defined in the *U.S. Army Corps of Engineers Wetland Delineation Manual* (Environmental Laboratory 1987), and the *Regional Supplement to the Corps of Engineers Wetland Delineation Manual: Western Mountains, Valleys, and Coast Region* (Corps 2010). Wetland delineation guidelines identified in Ecology's *Washington State Wetland Identification and Delineation Manual* (Ecology 1997) are based on the information in the *U.S. Army Corps of Engineers Wetland Delineation Manual*.

The U.S. Army Corps of Engineers (Corps) and Ecology method for delineating wetlands is based on the presence of three parameters: hydrophytic vegetation; hydric soils; and wetland hydrology. Vegetation, soils, and hydrology information were collected at sample plots and recorded on field data sheets. Wetland determination data forms from the *Regional Supplement to the Corps of Engineers Wetland Delineation Manual: Western Mountains, Valleys, and Coast Region* (Corps 2010) were recorded for each wetland and associated upland. A complete description of the wetland delineation methods, wetland ratings, and data forms are presented in the Delineation Report (Anchor QEA 2014).

2.2.1.2. Wetland Classifications

Wetland community types were identified according to the USFWS classification developed by Cowardin et al. (1979) for use in the NWI. This system bases the classification of wetlands on their physical characteristics, such as the general type of vegetation in the wetland (e.g., trees, shrubs, grass) and where and how much water is present in the wetland. All wetlands in the Project area are palustrine systems. Palustrine wetlands are inland, nontidal wetlands characterized by the presence of trees, shrubs, and emergent vegetation (vegetation that is rooted below water but grows above the surface). Palustrine wetlands range from permanently saturated or flooded land (as in marshes, swamps, and lake shores) to land that is wet only seasonally. The following wetland community types were identified during the wetland investigation:

- Palustrine forested (PFO) – These wetlands have at least 30 percent cover of woody vegetation that is more than 20 feet high.
- Palustrine scrub-shrub (PSS) – These wetlands have at least 30 percent cover of woody vegetation that is less than 20 feet high.
- Palustrine emergent (PEM) – These wetlands have erect, rooted, herbaceous vegetation present for most of the growing season in most years.
- Palustrine aquatic bed (PAB) – These wetlands are dominated by vegetation that grows principally on or below the surface of the water for most of the growing season in most years.

2.2.1.3. Wetland Ratings and Functions Assessment

At the state level, wetland ratings and functions were determined using the most current version of Ecology guidance in *Washington State Wetlands Rating System for Western Washington: Revised* (Hruby 2004) and *Washington State Wetland Rating Form – Western Washington, Version 2* (Ecology 2008a).

The BCC classifies wetlands into four categories (Categories I, II, III, and IV) based on the adopted Washington State Wetland Rating System for Western Washington, Washington State Department of Ecology (LUC 20.25H.095). Category I wetlands are considered to be the highest functioning, while Category IV wetlands provide the least amount of function. Wetland functions include the ability to improve water quality, attenuate flashy hydrology, and provide habitat.

Using Ecology's rating system, points are awarded to three functional value categories: water quality, hydrologic functions, and wildlife habitat. To determine an accurate assessment of a wetland's functional values, function scores were calculated based on entire wetland systems, when applicable, not just the delineated portion of wetlands.

Washington State Wetland Rating Forms (Ecology 2008a) were recorded for each wetland. Wetland rating forms are included in Appendix E of the Delineation Report (Anchor QEA 2014).

2.2.1.4. State Hydrogeomorphic Classification System

Scientists have come to understand that wetlands can perform functions in different ways. The way a wetland functions depends to a large degree on hydrologic and geomorphic conditions. To recognize these differences among wetlands, a way to group or classify them has been developed. This classification system, called the Hydrogeomorphic (HGM) Classification, groups wetlands into categories based on the geomorphic and hydrologic characteristics that control many functions. The revision to the *Washington State Wetland Rating Form – Western Washington, Version 2* (Ecology 2008a) incorporates the new system as part of the questionnaire for characterizing a wetland's functions. The rating system uses only the highest grouping in the classification (i.e., wetland class). Wetland classes are based on geomorphic settings, such as riverine, slope, or depressional. A classification key is provided within the rating form to help identify which of the following HGM Classifications apply to the wetland: riverine, depressional, slope, lake-fringe, tidal fringe, or flats.

2.2.2 Wetland Study Results

Twenty-one wetlands were identified within the light rail corridor and six wetlands at the Coal Creek mitigation site. One of the Coal Creek wetlands, Wetland D, will be temporarily affected during construction of the stream enhancement and is described below. The other five wetlands at the Coal Creek mitigation site are not described in detail in this section. All wetlands adjacent to the Project are located within the City and are therefore described in this report. The Project alignment has a cumulative length of 7.13 miles and crosses nine drainage basins within the Cedar/Sammamish Watershed (WRIA 8) (Ecology 2015). Wetlands were identified within five of the eight drainage basins within the City (Section 1.3.4; Figure 1-4). A drainage basin map is shown on Figure 1-4. Wetlands are

described in location sequence from west to east. Each wetland was given a descriptive name to reflect its relative location along the alignment. This section provides a summary of the wetlands within the Project area. A complete description of the wetlands and figures noting their locations are presented in the Delineation Report (Anchor QEA 2014). Table 2-4 presents a summary of the wetlands in the Project area, including the approximate wetland size and drainage basin. Table 2-5 presents a summary of the wetlands USFWS classification, hydrogeomorphic classification, state and local ratings, and protective buffer widths, per the BCC (City of Bellevue 2013a).

Table 2-4 Summary of Wetlands Located within the Project Area

Wetland Name	Size ¹ (acres)	Drainage Basin
Mercer Slough	350 ²	Mercer Slough
Alcove Creek	0.23 ³ / 0.64 ²	Mercer Slough
Bellefield South	0.29	Mercer Slough
Bellefield North	0.11	Mercer Slough
8th Street	0.05 ³ / 0.13 ²	Mercer Slough
Lake Bellevue	0.54 ³ / 7.00 ²	Sturtevant Creek
South Lake	0.09	Sturtevant Creek
Central Lake	0.03	Sturtevant Creek
North Lake	0.04	Sturtevant Creek
BNSF Southwest	0.12	West Tributary
BNSF East	0.06 ³ / 0.12 ²	West Tributary
BNSF West	0.63 ³ / 0.83 ²	West Tributary
BNSF Northeast	0.02	West Tributary
BNSF Northwest	0.06	West Tributary
BNSF North	0.02	West Tributary
Kelsey West Tributary Pond	5.98 ²	West Tributary
Kelsey West Tributary Stream	0.04	West Tributary
136th Place	0.03	Kelsey Creek
SR 520 West	0.51 ³ / 0.64 ²	Valley Creek
Valley Creek	0.37	Valley Creek
SR 520 East	0.23	Valley Creek
Wetland D ⁴	>1.00	Coal Creek

Notes:

1 When only one number is present, total wetland area is located within the Project area. When two numbers are present, the wetland extends outside the Project area, and both the estimated total area (see footnote 2) and the delineated area (see footnote 3) are provided. Estimates for wetlands outside the Project area are based on observations during the field investigation and aerial photograph analysis. Wetland acreages were provided by HJH.

2 Approximate total wetland area, includes delineated area plus estimated wetland area extending outside Project area

3 Delineated wetland area within Project area

4 Wetland located at the Coal Creek mitigation site. Wetland delineation by Evans and Associates (2007).

sf = square feet

Table 2-5 Summary of Wetland USFWS Classification, Hydrogeomorphic Classification, State and Local Ratings, and Local Buffer Widths

Wetland Name	USFWS Classification	Hydrogeomorphic Classification Used for Rating	State (Ecology) and Local (Bellevue) Rating	Bellevue Buffer Widths (feet)
Mercer Slough	PFO, PSS, PEM, PAB	Depressional, Lake-Fringe, Riverine, Slope	II	110
Alcove Creek	PFO, PSS, PEM	Depressional, Riverine	II	75
Bellefield South	PFO, PSS, PEM	Riverine, Slope	II	75
Bellefield North	PFO, PSS	Riverine, Slope	II	75
8th Street	PFO, PSS, PEM	Depressional	III	60
Lake Bellevue	PAB	Depressional	III	60
South Lake	PFO, PSS, PEM	Depressional	III	60
Central Lake	PSS, PEM	Depressional	III	60
North Lake	PFO, PEM	Slope	IV	0
BNSF Southwest	PFO, PEM	Depressional, Slope	III	60
BNSF East	PEM	Depressional	III	60
BNSF West	PFO, PSS, PEM	Depressional, Slope	III	60
BNSF Northeast	PFO, PSS	Depressional	III	60
BNSF Northwest	PFO, PEM	Depressional, Slope	IV	40
BNSF North	PFO, PSS	Depressional, Slope	III	60
Kelsey West Tributary Pond	PFO, PEM	Depressional, Riverine	II	75
Kelsey West Tributary Stream	PFO, PSS, PEM	Riverine	III	60
136th Place	PFO, PSS, PEM	Depressional	III	60
SR 520 West	PFO, PSS, PEM	Depressional, Slope	III	60
Valley Creek	PFO, PSS, PEM	Riverine, Slope	II	75
SR 520 East	PFO, PSS, PEM	Slope	III	60
• Wetland D ¹	PFO, PEM	Riverine	II	110

Notes:

1. Wetland located at the Coal Creek mitigation site.

Ecology = U.S. Department of Ecology

PFO = palustrine forested

PSS = palustrine scrub-shrub

PEM = palustrine emergent

PAB = palustrine aquatic bed

USFWS = U.S. Fish and Wildlife Service

2.2.2.1. Mercer Slough Wetland

Mercer Slough Wetland is a large, heavily modified wetland system associated with Lake Washington. Prior to the Ballard Locks controlling the level of Lake Washington, Mercer Slough contained much more open water. The locks dropped the level of Lake Washington about 9 feet in 1916, exposing the saturated soils. Further dredging, ditching, and filling of the area through the first half of the 20th century for agricultural reasons further reduced the area of wetlands. By the last half of the 20th century, the slough experienced additional filling to accommodate I-405, and I-90 roadways. Approximately 130 acres of Mercer Slough was filled to create the Bellefield Office Park and the South Bellevue Park and ride in the 1960s and 1970s. The west channel around Bellefield Office Park is manmade and was created to float barges in for pile driving and construction of Bellefield Office Park. By the 1980s, continued urban development, including Newport Shores and the Newport Yacht Basin, added additional fill, peat removal, and draining. Today, Mercer Slough Park is approximately 350 acres. Portions of Mercer Slough Wetland were delineated within the Project area. Mercer Slough Wetland is also associated with several small streams (described in Section 2.3). For this investigation, only the western boundary of the wetland associated with the proposed Project alignment was delineated. The delineated boundary of the wetland is located adjacent to Bellevue Way SE and 112th Avenue SE. Based on aerial photograph analysis and City of Bellevue critical areas maps (City of Bellevue 2013b), the Mercer Slough Wetland is part of a very large wetland complex, approximately 350 acres or greater in size. The delineated boundary of the wetland is located adjacent to Bellevue Way SE and 112th Avenue SE (Appendix A, Frames 2, 3, and 4). The wetland is also identified on City critical areas maps (City of Bellevue 2013b).

Mercer Slough Wetland is a large wetland with PFO, PSS, PEM, and PAB vegetation classes and depressional, lake-fringe, riverine, and slope HGM classes. Dominant vegetation includes red alder, black cottonwood, western red cedar, Pacific willow (*Salix lasiandra*), red-osier dogwood (*Cornus sericea*), twinberry, spirea (*Spirea douglasii*), creeping buttercup, reed canarygrass, lady fern, and salmonberry. The wetland soils are saturated, seasonally inundated, and riverine and lake-fringe associated. Mercer Slough Wetland is a Category II wetland under Ecology's rating system and the City's critical areas regulations (110-foot buffer).

2.2.2.2. Alcove Creek Wetland

Alcove Creek Wetland is located in an area between residential development at SE 15th Street and 112th Avenue SE (Appendix A, Frame 5). The wetland extends outside the Project area to the west, and ROE was not provided to identify the entire wetland boundary. A 0.23-acre portion of the Alcove Creek Wetland was delineated within the Project area. Based on visual observations from within the Project area, aerial photograph analysis, and the location of development features that would limit the extent of the wetland system, the total size of the Alcove Creek Wetland is estimated to be approximately 0.64 acre if the two associated residential pond features meet the criteria of wetland habitat. The Alcove Creek Wetland is associated with Alcove Creek (Section 2.3). A portion of the wetland is identified on City critical areas maps (City of Bellevue 2013b).

Alcove Creek Wetland is a small wetland with PFO, PSS, and PEM vegetation classes and depressional and riverine HGM classes. Dominant vegetation includes red alder, Oregon ash, black cottonwood, Pacific willow, red-osier dogwood, lady fern, and skunk cabbage. It is a Category II wetland under Ecology's rating system and the City's critical areas regulations (75-foot buffer).

2.2.2.3. Bellefield South Wetland

Bellefield South Wetland is located between Mercer Slough Wetland and 112th Avenue, and north of SE 15th Street. This wetland is associated with Mercer Slough (Section 2.3). Bellefield North Wetland is located north of the wetland (Appendix A, Frame 5). The entire wetland boundary was delineated, approximately 0.29 acre within the Project area.

Bellefield South Wetland is a small wetland with PFO, PSS, and PEM vegetation classes and riverine and slope HGM classes. Dominant vegetation includes Oregon ash, red alder, Pacific willow, Himalayan blackberry, and stinging nettle. It is a Category II wetland under Ecology's rating system and the City's critical areas regulations (75-foot buffer).

2.2.2.4. Bellefield North Wetland

Bellefield North Wetland is located in an area between 112th Avenue SE and Mercer Slough Wetland and is associated with Mercer Slough (Section 2.3). Bellefield South Wetland is located approximately 50 feet south of Bellefield North Wetland (Appendix A, Frame 5). The entire wetland boundary, approximately 0.11 acre, was delineated within the Project area.

Bellefield North Wetland is a small wetland with PFO and PSS vegetation classes and riverine and slope HGM classes. Dominant vegetation includes Oregon ash, black cottonwood, red alder, Pacific willow, prickly currant, Himalayan blackberry, lady fern, and stinging nettle. Bellefield North Wetland is a Category II wetland under Ecology's rating system and the City's critical areas regulations (75-foot buffer).

2.2.2.5. 8th Street Wetland

The 8th Street Wetland is located in a narrow area between 112th Avenue NE and residential development (Appendix A, Frame 5). The 8th Street Wetland is approximately 0.13 acre. Due to lack of ROE, only the portion of the wetland located within the City ROW of 112th Avenue NE was delineated. The wetland area located on private property was evaluated using visual observations from the ROW on the east side of the wetland. A 0.05-acre portion of the 8th Street Wetland was delineated within the Project area. Based on visual observations from within the Project area, aerial photograph analysis, and the location of development features the wetland does not extend more than 30 feet west of the ROW.

The 8th Street Wetland is a small, narrow wetland with PFO, PSS, and PEM vegetation classes and has slope and depressional HGM class components. Dominant vegetation includes stinging nettle and reed canarygrass. The 8th Street Wetland is a Category III wetland under Ecology's rating system and the City's critical areas regulations (60-foot buffer).

2.2.2.6. Lake Bellevue Wetland

Lake Bellevue is regulated by the City of Bellevue as a wetland and not a lake because the system was historically a wetland that was dredged to create open water habitat. It is located east of the old BNSF railroad tracks south of NE 12th St. and north of NE 8th St. (Appendix A, Frame 9). Note that Sound Transit now owns a portion of the former BNSF ROW, but it is still referred to as BNSF ROW throughout the document. The wetland has commercial and residential structures built on piles that line the shoreline and are over much of the open water portion of the wetland. The western wetland boundary of the wetland, 0.54 acre, was delineated within the Project area. Based on visual observations from within the Project area, aerial photograph analysis, and the location of development features, the total size of the wetland is estimated to be 7 acres. A narrow upland area is located between the wetland and an adjacent wetland and the old BNSF railroad tracks.

Lake Bellevue Wetland is a large depressional feature with mostly PAB vegetation classes and a depressional HGM class. Tree, shrub, and emergent vegetation was located in the delineated portion of the wetland; however, this is only a small percentage of the overall wetland system, and therefore, the wetland is described as having a PAB vegetation class. Dominant vegetation within the delineated area was black cottonwood, red alder, spirea, reed canarygrass, English ivy, and horsetail. Lake Bellevue Wetland is a Category III wetland under Ecology's rating system and the City's critical areas regulations (60-foot buffer).

2.2.2.7. South Lake Wetland

South Lake Wetland is located in a narrow area between railroad tracks and development on the shoreline of Lake Bellevue (Appendix A, Frame 9). The entire wetland boundary, approximately 0.09 acre, was delineated within the Project area. Upland area is located between the wetland and Lake Bellevue.

South Lake Wetland is a small, narrow wetland with PFO, PSS, and PEM vegetation classes and a depressional HGM class. Dominant vegetation includes Hooker's willow, salmonberry, spirea, and reed canarygrass, with giant horsetail, Himalayan blackberry, and English ivy also occurring. South Lake Wetland is a Category III wetland under Ecology's rating system and the City's critical areas regulations (60-foot buffer).

2.2.2.8. Central Lake Wetland

Central Lake Wetland is located in a narrow area between railroad tracks and development on the shoreline of Lake Bellevue. The entire wetland boundary, approximately 0.03 acre, was delineated within the Project area (Appendix A, Frame 9). Upland area is located between the wetland and Lake Bellevue.

Central Lake Wetland is a small, narrow wetland with PSS and PEM vegetation classes and a depressional HGM class. Dominant vegetation includes spirea, reed canarygrass, water purslane, and Watson's willow herb, with red-osier dogwood and Himalayan blackberry also occurring. Central Lake

Wetland is a Category III wetland under Ecology's rating system and the City's critical areas regulations (60-foot buffer).

2.2.2.9. North Lake Wetland

North Lake Wetland is located in a narrow area between railroad tracks located to the east and development located to the west. The entire wetland boundary, approximately 0.04 acre, was delineated within the Project area (Appendix A, Frame 9).

North Lake Wetland is a small, narrow wetland with PFO and PEM vegetation classes and a slope HGM class. Dominant vegetation includes red alder, Scouler's willow, soft rush (*Juncus effusus*), and reed canarygrass, with Himalayan blackberry and Watson's willow-herb also occurring. North Lake Wetland is a Category IV wetland under Ecology's rating system and the City's critical areas regulations (no buffer due to wetland size of less than 2,500 sf).

2.2.2.10. BNSF Southwest Wetland

BNSF Southwest Wetland is located adjacent to railroad tracks located to the east and with commercial development located to the west. The entire wetland boundary, approximately 0.12 acre, was delineated within the Project area (Appendix A, Frame 10).

BNSF Southwest Wetland is a small, narrow wetland with PFO and PEM vegetation classes and depressional and slope HGM classes. Dominant vegetation includes black cottonwood, Pacific willow, red alder, reed canarygrass, and Colonial bentgrass. BNSF Southwest Wetland is a Category III wetland under Ecology's rating system and the City's critical areas regulations (60-foot buffer).

2.2.2.11. BNSF East Wetland

BNSF East Wetland is located between railroad tracks to the west and commercial development located to the east. This wetland has a long, linear ditch shape. A chain link fence runs along the east side of the wetland that provides the Project area boundary. A riprap embankment is located about 5 feet east of the fence. The wetland extends a few feet east of the fence. The wetland boundary within the Project area (0.06 acre, up to the fence) was delineated. Based on visual observations from within the Project area and the location of the embankment south of the chain link fence, the total size of the wetland is estimated to be 0.12 acre (Appendix A, Frame 10).

BNSF East Wetland is a small, narrow wetland with a PEM vegetation class and a depressional HGM class. Dominant vegetation includes cattail (*Typha latifolia*), common duckweed, reed canarygrass, and soft rush. BNSF East Wetland is a Category III wetland under Ecology's rating system and the City's critical areas regulations (60-foot buffer).

2.2.2.12. BNSF West Wetland

BNSF West Wetland is located adjacent to railroad tracks located to the east and has commercial development located to the west. A portion of BNSF West Wetland, approximately 0.63 acre, was delineated within the Project area. The wetland extends outside the Project area to the west

(Appendix A, Frame 10). Based on visual observations from within the Project area, aerial photograph analysis, and the location of development features that would limit the extent of the wetland system, the total wetland size is estimated to be 0.83 acre.

BNSF West Wetland has PFO, PSS, and PEM vegetation classes and depressional and slope HGM classes. Dominant vegetation includes Scouler's willow, red alder, spirea, lady fern, Colonial bentgrass, reed canarygrass, and piggyback plant. BNSF West Wetland is a Category III wetland under Ecology's rating system and the City's critical areas regulations (60-foot buffer).

2.2.2.13. BNSF Northeast Wetland

BNSF Northeast Wetland is located between railroad tracks, with commercial development located outside the railroad tracks. The entire wetland boundary, approximately 0.02 acre, was delineated within the Project area (Appendix A, Frame 10).

BNSF Northeast Wetland is a small, narrow wetland with PFO and PSS vegetation classes and a depressional HGM class. Dominant vegetation includes red alder, black cottonwood, spirea, and water purslane. BNSF Northeast Wetland is a Category III wetland under Ecology's rating system and the City's critical areas regulations (60-foot buffer).

2.2.2.14. BNSF Northwest Wetland

BNSF Northwest Wetland is located adjacent to railroad tracks located to the east with commercial development located to the west. The entire wetland boundary, approximately 0.06 acre, was delineated within the Project area (Appendix A, Frame 10).

BNSF Northwest Wetland is a small, narrow wetland with PFO and PEM vegetation classes and depressional and slope HGM classes. Dominant vegetation includes Pacific willow, lady fern, soft rush, and English ivy. BNSF Northwest Wetland is a Category IV wetland under Ecology's rating system and the City's critical areas regulations (40-foot buffer).

2.2.2.15. BNSF North Wetland

BNSF North Wetland is located between the fill prism of two railroad tracks located to the west with commercial development located to the east. The entire wetland boundary, approximately 0.02 acre, was delineated within the Project area (Appendix A, Frame 10).

BNSF North Wetland is a small, narrow wetland with PFO and PSS vegetation classes and depressional and slope HGM classes. Dominant vegetation includes black cottonwood, Pacific willow, spirea, and bittersweet nightshade. BNSF North Wetland is a Category III wetland under Ecology's rating system and the City's critical areas regulations (60-foot buffer).

2.2.2.16. Kelsey West Tributary Pond Wetland

Kelsey West Tributary Pond Wetland is located east of 124th Avenue NE and is entirely surrounded by commercial development (Appendix A, Frame 11). The pond itself is used for stormwater control, and its level is maintained by the City. An approximately 40-foot-wide weir is located at the southeast end

of the wetland to control flow out of the system. Approximately 5.98 acres of this wetland were delineated by Parametrix in 2011 as part of a City Project, and the data from that delineation were incorporated as part of the wetland delineation report (Parametrix 2012). The 2011 delineation was verified in 2013.

Kelsey West Tributary Pond Wetland is a large wetland with PFO and PEM vegetation classes and depressional and riverine HGM classes. This wetland is dominated by red alder, reed canarygrass, Pacific willow, spirea, and cattail. Kelsey West Tributary Pond Wetland is a Category II wetland under Ecology's rating system and the City's critical areas regulations (75-foot buffer).

2.2.2.17. Kelsey West Tributary Stream Wetland

Kelsey West Tributary Stream Wetland is associated with the West Tributary of Kelsey Creek, identified as West Tributary to Kelsey Creek Stream (Section 2.3). Kelsey West Tributary Stream Wetland is located in a narrow area between a paved parking lot and commercial developments. The entire wetland boundary, approximately 0.04 acre, was delineated within the Project area. The wetland is located on the left and right banks of the stream (Appendix A, Frame 11).

Kelsey West Tributary Stream Wetland is a small, narrow wetland with PFO, PSS, and PEM vegetation classes and a riverine HGM class. Dominant vegetation includes Pacific willow, red-osier dogwood, bittersweet nightshade, and reed canarygrass, with soft rush and Himalayan blackberry also occurring. Kelsey West Tributary Stream Wetland is a Category III wetland under Ecology's rating system and the City's critical areas regulations (60-foot buffer).

2.2.2.18. 136th Place Wetland

The 136th Place Wetland is located in a narrow area between commercial developments (Appendix A, Frame 13). A footbridge connects two commercial buildings on the east and west sides of the wetland. The footbridge crosses over the middle portion of the wetland and the Unnamed Tributary to Kelsey Creek. The entire wetland boundary, approximately 0.03 acre, was delineated within the Project area.

The 136th Place Wetland is a small, narrow wetland with PFO, PSS, and PEM vegetation classes and a depressional HGM class. Dominant vegetation includes red alder, Pacific willow, bittersweet nightshade, and reed canarygrass, with horsetail and English ivy also occurring. The 136th Place Wetland is a Category III wetland under Ecology's rating system and the City's critical areas regulations (60-foot buffer).

2.2.2.19. SR 520 West Wetland

SR 520 West Wetland is located in a narrow area between commercial development and the fill prism associated with SR 520, with 140th Avenue NE located to the east of the wetland (Appendix A, Frame 13). This wetland is located within the WSDOT ROW. Approximately 0.51 acre of SR 520 West Wetland was delineated within the Project area. The wetland extends outside the Project area to the west. Based on visual observations from within the Project area, aerial photograph analysis, and the

location of development features that would limit the extent of the wetland system, the total wetland size is estimated to be 0.64 acre.

SR 520 West Wetland is a small, narrow wetland with PFO, PSS, and PEM vegetation classes and depressional and slope HGM classes. Dominant vegetation includes red alder, black cottonwood, Pacific willow, red-osier dogwood, spirea, water parsley, and skunk cabbage, with horsetail and Himalayan blackberry also occurring. SR 520 West Wetland is a Category III wetland under Ecology's rating system and the City's critical areas regulations (60-foot buffer).

2.2.2.20. Valley Creek Wetland

Valley Creek Wetland is located between commercial development and SR 520, with 140th Avenue NE located to the west of the wetland. The wetland is located within WSDOT ROW (Appendix A, Frame 13). Only a portion of Valley Creek Wetland was investigated due to lack of ROE. For this investigation, a confirmation of the wetland boundary was completed based on information from a previous delineation as identified in the *East Link Light Rail Project Final EIS* (Sound Transit 2011), where the wetland is identified as Wetland WR-10W. The wetland was not flagged or surveyed as part of this investigation. The wetland appears to extend outside the Project area to the south for a short distance along Valley Creek between commercial development to the east and west; however, the available area between existing developments is only about 15 feet wide, including the stream channel. Based on visual observations from within the Project area, aerial photograph analysis, and the location of development features that would limit the extent of the wetland system, the approximate size of Valley Creek Wetland is 0.37 acre. Valley Creek Wetland is associated with Valley Creek.

Valley Creek Wetland is a small, narrow wetland with PFO, PSS, and PEM vegetation classes and riverine and slope HGM classes. Dominant vegetation includes red alder, black cottonwood, Pacific willow, bittersweet nightshade, spirea, and water parsley, with horsetail, reed canarygrass, red-osier dogwood, and Himalayan blackberry also occurring. Valley Creek Wetland is a Category II wetland under Ecology's rating system and the City's critical areas regulations (75-foot buffer).

2.2.2.21. SR 520 East Wetland

SR 520 East Wetland is located between commercial development and the fill prism associated with SR 520 (Appendix A, Frames 13 and 14). Only the west portion of this wetland was investigated due to lack of ROE. For this investigation, Anchor QEA performed a confirmation of the eastern portion of the wetland based on information from a previous delineation as identified in the *East Link Light Rail Project Final EIS* (Sound Transit 2011). The entire wetland boundary, including the delineated portion and the verified portion, is approximately 0.23 acre. The majority of the wetland is located within WSDOT ROW and the Project area.

SR 520 East Wetland is a small, narrow wetland with PFO, PSS, and PEM vegetation classes and a slope HGM class. Dominant vegetation includes red alder, black cottonwood, Scouler's willow, lady fern, and skunk cabbage, with horsetail and Himalayan blackberry also occurring. SR 520 East Wetland is a

Category III wetland under Ecology's rating system and the City's critical areas regulations (60-foot buffer).

2.2.2.22. Wetland D

Wetland D is located on the north side of Coal Creek between Coal Creek Parkway and Coal Creek. Wetland D is greater than 1 acre and includes an upper bench atop fill material and a lower bench on native soil adjacent to Coal Creek.

Wetland D has PFO and PEM vegetation classes and riverine HGM class. Dominant vegetation includes red alder, black cottonwood, Pacific willow, Scouler willow, salmonberry, reed canarygrass, lady fern, skunk cabbage, scouring rush, giant horsetail, and creeping buttercup, with Himalayan blackberry and English ivy also occurring, mostly on the upper bench. Wetland D is a Category II wetland under Ecology's rating system and the City's critical areas regulations (110-foot buffer).

2.2.3 Wetland Functional Analysis

Wetlands in the Project area provide many functions, including water quality improvements, floodwater storage, groundwater recharge, and wildlife habitat. However, wetlands in the Project area are typically located in low-lying areas adjacent to roads or other development features, and have been disturbed by human influence to some extent. Consequently, these wetlands are compromised in their ability to provide the full suite of these functions.

Based on the Ecology rating scores, the overall functions of each of the three wetland rating categories of water quality, hydrologic, and wildlife habitat are rated as low (less than 34 percent of the possible maximum score), moderate (34 percent to 67 percent of the possible maximum score), or high (greater than 68 percent of the possible maximum score). This method was used to identify the functions of wetlands within the Project area and is in accordance with Ecology methods for comparing functions between impacted wetlands and wetland mitigation sites (Ecology 2008b), which is discussed in Section 3.2.

Wetland function rating categories are summarized in Table 2-6. Water quality, hydrologic, and habitat functional value scores for wetlands in the Project area are shown in Table 2-7. The narrative that follows the tables provides a summary of the functions of only those wetlands within the Project area that will be disturbed, or have buffers that will be disturbed, under the proposed Project. A complete description of the functions the wetlands is presented in the Delineation Report (Anchor QEA 2014).

Table 2-6 Summary of Wetland Function Rating Categories

Qualitative Rating of Function	Improving Water Quality Potential (Point Range)	Improving Hydrologic Potential (Point Range)	Habitat Functions Potential (Point Range)	Habitat Functions Opportunity (Point Range)
High	11 to 16	11 to 16	13 to 18	13 to 18
Moderate	6 to 10	6 to 10	7 to 12	7 to 12
Low	0 to 5	0 to 5	0 to 6	0 to 6

Note:

Source: Ecology 2008b

Table 2-7 Summary of Functions and Values Wetland Rating Scores

Wetland	Water Quality Functions Potential Score	Water Quality Functions Opportunity (Yes/No)	Hydrologic Functions Potential Score	Hydrologic Functions Opportunity (Yes/No)	Habitat Functions Potential Score	Habitat Functions Opportunity Score	Total Functions Score ¹
Depressional and Riverine Maximum Scores	16	No = 1 Yes = 2	16	No = 1 Yes = 2	18	18	100
Mercer Slough	10	Yes	10	No	17	10	57
Alcove Creek	7	Yes	10	Yes	11	8	53
Bellefield South	10	Yes	8	Yes	10	8	54
Bellefield North	10	Yes	8	Yes	9	8	53
8th Street	3	Yes	12	Yes	6	5	41
Lake Bellevue	2	Yes	16	Yes	5	7	30
South Lake	7	Yes	8	Yes	8	5	43
Central Lake	5	Yes	10	Yes	7	4	41
BNSF Southwest	7	Yes	8	Yes	8	4	42
BNSF East	7	Yes	8	Yes	3	4	37
BNSF West	7	Yes	8	Yes	8	4	42
BNSF Northeast	7	Yes	8	Yes	6	4	40
BNSF Northwest	4	Yes	3	Yes	6	4	24
BNSF North	7	Yes	8	Yes	6	4	40
Kelsey West Tributary Pond	11	Yes	12	Yes	17 ²		63
Kelsey West Tributary Stream	8	Yes	9	Yes	9	7	50
136th Place	5	Yes	10	Yes	6	4	40
SR 520 West	9	Yes	8	Yes	9	5	48
Valley Creek	8	Yes	9	Yes	10	7	51
Wetland D	10	2	9	2	11	12	61
Slope Maximum Scores	12	No = 1 Yes = 2	8	No = 1 Yes = 2	18	18	76
North Lake	4	Yes	2	Yes	6	4	22
SR 520 East	5	Yes	5	Yes	9	4	33

Notes:

1 Total functions score calculated as: (Q x R) + (S x T) + U + V = W

Where:

Q = Water Quality Functions Potential Score

R = Water Quality Opportunity Score

S = Hydrologic Functions Potential Score

T = Hydrologic Functions Opportunity Score

U = Habitat Functions Potential Score

V = Habitat Functions Opportunity Score

W = Total functions score

2 Habitat Function potential/opportunity scores are combined due to unavailable data sheets (Parametrix 2012).

2.2.3.1. Water Quality Functions

All of the wetlands in the Project area provide opportunities to improve water quality to varying degrees, primarily because their location in an urban environment allows for the possibility of water quality improvement. Wetlands in the Project area with a moderate to high potential to improve water quality typically have a high proportion of wetland area with seasonal ponding or dense vegetation to restrict flow through the wetland.

2.2.3.2. Hydrologic Functions

With exception to Mercer Slough Wetland, all of the wetlands in the Project area provide opportunities to reduce flooding and erosion. Mercer Slough Wetland lacks the opportunity to reduce flooding or erosion because the wetland is associated with Lake Washington, which has its water level controlled by the Ballard Locks. Wetlands with moderate or high scores typically have characteristics such as a highly constricted outlets or significant water storage depths during wet periods. Wetlands with a low potential to reduce flooding and erosion is due to a lack of natural surface water outlets, ponding features, and the types of vegetation to reduce surface flows; a high presence of ditch-like characteristics; and small contribution of the wetland to the larger watershed.

2.2.3.3. Habitat Functions

Wetlands with a low score for habitat functions generally lack vegetative structure, simple or flashy hydroperiods, plant richness, habitat diversity, and special or unique habitat features. Wetlands with moderate or high scores typically have characteristics such as diverse habitat and vegetation classes, stable, or seasonal hydroperiods, high habitat interspersion, or the presence of special habitat features. Fourteen of the 22 wetlands have a low opportunity to provide habitat for many species. Wetlands with a low score for habitat opportunity are due to the characteristics of the wetland buffers and the overall lack of quality habitat conditions near or adjacent to the wetlands, including their proximity to roads. In addition to the wetlands being located near roads, the wetlands are often located near residential or commercial development. Wetlands with moderate scores have relatively undisturbed buffer areas.

2.2.3.4. Mercer Slough Wetland

Mercer Slough Wetland scores a moderate potential to improve water quality and provide opportunities to improve water quality (20 out of 32 possible maximum score). The wetland scores a moderate potential to reduce flooding and erosion and does not provide the opportunity to reduce flooding and erosion (10 out of 32 possible maximum score). The wetland scores a high potential and moderate opportunity (27 out of 36 possible maximum score) to provide habitat functions. Overall, the total Ecology wetland functions score for Mercer Slough Wetland is 57 out of a possible 100.

2.2.3.5. Alcove Creek Wetland

Alcove Creek Wetland scores a moderate potential to improve water quality and provide opportunities to improve water quality (14 out of 32 possible maximum score). The wetland scores a moderate potential to reduce flooding and erosion and provides the opportunity to reduce flooding and erosion

(20 out of 32 possible maximum score). The wetland scores a moderate potential and moderate opportunity (19 out of 36 possible maximum score) to provide habitat functions. Overall, the total Ecology wetland functions score for Alcove Creek Wetland is 53 out of a possible 100.

2.2.3.6. Bellefield South Wetland

Bellefield South Wetland scores a moderate potential to improve water quality and provide opportunities to improve water quality (20 out of 32 possible maximum score). The wetland scores a moderate potential to reduce flooding and erosion and provides the opportunity to reduce flooding and erosion (16 out of 32 possible maximum score). The wetland scores a moderate potential and moderate opportunity (18 out of 36 possible maximum score) to provide habitat functions. Overall, the total Ecology wetland functions score for Bellefield South Wetland is 54 out of a possible 100.

2.2.3.7. Bellefield North Wetland

Bellefield North Wetland scores a moderate potential to improve water quality and provide opportunities to improve water quality (20 out of 32 possible maximum score). The wetland scores a moderate potential to reduce flooding and erosion and provides the opportunity to reduce flooding and erosion (16 out of 32 possible maximum score). The wetland scores a moderate potential and moderate opportunity (17 out of 36 possible maximum score) to provide habitat functions. Overall, the total Ecology wetland functions score for Bellefield North Wetland is 53 out of a possible 100.

2.2.3.8. 8th Street Wetland

The 8th Street Wetland scores a low potential to improve water quality and provide opportunities to improve water quality (6 out of 32 possible maximum score). The wetland scores a high potential to reduce flooding and erosion and provides the opportunity to reduce flooding and erosion (24 out of 32 possible maximum score). The wetland scores a low potential and low opportunity (11 out of 36 possible maximum score) to provide habitat functions. Overall, the total Ecology wetland functions score for 8th Street Wetland is 41 out of a possible 100.

2.2.3.9. South Lake Wetland

South Lake Wetland scores a moderate potential to improve water quality and provide opportunities to improve water quality (14 out of 32 possible maximum score). The wetland scores a moderate potential to reduce flooding and erosion and provides the opportunity to reduce flooding and erosion (16 out of 32 possible maximum score). The wetland scores a moderate potential and low opportunity (13 out of 36 possible maximum score) to provide habitat functions. Overall, the total Ecology wetland functions score for South Lake Wetland is 43 out of a possible 100.

2.2.3.10. Central Lake Wetland

Central Lake Wetland scores a low potential to improve water quality and provide opportunities to improve water quality (10 out of 32 possible maximum score). The wetland scores a moderate potential to reduce flooding and erosion and provides the opportunity to reduce flooding and erosion (20 out of 32 possible maximum score). The wetland scores a moderate potential and low opportunity (11 out of

36 possible maximum score) to provide habitat functions. Overall, the total Ecology wetland functions score for Central Lake Wetland is 41 out of a possible 100.

2.2.3.11. North Lake Wetland

North Lake Wetland scores a low potential to improve water quality and provide opportunities to improve water quality (8 out of 24 possible maximum score). The wetland scores a low potential to reduce flooding and erosion and provides the opportunity to reduce flooding and erosion (4 out of 16 possible maximum score). The wetland scores a low potential and low opportunity (10 out of 36 possible maximum score) to provide habitat functions. Overall, the total Ecology wetland functions score for North Lake Wetland is 22 out of a possible 76.

2.2.3.12. BNSF East Wetland

BNSF East Wetland scores a moderate potential to improve water quality and provide opportunities to improve water quality (14 out of 32 possible maximum score). The wetland scores a moderate potential to reduce flooding and erosion and provides the opportunity to reduce flooding and erosion (16 out of 32 possible maximum score). The wetland scores a low potential and low opportunity to provide habitat functions (7 out of 36 possible maximum score). Overall, the total Ecology wetland functions score for BNSF East Wetland is 37 out of a possible 100.

2.2.3.13. BNSF Northeast Wetland

BNSF Northeast Wetland scores a moderate potential to improve water quality and provide opportunities to improve water quality (14 out of 32 possible maximum score). The wetland scores a moderate potential to reduce flooding and erosion and provides the opportunity to reduce flooding and erosion (16 out of 32 possible maximum score). The wetland scores a low potential and low opportunity to provide habitat functions (10 out of 36 possible maximum score). Overall, the total Ecology wetland functions score for BNSF Northeast Wetland is 40 out of a possible 100.

2.2.3.14. Kelsey West Tributary Pond Wetland

Kelsey West Tributary Pond Wetland was delineated and rated by Parametrix in 2011 as part of a City Project, and the data from that delineation was incorporated as part of the wetland delineation report. Kelsey West Tributary Pond Wetland scores a moderate potential to improve water quality and provide opportunities to improve water quality (22 out of 32 possible maximum score). The wetland scores a high potential to reduce flooding and erosion and provides the opportunity to reduce flooding and erosion (24 out of 32 possible maximum score). The wetland scores a moderate potential and opportunity (17 out of 36 possible maximum score) to provide habitat functions. Overall, the total Ecology wetland functions score for Kelsey West Tributary Pond Wetland is 63 out of a possible 100.

2.2.3.15. SR 520 West Wetland

SR 520 West Wetland scores a moderate potential to improve water quality and provide opportunities to improve water quality (18 out of 32 possible maximum score). SR 520 West Wetland scores a moderate potential to reduce flooding and erosion and provides the opportunity to reduce flooding and

erosion (16 out of 32 possible maximum score). The wetland scores a moderate potential and low opportunity (14 out of 36 possible maximum score) to provide habitat functions. Overall, the total Ecology wetland functions score for SR 520 West Wetland is 48 out of a possible 100.

2.2.3.16. Valley Creek Wetland

Valley Creek Wetland scores a moderate potential to improve water quality and provide opportunities to improve water quality (16 out of 32 possible maximum score). Valley Creek Wetland scores a moderate potential to reduce flooding and erosion and provides the opportunity to reduce flooding and erosion (18 out of 32 possible maximum score). The wetland scores a moderate potential and moderate opportunity (17 out of 36 possible maximum score) to provide habitat functions. Overall, the total Ecology wetland functions score for Valley Creek Wetland is 51 out of a possible 100.

2.2.3.17. SR 520 East Wetland

SR 520 East Wetland scores a low potential to improve water quality and provide opportunities to improve water quality (10 out of 24 possible maximum score). SR 520 East Wetland scores a low potential to reduce flooding and erosion and provides the opportunity to reduce flooding and erosion (10 out of 16 possible maximum score). The wetland scores a moderate potential and low opportunity (13 out of 36 possible maximum score) to provide habitat functions. Overall, the total Ecology wetland functions score for SR 520 East Wetland is 33 out of a possible 76.

2.2.3.18. Wetland D

Wetland D ratings are based on the 2004 Washington State rating system (Hruby 2004). Wetland D scores a moderate potential to improve water quality and provide opportunities to improve water quality (20 out of 32 possible maximum score). Wetland D scores a low potential to reduce flooding and erosion and provide the opportunity to reduce flooding and erosion (18 out of 32 possible maximum score). The wetland scores a high potential and opportunity (33 out of 36 possible maximum score) to provide habitat functions. Overall, the total Ecology wetland functions score for Wetland D is 61 out of a possible 76.

2.2.4 Wetland Impact Assessment

During the course of the Project, 12 of the 22 wetlands in the Project area will be permanently or temporarily disturbed. Approximately 0.43 acre of wetland will be permanently filled or graded to construct the Project, and 0.48 acre will be temporarily disturbed. Project activities will also require tree removal or replacement within wetland areas due to criteria outlined in Sound Transit's Design Criteria Manual (DCM; Sound Transit 2013) for light rail operations, which specifies that a "vegetation clear zone" (VCZ) be established. The tree removal or replacement results in a change in vegetation class and is defined as a wetland vegetation conversion impact. The Project is expected to have 0.76 acre of wetland vegetation conversion impacts. These conversion activities are described in Section 2.2.4.5.

The wetland buffers of 13 of the 22 wetlands in the Project area will be permanently filled or temporarily disturbed. Approximately 5.11 acres of wetland buffer will be permanently filled or graded to construct the Project, and 6.11 acres of wetland buffer will be temporarily disturbed.

Specific characteristics contributing to generally low to moderate values related to wetland functions include their association with roadside drainage ditches with culverts or catch basins that provide unconstricted or slightly constricted surface outlets; lack of ponding features and the types of vegetation to reduce surface flows; the overall lack of quality habitat conditions near or adjacent to the wetlands; and the general lack of vegetative structure, plant richness, habitat diversity, and special habitat features.

The temporary and permanent impacts to wetlands in the Project area will primarily result in a loss of stormwater management functions provided by these wetlands. Stormwater best management practices (BMPs) will be implemented as part of the Project; therefore, stormwater quality will be significantly improved as a whole, but wetland loss will reduce the flood water desynchronization, sediment removal, nutrient and toxicant removal, and erosion control functions provided by the affected wetlands.

2.2.4.1. Permanent Wetland Impacts

Permanent direct impacts from the proposed Project include filling and grading within the wetlands to construct the Project. Seven of the 22 wetlands in the Project area will be permanently disturbed because of partial filling or grading for Project construction for a total of 0.43 acre of permanent wetland impact. Four of the wetlands that will be permanently disturbed are Category II wetlands, and three are Category III wetlands according to the Ecology rating system. A summary of wetlands with permanent impacts under the Project is provided in Table 2-8. A summary of the classifications of wetlands with permanent impacts is provided in Table 2-9. Permanent wetland impact areas are shown in Appendix B.

Table 2-8 Summary of Permanent Wetland Impacts

Wetland Name	Size ¹ (acres)	State (Ecology) and Local (Bellevue) Rating	Permanent Impacts (acres)	Source of Impact
Mercer Slough	350 ²	II	0.17 ³	Geotechnical ground improvements (soil replacement, stone columns), access road between Winters House & Blueberry Farm, retaining wall at proposed Winters House parking lot, proposed storm drain easements/outfalls east and north of Winters House, and guideway location,
Bellefield South	0.29	II	0.05	Proposed realignment of SE 15 th St. and its associated retaining wall/footings
Bellefield North	0.11	II	0.01	Proposed realignment of SE 15 th St. and its associated retaining wall/footings
8th Street	0.05 ⁴ / 0.13 ²	III	0.13	Guideway location
BNSF East	0.06 ⁴ / 0.12 ²	III	0.05	Guideway location and associated ballast wall and relocated water line
Kelsey West Tributary Pond	5.98	II	0.01	Guideway column locations (drilled shafts)
SR 520 West	0.51 ⁴ / 0.64 ²	III	0.01	Location of guideway abutment and column (#D52—drilled shaft)
Total			0.43	

Notes:

1 When only one number is present, total wetland area is located within the Project area. When two numbers are present, the wetland extends outside the Project area, and both the estimated total area (see footnote 2) and the delineated area (see footnote 3) are provided. Estimates for wetlands outside the Project area are based on observations during the field investigation and aerial photograph analysis.

2 Approximate total wetland area, includes delineated area plus estimated wetland area extending outside project area.

3 This includes .02 acre of impact from pin piles, which is not regulated by the U.S. Army Corps of Engineers.

4 Delineated wetland area within project area

Table 2-9 Summary of Permanent Wetland Impacts by Classification

Classification Type	Class	Permanent Impact Area (acres)
Cowardin (USFWS)	PEM	0.05
	PFO, PEM	0.01
	PSS, PFO	0.01
	PFO, PSS, PEM	0.19
	PFO, PSS, PEM, PAB	0.17
Total		0.43
Ecology Rating	II	0.24
	III	0.19
Total		0.43
Hydrogeomorphic Class	Depressional	0.18
	Depressional, Lake-Fringe, Riverine, Slope	0.17
	Depressional, Riverine	0.01
	Depressional, Slope	0.01
	Riverine, Slope	0.06
Total		0.43

2.2.4.2. Temporary Wetland Impacts

Temporary impacts to seven wetlands will occur from vegetation clearing, alterations to existing grades, and shading from temporary structures. Project elements expected to cause temporary construction impacts to wetlands include construction access routes, grading, wall construction, temporary public traffic routes, staging areas, and utility installations and relocations.

Temporary wetland impacts would produce short-term loss of wetland functions during construction and for several years following construction. They would not, however, result in a permanent loss of wetlands after the Project is completed and once disturbed vegetation or wetland hydrology is reestablished. The extent of short-term degradation would vary depending on the intensity of the temporary impacts but is anticipated to be from 1 to 3 years. Wetlands where the vegetation is cleared or trimmed would still retain some water quality and quantity function, although at a diminished level. Temporarily filled wetlands would provide no beneficial functions until they are restored. Wetlands temporarily impacted during construction would be restored to pre-existing grades and replanted following the completion of work, and it is anticipated that they would return to a functioning state within 5 years. Seven of the 22 wetlands in the Project area would result in approximately 0.48 acre of short-term loss of wetland functions. This estimate is based on offsets from planned cut and fill and further avoidance and minimization activities during construction may reduce this impact. A summary

of wetlands with temporary impacts under the Project is provided in Table 2-10. Temporary wetland impact areas are shown in Appendix B.

Table 2-10 Summary of Temporary Wetland Impacts

Wetland Name	Size ¹ (acres)	State (Ecology) and Local (Bellevue) Rating	Temporary Impacts (acres)	Source of Impact
Impacts Related to Light Rail Construction				
Mercer Slough	350 ²	II	0.22	Future installation of proposed boardwalk, construction of retaining wall at Winters House (scaffolding, vehicles), construction access (vehicular) between Winter's House and Wye Creek (along east side of proposed guideway)
Alcove Creek	0.23 ³ / 0.64 ²	II	0.01	Construction of retaining wall along west side of 112th Avenue SE (scaffolding, vehicles)
Bellefield South	0.29	II	0.04	Construction of retaining wall at SE 15th Street (scaffolding, vehicles), geotechnical ground improvements (soil replacement)
Bellefield North	0.11	II	0.02	Construction of retaining wall at SE 15 th St. (scaffolding, vehicles), geotechnical ground improvements (soil replacement)
North Lake	0.04	IV	0.04	Location of guideway trestle structure and construction access vehicles
Kelsey West Tributary Pond	5.98 ²	II	0.05	Location of guideway drilled shaft column and temporary access road.
Subtotal Impacts Related to Light Rail Construction			• 0.38	
Impacts Related to Mitigation				
Wetland D	> 1	II	0.10 ⁴	Installation of ELJ and LWD clusters for habitat improvement/ mitigation
Subtotal Impacts Related to Mitigation			0.10	
Total Wetland Impacts			0.48	

Notes:

1 When only one number is present, total wetland area is located within Project area. When two numbers are present, the wetland extends outside the Project area and both the estimated total area (see footnote 2) and the delineated area (see footnote 3) are provided. Estimates for wetlands outside the Project area are based on observations during the field investigation and aerial photograph analysis. Wetland acreages were provided by HJH.

2 Approximate total wetland area, includes delineated area plus estimated wetland area extending outside project area.

3 Delineated wetland area within project area.

4 Impacts to Wetland D will be less than 12 months in duration and therefore additional compensatory mitigation is not required.

2.2.4.3. Permanent Wetland Buffer Impacts

Permanent wetland buffer impacts would result in a decrease in area adjacent to wetland areas, which could consequently result in decreased wetland function for the remaining wetlands within the Project area after construction. Twelve of the 22 wetlands in the Project area would have permanent wetland buffer impacts because of partial filling or grading for Project construction for a total of 5.11 acres of permanent wetland buffer impact. A summary of wetlands with permanent buffer impacts under the Project is provided in Table 2-11. Permanent wetland buffer impact areas are shown in Appendix B.

Many of the buffers are currently managed lawns, or dominated by invasive species such as Himalayan blackberry (e.g., much of the area between the Mercer Slough wetland and 112 Avenue NE. Impacts to these buffers will be partially or fully mitigated through the enhancement of the remaining buffer. At the South Bellevue Station a new parking structure will be developed within the footprint of the existing parking lot. This will be an intensification of use in an already developed area of the buffer. South Bellevue station was originally constructed in 1980. Due to the reconstruction of the site, the storm water systems will be expanded to accommodate the new stormwater requirements. The expansion will occur towards existing parking lot, within wetland buffer; this was previously deemed acceptable to impact by COB but will be an intensification of development within the buffer. The mitigation for the intensification of developed wetland buffers will be achieved through the restoration and enhancement of the remaining buffer (see Section 3.0).

Table 2-11 Summary of Permanent Wetland Buffer Impacts

Wetland Name	State (Ecology) and Local (Bellevue) Rating	Permanent Buffer Impacts ² (acres)	Source of Impact
Mercer Slough	II	4.10 ¹	Guideway location, guideway column locations (drilled shafts), perimeter ornamental landscape south of the South Bellevue Station parking structure, access road between Winters House and Blueberry Farm, sidewalk improvements along Bellevue Way SE, improvements to the Winters House parking lot, location of proposed building pad for future retail building, (21) proposed storm drain easements/outfalls, SE 15th Street realignment
Alcove Creek	II	0.09	Location of retaining wall along west side of 112 th Ave. SE, sidewalk improvements, location of realigned Bellefield Park Lane
Bellefield South	II	0.20	Location of realigned SE 15 th St. and adjacent sidewalk
Bellefield North	II	0.24	Location of realigned SE 15 th St. and adjacent sidewalk
South Lake	III	0.01	Location of guideway columns (drilled shafts)
Central Lake	III	0.05	Location of guideway columns (drilled shafts) location of guideway trestle
BNSF West	III	0.09	Location of relocated 12-inch water line
BNSF East	III	0.14	Location of guideway and associated ballast wall
BNSF Northeast	III	0.04	Location of guideway and associated ballast wall
Kelsey West Tributary Pond	II	0.13	Location of storm drain easements/outfalls, location of guideway columns (drilled shafts)
SR 520 West	III	0.01	Location of guideway columns (drilled shafts)
Valley Creek	II	0.01	Location of guideway columns (drilled shafts)
Total		5.11	

Notes:

1 Does not include the 0.66 acre of Mercer Slough buffer impact that is due to the intensification of use when the existing parking lot within the buffer is converted to a parking structure for the South Bellevue Station.

2.2.4.4. Temporary Wetland Buffer Impacts

Project elements expected to cause temporary construction impacts to wetland buffers include construction access routes, temporary public traffic detour routes, staging areas, and utility installations and relocations. Ten of the 22 wetlands in the Project area will have temporary wetland buffer impacts for a total of 6.11 acres. This estimate is based on offsets from planned cut and fill, VCZ, and further avoidance and minimization during construction may reduce this impact. A summary of wetlands with temporary buffer impacts under the Project is provided in Table 2-12. Temporary wetland buffer impact areas are shown in Appendix B.

In addition to the impacts listed below, constructing stream enhancements at the Coal Creek site will result in temporary disturbance to wetland buffers. Disturbances include removing vegetation, stockpiling materials, storing equipment, and soil disturbance to provide construction access.

Table 2-12 Summary of Temporary Wetland Buffer Impacts

Wetland Name	State (Ecology) and Local (Bellevue) Rating	Temporary Impacts ¹ (acres)	Source of Impact
Mercer Slough	II	4.43	Construction access (vehicular) and staging, geotechnical ground improvements (soil replacement, stone columns), grading activities associated with guideway and retaining wall locations
Alcove Creek	II	0.08	Construction access for retaining wall (scaffolding, vehicles)
Bellefield South	II	0.01	Construction access for retaining wall (scaffolding, vehicles)
Bellefield North	II	0.04	Construction access for retaining wall (scaffolding, vehicles)
South Lake	III	0.27	Construction access for guideway and columns (scaffolding, vehicles)
Central Lake	III	0.09	Construction access for guideway and trestle (scaffolding, vehicles)
BNSF East	III	0.01	Construction access for guideway and ballast wall (vehicles)
Kelsey West Tributary Pond	II	0.36	Construction access for guideway and columns (scaffolding, vehicles)
SR 520 West	III	0.55	Construction access for guideway and columns (scaffolding, vehicles)
Valley Creek	II	0.27	Construction access for guideway and columns (scaffolding, vehicles)
Total		6.11	

Note:

1 Temporary disturbance to wetland or riparian buffers are not included from Coal Creek stream enhancement actions.

2.2.4.5. Wetland Vegetation Conversion Impacts

Project activities will require tree removal or replacement within wetland areas from criteria outlined in Sound Transit's DCM for light rail operations (Sound Transit 2013), which specifies that a "vegetation clear zone" be established. The tree removal or replacement results in a change in vegetation class and is defined as a wetland vegetation conversion impact. Light rail safety guidelines dictate that trees not be located beneath the light rail guideway or that tree trunks not be located within 17 feet from the edge of the guideway or 31 feet from the center of the guideway to provide safe operating conditions. Therefore, all trees located within these areas of the Project will be removed or replaced with tree or shrub species that are anticipated to not interfere with operations in both upland and wetland areas,

but only wetland areas are considered a vegetation conversion wetland impact. Tree removal and/or pruning in these areas will be an ongoing maintenance activity associated with operation of the light rail.

Removing trees and implementing ongoing maintenance activities to prevent trees from encroaching into the areas under and adjacent to the light rail guideway will result in a decrease in wetland functions in these areas. In general, existing PFO wetland habitat will be converted to PSS and or PEM habitat. Losing tree cover within a wetland system can decrease specific wetland functions such as plant species diversity, evapotranspiration rates, and habitat wildlife features. If tree removal resulted in the loss of all tree vegetation cover within a wetland, losing PFO habitat would result in a decrease in Ecology's wetland rating score for the given wetland. If tree removal resulted in the loss of a portion of trees within the wetland, the Ecology wetland rating score could remain unchanged. Mitigation for tree removal in wetland areas will include re-planting wetland shrub and herbaceous vegetation and enhancing wetlands at a mitigation area adjacent to the Project alignment. Dense shrub growth in these areas will reduce the functional loss of removing trees and will also reduce the establishment of colonizing tree species.

In order to mitigate impacts to existing Mercer Slough Park trails, a new boardwalk is proposed within Mercer Slough Nature Park. The boardwalk will be permitted under this Project; however, the final design and construction will be handled by the City of Bellevue. Most of this boardwalk will be installed within wetland areas and will result in a permanent wetland vegetation conversion impact due to the anticipated conversion from a PSS to a PEM. The pin piles needed for structural support will have a permanent impact to the wetland and will total approximately 0.02 acre.

Six of the 22 wetlands in the Project area will have vegetation conversion impacts for a total of 0.76 acre. While these are considered to be permanent impacts, the mitigation approach does not have the same ratio requirements, which is why it is listed separately from other permanent wetland impacts. A schematic representation of tree removal and associated mitigation in wetland areas is shown in Figure 2-2. A summary of wetlands with vegetation conversion impacts under the Project is provided in Table 2-13.

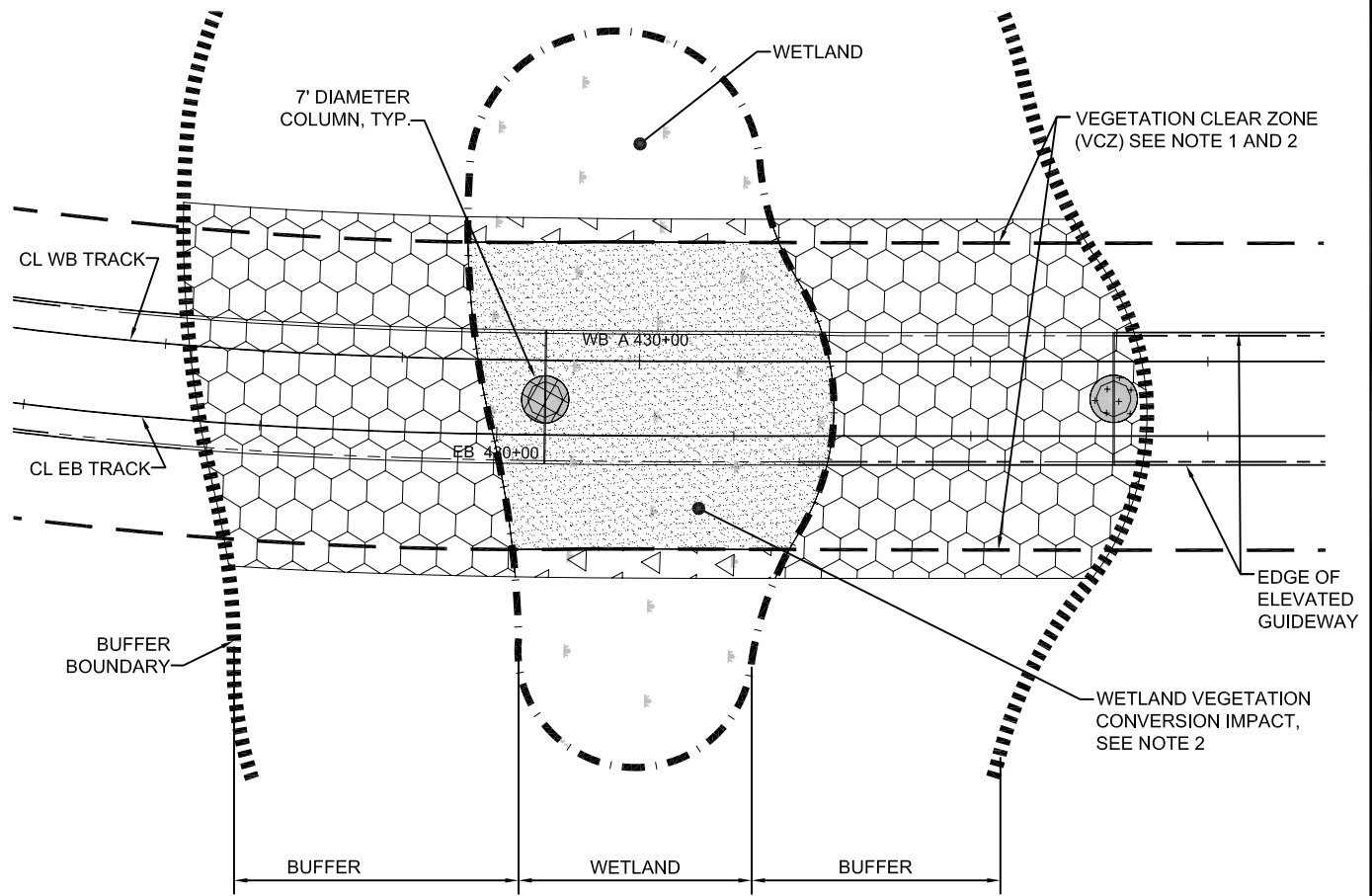

IMPACTS

RESTORATION / MITIGATION

PERMANENT WETLAND IMPACT		WETLAND CREATION AND ENHANCEMENT AT MITIGATION SITES
PERMANENT WETLAND VEGETATION CONVERSION IMPACT		RESTORATION ON SITE WITH EMERGENT AND LOW PLANTING, PLUS ENHANCEMENT AT MITIGATION SITES
TEMPORARY WETLAND IMPACT		RESTORATION ON SITE (WITH THE EXCEPTION OF NO TREES IN THE VCZ)
PERMANENT BUFFER IMPACT		BUFFER CREATION AND ENHANCEMENT AT MITIGATION SITES
TEMPORARY BUFFER IMPACT		RESTORATION ON SITE

NOTES:

1. AT ELEVATED GUIDEWAY AND TRANSITION STRUCTURES, TREES WITH A 30 FOOT DIAMETER OR LESS AT MATURITY THAT ARE NOT ANTICIPATED TO EXCEED THE HEIGHT OF THE RAILING SHALL BE PLANTED NO CLOSER THAN 31 FEET FROM CENTER OF GUIDEWAY TO CENTER OF TREE OR 17 FEET FROM EDGE OF GUIDEWAY TO CENTER OF TREE. FOR TREES ANTICIPATED TO BE TALLER THAN THE RAILING HEIGHT, THE TREE BRANCHING SHALL BE NO CLOSER THAN 11 FEET TO THE EDGE OF THE GUIDEWAY.
2. WETLAND AREAS WITHIN THE VCZ ARE CONSIDERED TO BE PERMANENT WETLAND VEGETATION CONVERSION IMPACT AREAS IF THERE IS A CHANGE IN VEGETATION CLASS (FOR EXAMPLE, A CONVERSION FROM FORESTED WETLAND TO SCRUB-SHRUB WETLAND). MITIGATION FOR IMPACTS TO THESE AREAS SHALL INCLUDE REPLANTING IN THE RIGHT-OF-WAY AND WETLAND ENHANCEMENT AT MITIGATION SITES.



Table 2-13 Summary of Wetland Vegetation Conversion Impacts

Wetland Name	State (Ecology) and Local (Bellevue) Rating	Vegetation Conversion Impacts (acres)	Source of Impact
Mercer Slough	II	0.32	Conversion of vegetation types under guideway and within Vegetation Conversion Zones (approx. 20-24' from edge of guideway), vegetation conversion under future boardwalk
South Lake	III	0.09	Conversion of vegetation types under guideway and within Vegetation Conversion Zones (approx. 20-24' from edge of guideway)
Central Lake	III	0.03	Conversion of vegetation types under guideway and within Vegetation Conversion Zones (approx. 20-24' from edge of guideway)
BNSF East	III	0.08	Conversion of vegetation types under within Vegetation Conversion Zones (approx. 20-24' from edge of guideway)
SR 520 West	III	0.23	Conversion of vegetation types under guideway and within Vegetation Conversion Zones (approx. 20-24' from edge of guideway)
Valley Creek	II	0.01	Conversion of vegetation types under guideway and within Vegetation Conversion Zones (approx. 20-24' from edge of guideway)
Total		0.76	

2.2.5 Wetland Regulatory Compliance

Guidance from USFWS, Ecology, and the City was used to determine the wetland classifications and appropriate buffer widths. Information and excerpts from the specific guidance language are provided in section 2.2.5.1. Table 2-5 lists the USFWS classifications for the wetlands and the Ecology and City wetland ratings and classifications. Ecology wetland rating forms for the 22 delineated wetlands are found in Appendix A.

2.2.5.1. Wetland Buffer Requirements

Appropriate minimum wetland buffers were identified according to the current BCC (City of Bellevue 2013a). The BCC identifies minimum protective buffer widths based on the wetland category, per the Ecology rating system, the existing land use within the prescribed buffer, and the Ecology function scores for habitat. According to the BCC, wetland buffers shall be established from the wetland edge, as summarized in Table 2-14. Bellevue will determine the final wetland ratings and minimum buffers. Wetland buffer widths based on the local rating are identified in Table 2-15.

Table 2-14 City of Bellevue Wetland and Wetland Buffer Regulations

Wetland Category	Wetland Characteristics ¹	Buffer Width (feet)
Category I	Natural heritage wetlands	190
	Bogs	190
	Forested	Based on score for habitat or water quality functions
	Habitat score of 29 to 36	225
	Habitat score of 20 to 28	110
	Water quality score of 24 to 32 and habitat score of less than 20	75
	Not meeting any of the above	75
Category II	Habitat score of 29 to 36	225
	Habitat score of 20 to 28	110
Category III	Water quality score of 24 to 32 and habitat score of less than 20	75
	Not meeting any of the above	75
Category III	Habitat score of 20 to 28 points	110
	Not meeting any of the above	60
Category IV (more than 2,500 square feet)	Score for functions less than 30 points	40

Notes:

Source: City of Bellevue 2013a, Chapter 20.25H.095.C.1.a

1 Habitat and water quality scores per Hruby 2004 and Ecology 2008a.

Table 2-15 City of Bellevue Regulations Wetland Rating and Buffer Distance

Wetland	State and Local Wetland Rating ¹	Wetland Characteristics Buffer Criteria	Buffer Width (feet)
Mercer Slough	II	Habitat Score 20 to 28	110
Alcove Creek	II	Habitat Score < 20	75
Bellefield South	II	Habitat Score < 20	75
Bellefield North	II	Habitat Score < 20	75
8th Street	III	Habitat Score < 20	60
Lake Bellevue	III	Habitat Score < 20	60
South Lake	III	Habitat Score < 20	60
Central Lake	III	Habitat Score < 20	60
North Lake	IV	< 2,500 sf	0
BNSF Southwest	III	Habitat Score < 20	60
BNSF East	III	Habitat Score < 20	60
BNSF West	III	Habitat Score < 20	60

Wetland	State and Local Wetland Rating ¹	Wetland Characteristics Buffer Criteria	Buffer Width (feet)
BNSF Northeast	III	Habitat Score < 20	60
BNSF Northwest	IV	> 2,500 sf	40
BNSF North	III	Habitat Score < 20	60
Kelsey West Tributary Pond	II	Habitat Score < 20	75
Kelsey West Tributary Stream	III	Habitat Score < 20	60
136th Place	III	Habitat Score < 20	60
SR 520 West	III	Habitat Score < 20	60
Valley Creek	II	Habitat Score < 20	75
SR 520 East	III	Habitat Score < 20	60
Wetland D	II	Habitat Score 20 to 28	110

Notes:

1 All wetlands identified during the investigation were located within the City jurisdiction.
sf = square feet

2.3 Streams

Streams in the Project area were identified, and the stream ordinary high water marks (OHWMs) were delineated based on the criteria identified in the BCC LUC 20.25H.095 (City of Bellevue 2013a). Stream locations are shown on Figure 2-1. The results of the stream OHWM survey are presented in the Delineation Report (Anchor QEA 2014). The stream OHWM survey methods and results from that report are summarized in the following sections.

2.3.1 Methods

To document the OHWM of the streams within the Project area, existing information was reviewed (described in Section 1.3.1), an aerial photograph analysis was performed, and site visits were conducted in February, March, April, and May 2013. The OHWM delineation was completed by walking the stream shorelines and identifying the OHWM with flagging for survey or collected OHWM data with a global positioning system (GPS) unit. Delineated stream reaches within the Project area were limited in some areas due to lack of ROE.

The stream OHWM boundaries were identified consistent with Chapter 90.58 of the Revised Code of Washington (RCW) and Chapter 173-22 of the WAC. The WAC provides the following definition:

“Ordinary high water line” means the mark on the shores of all waters that will be found by examining the bed and banks and ascertaining where the presence and action of waters are so common and usual and so long continued in ordinary years, as to mark upon the soil or vegetation a character distinct from that of the abutting upland: Provided, that in any area where the ordinary high water line cannot be found the ordinary high water line adjoining saltwater shall be the line of mean higher high water

and the ordinary high water line adjoining freshwater shall be the elevation of the mean annual flood.

Guidance and policy documents from WDFW and Ecology use OHWM and “ordinary high water line” interchangeably; this report uses OHWM.

2.3.1.1. Stream Classifications

A stream is defined by the City (BCC LUC 20.25H.075) as an aquatic area where surface water produces a channel, not including a wholly artificial channel, unless the artificial channel is:

1. Used by salmonids; or
2. Used to convey a stream that occurred naturally before construction of the artificial channel.

Streams are classified under the BCC LUC 20.25H.075.A into four categories (Types S, F, N, and O) that are defined as follows:

- Type S water means all waters, other than shoreline critical areas designated under LUC 20.25E.017, within their bankfull width, as inventoried as “shorelines of the state” under Chapter 90.58 RCW and the rules promulgated pursuant to Chapter 90.58 RCW, including periodically inundated areas of their associated wetlands.
- Type F water means all segments of waters that are not Type S waters, and that contain fish or fish habitat, including waters diverted for use by a federal, state, or tribal fish hatchery from the point of diversion, for 1,500 feet or the entire tributary, if the tributary is highly significant for protection of downstream water quality.
- Type N water means all segments of waters that are not Type S or F waters and that are physically connected to Type S or F waters by an aboveground channel system, stream, or wetland.
- Type O water means all segments of waters that are not Type S, F, or N waters and that are not physically connected to Type S, F, or N waters by an aboveground channel system, stream, or wetland.

2.3.2 Stream Study Results

Eleven streams were identified within the Project area. The Project area spans a cumulative length of 7.13 miles (Figure 1-1) and contains nine drainage basins within the Cedar/Sammamish Watershed (WRIA 8) (Ecology 2015). The eight basins within the City are shown on Figure 1-4. Streams are described in location sequence from west to east. Each stream was given a descriptive name to reflect its relative location along the alignment. This section provides a summary of the 11 streams within the Project area. A complete description of the 10 streams adjacent to the guideway, including the OHWM results, is presented in the Delineation Report (Anchor QEA 2014). Additional information about Coal Creek is found in the *Coal Creek Stream Enhancement Project Hydraulic Effects Memorandum* (Appendix H). Table 2-16 presents a summary of the streams in the Project area, approximate stream

OHWL length, and the stream's drainage basin. Stream local ratings and buffer widths per the BCC are identified in Table 2-17 and were measured from the top of bank as shown on topographic survey conducted for the project.

Table 2-16 Summary of Streams Located within the Project Area

Stream	OHWL Length ¹ (feet)	Drainage Basin ²
Stream A	260	Mercer Slough
Stream B	83	Mercer Slough
Wye Creek	150	Mercer Slough
Alcove Creek	226	Mercer Slough
Sturtevant Creek	689	Sturtevant Creek
West Tributary to Kelsey Creek	321	West Tributary
Stream C	291	West Tributary
Goff Creek	61	Goff Creek
Unnamed Tributary to Kelsey Creek	342	Kelsey Creek
Valley Creek	205	Valley Creek
Coal Creek	750	Coal Creek

Notes:

Stream delineations were limited within some areas of the Project area due to lack of Rights-of-Entry.

1 Calculations provided by HJH for open channel areas that were delineated.

2 City of Bellevue 2013b

OHWL = ordinary high water mark

Table 2-17 Local Critical Areas Regulations Stream Rating and Buffer Distance

Stream	Local Stream Rating ¹	Buffer Width (feet) ²
Stream A	Type N	50
Stream B	Type N	50
Wye Creek	Type F	100
Alcove Creek	Type F	100
Sturtevant Creek	Type F	50 ³
West Tributary to Kelsey Creek	Type F	50 ⁴
Stream C	Type O	25
Goff Creek	Type F	50 ²
Unnamed Tributary to Kelsey Creek	Type N	50
Valley Creek	Type F	50 ²
Coal Creek	Type F	100

Notes:

- 1 BCC (City of Bellevue 2013a).
- 2 Buffer is measured from Top of Bank
- 3 These streams' buffers were applied based on guidance from City of Bellevue 2013a, Chapter 20.25H.075.C.1.a.
- 4 Open stream segments, regardless of type, of the West Tributary of Kelsey Creek on developed and undeveloped sites shall have a stream critical area buffer of 50 feet, measured from the top-of-bank. (City of Bellevue 2013a, Chapter 20.25H.075.C.1.c.)

2.3.2.1. Stream A

Stream A is an unnamed stream that flows from wetland seeps near 112th Avenue SE and the western edge of the Mercer Slough Wetland (Section 2.2.2.1). The stream flows outside the Project area to the east. Based on observations during the field investigation and an analysis of aerial photographs, Stream A appears to drain into the Mercer Slough. An approximately 260-foot reach of Stream A was delineated within the Project area (Appendix A, Frame 4). Stream A appears to meet the criteria of a Type N water under the City's critical areas regulations (50-foot buffer), physically connected to Type S or F waters (Mercer Slough) by an aboveground channel system, stream, or wetland. Stream A is not identified on City critical area maps (City of Bellevue 2013b) or WDFW PHS maps (WDFW 2013a).

2.3.2.2. Stream B

Stream B is an unnamed stream that flows east from wetland seeps near 112th Avenue SE and the western edge of the Mercer Slough Wetland (Section 2.2.2.1). Stream B flows into Stream A within the Project area (Appendix A, Frame 4). An approximately 83-foot reach of Stream B was delineated within the Project area. Stream B appears to meet the criteria of a Type N water under the City's critical areas regulations (25- or 50-foot buffer, depending on site conditions), physically connected to Type S or F waters (Mercer Slough) by an aboveground channel system, stream, or wetland. Site conditions indicate the stream warrants a 50-foot buffer. Stream B is not identified on City critical area maps (City of Bellevue 2013b) or WDFW PHS maps (WDFW 2013a).

2.3.2.3. Wye Creek

Wye Creek is an unnamed stream that flows east from a pair of culverts located under the split at Bellevue Way and 112th Avenue SE. The stream was originally characterized as a wetland, but it was delineated as a stream during field investigations. Wye Creek flows east into the Mercer Slough Wetland Complex. An approximately 150-foot reach of Wye Creek flows within the Project area (Appendix A, Frame 4). Wye Creek appears to meet the criteria of a Type F rating under the City's critical areas regulations (100-foot buffer), physically connected to Type S waters (Mercer Slough) by an aboveground channel system, stream, or wetland. Wye Creek is not identified on City critical area maps (City of Bellevue 2013b) or WDFW PHS maps (WDFW 2013a).

2.3.2.4. Alcove Creek

Alcove Creek is a stream that originates from two manmade ponds within the Alcove Creek Wetland (Section 2.2.2.2), located within a residential development. The creek flows east through a culvert under 112th Avenue SE (Appendix A, Frame 5). There is no open channel of Alcove Creek east of 112th Avenue SE; however, the stream flows directly into the Mercer Slough from a hanging culvert. A second pond is located upstream of the first pond that is located outside the Project area. The upstream location of the stream is located outside the Project area boundary and was not identified during the investigation. The Project drainage team identified an artificial hydrology source, which pumps water from the Mercer Slough to the upper pond. Alcove Creek flows in an open channel for about 240 lineal feet within the Project area. Alcove Creek meets the criteria of Type F waters under the City's critical areas regulations (100-foot buffer), physically connected to Type S waters (Mercer Slough) by an aboveground channel system, stream, or wetland. Alcove Creek is not identified on City critical areas maps (City of Bellevue 2013b) or WDFW PHS maps (WDFW 2013a).

2.3.2.5. Sturtevant Creek

Within the Project area, Sturtevant Creek flows from Lake Bellevue south along the former BNSF railway for approximately 600 feet before flowing through another approximately 35-foot-long culvert located beneath railroad tracks (Appendix A, Frame 9; Appendix B, Figures 12 and 16 through 21). The stream then flows west for approximately 20 feet before flowing into a culvert of unknown length to the west near I-405. Sturtevant Creek passes under I-405 through an approximately 250-foot culvert located 700 feet south of Main Street. An approximately 689-foot reach of Sturtevant Creek was delineated within the Project area. Sturtevant Creek is identified as a Type F water on City critical area maps (City of Bellevue 2013b). Under the City's critical areas regulations, Type F waters have a 50- or 100-foot protective buffer, depending on site conditions. Site conditions indicate that this stream warrants a 50-foot buffer. This reach of Sturtevant Creek is not identified on WDFW PHS maps (WDFW 2013a).

2.3.2.6. West Tributary to Kelsey Creek

Within the Project area, the West Tributary to Kelsey Creek flows from the Kelsey West Tributary Pond Wetland southeast and then south from an approximately 60-foot long culvert located beneath a large reinforced weir (Appendix A, Frame 11). An approximately 321-foot reach of the stream was delineated

within the Project area. The stream flows into a culvert at the downstream end of the OHWM delineation. The West Tributary to Kelsey Creek appears to meet the criteria of Type F waters under the City of Bellevue's critical areas regulations. The Bellevue LUC dictates a stream critical area buffer of 50-foot buffer from the top of bank for all open stream segments, regardless of type, on the West Tributary of Kelsey Creek (City of Bellevue 2013a, Chapter 20.25H.075.C.1.c.). Site conditions indicate that the stream warrants a 50-foot buffer. This reach is not identified on WDFW PHS maps (WDFW 2013a).

2.3.2.7. Stream C

Stream C is an unnamed stream that flows west and into a culvert at the upstream and downstream reaches (Appendix A, Frames 11 and 12). Based on aerial photograph analysis, this system appears to be an unnamed tributary to the West Tributary to Kelsey Creek. The culverts are located beneath commercial development near the Project area. An approximately 291-foot reach of Stream C was delineated within the Project area. Stream C discharges into West Tributary to Kelsey Creek via a culvert. The upstream source of the stream could not be identified based on observations during the site visits and a review of City of Bellevue stream and culvert information. Surface runoff from surrounding development appears to contribute to the system; however, during two site visits that occurred when no precipitation was present for at least 2 days prior to the site visits, flow was present in the stream, indicating that surface runoff could not be the sole source of the system. Stream C appears to meet the criteria of a Type O water under the City's critical areas regulations (25-foot buffer), not physically connected to Type S, F, or N waters by an aboveground channel system, stream, or wetland. Stream C is not identified on City critical areas maps (City of Bellevue 2013b) or WDFW PHS maps (WDFW 2013a).

2.3.2.8. Goff Creek

Anchor QEA staff delineated the OHWM of Goff Creek within the Project area. Goff Creek flows south and southeast through an open channel between commercial development upstream of the Project area. At the downstream end of the delineated reach, Goff Creek flows east through a culvert located beneath 132nd Avenue NE that extends for several hundred feet before becoming an open channel again south of NE Bellevue Redmond Road (Appendix A, Frame 12). An approximately 61-foot reach of Goff Creek was delineated within the Project area. Goff Creek is identified as a Type F water on City critical areas maps (City of Bellevue 2013b). Under the City's critical areas regulations, Type F waters have a 50- or 100-foot protective buffer, depending on site conditions. Because the reach of Goff Creek within the Project area is located within commercial development, site conditions indicate a 50-foot protective buffer is applicable for Goff Creek (City of Bellevue 2013b). This reach of Goff Creek is not identified on WDFW PHS maps (WDFW 2013a).

2.3.2.9. Unnamed Tributary to Kelsey Creek

Within the Project area, the Unnamed Tributary to Kelsey Creek flows south from a culvert located beneath a commercial development parking lot in the ROW on the west side of 136th Place (Appendix A, Frame 13). The first reach of the stream is heavily planted and located between a city sidewalk and a

parking lot. The stream channel has no defined bed and bank due to dense vegetation, but flow within the vegetation was observed. The second reach is in a channelized ditch that flows south into a double culvert. The stream then flows into either a 24-inch pipe within the City storm drain system located within 136th Street or into downstream reaches of the stream on the opposite side of 136th Street. The 24-inch pipe was originally constructed by the City in 1996 as an overflow pipe to address flooding issues. Over time, siltation in the system has raised the stream bed so that the overflow pipe is now the preferential flow path for the stream. Flow still appears to get across 136th Street, either through a City culvert (unable to field locate) or through the roadway subgrade. Results of numerous field visits and discussion with City staff indicate that the overflow pipe receives the majority of the flow from upstream, with a much smaller percentage making it across 136th Street and into the open channel portion of the study area. The overflow pipe empties into the existing stream channel approximately 1,050 linear feet downstream of the 136th Street crossing and downstream of the project area. An approximately 321-foot reach of the stream was delineated within the Project area. The Unnamed Tributary to Kelsey Creek is identified as a Type N water on City critical areas maps (City of Bellevue 2013b). Under the City's critical areas regulations, Type N waters have a 25- or 50-foot protective buffer, depending on site conditions. Site conditions indicate the stream warrants a 50-foot buffer. The reach of the Unnamed Tributary to Kelsey Creek is not identified on WDFW PHS maps (WDFW 2013a).

2.3.2.10. Valley Creek

Valley Creek flows south from two 36-inch culverts located under SR 520, and then flows south to a weir structure at NE 21st Street. Valley Creek flows through the Valley Creek Wetland and is a tributary to Kelsey Creek (Appendix A, Frame 13). Valley Creek appears to meet the criteria of a Type F water under the City's critical areas regulations (50- or 100-foot buffer, depending on site conditions), physically connected to the Mercer Slough (Type S water) by an aboveground channel system, stream, or wetland. Site conditions indicate the stream warrants a 50-foot buffer. Valley Creek is identified on City critical area maps (City of Bellevue 2013b).

2.3.2.11. Coal Creek

Coal Creek is a 7.0-mile-long stream originating in the Newport Hills/Newcastle area that flows into Lake Washington. Habitat conditions in Coal Creek are variable, but typical of most urbanized streams in that habitat conditions have been degraded. According to Kerwin (2001), the primary limiting factors affecting Coal Creek include increased sedimentation, loss of channel complexity, degraded riparian conditions, altered hydrology, and poor water quality (David Evans and Associates 2007). Increased sedimentation is the result of streambank erosion and the occasional catastrophic failure of old coal mine tailings along the steep slopes above the creek (Kerwin 2001). The large sediment load degrades spawning habitat by increasing the amount of fines, thereby decreasing the egg-to-fry ratio, which increases flooding in depositional areas by reducing channel capacity, and has created a large delta that potentially impedes salmonid access during periods of low-flow (David Evans and Associates 2007). Coal Creek is a Type F stream and the area of the mitigation site is undeveloped, the Critical Area Buffer width is 100 feet.

2.3.3 Stream Characteristics

This section provides a summary of the characteristics of stream reaches within the Project area that will be disturbed, or have buffers that will be disturbed, under the proposed Project. Stream characteristics described in this section include hydrologic conditions, channel bed and bank conditions, substrate composition, and riparian vegetation.

2.3.3.1. Wye Creek

Within the Project area, Wye Creek averaged about 3 to 6 feet wide and ranged from about 6 to 24 inches deep at the time of the investigation. The banks are deeply incised, and the top of bank was more than 3 feet above the water line in some areas. The banks showed evidence of scouring, indicating high flow conditions during storm events. Dominant substrate in the channel consisted of a mixture of fine-textured sediment of silt, sand, and small gravels. Large gravels and cobbles were present in patches within the channel. Riparian vegetation was dominated by a dense canopy of native trees and shrubs, with nonnative Himalayan blackberry occasionally present. Small and large branches of woody debris were present within the channel and crossing at the top of the banks a few feet above the water line.

2.3.3.2. Alcove Creek

Within the Project area, Alcove Creek is located on the west side of 112th Avenue SE. The channel averaged about 2 to 6 feet wide and ranged from about 2 to 10 inches deep at the time of the investigation. Bank conditions are not clearly defined in some areas, indicating frequent overbank flooding and variations in flow during storm events. Dominant substrate in the channel consisted of a mixture of fine-textured sediment of silt, sand, and small gravels. Large gravels and cobbles are rare. Riparian vegetation included a mixture of native trees such as black cottonwood and willow, nonnative vegetation such as Himalayan blackberry, and mowed grass associated with residential development. Small and large branches of woody debris were very dense within the channel, accumulating at the culvert at the downstream end of the channel.

2.3.3.3. Sturtevant Creek

Within the Project area, Sturtevant Creek is a linear trapezoidal channel with almost no sinuosity. The channel averaged about 3 to 6 feet wide and ranged from about 6 to 18 inches deep at the time of the investigation. The banks are almost vertical and deeply incised, and the top of bank was more than 2 feet above the water line through most of the reach. The banks showed evidence of scouring, indicating high flow conditions during storm events. Dominant substrate in the channel consisted of a mixture of fine-textured sediment of silt, sand, and small gravels. Large gravels and cobbles were infrequent within the channel. Angular rock was observed within the channel associated with fill material present on both banks. Riparian vegetation at the south end of the channel was dominated by nonnative shrubs such as Himalayan blackberry and Scot's broom, the nonnative grass species reed canarygrass, and weedy herbaceous species. Red alder and black cottonwood trees are present at the north end of the channel near Lake Bellevue. The riparian zone is very narrow, with development

located to the east and railroad tracks located to the west side of the channel. Woody debris within the channel was rare. Significant litter accumulation was present within the channel at the time of the investigation.

2.3.3.4. West Tributary to Kelsey Creek

Within the Project area, the West Tributary to Kelsey Creek channel is linear with very little sinuosity and a narrow floodplain between development. The channel averaged about 4 to 8 feet wide and ranged from about 2 to 18 inches deep at the time of the investigation. The banks are vertical and the top of bank was more than 3 feet above the water line through most of the reach. The banks showed evidence of scouring, indicating high flow conditions during storm events. Dominant substrate in the channel consisted of a mixture of fine-textured sediment of silt, sand, and small gravels. Large gravels and cobbles were present in patches within the channel. Both banks are comprised of fill material, and angular rock was observed within the channel. Riparian vegetation at the south end of the channel was dominated by the nonnative shrub Himalayan blackberry, with red alder, willow, grass, and weedy herbaceous species also present. The riparian zone is very narrow (less than 60 feet), with a parking lot development located near the top of the right bank and parking lots and a building located near the top of the left bank. Small and large woody debris (LWD) associated with alder and willow was present within the channel. Litter accumulation was present within the channel at the time of the investigation.

2.3.3.5. Stream C

Within the Project area, Stream C averaged about 2 to 3 feet wide and ranged from about 2 to 18 inches deep at the time of the investigation. Bank conditions are not clearly visible throughout most of the reach due to dense growth of grass and herbaceous vegetation covering the channel. Dominant substrate in the channel consisted of a mixture of fine-textured sediment of silt, sand, and small gravels. Large gravels and cobbles were rare. Riparian vegetation is dominated by grass and herbaceous species. Tree and shrub vegetation is present on the hillside north of the channel but does not extend to the channel bank for most of the reach. Woody debris was rare within the channel.

2.3.3.6. Goff Creek

Within the Project area, Goff Creek averaged about 3 to 5 feet wide and ranged from about 4 to 14 inches deep at the time of the investigation. Banks are clearly defined and the top of bank ranged from 2 to 3 feet above the water line. Riprap for erosion control is a component of the bank structure. Dominant substrate in the channel consisted of a mixture of silt, sand, small and large gravels, and cobbles. Riparian vegetation is dominated by narrow patches of native and ornamental tree and shrub landscape vegetation associated with the adjacent commercial development and public sidewalk. Woody debris was rare within the channel.

2.3.3.7. Unnamed Tributary to Kelsey Creek

Within the Project area, the Unnamed Tributary to Kelsey Creek stream averaged about 2 to 6 feet wide and ranged from about 4 to 18 inches deep at the time of the investigation. The first reach of the stream is part of a heavily planted buffer mitigation site adjacent to fill prisms associated with a city

sidewalk on the east side and a parking lot on the west side. The stream channel has no defined bed and bank due to dense vegetation, but flow within the vegetation was observed. The second reach is in a channelized ditch with angular rock banks. Riparian vegetation in this reach is mowed grass. Dominant substrate in the channel consisted of a mixture of fine-textured sediment of silt, sand, and small gravels. Large gravels and cobbles were rare. Angular rock is present within the channel. Woody debris was absent within the channel. The Unnamed Tributary to Kelsey Creek appears to meet the criteria of a Type N water under the City's critical areas regulations (50-foot buffer), physically connected to Type S or F waters (Kelsey Creek) by an aboveground channel system, stream, or wetland. The unnamed tributary is not identified on City critical area maps (City of Bellevue 2013b) or WDFW PHS maps (WDFW 2013a).

2.3.3.8. Coal Creek

Coal Creek in the area of the proposed mitigation is generally a glide reach, with a flat bed and high sediment load. There is little roughness (including large wood) in the reach to facilitate the formation of pools and riffles. The riparian conditions include a mix of native and invasive species, including red alder (*Alnus rubra*) and Himalayan blackberry (*Rubus americanus*). Fisheries resources in Coal Creek include anadromous and resident species. The WDFW PHS data obtained for this project reported that fall Chinook salmon (*Oncorhynchus tshawytscha*), coho salmon (*O. kisutch*), sockeye salmon (*O. nerka*), winter steelhead (*O. mykiss*), and resident cutthroat trout (*O. clarki*) utilize Coal Creek (WDFW 2013b).

2.3.4 Stream Impact Assessment

During the course of the Project, portions of four of the eleven stream reaches within the Project area will be permanently filled, relocated, piped, or bridged over (shaded). Seven of the eleven stream reaches will be temporarily impacted. Approximately 6,986 square feet (sf) of stream channel will be permanently disturbed due to guideway and station locations, bridge structures (shading), and streetscape improvements. Approximately 16,774 sf of stream channel will be temporarily disturbed due to construction access and staging needs. The stream buffers of six of the eleven stream reaches within the Project area will be permanently or temporarily removed or altered. Approximately 0.51 acre of stream buffer will be permanently disturbed to construct the Project because of the proposed location of the guideway and stations, utility improvements, streetscape improvements, and areas that prohibit planting because of future improvements. Approximately 0.68 acre of stream buffer will be temporarily disturbed because of the construction access and staging needs, and ground improvements needed for structural stability. Impacts to stream buffers will overlap with the impacts to wetland buffers. Overlapping stream and wetland buffer areas are counted as wetland buffer; therefore, the analysis of stream buffers only includes the stream buffer where there is no overlap with wetland buffers. Wetland buffer impacts are addressed in the Section 2.2.4.

2.3.4.1. Permanent Stream Impacts

Permanent direct impacts from the proposed Project include relocating stream channels, extending culverts, and bridging over streams to construct the Project. Four of the eleven stream reaches in the

Project area will be permanently disturbed, totaling approximately 6,986 sf, because of grading for Project construction. Three of the streams are Type F streams and one is a Type N stream according to the BCC stream typing system. A summary of stream reaches and classifications with permanent impacts under the Project is provided in Table 2-18. Permanent stream impact areas are shown in Appendix B.

Table 2-18 Summary of Permanent Stream Impacts

Stream	Local Stream Rating ¹	Permanent Impacts (sf)	Source of Impact
Wye Creek	Type F	420	Stream relocation; shading due to bridge crossing
Alcove Creek	Type F	236	Shading due to bridge crossing
Sturtevant Creek	Type F	3,443	Relocated to the west to avoid Hospital Station and guideway columns
Unnamed Tributary to Kelsey Creek	Type N	2,887	Channel filled to accommodate guideway, roadway, and sidewalks
Total Permanent Stream Impacts		6,986	

Notes:

1 BCC (City of Bellevue 2013a).

sf = square feet

2.3.4.2. Temporary Stream Impacts

Temporary impacts to stream reaches are anticipated to occur due to vegetation clearing, alterations to existing grades, and shading from temporary structures. Project elements expected to cause temporary construction impacts to streams include construction access routes, temporary public traffic detour routes, staging areas, and utility installations and relocations.

Temporary stream impacts produce short-term loss of stream functions during construction. The extent of short-term degradation would vary depending on the intensity of the temporary impact. Stream reaches temporarily impacted during construction will be restored to their pre-existing conditions or better as described in Section 3.0. Five of the eleven stream reaches in the Project area will incur temporary impacts because of construction activities. This includes 16,774 sf of temporary impacts resulting in a short-term loss of stream functions. A summary of stream reaches with temporary impacts under the Project is provided in Table 2-19. Temporary stream impact areas are shown in Appendix B.

Table 2-19 Summary of Temporary Stream Impacts

Stream	Local Stream Rating ¹	Temporary Impacts (sf)	Source of Impact
Impacts Related to Light Rail Construction			
Wye Creek	Type F	110	Fill and temporary bypass within OHWM due to construction access and circulation parallel to guideway, modifications to channel bottom elevation to establish clearance for future inspections
Alcove Creek	Type F	33	Construction access to build retaining wall
Sturtevant Creek	Type F	382	Realignment of a channelized reach of the stream
West Tributary to Kelsey Creek	Type F	3,814	Channel improvements; construction access bridge over creek (south of guideway)
Stream C	Type O	1,560	Construction access to build Traction Powered Substation (TPSS) station
Unnamed Tributary to Kelsey Creek	Type N	139	Roadway corridor widened to accommodate guideway, roadway, and sidewalks; grading work to restore stream and ditch flows
Subtotal Impacts Related to Light Rail Construction		6,038	
Impacts Related to Mitigation			
Coal Creek	Type F	10,736	Installation of Engineered Log Jams (ELJ) and LWD clusters for habitat improvement/ mitigation
Subtotal Impacts Related to Mitigation		10,736	
Total Temporary Stream Impacts		16,774	

Notes:

1 BCC (City of Bellevue 2013a).

OHWM = ordinary high water mark

sf = square feet

TPSS = transit power substation

2.3.4.3. Permanent Stream Buffer Impacts

Permanent stream buffer impacts will result in a decrease in area adjacent to stream channels, which could result in decreased stream and stream buffer functions within the Project area after construction. Six of the eleven stream channels in the Project area will have permanent stream buffer impacts because of partial filling or grading for Project construction, for a total of 0.51 acres. Overlapping stream and wetland buffer areas are counted as wetland buffer; therefore, the analysis of stream buffers only includes the stream buffer where there is no overlap with wetland buffers. A summary of streams with permanent buffer impacts under the Project is provided in Table 2-20. Permanent stream buffer impact areas are shown in Appendix B.

Table 2-20 Summary of Permanent Stream Buffer Impacts

Stream	Local Stream Rating ¹	Permanent Buffer Impacts (acres) ²	Source of Impact
Wye Creek	Type F	0.09	Shading due to bridge crossing; guideway impacts (retained cut/fill)
Sturtevant Creek	Type F	0.21	Hospital Station, guideway columns, rail/trail envelope, pedestrian bridge
West Tributary to Kelsey Creek	Type F	0.02	(2) proposed storm drain easements/outfalls
Stream C	Type O	0.07	TPSS enclosure, guideway column
Goff Creek	Type F	0.03	Ingress/egress driveway and streetscape improvements for park-and-ride
Unnamed Tributary to Kelsey Creek	Type N	0.09	Expansion of 136th Place NE
Total Permanent Stream Buffer Impacts		0.51	

Notes:

1 BCC (City of Bellevue 2013a).

2 Areas only include stream buffer where there is no wetland buffer overlap. Overlapping buffer areas are counted as wetland buffers and are described in the Section 2.2.4.

TPSS = transit power substation

2.3.4.4. Temporary Stream Buffer Impacts

Project elements expected to cause temporary construction impacts to stream buffers include construction access routes, temporary public traffic detour routes, staging areas, and utility installations and relocations. Four of the eleven stream reaches in the Project area will have temporary stream buffer impacts, for a total of 0.68 acres. This estimate is based on offsets from planned cut and fill and further avoidance and minimization during construction may reduce this impact. A summary of streams with temporary buffer impacts under the Project is provided in Table 2-21. Temporary stream buffer impact areas are shown in Appendix B on Figure 2-1.

In addition to the impacts listed below, constructing stream enhancements at the Coal Creek site will result in temporary disturbance to the Coal Creek buffer. Disturbances include removing vegetation and soil disturbance to provide construction access. Disturbed areas may be used for temporarily stockpiling materials and storing equipment.

Table 2-21 Summary of Temporary Stream Buffer Impacts

Stream	Local Stream Rating ¹	Temporary Buffer Impacts (acres) ²	Source of Impact
Wye Creek	Type F	0.11	Construction access / circulation for bridge, modifications to channel side slopes to establish clearance for future inspections, construction access (vehicular) along east side of guideway
Sturtevant Creek	Type F	0.37	Construction access / circulation, stream construction
West Tributary to Kelsey Creek	Type F	0.12	Construction access / circulation, construction access bridge over creek (south of guideway)
Stream C	Type O	0.08	Construction access, construction of TPSS enclosure and detention vault
Total		0.68	

Notes:

1 BCC (City of Bellevue 2013a).

2 Areas only include stream buffer where there is no wetland buffer overlap. Overlapping buffer areas are counted as wetland buffers and are described in the Wetland Impact Section 2.2.4. Disturbance from constructing stream enhancements at Coal Creek is not included.

TPSS = transit power substation

2.3.5 Stream Regulatory Compliance

Guidance from Ecology and the City was used to determine the stream classifications and appropriate buffer widths. Information and excerpts from the specific guidance language are provided in the following sections.

2.3.5.1 Stream Classifications and OHWM

Streams are classified under the BCC LUC 20.25H.075.A into four categories (Types S, F, N, and O). The definition of the four categories is presented in Section 2.3.1.1. The stream OHWM boundaries were identified consistent with Chapter 90.58 of the RCW and Chapter 173-22 of the WAC. The WAC definition is provided in Section 2.3.1.

2.3.5.2 Stream Buffer Requirements

Appropriate minimum stream buffers were identified according to the current BCC (City of Bellevue 2013a). The BCC identifies minimum protective buffer widths based on the stream rating, as described in Section 2.3.1.1. According to the BCC, stream buffers have been established from the Top of Bank. The City will determine the final stream ratings and minimum buffers. Stream buffer widths based on the local rating are identified in Table 2-17.

2.4 Areas of Special Flood Hazard

2.4.1 Methods

LUC 20.25H.175 describes areas of special flood hazard to include land subject to a 100-year flood, areas identified on the Flood Insurance Rate Map(s) (FIRM), or federal, state, or other sources of information that identify any base flood elevation and floodway data. The City of Bellevue designates all Areas of Special Flood Hazard as critical areas.

A floodplain is defined as the area adjacent to a stream or river that is inundated during the 100-year flood event. The floodway is the channel of a river or stream and overbank areas adjacent to the channel. The floodway carries the bulk of floodwater downstream and is usually the area where water velocities and forces are the greatest and most destructive. The floodway and the adjacent land areas must be reserved in order to discharge the base flood without cumulatively increasing the water surface elevation more than one foot (BCC 20.25H [City of Bellevue 2013a]).

Per LUC 20.25H.180, no use, development or activity may occur in an area of special flood hazard except as specifically allowed under this section of the LUC. Allowable use, development or activity is subject to the performance standards of this section and shall not result in the rise of the BFE, also referred to as the 100-year flood. The City of Bellevue prohibits construction that results in any rise of the base flood; an exception is construction using post and- piling techniques, which is presumed without modeling to cause no rise in the base flood (Ordinance 5680). Fill within the 100-year floodplain must be mitigated by excavating an equal volume of material from within a proximate portion of the Federal Emergency Management Agency (FEMA) floodplain and at a comparable elevation to create “compensatory storage.” Allowable use, development or activity is subject to the performance standards of this section and shall not result in the rise of the BFE, also referred to as the 100-year flood.

The objectives of the special flood hazard assessment were to: (1) identify areas of special flood hazard in the Project area; (2) discuss the effect of the Project on special flood hazard areas; and (3) discuss how both general and specific City performance standards are achieved.

2.4.2 Study Results

The 100-year floodplains, as mapped by FEMA, are shown in Exhibits 4.9-2 through 4.9-4 within Section 4.9 (Water Resources) of the Final EIS. In general, 100-year floodplains that are crossed by the Project are less than 200 feet wide. Some of the smaller creeks and tributaries, including Coal Creek, Goff Creek, Sears Creek, and Sturtevant Creek, do not have formally delineated floodplains. Occasional flooding has been reported on Sturtevant Creek south of Lake Bellevue and on Valley Creek north of the intersection of NE 20th Street and 140th Avenue NE (Watson 2007).

2.4.3 Project Impact on Special Flood Hazards and Mitigation

The East Link Project would generally employ elevated guideways to cross water bodies at a number of locations. Columns to support the elevated guideway will be located outside of stream channel floodways or floodplains.

Using the elevation listed on the associated FEMA FIRM maps, the Sweyolocken mitigation site and the Coal Creek mitigation site are within the 100-year floodplain (Figures 2-3 and 2-4). Minor grading activities (e.g., filling in agricultural ditches, removing culverts) are proposed in these areas, but earthwork improvements within the 100-year floodplain will be balanced or decreased. Based on the Coal Creek Stream Enhancement Project Hydraulic Effects Memorandum (Appendix H) and FEMA Habitat Assessment (Appendix G) developed for the project, there will be no rise in the BFE in either location.

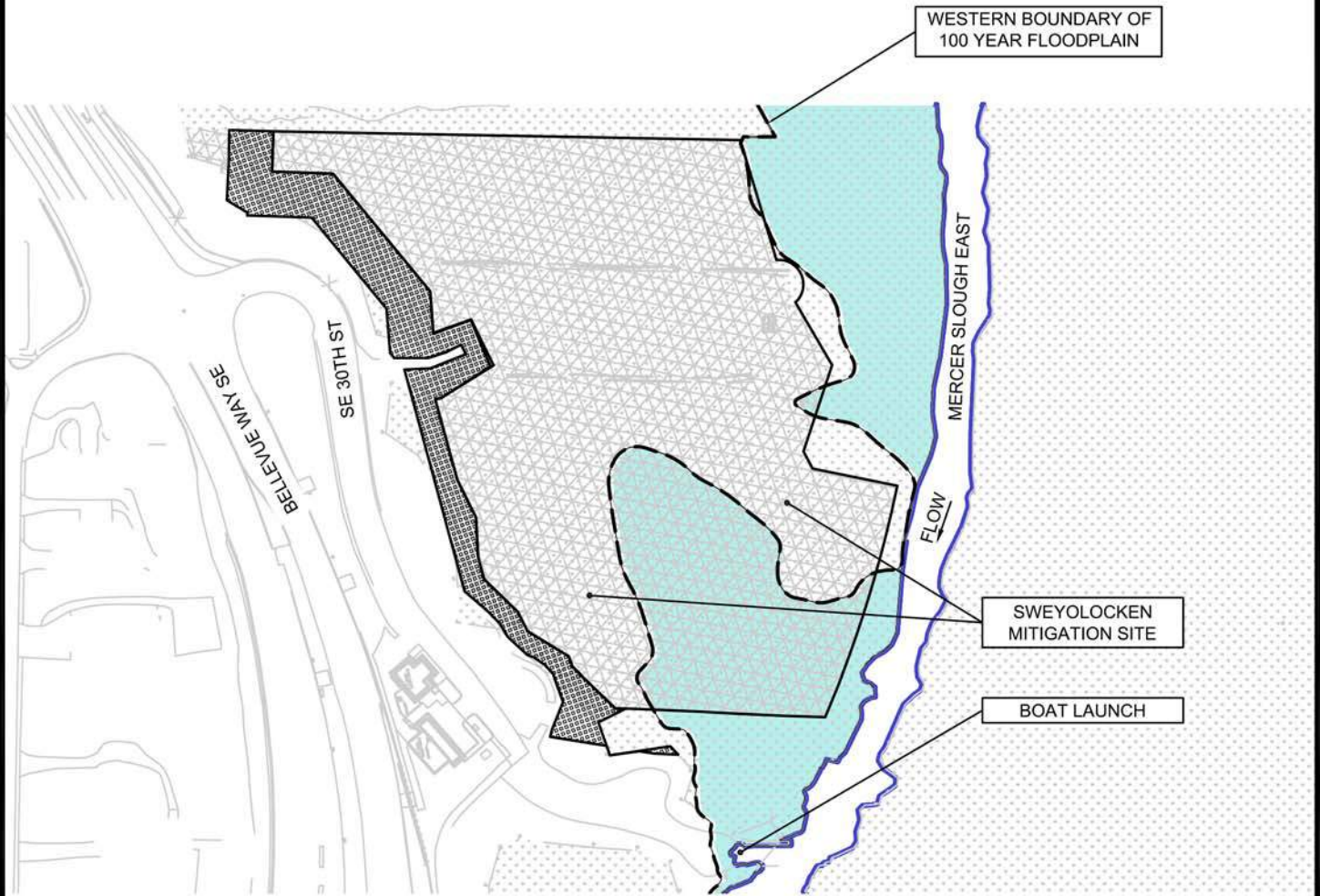

NOTES:

1. EARTHWORK IMPROVEMENTS WITHIN THE 100-YEAR FLOODPLAIN WILL BE BALANCED OR DECREASED. NO RISE IN BASE FLOOD ELEVATION IS ANTICIPATED.

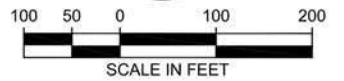

LEGEND

-  100 YEAR FLOODPLAIN BOUNDARY (AT ELEVATION 18.8' PER FIRM MAPS)
-  100 YEAR FLOODPLAIN
-  STREAM OHWM
-  WETLAND ENHANCEMENT
-  BUFFER ENHANCEMENT



EAST LINK EXTENSION
 SOUTH BELLEVUE TO OVERLAKE TRANSIT CENTER
 FIGURE 2-3
 FLOODPLAIN BOUNDARY AT SWEYOLOCKEN

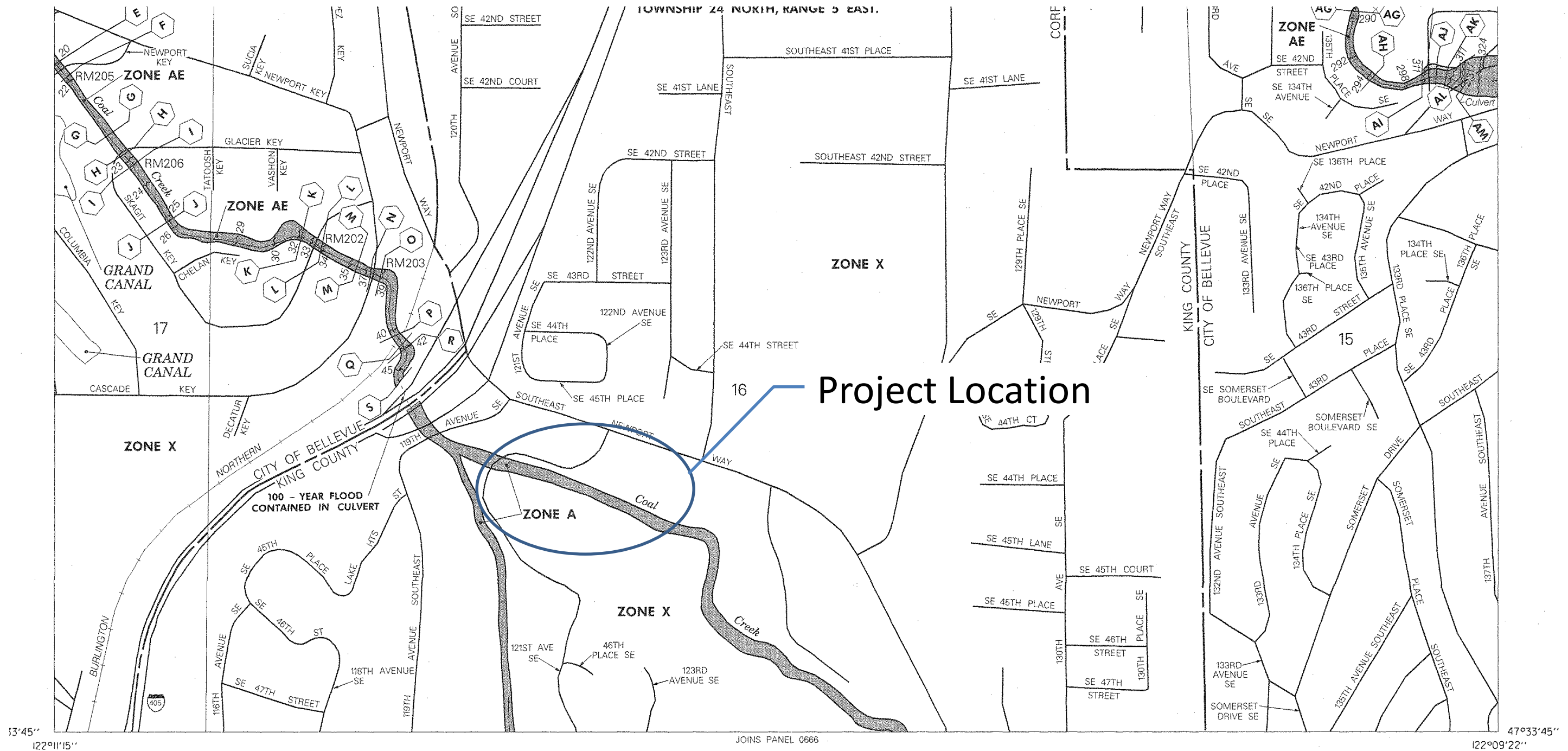

Source: FEMA 1995



FINAL DESIGN PARTNERS.



EAST LINK EXTENSION
SOUTH BELLEVUE TO OVERLAKE TRANSIT CENTER
FIGURE 2-4
FLOODPLAIN BOUNDARY AT COAL CREEK

2.5 Geologic Hazard

The City of Bellevue LUC 20.25H.025 designates three types of geologic hazard areas: landslide hazards, steep slopes, and coal mine hazards. There are no coal mine hazards in the vicinity of the East Link Light Rail Extension within Bellevue.

Steep slopes are defined as a slope of 40 percent or more, with a rise of at least 10 feet, and that is more than 1,000 sf in area (LUC 20.25H.120.A.2). The steep slopes have a critical area buffer width of 50 feet at the top of the slope and a structure setback of 75 feet at the toe of the slope (LUC 20.25H.035).

Landslide Hazards have slopes of 15 percent or more, with 10 feet or more of rise, and display any of the following characteristics (LUC 20.25H.120.A.1):

- Areas of historic failures, including those areas designated as quaternary slumps, earthflows, mudflows, or landslides
- Areas that have shown movement during the Holocene Epoch (past 13,500 years) or that are underlain by landslide deposits
- Slopes that are parallel or subparallel to planes of weakness in subsurface materials
- Slopes exhibiting geomorphological features indicative of past failures, such as hummocky ground and back-rotated benches on slopes
- Areas with seeps indicating a shallow groundwater table on or adjacent to the slope face
- Areas of potential instability because of rapid stream incision, stream bank erosion, and undercutting by wave action

2.5.1 Methods

2.5.1.1. Steep Slopes

Digital terrain models (DTMs) of surface features provided cross-sections of existing ground slopes for the Project track alignments. These were reviewed for all track alignments except for the Downtown Land Use District, where the Critical Areas Overlay District does not apply (LUC 20.25H.005). The DTMs were developed from DTMs prepared for the Preliminary Engineering phase and supplements in the Final Design by additional ground survey. Table 2-22 lists the alignment cross-sections used to identify steep slope areas. All sections are centered on the eastbound track centerline and are either 100 or 150 feet to the left and the right of the track centerline. In addition to the cross-sections, 1-foot-interval contour topographic maps provided slope information for the guideway, station areas, transit power substations, utilities, and other Project structures.

Table 2-22 East Link Alignment Cross Sections for Steep Slope Screening

East Link Section	Contract Package(s) ^{1,2}	Distance Left and Right from EB Track (feet)	Cross Section Frequency (feet)
Lake Washington to 300 block 112th Avenue SE	E320	150	25
300 block 112th Avenue SE to Downtown ³	E330/E335	100	25
Downtown ⁴ to 124th Avenue NE	E335	100	25
124th Avenue NE to NE 20th Street	E340	100	25
NE 20th Street to 148th Avenue NE	E360	100	10

Notes:

- 1 The East Link Project is broken down into individual contract packages. These contract packages will be bid separately and are based upon discrete Project elements and geography. The packages are called E320 (Mercer Slough area), E330 (downtown tunnel), E335 (surface elements from E. Main street station to 124th Ave NE), E340 (Bel-Red section), and E360 (State Route 520 section to Overlake Village Station). The E360 package extends into the City of Redmond. Only the section within the City of Bellevue is described in this table.
 - 2 Contract packages E320, E330/E335, and E340 were 60 percent final design completion when reviewed for steep slope hazards. Package E360 was reviewed for steep slope hazards with the aerial guideway option design at approximately 10 percent completion. This package will be advertised for design-build delivery.
 - 3 The East Link alignment crosses the south boundary of the Downtown Land Use District at the center of Main Street.
 - 4 The East Link alignment crosses the east boundary of the Downtown Land Use District at the I-405 west right-of-way line.
- EB = eastbound

2.5.1.2. Landslide Hazards

Landslide hazards meeting the Critical Areas Overlay District Criteria have not been identified in the Project area.

2.5.2 Study Results

Steep slope criteria were met at 36 locations where Project structures will be located on or below the surface of the steep slope, the steep slope critical area buffer, or the structure setback area. There are other areas of 40 percent or greater slope in the Project vicinity, but these have less than 10 feet of rise or 1,000 sf or less area, and do not meet the steep slope geologic hazard criteria.

Table 2-23 identifies the location of the 36 steep slope areas in relation to the eastbound track centerline stationing. Guideway columns are listed and noted for slope, buffer, and setback location. Most, but not all, of the Project underground construction elements within the slopes, buffers, and setbacks are listed. All areas of the alignment that are on grade or within trenches also include the installation of underground conduit. See Appendix E for figures, including stationing references.

Table 2-23 Geologic Hazard Steep Slopes

App. E Figure ID	EB Track Stationing		Length (feet)	Slope, Buffer and Setback Location	Project Element and Location			
	Start	End			Project Element	Buffer	Slope	Setback
1	421+75	423+75	200	WSDOT I-90 ROW	Column B06 foundation guardrail storm drain	X X	X X	
2	425+00	428+00	300	WSDOT I-90 ROW	Column B08 foundation Column B09L foundation Column B09R foundation Column B10 foundation guardrail storm drain	X X	X X	X X X X
3	433+25	435+25	200	WSDOT ROW City of Bellevue ROW EL-101 700010-0210	Column B15R foundation Column B16 foundation guardrail storm drain	X X X	X X X	• X
4	447+75	450+00	225	EL-110 068540-0035 EL-111 700010-0360 EL-112 068540-0030 EL-113 068540-0025 EL-114 068540-0035	traffic signal foundation sewer roadway pavement/sidewalk catch basin			X X X X
5	450+75	454+25	350	EL-111 700010-0360 064420-0030 EL-114 064420-0035 EL-115 064420-0040 EL-117 064420-0045 EL-118 064420-0050	water line roadway pavement/sidewalk catch basin			X X X
6	453+75	456+75	300	EL-111 700010-0360 EL-123 082405-9278	Column B35L foundation Column B35R foundation Column B36 foundation Column B37 foundation sidewalk light poles utilities soil nails	X X X X	X X	X X X
7	455+00	460+00	500	EL-121 064421-0010 EL-122 064421-0020 EL-124 064421-0100 EL-125 064421-0110 EL-126 064421-0120 EL-127 064421-0130 EL-129 666400-0090 EL-123 082405-9278 EL-128 082405-9278	roadway pavement/ sidewalk track trench retaining wall aerial guideway abutment light poles water line storm drain other utilities			X X X X X X X

App. E Figure ID	EB Track Stationing		Length (feet)	Slope, Buffer and Setback Location	Project Element and Location			
	Start	End			Project Element	Buffer	Slope	Setback
8	457+75	458+50	75	EL-123 082405-9278	roadway pavement/ sidewalk light poles water line storm drain sewer other utilities	X X X X X X	X X X X	X X X X X X
9	460+50	463+50	300	EL-129 666400-0090 EL-130 666400-0100 EL-131 666400-0110 EL-132 666400-0120 EL-128 052405-9254 EL-136 052405-9084	roadway pavement/sidewalk light poles water line storm drain sewer track trench retaining wall track underdrain			X X X X X X X
10	466+00	466+50	50	EL-134 666400-0140 EL-135 666400-0150	roadway pavement/sidewalk light poles water line storm drain other utilities			X X X X X
11	467+75	469+50	175	EL-137 666400-0140 EL-138 666400-0150 EL-136 052405-9084	roadway pavement/curb and gutter light poles water line storm drain other utilities track trench wall and lid track underdrain			X X X X X X X
12	470+25	471+00	75	EL-136 052405-9084	curb, gutter and sidewalk light poles storm drain other utilities track west retaining wall	X X	X X X	X X • X
13	473+50	475+00	150	EL-143 732490-0085 EL-144 052405-9208 EL-136 052405-9084	roadway pavement/curb and gutter light poles water line storm drain other utilities track west wall 8.1B-W track underdrain			X X X X X X X
14	473+75	474+25	50	EL-136 052405-9084 EL-141 066287-0090	curb, gutter and sidewalk light poles storm drain other utilities track west wall 8.1B-W	X X X	X X	X • X

App. E Figure ID	EB Track Stationing		Length (feet)	Slope, Buffer and Setback Location	Project Element and Location			
	Start	End			Project Element	Buffer	Slope	Setback
15	476+00	480+00	400	EL-141 052405-9084	curb, gutter, multi-purpose path light poles storm drain other utilities track west wall 8.1B-W track west wall 8.4A-W Wye Creek crossing structure track underdrain	X X X	X X X	X X X X
16	509+50	510+25	75	EL-166 321060-0220 EL-167 321060-0210	multi-purpose path light pole retaining wall 8.8B-W eastbound track and underdrain westbound track and underdrain	X X	X X	• X
17	517+25	519+75	250	EL-173 322505-9140 322505-9134 322505-9046	curb and gutter multi-purpose path light poles retaining wall 8.8B-W traffic signal pole foundation OCS foundations track and underdrain	X	X X X X	X X X X
18	524+75	525+50	75	EL-181 814630-0050 EL-182 814630-0045 EL-185 140240-0000	wall 9.3A-W and underdrain westbound track and underdrain		X	X
19	534+00	534+75	75	EL-190 814630-0015 EL-191 814630-0010 EL-193 140100-0000	sound wall 9.4A-W platform foundations light pole foundations rockery wall 9.4BW storm drain track and underdrains		X	X X X X
20	611+25	613+25	200	398690-0000 EL-265 109910-0003 EL-266 109910-0025 EL-1000 282505-9038	track ballast walls track and underdrains OCS foundations			X X X
21	612+25	613+75	150	NE 12th Street ROW 282505-9076 282505-9207 282505-9017 EL-265 109910-0003 EL-1000 282505-9038	track ballast walls track and underdrains OCS foundations			X X X
22	638+50	639+00	50	EL-285 282505-9003 EL-286 282505-9296	retained fill track wall 11.5B-W abutment D01 foundation water utility track and wall underdrains	X X X X		

App. E Figure ID	EB Track Stationing		Length (feet)	Slope, Buffer and Setback Location	Project Element and Location			
	Start	End			Project Element	Buffer	Slope	Setback
23	641+50	642+25	75	EL-286 282505-9296 EL-287 282505-9240	Column D04 foundation storm drain	X X		
24	643+75	644+25	50	EL-286 282505-9296 EL-287 282505-9240 EL-289 282505-9193	Column D06 foundation storm drain	X	X	• X
25	647+75	652+75	500	EL-290 282505-9041 EL-291 282505-9178 EL-293 282505-91955	track and underdrains Column D09 foundation Column D10 foundation Column D11 foundation Abutment D12 foundation storm drain electric power wall 11.7A-E and underdrains wall 11.7B-W and underdrains stormwater vault signal house foundation OCS pole foundation stair tower foundation	X X	X X	X X X X X X X X
26	651+25	651+75	50	EL-290 282505-9041 EL-291 282505-9178	Abutment D12 foundation track and underdrains wall 11.7A-E and underdrains wall 11.7B-W and underdrains storm drain	X X X X	X X X	X X X • X
27	656+50	657+00	50	EL-295 282505-9058 EL-296 282505-9159 ELEL-299 282505-9191	eastbound platform foundation westbound track and platform track and platform drains light pole foundations	X X X	X X	X • X
28	656+50	658+25	175	EL-297.1 282505-9243 EL-299 282505-9191	130th Station park and ride Storm drain light pole foundations			X X X
29	695+20	700+40	520	WSDOT SR 520 ROW EL-331 272505-9288 272505-9222 272505-9066	Abutment E01 foundation Column E02 foundation Column E03 foundation Column E04 foundation retaining walls storm drain water utility track and underdrains		X X X X	X X X X X

App. E Figure ID	EB Track Stationing		Length (feet)	Slope, Buffer and Setback Location	Project Element and Location			
	Start	End			Project Element	Buffer	Slope	Setback
30	701+60	715+60	1,400	WSDOT SR 520 ROW 140th Ave NE ROW EL-335 272505-9270 272505-9271 272505-9272 272505-9071	Column E06 foundation Column E07 foundation Column E08 foundation Column E09 foundation Column E10 foundation Column E11 foundation Column E12 foundation Column E13 foundation Column E14 foundation Column E15 foundation Column E16 foundation Column E17 foundation electric power			X X X X X X X X X X X X X X
31	714+40	715+60	120	WSDOT SR 520 ROW EL-337 272505-9103	Column E17 foundation	X		
32	717+30	719+00	170	WSDOT SR 520 ROW NE 24th Street ROW EL-338 272505-9025	Column E19 foundation Column E20 foundation TPSS enclosure signal house foundation water utility electric power sanitary sewer	X X X X X	X	
33	720+00	722+00	200	NE 24th Street ROW EL-338 272505-9025	[no Project construction]			
34	720+70	723+40	270	WSDOT SR 520 ROW EL-338 272505-9025	Column E22 foundation Column E23 foundation Column E24 foundation drainage swale	X X X	X X X	
35	727+80	728+80	100	WSDOT SR 520 ROW	Column E28L foundation	X		
36	730+60	732+00	140	WSDOT SR 520 ROW	[no Project construction]			

Notes:

EB stationing is the horizontal alignment distance along the eastbound track. A full station is 100 feet. For example, the horizontal distance between stations 510+50 and 514+75 is 425 feet.

Aerial guideway column IDs ending in "L" are the left side of two-column supports looking eastbound. IDs ending in "R" are the right side of two-column supports looking eastbound.

EB = eastbound

ROW = right-of-way

TPSS = transit power substation

WSDOT = Washington State Department of Transportation

2.5.3 Project Impact on Geologic Hazards

The Project is self-mitigating with respect to steep slopes. Retaining walls and slopes minimize the Project footprint and extent of topography modification. Structure design in steep slope areas, buffers, and structures setbacks is based on geotechnical analyses and recommendations that avoid risk to the light rail transit facilities, users, and neighboring properties.

2.6 Probable Cumulative Impacts

Construction and operation of the East Link Project may coincide with other development projects that also affect the critical areas identified in this report. However, adverse cumulative impacts are not anticipated due to regulatory considerations, habitat enhancement efforts for natural resources in the Project area, and Sound Transit's commitment to no net loss of wetland function and area.

2.6.1 Wetlands, Streams, and Habitat Associated with Species of Local Importance

The East Link Project Final EIS noted that other planned regional transportation projects and the City's Downtown Implementation Plan could contribute to cumulative impacts on upland habitat, streams, and wetlands in the Project area in conjunction with the Project. These impacts may include vegetation and tree removal, filling or altering wetlands, disturbance to stream channels, removal of riparian habitat, and increases in pollution-generating impervious surfaces. These changes, along with additional urban development, continue to reduce remaining available high-quality nesting and foraging areas for wildlife species present in the area, which provide habitat for species of local importance.

Positive impacts may result from efforts to enhance the Bear Creek and Kelsey Creek watersheds that cross through and extend beyond the Project vicinity. The City has adopted the Bel-Red Plan, which has an element devoted to "The Great Streams Strategy." This strategy involves stream enhancements that include removing culverts where possible, removing impassable fish barriers, planting riparian vegetation along stream banks, and generally improving stream quality. These efforts are focused on Goff Creek and the West Tributary of Kelsey Creek, both of which cross Mercer Slough Nature Park.

The Project and other state and locally permitted projects incrementally provide net benefit to stream suitability for fish. These projects are required to mitigate impacts on streams, wetlands, and high-value habitats in accordance with federal, state, and local regulations. Mitigation measures implemented as a result of the East Link and other projects will benefit fish and wildlife habitat for species of local importance when compared to existing conditions and improve conditions for federally listed threatened or endangered species. In all wetland, stream, and buffer areas along the Project corridor, native species are proposed to replace invasive species where feasible. The consistent goal throughout is to increase the amount of forested areas, with an emphasis on evergreen species to assist in increasing ecological functions and enhancing the landscape character. Also, with regard to wetland and stream impacts, Sound Transit has committed to achieving no net loss of function and area on a Project-wide basis, and therefore, would not have a lasting cumulative impact on wetlands and streams.

2.6.2 Geology and Soils

The Project will not adversely impact geologic conditions in the Project area. Additional development in the area would increase the amount of infrastructure placed in localized geologically sensitive areas such as steep slopes or seismic hazard areas. However, all of these projects must be constructed in accordance with state and local laws that require design and construction to meet seismic standards; therefore, a cumulative impact is not expected.

2.6.3 Floodplains

Construction within areas of special flood hazard, as well as new impervious surfaces added by the Project and other reasonably foreseeable future actions would include appropriate stormwater control and quality treatment in accordance with Ecology regulations. This mitigation would improve the treatment of some existing stormwater drainages and thus provide an overall cumulative benefit for water quality over existing conditions.

3.0 Mitigation

This section describes the compensatory mitigation measures for those impacts that cannot be addressed through avoidance and minimization or through the restoration of temporarily disturbed areas. Mitigation is proposed to address potential impacts to critical areas such as steep slopes, wetlands, streams, and their buffers. The Project has been designed to mitigate for potential impacts to areas of geologic hazard. No further mitigation is provided for these areas.

The mitigation for wetland, stream, and buffer impacts will occur at five sites (Sweyolocken, Mercer Slough/Bellefield, Sturtevant Creek, West Tributary, and Coal Creek). All but the Coal Creek site are adjacent to the rail alignment where impacts occur (see Figure 3-1). All but one of the mitigation sites are publically owned. The Mercer Slough/Bellefield site is the only one that is privately owned. Sound Transit will construct all projects concurrently with the other elements of the Project. All five sites will be protected in perpetuity through existing or new covenants/Native Growth Protection Areas, Easements, or Tracts. Areas within these covenants are shown in Appendices C and D. These areas will be monitored and maintained by Sound Transit for a minimum of 5 years to insure that the vegetation communities are established, and that the mitigation goals, objectives, and performance standards are met. The protective covenants will ensure that, once established, the ecological functions of the sites are protected from future land use actions.

Mitigation for potential impacts from tree and/or vegetation removal on steep slopes affecting habitat associated with species of local importance will be addressed with additional tree plantings within the affected area, as well as within the Sweyolocken, Mercer Slough/Bellefield, and West Tributary mitigation sites. These three mitigation sites are also adjacent to impacted steep slope and steep slope buffers associated with habitat of species of local importance. In each instance, nonnative plants will be replaced with native plants and plant diversity will be increased.

The Coal Creek project site is less than 2 miles from the rail alignment. The work at this site will be implemented within 1 year of the impacts to the Unnamed Tributary to Kelsey Creek.

The mitigation sites were selected based on their ability to replace the ecological functions that will be impacted by the Project. The wetland impacts and proposed mitigation are shown in Table 3-1 below. Temporary wetland impacts at the Coal Creek mitigation site are not included in this table because the restoration is anticipated to be completed immediately following disturbance (less than 12 months total time). Sound Transit will monitor and maintain all mitigation sites (see Section 3.5).

Table 3-1 Project Wetland Impacts and Proposed Mitigation Summary

Wetland Category	Drainage Sub-basin	Vegetation Conversion/ Temp Impacts (Acres)	Mitigation Type	Mitigation Ratio ¹	Mitigation Requirement ¹ (Acres)	Proposed Mitigation by Type and Site
Permanent Impacts to Wetlands by Basin and Wetland Rating¹						
Category II	Mercer Slough	0.23 ²	Rehabilitation	6:1	1.38	Rehabilitation at Sweyolocken
Category III	Mercer Slough	0.13	Creation	2:1	0.26	Creation at West Tributary
Category II	West Tributary	0.01	Creation	3:1	0.03	Creation at West Tributary
Category III	West Tributary	0.05	Creation	2:1	0.10	Creation at West Tributary
Category III	Valley Creek	0.01	Creation	2:1	0.02	Creation at West Tributary
Subtotal Permanent Impacts to Wetlands		0.43		Subtotal	1.38 Acres of Rehabilitation 0.41 Acre of Creation	
Temporary Impacts to Wetlands by Basin and Wetland Rating¹						
Category II	Mercer Slough / West Tributary	0.34	Enhancement	3:1	1.02	Enhancement at Sweyolocken
Category IV	Sturtevant Creek	0.04	Enhancement	1.5:1	0.06	Enhancement at Sweyolocken
Subtotal Temporary Impacts to Wetlands		0.38		Subtotal	4.78 Acres of Enhancement	
Permanent Conversion of Wetland Vegetation Type by Basin and Wetland Rating¹						
Category II	Mercer Slough/ Valley Creek	0.33	Enhancement	6:1	1.98	Enhancement at Sweyolocken
Category III	Sturtevant Creek/ West Tributary/ Valley Creek	0.43	Enhancement	4:1	1.72	Enhancement at Sweyolocken
Subtotal Permanent Conversion of Wetland Vegetation		0.76				
TOTAL		0.43 Acre	Permanent Impacts	TOTAL	4.78 Acres of Enhancement 1.38 Acres of Rehabilitation 0.41 Acre of Creation	
		0.38 Acre	Temporary Impacts			
		0.76 Acre	Permanent Vegetation Conversion			

Notes:

1. Mitigation ratios and requirements provided here are based on Washington Department of Ecology, US Army Corps of Engineers Seattle District, and Environmental Protection Agency, Region 10 guidance (Ecology et al. 2006) except for permanent vegetation.

2. This includes .02 acre of impact from pin piles, which is not regulated by the U.S. Army Corps of Engineers.

The overall wetland mitigation approach is further summarized in Table 3-2, which demonstrates that required mitigation ratios are being met or exceeded. Surplus mitigation may be applied to address unforeseen or additional unavoidable or accidental impacts that occur during construction of the Project. The specific functional lift of wetland areas being enhanced and rehabilitated is described in Section 3.3.

Table 3-2 Proposed Project Wetland Mitigation Summary Compared to Regulatory Requirements

Required Mitigation ¹	Proposed Mitigation
4.78 Acres of Enhancement	5.12 Acres of Wetland Enhancement ² (4.87 at Sweyolocken, 0.14 at Bellefield South, 0.07 at Bellefield North, and 0.04 at Kelsey West Tributary Stream Wetland)
1.38 Acres of Rehabilitation	1.50 Acres of Rehabilitation at Sweyolocken
0.41 Acre of Creation	0.55 Acres of Creation at West Tributary

Note:

1 Mitigation requirements provided here are based on Washington Department of Ecology, US Army Corps of Engineers Seattle District, and Environmental Protection Agency, Region 10 guidance (Ecology et al. 2006).

Stream impacts will be mitigated on site to the extent possible. Permanent impacts to Wye Creek and Alcove Creek are relatively minor and related to shading of the water by the guideway. Wye Creek impacts also include mitigation activities associated with relocating and restoring the creek channel outside the shading from the guideway. Impacts to Wye Creek and Alcove Creek will also be mitigated through riparian buffer enhancements. Sturtevant Creek will be realigned with a new channel that provides improved ecological function over the existing channel. The culvert downstream of the open channel of Sturtevant creek will be shortened by 13 feet, but the existing fish passage barrier will remain. Removal of the barrier was found to be impracticable due to the structure's importance in maintaining flood protection to Lake Bellevue and Sturtevant Creek downstream of the site. In this instance, installing a fish-passable culvert or fish ladder that would be directly connected to an existing, non-fish-passable culvert would not provide meaningful environmental benefits. Furthermore, attempting to install a fish-passable culvert in this location would likely conflict with any future design to make the entire system fish passable based stream gradient and existing infrastructure and utility conflicts. To mitigate for the perpetuation of this barrier, Sound Transit will provide a new, fish-passable culvert under NE 16th Street on Goff Creek that will be suitable for use in a proposed future realignment and restoration of Goff Creek.

The decision to provide fish passage at Goff Creek was made due to the existence of plans for restoration of the Goff Creek/ Kelsey Creek system (Bel-Red Plan) and the fact that no similar plan exists to restore fish passage to Sturtevant creek downstream of the proposed impacts. The City of Bellevue is actively restoring fish passage in the West Tributary/Goff Creek basin and the barriers to fish migration downstream of NE 16th Street on Goff Creek are likely correctable. A review of natural resource restoration opportunities in the Bel-Red Corridor was conducted for the City by Herrera Environmental Consultants in 2006, and rated Goff Creek (along with Sears Creek) as having the second highest

opportunity for rehabilitation of all the streams in the Bel-Red Corridor (Herrera 2006). Sturtevant Creek is not likely to have migratory access restored all the way to Lake Bellevue before full fish passage on Goff Creek is restored to NE 16th Street. Existing culverts including one under I-405 will be extremely challenging to correct. Additional mitigation for impacts to Sturtevant creek will be provided by enhancement of a portion of the West Tributary to Kelsey Creek. Finally, impacts to the Unnamed Tributary to Kelsey Creek will be mitigated by stream enhancement on Coal Creek. Impacts to the Unnamed Tributary of Kelsey Creek occur less than 600 feet from the headwater of that system, and upstream of the impact, the majority of the stream is piped, or the habitat is otherwise limited and degraded in a ditch formation between roads and development. In addition, there is no documented fish use of the Unnamed Tributary of Kelsey Creek (WDFW 2013a and 2013b). In contrast, the Coal Creek mitigation site supports Chinook, rainbow, and cutthroat trout, and coho, sockeye, and steelhead (WDFW 2013a and 2013b), and there are several miles of upstream habitat that flow through healthy forested riparian habitat in open space conservation. These impacts and the proposed mitigation are summarized in Table 3-3 below.

Table 3-3 Project Stream Impacts and Proposed Mitigation

Stream	Local Stream Rating	Permanent Impacts (sf)	Proposed Mitigation
Wye Creek	Type F	420 (shading from guideway bridge and relocation)	420 sf of restored (relocated) Wye Creek
Alcove Creek	Type F	236 (shading from guideway bridge)	62 sf of stream daylighting at Wye Creek and 45 sf of restored (relocated) Wye Creek
Sturtevant Creek	Type F	3,443 (relocation) (247 shading from pedestrian bridge) Perpetuating existing fish passage barrier	3,500 sf of restored (relocated) Sturtevant Creek 3,814 sf of Stream Channel Enhancement on West Tributary to Kelsey Creek Installation of fish passage culvert on Goff Creek
Unnamed Tributary to Kelsey Creek	Type N	2,887 (from at-grade guideway)	10,736 sf of Stream Channel Enhancement on Coal Creek.

Note:

sf = square feet

In addition to the permanent impacts above, permanent, unavoidable impacts to stream and wetland buffers will occur. Restoration of these buffer areas is impracticable due to interference with new infrastructure, such as the guideway or other Project appurtenances. These will be mitigated by enhancement of existing buffers that currently have low function. In most cases, function will be restored by replacing existing invasive species with high-value native vegetation communities. Tables 3-4 and 3-5 describe the permanent impacts to wetland and stream buffers that will be mitigated at other locations along the Project corridor. As presented in Tables 3-4 and 3-5, permanent impacts to

wetland and stream buffers will be mitigated at a 1:1 ratio through buffer enhancement and/or creation along the project corridor. The total amount of wetland and stream buffer impacts is 5.62 acres. 5.93 acres of buffer will be enhanced or created for a total of 0.31 acre of extra buffer mitigation. This extra buffer mitigation will be used to address unanticipated changes to impacts that may occur during construction.

Table 3-4 addresses the 0.66 acre of Mercer Slough wetland buffer impact that is categorized as “intensification of use”. This impact is the result of the existing paved parking lot within the buffer being converted to a parking structure for the South Bellevue Station. Impacts related to this intensification of use include potential increases in noise and light on adjacent natural areas of the Slough. Mitigation for this impact will be accomplished through design elements of the station and landscaping around the perimeter of the station. Specific mitigation elements include the following:

- Protecting existing trees around the station area.
- Removing invasive species and increasing the amount native evergreen tree species around the station to improve existing habitat.
- Adding shields to light fixtures and/or reduced footcandles on lights where possible.

Table 3-4 Summary of Permanent Wetland Buffer Impacts

Wetland Name	State (Ecology) and Local (Bellevue) Rating	Permanent Buffer Impacts (acres)	Mitigation
Mercer Slough	II	4.10 ¹	Buffer Enhancement and Creation
Alcove Creek	II	0.09	
Bellefield South	II	0.20	
Bellefield North	II	0.24	
Central Lake	III	0.05	
BNSF West	III	0.09	
BNSF East	III	0.14	
BNSF Northeast	III	0.04	
Kelsey West Tributary Pond	II	0.13	Buffer Enhancement and Creation
SR 520 West	III	0.01	
Valley Creek	II	0.01	
Total Permanent Wetland Buffer Impacts/Restoration		5.11	5.11 Acres

Note:

1 0.66 acre of Mercer Slough buffer impact is due to the intensification of use when the existing parking lot within the buffer is converted to a parking structure for the South Bellevue Station.

Table 3-5 Summary of Permanent Stream Buffer Impacts

Stream	Local Stream Rating ¹	Permanent Buffer Impacts (acres) ²	Mitigation
Impacts Related to Light Rail Construction			
Wye Creek	Type F	0.09	Buffer Enhancement and Creation
Sturtevant Creek	Type F	0.21	
West Tributary to Kelsey Creek	Type F	0.02	
Stream C	Type O	0.07	
Goff Creek	Type F	0.03	
Unnamed Tributary to Kelsey Creek	Type N	0.09	
Total Permanent Stream Buffer Impacts		0.51	0.51 Acre³

Notes:

1 BCC (City of Bellevue Code 2013a).

2 Areas only include stream buffer where there is no wetland buffer overlap. Overlapping buffer areas are counted as wetland buffers and are described in the Wetland Impact Section 2.2.4.

3 Some area serves as overlapping wetland and stream buffer mitigation.

3.1 Mitigation Sequence

3.1.1 Measures to Avoidance and Minimization Impacts

The ROD and subsequent adoption of the alignment by the Bellevue City Council makes all avoidance of critical areas impossible. Therefore, the Sound Transit engineering team has worked collaboratively within this defined alignment to avoid and minimize proposed impacts. During the preliminary design process, Sound Transit made adjustments to avoid or minimize impacts to natural resources, including wetlands and streams and their associated buffers. When a wetland or stream appeared to be located within the Project footprint, engineers changed the footprint to avoid the wetland or stream, or, if the wetland or stream could not be avoided, it was determined how much direct wetland, stream, and buffer area would be affected due to Project construction.

The following avoidance and minimization measures have been incorporated into the Project design to allow Sound Transit to meet the transportation Project needs, without directly affecting important natural resources:

- Wetlands and streams are avoided where practicable.
- Associated Project facilities, such as stormwater treatment systems, staging areas, and access roads, are located outside of the identified critical areas, where practicable.
- The Project footprint has been minimized (e.g., using retaining walls instead of fill slopes and using existing roads and thereby limiting the amount of new impervious surfaces required).
- Accommodations have been made to allow for future stream passage improvements at stream crossings where fish are not currently present, but could be in the future if stream restoration and fish passage improvements are completed by others.

- Removal of vegetation within areas (including steep slopes) that support habitat for species of local importance will be minimized and functional replacement will occur through on- and off-site enhancement measures.

Sound Transit has identified specific BMPs and other measures that will be incorporated into the construction specifications for the Project. BMPs will be implemented during construction and operation of the Project to minimize sedimentation to wetlands and streams and contamination associated pollutants in stormwater runoff.

- Sound Transit has met with, and will continue to coordinate with federal, state, and local agencies to identify mitigation priorities and options for avoiding or minimizing wetland and stream impacts, and to compensate for any impacts.

Specific avoidance and minimization measures include the following:

- Installing a retaining wall at 15th Street to avoid additional impacts to Bellefield South and Bellefield North wetlands
- Shifting the alignment to south and elevating the guideway to have a minimum 15-foot clearance, to minimize impacts to Kelsey West Tributary Pond wetland
- Providing a fish passable crossing under NE 16th Street for the future daylighting of Goff Creek (by others)
- Providing accommodations for future fish passage by others at the crossing of the unnamed tributary to Kelsey Creek (which is not currently fish passable)
- Pipe discharge locations are dictated by the need to meet a certain topographic elevation, and in some cases, that impacts wetlands. Avoidance and minimization will occur where possible by either moving discharge locations or converting the design into a swale (versus pipe).
- The existing detention water quality pond at South Bellevue station was constructed in 1980. Due to the reconstruction of the site, this pond will be modified to accommodate the new stormwater requirements. The pond will be expanded towards existing parking lot, within the wetland buffer.

The avoidance and minimization measures above resulted in the avoidance of impacts as described below:

- There are no proposed permanent wetland impacts to 15 of the 22 wetlands in the Project area.
- There are no permanent wetland buffer impacts to ten of the 22 wetlands in the Project area.
- There are no temporary wetland impacts to 16 of the 22 wetlands in the Project area.
- There are no temporary wetland buffer impacts to 12 of the 22 wetlands in the Project area.
- There are no proposed permanent stream impacts to seven of the 11 streams in the Project area.
- There are no permanent stream buffer impacts to five of the 11 streams in the Project area.

- There are no temporary stream impacts to five of the 11 streams in the Project area.
- There are no temporary stream buffer impacts to seven of the 11 streams in the Project area.

3.1.2 Measures to Rectify and Restore Impacts

After avoiding and minimizing impacts, the next mitigation sequencing activity requires restoring the impacted resource(s). Therefore, all wetland, stream, and buffer areas temporarily affected from construction activities will be restored within the Project area. The goal is to restore them to previous or better conditions. Tables 3-6 and 3-7 describe the wetlands and wetland buffers that will be temporarily impacted and restored. Tables 3-8 and 3-9 describe the streams and stream buffers that will be temporarily impacted and restored on site.

Table 3-6 Summary of Temporary Wetland Impacts

Wetland Name	Size (acres)	State (Ecology) and Local (Bellevue) Rating	Temporary Impacts (acres)	Proposed Restoration
Impacts Related to Light Rail Construction				
Mercer Slough	350 ¹	II	0.22	Revegetation
Alcove Creek	0.64 ¹	II	0.01	
Bellefield South	0.29	II	0.04	
Bellefield North	0.11	II	0.02	
North Lake	0.04	IV	0.04	
Kelsey Creek West Tributary Pond	5.98 ¹	II	0.05	
Subtotal Impacts Related to Light Rail Construction			0.38	
Impacts Related to Mitigation				
Wetland D	> 1.00 ²	II	0.10	Revegetation
Subtotal Impacts Related to Mitigation			0.10	
Total Temporary Wetland Impacts			0.48	

Notes:

1. Approximate total wetland area, including delineated areas. Wetland areas outside the Project area that were not delineated are estimated based on observations during the field investigation and aerial photograph analysis.

2. Estimated as "greater than one-acre" by David Evans and Associates, Inc. (2007).

Table 3-7 Summary of Temporary Wetland Buffer Impacts

Site	Drainage Sub-basin	State (Ecology) and Local (Bellevue) Rating	Temporary Buffer Impact ¹ (acres)	Proposed Restoration
Mercer Slough	Mercer Slough	II	4.43	Revegetation
Alcove Creek	Mercer Slough	II	0.08	
Bellefield South	Mercer Slough	II	0.01	
Bellefield North	Mercer Slough	II	0.04	
South Lake	Sturtevant Creek	III	0.27	
Central Lake	Sturtevant Creek	III	0.09	
BNSF East	West Tributary	III	0.01	
Kelsey West Tributary Pond	West Tributary	II	0.36	
SR 520 West	Valley Creek	III	0.55	
Valley Creek	Valley Creek	II	0.27	
Total Temporary Wetland Buffer Impacts:			6.11	

Note:

1 This does not include temporary disturbance for stream enhancements for Coal Creek.

Table 3-8 Summary of Temporary Stream Impacts

Stream	Local Stream Rating ¹	Temporary Impacts (sf)	Proposed Restoration
Impacts Related to Light Rail Construction			
Wye Creek	Type F	110	Remove Fill and bypass, restore channel
Alcove Creek	Type F	33	Remove Fill and bypass, restore channel
Sturtevant Creek	Type F	382	Remove Fill and bypass, restore channel
West Tributary to Kelsey Creek	Type F	3,814	Remove Construction access bridge and bypass, restore channel
Stream C	Type O	1,560	Remove Fill and bypass, restore channel
Unnamed Tributary to Kelsey Creek	Type N	139	Restore channel
Total Impacts Related to Light Rail Construction		6,038	

Stream	Local Stream Rating ¹	Temporary Impacts (sf)	Proposed Restoration
Impacts Related to Mitigation			
Coal Creek	Type F	10,736	Installation of Engineered Log Structures and LWD clusters
Total Impacts Related to Mitigation		10,736	
Total Temporary Stream Impacts		16,774	

Notes:

1 BCC (City of Bellevue 2013a).

sf = square feet

Table 3-9 Summary of Temporary Stream Buffer Impacts¹

Stream	Local Stream Rating	Temporary Buffer Impacts (acres)	Proposed Restoration
Wye Creek	Type F	0.11	Revegetation
Sturtevant Creek	Type F	0.37	
West Tributary to Kelsey Creek	Type F	0.12	
Stream C	Type O	0.08	
Total Temporary Stream Buffer Impacts:		0.68	

Note:

1 This does not include temporary disturbance for stream enhancements for Coal Creek.

3.1.2.1. Wetland and Buffer Restoration

Temporary impacts to critical areas located along the Project corridor—within the Sturtevant, West Tributary Kelsey Creek, and Valley Creek sub-basins—will be restored to previous conditions or better after construction. Wetland enhancement in these areas will cover 5.12 acres, and stream and wetland buffer enhancement will cover 5.93 acres.

Specific restoration activities include removing all geotextile fabric and temporary fill material used for construction staging or access roads from all wetland and buffer areas. Grades will be restored to pre-Project conditions, and the soils will be loosed or loosened to restore soil condition and wetland hydrology. Soil amendments or topsoil will be added where necessary to restore soil fertility, porosity, and texture. The contractor will be required to meet soil decompaction levels that will be suitable for plant establishment.

Native plant communities will be selected for each site to meet site conditions (i.e., sunny, shady, wet, or dry) and growth preferences (i.e., tall or short tree, shrub, or groundcovers). Many adjacent buffer areas along the corridor are currently dominated or infested with invasive species, such as Himalayan blackberry. Robust communities of nonnative invasive species located immediately adjacent to temporarily affected areas will be cleared so as not to interfere with long-term maintenance and

monitoring. It is expected that there will be an increase in functions and values in many areas by replacing these monocultures of nonnative vegetation with native vegetation communities.

3.1.2.2. Steep Slope Restoration Associated with Habitat of Species of Local Importance

As mentioned above, there are nine steep slope areas that will be impacted by the Project and are within or adjacent to habitats for species of local importance. The following discussions provide specific details about the vegetation that will be impacted and how those impacts will be mitigated.

- **Steep slope area #3** (see Figure 2 in Appendix E): This steep slope is located between the I-90 off ramp and SE 30th Street with a small area of the toe of slope setback in the Mercer Slough wetland buffer. Most of the construction in the steep slope setback is within the SE 30th Street paved area. Approximately 4 to 5 significant trees will be removed from this steep slope due to conflicts with light rail operations, but none of them are within the wetland buffer. Some clearing of native, nonnative, and invasive shrubs will be required in the steep slope and its toe of slope setback, but those areas will be replanted with native vegetation after construction. There will not be a significant impact to habitat associated with species of local importance.
- **Steep slope area #6** (see Figure 3 in Appendix E): This steep slope is located east of Bellevue Way SE between the South Bellevue Station and the Blueberry Farm. The toe of slope setback extends into the Mercer Slough wetland and wetland buffer. Trees and other vegetation will be removed on the entire steep slope area under the guideway. Portions of the toe of slope setback area will also have tree and vegetation removal from anticipated construction access needs. All cleared areas will be replanted with native vegetation. The light rail guideway will be elevated at this location and plantings under the guideway and within the VCZ will consist of native shrubs where possible. Native trees will be planted in cleared areas outside of the VCZ. All of the invasive species in this area will be removed and replaced with native trees, shrubs, and groundcovers, which will result in better habitat diversity and an insignificant impact to habitat associated with species of local importance.
- **Steep slope area #8** (see Figure 3 in Appendix E): This steep slope area is located along about 80 feet of the east sidewalk on Bellevue Way SE near the Blueberry Farm parking lot. A small portion of the steep slope is within the Mercer Slough wetland buffer. This buffer area will be cleared during construction but will be replanted with native scrub-shrub low (SSBL) buffer plantings. The SSBL plantings will result in a lower understory planting than what currently exists, but the final design will replace the invasive species with all native species helping to increase habitat diversity. There will not be a significant impact to habitat associated with species of local importance.
- **Steep slope area #12** (see Figure 4 in Appendix E): This steep slope area is just north of the Winters House and runs about 80 feet along the east sidewalk of Bellevue Way SE. Nearly all of the slope area will be replaced by a trench for both tracks. Most of the toe of slope setback area

is in both the Mercer Slough wetland and wetland buffer and will be impacted by storm drains and construction access. Steam A is also within the toe of slope setback area. Restoration plantings immediately east of the trench east wall within the vegetation clear zone will be scrub-shrub wetland (SSW) in the Stream A corridor and scrub-shrub buffer (SSB) in the Mercer Slough wetland buffer. Outside of the vegetation clear zone, plantings will be forested buffer (FB) and forested wetland (FW). To mitigate for the vegetation impacts in the wetland buffer, the design includes “infill planting” directly north of this area, which will remove invasive species such as nonnative laurel, Himalayan blackberry, and English ivy, all of which are hindering the ability to sustain a healthy ecosystem. Replacing the invasive species with native vegetation will assist in increasing habitat diversity. There will not be a significant impact to habitat associated with species of local importance.

- **Steep slope area #14** (see figures 4 and 5 in Appendix E): This steep slope area is located along the east side of Bellevue Way SE near the 112th Avenue SE intersection. The guideway will be in a trench in this location, similar to steep slope #12. Most of the steep slope will be replaced by the track trench. The toe of slope setback will be temporarily impacted by proposed storm drains and construction access. A small area between the Bellevue Way SE sidewalk and the trench west retaining wall will be restored with SSB planting. Plantings immediately east of the trench east wall will be SSW planting in the Mercer Slough wetland and SSB planting in the Mercer Slough wetland buffer. Outside of the vegetation clear zone, plantings will be FB and FW, which will assist in restoring the forested conditions in this area. Some of the wetland buffer away from the construction impacts will have infill planting to replace invasive species with native species, thereby improving habitat conditions. The restoration planting and infill planting in this area will mitigate for the permanent vegetation impacts, and overall there will not be a significant impact to habitat associated with species of local importance.
- **Steep slope area #15** (see figure 5 in Appendix E): This steep slope area is located on the east side of the intersection of Bellevue Way SE and 112th Avenue SE. The slope is east of the guideway. The guideway will be in a trench and at-grade in the toe of the slope setback area. The Wye Creek crossing will also be in the toe of slope area. The entire slope is within the Mercer Slough wetland buffer and the Wye Creek buffer. . The top of slope buffer is in the sidewalk and street pavement and landscaping. The toe of slope setback is mostly in the Mercer Slough wetland or wetland buffer and the Wye Creek buffer. The guideway will permanently impact some trees and other vegetation within the Mercer Slough wetland and wetland buffer. Mitigation for this impact will consist of increasing evergreen tree species in the area and replacing invasive species with native vegetation where possible. The slope will be graded to a 2:1 (50 percent) maximum and planted with a SSB-typical planting. A SSB planting will also be used in the toe of slope setback area within the wetland and stream buffers, except under the Wye Creek crossing, where a SSBL planning will be used along the creek. A FW planting will be used outside of the guideway VCZ, and SSW planting will be used within the VCZ. There will also be infill planting just south of this area.

- **Steep slope area #22** (see Figure 9 in Appendix E): This steep slope area is located near the southwest corner of the wetland, along the west edge. The slope and toe of slope setback are not in the project construction area. The top of slope buffer is within a paved parking and access road area. Part of the retained fill approach to the aerial guideway along the south edge of the wetland will be in the slope #22 top of slope buffer. There is no existing vegetation in the top of slope buffer area. The project will construct underground utilities and replace pavement. There will not be a significant impact to habitat associated with species of local importance.
- **Steep slope area #23** (see figure 9 in Appendix E): This steep slope area is located along the south side of Kelsey West Tributary Pond wetland. The aerial guideway will cross the slope with one column and foundation in the slope area. The toe of slope setback is in the Kelsey West Tributary Pond wetland. The top of slope buffer is mainly on an existing paved surface. Some trees within the wetland VCZ will be removed, but most are willow species that can be replaced with large shrub species that will provide an equivalent habitat diversity. The portions of the wetland buffer that will be in the VCZ under the aerial guideway will be planted with SSB plants. The wetland in the VCZ will have infill planting, which will also mitigate for the permanent impacts from the column and tree removal. There will not be a significant impact to habitat associated with species of local importance.
- **Steep slope area #24** (see Figure 9 in Appendix E): This steep slope area is located near the southeast corner of the Kelsey West Tributary Pond wetland and east of the West Tributary to Kelsey Creek stream. Most of the top of slope buffer is under building structure and pavement. The toe of slope setback is on wetland and stream buffer and pavement. The slope is within an area infested with Himalayan blackberry. Impacts in this area are due to construction access to build the elevated guideway and its associated storm drain system. With the exception of the column within this area, all planting areas will be restored with native plants. Also, stream buffer improvements will assist in boosting habitat diversity within the open channel. There will not be a significant impact to habitat associated with species of local importance.

3.2 Compensatory Mitigation

3.2.1 Sweyolocken Site

The Sweyolocken site is on City-owned property in Section 08, Township 24 North, Range 5 East (Figure 3-1). The site is within the 350+-acre Mercer Slough wetland complex. The land is currently zoned as R-1 (Single-Family Residential Estate), and the current land use is agricultural for blueberry farming. Field investigations revealed that most or all of this area is within the existing jurisdictional wetland boundary. Efforts to alter the hydrology by draining the agricultural area are evident from two large ditches running perpendicular to Mercer Slough. Until recently, water has been pumped from the ditches to the slough, affecting the wetland hydrology. The existing ditches are still having a negative impact on the ability of the area to detain and filter flows of stormwater. Filling in these ditches will improve the hydrologic function immediately adjacent to the ditches, providing rehabilitation of that

wetland area. It is currently estimated that hydrology associated with 1.50 acres of wetland would be rehabilitated by these actions. The site was selected for several reasons, including the following:

- It is within a large, protected wetland complex – dominated by native wetland vegetation
- It is within the same wetland, sub-basin, and basin as some of the wetland impacts
- It has existing wetland soils
- The elevation, topography, and hydrology lend themselves to successful wetland rehabilitation and enhancement
- It is in an area that is heavily used by many species, including species that prefer wetland habitats
- It is located within and adjacent to a City parkland and open space

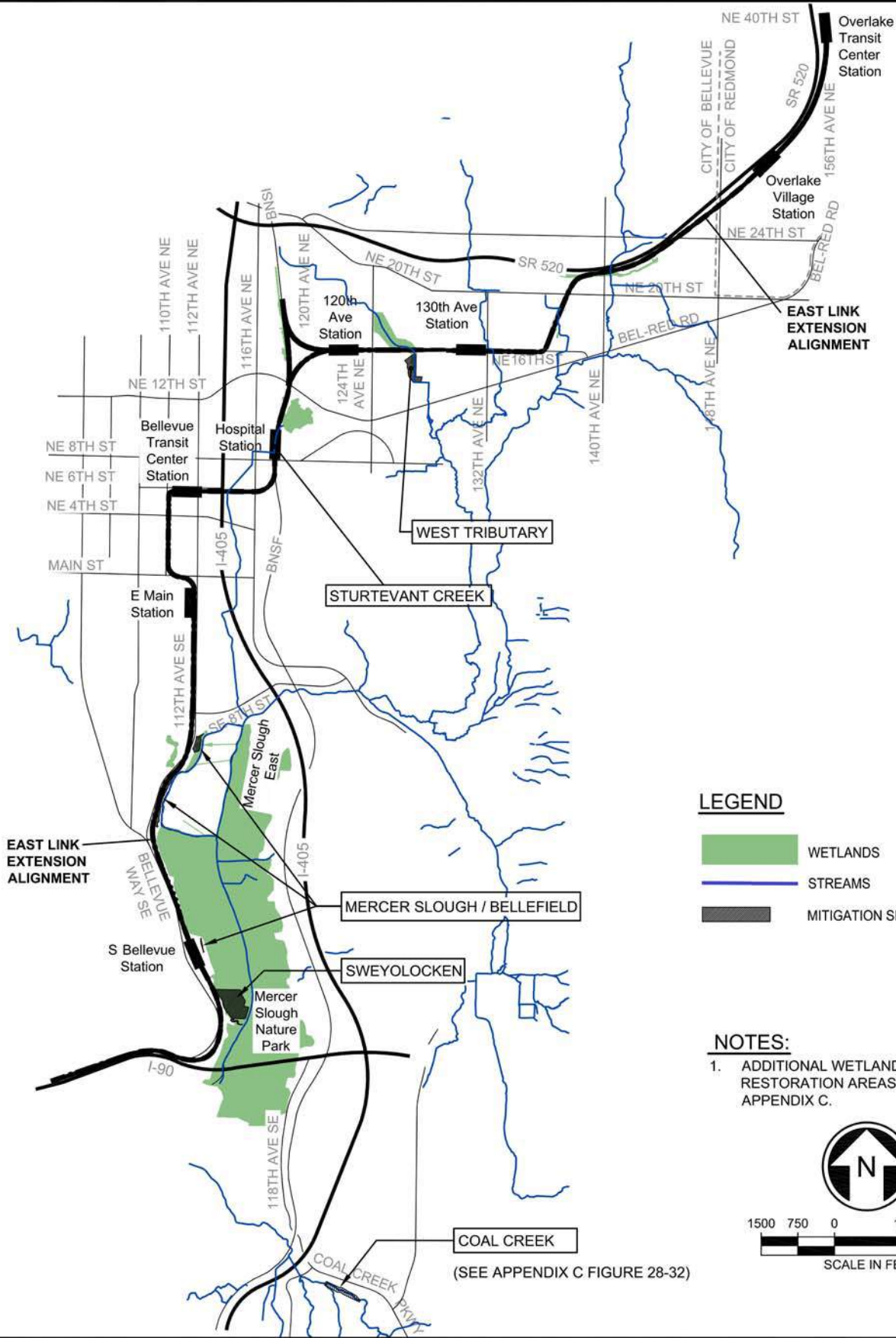

LEGEND

- WETLANDS
- STREAMS
- MITIGATION SITES

NOTES:

1. ADDITIONAL WETLAND AND BUFFER RESTORATION AREAS CAN BE SEEN IN APPENDIX C.

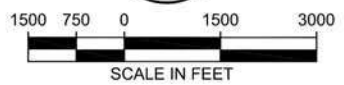

(SEE APPENDIX C FIGURE 28-32)

05/19/15 | 4:00 PM | J.LOGAN
J:\55229\CADD\DS001\DRAWINGS\ARCH\CRITICAL AREAS REPORT\REPORT FIGURES\CAR3-1.DWG



EAST LINK EXTENSION
SOUTH BELLEVUE TO OVERLAKE TRANSIT CENTER
 FIGURE 3-1
 PROPOSED
 MITIGATION SITES

3.2.1.1. Existing Conditions of the Site

The Sweyolocken site is part of the Mercer Slough Wetland complex, which is at the mouth of the Mercer Slough sub-basin of WRIA 8. Historically, the site was submerged, but when Lake Washington was lowered in 1916, the area began to form into a several-hundred-acre freshwater wetland complex. Portions of the wetland have been used to produce berries (primarily blueberries), although most of the complex is now in restoration or in relatively natural condition. The hydrology of the site is primarily controlled by Lake Washington, but is also influenced by occasional high flows in Mercer Slough. The elevation of Lake Washington is controlled at the Chittenden Locks in Ballard. Typical water surface elevations are about 2 feet higher at the maximum in late spring or early summer than at their minimum in late fall or early winter. Surface water flows from Mercer Slough, direct precipitation, and runoff also affect the site hydrology. Hydrology within the mitigation site is also affected by drainage ditches that run from the west to the east and drain to Mercer Slough. Evidence (e.g., air photos, site infrastructure) suggests that these ditches were pumped to Mercer Slough during the summer months (when lake levels are high), at least.

The site soils are mapped as Seattle muck in the north and Snohomish silt loam to the south. Field investigation of soils indicates that the entire site is underlain by peat or stratified peat and muck below a depth of about 12 to 14 inches. Above the peat the soils are very dark and very poorly drained, and range in texture from silt loam to muck. Soils ranged from black (10YR 2/1), to very dark brown (10YR 2/2), to very dark gray (10YR 3/1), to dark gray (10YR 4/1). Wetland soil textures in the upper horizons ranged from silt, to silt loam, to clay loam, to sandy loam.

Soils were typically saturated to the surface in the soil data pits, except near the ditches. Hydrology was also affected by microtopography, but saturation was always encountered at depth of 16 inches or less. The water table was typically encountered at a depth of less than 12 inches, but ranged from the surface to a depth greater than 18 inches, where the effect of the drainage ditches was most pronounced.

Vegetation communities on the site indicate the effects of both agricultural management and limited ecological restoration efforts. The majority of the mitigation area is planted in rows of mature domesticated blueberry (*Vaccinium* sp.). Between the rows a variety of wetland grasses are present, but reed canarygrass dominates. Near the ditches, the Himalayan blackberry is becoming established. The north portion of the site is dominated by spirea and red-osier dogwood. A dense, approximately 0.25-acre patch of Pacific willow that may be the result of a restoration effort is located between the two ditches. A grove of paper birch planted in rows is just southeast of the Pacific willow on the opposite side of the ditch. The southern border of the site and much of eastern edge near the slough are dominated by large black cottonwood, in some cases with an understory of Himalayan blackberry. Additional plant species common at the site include red alder, salmonberry, cattail, soft rush, small bedstraw, and spike rush (*Eleocharis palustris*).

The Mercer Slough Wetland complex supports a wide variety of fauna. One hundred and four bird species and 24 mammals have been observed in the Mercer Slough area (Carrsaco et al. 2013). Seventy

species have been observed in the shrub and forested swamp areas and the riparian edge, due to the structural complexity of the vegetation. By comparison, only 37 species were observed in the agricultural lands. Passerine birds enjoy habitats like shrub swamps adjacent to open water. The highest diversity of birds occurs in the late spring. Common year round birds are sparrows, robins, chickadees, bushtits, kinglets, crows, jays, woodpeckers, and wrens. American bitterns and green backed herons forage and breed in the Mercer Slough. Great blue herons have been known to nest in the Mercer Slough (Carrsaco et al. 2013).

3.2.1.2. Description of Mitigation Design

The proposed wetland mitigation will compensate for wetland impacts in the southern areas of the Project, as well as steep slopes associated with habitat of species of local importance (steep slope area numbers 3, 6, 8, 12, 14, and 15). The rehabilitation of wetland hydrology and vegetation enhancement will create diverse, complex habitat structure to support a much greater diversity of species than are supported by the site's current agricultural use. This variety of species will provide diversity to increase the opportunity to meet specific habitat requirements of a variety of fauna. The Swaylocken site will include habitat features such as standing snags, downed large woody material, brush, and boulder piles. Evidence of wildlife use will be documented in the monitoring program. Topographic adjustments will be made to rehabilitate hydrology and create niches for forested, shrub-scrub, and emergent wetland types. Small topographic depressions will be created that not only support obligate emergent vegetation, but that will also increase the hydrologic and water quality function of the wetland. The primary site constraint is access, and beyond a few existing roads, care will be taken to avoid soil compaction during construction using wetland soil mats or plates. Existing roads, and all associated culverts and other drainage infrastructure encountered will be decommissioned, and associated soils will be decompacted and amended as needed. Specific functions provided by the mitigation are described below.

3.2.1.3. Proposed Mitigation Site Hydrology

Site hydrology will continue to be controlled by Lake Washington and Mercer Slough water surface elevations. Ditches across the site will be filled to remove the influence of these structures on the adjoining areas. It is anticipated that this will effectively raise water surface (or groundwater) elevation in the winter and spring when the ditches are most effective (due to low lake levels). In addition, small, shallow depressions will be created by excavating soil to create a mound and pool feature. These "microtopographic features" increase habitat diversity and detain surface water flows during major rain events and rain on snow events. Microtopography mimics tip-up mounds from forested systems and allows facultative plant species to establish on the hummock and obligate species to establish in the depressions. The increase in woody vegetation and dense vegetation in general will increase sediment trapping and other water quality functions of the wetland. The overall grading affect will work with the existing microtopography to create areas of standing water that will create an opportunity to trap sediment and nutrients before it reaches the slough and lake. These features will dry in the summer

months, but wetland hydrology will be maintained by the high lake levels. The lake is typically at or near the high elevation of 18.67 feet (National Geodetic Vertical Datum 1988 [NGVD88]) from May to July.

3.2.1.4. Mitigation Site Soils and Grading

Existing site soils are described above. Minor grading will be required on site to fill ditches and any associated drain tiles, remove culverts, and create microtopographic features. Overall, a minimal amount of soil is anticipated to be imported. Soil amendments and woody mulch will be used in some areas to suppress invasive species and provide decompaction of existing soils over time. Site grading will have three major components: lowering grades within the reed canarygrass field in the north, filling existing ditches to match existing grades, and creating microhabitats throughout the site to establish forested, shrub, and emergent vegetation.

Areas north of the agricultural ditches that have a robust reed canarygrass community will be lowered in elevation to maintain inundation past the germination period for reed canarygrass (April to May) and to sustain obligate wetland species. The site is currently relatively flat, with an extremely low slope in the direction of Mercer Slough. The ditches (and associated pumps) are the only known drainage infrastructure on the site, and any drain tile or other subgrade drainage encountered during the construction will be removed or effectively decommissioned in place. All the ditches will be filled with imported material and any culvert under internal access roads will be removed. Habitat and species diversity will be increased by excavating tip up mounds and creating small ponded areas surrounded by slightly higher areas. This will create ponded depressions for obligate species where inundation well into the growing season will help to limit facultative invasive species such as reed canarygrass. On the mounds and other raised areas, woody vegetation will be planted to create a dense overstory that will help to shade out invasive species. This variety of species will provide diversity to increase the opportunity to meet specific habitat requirements of a variety of fauna.

3.2.1.5. Mitigation Site Planting

Prior to planting, the contractor will canvas the site for invasive species. Species-specific approaches will be developed to control invasive species. These may include mechanical removal, excavation of topsoil (and hauling off-site), mowing, mulching, and other methods. Most of the blueberry shrubs will be removed, except for a few small groupings. The few remaining shrubs will provide vertical diversity, immediate food sources for local fauna, and shade for newly installed plants immediately surrounding the shrubs. It is anticipated blueberry shrubs will be removed by mechanical means but approved herbicides may also be used. Methods such as low pressure vehicles and crane mats will be employed during mechanical removal. This will be done to minimize soil compaction and preserve existing desirable native emergent plant species. Native trees, shrubs, and emergent plant species will then be planted throughout the site. Large woody debris and snags will also be installed. Some of the wood from the blueberry shrubs will be placed throughout the site in piles for songbird and mammal habitat.

Plant species selection will be based on developing a number of habitat types with high degree of interspersed and edge length. This arrangement will help to increase habitat diversity and complexity

within the larger wetland. Buffer area will also be treated by removing invasive species, including blackberry and ivy, and under planting existing trees with native shrubs.

3.2.2 Sturtevant Creek

Conflicts with the Project alignment require that 3,443 sf of the OHWM of Sturtevant Creek be permanently filled and realigned to a new channel. This work will occur in Section 28, Township 25 North, Range 5 East, just north of NE 8th Street, east of a Whole Foods grocery store, and southwest of Lake Bellevue (Appendix C, Figures 16 to 21; Appendix D, Figures 8 and 9). The stream will be relocated to the west, directly adjacent to its current location. The new stream channel will match current flow and volume capacity, while providing improved habitat. The new channel will be slightly longer because it will be shifted approximately 13 feet west of its current location. The existing overflow structure at the south end of the stream will also be relocated to the west, which will reduce the existing piped stream length by approximately 13 feet. The substrate of the channel will be cobble that is sized for the flow regime, and the slopes will be vegetated to prevent erosion.

3.2.2.1. Existing Conditions of the Site

Sturtevant Creek flows out of Lake Bellevue wetland. The area of impact is downstream of the lake outlet. The stream in this area is confined to a straightened trapezoidal channel that runs parallel and east of the BNSF tracks. The channel bed is fairly uniform and consists of fine grain sediment with some vegetation. At the downstream end the vegetation is thicker and is dominated by reed canarygrass. The stream enters a manhole with a drop where it is combined with stormwater from the south. The flow is directed west, under the tracks in a short culvert. A very short (about 15-foot) daylighted section of stream exists to the west of the tracks before another culvert directs the flow south under NE 8th Street. The new channel alignment will remain on the BNSF ROW, which is now controlled by Sound Transit. A zone to accommodate future heavy rail or trail use is located to the west of the new channel and guideway alignments. This zone, or development envelope, is 18 feet wide and 22.5 feet tall and can be seen in Figure 19 of Appendix B. No additional space is available in this heavily developed area to increase the meander zone of the creek or decrease the slope of the banks.

The site was selected to minimize the disturbance to the hydrology and conveyance of the system and to allow for the continued use of existing downstream conveyances. Historically, the site was used as a rail corridor and is zoned as Commercial (BR-CG).

There are two existing wetlands on the site (South Lake and Central Lake) that will be impacted during construction of the elevated guideway, and restoration efforts are anticipated to provide a vegetative community with smaller plant species. The mitigation for this vegetation conversion impact will occur at another site. South Lake Wetland and Central Lake Wetland are both considered Category III wetlands using City criteria.

Flows in the reach are controlled at the outlet of Lake Bellevue. No actions related to this Project will occur at the outlet, and flows and lake levels will not be affected. Currently, the outlet of the lake is managed by property owners to prevent vegetation and debris from reducing the flow out of the lake

and creating flood hazards to the private development on and adjacent to the lake. The discharge downstream to the realigned reach is not changed, but the stream slope, bank roughness, and capacity will be engineered to minimize velocity and scour while maintaining the same or greater conveyance capacity of the existing channel.

Site soils are mapped as Alderwood, gravelly, sandy loam; however, there is a great deal of railway ballast and fill prisms on the site associated with the railroad tracks and adjacent development. As a result, angular rock, gravel, and cobble fill material frequently overlays or is mixed with the native soils.

Vegetation is extremely limited, and most of the site is bare gravel or pavement. Riparian vegetation is limited to herbaceous weeds on the channel banks, with red alder, Himalayan blackberry, Scot's broom, and other perennial weeds and grasses in the adjacent jurisdictional buffer. Other areas of the buffer are paved or part of the railway bed and track. There is no known fish use in the reach and little habitat suitable for wildlife.

3.2.2.2. Description of Mitigation Design

The mitigation design will essentially mimic the current conditions with the following exceptions;

- The new channel will be slightly longer and aligned farther to the west
- The new channel will have a rounded cobble substrate (existing channel is sand and silt)
- The new channel and the nearby South Lake and Central Lake wetlands will have a native scrub-shrub buffer that will be increased by 0.17 acre from its current conditions

3.2.2.3. Mitigation Site Hydrology

The hydrology of the new channel will be essentially consistent with the existing channel. The hydrology is controlled at the outlet of Lake Bellevue and will not be impacted by the Project or the mitigation.

The new channel has a similar capacity and slope as the existing channel.

3.2.2.4. Mitigation Site Soils

All soils, including topsoil, amendments, and stream bed materials, will be imported. Railway ballast and other unsuitable material will be removed from the mitigation area. These areas will be converted into new buffer for the stream and nearby wetlands to the north.

3.2.2.5. Mitigation Site Planting

The site will be planted with a native scrub-shrub community. The use of larger species (trees) would create a long-term hazard and conflict with the rail alignment. Native species will be selected based on hydrologic conditions where planting is to occur. One community will be used in wetter locations and will include woody and herbaceous vegetation, including red-osier dogwood and spirea. Vegetation installed along the banks of the stream channel will be chosen to not interfere with stream flow volumes. A second community for upland buffer areas may include thimbleberry, snowberry, and Oregon grape.

3.2.3 West Tributary

This site is made up of three parcels along the West Tributary to Kelsey Creek west of 124th Avenue NE and just south of the ponded wetland (Kelsey West Tributary Pond Wetland). The site is located in Section 28, Township 25 North, Range 5 East, just north of Bel-Red Road (Appendix C, Figures 23 and 24; Appendix D, Figures 10 and 11). Mitigation of permanent impacts to streams and wetlands will occur on this site, and will be accomplished by removing pavement and compacted fill on approximately 1.5 acres of the site, adding meanders to the existing open stream channel, expanding the riparian wetland complex, and the establishing a native vegetation buffer. The existing stream reach is currently considered a fish-bearing perennial stream by the city of Bellevue, but has a limited population of resident fish due to impassable culverts downstream of this reach. The site will provide 0.55 acre of wetland creation and 4,685 sf of stream enhancement.

3.2.3.1. Existing Conditions of the Site

The site is located in the upper reaches of the Kelsey Creek sub-basin of the Mercer Slough watershed. The drainage into the site comes largely from stormwater run-off, but is also fed by groundwater seeps along the toe of the SR 520 embankments. The existing site consists of compacted gravel and asphalt parking lot to the west and south. The lot was previously used for parking trucks in conjunction with a warehouse currently located on the site. A commercial building is located on a portion of the eastern property line. The site is zoned commercial (BR-CR) and is owned by the City of Bellevue Parks and Community Services. Future plans for the site include park amenities to the west of the mitigation area.

To the north of the site is a large open water wetland complex (Kelsey Creek West Tributary Pond Wetland) that is controlled at the outlet by a weir structure. This weir structure is managed to control downstream flooding and is not currently fish passable. This wetland is dominated by red alder, reed canarygrass, Pacific willow, spirea, and cattail. Beaver are active in the system, and localized flooding is an issue that requires maintenance by the City. Other species using the site are primarily birds (both migratory and resident species), especially waterfowl.

The West Tributary to Kelsey Creek flows from the ponded wetland to the south through the proposed mitigation site. The stream runs in a rock-lined channel for about 200 feet along the northeast corner of the site. This stream reach has a vegetated buffer width of about 60 feet that is dominated by Himalayan blackberry. There is a small (0.04-acre) riparian wetland associated with both banks of the creek. Immediately to the east of the channel is a large commercial building. A small berm separates the creek and riparian wetland from the building.

Soils on site are mapped as Alderwood gravelly sandy loam, but are likely overlain by imported fill in paved and gravel areas. Field investigations conducted for the Project found that soils in the wetland are consistent in color and character from the surface to below 18 inches deep. The soils are a very dark grayish brown (10YR 3/1) silt loam with no redox features. The hydrology of the wetland is linked with the West Tributary to Kelsey Creek, and soils are commonly saturated or inundated to the surface. Site

hydrology is currently being investigated by monitoring shallow groundwater wells placed within the proposed mitigation and excavation area.

The dominant vegetation species within this wetland are Pacific willow, red-osier dogwood, bittersweet nightshade, reed canarygrass, soft rush, and Himalayan blackberry. Vegetation on the margins of the site and around the stream is dominated by Himalayan blackberry and other invasive vegetation.

A Phase 2 subsurface site assessment has been developed for the site (G-Logics 2009), and utilities have been located and surveyed.

Kelsey West Tributary Stream Wetland scores a moderate potential to improve water quality and provide opportunities to improve water quality (16 out of 32 possible maximum score). The wetland scores a moderate potential to reduce flooding and erosion and provides the opportunity to reduce flooding and erosion (18 out of 32 possible maximum score). The wetland scores a moderate potential and opportunity (16 out of 36 possible maximum score) to provide habitat functions. Overall, the total Ecology wetland functions score for Kelsey West Tributary Stream Wetland is 50 out of a possible 100.

3.2.3.2. Description of Mitigation Design

The proposed mitigation will compensate for wetland and stream impacts in the northern areas of the Project, as well as steep slopes associated with habitat of species of local importance (steep slope area numbers 22, 23, and 24). The goal of the mitigation design will be to remove about 10 feet of soil, to significantly expand the associated wetland. Adjacent areas will be planted with native species to provide a dense vegetated buffer. Slopes to the east will range from 5H:1V to 8H:1V to meet the grades at the existing property line. The design preserves the existing riparian wetland and provides 0.55 acre of created wetland on the west (right) bank of the stream. The design includes a depressional terrace adjacent to the channel to provide flood storage of high flows and off channel refuge to aquatic species. The design also includes a series of pools and riffles, upstream of the wetland in the existing channel. These will be stabilized in place using LWD and imported stream bed materials will be used to enhance habitat and improve upstream fish passage.

The mitigation design concepts in Appendix C (Figures 23 and 24) include a newly created 60-foot-wide average wetland buffer, which matches the buffer for a Category III wetland. The narrowest buffer areas are not less than 45 feet, which follows the BCC requirements to provide a buffer that is at least 75 percent of the required buffer for the newly created wetland. The site provides an excellent opportunity to improve the connection between the Kelsey West Tributary Pond Wetland with other stream and wetland habitats downstream, many of which are in restoration (Glendale Country Club, Kelsey Creek Farm, SE 8th Culvert, etc.) This project will not complete that connection, but will be a first phase that will compliment a future restoration to be led by the City to improve fish passage under Bel-Red Road.

3.2.3.3. Mitigation Site Hydrology

Once excavated, the proposed mitigation site is anticipated to remain saturated at the surface by groundwater and surface water connectivity with the creek. In addition, peak flows from the West

Tributary to Kelsey Creek will potentially enter the created wetland during large storm events at a regular recurrence. While base flows are relatively low (<2 cubic feet per second [cfs]) peak flows are much higher. The estimated 2-year recurrence flow (annual probability 50 percent) is 25 cfs (FEMA 2005).

3.2.3.4. Mitigation Site Soils and Grading

Mitigation site soils, amendments, and stream bed materials will be imported from an approved off-site location to ensure adequate fertility and composition. Boulders, snags, and LWD will also be imported (or obtained from the Project area as practicable) to create stream and wetland habitat complexity. LWD placed in the streambanks will provide habitat and potentially protect the channel against erosion of the banks during high flows. The created wetland will be configured to allow access to fish at high flows and provide a quiescent area for turbid water to settle and sediment and waterborne contaminants to be entrained by wetland vegetation. The site is designed to concentrate the habitat areas in a migratory corridor suitable for multiple species along the eastern boundary of the site. This will minimize the habitat impacts of future park development. Site grading will also create areas of ponded water from rainfall, site runoff, and after inundation by high flows. These areas are expected to stay inundated well into the growing season (May or June), and this inundation will help promote the establishment of dense, obligate vegetation and help control facultative invasive species—notably reed canarygrass. Some of the banks above the ponded areas are expected to be fed by groundwater seeps that will remain moist based on well data now being collected. This will allow the establishment of woody facultative species that provide shade and cover to aquatic areas.

3.2.3.5. Mitigation Site Planting

The mitigation design and site planting is shown in Appendix C (Figures 1 through 29) and D (Figures 1 through 13). The site was configured to improve the connectivity of existing high quality aquatic, wetland, and riparian habitats, while maintaining the potential for future park and trail improvements outside the jurisdictional wetland buffer. Any future use of the site will be required to comply with the CAO (BCC Chapter 20.25H), including buffer protection.

Plant species selection will only include native species and will focus on those that provide water quality and or specific habitat function. Emergent and scrub-shrub wetland species that are able to trap sediment and other pollutants include, but are not limited to bulrush, willow, hardhack, and slough sedge. Buffer species that provide forage and nesting habitat include, but are not limited to willow, red twig dogwood, hardhack, snowberry, thimbleberry, Douglas fir, and Sitka spruce.

3.2.4 Mercer Slough/Bellefield

This mitigation area will consist of the following: 1) invasive removal and infill planting of existing wetlands, 2) invasive species control in existing buffers, 3) revegetation of wetland buffer areas, and 4) restoring temporarily impacted wetlands and buffers. These areas are located along the east side of Bellevue Way SE and 112th Avenue SE. The newly created buffer areas are located between the relocated 112th Avenue SE and Mercer Slough. The existing areas are primarily dominated by mowed

lawn, nonnative blackberry, and patches of sparse trees. This makes the area an excellent candidate for enhancement activities.

Native vegetation will be planted to enhance the area between the future guideway, 112th Avenue SE and the west bank of West Mercer Slough. This includes the portions of the Bellefield South and Bellefield North wetlands to remain and be enhanced and the associated wetland buffers. This wetland and buffer enhancement and creation work will improve water quality, habitat cover, organic input, shade, and other stream and wetland buffer functions.

3.2.4.1. Existing Conditions of the Site

The site is currently comprised of City-owned ROW, areas within Mercer Slough Nature Park, and a privately held tract lot associated with the Bellefield Office Park (a tract lot is an undivided interest within a plat and is not considered a lot or building site for purposes of development or construction).

The areas are topographically perched several feet above Mercer Slough and lack wetland characteristics and wetland vegetation. The soils include a mix of imported soils, fill associated with the adjacent road, and excavated materials from the slough and landfill debris. Vegetation is dominated by mowed lawn and dense thickets of the invasive species Himalayan blackberry, with a few isolated patches of ornamental and native trees.

The Bellefield Office Park site was created by filling 130 acres of wetlands. This area contains the Bellefield South and Bellefield North wetlands. Both wetlands are Category II riverine-slope wetlands that will be impacted from unavoidable impacts related to Project construction. Dominant vegetation in these two wetlands includes Oregon ash, black cottonwood, red alder, Pacific willow, prickly currant (*Ribes lacustre*), Himalayan blackberry, lady fern (*Athyrium felix-femina*), and stinging nettle (*Urtica dioica*) This includes construction of the 112th Avenue SE and SE 15th Street intersection that accommodates the guideway undercrossing.

Site soils are mapped as Seattle muck in the slough and relic channels, and as Alderwood gravelly sandy loam, and Everett-Alderwood gravelly sandy loam in upland areas. However, this area has a history of development, excavation, and other ground disturbance activities, and evidence of fill material and other imported soil material is present in most of the upland areas.

The hydrology of the Bellefield South and Bellefield North wetlands is associated with Mercer Slough. However, the wetlands are located upslope of the slough, and the source of hydrology within the wetland is dominated by seeps and groundwater sources, as opposed to water from the slough extending above the OHWM into the wetlands. Additional hydrology from seeps along the slopes above the slough will also help support a diversity of riparian vegetation.

Soils in the two wetlands were identified as typically black (10YR 2/1) loam to below 18 inches deep. Charcoal and brick were observed in the soil profile, these may be an indication of past land use activities on site. Upland soils observed were significantly lighter in color (10YR 3/4 to 5/4, 10YR 2/2) and loamy, but often containing coarse organic material, charcoal or debris at depth. The charcoal and debris is consistent with known use of the site as a construction material dump in the 1960s.

Dominant vegetation species in the wetlands include Oregon ash and black cottonwood canopy, with stinging nettle, red twig dogwood, and Himalayan blackberry understory. The buffer is dominated by Himalayan blackberry, with some stinging nettle and red elderberry. Areas along the entrance to the Bellefield Office Park (SE 15th Street) are landscaped with turf and ornamental trees. There are some functions provided by the existing vegetation. Specifically, shade and organic input from trees and ground cover to prevent soil erosion. Himalayan blackberry provides food and nesting sites for some birds.

3.2.4.2. Description of Mitigation Design

The Project requires that the roadway at the 112th Avenue SE and SE 15th Street intersection be elevated to allow the light rail guideway to go under 112th Avenue SE. This will result in permanently filling 0.05 acre of the Bellefield South Wetland, 0.01 acre of the Bellevue North Wetland, and a total of 0.44 acre of buffer impact (0.20 to Bellefield South and 0.24 to Bellefield North). The buffers of these wetlands will also be permanently impacted by roadway construction. To the south, guideway and other Project-related construction will impact some areas of nonnative vegetation in buffers. The mitigation design will rely on controlling the existing Himalayan blackberry and establishing native wetland and riparian communities in the remaining wetland and buffer. The existing wetland vegetation has been heavily impacted by invasive species and sporadic mowing. Removing invasive plant species, invasive species maintenance during the monitoring period, and planting native wetland species in the wetland and wetland buffer will enhance the existing conditions by providing a more robust and diverse plant community. Willow and other flood tolerant species will be used near the water, while more drought tolerant pioneer and seral species will be planted in the remainder of the upland buffer.

Other buffer enhancement and creation areas are located to the south and east of the proposed South Bellevue Station/Park and Ride. The concept for the area to the south includes a conversion of open lawn areas into wetland buffer. Many of these areas are not considered buffers, so this would provide more regulated buffer for the Mercer Slough wetland. The east side of the proposed parking structure has a major infestation of English ivy that is growing on many of the native deciduous trees. The concept is to remove all invasive species and plant native species where appropriate.

3.2.4.3. Mitigation Site Hydrology

This buffer enhancement/creation site will remain upland. The connection of the wetlands to Mercer Slough will not be affected by the Project, so no impact to wetland hydrology of Mercer Slough is anticipated. Subsurface and surficial sheet flow that currently supports the wetland hydrology of the Bellefield South and Bellefield North wetlands will be maintained by routing flows through permeable fill under the new 112th Avenue SE roadway and redistributing that flow back into the wetland areas to remain.

3.2.4.4. Mitigation Site Soils

Site soils will be grubbed to remove roots from invasive plant species and other organic material. Soil amendments will be added, as necessary, and woody mulch will be used to control future colonization

by invasive species and to retain moisture in the soil. Wetland areas to remain and be enhanced will not be impacted, and their soils will not be disturbed unless it is necessary for invasive species removal and planting native wetland species. Care will be taken not to compact soils in wetland areas with temporary impacts to vegetation.

3.2.4.5. Mitigation Site Planting

The mitigation site will be planted in zones based on relative elevation above Mercer Slough and distance from the guideway. Within 4 vertical feet of the OHWM, willow and dogwood will be planted in the wetland buffer areas. Above that a forested community comprised of Douglas fir, big leaf Maple, red alder, and grand fir will be planted, with an understory of native shrubs such as Tall Oregon grape, thimbleberry, and red elderberry. In the wetland enhancement areas, tree species such as Oregon ash, Sitka spruce, Pacific willow, and western red cedar will be planted. Shrub species will include species such as red-osier dogwood, salmonberry, and twinberry. Lady fern will be planted as an emergent, understory species. Adjacent to the guideway, only shrubs will be planted to limit future conflicts with light rail operations. Temporary irrigation will be used as needed during plant establishment (typically 1 to 3 years).

3.2.5 Coal Creek

Piping the Unnamed Tributary to Kelsey Creek will require off-site stream mitigation. This project location was identified during environmental monitoring of macro-invertebrate assemblages and other metrics of stream health conducted by the City in 2013. The reach showed limited habitat complexity and unsorted substrate due to a relative lack of LWD. These conditions do not appear to support a full complement of benthic macro-invertebrate species common to healthy streams in the region. A recently constructed off-channel sediment pond upstream of the proposed mitigation site provides some protection from peak flows and excessive sediment deposition at the site. It is believed that in-stream wood placement would result in localized scour and substrate sorting to improve habitat diversity and provide improved rearing, holding, and migratory habitats for resident and anadromous fish species already present in the system. The site has potential for multiple species of salmon spawning. The existing functional status is compromised, and the potential for improvement is good. The site is owned by the City, who supports the project. Sound Transit would lead the design and construction of the project and would be responsible for funding construction monitoring and any necessary contingency actions related to the project. Construction of the project will occur within 1 year of impacts to the Unnamed Tributary to Kelsey Creek.

3.2.5.1. Existing Conditions of the Site

This reach of Coal Creek is from approximately river mile (RM) 0.6 to 0.7 and is just upstream of 119 Avenue SE. The Coal Creek Off-Line Sediment Pond was constructed at RM 1.3 by the City of Bellevue in 2010 to address high sediment loads associated with urban runoff that compromises fish habitat conditions. That project was implemented as part of a larger basin management program that has included the installation of off-line sediment ponds at two locations in the lower reach of Coal

Creek. Based on the Year 3 (2013) monitoring report for the project, the mitigation performance standards for the 2010 project are being met (ESA 2013).

The stream through the entire lower reach of Coal Creek above 119 Avenue SE has the potential to provide additional habitat for fish, despite currently meeting the mitigation performance standards. Earlier projects included recently planted riparian buffer vegetation, and installation of the off line sediment pond; however, the channel itself has been found to have poor diversity of benthic invertebrate species (Rhithron 2014). The benthic species assemblages encountered are indicative of poor habitat conditions in general, and taxa richness was lower than expected, which may indicate disturbed or monotonous in-stream habitats. It is expected that the relatively fine substrate, limited habitat complexity, and lack of pool-riffle sequence habitats in the reach also limit the suitable spawning habitat for coho and other species in the system (e.g., cutthroat, Chinook).

3.2.5.2. Description of Mitigation Design

The project will include installing LWD in the reach. LWD placements in the active channel are anticipated to provide localized scour, stimulating the creation of pool-riffle sequences that will provide improved habitat. Pools provide holding areas for adults moving upstream through the system, and rearing habitat for juveniles. Riffles provide spawning habitat for adults and favorable conditions for benthic invertebrates that are an important food source for juveniles. The design of this project will be based on the WDFW Stream Habitat Restoration Guidelines (Cramer 2012). This specifically applies to target wood loading within the mitigation site at or above the median for reference streams in the same size and bio-geographic class (Fox and Bolton 2007). The site is currently forested, with a mix of deciduous and coniferous species. Mitigation planting is anticipated to be minimal. Native plantings will be planted in areas that were disturbed as a result of construction and will match the species and spacing that were originally installed as part of the buffer mitigation.

An existing laydown and staging area is available adjacent to 119 Avenue SE that provides excellent access to the stream. Equipment access to the stream for LWD installation may require some localized vegetation removal, but it is believed that this can be limited to low growing shrubs, and that impacts to mature trees can be avoided. All access areas will be restored and re-vegetated to match previous conditions where feasible.

3.3 Wetland Mitigation Site Functional Lift Analysis

Three of the four proposed wetland mitigation Project sites (Sweyolocken, West Tributary, and Mercer Slough/Bellefield) were rated according to the most current Ecology guidance documents (Hruby 2004; Ecology 2008a). The ratings are based on the proposed design for these wetland systems (Appendix D). As described in Section 3.0, the Sweyolocken site is an existing wetland proposed for wetland enhancement and rehabilitation, the West Tributary site is proposed for wetland creation, stream enhancement, buffer creation, and enhancement, and the Mercer Slough/Bellefield site is proposed for wetland enhancement, buffer creation, and enhancement.

The expected classifications and ratings of the proposed Swayolocken, West Tributary, and Mercer Slough/Bellefield wetland mitigation sites are based on the design approach provided in Table 3-10. Expected water quality, hydrologic, and habitat functional values for the proposed mitigation sites are shown on Table 3-10 and described below in Table 3-11.

Table 3-10 Wetland Mitigation Sites Classifications and Ratings Based on the Design Approach

Wetland Mitigation Site	USFWS (Cowardin) Classification	Hydrogeomorphic Classification	State (Ecology) and Local (Bellevue) Rating
Swayolocken	Forested, Scrub-shrub, and Emergent	Riverine	II
West Tributary	Forested, Scrub-shrub, and Emergent	Riverine	II
Mercer Slough/Bellefield	Forested, and Scrub-shrub	Riverine, Slope	II

Table 3-11 Summary of Functions and Values for Proposed Wetland Mitigation Site Rating Scores

Wetland Mitigation Sites	Water Quality Functions Potential Score	Water Quality Functions Opportunity (Yes/No)	Hydrologic Functions Potential Score	Hydrologic Functions Opportunity (Yes/No)	Habitat Functions Potential Score	Habitat Functions Opportunity Score	Total Functions Score
Riverine Maximum Scores	16	No = 1 Yes = 2	16	No = 1 Yes = 2	18	18	100
Sweyolocken	10	Yes	13	No	13	10	56
West Tributary	10	Yes	13	Yes	13	10	69
Mercer Slough/Bellefield	10	Yes	8	Yes	11	8	55

3.3.1 Water Quality Functions

All three wetland mitigation sites are designed to score a moderate potential to improve water quality due to surface depressions within the riverine wetlands that can trap sediments during a flooding event and the characteristic of vegetation within the wetlands to trap sediments and pollutants. The amount of expected area within the Sweyolocken and West Tributary wetland mitigation sites for seasonal ponding or inundation also contributes to a moderate score. Mitigation activities at the Mercer Slough/Bellefield mitigation site are limited to enhancement, so wetland creation activities, such as grading to create depressions, are not a component of the enhancement elements.

All three wetland mitigation sites are expected to provide opportunities to improve water quality due to their location near roads and/or other developed areas. Additionally, removing agriculture activities at the blueberry farm in the Sweyolocken mitigation site will also improve water quality.

3.3.1.1. Hydrologic Functions

Both the Sweyolocken and West Tributary wetland mitigation sites are designed to have high scores for the potential to reduce flooding and erosion. The expected high scores for potential hydrologic functions are due to characteristics such as overbank storage capability and characteristics of the vegetation to slow down water velocities. The Mercer Slough/Bellefield mitigation site has a moderate score for the potential to reduce flooding and erosion due to the characteristics of the vegetation to slow down water velocities. Enhancement design features do not include modifying the overbank storage capabilities of the Bellefield South and Bellefield North wetlands.

The West Tributary Wetland and Mercer Slough/Bellefield mitigation sites provide the opportunity to reduce flooding and erosion because they drain to streams that flow downstream to areas that can be damaged by flooding. The Sweyolocken mitigation site does not provide opportunity to reduce flooding because it is located downstream in the watershed and associated with Lake Washington, which has controlled water levels. The Mercer Slough Wetland, which is located near the Sweyolocken mitigation site, was also scored as not providing the opportunity to reduce downstream flooding and erosion for these same reasons. The Bellefield South and Bellefield North wetlands are identified as providing the opportunity to reduce flooding and erosion because they are located upstream of the Bellefield Office Park.

3.3.1.2. Habitat Functions

Both the Sweyolocken and West Tributary wetland mitigation sites are designed to have a high potential score to provide habitat. The high scores for potential habitat functions are due to the vegetative structure having several Cowardin vegetation classes, the presence of several water regimes or hydroperiods, plant richness (more than 19 native species), and the presence of special habitat features, such as standing snags, downed woody debris, and few invasive plants. These two wetland mitigation sites will not contain mature forested vegetation classes during the early years, as planted trees become established. Both these wetland mitigation sites are designed to be planted with vegetation to develop forested, scrub-shrub, and emergent Cowardin vegetation classes once the vegetation matures. The

Mercer Slough/Bellefield mitigation site has a moderate potential score to provide habitat, missing a high potential score by only 2 points. Portions of the Bellefield South and Bellefield North wetlands currently contain many of the habitat characteristics described above for the Sweyolocken and West Tributary wetland mitigation sites, and the proposed wetland enhancement will increase these habitat functions. The Mercer Slough/Bellefield mitigation site does not have a high potential score to provide habitat because the proposed enhancement does not include modifications, such as creating additional hydroperiods or increasing wetland habitat along the shoreline of the Mercer Slough. All three wetland mitigation sites are expected to score a moderate potential opportunity to provide habitat for many species. The moderate score for habitat opportunity is due to the characteristics of the wetland buffers (developed versus undisturbed conditions), the overall quality of habitat conditions near or adjacent to the wetlands, and the connections to other wetland habitats. Several of these features depend on the condition outside of the mitigation sites and cannot be controlled as part of the mitigation design.

3.3.2 Comparison between Functions and Values of Disturbed Wetlands and Wetland Mitigation Sites

Ecology has produced the focus sheet *Using the Wetland Rating System in Compensatory Mitigation* (Ecology 2008b) as a guide to estimate changes in functions that can occur from impacts and compensatory mitigation. The methodology includes a qualitative comparison between individual groups of functions, based on the rating of function scores as low, moderate, or high (Tables 3-3 and 3-4), and calculating statistical variability in the function scores between the disturbed wetlands and the compensatory mitigation. The overall functions score has to increase by more than one-third to be considered a lift in functions. A difference of less than one-third is not considered statistically significant. The following assessment comparing functions of the ten disturbed wetlands and the three wetland mitigation sites was prepared per this Ecology methodology (Ecology 2008b). For this analysis, of the eleven wetlands that will be permanently disturbed, four have been allocated to the Sweyolocken wetland mitigation site, and six have been allocated to the West Tributary wetland mitigation site, based on the geographic locations of the wetlands and wetland mitigation sites within the Project area. For the Bellefield South and Bellefield North wetlands, permanent impacts to these wetlands are being mitigated at the Sweyolocken wetland mitigation site. Wetland enhancement mitigation will occur at the Mercer Slough/Bellefield mitigation site. The qualitative comparison of functions and the statistical variability in the functions scores between the wetlands permanently disturbed and the mitigation site is provided in Table 3-12 for the Sweyolocken site, and Table 3-13 for the West Tributary Wetland site. The qualitative comparison of the Bellefield South and Bellefield North wetlands and the wetland enhancement mitigation at the Mercer Slough/Bellefield mitigation site is provided in Table 3-14.

Table 3-12 Summary of Wetland Rating Scores and Sweyolocken Mitigation Site Functional Lift

	Improving Water Quality		Hydrologic Functions		Habitat Functions		Total Rating Score
	Potential (Score)	Opportunity (Yes/No)	Potential (Score)	Opportunity (Yes/No)	Potential (Score)	Opportunity (Score)	
Mercer Slough Wetland							
Existing Wetland Rating	Moderate (10)	Yes	Moderate (10)	No	High (17)	Moderate (10)	57
Sweyolocken Mitigation Site Rating	Moderate (10)	Yes	High (13)	No	High (13)	Moderate (10)	56
Change	No Change	No Change	Moderate to High	No Change	No Change	No Change	-1 (-2%) Not Significant¹
Bellefield South Wetland							
Existing Wetland Rating	Moderate (10)	Yes	Moderate (8)	Yes	Moderate (10)	Moderate (8)	54
Sweyolocken Mitigation Site Rating	Moderate (10)	Yes	High (13)	No	High (13)	Moderate (10)	56
Change	No Change	No Change	Moderate to High	Change from Yes to No	Moderate to High	No Change	2 (4%) Not Significant¹
Bellefield North Wetland							
Existing Wetland Rating	Moderate (10)	Yes	Moderate (8)	Yes	Moderate (9)	Moderate (8)	53
Sweyolocken Mitigation Site Rating	Moderate (10)	Yes	High (13)	No	High (13)	Moderate (10)	56
Change	No Change	No Change	Moderate to High	Change from Yes to No	Moderate to High	No Change	3 (6%) Not Significant¹
8th Street Wetland							
Existing Wetland Rating	Low (2)	Yes	High (12)	Yes	Low (6)	Low (5)	41
Sweyolocken Mitigation Site Rating	Moderate (10)	Yes	High (13)	No	High (13)	Moderate (10)	56

	Improving Water Quality		Hydrologic Functions		Habitat Functions		Total Rating Score
	Potential (Score)	Opportunity (Yes/No)	Potential (Score)	Opportunity (Yes/No)	Potential (Score)	Opportunity (Score)	
Change	Low to Moderate	No Change	No Change	Change from Yes to No	Low to High	Low to Moderate	15 (37%) Significant¹

Notes:

Source: Ecology 2008b

1 Significant is defined as an increase of the total score by more than one third.

Table 3-13 Summary of Wetland Rating Scores and West Tributary Mitigation Site Functional Lift

	Improving Water Quality		Hydrologic Functions		Habitat Functions		Total Rating Score
	Potential (Score)	Opportunity (Yes/No)	Potential (Score)	Opportunity (Yes/No)	Potential (Score)	Opportunity (Score)	
South Lake Wetland							
Existing Wetland Rating	Moderate (7)	Yes	Moderate (8)	Yes	Moderate (8)	Low (5)	43
West Tributary Mitigation Site Rating	Moderate (10)	Yes	High (13)	Yes	High (13)	Moderate (10)	69
Change	No Change	No Change	Moderate to High	No Change	Moderate to High	Low to Moderate	26 (60%) Significant¹
Central Lake Wetland							
Existing Wetland Rating	Low (4)	Yes	Moderate (10)	Yes	Moderate (7)	Low (4)	41
West Tributary Mitigation Site Rating	Moderate (10)	Yes	High (13)	Yes	High (13)	Moderate (10)	69
Change	Low to Moderate	No Change	Moderate to High	No Change	Moderate to High	Low to Moderate	26 (68%) Significant¹
North Lake Wetland							
Existing Wetland Rating	Low (4)	Yes	Low (4)	Yes	Low (6)	Low (4)	22
West Tributary Mitigation Site Rating	Moderate (10)	Yes	High (13)	Yes	High (13)	Moderate (10)	69
Change	Low to Moderate	No Change	Low to High	No Change	Low to High	Low to Moderate	47 (214%) Significant¹

	Improving Water Quality		Hydrologic Functions		Habitat Functions		Total Rating Score
	Potential (Score)	Opportunity (Yes/No)	Potential (Score)	Opportunity (Yes/No)	Potential (Score)	Opportunity (Score)	
BNSF East Wetland							
Existing Wetland Rating	Moderate (7)	Yes	Moderate (8)	Yes	Low (3)	Low (4)	37
West Tributary Mitigation Site Rating	Moderate (10)	Yes	High (13)	Yes	High (13)	Moderate (10)	69
Change	No Change	No Change	Moderate to High	No Change	Low to High	Low to Moderate	32 (86%) Significant¹
West Tributary Pond Wetland							
Existing Wetland Rating	High (11)	Yes	High (12)	Yes	Moderate (9)	Moderate (8)	63
West Tributary Mitigation Site Rating	Moderate (10)	Yes	High (13)	Yes	High (13)	Moderate (10)	69
Change	High to Moderate	No Change	No Change	No Change	Moderate to High	No Change	6 (10%) Not Significant¹
SR 520 West Wetland							
Existing Wetland Rating	Moderate (9)	Yes	Moderate (8)	Yes	Moderate (9)	Low (5)	48
West Tributary Mitigation Site Rating	Moderate (10)	Yes	High (13)	Yes	High (13)	Moderate (10)	69
Change	No Change	No Change	Moderate to High	No Change	Moderate to High	Low to Moderate	21 (44%) Significant¹

Notes:

Source: Ecology 2008b

1 Significant is defined as an increase of the total score by more than one third.

Table 3-14 Summary of Wetland Rating Scores and Mercer Slough/Bellefield Mitigation Site Functional Lift

	Improving Water Quality		Hydrologic Functions		Habitat Functions		Total Rating Score
	Potential (Score)	Opportunity (Yes/No)	Potential (Score)	Opportunity (Yes/No)	Potential (Score)	Opportunity (Score)	
Bellefield South Wetland							
Existing Wetland Rating	Moderate (10)	Yes	Moderate (8)	Yes	Moderate (10)	Moderate (8)	54
Mercer Slough/Bellefield Mitigation Site Rating	Moderate (10)	Yes	Moderate (8)	Yes	Moderate (11)	Moderate (8)	55
Change	No Change	No Change	No Change	No Change	No Change	No Change	1 (4%) Not Significant¹
Bellefield North Wetland							
Existing Wetland Rating	Moderate (10)	Yes	Moderate (8)	Yes	Moderate (9)	Moderate (8)	53
Mercer Slough/Bellefield Mitigation Site Rating	Moderate (10)	Yes	Moderate (8)	Yes	Moderate (11)	Moderate (8)	55
Change	No Change	No Change	No Change	No Change	No Change	No Change	2 (6%) Not Significant¹

Notes:

Source: Ecology 2008b

1 Significant is defined as an increase of the total score by more than one third.

The results of the qualitative comparison of functions between the wetlands and the wetland mitigation sites show some variation in the function ratings. As shown on Tables 3-12, 3-13, and 3-14, the Sweyolocken, West Tributary, and Mercer Slough/Bellefield wetland mitigation sites have one difference in their expected functional rating score based on the mitigation design. As described previously, the Sweyolocken mitigation site does not provide the opportunity to reduce flooding and erosion to downstream areas that can be damaged by flooding.

Because all eleven wetlands and the three wetland mitigation sites provide the opportunity to improve water quality, there is no change in the water quality opportunity between the wetlands and the mitigation sites. In addition to wetland mitigation, the Project will include several upgrades to on-site stormwater management facilities as a key component of the Project that will provide significant additional on-site mitigation of water quality.

The results of the qualitative comparison of functions between six of the eleven wetlands and the associated wetland mitigation sites show no change in function rating for potential to improve water quality. Three of the wetlands show a change in function rating from low to moderate for potential to improve water quality. One wetland, Kelsey Creek West Tributary Pond, shows a change in function rating from high to moderate for the potential to improve water quality because the high quality water quality functions of the presence of organic soils cannot be replicated at a created wetland mitigation site during the initial wetland mitigation creation. However, the wetland impact area for the wetland is very small, 0.01 acre, and on the border of the wetland system, so the overall high quality water quality functions of the existing wetland will not decrease as a result of the proposed disturbance.

Two wetlands, Kelsey Creek West Tributary Pond and 8th Street, show no change in function rating for potential to reduce flooding and erosion. Seven of the eleven wetlands show a change in function from moderate to high, and one wetland shows a change in function rating from low to high. The Bellefield South and Bellefield North wetlands show a change in function from moderate to high at the Sweyolocken mitigation site, and no change in function at the Mercer Slough/Bellefield mitigation site, because the enhancement activities do not include creating additional depressions within the existing wetlands.

The Sweyolocken wetland mitigation site does not provide the opportunity to reduce flooding and erosion, while the West Tributary and Mercer Slough/Bellefield sites do provide the opportunity. As a result, of the four wetlands allocated to the Sweyolocken mitigation site, one wetland, the Mercer Slough Wetland, has no change in this function, while the other three wetlands show a change from providing the opportunity to provide this function to not providing the opportunity. The reason for this change is that those impacts are being mitigated for at the Sweyolocken and the only area downstream of the Sweyolocken site is Lake Washington. Lake Washington is not susceptible to flooding due to its size and controls at the Hiram M. Chittenden Locks (Ballard Locks). For the West Tributary mitigation site, there is no change in the hydrologic opportunity between the remaining seven wetlands and the West Tributary mitigation site. In addition to wetland mitigation, the Project will include several

upgrades to on-site stormwater management facilities. This is a key component of the Project that will provide significant additional on-site mitigation of stormwater flow control functions.

Mercer Slough shows no change for potential to provide habitat. Three of the eleven wetlands show a change in function rating from low to high and six of the wetlands show a change in function rating from moderate to high for the potential to provide habitat. The Bellefield South and Bellefield North wetlands show a change in function from moderate to high at the Sweyolocken mitigation site. At the Mercer Slough/Bellefield mitigation site, the Bellefield South score for potential to provide habitat increases by 2 points, and the Bellefield North increases by 3 points. These point increases are below the threshold to increase the function from moderate to high by 1 point.

Finally, four of the eleven wetlands show no change for opportunity to provide habitat, and six wetlands show a change in function rating from low to moderate. The Bellefield South and Bellefield North wetlands show no change in function at the Sweyolocken mitigation site and at the Mercer Slough/Bellefield mitigation site.

Six of the eleven wetlands meet the statistically significant criteria of a lift in functions (an increase by more than one-third of the total score) between the disturbed wetland and the associated wetland mitigation sites (Ecology 2008a). The 8th Street Wetland has a 15-point difference in total function score, with at least 14 points necessary. The South Lake and Central Lake Wetlands have 26- and 28-point differences in total function score, respectively, with at least 14 points necessary. The North Lake Wetland has a 47-point difference in total function score, with at least 7 points necessary, and the BNSF East Wetland has a 32-point difference in total function score, with at least 12 points necessary.

The four wetlands that do not meet the statistically significant criteria of a lift in functions are the four Category II wetlands with existing moderate to high functional score values. The Mercer Slough Wetland has a -1 point difference in total function score, with at least 19 points necessary. The Bellefield South and Bellefield North Wetlands have 2- and 3-point differences in total function scores, respectively, with at least 18 points necessary at both the Sweyolocken mitigation site and at the Mercer Slough/Bellefield mitigation site. The Kelsey Creek West Tributary Pond Wetland has a 6-point difference in total function score, with at least 21 points necessary.

3.3.1 Comparison Between Functions and Values of Disturbed Streams and Stream Mitigation Sites

The following assessment is a qualitative comparison that summarizes the functions of the four streams with permanent impacts associated with the Project: Wye Creek, Alcove Creek, Sturtevant Creek, and the Unnamed Tributary to Kelsey Creek, and the proposed stream mitigation activities. Relocating Wye Creek will restore the channel to a more level grade, with meandering features that resemble more natural conditions. The restoration will also result in replacing the deeply incised banks and the silt and sand substrate with more natural gravel and cobble substrate. A currently subsurface portion of the channel will be daylighted, providing a longer stream system for fish and aquatic habitat. Riparian

buffer conditions will also be restored and improved by removing nonnative species and planting native vegetation.

Relocating Wye Creek will restore the channel to a more level grade, with meandering features resembling more natural conditions. The restoration will also result in replacing the deeply incised banks and the silt and sand substrate with more natural gravel and cobble substrate. A currently subsurface portion of the channel will be daylighted, providing a longer stream system for fish and aquatic habitat. Riparian buffer conditions will also be restored and improved by removing nonnative species and planting native vegetation.

The relocation and restoration activities described above for Wye Creek also apply as mitigation measures for shading impacts to Alcove Creek. Proposed Wye Creek restoration and relocation habitat features will provide higher quality stream channel characteristics than currently exist in the reach of Alcove Creek adjacent to 112th Avenue SE that will be shaded by the guideway bridge.

The reach of Sturtevant Creek that will be disturbed by the Project is a linear channel with vertical, incised banks dominated by fill material, and the channel substrate is dominated by sand and silt and angular rocks. The riparian zone is only a few feet wide and is dominated by nonnative invasive shrub and weed species with very little shade and woody debris recruitment potential. The relocation and restoration activities will result in a stream channel with higher quality habitat features compared to existing conditions. Shortening the existing downstream culvert will provide a longer reach of stream system for fish and aquatic habitat. Riparian buffer conditions will also be restored and improved by removing nonnative species and planting native tree and shrub vegetation. Proposed enhancement of a portion of the West Tributary to Kelsey Creek will result in a similar improvement of habitat conditions compared to the existing conditions of Sturtevant Creek.

Replacing the existing downstream culvert was not proposed for Sturtevant Creek because it is unlikely to have migratory fish access restored all the way to Lake Bellevue due to existing downstream culverts outside the Project area, including under I-405. Instead, installation of a fish passage culvert on Goff Creek that will be suitable for use in a proposed future realignment and restoration of Goff Creek is proposed. Providing fish passage at Goff Creek is preferable, due to the existence of plans for restoration of the Goff Creek/Kelsey Creek system (Bel-Red Plan) and the fact that no similar plan exists to restore fish passage to Sturtevant Creek downstream of the proposed impacts.

The reach of the Unnamed Tributary to Kelsey Creek that will be disturbed by the Project resembles a ditch feature located between 136th Place NE and commercial development. The banks are dominated by fill material, and the channel substrate is dominated by sand and silt and angular rocks. The system is piped for at least several hundred feet upstream and downstream of the disturbed reach. The riparian zone is only a few feet wide and is dominated by mowed grass, and there is no documented fish use of the system. Proposed enhancement of Coal Creek will be a significant improvement compared to existing conditions of this system. The Coal Creek mitigation site supports a variety of fish and salmon species, and there are several miles of upstream habitat that flows through healthy forested riparian

habitat in open space conservation. Proposed enhancements will further improve habitat conditions for fish and other aquatic wildlife.

3.4 Goals, Objectives, and Performance Standards

The following section identifies goals, objectives and performance standards in order to track and measure whether the mitigation and restoration sites are successful.

3.4.1 Goal 1: Restore Wetland Hydrology at the Sweyolocken and West Tributary Mitigation Sites

Objective 1-1: Wetland hydrology will be restored at the **Sweyolocken Mitigation Site** by filling two agricultural ditches and removing culverts and other associated drainage infrastructure that is related to historical agricultural use within the site.

Performance Standard 1: Post-construction monitoring and surveying indicates that grading was completed according to the approved mitigation plans or approved modification of those plans.

Performance Standard 2: In years of normal precipitation within the intended wetland area, the area will be inundated or soils will be saturated to within 12 inches of the soil surface for at least 12 percent of the growing season as measured in the spring of years 1,2,3, and 5.

Performance Standard 3: Hydroperiod of areas between the two restored ditches at the site will mimic the surrounding wetland areas determined from digging soil pits and measuring water levels as measured in spring and summer of years 1,2,3, and 5.

Objective 1-2: Wetland hydrology will be restored at the **West Tributary Mitigation Site** by removing fill material and creating a hydrologic connection between the wetland and stream system.

Performance Standard 1: Post-construction monitoring and surveying indicates that grading was completed according to the approved mitigation plans or approved modification of those plans.

Performance Standard 2: Soils will be saturated to the surface, or standing water will be present within 12 inches of the surface for at least 12 percent of the growing season in years when rainfall meets or exceeds the 30-year-average.

Performance Standard 3: The created wetland will be delineated in the spring of Years 2 and 5 (using current accepted methodologies) to ensure the size of the actual wetland is the same or greater than the designed wetland. Wetland soil characteristics may not be fully formed at that time; therefore, best professional judgment, topography, and other field characteristics will be used to determine the wetland boundary.

Objective 1-3: Increase surface roughness at the **Sweyolocken and West Tributary Mitigation Sites**.

Performance Standard 1: A total of five to ten microtopographic features (tip-up mounds) ranging from approximately 12 to 24 inches below existing grades to an approximate maximum of 24 inches above existing grades will be created and documented in the as-built plans. Mounds of

each feature will be a minimum of 10 inches high, and troughs will be a minimum of 8 inches deep (in comparison to the average surrounding ground surface elevation).

3.4.2 Goal 2: Establish Native Plant Communities at the Sweyolocken, Mercer Slough/Bellefield, Sturtevant Creek, and West Tributary Mitigation Sites

Objective 2-1: Plant communities will be restored and enhanced by installing native trees, shrubs, and emergent species.

Performance Standard 1: Average survival of all planted stock will be at least 90 percent at the end of Year 1.

Performance Standard 2: Native wetland woody vegetation species density shall be at least four specimens per 100 sf at the end of Year 3. Native wetland woody vegetation species cover shall be, at least 50 percent by Year 5. Sites requiring 10 years of monitoring shall reach a minimum 70 percent cover by Year 10.

Performance Standard 3: Native upland woody vegetation species cover shall be at least 20 percent by Year 3 and at least 40 percent by Year 5. Cover at sites to be monitored for 10 years will reach a minimum 70 percent cover by Year 10.

Performance Standard 4: Native herbaceous coverage within designated emergent wetland areas shall be at least 50 percent by Year 2, 70 percent by Year 3, and 100 percent by Year 5.

Performance Standard 5: A minimum of 19 desirable native plant species are present in the mitigation sites by the end of Year 5.

Performance Standard 6: Invasive, nonnative plant species are maintained at levels below 20 percent cover averaged over the entire site. Species such as creeping buttercup may not necessarily be included in invasive cover standards as long as those species do not interfere with long-term goals.

3.4.3 Goal 3: Create Stable Channels at the Sturtevant Creek and Restore Reaches at the West Tributary and Coal Creek Mitigation Sites that Increase Habitat Diversity and Channel Forming Processes

Objective 3-1: Recreate 567 linear feet of stream channel at the **Sturtevant Creek Mitigation Site** west of the existing stream channel.

Performance Standard 1: Post-construction monitoring and survey indicates that grading was completed according to the approved mitigation plans.

Objective 3-2: Channel conditions and in-stream features at the **West Tributary Mitigation Site** are stable at a range of flows from the summer low flow to the 2-year peak flow.

Performance Standard 1: Soils above the OHWM will be stable with established vegetation.

Performance Standard 2: After construction and for the duration of the 10-year monitoring period, channel bank material will consist of specified gradations of cobble. (Erosion shall be limited to minimize channel migration into native soils. Fine sediment accumulation is anticipated, but material smaller than “pebbles” (based on Wentworth 1922) will not cover more than 50 percent of the channel below OHWM during spring observations in years 1-3,5,7 and 10.)

Objective 3-3: Improve aquatic habitat at the West Tributary and Coal Creek Sites.

Performance Standard 1: Evidence of soil scour above the banks or significant bank erosion is not visible after flows up to and including the 10 percent recurrence flow (10-year flood) during spring observations in years 1 to 3, 5, 7, and 10.

Performance Standard 2: Evidence (rack marks, leaf staining, sediment deposition, etc.) of a surface water connection between the stream and wetland is visible at Kelsey Creek during spring observations in years 1 to 3, 5, 7, and 10.

Performance Standard 3: After construction, and for the duration of the 10-year monitoring period, pool and riffle features are stable and located as shown on the as-built plans during spring observations in years 1 to 3, 5, 7, and 10.

Objective 3-4: Improve geomorphologic function at the West Tributary, Coal Creek, and Sturtevant Creek Mitigation Sites.

Performance Standard 1: Anchored LWD at West Tributary and Coal Creek is secured to withstand a 20-year flood.

Performance Standard 2: After construction and for the duration of the 10-year monitoring period, channel banks material will consist of gravels and cobble suitable to support benthic macroinvertebrate species at the West Tributary, Coal Creek, and Sturtevant Creek mitigation sites. Fine sediment accumulation is anticipated but material smaller than “pebbles” (based on Wentworth 1922) will not cover more than 50% of the channel below OHWM during spring observations in years 1 to 3, 5, 7, and 10.

Performance Standard 3: After construction, and for the duration of the 10-year monitoring period, riparian vegetation is established as described in Goal 2 at all three sites, unless an unusual high flow event (20-year flood or greater) occurs.

Performance Standard 4: After construction, and for the duration of the 10-year monitoring period, pool and riffle features are stable at the West Tributary Migration Site, unless an unusual high flow event (20-year flood or greater) occurs. At least two pools and two riffles will be present after construction, and for the duration of the 10-year monitoring period.

Performance Standard 5: Erosion shall be limited to minimize channel migration into native soils at all three sites. No large slumps or major bank failures are observed during the 10-year monitoring period, unless an unusual high flow event (20-year flood or greater) occurs.

3.4.4 Goal 4: Improve Wildlife and Aquatic Habitat at the Sweyolocken, Mercer Slough/Bellefield, Sturtevant Creek, and West Tributary Mitigation Sites

Objective 4-1: Provide habitat structure to benefit a variety of fauna, including, but not limited to song birds, cavity-nesting birds, insects, and mammals, by incorporating habitat features at the Sweyolocken, West Tributary, and the Mercer Slough/Bellefield Mitigation Sites.

Performance Standard 1: There will be at least 17 habitat features per acre (1 piece/2,500 sf) including down woody material (logs, rootwads, etc.), stumps, snags, brush piles, boulder piles, and constructed cavities in stumps and down logs at the Sweyolocken and West Tributary mitigation sites. The amount of down woody material that will be incorporated at the Mercer Slough/Bellefield mitigation site will be determined based on available space within the site. These features will be documented in the as-built plan.

Performance Standard 2: Install one snag with a bat flange per 25,000 sf at the Sweyolocken and West Tributary mitigation sites.

Performance Standard 3: Evidence of wildlife use of the sites will be documented. This may include scat, nests, visual observations, tracks, or other evidence.

3.4.5 Goal 5: Restore Wetland, Stream, and Buffer Areas Temporarily Impacted during Construction to Pre-existing or Better Conditions

Objective 5-1: Wetland hydrology will be restored at all temporarily impacted wetland sites by adding or removing fill material and restoring pre-construction elevations.

Performance Standard 1: Post-construction monitoring and survey indicates that grading was completed according to the approved mitigation plans or approved modification of those plans. Soils are decompacted to be no more than 80 percent of maximum compaction.

Performance Standard 2: Soils are saturated to the surface, or standing water is present within 12 inches of the surface for at least 12 percent of the growing season in years when rainfall meets or exceeds the 30-inch average.

Objective 5-2: Plant communities will be restored by installing native trees, shrubs, and emergent species.

Performance Standard 1: Average survival of all planted stock will be at least 90% at the end of Year 1.

Performance Standard 2: Native wetland woody vegetation species cover shall be at least 25 percent by Year 3, at least 50 percent by Year 5.

Performance Standard 3: Native upland woody vegetation species cover shall be at least 20 percent by Year 3, at least 40 percent by Year 5.

Performance Standard 4: Native herbaceous coverage within designated emergent wetland areas shall be at least 50 percent by Year 2, 70 percent by Year 3, and 100 percent by Year 5.

Performance Standard 5: A minimum of 19 native plant species shall be in the mitigation sites by the end Year 5.

Performance Standard 6: Invasive, nonnative plant species are maintained at levels below 20 percent total cover. Species such as creeping buttercup may not necessarily be included in invasive cover standards as long as those species do not interfere with long-term goals.

3.4.6 Goal 6: Improve habitat quality, habitat diversity and diversity of prey resources in the Coal Creek Restoration Site

Objective 6.1: Pool and Riffle habitat will increase relative to glide habitat.

Performance Standard 1: LWD installations will be in the wetted channel and within the bank full channel to improve sorting of bed load materials, and improve channel forming processes.

Performance Standard 2: Two and 5 years after construction, the number of pools in the reach will increase relative to current conditions.

Performance Standard 3: Two and 5 years after construction, the number of riffles in the reach will increase relative to current conditions.

Objective 6.2: Improve habitat conditions in the reach for benthic invertebrates

Performance Standard 1: LWD installations will be in the wetted channel and within the bank full channel to improve sorting of bed load materials, and improve channel forming processes.

3.5 Monitoring, Maintenance, and Contingency Plan

3.5.1 Baseline Monitoring

Baseline monitoring at Sturtevant Creek, West Tributary Kelsey Creek, and Coal Creek will occur. The biologists will collect data regarding stream conditions, such as bank full width, substrate composition, and vegetation structure and cover. This information will document how the stream systems functioned prior to relocation and daylighting and evaluate success of the mitigation projects.

3.5.2 Post-construction Monitoring

An as-built monitoring report will be prepared and submitted to the City, WDFW, Ecology, and the Corps within 6 months after mitigation elements are installed. Mitigation Performance monitoring will be conducted annually for a period of 5 years for all communities restored along the Project corridor. These areas will have annual monitoring reports submitted to the City, WDFW, Ecology, and the Corps in Years 1 through 5.

The Sweyolocken, West Tributary, and Mercer Slough/Bellefield sites will be monitored for 10 years. Annual reports will be submitted to the City, the Corps, Ecology, and WDFW in Years 1 through 5, 7, and 10.

Monitoring reports will follow the format outlined in Corps regulatory guidance letter 08-03 and will document how the Project is meeting the performance standards outlined above. If one or more of the performance standards are not met, the report will identify actions to be taken in order to meet the standard.

3.5.3 As-built or Year 0 Monitoring

A post-construction assessment will be conducted upon completing the mitigation plan construction, and a report including record drawings will be submitted to agencies with jurisdiction. The purpose of this assessment will be to determine whether the site conditions are consistent with the approved plan, document any changes that occurred during construction, and establish baseline conditions for future monitoring.

3.5.4 Methods to Monitor Progress in Attaining the Performance Standards

Each monitoring report will include an evaluation of the mitigation project to ensure that the goals, objectives, and performance standards are being met. The performance standards above will be monitored using the following methods.

3.5.5 Wetland Hydrology

Indicators of wetland hydrology will be recorded, including ponding, water marks, water-stained leaves, and soil saturation. Water elevations in test pits or wells (if installed) will be recorded.

3.5.6 Stream Hydrology and Condition

Regular monitoring of the, bank stability, LWD structures, pool and riffle structures, and vegetation will occur at the Coal Creek, Sturtevant, and West Tributary sites. At the Coal Creek and West Tributary Sites, additional monitoring of the stability of LWD structures, pool and riffle structures, and wetland connectivity at high flow will occur.

3.5.7 Vegetation Monitoring

Monitoring quadrats or transects will be established for each site during the as-built monitoring. Monitoring protocols could include 10-meter square Quadrats or transects. Transects will include both wetland and buffer, and will be located to cross as many plant communities as possible in the mitigation areas.

3.5.7.1. Species Diversity

During fall vegetation monitoring events, the percent areal cover of shrubs and trees could be evaluated through the use of point-intercept sampling methodology. Using this methodology, a tape will be extended between two permanent markers. Shrubs and trees intercepted by the tape will be identified, and the intercept distance recorded. Species diversity will then be calculated to determine the number of species intercepted as a total proportion of the tape length.

3.5.7.2. Plant Survival

During the first fall monitoring event, plant survival will be evaluated within each of the sampling transect locations. Percent survival of shrubs and trees will be evaluated in a 10-foot belt along the established transect. The species and location of shrubs and trees within this belt will be recorded. The established vegetation sampling transects will aid in determining the success of plant establishment. Monitoring and calculations to determine percent survival will only occur in Year 1.

3.5.7.3. Invasive Species

During all monitoring events, undesirable plant species will also be measured within each sampling location. Invasive plants will be maintained at levels below 20 percent total cover. Removal of these species will occur regularly to prevent infestations. Removal will occur by hand whenever possible. Undesirable species include, but are not limited to Scot's broom, Himalayan and evergreen blackberry, reed canarygrass, purple loosestrife (*Lythrum salicaria*), hedge bindweed (morning glory), Japanese knotweed, and creeping nightshade. Naturally colonizing and aggressive native species, including reed canarygrass, red alder, Douglas' spirea, and Cattails, may also be removed if they threaten to crowd out planted species to the extent that performance standards for species diversity cannot be met. The presence of any nonnative knotweeds (*Polygonum cuspidatum*, *P. polystachyum*, *P.sachalinense*, and *P. bohemicum*) and purple loosestrife will initiate the invasive species maintenance actions.

3.5.8 Habitat Use

During each monitoring event, evidence that mitigation sites are being used by birds, mammals, amphibians, or fish will be recorded. This includes the presence of scat or other physical evidence of species presence, as well as sightings, vocalizations etc. Formalized wildlife monitoring will not occur.

3.5.9 Monitoring Schedule

Monitoring events will be conducted according to the schedule presented in Table 3-15.

Table 3-15 Projected Calendar for Performance Monitoring and Maintenance Events

Year	Date	Maintenance Review	Performance Monitoring	Report Due to Agencies
0 (BA)	Soon after construction is complete.	X	X	X
1	Spring	X	X	
	Fall	X	X	X
2	Spring	X		
	Fall	X	X	X
3	Spring	X		
	Fall	X	X	X

Year	Date	Maintenance Review	Performance Monitoring	Report Due to Agencies
4	Spring	X		
	Fall	X	X	X
5	Spring	X		
	Fall	X	X	X
6	Spring	X		
	Fall			
7	Spring	X		
	Fall	X	X	X
8	Spring	X		
	Fall			
9	Spring	X	X	
	Fall	X		
10	Spring	X		
	Fall	X	X	X*

Notes:

* Obtain final approval from Corps (presumes that performance criteria are met).

BA = Baseline Assessment following construction completion.

3.5.10 Maintenance Actions

Maintenance will be performed regularly to address conditions that could jeopardize the success of the mitigation sites. During regular monitoring visits (schedule shown in Table 3-12), any necessary maintenance actions will be identified and reported to the landscape maintenance contractor.

Established performance standards for the Project will be compared to the monitoring results to judge the success of the mitigation project. If there is a significant problem with achieving the performance standards, Sound Transit shall develop a corrective action plan. Corrective actions may include, but are not limited to additional plant installation, erosion control, adjustment to hydrology, and plant substitutions of type, size, quantity, and location. On-site maintenance and remedial action will be implemented immediately upon completion of the monitoring event (unless otherwise specifically indicated below). Typical maintenance activities will include, but are not limited to the following:

- During Year 1, replace all dead plant material to achieve a minimum of 90 percent survival.
- Mitigation plantings will be watered at a minimum rate of 1 inch of water between June 15 and October 15 (or as needed) during the first year after installation. If replacement plantings are installed following Year 1, then the newly installed plants shall also be watered at a rate of 1 inch of water every week between June 15 and October 15 for the first year after planting.
- Replace dead plants with the same species or a substitute species that meets the goals and objectives of the mitigation plan, subject to the approval of Sound Transit.

- Re-plant area after reason for failure has been identified and corrected (e.g., moisture regime, poor plant stock, disease, shade/sun conditions, wildlife damage, etc.).
- Remove and control weedy or exotic invasive plants (e.g., Scot's broom, reed canarygrass, Himalayan blackberry, bindweed, purple loosestrife, etc.). Use of herbicides or pesticides within the mitigation area would only be implemented if other measures failed or were considered unlikely to be successful. Mulch rings should be maintained on trees and shrubs, until they become established.
- Remove trash and other debris.
- Prune woody plants as necessary to meet the mitigation plan's goals and objectives (e.g., thinning and removing dead or diseased portions of trees and shrubs).
- Make minor excavations by hand, as needed and after consulting with Sound Transit, to correct surface drainage or soils moisture conditions.

3.5.11 Contingency Plan

Contingency plans describe what actions can be taken to correct site deficiencies. Mitigation goals, objectives, and performance standards create a baseline by which to measure if the site is performing as proposed and whether or not a contingency plan is necessary. All contingencies cannot be anticipated. The contingency plan will be flexible so that modifications can be made if portions of the final design do not produce the desired results. Problems or potential problems will be evaluated by a qualified wetland ecologist, Sound Transit, the City, WDFW, the Corps, and Ecology. Specific contingency actions will be developed, agreed to by consensus, and implemented based on all scientifically and economically feasible recommendations.

Contingency actions may include the following:

- Re-grading or modifying hydrologic sources to address problems with wetland or stream hydrology, which may include the following:
 - Changing existing, ditches, watercourses, and/or flow patterns
 - Revising grades to direct sheetflow and affect areas of inundation
 - Adding in stream features (LWD, weirs, or boulders) to modify/improve flow or bank stability
- Additional soil amendments
- Modifying grades to correct too low or too high elevations
- Providing fencing to prevent vandalism or other damage caused by humans
- There are several reaches of Coal Creek that have been identified as candidate sites for restoration or mitigation. In the event that additional or alternate sites are needed to fully mitigate project-related impacts to stream resources similar mitigation actions in one or more of these reaches would be implemented.

Establishing a stable wetland and stream hydrology across the site is one of the most critical factors in controlling the success of the mitigation site. Sound Transit will closely monitor the effect of the planned alterations to surface water flows and determine if the resultant changes in the hydrologic regime of the site meet modeled expectations. If not, the alterations to the surface water flows, the planting plan, or to both should be changed prior to plant installation. If desirable wetland hydrology is achieved initially but is not found to be stable throughout the monitoring period, additional contingency measures may be required once the cause(s) of the instability is determined.

Sound Transit will implement contingency plans on an as-needed basis. Contingency plans will be developed for review and approval by regulatory agencies, as appropriate. In addition, implemented contingency plans will be described in the next monitoring report. Contingency plans shall be submitted by December 31 of the year in which deficiencies are discovered. A contingency plan, if required, will be submitted before construction activities.

If, during the monitoring program, other maintenance needs are identified as necessary to ensure the success of the mitigation Project, they will be implemented, unless generated by third parties or acts of nature. These include soil testing and additional soil amendments or the use of broadcast fertilizer if approved in advance by the City, the Corps, and Ecology. Specific contingency actions relative to interim performance standards are identified in Tables 3-16 and 3-17. These interim standards will be used internally by Sound Transit to determine if the sites are on track to meet the main performance standards. Reports will only indicate whether the sites are meeting, are not meeting, or are on track to meet the main performance standards.

The mitigation proposed above is anticipated to be adequate to fully compensate for unavoidable impacts to streams, wetlands and their buffers. Sound Transit has identified an opportunity for additional wetland, and possibly stream mitigation north of SE 15th Street and East of 112th Avenue SE. The site is currently an upland buffer adjacent to the Mercer Slough wetland complex that could be excavated to create additional wetland or aquatic habitat. The site would have similar hydrology to the adjacent wetlands created by flows in Mercer Slough and maintained by the backwatering effect of Lake Washington. The site could provide refuge for juvenile fish out migrating from the Kelsey Creek watershed and could be designed to provide habitat for additional species if desired. Current plans are to restore buffer vegetation in this area only, but additional options to create wetland or aquatic habitat as mitigation will be developed should a need arise.

Table 3-16 Potential Contingency Actions for the Wetland Mitigation Site

Design Feature	Monitoring Year(s)	Interim Performance Standards	Contingency Action ¹
Forest/ Shrub Wetland Plantings	1	Greater than 80 percent survival of planted stock	None
Emergent Wetland Plantings	1	Total cover 20 percent and at least 10 percent cover by the emergent wetland species planted	None
		Total cover less than 20 percent and less than 10 percent cover by the emergent wetland species planted	Re-evaluate the suitability of the plant species for site conditions and re- establish, if necessary. Consider make- up of cover species and, if functioning, do nothing. Consider use of alternate species. Undertake additional monitoring.
Emergent Wetland Plantings	2	Total cover 40 percent and at least 20 percent cover by the emergent wetland species planted	None
		Total cover less than 25 percent and less than 10 percent cover by the emergent wetland species planted	Re-evaluate the suitability of the plant species for site conditions and re- establish, if necessary. Consider make- up of cover species and, if functioning, do nothing. Consider use of alternate species. Undertake additional monitoring.
	5	Total cover by emergent wetland species at least 70 percent	None
		Total cover by emergent wetland species less than 70 percent	Re-evaluate the suitability of the plant species for site conditions and re- establish, if necessary. Consider make- up of cover species and, if functioning, do nothing. Consider use of alternate species. When invasive species (reed canarygrass) represent greater than 20 percent cover, control of this species in accordance with City of Bellevue “Environmental Best Management Practices” (Ordinance 5680, 6-26-06, §3)

Design Feature	Monitoring Year(s)	Interim Performance Standards	Contingency Action ¹
Hydrologic Regime	1 to 5	In forested/shrub wetland areas, saturation within 6 to 16 inches of surface from December through April (normal rainfall years)	Evaluate reasons for failure. Possible solutions include modification of off-site drainage to wetland, revision of planting plan to correlate to the hydrologic regime, or addition of water level control structures to regulate water levels.

Note:

1 Contingency actions listed in Table 3-9 are only a subset. All contingency actions discussed above should be considered and the appropriate actions taken based on an understanding of the actual causes of poor performance.

Table 3-17 Potential Contingency Actions for the Stream Mitigation Site

Design Feature	Monitoring Year(s)	Interim Performance Standards	Contingency Action ¹
Riparian Buffer Plantings	1	Total cover 20 percent and at least 10 percent cover by the emergent wetland species planted	None
		Total cover less than 20 percent and less than 10 percent cover by the emergent wetland species planted	Re-evaluate the suitability of the plant species for site conditions and re-establish, if necessary. Consider makeup of cover species and, if functioning, do nothing. Consider use of alternate species. Undertake additional monitoring.
	2	Total cover 40 percent and at least 20 percent cover by the emergent wetland species planted	None
		Total cover less than 25 percent and less than 10 percent cover by the emergent wetland species planted	Re-evaluate the suitability of the plant species for site conditions and re-establish, if necessary. Consider makeup of cover species and, if functioning, do nothing. Consider use of alternate species. Undertake additional monitoring.
	5	Total cover by emergent wetland species at least 70 percent	None
		Total cover by emergent wetland species less than 70 percent	Re-evaluate the suitability of the plant species for site conditions and re-establish, if necessary. Consider makeup of cover species and, if functioning, do nothing. Consider use of alternate species. When invasive species (reed canarygrass) represent greater than 20 percent cover, control of this species in accordance with City of Bellevue "Environmental Best Management Practices" (Ordinance 5680, 6-26-06, §3)

Design Feature	Monitoring Year(s)	Interim Performance Standards	Contingency Action ¹
Pools	1,2,5, 10	Area and depth of pools are within 10% of as-built dimensions	None
		Area and depth of pools are less than 90% of as-built condition	Determine the cause(s) of sedimentation and address with adjustments to large woody debris structures , installation of additional large woody debris or other measures
		Pool scour is causing bank erosion	Determine the cause(s) of scour and address with adjustments to large woody debris structures or other measures
Riffles	1,2,5, 10	Riffle length and substrate size (D_{50}) ² are within 20% of as-built condition	None
		Riffle length is less than 80% of as-built condition	Determine the cause(s) of grade change and address with grading or substrate adjustments
		Riffle substrate size is 20% greater or smaller than as-built condition	Determine if the change is impacting stream functions such as benthic production, if so address
Bank Stability	1,2,5, 10	Banks are stable	None
		Erosion on banks is revealing native soils	Determine the cause(s) of erosion and address with greater channel roughness, greater capacity, or decreased slope between structures
Wetland Connectivity	1,2,5, 10	Evidence of surface water connections under high flow exist	None
		Wetland connection is silted in	Determine the cause(s) of sedimentation and address with adjustments to large woody debris structures , installation of additional large woody debris or other measures
		Wetland connection is eroding	Determine the cause(s) of erosion and address with greater channel roughness, greater capacity, or decreased slope between wetland and stream.

Notes:

1 Contingency actions listed in Table 3-10 are only a subset. All contingency actions discussed above should be considered and the appropriate actions taken based on an understanding of the actual causes of poor performance.

2 D_{50} refers to the average diameter of the average sized or 50th percentile piece of gravel or cobble across the wetted channel width.

3.5.12 Long Term Management Plan

A long-term management plan will be developed for the mitigation sites. The objective of the long-term mitigation plan is to ensure that the mitigation site is maintained and monitored after the 10-year active site management and monitoring period has ended. Long-term monitoring will be required for up to 10 years to ensure the ecological function of the established mitigation site is maintained. Reports will include the results of qualitative assessments and descriptions of any management activities implemented.

The long-term monitoring plan will identify specific performance standards that will be monitored to assess elements of the site that pertain to overall site condition and ongoing ecological function. The long-term management plan and subsequent long-term monitoring plan for each of the mitigation areas will describe specific objectives and related performance standards to provide information about the following site elements:

- Qualitative assessment of overall site condition
- Photo documentation from established photo points
- Qualitative assessment of King County-listed noxious weeds and other nonnative invasive weeds
- Sources of trash or vandalism
- The condition of fences and signage
- Maintenance implemented to correct issues identified during monitoring activities

A draft of the long-term management plan will be submitted to the Corps and Ecology for approval prior to the conclusion of the ten year monitoring period for the mitigation sites.

4.0 References

- Anchor QEA, 2014. *Sound Transit East Link Extension Project Wetland, Stream, and Jurisdictional Ditch Delineation Report*. Prepared for H-J-H Final Design Partners and Sound Transit. August 2014.
- Axis Environmental, LLC and CH2M HILL, 2010. *East Link Project Biological Assessment*. Prepared for Sound Transit. October 2010.
- Brown, E.R., (ed.). 1985. *Management of Wildlife Habitats in Forests of Western Oregon and Washington*, Vols. 1 and 2.
- Carrsaco, Yvan, Richard Hicks, Natasha Luhrs, Penny Manning, Matthew Riewe, Tara Waggoner, and Warren Gold. Study of Mercer Slough. Accessed online at <http://www.rlh.newproject.us/Webpage/MercerSlough6.html> September, 30, 2013.
- City of Bellevue, 2013a. Bellevue City Code. URL: <http://www.codepublishing.com/wa/bellevue/> (accessed September 2013).
- City of Bellevue, 2013b. Critical Areas Maps. URL: <http://nwmaps.net/mapsearch.htm?theme=environmental> (accessed September 2013).
- Corps (U.S. Army Corp of Engineers), 2010. *Regional Supplement to the Corps of Engineers Wetland Delineation Manual: Western Mountains, Valleys, and Coast Region*.
- Cowardin, L.M., V. Carter, F.C. Golet, and E.T. LaRoe, 1979. *Classification of Wetlands and Deepwater Habitats of the United States*. Publ. # FWS/OBS-79/31. U.S. Fish and Wildlife Service.
- Cramer, Michelle L., 2012. *Stream Habitat Restoration Guidelines*. Michelle Cramer, managing editor. Co-published by the Washington Departments of Fish and Wildlife, Natural Resources, Transportation and Ecology, Washington State Recreation and Conservation Office, Puget Sound Partnership, and the U.S. Fish and Wildlife Service. Olympia, Washington.
- David Evans and Associates, Inc. 2007. *City of Bellevue Lower Coal Creek Sediment Pond Critical Areas Report*. July 20, 2007.
- Ecology (Washington State Department of Ecology), 1997. *Washington State Wetland Identification and Delineation Manual*.
- Ecology, 2008a. Washington State Wetland Rating Form – Western Washington, Version 2.
- Ecology, 2008b. *Using the Wetland Rating System in Compensatory Mitigation - Focus Sheet*. Olympia, Washington.
- Ecology, 2015. Environmental Information; Watersheds; WRIA 8 Lower Crab. Cited: May 22, 2015. Available from: <http://www.ecy.wa.gov/services/gis/maps/wria/number/wria8.htm>
- Ecology (Washington State Department of Ecology), U.S. Army Corps of Engineers Seattle District, and U.S. Environmental Protection Agency Region 10, 2006. *Wetland*

- Mitigation in Washington State – Part 1: Agency Policies and Guidance (Version 1)*. Washington State Department of Ecology Publication #06-06-011a. Olympia, Washington, March 2006.
- Environmental Laboratory, 1987. *U.S. Army Corps of Engineers Wetland Delineation Manual*. Technical Report Y-87-1. U.S. Army Corps of Engineers Waterways Experiment Station, Vicksburg, Mississippi.
- ESA, 2013. *Lower Coal Creek Off-line Sediment Pond Project, Year 3 Buffer Vegetation Monitoring*. Prepared for the City of Bellevue Utilities Department. November 2013.
- FEMA (Federal Emergency Management Agency) 2005. Flood Insurance Study. King County, Washington and Incorporated Areas. Flood Insurance Study Number 53033CV002B. April 19, 2005.
- FTA (Federal Transit Authority) 2011. *Record of Decision for Central Puget Sound Regional Transit Authority's (Sound Transit) East Link Light Rail Transit Project*. King County, Washington. November 2011.
- Fox, M.J. and S.M. Bolton, 2007. A regional and geomorphic reference for quantities and volumes of instream wood in unmanaged forested basins of Washington State. *North American Journal of Fisheries Management* 27(1): 342-359.
- Franklin, J.F. and C.T. Dyrness, 1988. *Natural vegetation of Oregon and Washington*. Oregon State University Press. Corvallis, OR.
- G-Logics, Inc., 2009. *Additional Phase II Subsurface Assessment Safeway-Mid Mountain Property*. Prepared for the City of Bellevue. August 2009.
- Herrera (Herrera Environmental Consultants), 2006. *Bel-red Corridor Environmental Opportunities and Constraints*. Prepared for the City of Bellevue. January 26, 2006. Available from: <http://www.bellevuewa.gov/pdf/Transportation/AppendixC.pdf>
- Hruby, T., 2004. *Washington State Wetland Rating System for Western Washington: Revised*. Washington State Department of Ecology Publication #04-06-25.
- Kerwin, J., 2001. *Salmon and Steelhead Habitat Limiting Factors Report for the Cedar - Sammamish Basin (Water Resource Inventory Area 8)*. Washington Conservation Commission. Olympia, Washington.
- Larsen, E. M., editor, 1997. Management recommendations for Washington's priority species, Volume III: Amphibians and Reptiles. Washington Department of Fish and Wildlife, Olympia, Washington, USA.
- Larsen, E.M., J. M. Azerrad, and N. Nordstrom (eds.), 2004. *Management Recommendations for Washington's Priority Species, Volume IV: Birds*. Washington Department of Fish and Wildlife, Olympia, Washington.
- Parametrix, 2012. *Critical Areas Report West Tributary Detention Pond 165 Enhancement Project*. City of Bellevue. December 2012.
- Rhithron, 2014. *Aquatic Invertebrate Assemblages and Biological Assessment of Stream Sites in the City of Bellevue, Washington: 2013*. Prepared for the City of Bellevue. June 2014.

Sound Transit, 2011. *East Link Light Rail Project Final Environmental Impact Statement and Technical Appendices*.

Sound Transit, 2013. *Design Criteria Manual Revision 3*. August 2013.

USDA (U.S. Department of Agriculture), 2013a. *Natural Resource Conservation Service (NRCS) Web Soil Survey*. Cited: February 1, 2013. Available from:
<http://websoilsurvey.nrcs.usda.gov/app>.

USDA, 2013b. *Hydric Soil List for Washington State*. USDA Soil Conservation Service. Cited: February 1, 2013. Available from:
http://www.nrcs.usda.gov/Internet/FSE_DOCUMENTS/nrcs143_023872.xls.

USFWS (U.S. Fish and Wildlife Service), 2013. *USFWS Wetlands Mapper for National Wetlands Inventory (NWI) Map Information*. Cited: February 1, 2013. Available from:
<http://wetlandsfws.er.usgs.gov>.

WDFW (Washington Department of Fish and Wildlife). 2013a. Priority Habitats and Species Maps.

WDFW, 2013b. SalmonScape Interactive mapper – Salmon presence; forage fish spawning habitat. Available from: <http://wdfw.wa.gov/mapping/salmonscape/>. Accessed on: February 2, 2013.

Watson, R. 2007. City of Bellevue Utilities Department Personal communication. March 9, 2007.

Wentworth, C.K., 1922. A scale of grade and class terms for clastic sediments. *Journal of Geology*, v. 30, p. 377-392.

Appendix A

Wetland and Stream Resource Maps



Appendix A

Wetland/Stream/Ditch Locations

Sound Transit East Link

Extension Project

Frame 1

- LEGEND**
- Stream Location¹
 - Stream Location²
 - Jurisdictional Ditch Location¹
 - Culvert Location²
 - Culvert Location (Estimated)³
 - Mercer Slough Flow Direction
 - Stream or Ditch Flow Direction
 - Stream Buffers⁴
 - Wetland Location¹
 - Non-delineated Wetland Areas⁵
 - Wetland Area Buffers⁴
 - Wetlands Sample Plot
 - Uplands Sample Plot
 - Water Bodies (King County)
 - Tax Parcels (King County)
 - Proposed Light Rail Alignment

- NOTES:**
1. Locations determined from field survey activities carried out by Anchor QEA, LLC, in 2013.
 2. City of Bellevue stream data.
 3. City of Bellevue data does not include culvert information for this stream.
 4. Wetland buffers and stream buffers have been modified to not extend over impervious areas or structures. Wetland and stream buffers may overlap in some areas.
 5. Non-delineated areas were approximated using available aerial imagery and were not accessible due to a lack of access or agreed right-of-entry.
 6. King County water body data were modified by Anchor QEA where necessary to match field-delineated ordinary high water mark (OHWM).

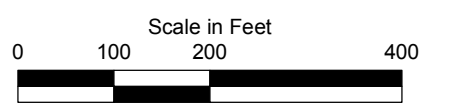

















V:\cas\jobs\120975-01\01_Sound_Transit_East_Link_Env_Support\Maps\2014_08\Appendix D Wetlands Maps August 27 2014 Draft.mxd eiverson 8/28/2014 11:26:12 AM



Appendix A Wetland/Stream/Ditch Locations Sound Transit East Link Extension Project Frame 2

LEGEND

-  Stream Location¹
-  Stream Location²
-  Jurisdictional Ditch Location¹
-  Culvert Location²
-  Culvert Location (Estimated)³
-  Mercer Slough Flow Direction
-  Stream or Ditch Flow Direction
-  Stream Buffers⁴
-  Wetland Location¹
-  Non-delineated Wetland Areas⁵
-  Wetland Area Buffers⁴
-  Wetlands Sample Plot
-  Uplands Sample Plot
-  Water Bodies (King County)
-  Tax Parcels (King County)
-  Proposed Light Rail Alignment





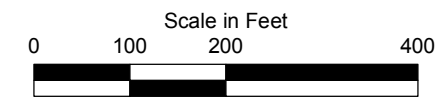











NOTES:

1. Locations determined from field survey activities carried out by Anchor QEA, LLC, in 2013.
2. City of Bellevue stream data.
3. City of Bellevue data does not include culvert information for this stream.
4. Wetland buffers and stream buffers have been modified to not extend over impervious areas or structures. Wetland and stream buffers may overlap in some areas.
5. Non-delineated areas were approximated using available aerial imagery and were not accessible due to a lack of access or agreed right-of-entry.
6. King County water body data were modified by Anchor QEA where necessary to match field-delineated ordinary high water mark (OHWM).



Appendix A
Wetland/Stream/Ditch Locations
Sound Transit East Link
Extension Project
Frame 3

LEGEND

-  Stream Location¹
-  Stream Location²
-  Jurisdictional Ditch Location¹
-  Culvert Location²
-  Culvert Location (Estimated)³
-  Mercer Slough Flow Direction
-  Stream or Ditch Flow Direction
-  Stream Buffers⁴
-  Wetland Location¹
-  Non-delineated Wetland Areas⁵
-  Wetland Area Buffers⁴
-  Wetlands Sample Plot
-  Uplands Sample Plot
-  Water Bodies (King County)
-  Tax Parcels (King County)
-  Proposed Light Rail Alignment

NOTES:

1. Locations determined from field survey activities carried out by Anchor QEA, LLC, in 2013.
2. City of Bellevue stream data.
3. City of Bellevue data does not include culvert information for this stream.
4. Wetland buffers and stream buffers have been modified to not extend over impervious areas or structures. Wetland and stream buffers may overlap in some areas.
5. Non-delineated areas were approximated using available aerial imagery and were not accessible due to a lack of access or agreed right-of-entry.
6. King County water body data were modified by Anchor QEA where necessary to match field-delineated ordinary high water mark (OHWM).

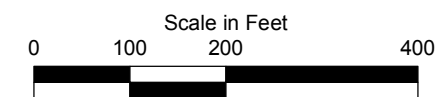



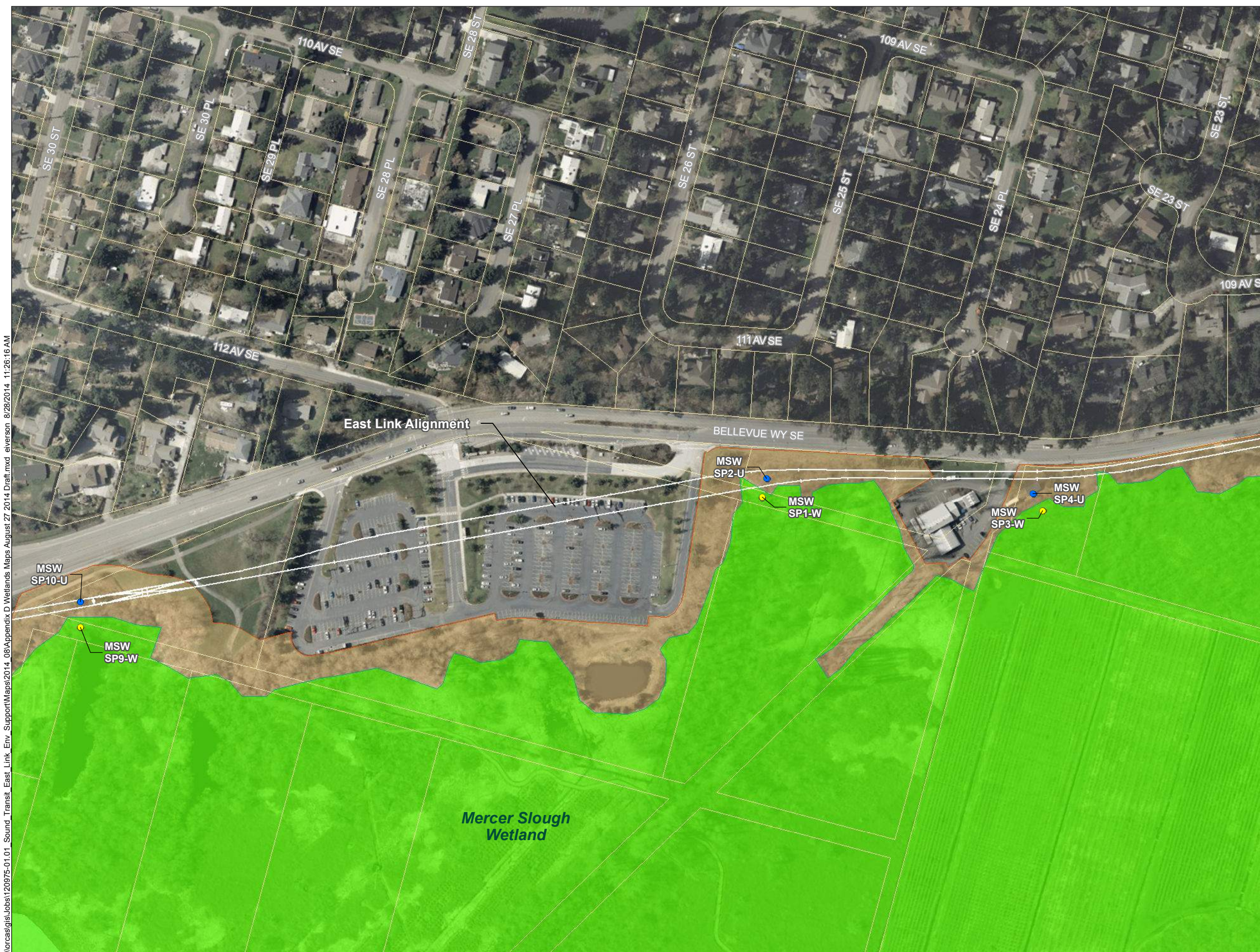



I:\projects\gis\20975-01\01_Sound_Transit_East_Link_Env_Support\Maps\2014_08\Appendix D Wetlands Maps August 27 2014 Draft.mxd eiverson 8/28/2014 11:26:16 AM



Appendix A
Wetland/Stream/Ditch Locations
Sound Transit East Link
Extension Project
Frame 4

LEGEND

-  Stream Location¹
-  Stream Location²
-  Jurisdictional Ditch Location¹
-  Culvert Location²
-  Culvert Location (Estimated)³
-  Mercer Slough Flow Direction
-  Stream or Ditch Flow Direction
-  Stream Buffers⁴
-  Wetland Location¹
-  Non-delineated Wetland Areas⁵
-  Wetland Area Buffers⁴
-  Wetlands Sample Plot
-  Uplands Sample Plot
-  Water Bodies (King County)
-  Tax Parcels (King County)
-  Proposed Light Rail Alignment

NOTES:

1. Locations determined from field survey activities carried out by Anchor QEA, LLC, in 2013.
2. City of Bellevue stream data.
3. City of Bellevue data does not include culvert information for this stream.
4. Wetland buffers and stream buffers have been modified to not extend over impervious areas or structures. Wetland and stream buffers may overlap in some areas.
5. Non-delineated areas were approximated using available aerial imagery and were not accessible due to a lack of access or agreed right-of-entry.
6. King County water body data were modified by Anchor QEA where necessary to match field-delineated ordinary high water mark (OHWM).

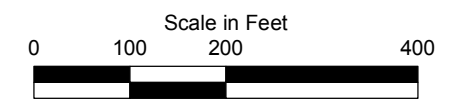















\orcas\gis\Jobs\120975-01\01_Sound_Transit_East_Link_Support\Maps\2014_08\Appendix D Wetlands Maps August 27 2014 Draft.mxd everson 8/26/2014 11:26:21 AM



Appendix A
Wetland/Stream/Ditch Locations
Sound Transit East Link
Extension Project
Frame 5

LEGEND

-  Stream Location¹
-  Stream Location²
-  Jurisdictional Ditch Location¹
-  Culvert Location²
-  Culvert Location (Estimated)³
-  Mercer Slough Flow Direction
-  Stream or Ditch Flow Direction
-  Stream Buffers⁴
-  Wetland Location¹
-  Non-delineated Wetland Areas⁵
-  Wetland Area Buffers⁴
-  Wetlands Sample Plot
-  Uplands Sample Plot
-  Water Bodies (King County)
-  Tax Parcels (King County)
-  Proposed Light Rail Alignment

NOTES:

1. Locations determined from field survey activities carried out by Anchor QEA, LLC, in 2013.
2. City of Bellevue stream data.
3. City of Bellevue data does not include culvert information for this stream.
4. Wetland buffers and stream buffers have been modified to not extend over impervious areas or structures. Wetland and stream buffers may overlap in some areas.
5. Non-delineated areas were approximated using available aerial imagery and were not accessible due to a lack of access or agreed right-of-entry.
6. King County water body data were modified by Anchor QEA where necessary to match field-delineated ordinary high water mark (OHWM).

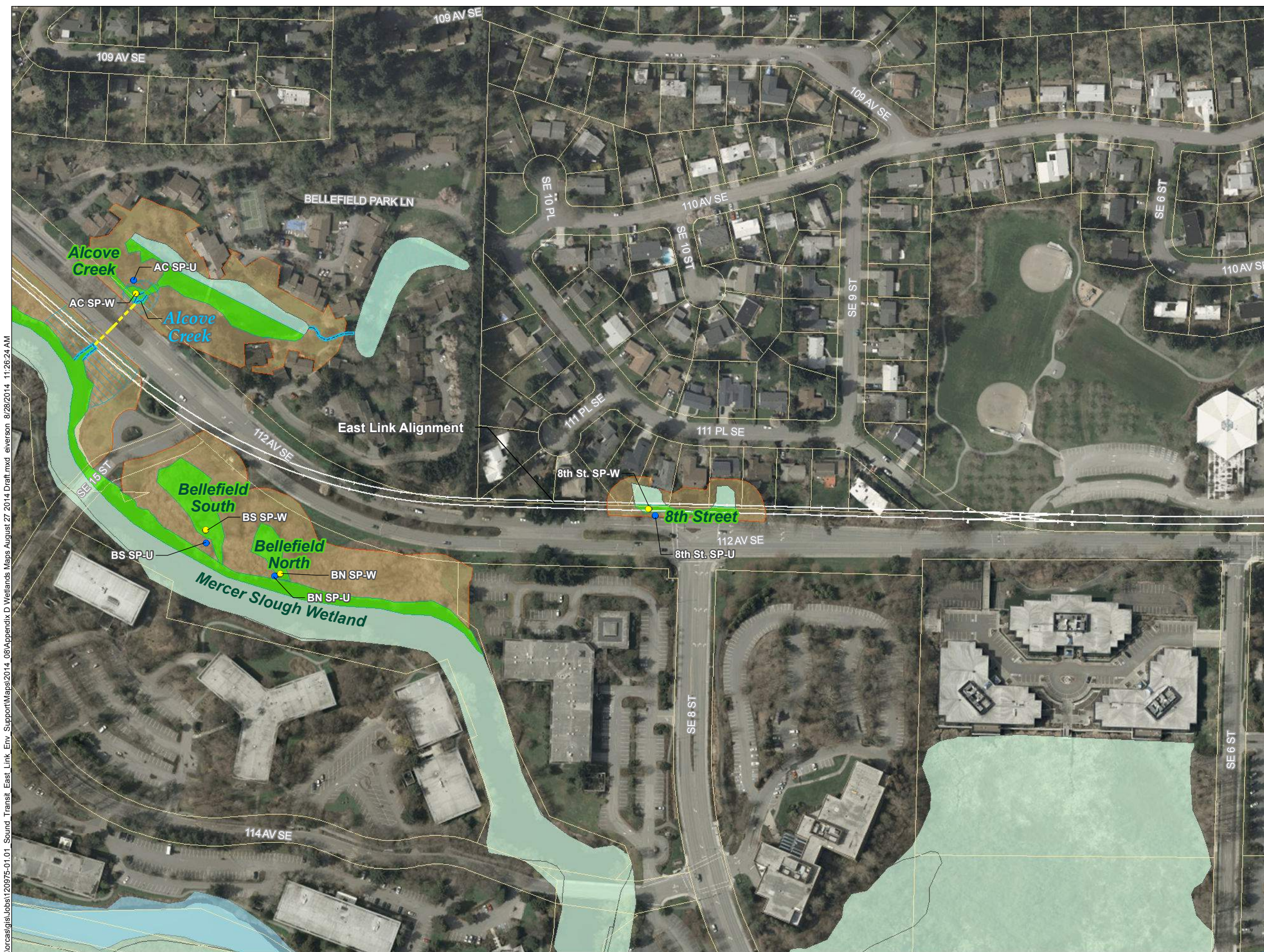
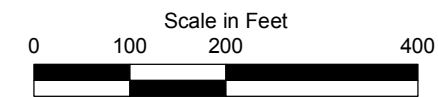

Appendix A
Wetland/Stream/Ditch Locations
Sound Transit East Link
Extension Project
Frame 6



LEGEND

- Stream Location¹
- Stream Location²
- Jurisdictional Ditch Location¹
- Culvert Location²
- Culvert Location (Estimated)³
- Mercer Slough Flow Direction
- Stream or Ditch Flow Direction
- Stream Buffers⁴
- Wetland Location¹
- Non-delineated Wetland Areas⁵
- Wetland Area Buffers⁴
- Wetlands Sample Plot
- Uplands Sample Plot
- Water Bodies (King County)
- Tax Parcels (King County)
- Proposed Light Rail Alignment

NOTES:

1. Locations determined from field survey activities carried out by Anchor QEA, LLC, in 2013.
2. City of Bellevue stream data.
3. City of Bellevue data does not include culvert information for this stream.
4. Wetland buffers and stream buffers have been modified to not extend over impervious areas or structures. Wetland and stream buffers may overlap in some areas.
5. Non-delineated areas were approximated using available aerial imagery and were not accessible due to a lack of access or agreed right-of-entry.
6. King County water body data were modified by Anchor QEA where necessary to match field-delineated ordinary high water mark (OHWM).

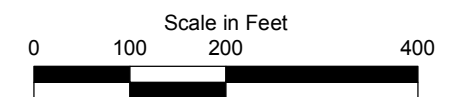

Appendix A

Wetland/Stream/Ditch Locations

Sound Transit East Link

Extension Project

Frame 7

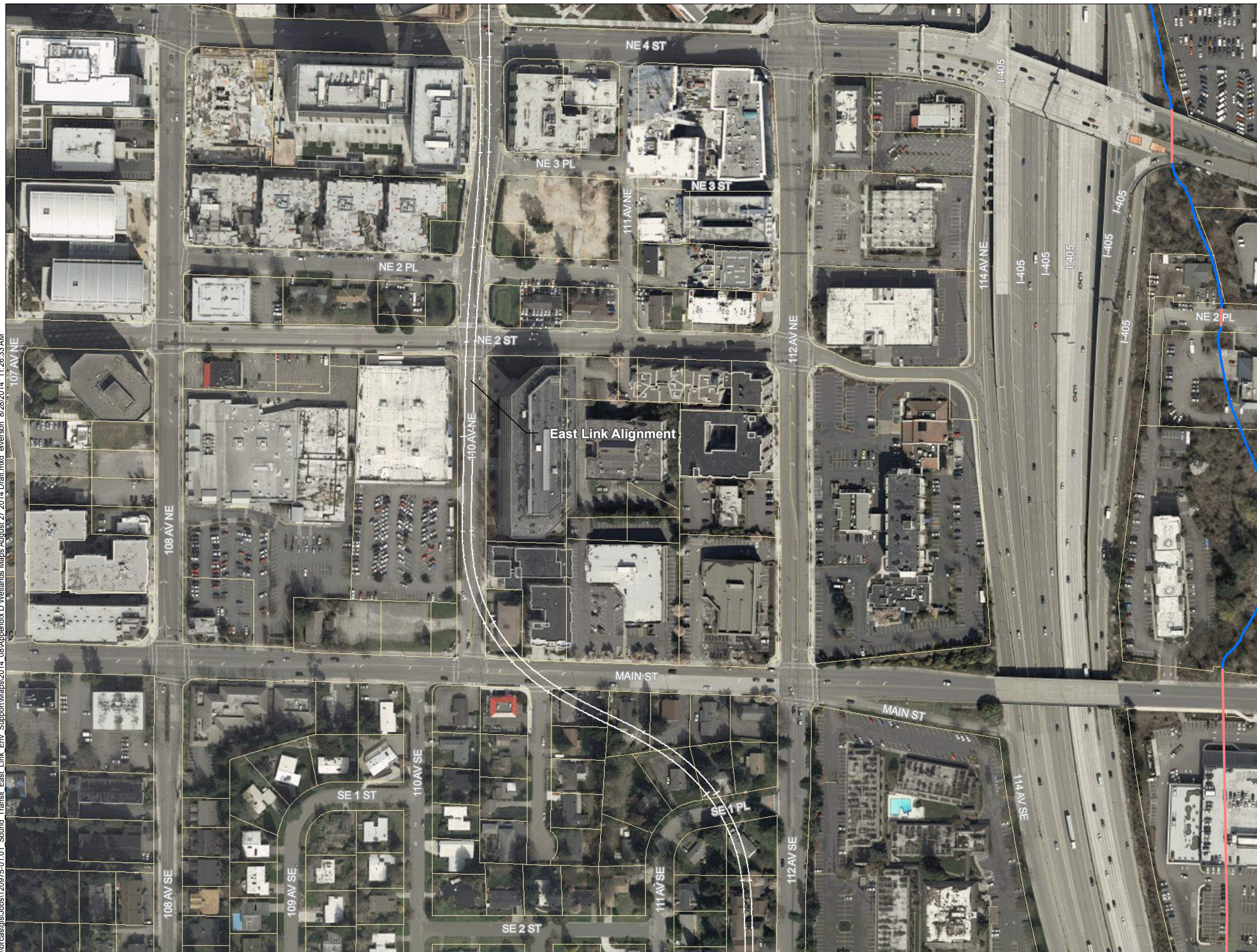

LEGEND

- Stream Location¹
- Stream Location²
- Jurisdictional Ditch Location¹
- Culvert Location²
- Culvert Location (Estimated)³
- Mercer Slough Flow Direction
- Stream or Ditch Flow Direction
- Stream Buffers⁴
- Wetland Location¹
- Non-delineated Wetland Areas⁵
- Wetland Area Buffers⁴
- Wetlands Sample Plot
- Uplands Sample Plot
- Water Bodies (King County)
- Tax Parcels (King County)
- Proposed Light Rail Alignment

NOTES:

1. Locations determined from field survey activities carried out by Anchor QEA, LLC, in 2013.
2. City of Bellevue stream data.
3. City of Bellevue data does not include culvert information for this stream.
4. Wetland buffers and stream buffers have been modified to not extend over impervious areas or structures. Wetland and stream buffers may overlap in some areas.
5. Non-delineated areas were approximated using available aerial imagery and were not accessible due to a lack of access or agreed right-of-entry.
6. King County water body data were modified by Anchor QEA where necessary to match field-delineated ordinary high water mark (OHWM).

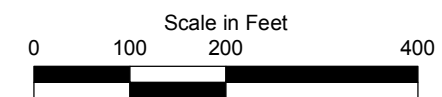

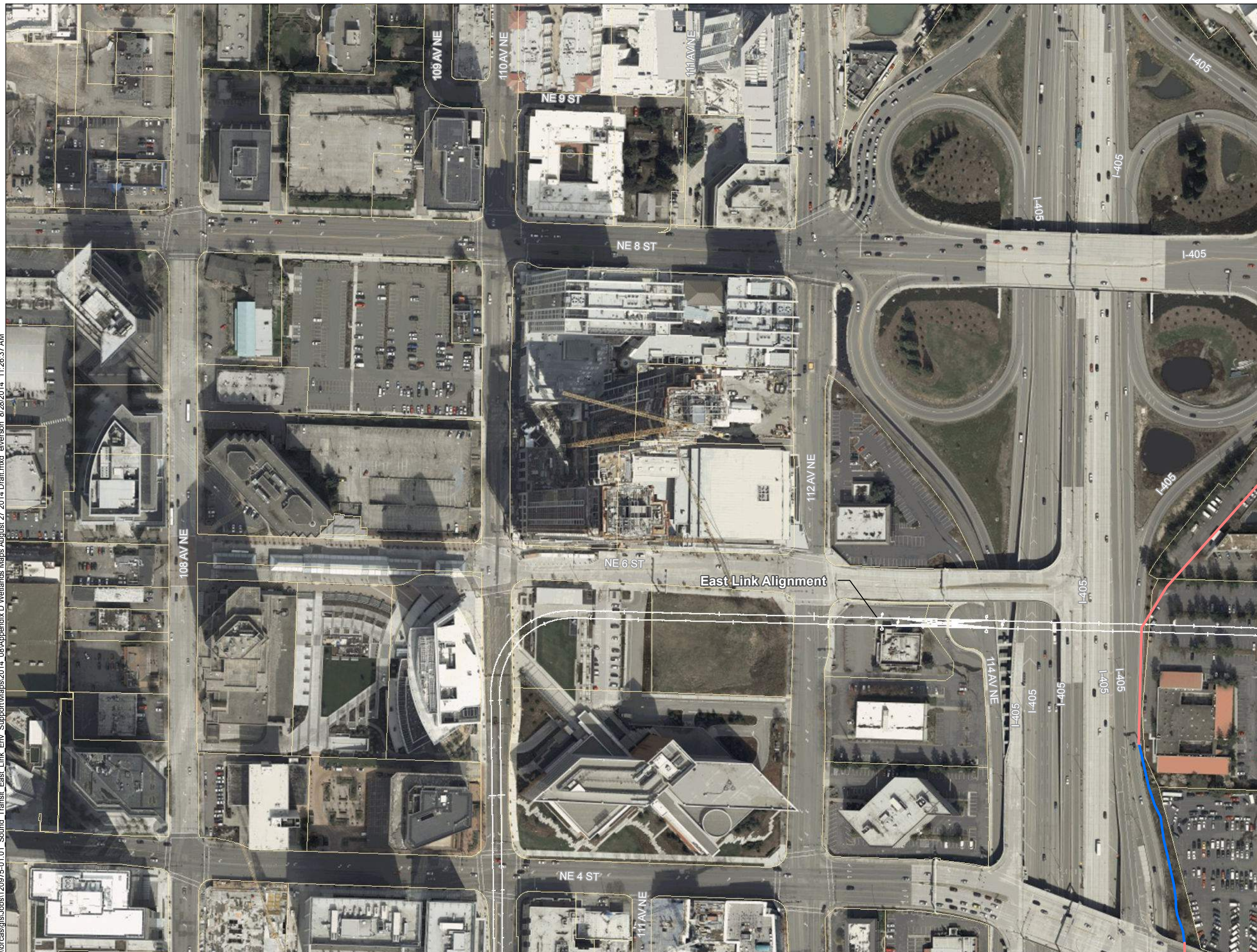

Appendix A

Wetland/Stream/Ditch Locations

Sound Transit East Link

Extension Project

Frame 8

LEGEND

- Stream Location¹
- Stream Location²
- Jurisdictional Ditch Location¹
- Culvert Location²
- Culvert Location (Estimated)³
- Mercer Slough Flow Direction
- Stream or Ditch Flow Direction
- Stream Buffers⁴
- Wetland Location¹
- Non-delineated Wetland Areas⁵
- Wetland Area Buffers⁴
- Wetlands Sample Plot
- Uplands Sample Plot
- Water Bodies (King County)
- Tax Parcels (King County)
- Proposed Light Rail Alignment

NOTES:

1. Locations determined from field survey activities carried out by Anchor QEA, LLC, in 2013.
2. City of Bellevue stream data.
3. City of Bellevue data does not include culvert information for this stream.
4. Wetland buffers and stream buffers have been modified to not extend over impervious areas or structures. Wetland and stream buffers may overlap in some areas.
5. Non-delineated areas were approximated using available aerial imagery and were not accessible due to a lack of access or agreed right-of-entry.
6. King County water body data were modified by Anchor QEA where necessary to match field-delineated ordinary high water mark (OHWM).

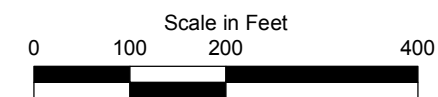

Appendix A
Wetland/Stream/Ditch Locations
Sound Transit East Link
Extension Project
Frame 9



LEGEND

- Stream Location¹
- Stream Location²
- Jurisdictional Ditch Location¹
- Culvert Location²
- Culvert Location (Estimated)³
- Mercer Slough Flow Direction
- Stream or Ditch Flow Direction
- Stream Buffers⁴
- Wetland Location¹
- Non-delineated Wetland Areas⁵
- Wetland Area Buffers⁴
- Wetlands Sample Plot
- Uplands Sample Plot
- Water Bodies (King County)
- Tax Parcels (King County)
- Proposed Light Rail Alignment

- NOTES:**
1. Locations determined from field survey activities carried out by Anchor QEA, LLC, in 2013.
 2. City of Bellevue stream data.
 3. City of Bellevue data does not include culvert information for this stream.
 4. Wetland buffers and stream buffers have been modified to not extend over impervious areas or structures. Wetland and stream buffers may overlap in some areas.
 5. Non-delineated areas were approximated using available aerial imagery and were not accessible due to a lack of access or agreed right-of-entry.
 6. King County water body data were modified by Anchor QEA where necessary to match field-delineated ordinary high water mark (OHWM).

















Scale in Feet



V:\cas\gis\Jobs\120975-01\01_Sound_Transit_East_Link_Env_Support\Maps\2014_08\Appendix D Wetlands Maps August 27 2014 Draft.mxd everson 8/28/2014 11:26:41 AM

Appendix A Wetland/Stream/Ditch Locations Sound Transit East Link Extension Project Frame 10

LEGEND

-  Stream Location¹
-  Stream Location²
-  Jurisdictional Ditch Location¹
-  Culvert Location²
-  Culvert Location (Estimated)³
-  Mercer Slough Flow Direction
-  Stream or Ditch Flow Direction
-  Stream Buffers⁴
-  Wetland Location¹
-  Non-delineated Wetland Areas⁵
-  Wetland Area Buffers⁴
-  Wetlands Sample Plot
-  Uplands Sample Plot
-  Water Bodies (King County)
-  Tax Parcels (King County)
-  Proposed Light Rail Alignment





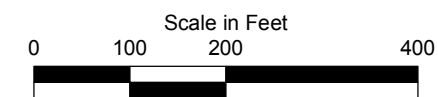











NOTES:

1. Locations determined from field survey activities carried out by Anchor QEA, LLC, in 2013.
2. City of Bellevue stream data.
3. City of Bellevue data does not include culvert information for this stream.
4. Wetland buffers and stream buffers have been modified to not extend over impervious areas or structures. Wetland and stream buffers may overlap in some areas.
5. Non-delineated areas were approximated using available aerial imagery and were not accessible due to a lack of access or agreed right-of-entry.
6. King County water body data were modified by Anchor QEA where necessary to match field-delineated ordinary high water mark (OHWM).



Appendix A
Wetland/Stream/Ditch Locations
Sound Transit East Link
Extension Project
Frame 11

LEGEND

-  Stream Location¹
-  Stream Location²
-  Jurisdictional Ditch Location¹
-  Culvert Location²
-  Culvert Location (Estimated)³
-  Mercer Slough Flow Direction
-  Stream or Ditch Flow Direction
-  Stream Buffers⁴
-  Wetland Location¹
-  Non-delineated Wetland Areas⁵
-  Wetland Area Buffers⁴
-  Wetlands Sample Plot
-  Uplands Sample Plot
-  Water Bodies (King County)
-  Tax Parcels (King County)
-  Proposed Light Rail Alignment





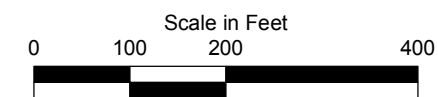











NOTES:

1. Locations determined from field survey activities carried out by Anchor QEA, LLC, in 2013.
2. City of Bellevue stream data.
3. City of Bellevue data does not include culvert information for this stream.
4. Wetland buffers and stream buffers have been modified to not extend over impervious areas or structures. Wetland and stream buffers may overlap in some areas.
5. Non-delineated areas were approximated using available aerial imagery and were not accessible due to a lack of access or agreed right-of-entry.
6. King County water body data were modified by Anchor QEA where necessary to match field-delineated ordinary high water mark (OHWM).



Appendix A Wetland/Stream/Ditch Locations Sound Transit East Link Extension Project Frame 12

LEGEND

-  Stream Location¹
-  Stream Location²
-  Jurisdictional Ditch Location¹
-  Culvert Location²
-  Culvert Location (Estimated)³
-  Mercer Slough Flow Direction
-  Stream or Ditch Flow Direction
-  Stream Buffers⁴
-  Wetland Location¹
-  Non-delineated Wetland Areas⁵
-  Wetland Area Buffers⁴
-  Wetlands Sample Plot
-  Uplands Sample Plot
-  Water Bodies (King County)
-  Tax Parcels (King County)
-  Proposed Light Rail Alignment

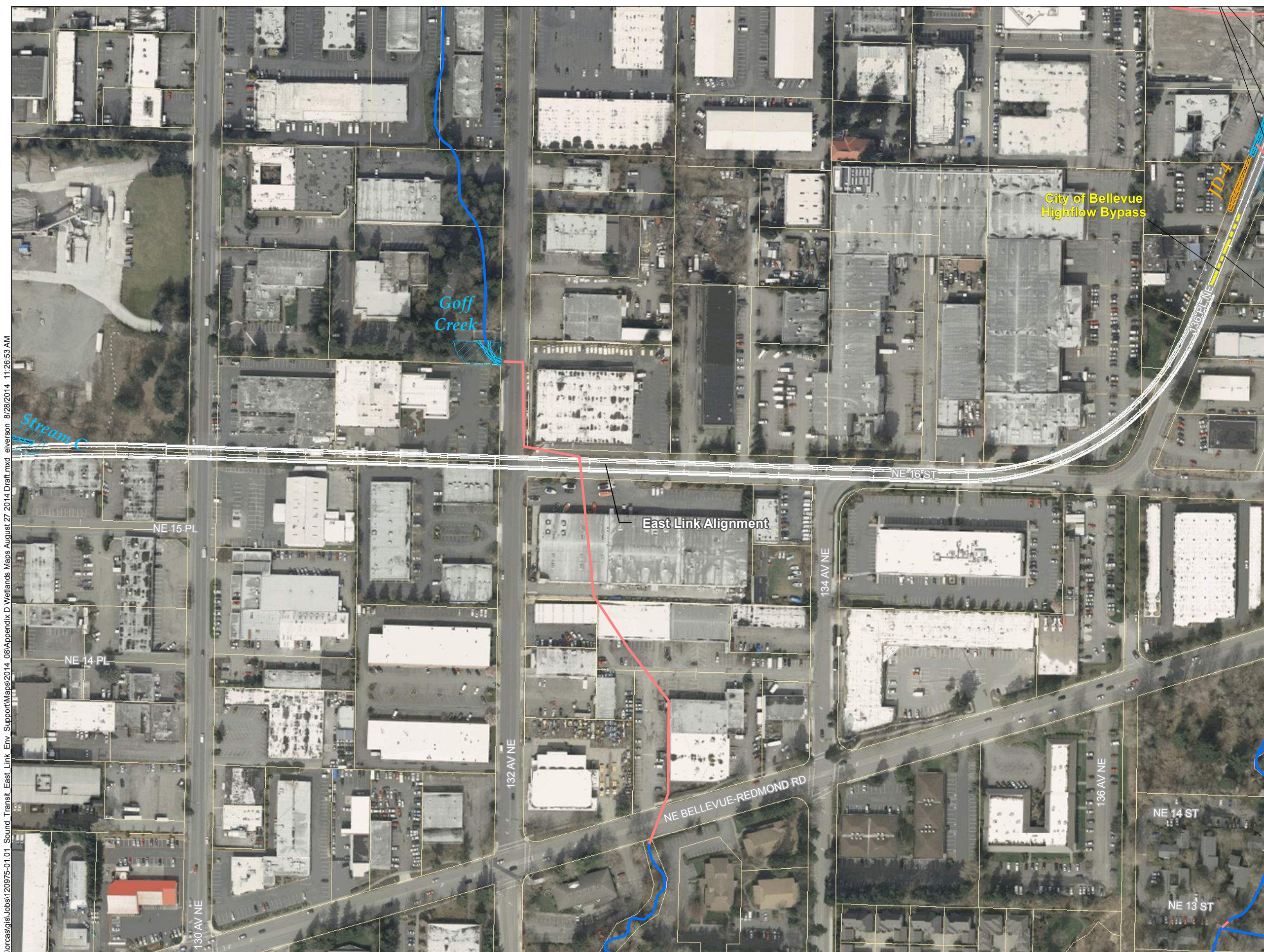
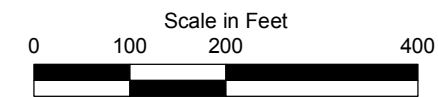

NOTES:

1. Locations determined from field survey activities carried out by Anchor QEA, LLC, in 2013.
2. City of Bellevue stream data.
3. City of Bellevue data does not include culvert information for this stream.
4. Wetland buffers and stream buffers have been modified to not extend over impervious areas or structures. Wetland and stream buffers may overlap in some areas.
5. Non-delineated areas were approximated using available aerial imagery and were not accessible due to a lack of access or agreed right-of-entry.
6. King County water body data were modified by Anchor QEA where necessary to match field-delineated ordinary high water mark (OHWM).



Appendix A
Wetland/Stream/Ditch Locations
Sound Transit East Link
Extension Project
Frame 13

LEGEND

-  Stream Location¹
-  Stream Location²
-  Jurisdictional Ditch Location¹
-  Culvert Location²
-  Culvert Location (Estimated)³
-  Mercer Slough Flow Direction
-  Stream or Ditch Flow Direction
-  Stream Buffers⁴
-  Wetland Location¹
-  Non-delineated Wetland Areas⁵
-  Wetland Area Buffers⁴
-  Wetlands Sample Plot
-  Uplands Sample Plot
-  Water Bodies (King County)
-  Tax Parcels (King County)
-  Proposed Light Rail Alignment

NOTES:



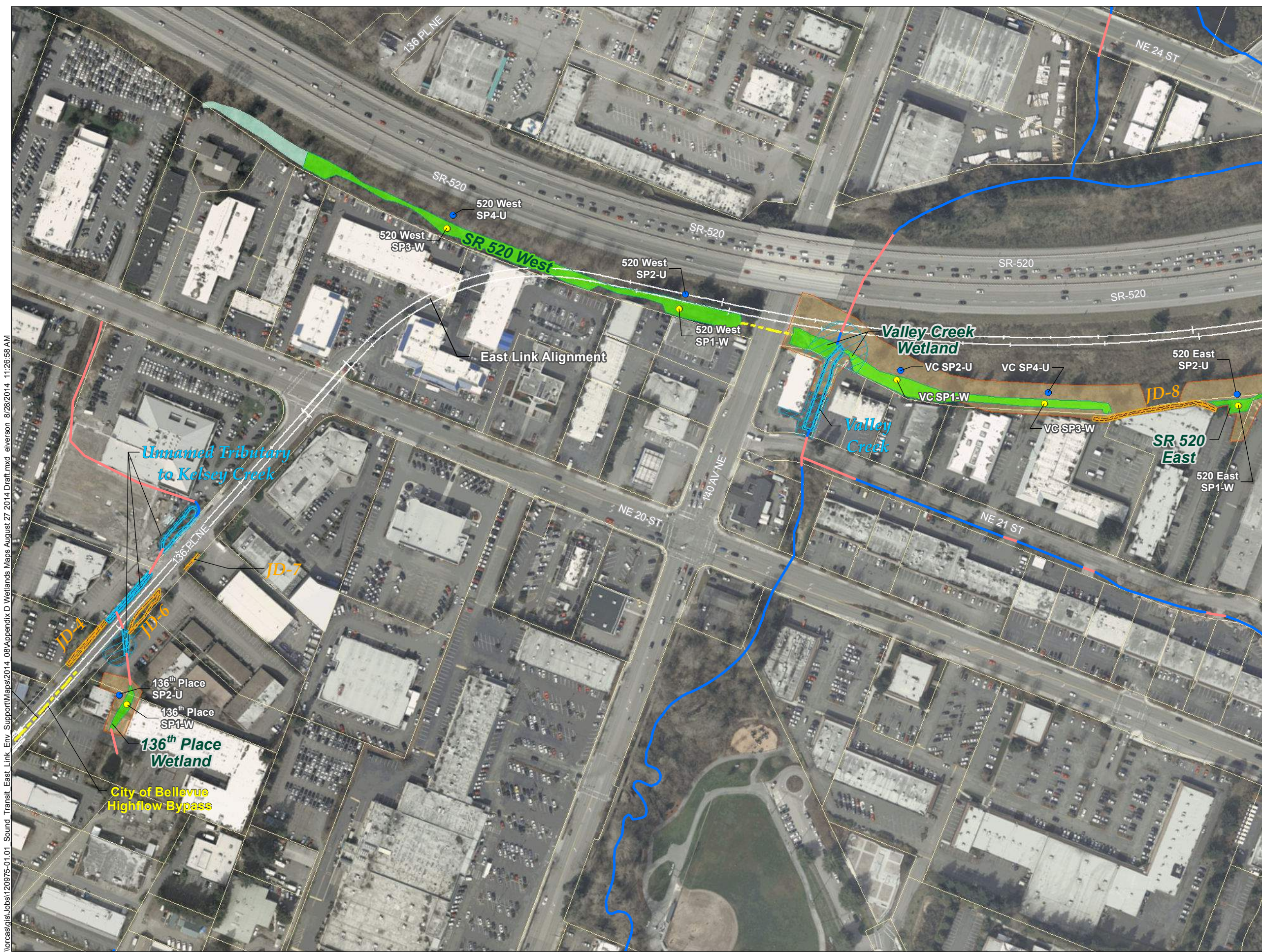
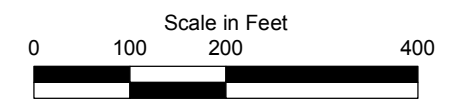













1. Locations determined from field survey activities carried out by Anchor QEA, LLC, in 2013.
2. City of Bellevue stream data.
3. City of Bellevue data does not include culvert information for this stream.
4. Wetland buffers and stream buffers have been modified to not extend over impervious areas or structures. Wetland and stream buffers may overlap in some areas.
5. Non-delineated areas were approximated using available aerial imagery and were not accessible due to a lack of access or agreed right-of-entry.
6. King County water body data were modified by Anchor QEA where necessary to match field-delineated ordinary high water mark (OHWM).



\orcasis\jobs\120975-01\01_Sound_Transit_East_Link_Support\Maps\2014_08\Appendix D Wetlands Maps August 27 2014 Draft.mxd everson 8/28/2014 11:26:58 AM

Appendix A
Wetland/Stream/Ditch Locations
Sound Transit East Link
Extension Project
Frame 14

LEGEND

-  Stream Location¹
-  Stream Location²
-  Jurisdictional Ditch Location¹
-  Culvert Location²
-  Culvert Location (Estimated)³
-  Mercer Slough Flow Direction
-  Stream or Ditch Flow Direction
-  Stream Buffers⁴
-  Wetland Location¹
-  Non-delineated Wetland Areas⁵
-  Wetland Area Buffers⁴
-  Wetlands Sample Plot
-  Uplands Sample Plot
-  Water Bodies (King County)
-  Tax Parcels (King County)
-  Proposed Light Rail Alignment

NOTES:

1. Locations determined from field survey activities carried out by Anchor QEA, LLC, in 2013.
2. City of Bellevue stream data.
3. City of Bellevue data does not include culvert information for this stream.
4. Wetland buffers and stream buffers have been modified to not extend over impervious areas or structures. Wetland and stream buffers may overlap in some areas.
5. Non-delineated areas were approximated using available aerial imagery and were not accessible due to a lack of access or agreed right-of-entry.
6. King County water body data were modified by Anchor QEA where necessary to match field-delineated ordinary high water mark (OHWM).

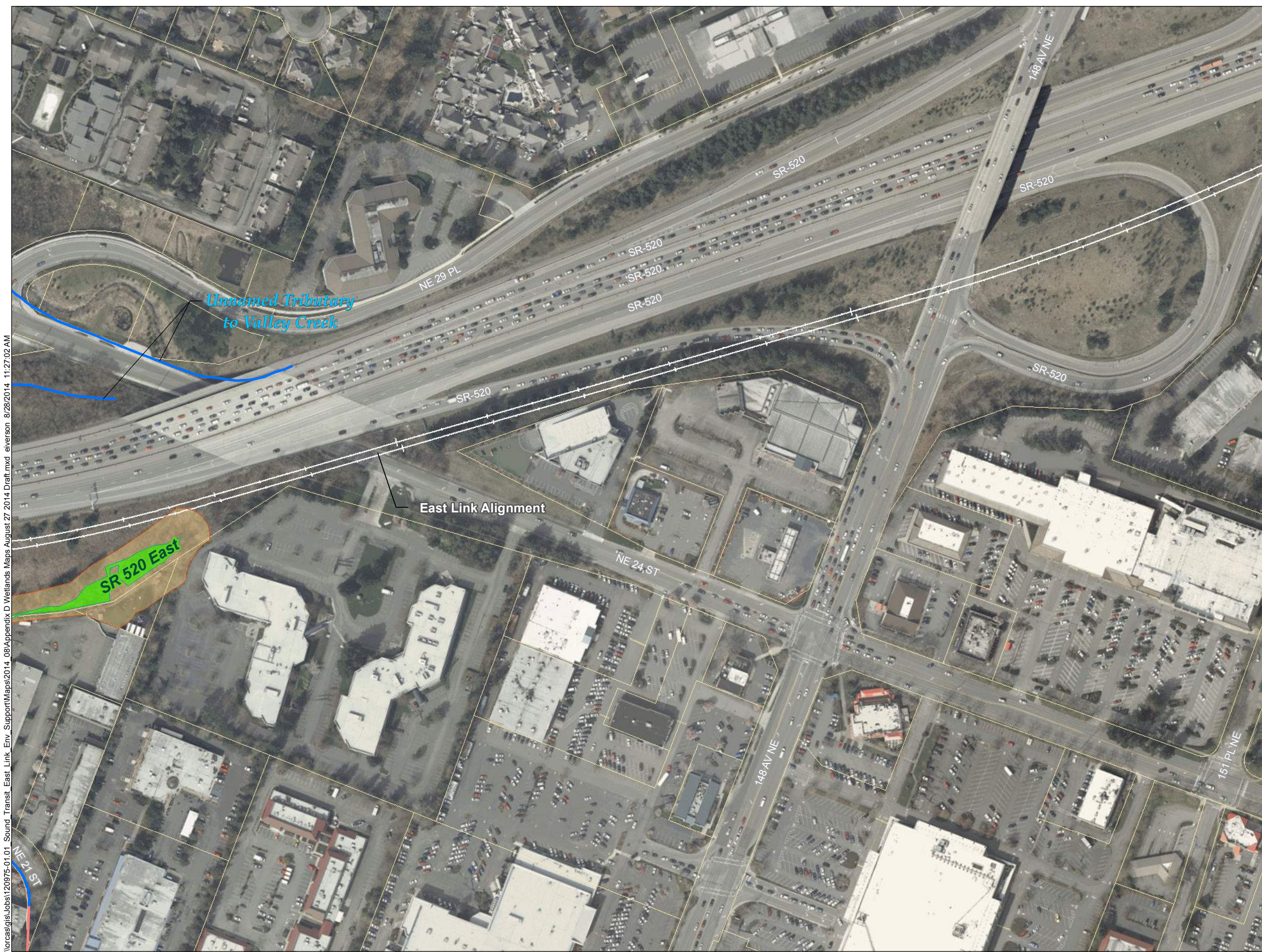
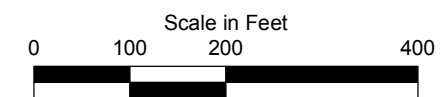

V:\cas\gis\Jobs\120975-01\01_Sound_Transit_East_Link_Support\Maps\2014_08\Appendix A Wetlands Maps August 27 2014 Draft.mxd eiverson 8/28/2014 11:27:02 AM

Appendix B

Wetland, Stream, and Buffer Impacts

NAME	PERMANENT IMPACTS	TEMPORARY IMPACTS	VEGETATION CONVERSION IMPACTS
MERCER SLOUGH WETLAND	0.17 ACRE	0.22 ACRE	0.32 ACRE
MERCER SLOUGH WETLAND BUFFER	4.10 ACRES	4.43 ACRES	NA



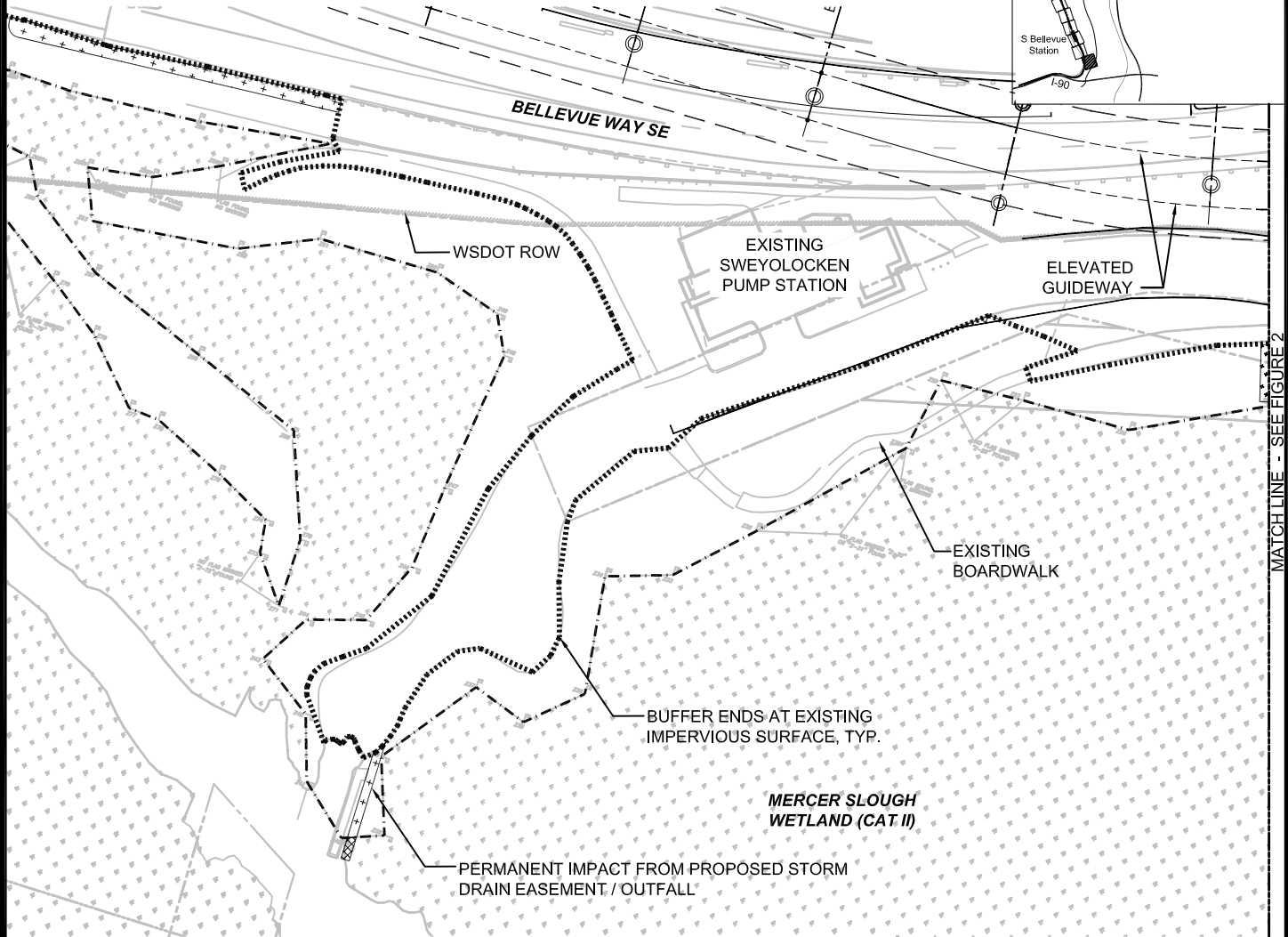
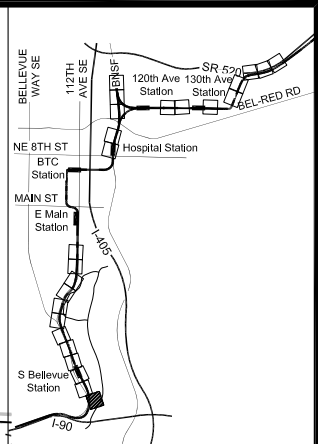

NOTES:

- VALUES REPRESENT IMPACTS TO ENTIRE CRITICAL AREA, NOT JUST AREA SHOWN ON THIS SHEET.
- OVERLAPPING WETLAND AND STREAM BUFFER AREAS ARE SHOWN AS WETLAND BUFFERS. STREAM BUFFER IS ONLY SHOWN WHERE THERE IS NO WETLAND BUFFER OVERLAP.
- SHORELINE CRITICAL AREA BUFFERS ARE ENCOMPASSED WITHIN STREAM AND WETLAND BUFFER AREAS.

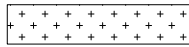
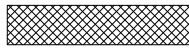

MATCH LINE - SEE FIGURE 2

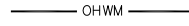
LEGEND

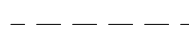
-  PERMANENT BUFFER IMPACT
-  PERMANENT WETLAND IMPACT
-  EXISTING WETLAND
-  EXISTING WETLAND BUFFER
-  OHWM
-  ORDINARY HIGH WATER MARK
-  VEGETATION CLEAR ZONE (VCZ)

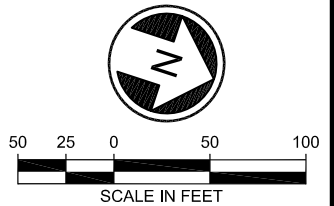

05/21/15 | 1:50 PM | JWLONG J:\65229\CADD\5001\DRAWINGS\ARCH\CRITICAL AREAS REPORT\IMPACTS\IES204\85-CARB.DWG



EAST LINK EXTENSION
SOUTH BELLEVUE TO OVERLAKE TRANSIT CENTER
 APPENDIX B
 FIGURE 1
 WETLAND, STREAM, AND BUFFER IMPACTS

NAME	PERMANENT IMPACTS	TEMPORARY IMPACTS	VEGETATION CONVERSION IMPACTS
MERCER SLOUGH WETLAND	0.17 ACRE	0.22 ACRE	0.32 ACRE
MERCER SLOUGH WETLAND BUFFER	4.10 ACRES	4.43 ACRES	NA

NOTES:



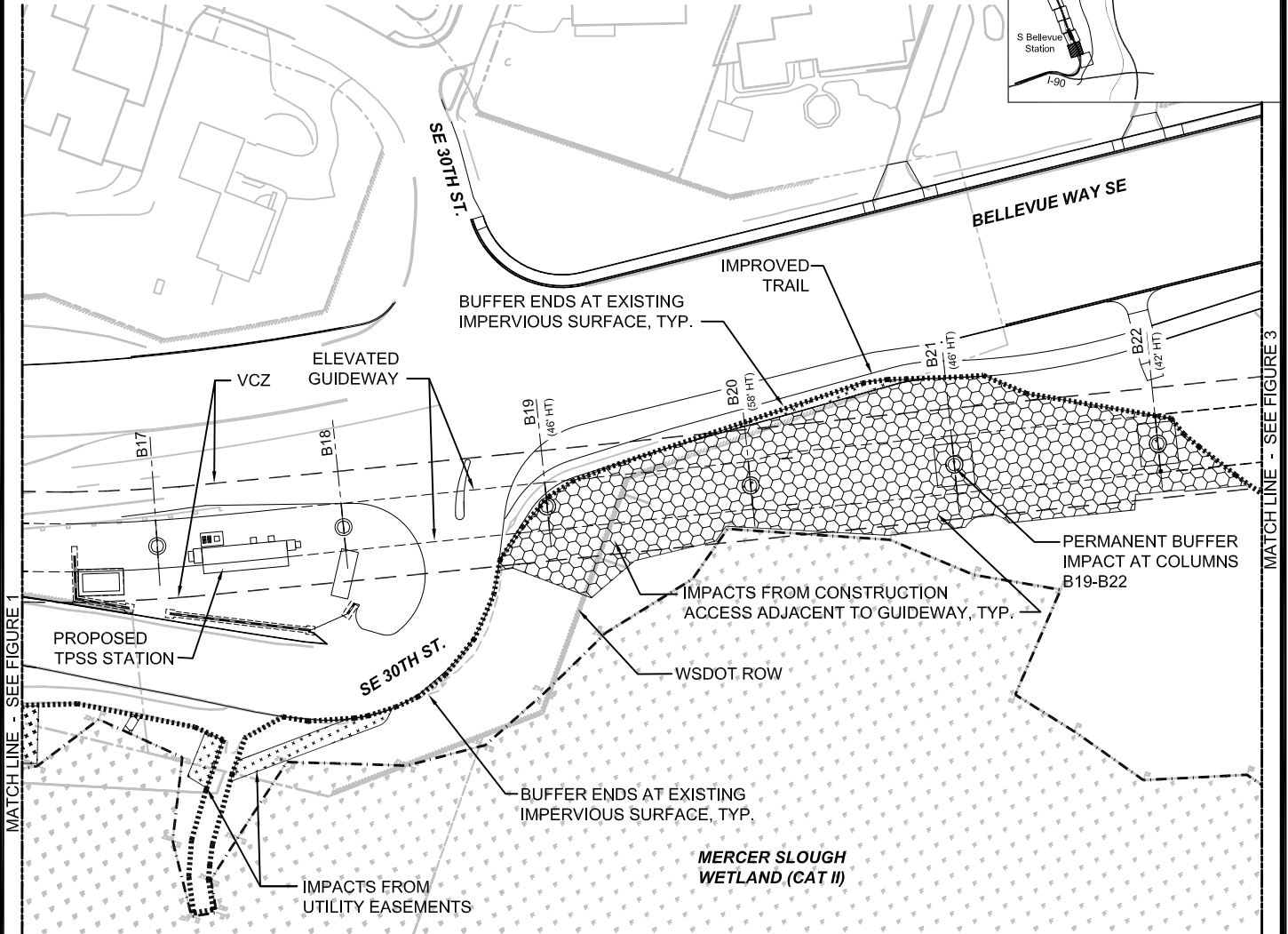
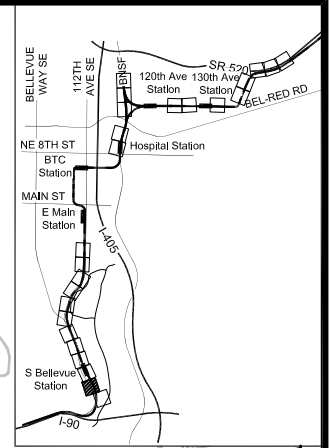

- VALUES REPRESENT IMPACTS TO ENTIRE CRITICAL AREA, NOT JUST AREA SHOWN ON THIS SHEET.
- OVERLAPPING WETLAND AND STREAM BUFFER AREAS ARE SHOWN AS WETLAND BUFFERS. STREAM BUFFER IS ONLY SHOWN WHERE THERE IS NO WETLAND BUFFER OVERLAP.
- GUIDEWAY CLEARANCE AT COLUMNS NEAR CRITICAL AREAS IS LISTED AS "XX' HT"
- SHORELINE CRITICAL AREA BUFFERS ARE ENCOMPASSED WITHIN STREAM AND WETLAND BUFFER AREAS.

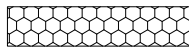
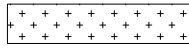

MATCH LINE - SEE FIGURE 1

MATCH LINE - SEE FIGURE 3

LEGEND

-  TEMPORARY BUFFER IMPACT
-  PERMANENT BUFFER IMPACT
-  EXISTING WETLAND
-  EXISTING WETLAND BUFFER
-  VEGETATION CLEAR ZONE (VCZ)

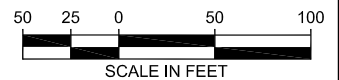

05/21/15 | 1:52 PM | JMWLONG
J:\65229\CADD\5001\DRAWINGS\ARCH\CRITICAL AREAS REPORT\IMPACTS\IE320-L85-CARB.DWG



EAST LINK EXTENSION
SOUTH BELLEVUE TO OVERLAKE TRANSIT CENTER
 APPENDIX B
 FIGURE 2
 WETLAND, STREAM, AND BUFFER IMPACTS

NAME	PERMANENT IMPACTS	TEMPORARY IMPACTS
MERCER SLOUGH WETLAND	0.17 ACRE	0.22 ACRE
MERCER SLOUGH WETLAND BUFFER	4.10 ACRES	4.43 ACRES

NOTES:

- VALUES REPRESENT IMPACTS TO ENTIRE CRITICAL AREA, NOT JUST AREA SHOWN ON THIS SHEET.
- OVERLAPPING WETLAND AND STREAM BUFFER AREAS ARE SHOWN AS WETLAND BUFFERS. STREAM BUFFER IS ONLY SHOWN WHERE THERE IS NO WETLAND BUFFER OVERLAP.
- GUIDEWAY CLEARANCE AT COLUMNS NEAR CRITICAL AREAS IS LISTED AS "XX' HT"
- SHORELINE CRITICAL AREA BUFFERS ARE ENCOMPASSED WITHIN STREAM AND WETLAND BUFFER AREAS.

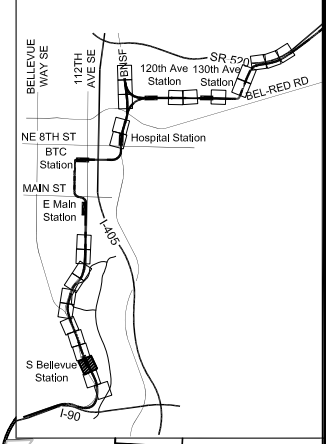
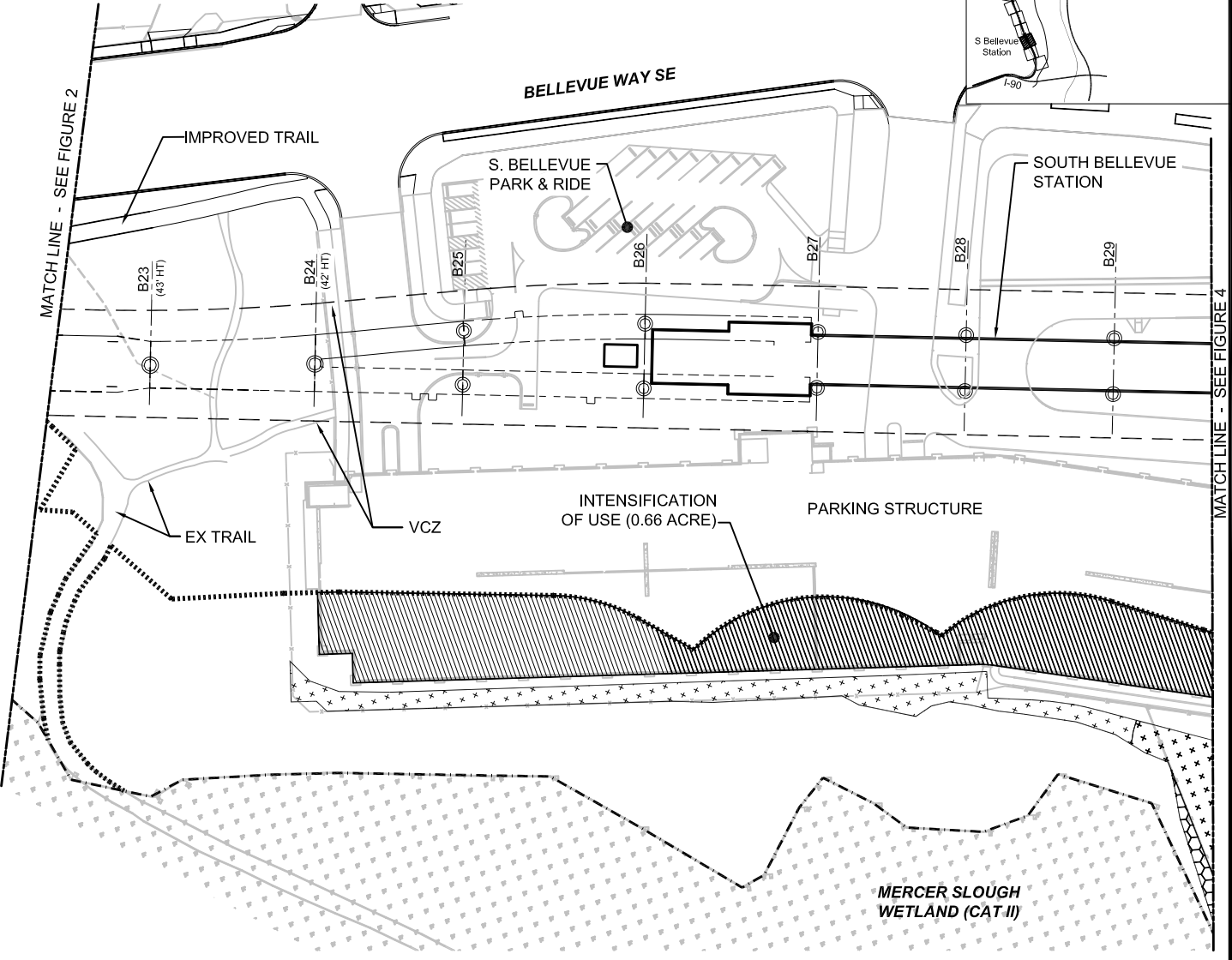

LEGEND

- TEMPORARY BUFFER IMPACT
- PERMANENT BUFFER IMPACT
- EXISTING WETLAND
- EXISTING WETLAND BUFFER
- VEGETATION CLEAR ZONE (VCZ)

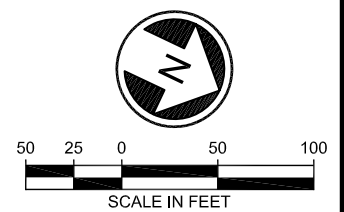

04/29/15 | 1:55 PM | JLOGAN J:\65229\CADD\5001\DRAWINGS\ARCH\CRITICAL AREAS REPORT\IMPACTS\IE320-L85-CARB.DWG

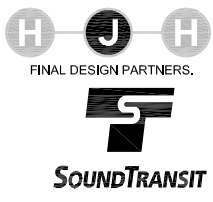

**EAST LINK EXTENSION
SOUTH BELLEVUE TO OVERLAKE TRANSIT CENTER
APPENDIX B
FIGURE 3
WETLAND, STREAM, AND BUFFER IMPACTS**

NAME	PERMANENT IMPACTS	TEMPORARY IMPACTS	VEGETATION CONVERSION IMPACTS
MERCER SLOUGH WETLAND	0.17 ACRE	0.22 ACRE	0.32 ACRE
MERCER SLOUGH WETLAND BUFFER	4.10 ACRES	4.43 ACRES	NA

NOTES:

1. VALUES REPRESENT IMPACTS TO ENTIRE CRITICAL AREA, NOT JUST AREA SHOWN ON THIS SHEET.
2. OVERLAPPING WETLAND AND STREAM BUFFER AREAS ARE SHOWN AS WETLAND BUFFERS. STREAM BUFFER IS ONLY SHOWN WHERE THERE IS NO WETLAND BUFFER OVERLAP.
3. GUIDEWAY CLEARANCE AT COLUMNS NEAR CRITICAL AREAS IS LISTED AS "XX' HT"
4. SHORELINE CRITICAL AREA BUFFERS ARE ENCOMPASSED WITHIN STREAM AND WETLAND BUFFER AREAS.

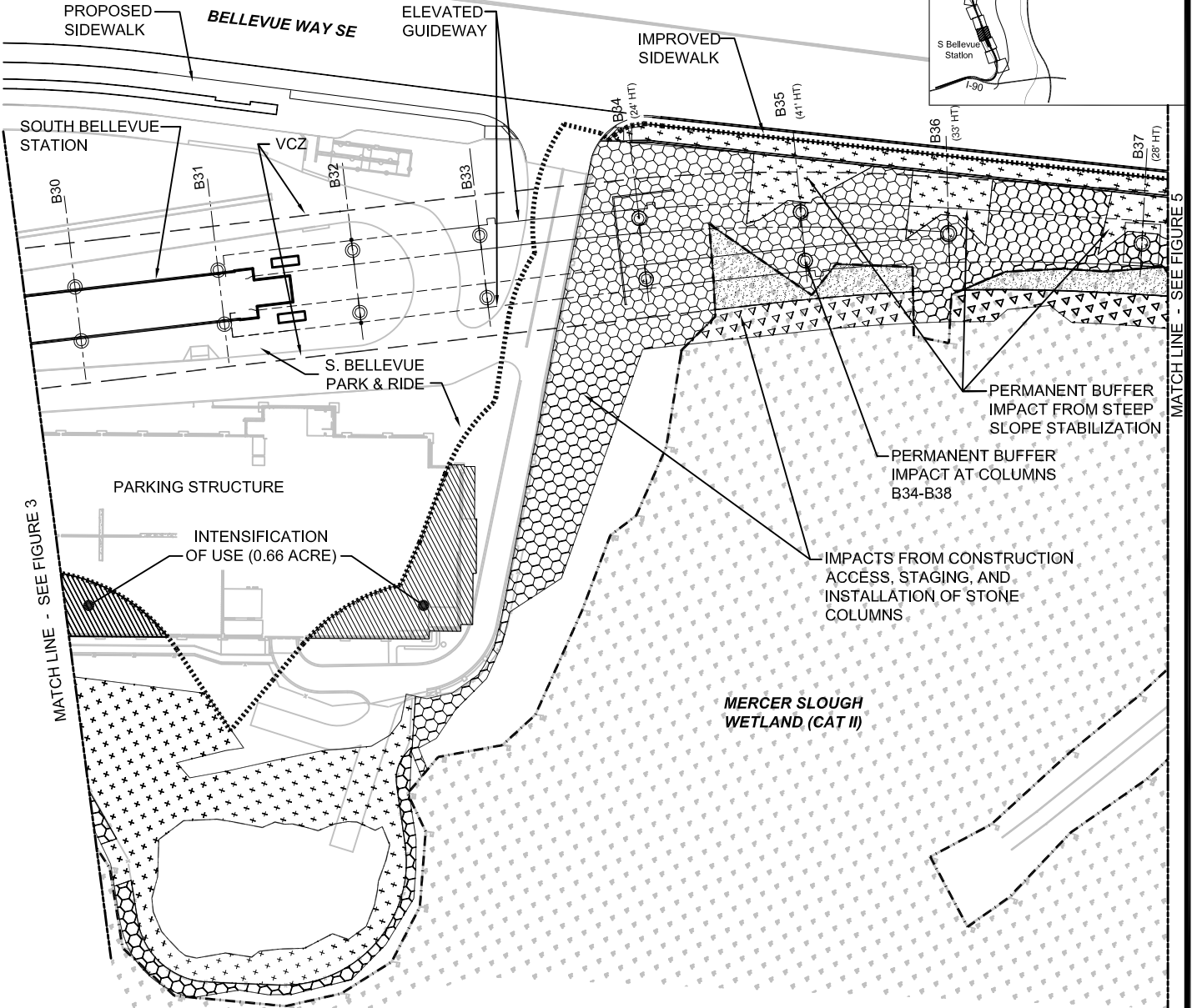
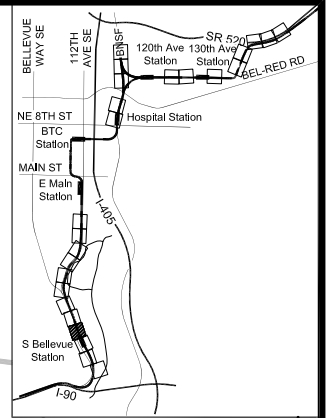

LEGEND

- TEMPORARY BUFFER IMPACT
- TEMPORARY WETLAND IMPACT
- PERMANENT BUFFER IMPACT
- WETLAND VEGETATION CONVERSION IMPACT
- EXISTING WETLAND
- EXISTING WETLAND BUFFER
- VEGETATION CLEAR ZONE (VCZ)

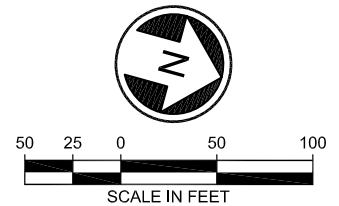

05/21/15 | 1:53 PM | JWL/ONG J:\65229\CADD\5001\DRAWINGS\ARCH\CRITICAL AREAS REPORT\IMPACTS\ES20-L85-CARB.DWG



**EAST LINK EXTENSION
SOUTH BELLEVUE TO OVERLAKE TRANSIT CENTER
APPENDIX B
FIGURE 4
WETLAND, STREAM, AND BUFFER IMPACTS**

NAME	PERMANENT IMPACTS	TEMPORARY IMPACTS	VEGETATION CONVERSION IMPACTS
MERCER SLOUGH WETLAND	0.17 ^a ACRE	0.22 ACRE	0.32 ACRE
MERCER SLOUGH WETLAND BUFFER	4.10 ACRES	4.43 ACRES	NA

a. ACREAGE INCLUDES .02 ACRE FOR THE BOARDWALK PIN PILES, WHICH IS NOT REGULATED BY THE ARMY CORPS OF ENGINEERS.

NOTES:

- VALUES REPRESENT IMPACTS TO ENTIRE CRITICAL AREA, NOT JUST AREA SHOWN ON THIS SHEET.
- OVERLAPPING WETLAND AND STREAM BUFFER AREAS ARE SHOWN AS WETLAND BUFFERS. STREAM BUFFER IS ONLY SHOWN WHERE THERE IS NO WETLAND BUFFER OVERLAP.
- GUIDEWAY CLEARANCE AT COLUMNS NEAR CRITICAL AREAS IS LISTED AS "XX' HT"
- SHORELINE CRITICAL AREA BUFFERS ARE ENCOMPASSED WITHIN STREAM AND WETLAND BUFFER AREAS.

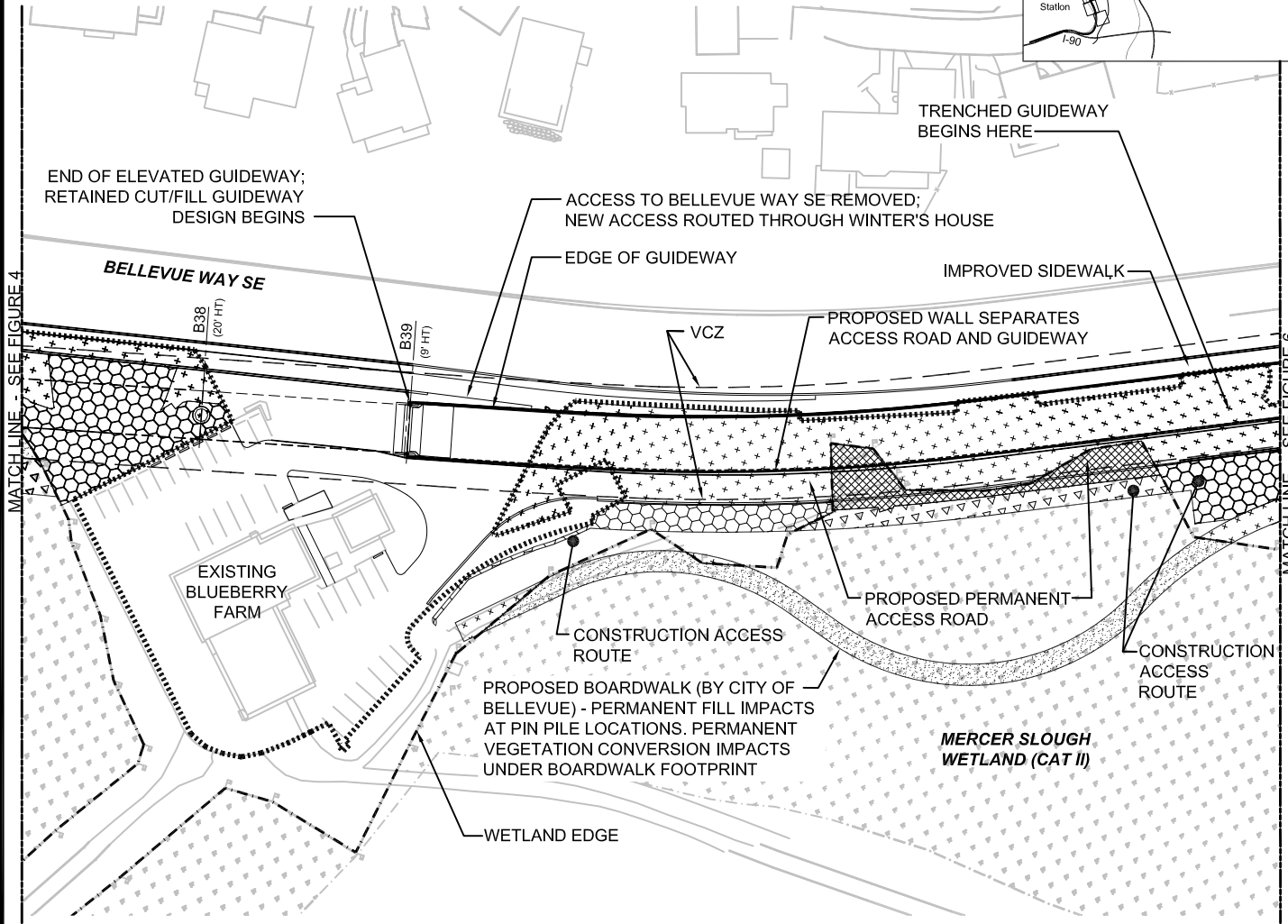
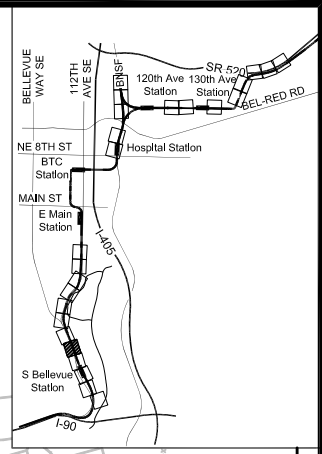

LEGEND

- TEMPORARY BUFFER IMPACT
- TEMPORARY WETLAND IMPACT
- PERMANENT BUFFER IMPACT
- PERMANENT WETLAND IMPACT
- WETLAND VEGETATION CONVERSION IMPACT
- EXISTING WETLAND
- EXISTING WETLAND BUFFER
- VEGETATION CLEAR ZONE (VCZ)

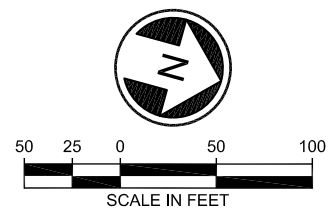

05/21/15 | 1:54 PM | JMWLONG J:\65229\CADD\5001\DRAWINGS\ARCH\CRITICAL AREAS REPORT\IMPACTS\IE3204-85-CARB.DWG



**EAST LINK EXTENSION
SOUTH BELLEVUE TO OVERLAKE TRANSIT CENTER
APPENDIX B
FIGURE 5
WETLAND, STREAM, AND BUFFER IMPACTS**

NAME	PERMANENT IMPACTS	TEMPORARY IMPACTS	VEGETATION CONVERSION IMPACTS
MERCER SLOUGH WETLAND	0.17 ^{a,b} ACRE	0.22 ACRE	0.32 ACRE
MERCER SLOUGH WETLAND BUFFER	4.10 ACRES	4.43 ACRES	NA

a. ACREAGE INCLUDES .02 ACRE FOR THE BOARDWALK PIN PILES, WHICH IS NOT REGULATED BY THE ARMY CORPS OF ENGINEERS.

b. ACREAGE DOES NOT INCLUDE 236 SF OF EXCAVATION TO CONSTRUCT A DRAINAGE SWALE EAST OF THE WINTERS HOUSE (SEE CALLOUT BELOW).

NOTES:

- VALUES REPRESENT IMPACTS TO ENTIRE CRITICAL AREA, NOT JUST AREA SHOWN ON THIS SHEET.
- OVERLAPPING WETLAND AND STREAM BUFFER AREAS ARE SHOWN AS WETLAND BUFFERS. STREAM BUFFER IS ONLY SHOWN WHERE THERE IS NO WETLAND BUFFER OVERLAP.
- SHORELINE CRITICAL AREA BUFFERS ARE ENCOMPASSED WITHIN STREAM AND WETLAND BUFFER AREAS.

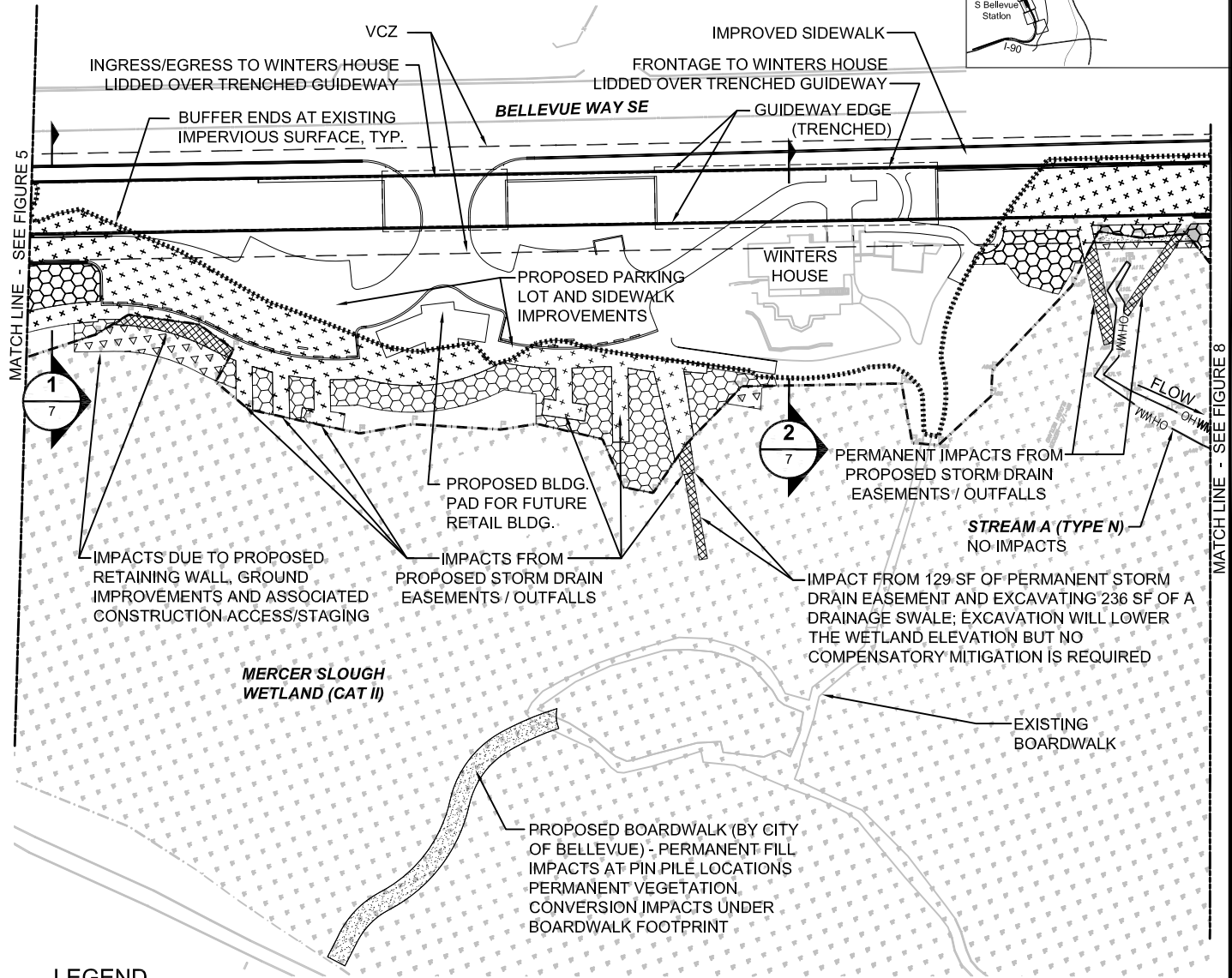
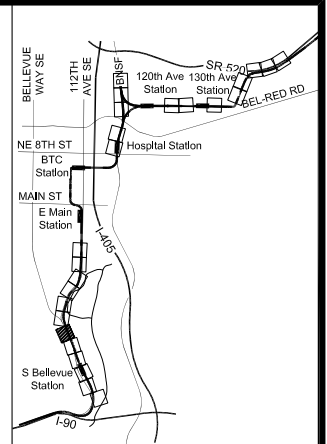

LEGEND

	TEMPORARY BUFFER IMPACT		WETLAND VEGETATION CONVERSION IMPACT
	TEMPORARY WETLAND IMPACT		EXISTING WETLAND
	PERMANENT BUFFER IMPACT		EXISTING WETLAND BUFFER
	PERMANENT WETLAND IMPACT		ORDINARY HIGH WATER MARK
			VEGETATION CLEAR ZONE (VCZ)

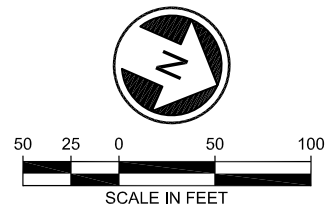

05/21/15 | 1:56 PM | JIM LONG
J:\65229\CADD\5001\DRAWINGS\ARCH\CRITICAL AREAS REPORT\IMPACTS\IE520L-B5-CARB.DWG



EAST LINK EXTENSION
SOUTH BELLEVUE TO OVERLAKE TRANSIT CENTER
 APPENDIX B
 FIGURE 6
 WETLAND, STREAM, AND BUFFER IMPACTS

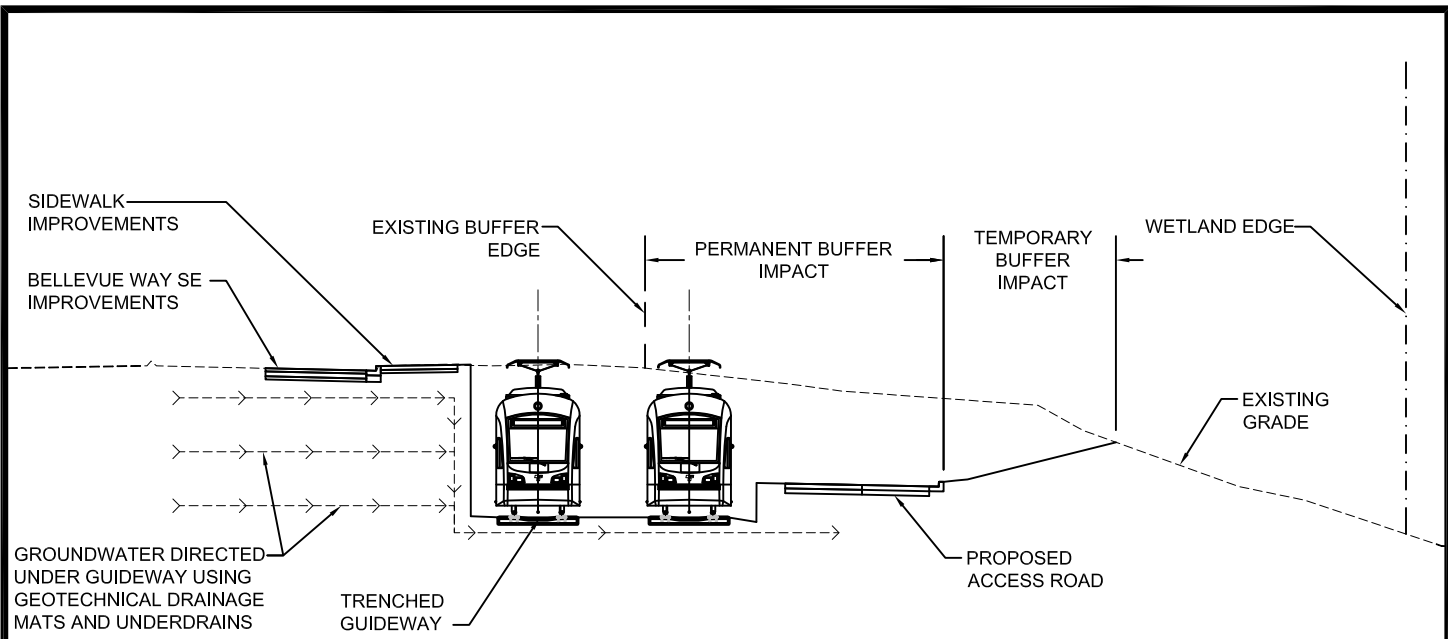

NOTE: SEE FIGURE 6 FOR PLAN VIEW SHOWING IMPACT AREA.

ACCESS ROAD BETWEEN WINTERS HOUSE AND BLUEBERRY FARM - SECTION 1

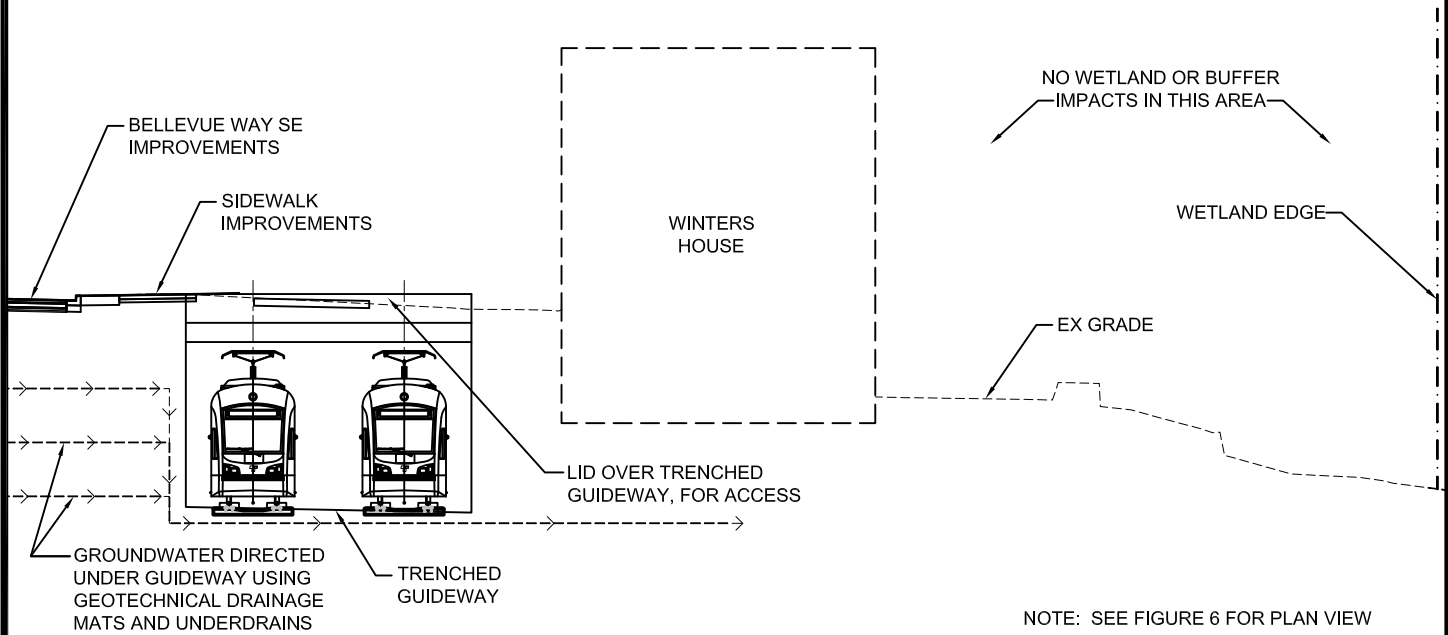

NOTE: SEE FIGURE 6 FOR PLAN VIEW

WINTERS HOUSE - SECTION 2

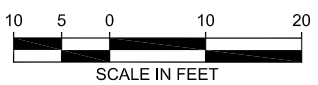

05/05/15 | 1:16 PM | JLOGAN | J:\55229\CADD\5001\DRAWINGS\ARCH\CRITICAL AREAS REPORT\IMPACTS\IE20-LB5-CARB-7.DWG



NAME	PERMANENT IMPACTS	TEMPORARY IMPACTS	VEGETATION CONVERSION IMPACTS
MERCER SLOUGH WETLAND	0.17 ACRE	0.22 ACRE	0.32 ACRE
MERCER SLOUGH WETLAND BUFFER	4.10 ACRES	4.43 ACRES	NA
WYE CREEK	420 SF	110 SF	NA
WYE CREEK BUFFER	0.09 ACRE	0.11 ACRE	NA

NOTES:

- VALUES REPRESENT IMPACTS TO ENTIRE CRITICAL AREA, NOT JUST AREA SHOWN ON THIS SHEET.
- OVERLAPPING WETLAND AND STREAM BUFFER AREAS ARE SHOWN AS WETLAND BUFFERS. STREAM BUFFER IS ONLY SHOWN WHERE THERE IS NO WETLAND BUFFER OVERLAP.
- SHORELINE CRITICAL AREA BUFFERS ARE ENCOMPASSED WITHIN STREAM AND WETLAND BUFFER AREAS.

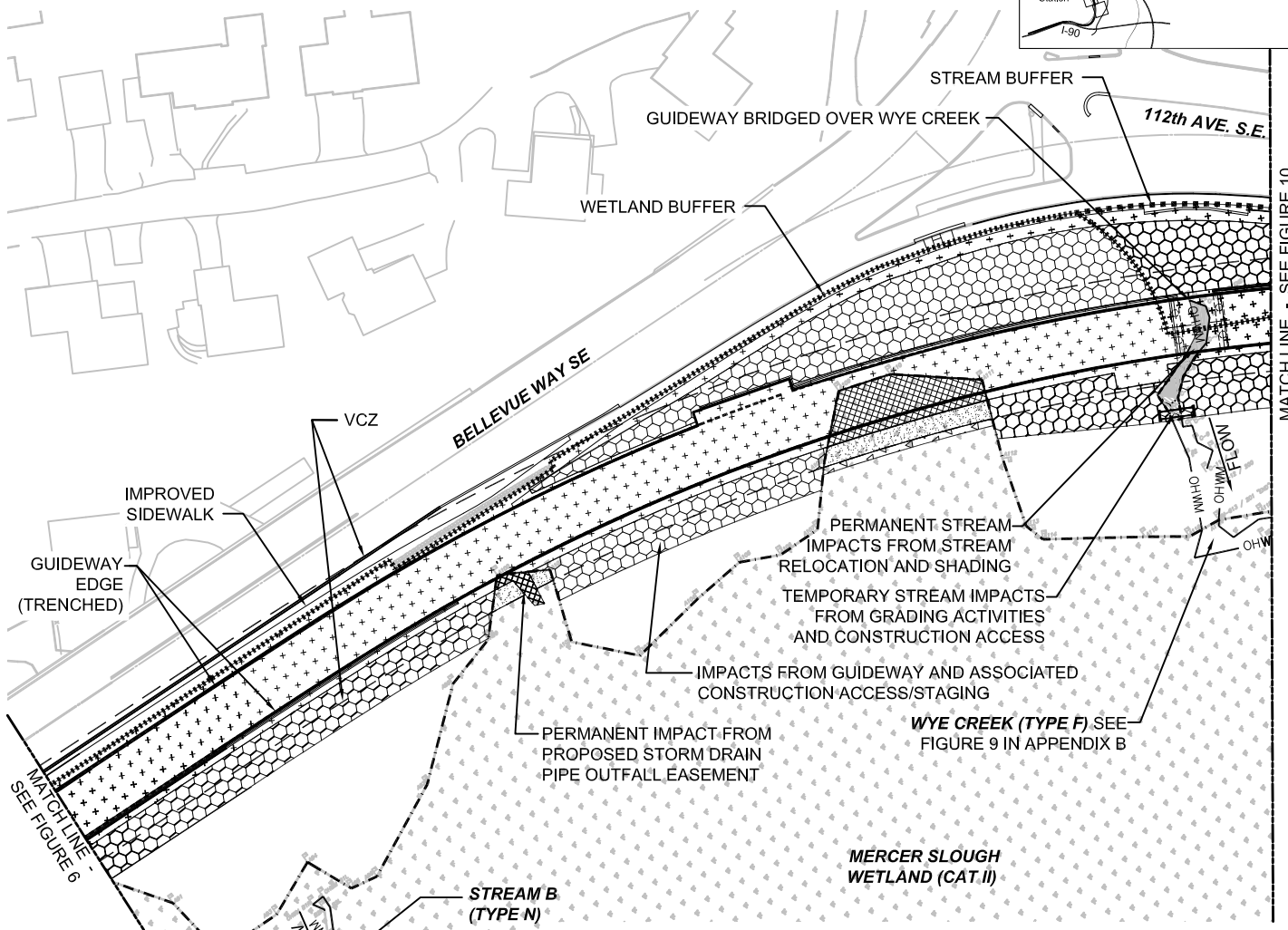
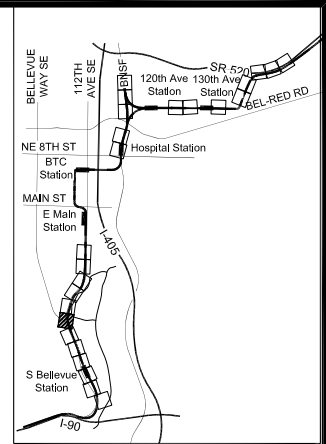

MATCH LINE - SEE FIGURE 10

LEGEND

	TEMPORARY BUFFER IMPACT		WETLAND VEGETATION CONVERSION IMPACT
	TEMPORARY WETLAND IMPACT		EXISTING WETLAND
	PERMANENT BUFFER IMPACT		EXISTING WETLAND BUFFER
	PERMANENT WETLAND IMPACT		EXISTING STREAM BUFFER
	PERMANENT STREAM IMPACT (SHADING AND STREAM RELOCATION)		ORDINARY HIGH WATER MARK
			VEGETATION CLEAR ZONE (VCZ)

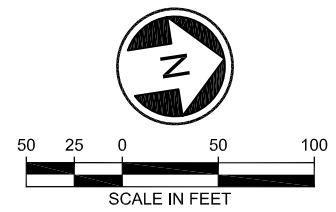

06/18/15 | 12:20 PM | JLOGAN | J:\65229\CADD\5001\DRAWINGS\ARCH\CRITICAL AREAS REPORT\IMPACTS\IES20-LB5-CARB.DWG



EAST LINK EXTENSION
SOUTH BELLEVUE TO OVERLAKE TRANSIT CENTER
 APPENDIX B
 FIGURE 8
 WETLAND, STREAM, AND BUFFER IMPACTS

94 SF OF WYE CREEK DAYLIGHTED BY SHORTENING EXISTING CULVERTS; 62 SF IS NOT UNDER BRIDGE AND IS CREDITED TOWARD RESTORATION

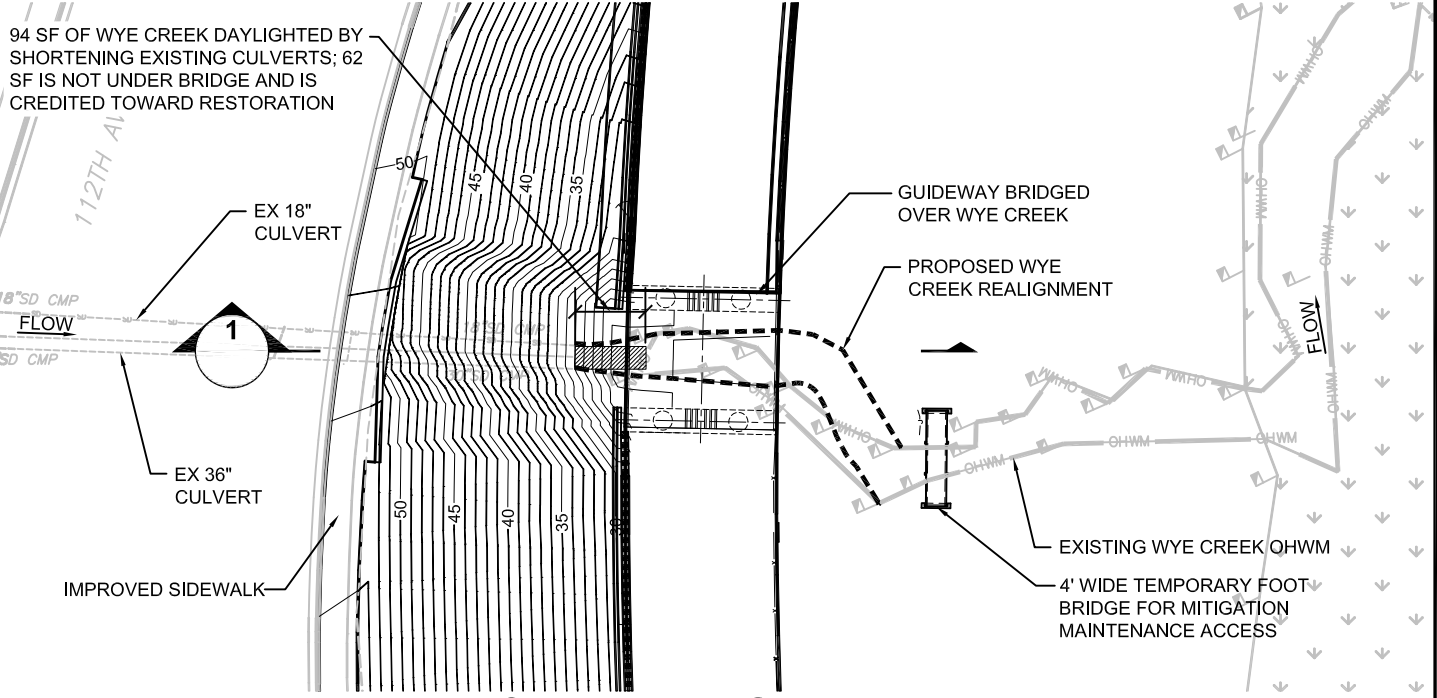

WYE CREEK BRIDGE - PLAN

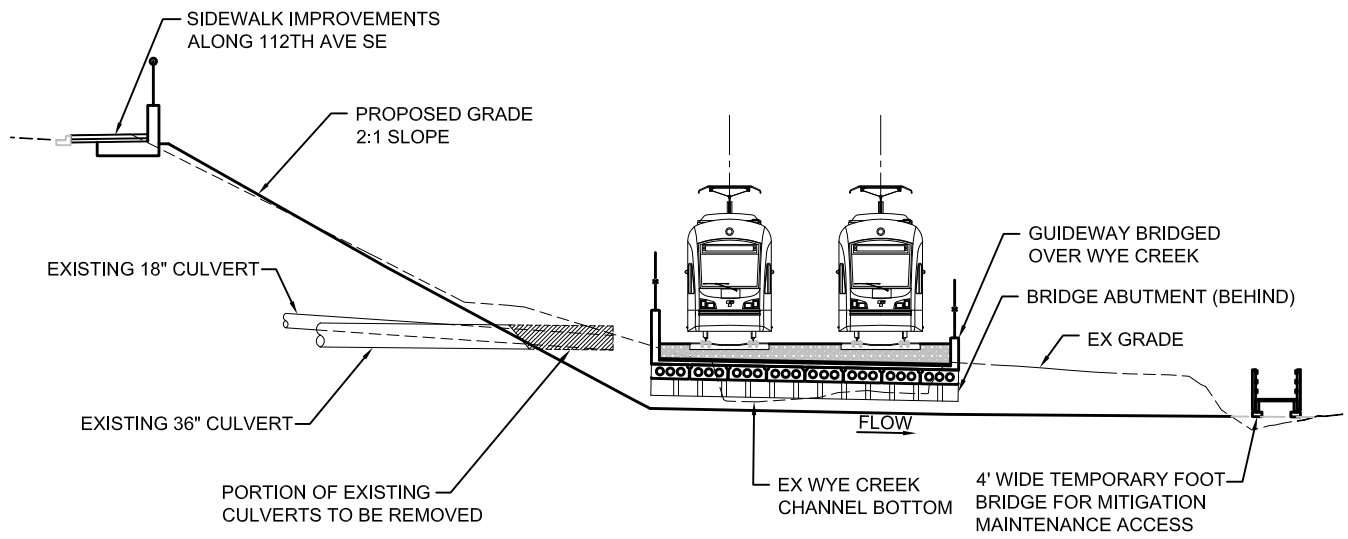

WYE CREEK - SECTION 1
N.T.S.

05/05/15 | 1:17 PM | JLOGAN | J:\55229\CADD\5001\DRAWINGS\ARCH\CRITICAL AREAS REPORT\IMPACTS\IE520-LB5-CARB-9.DWG



FINAL DESIGN PARTNERS.



SOUNDTRANSIT

EAST LINK EXTENSION
SOUTH BELLEVUE TO OVERLAKE TRANSIT CENTER
 APPENDIX B
 FIGURE 9
 WETLAND, STREAM, AND BUFFER IMPACTS

NAME	PERMANENT IMPACTS	TEMPORARY IMPACTS
MERCER SLOUGH WETLAND	0.17 ACRE	0.22 ACRE
MERCER SLOUGH WETLAND BUFFER	4.10 ACRES	4.43 ACRES

NOTES:

- VALUES REPRESENT IMPACTS TO ENTIRE CRITICAL AREA, NOT JUST AREA SHOWN ON THIS SHEET.
- OVERLAPPING WETLAND AND STREAM BUFFER AREAS ARE SHOWN AS WETLAND BUFFERS. STREAM BUFFER IS ONLY SHOWN WHERE THERE IS NO WETLAND BUFFER OVERLAP.
- SHORELINE CRITICAL AREA BUFFERS ARE ENCOMPASSED WITHIN STREAM AND WETLAND BUFFER AREAS.

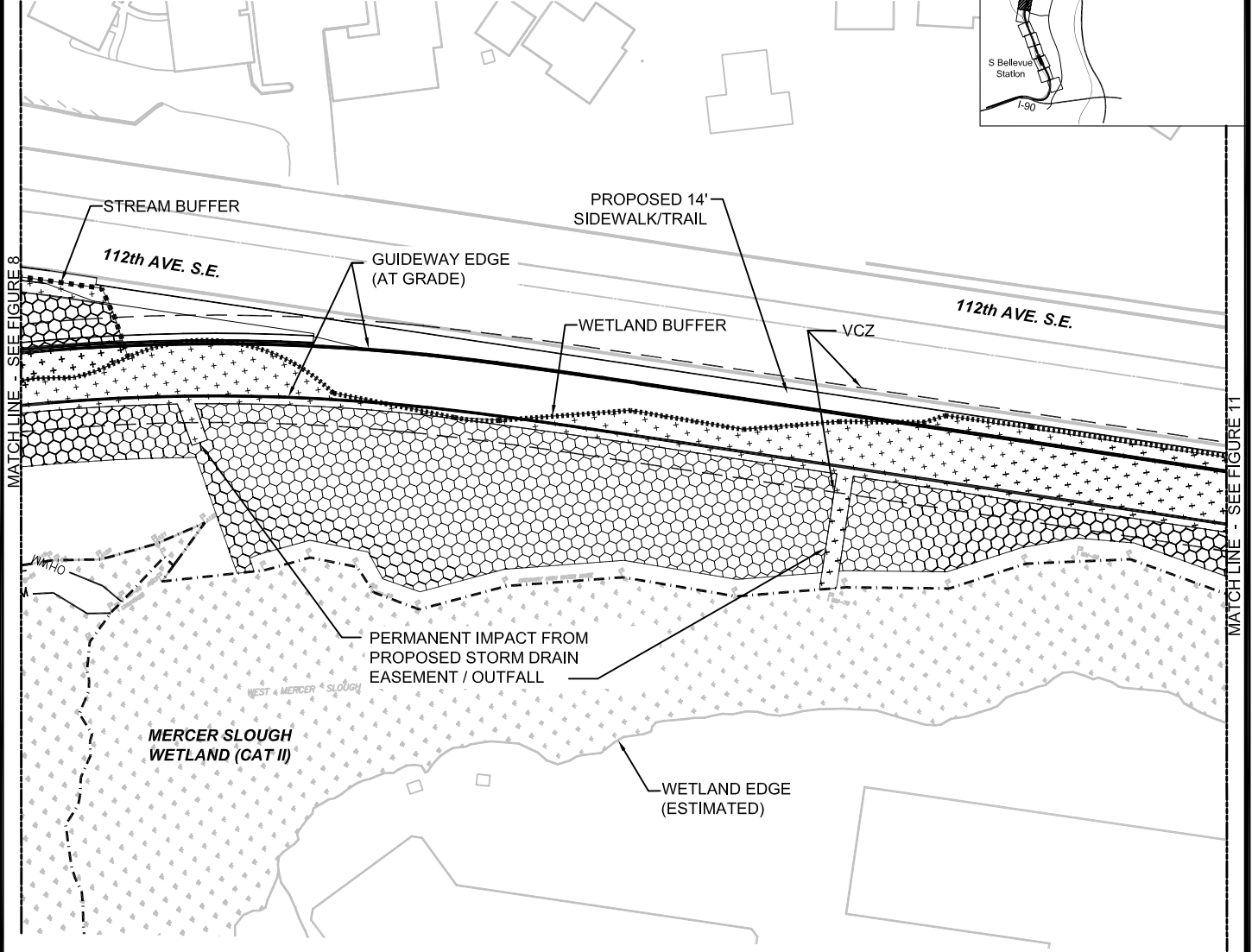
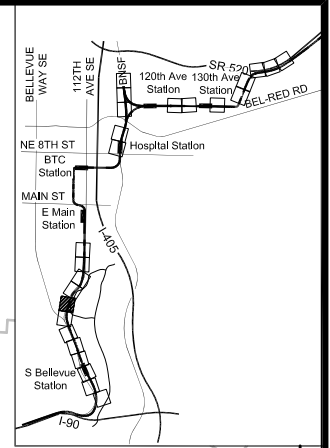

LEGEND

- TEMPORARY BUFFER IMPACT
- PERMANENT BUFFER IMPACT
- EXISTING WETLAND
- EXISTING WETLAND BUFFER
- EXISTING STREAM BUFFER
- OHWM ORDINARY HIGH WATER MARK
- VEGETATION CLEAR ZONE (VCZ)

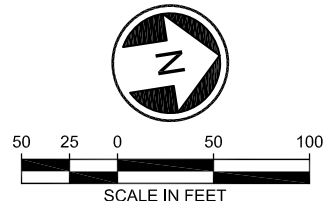

04/29/15 | 2:00 PM | J.LOGAN | J:\65229\CADD\5001\DRAWINGS\ARCH\CRITICAL AREAS REPORT\IMPACTS\IES204-L85-CARB.DWG

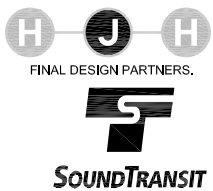

EAST LINK EXTENSION
SOUTH BELLEVUE TO OVERLAKE TRANSIT CENTER
 APPENDIX B
 FIGURE 10
 WETLAND, STREAM, AND BUFFER IMPACTS



NAME	PERMANENT IMPACTS	TEMPORARY IMPACTS
MERCER SLOUGH WETLAND	0.17 ACRE	0.22 ACRE
MERCER SLOUGH WETLAND BUFFER	4.10 ACRES	4.43 ACRES

NOTES:

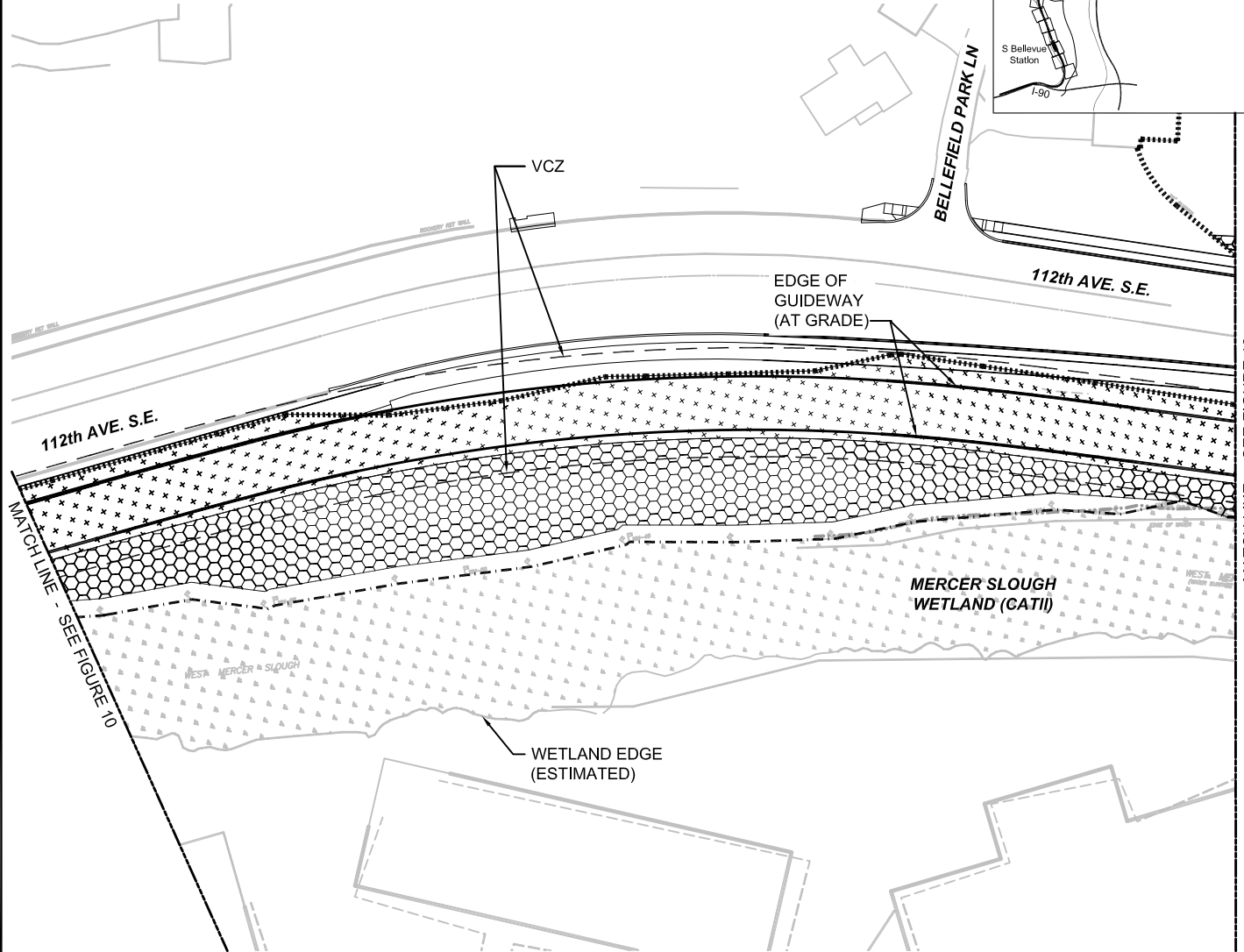
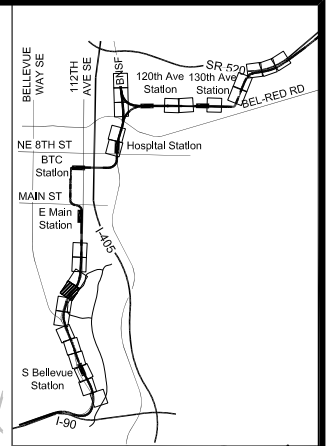
- VALUES REPRESENT IMPACTS TO ENTIRE CRITICAL AREA, NOT JUST AREA SHOWN ON THIS SHEET.
- OVERLAPPING WETLAND AND STREAM BUFFER AREAS ARE SHOWN AS WETLAND BUFFERS. STREAM BUFFER IS ONLY SHOWN WHERE THERE IS NO WETLAND BUFFER OVERLAP.
- SHORELINE CRITICAL AREA BUFFERS ARE ENCOMPASSED WITHIN STREAM AND WETLAND BUFFER AREAS.

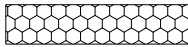
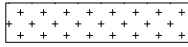

LEGEND

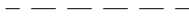
-  TEMPORARY BUFFER IMPACT
-  PERMANENT BUFFER IMPACT
-  EXISTING WETLAND
-  EXISTING WETLAND BUFFER
-  VEGETATION CLEAR ZONE (VCZ)

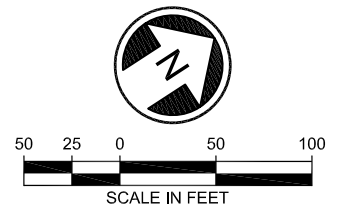

04/29/15 | 2:01 PM | JLOGAN | J:\65229\CADD\5001\DRAWINGS\ARCH\CRITICAL AREAS REPORT\IMPACTS\IE320-L85-CARB.DWG



**EAST LINK EXTENSION
SOUTH BELLEVUE TO OVERLAKE TRANSIT CENTER
APPENDIX B
FIGURE 11
WETLAND, STREAM, AND BUFFER IMPACTS**

NAME	PERMANENT IMPACTS	TEMPORARY IMPACTS
MERCER SLOUGH WETLAND	0.17 ACRE	0.22 ACRE
MERCER SLOUGH WETLAND BUFFER	4.10 ACRES	4.43 ACRES
ALCOVE CREEK	236 SF	33 SF
ALCOVE CREEK WETLAND	NA	0.01 ACRE
ALCOVE CREEK WETLAND BUFFER	0.09 ACRE	0.08 ACRE
BELLEFIELD SOUTH WETLAND	0.05 ACRE	0.04 ACRE
BELLEFIELD SOUTH WETLAND BUFFER	0.20 ACRE	0.01 ACRE
BELLEFIELD NORTH WETLAND	0.01 ACRE	0.02 ACRE
BELLEFIELD NORTH WETLAND BUFFER	0.24 ACRE	0.04 ACRE

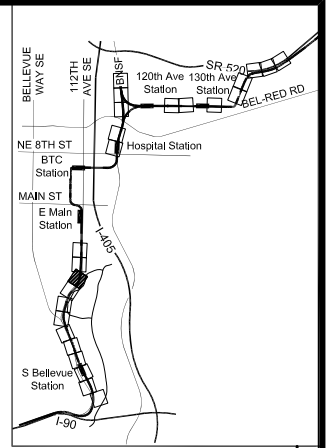

NOTES:

- VALUES REPRESENT IMPACTS TO ENTIRE CRITICAL AREA, NOT JUST AREA SHOWN ON THIS SHEET.
- OVERLAPPING WETLAND AND STREAM BUFFER AREAS ARE SHOWN AS WETLAND BUFFERS. STREAM BUFFER IS ONLY SHOWN WHERE THERE IS NO WETLAND BUFFER OVERLAP.
- SHORELINE CRITICAL AREA BUFFERS ARE ENCOMPASSED WITHIN STREAM AND WETLAND BUFFER AREAS.

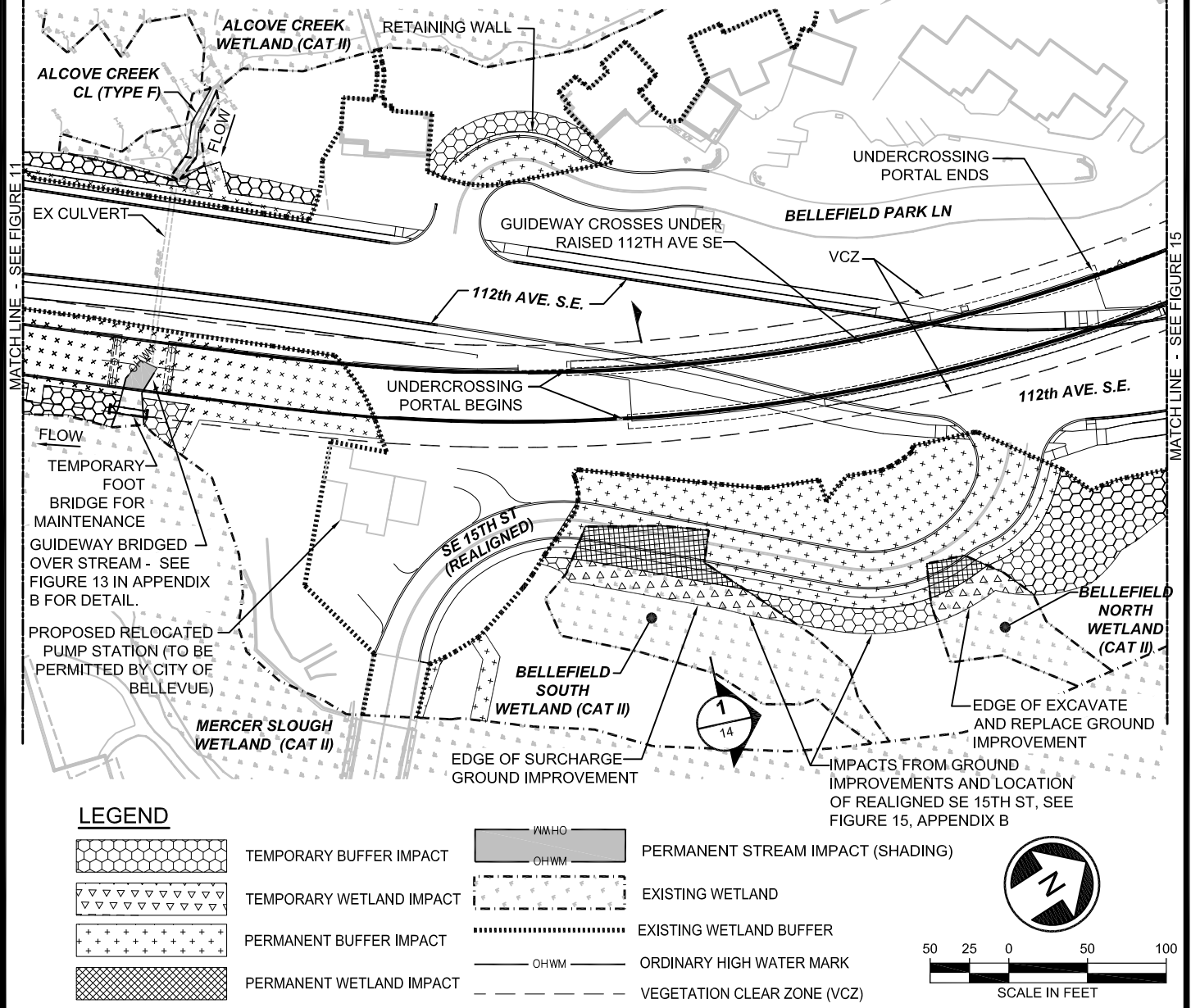

LEGEND

- | | | | | | |
|--|--------------------------|--|------|--|-----------------------------------|
| | TEMPORARY BUFFER IMPACT | | WMHO | | PERMANENT STREAM IMPACT (SHADING) |
| | TEMPORARY WETLAND IMPACT | | OHWM | | EXISTING WETLAND |
| | PERMANENT BUFFER IMPACT | | | | EXISTING WETLAND BUFFER |
| | PERMANENT WETLAND IMPACT | | | | ORDINARY HIGH WATER MARK |
| | | | | | VEGETATION CLEAR ZONE (VCZ) |

04/29/15 | 2:02 PM | J.LOGAN | J:\65229\CADD\5001\DRAWINGS\ARCH\CRITICAL AREAS REPORT\IMPACTS\IE20-L85-CARB.DWG

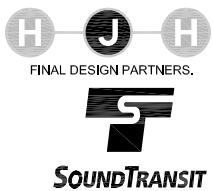

EAST LINK EXTENSION
SOUTH BELLEVUE TO OVERLAKE TRANSIT CENTER
 APPENDIX B
 FIGURE 12
 WETLAND, STREAM, AND BUFFER IMPACTS

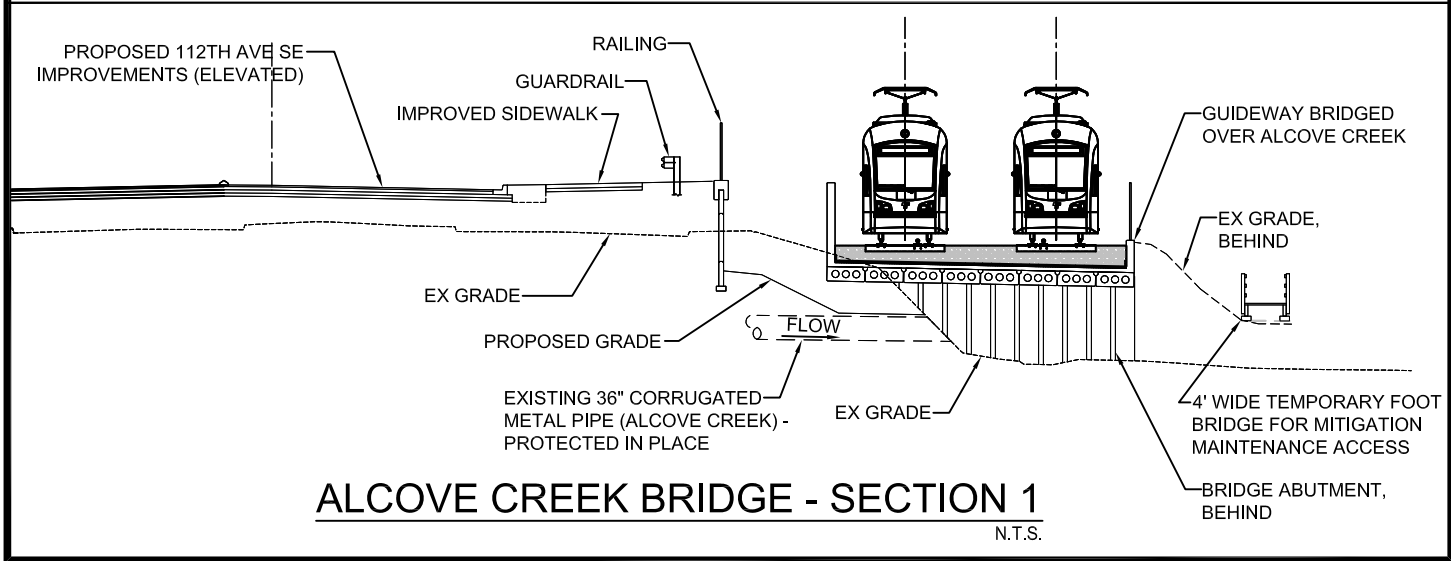
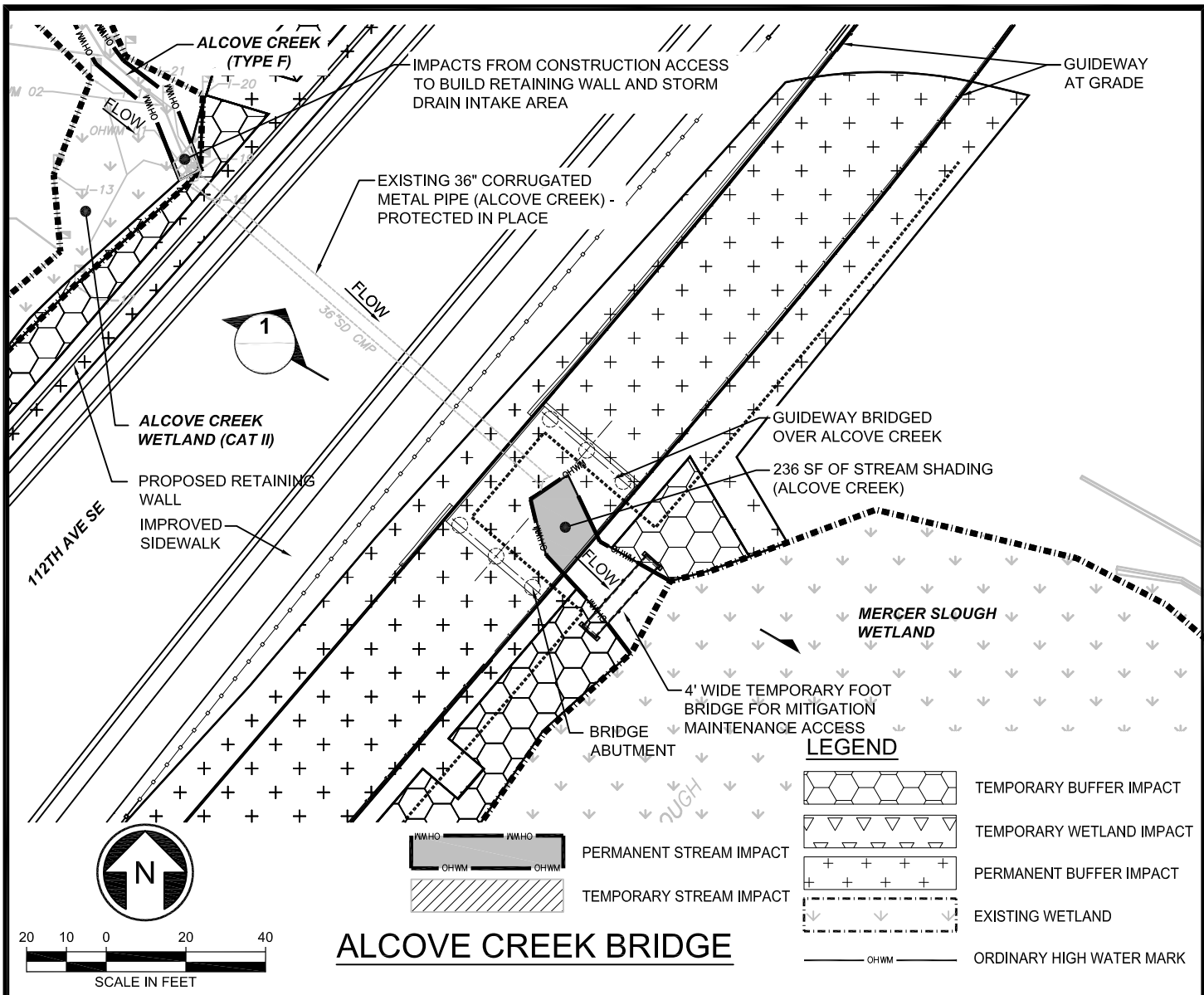

05/05/15 | 1:18 PM | J.LOGAN | J:\55229\CADD\5001\DRAWINGS\ARCH\CRITICAL AREAS REPORT\IMPACTS\IES20-L-85-CARB-13.DWG



EAST LINK EXTENSION
SOUTH BELLEVUE TO OVERLAKE TRANSIT CENTER
 APPENDIX B
 FIGURE 13
 WETLAND, STREAM, AND BUFFER IMPACTS

NOTES:

1. SEE FIGURE 12 FOR PLAN VIEW SHOWING IMPACT AREAS.
2. SURCHARGE MATERIAL ABOVE EXISTING GRADE TO BE REMOVED PRIOR TO VEGETATION INSTALLATION. A MINIMUM OF 3' OF PLANTING TOPSOIL SHALL BE PLACED BELOW EXISTING GRADE.

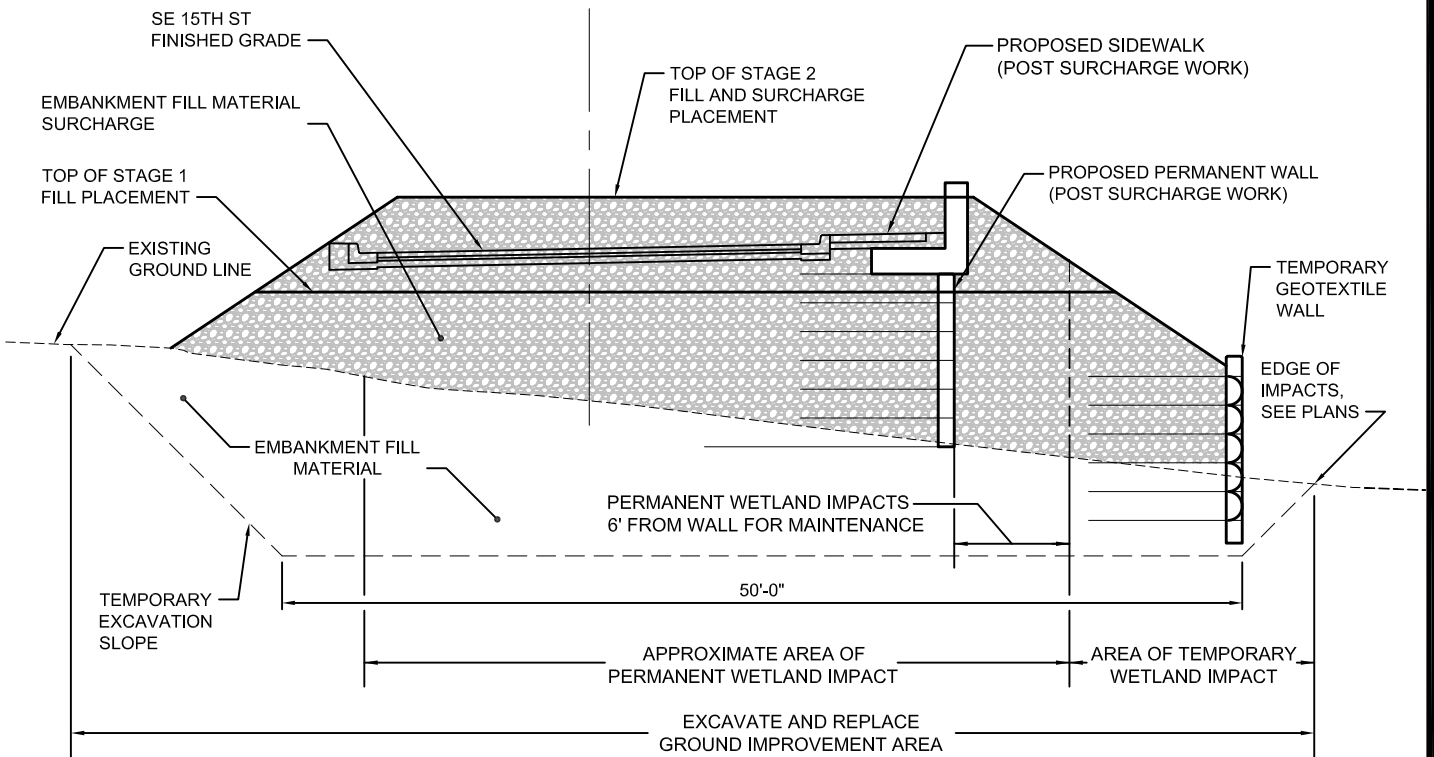

**SE 15TH ST. REALIGNMENT -
SECTION 1**



05/13/15 | 9:15 AM | JLOGAN | J:\55229\CADD\5001\DRAWINGS\ARCH\CRITICAL AREAS REPORT\IMPACTS\IE520-L85-CARB-14.DWG

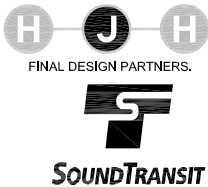

NAME	PERMANENT IMPACTS	TEMPORARY IMPACTS
MERCER SLOUGH WETLAND	0.17 ACRE	0.22 ACRE
MERCER SLOUGH WETLAND BUFFER	4.10 ACRES	4.43 ACRES
8TH STREET WETLAND	0.13 ACRE	NA

NOTES:

- VALUES REPRESENT IMPACTS TO ENTIRE CRITICAL AREA, NOT JUST AREA SHOWN ON THIS SHEET.
- OVERLAPPING WETLAND AND STREAM BUFFER AREAS ARE SHOWN AS WETLAND BUFFERS. STREAM BUFFER IS ONLY SHOWN WHERE THERE IS NO WETLAND BUFFER OVERLAP.
- SHORELINE CRITICAL AREA BUFFERS ARE ENCOMPASSED WITHIN STREAM AND WETLAND BUFFER AREAS.

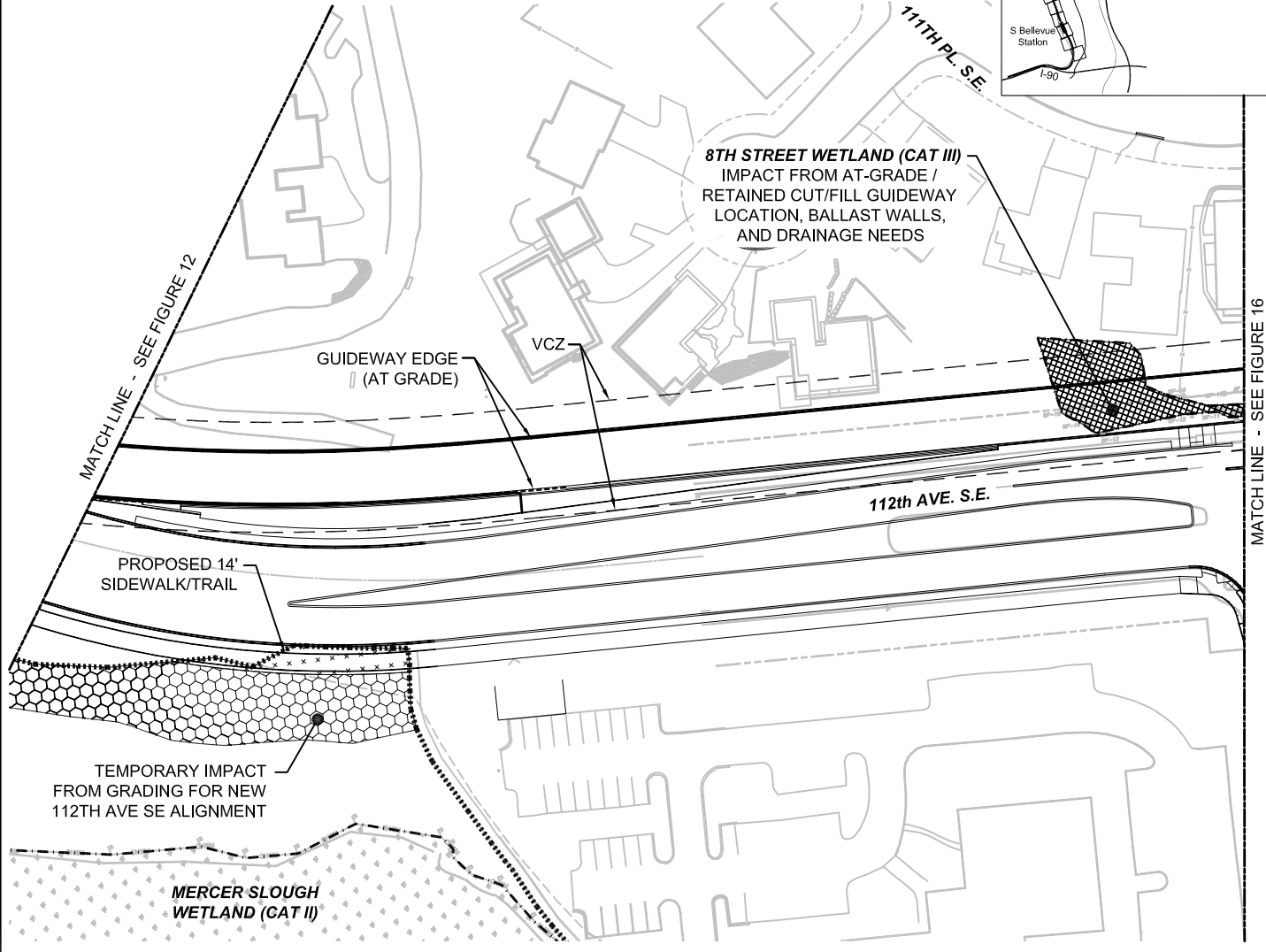
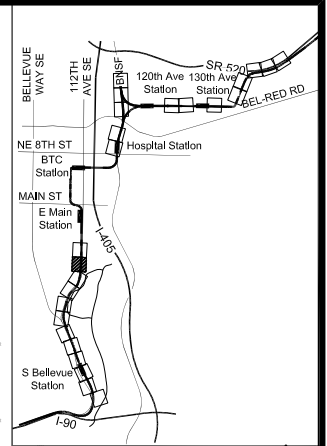

LEGEND

- TEMPORARY BUFFER IMPACT
- PERMANENT WETLAND IMPACT
- EXISTING WETLAND
- EXISTING WETLAND BUFFER
- VEGETATION CLEAR ZONE (VCZ)

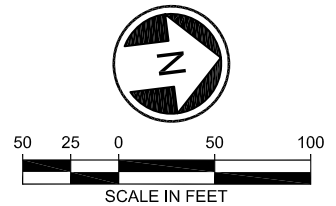

04/29/15 | 2:04 PM | JLOGAN | J:\65229\CADD\5001\DRAWINGS\ARCH\CRITICAL AREAS REPORT\IMPACTS\IE320-L85-CARB.DWG



EAST LINK EXTENSION
SOUTH BELLEVUE TO OVERLAKE TRANSIT CENTER
 APPENDIX B
 FIGURE 15
 WETLAND, STREAM, AND BUFFER IMPACTS

NAME	PERMANENT IMPACTS	TEMPORARY IMPACTS
8TH STREET WETLAND	0.13 ACRE	NA

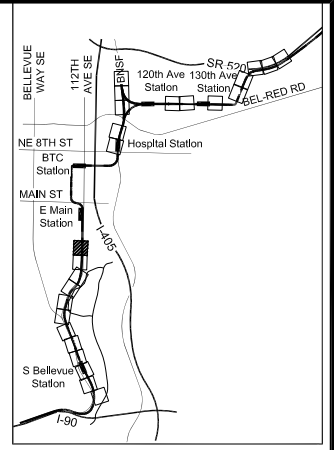

- NOTES:**
- VALUES REPRESENT IMPACTS TO ENTIRE CRITICAL AREA, NOT JUST AREA SHOWN ON THIS SHEET.
 - OVERLAPPING WETLAND AND STREAM BUFFER AREAS ARE SHOWN AS WETLAND BUFFERS. STREAM BUFFER IS ONLY SHOWN WHERE THERE IS NO WETLAND BUFFER OVERLAP.

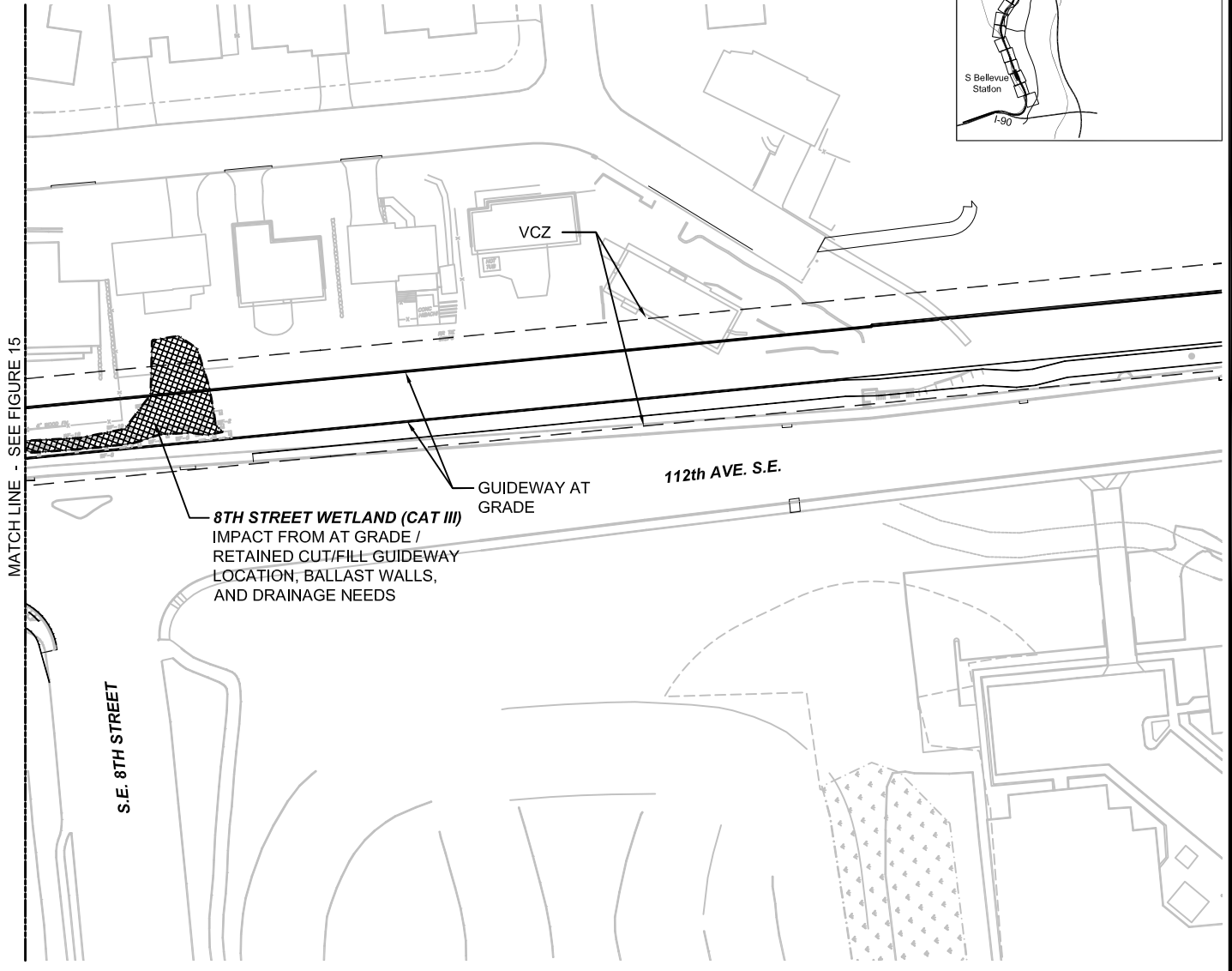

MATCH LINE - SEE FIGURE 15

8TH STREET WETLAND (CAT III)
 IMPACT FROM AT GRADE /
 RETAINED CUT/FILL GUIDEWAY
 LOCATION, BALLAST WALLS,
 AND DRAINAGE NEEDS

GUIDEWAY AT GRADE

112th AVE. S.E.

S.E. 8TH STREET

VCZ

LEGEND

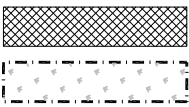

PERMANENT WETLAND IMPACT
 EXISTING WETLAND

..... EXISTING WETLAND BUFFER
 - - - - - VEGETATION CLEAR ZONE (VCZ)

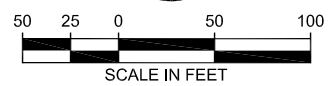

04/29/15 | 2:04 PM | JLOGAN
 J:\65229\CADD\5001\DRAWINGS\ARCH\CRITICAL AREAS REPORT\IMPACTS\IE20-L85-CARB.DWG



EAST LINK EXTENSION
SOUTH BELLEVUE TO OVERLAKE TRANSIT CENTER
 APPENDIX B
 FIGURE 16
 WETLAND, STREAM, AND BUFFER IMPACTS

NAME	PERMANENT IMPACTS	TEMPORARY IMPACTS
STURTEVANT CREEK	3,443 SF	382 SF
STURTEVANT CREEK BUFFER	0.21 ACRE	0.37 ACRE

NOTES:

- VALUES REPRESENT IMPACTS TO ENTIRE CRITICAL AREA, NOT JUST AREA SHOWN ON THIS SHEET.
- OVERLAPPING WETLAND AND STREAM BUFFER AREAS ARE SHOWN AS WETLAND BUFFERS. STREAM BUFFER IS ONLY SHOWN WHERE THERE IS NO WETLAND BUFFER OVERLAP.
- GUIDEWAY CLEARANCE AT COLUMNS NEAR CRITICAL AREAS IS LISTED AS "XX' HT".
- THIS SHEET IS FOR REFERENCE OF ENLARGED FIGURES (SEE FIGURES 18-22; APPENDIX B).

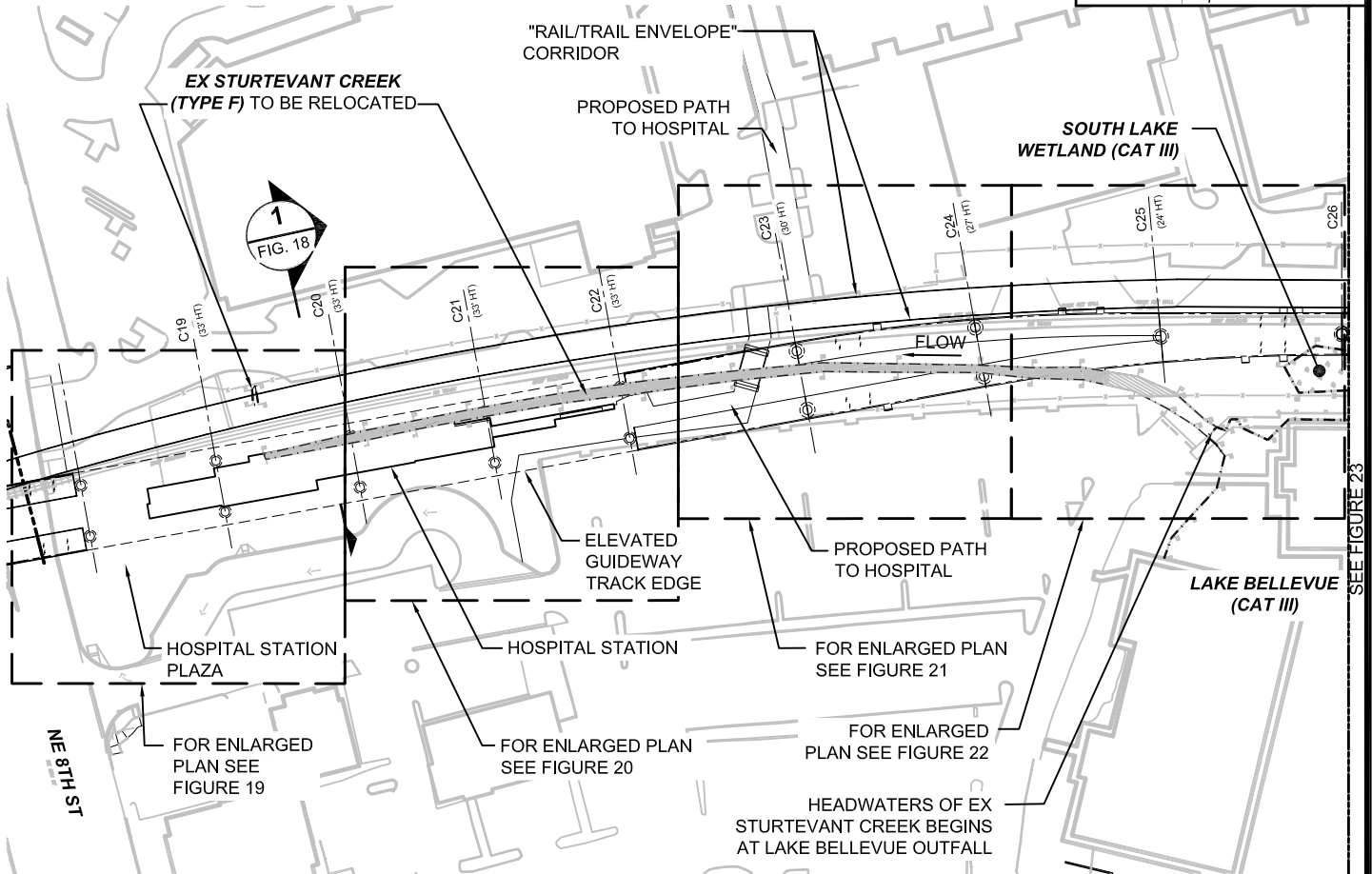
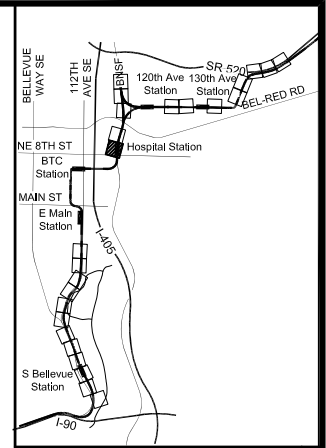

N.T.S.

05/05/15 | 1:22 PM | JLOGAN J:\5229\CADD\DS001\DRAWINGS\LARCH\CRITICAL AREAS REPORT\IMPACTS\E335-L86-CARB.DWG



EAST LINK EXTENSION
SOUTH BELLEVUE TO OVERLAKE TRANSIT CENTER
 APPENDIX B
 FIGURE 17
 WETLAND, STREAM, AND BUFFER IMPACTS

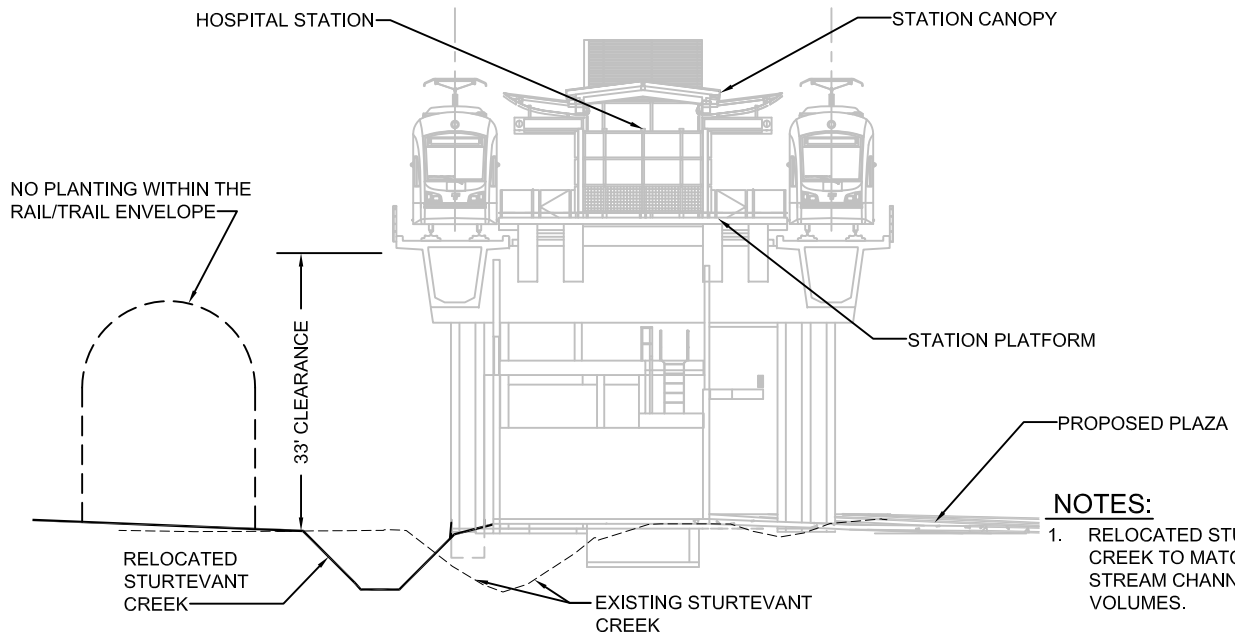

HOSPITAL STATION - SECTION 1



05/05/15 | 1:24 PM | J.LOGAN
J:\55229\CADD\DS001\DRAWINGS\ARCH\CRITICAL AREAS REPORT\IMPACTS\IE35-L86-CARB-18.DWG





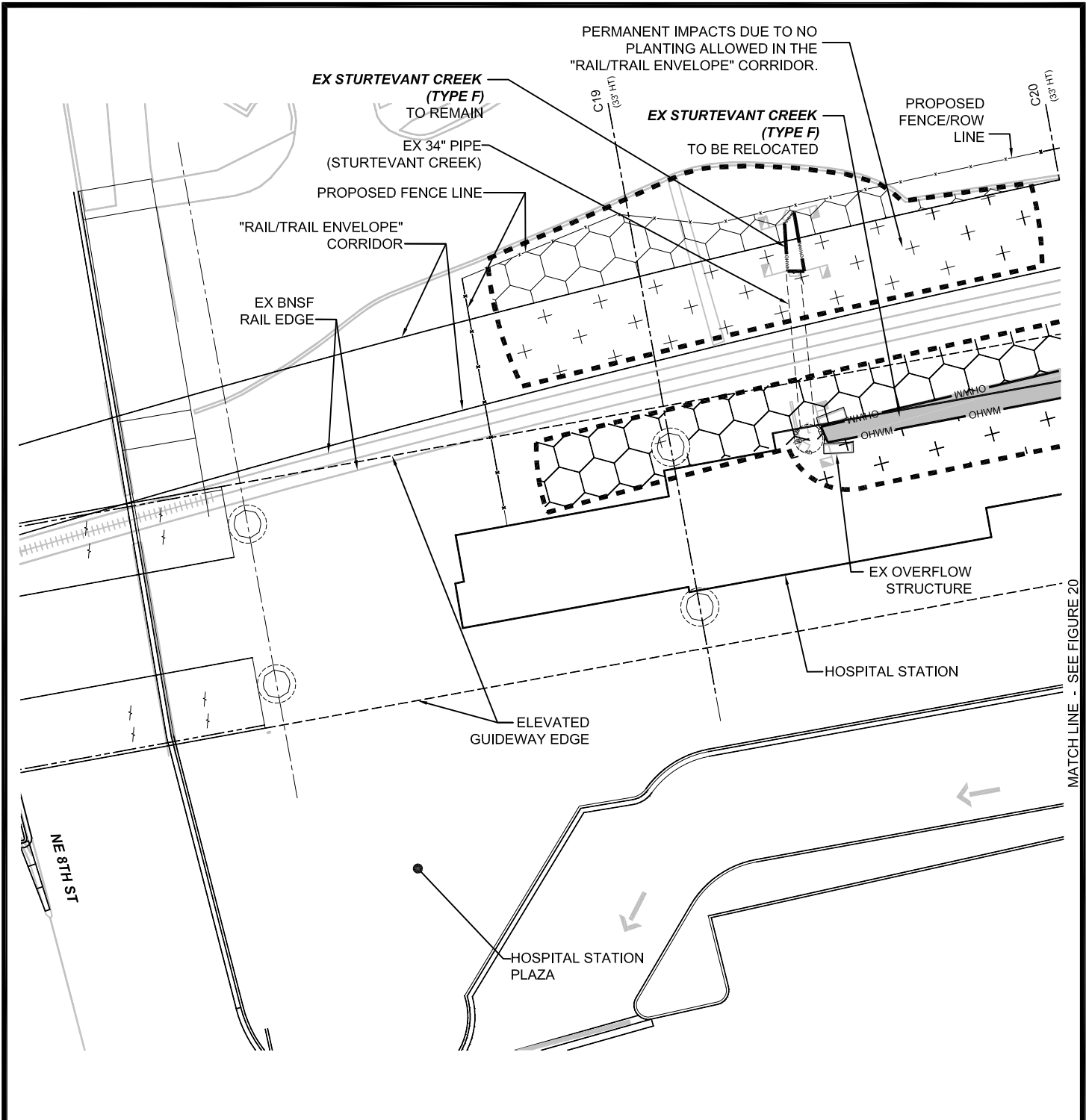

05/05/15 | 2:56 PM | JLOGAN
 J:\5229\CADD\05001\DRAWINGS\LARCH\CRITICAL AREAS REPORT\IMPACTS\ENLARGEMENTS-CARB.DWG

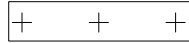

MATCH LINE - SEE FIGURE 20

LEGEND

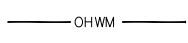
-  TEMPORARY BUFFER IMPACT
-  PERMANENT BUFFER IMPACT
-  PERMANENT STREAM IMPACT
-  EXISTING WETLAND
-  STREAM BUFFER
-  EXISTING ORDINARY HIGH WATER MARK

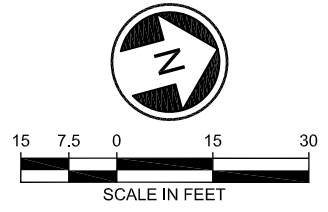

SCALE IN FEET



EAST LINK EXTENSION
SOUTH BELLEVUE TO OVERLAKE TRANSIT CENTER
 APPENDIX B
 FIGURE 19
 WETLAND, STREAM, AND BUFFER IMPACTS

05/05/15 | 2:56 PM | JLOGAN
J:\5229\CADD\05001\DRAWINGS\LARCH\CRITICAL AREAS REPORT\IMPACTS\ENLARGEMENTS-CARB.DWG

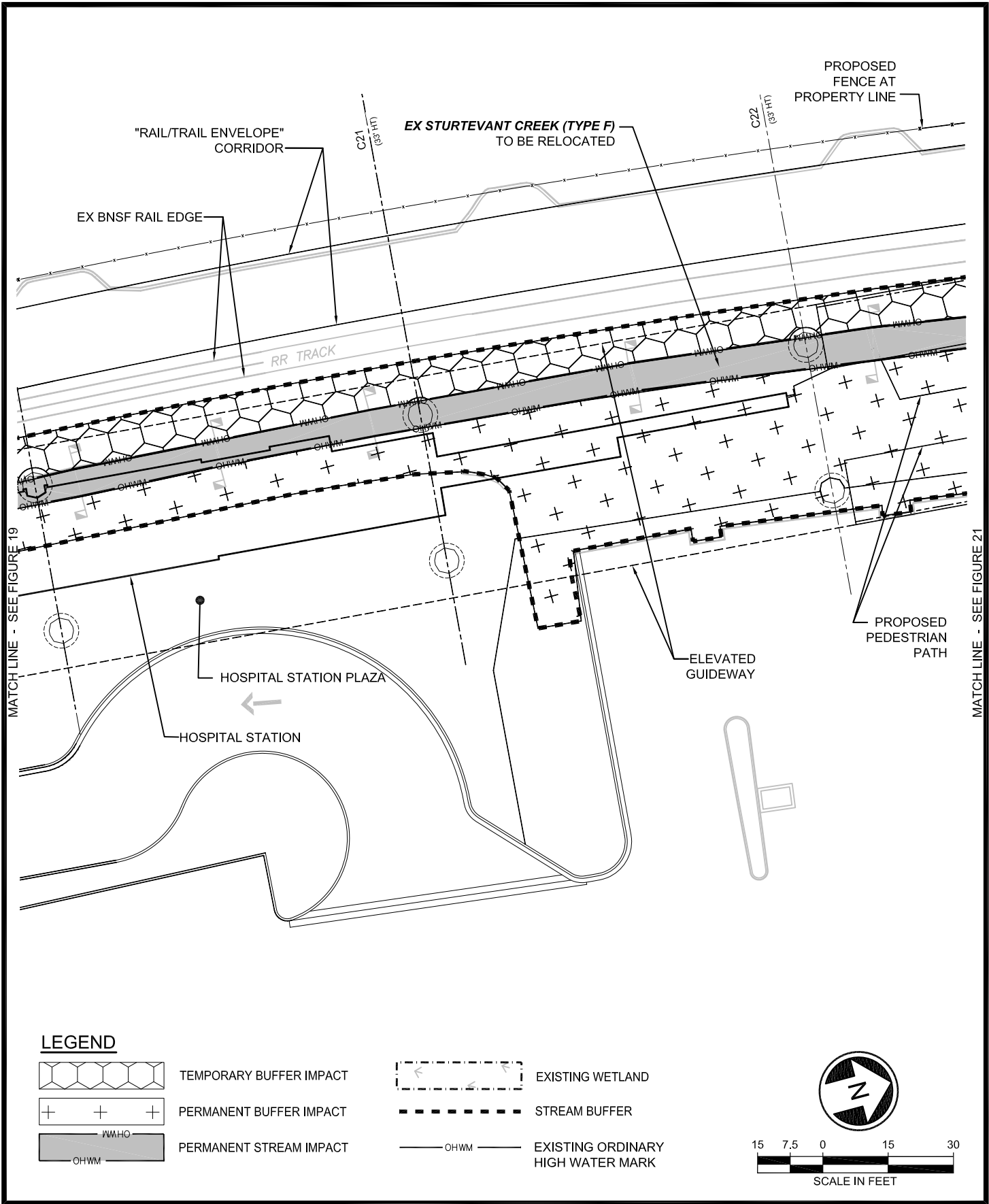

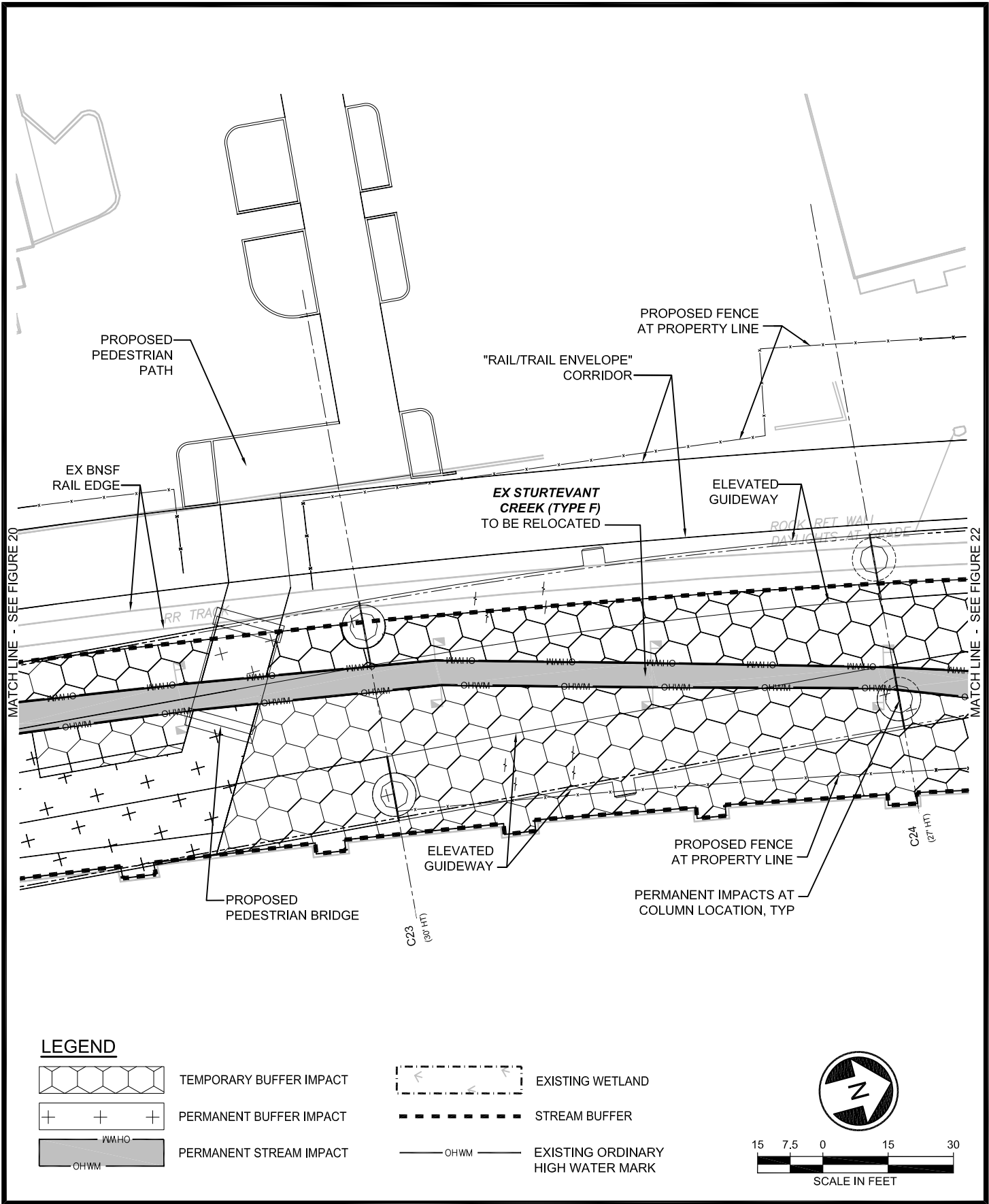

EAST LINK EXTENSION
SOUTH BELLEVUE TO OVERLAKE TRANSIT CENTER
 APPENDIX B
 FIGURE 20
 WETLAND, STREAM, AND BUFFER IMPACTS

05/05/15 | 2:55 PM | JLOGAN
 J:\5229\CADD\0501\DRAWINGS\LARCH\CRITICAL AREAS REPORT\IMPACTS\ENLARGEMENTS-CARB.DWG

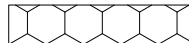
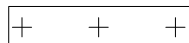
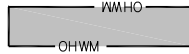

LEGEND

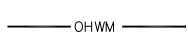
-  TEMPORARY BUFFER IMPACT
-  PERMANENT BUFFER IMPACT
-  PERMANENT STREAM IMPACT
-  EXISTING WETLAND
-  STREAM BUFFER
-  EXISTING ORDINARY HIGH WATER MARK



EAST LINK EXTENSION
SOUTH BELLEVUE TO OVERLAKE TRANSIT CENTER
 APPENDIX B
 FIGURE 21
 WETLAND, STREAM, AND BUFFER IMPACTS

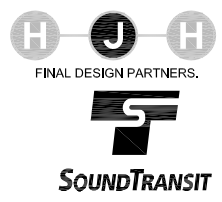

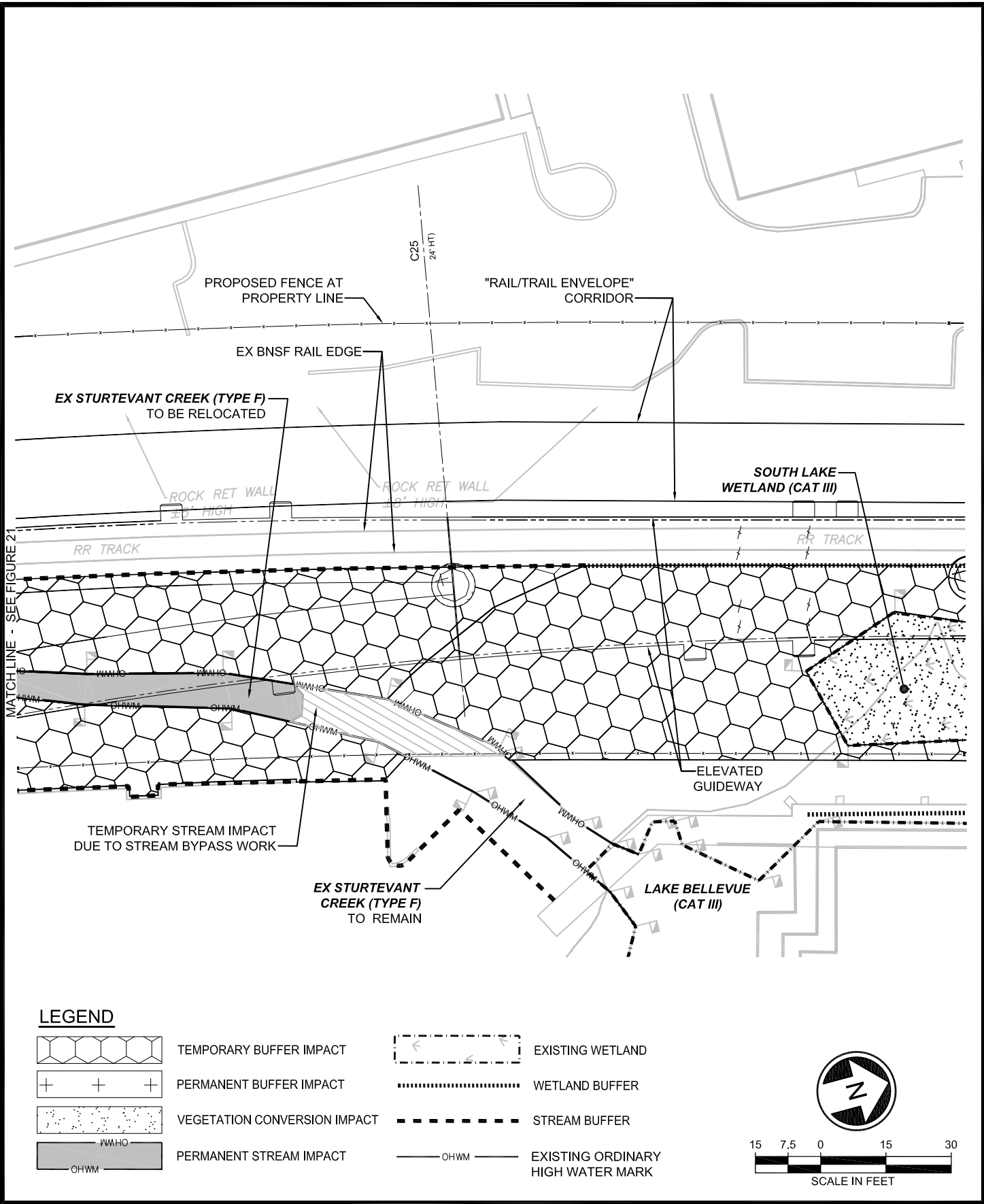

MATCHLINE - SEE FIGURE 21

LEGEND

- | | | | |
|--|------------------------------|--|-----------------------------------|
| | TEMPORARY BUFFER IMPACT | | EXISTING WETLAND |
| | PERMANENT BUFFER IMPACT | | WETLAND BUFFER |
| | VEGETATION CONVERSION IMPACT | | STREAM BUFFER |
| | PERMANENT STREAM IMPACT | | EXISTING ORDINARY HIGH WATER MARK |



EAST LINK EXTENSION
SOUTH BELLEVUE TO OVERLAKE TRANSIT CENTER
 APPENDIX B
 FIGURE 22
 WETLAND, STREAM, AND BUFFER IMPACTS

NAME	PERMANENT IMPACTS	TEMPORARY IMPACTS	VEGETATION CONVERSION IMPACTS
SOUTH LAKE WETLAND	NA	NA	0.09 ACRE
SOUTH LAKE WETLAND BUFFER	0.01 ACRE	0.27 ACRE	NA
CENTRAL LAKE WETLAND	NA	NA	0.03 ACRE
CENTRAL LAKE WETLAND BUFFER	0.05 ACRE	0.09 ACRE	NA
NORTH LAKE WETLAND	NA	0.04 ACRE	NA

NOTES:

1. VALUES REPRESENT IMPACTS TO ENTIRE CRITICAL AREA, NOT JUST AREA SHOWN ON THIS SHEET.
2. OVERLAPPING WETLAND AND STREAM BUFFER AREAS ARE SHOWN AS WETLAND BUFFERS. STREAM BUFFER IS ONLY SHOWN WHERE THERE IS NO WETLAND BUFFER OVERLAP.
3. GUIDEWAY CLEARANCE AT COLUMNS NEAR CRITICAL AREAS IS LISTED AS "XX' HT".

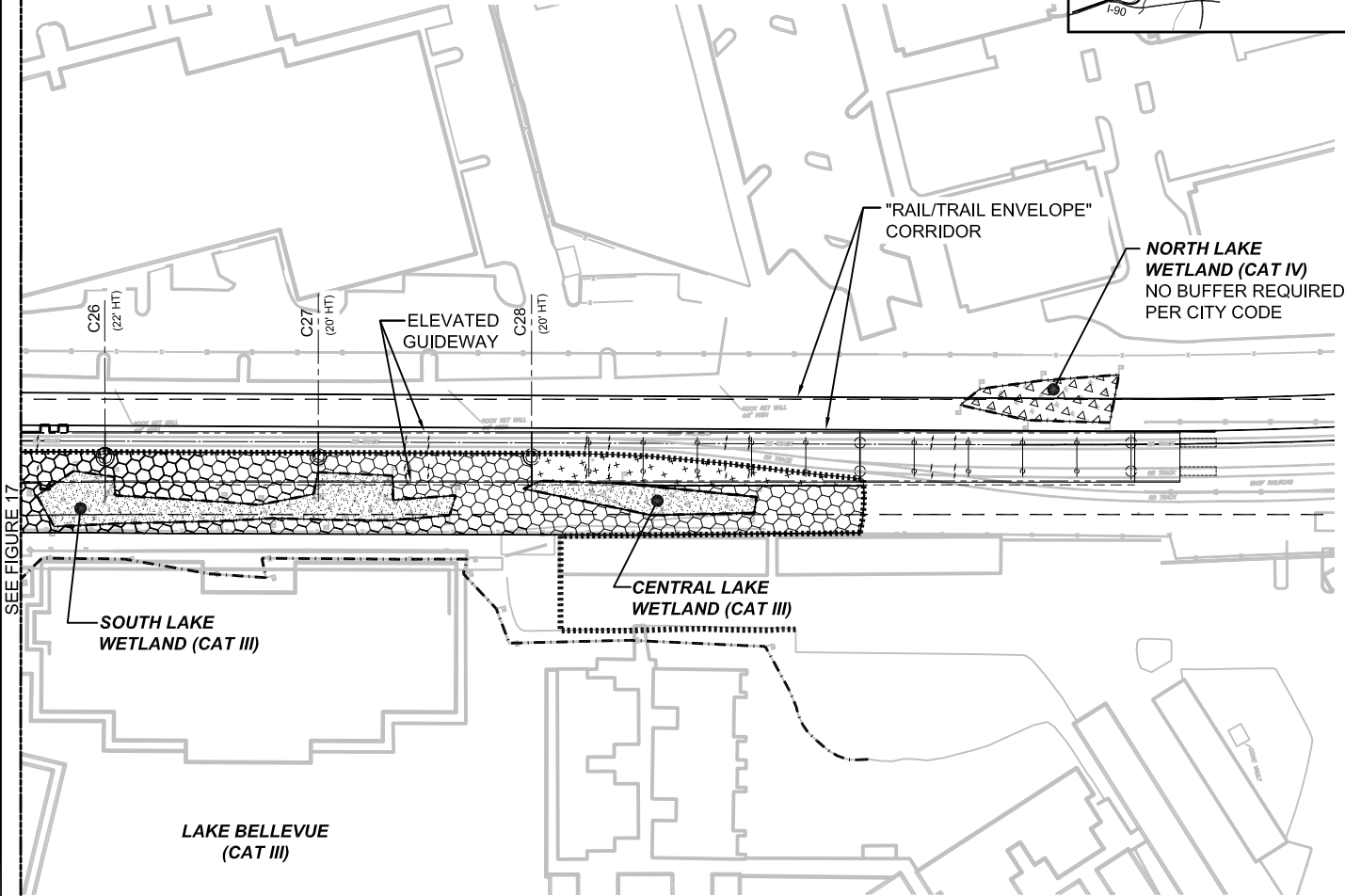
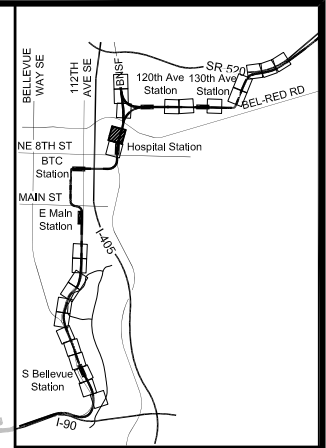

LEGEND

- TEMPORARY BUFFER IMPACT
- TEMPORARY WETLAND IMPACT
- PERMANENT BUFFER IMPACT
- WETLAND VEGETATION CONVERSION IMPACT
- EXISTING WETLAND
- WETLAND BUFFER
- VEGETATION CLEAR ZONE (VCZ)

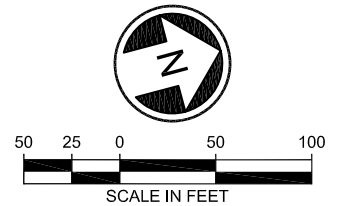

05/26/15 | 10:06 AM | JW.LONG | J:\5229\CADD\DS001\DRAWINGS\ARCH\CRITICAL AREAS REPORT\IMPACTS\E335-L86-CARB.DWG



EAST LINK EXTENSION
SOUTH BELLEVUE TO OVERLAKE TRANSIT CENTER
 APPENDIX B
 FIGURE 23
 WETLAND, STREAM, AND BUFFER IMPACTS

NAME	PERMANENT IMPACTS	TEMPORARY IMPACTS	VEGETATION CONVERSION IMPACTS
BNSF WEST WETLAND BUFFER	0.09 ACRE	NA	NA
BNSF EAST WETLAND	0.05 ACRE	NA	0.08 ACRE
BNSF EAST WETLAND BUFFER	0.14 ACRE	0.01 ACRE	NA

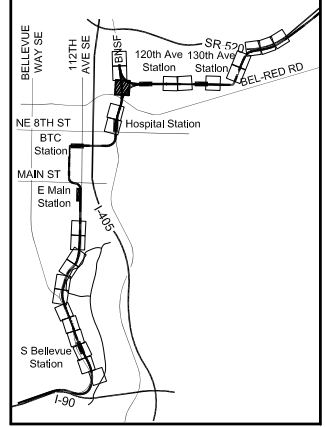

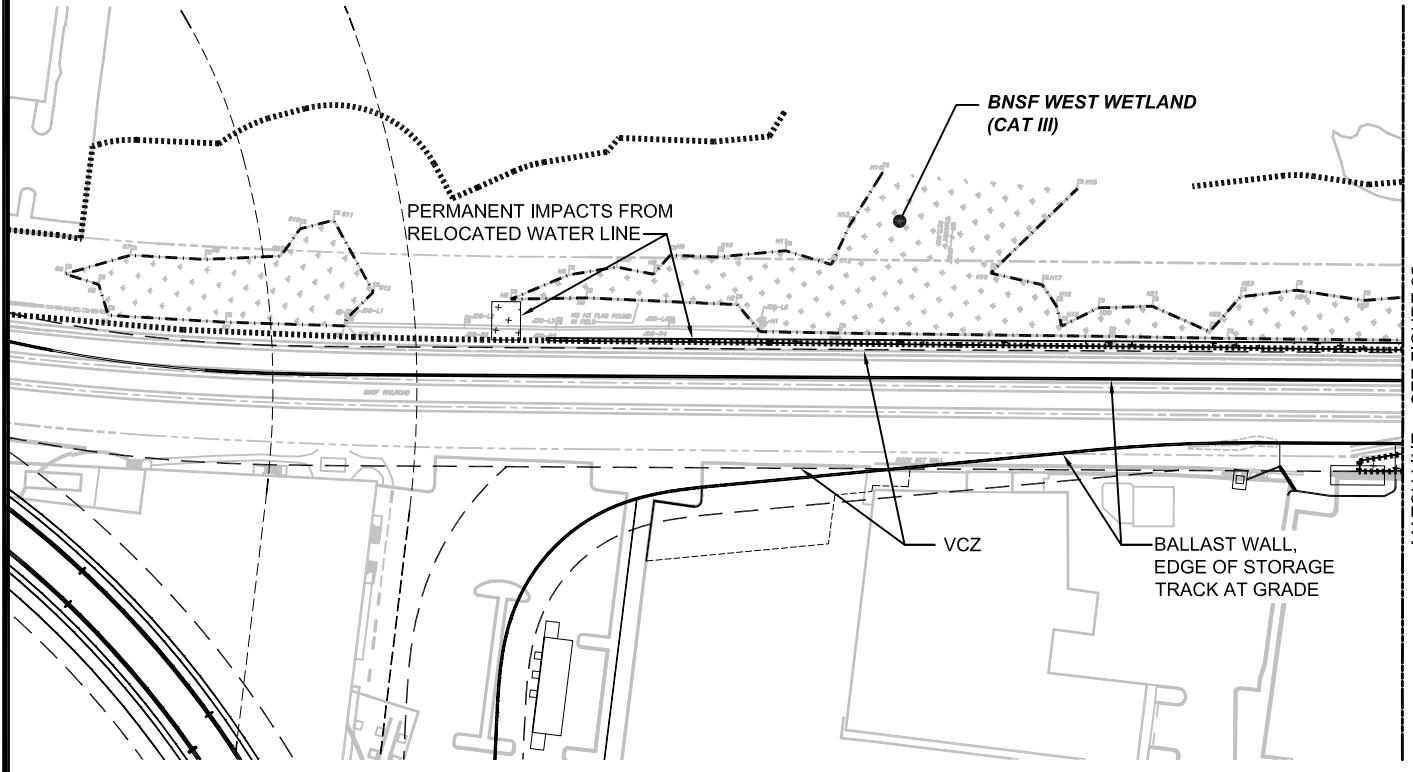

NOTES:

- VALUES REPRESENT IMPACTS TO ENTIRE CRITICAL AREA, NOT JUST AREA SHOWN ON THIS SHEET.

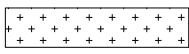

MATCH LINE - SEE FIGURE 25

LEGEND

-  PERMANENT BUFFER IMPACT
-  EXISTING WETLAND
-  WETLAND BUFFER
-  VEGETATION CLEAR ZONE (VCZ)

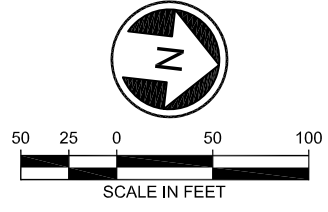

05/05/15 | 1:03 PM | JLOGAN J:\5229\CADD\DS001\DRAWINGS\ARCH\CRITICAL AREAS REPORT\IMPACTS\E340-L87-CARB.DWG

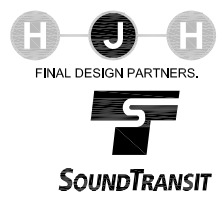

EAST LINK EXTENSION
SOUTH BELLEVUE TO OVERLAKE TRANSIT CENTER
 APPENDIX B
 FIGURE 24
 WETLAND, STREAM, AND BUFFER IMPACTS

NAME	PERMANENT IMPACTS	TEMPORARY IMPACTS	VEGETATION CONVERSION IMPACTS
BNSF WEST WETLAND BUFFER	0.09 ACRE	NA	NA
BNSF EAST WETLAND	0.05 ACRE	NA	0.08 ACRE
BNSF EAST WETLAND BUFFER	0.14 ACRE	0.01 ACRE	NA
BNSF NORTHEAST WETLAND BUFFER	0.04 ACRE	NA	NA

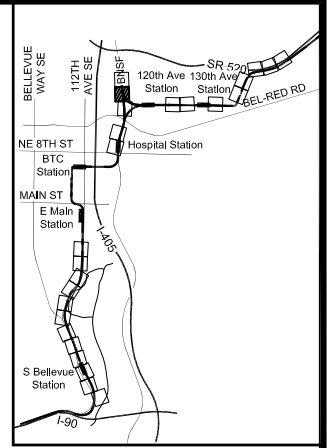

NOTES:

- VALUES REPRESENT IMPACTS TO ENTIRE CRITICAL AREA, NOT JUST AREA SHOWN ON THIS SHEET.

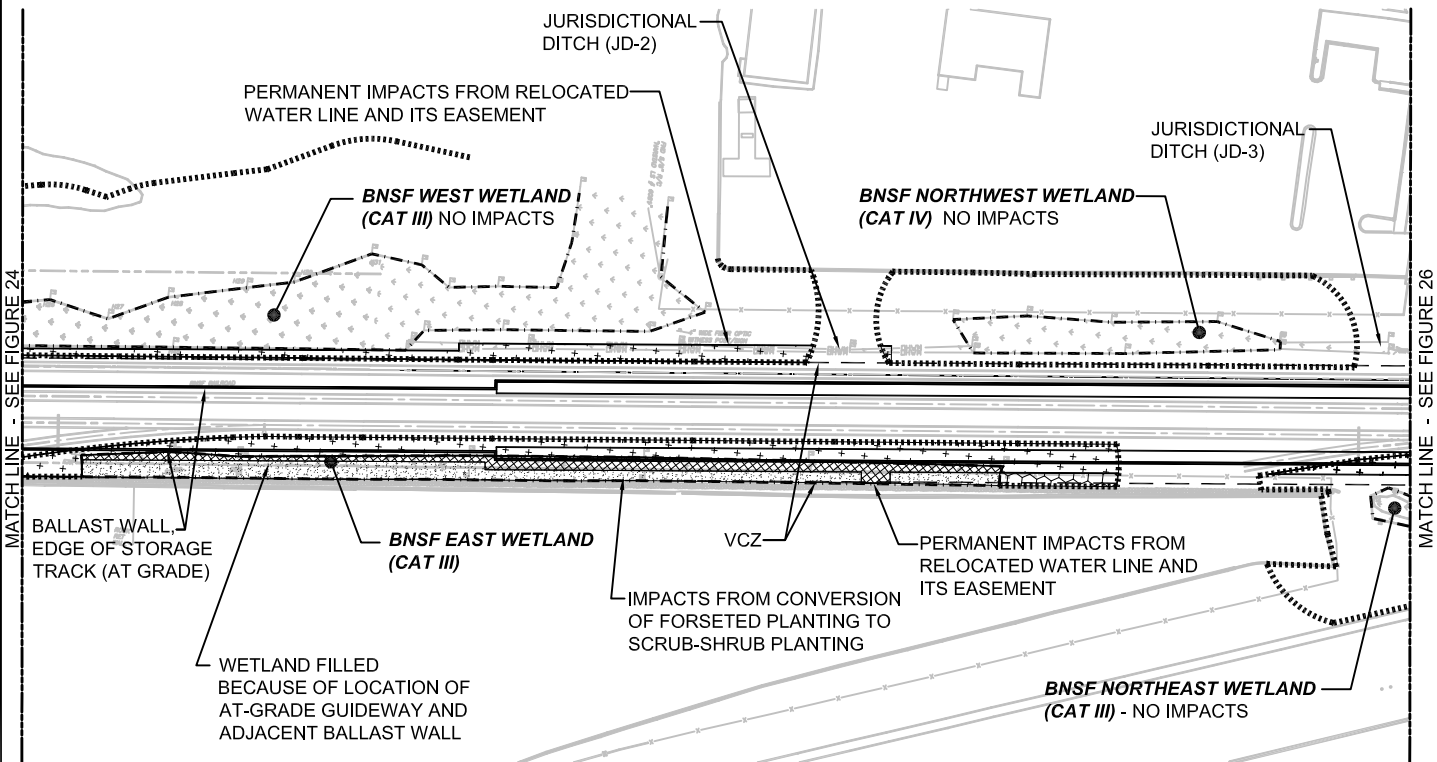

LEGEND

	TEMPORARY BUFFER IMPACT		EXISTING WETLAND
	PERMANENT BUFFER IMPACT		WETLAND BUFFER
	PERMANENT WETLAND IMPACT		VEGETATION CLEAR ZONE (VCZ)
	WETLAND VEGETATION CONVERSION IMPACT		

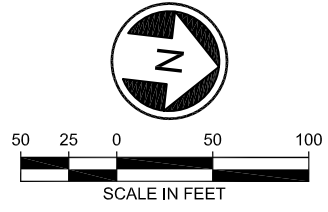

05/13/15 | 9:18 AM | JLOGAN | J:\5229\CADD\001\DRAWINGS\ARCH\CRITICAL AREAS REPORT\IMPACTS\E340-L87-CARB.DWG

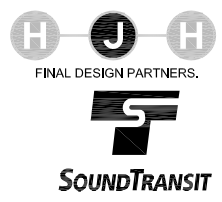

EAST LINK EXTENSION
SOUTH BELLEVUE TO OVERLAKE TRANSIT CENTER
 APPENDIX B
 FIGURE 25
 WETLAND, STREAM, AND BUFFER IMPACTS



NAME	PERMANENT IMPACTS	TEMPORARY IMPACTS
BNSF NORTHEAST WETLAND BUFFER	0.04 ACRE	NA

NOTES:

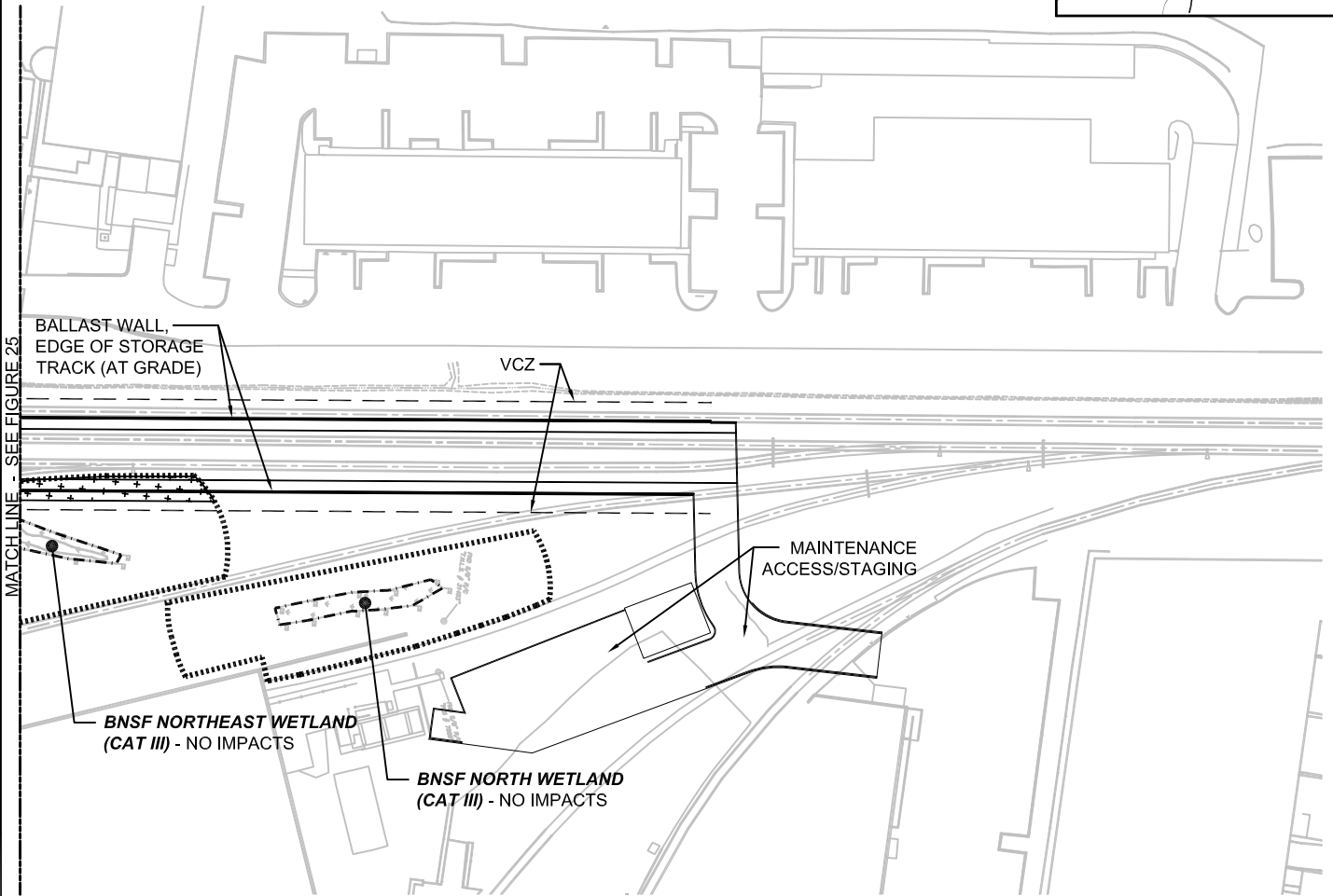
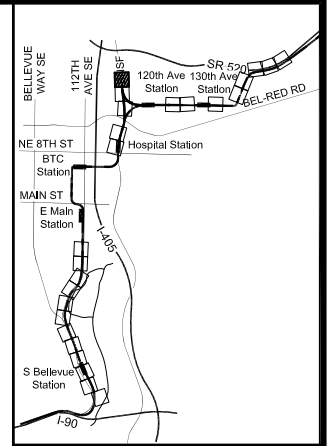
- VALUES REPRESENT IMPACTS TO ENTIRE CRITICAL AREA, NOT JUST AREA SHOWN ON THIS SHEET.

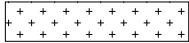

LEGEND

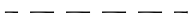
-  PERMANENT BUFFER IMPACT
-  EXISTING WETLAND
-  WETLAND BUFFER
-  VEGETATION CLEAR ZONE (VCZ)

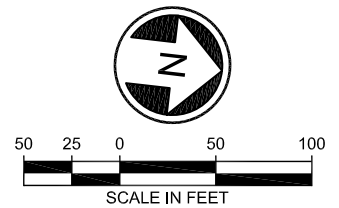

05/05/15 | 1:04 PM | JLOGAN J:\5229\CADD\05001\DRAWINGS\ARCH\CRITICAL AREAS REPORT\IMPACTS\E340-L87-CARB.DWG



EAST LINK EXTENSION
SOUTH BELLEVUE TO OVERLAKE TRANSIT CENTER
 APPENDIX B
 FIGURE 26
 WETLAND, STREAM, AND BUFFER IMPACTS

NAME	PERMANENT IMPACTS	TEMPORARY IMPACTS
KELSEY WEST TRIBUTARY POND WETLAND	0.01 ACRE	0.05 ACRE
KELSEY WEST TRIBUTARY POND WETLAND BUFFER	0.13 ACRE	0.36 ACRE
WEST TRIBUTARY TO KELSEY CREEK	NA	3814 SF
WEST TRIBUTARY TO KELSEY CREEK BUFFER	0.02 ACRE	0.12 ACRE

NOTES:

- VALUES REPRESENT IMPACTS TO ENTIRE CRITICAL AREA, NOT JUST AREA SHOWN ON THIS SHEET.
- OVERLAPPING WETLAND AND STREAM BUFFER AREAS ARE SHOWN AS WETLAND BUFFERS. STREAM BUFFER IS ONLY SHOWN WHERE THERE IS NO WETLAND BUFFER OVERLAP.
- GUIDEWAY CLEARANCE AT COLUMNS NEAR CRITICAL AREAS IS LISTED AS "XX' HT".
- NO SHADING IMPACTS ANTICIPATED FOR KELSEY WEST TRIBUTARY WETLAND POND AND WEST TRIBUTARY TO KELSEY CREEK FOR GUIDEWAY ABOVE 15' HIGH.

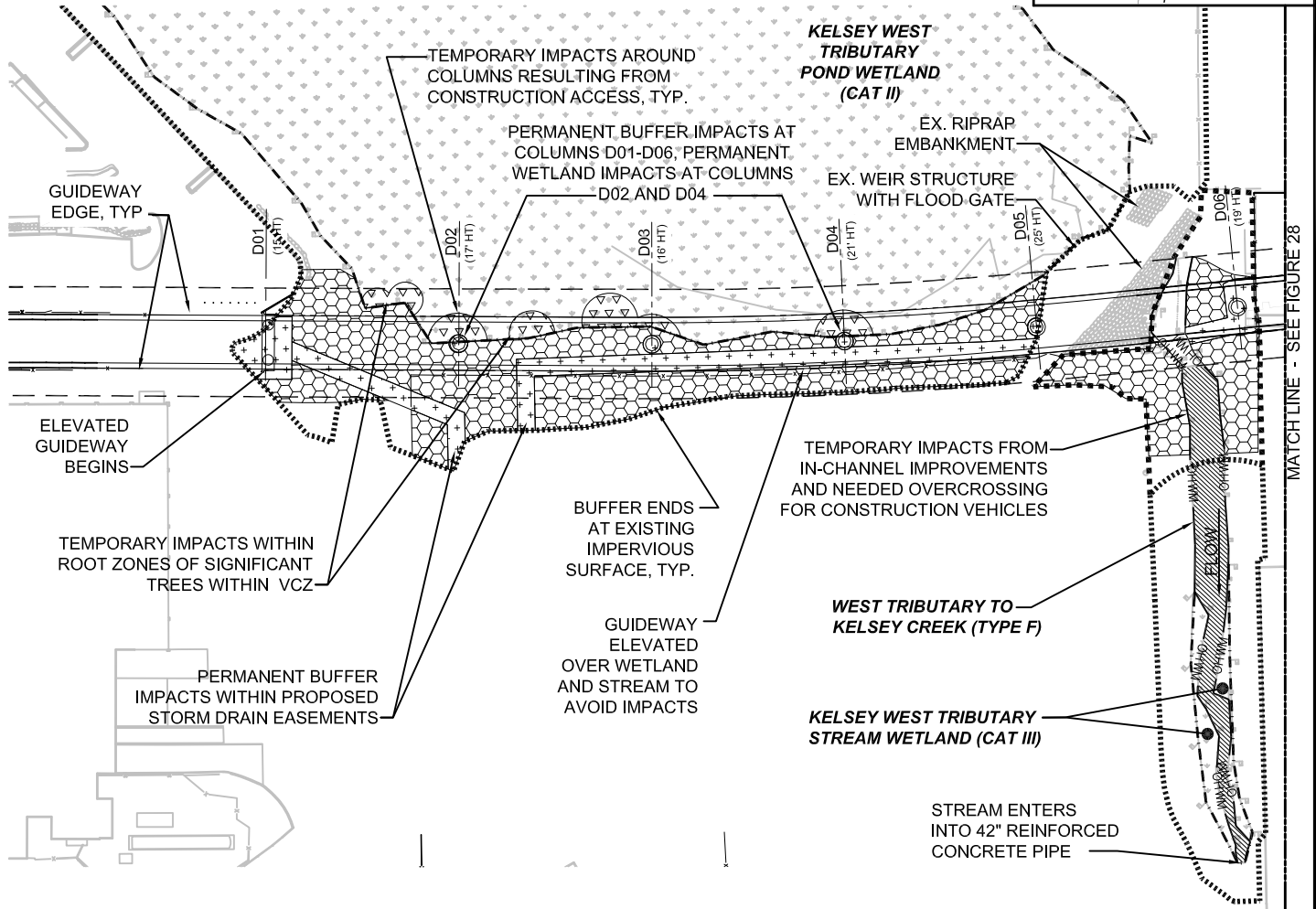
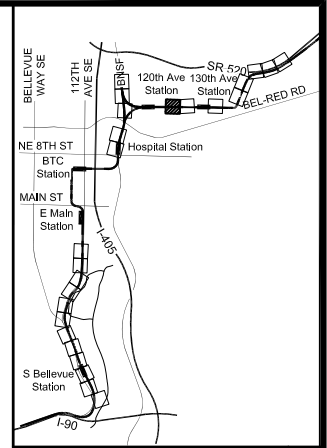

MATCHLINE - SEE FIGURE 28

LEGEND

	TEMPORARY BUFFER IMPACT		EXISTING WETLAND
	TEMPORARY WETLAND IMPACT		WETLAND BUFFER
	PERMANENT BUFFER IMPACT		STREAM BUFFER
	PERMANENT WETLAND IMPACT		ORDINARY HIGH WATER MARK
	TEMPORARY STREAM IMPACT		VEGETATION CLEAR ZONE (VCZ)

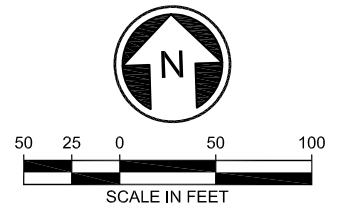

05/05/15 | 1:02 PM | JLOGAN
J:\5229\CADD\05001\DRAWINGS\ARCH\CRITICAL AREAS REPORT\IMPACTS\E340L87-CARB.DWG



EAST LINK EXTENSION
SOUTH BELLEVUE TO OVERLAKE TRANSIT CENTER
 APPENDIX B
 FIGURE 27
 WETLAND, STREAM, AND BUFFER IMPACTS

NAME	PERMANENT IMPACTS	TEMPORARY IMPACTS
STREAM C	NA	1,560 SF
STREAM C BUFFER	0.07 ACRE	0.08 ACRE

NOTES:

- VALUES REPRESENT IMPACTS TO ENTIRE CRITICAL AREA, NOT JUST AREA SHOWN ON THIS SHEET.
- GUIDEWAY CLEARANCE AT COLUMNS NEAR CRITICAL AREAS IS LISTED AS "XX' HT".

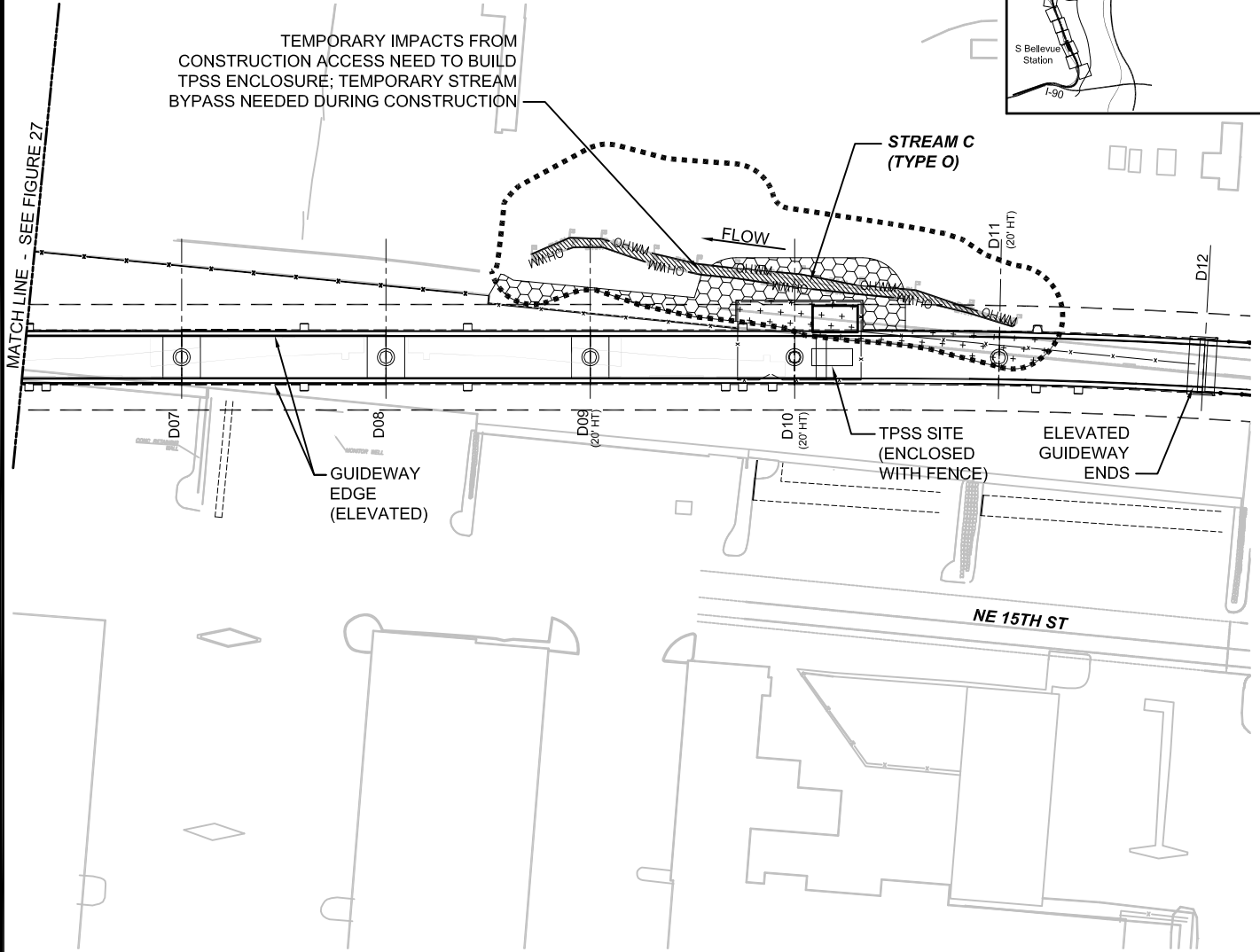
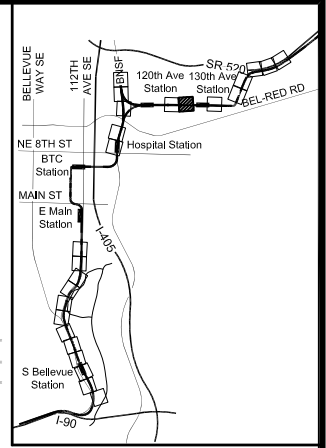

LEGEND

- TEMPORARY BUFFER IMPACT
- PERMANENT BUFFER IMPACT
- TEMPORARY STREAM IMPACT
- STREAM BUFFER
- ORDINARY HIGH WATER MARK
- VEGETATION CLEAR ZONE (VCZ)

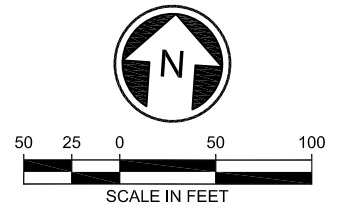

05/05/15 | 1:04 PM | JLOGAN | J:\5229\CADD\05001\DRAWINGS\ARCH\CRITICAL AREAS REPORT\IMPACTS\E340L87-CARB.DWG

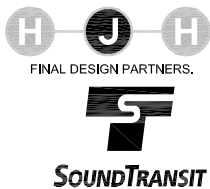

**EAST LINK EXTENSION
SOUTH BELLEVUE TO OVERLAKE TRANSIT CENTER
APPENDIX B
FIGURE 28
WETLAND, STREAM, AND BUFFER IMPACTS**

NAME	PERMANENT IMPACTS	TEMPORARY IMPACTS
GOFF CREEK BUFFER	0.03 ACRE	NA

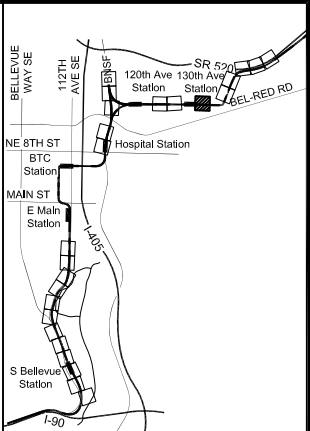

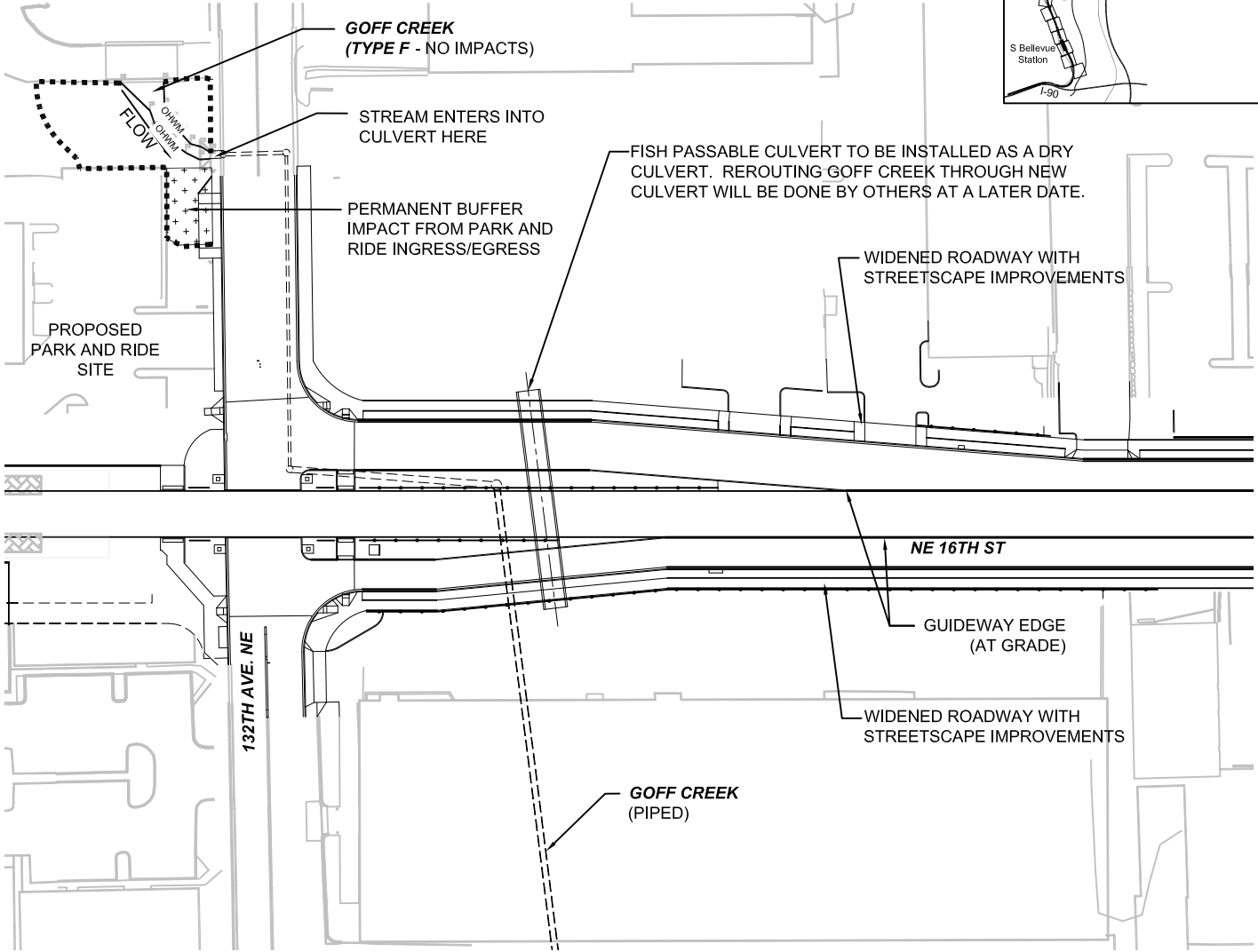

NOTES:

- VALUES REPRESENT IMPACTS TO ENTIRE CRITICAL AREA, NOT JUST AREA SHOWN ON THIS SHEET.

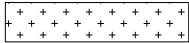

LEGEND

-  PERMANENT BUFFER IMPACT
-  STREAM BUFFER
-  ORDINARY HIGH WATER MARK



05/05/15 | 1:05 PM | JLOGAN J:\55229\CADD\5001\DRAWINGS\ARCH\CRITICAL AREAS REPORT\IMPACTS\E340-L87-CARB.DWG



EAST LINK EXTENSION
SOUTH BELLEVUE TO OVERLAKE TRANSIT CENTER
 APPENDIX B
 FIGURE 29
 WETLAND, STREAM, AND BUFFER IMPACTS

NAME	PERMANENT IMPACTS	TEMPORARY IMPACTS
UNNAMED TRIBUTARY TO KELSEY CREEK	2,887 SF	139 SF
UNNAMED TRIBUTARY TO KELSEY CREEK BUFFER	0.09 ACRE	NA

NOTES:

- VALUES REPRESENT IMPACTS TO ENTIRE CRITICAL AREA, NOT JUST AREA SHOWN ON THIS SHEET.
- ALL OF UNNAMED TRIBUTARY TO KELSEY CREEK ALONG 136TH PLACE NE IS IMPACTED DUE TO ROADWAY AND SIDEWALK IMPROVEMENTS.
- JURISDICTIONAL DITCH IMPACTS ARE DISCUSSED IN THE JARPA APPLICATION FOR THE 404 PERMIT.

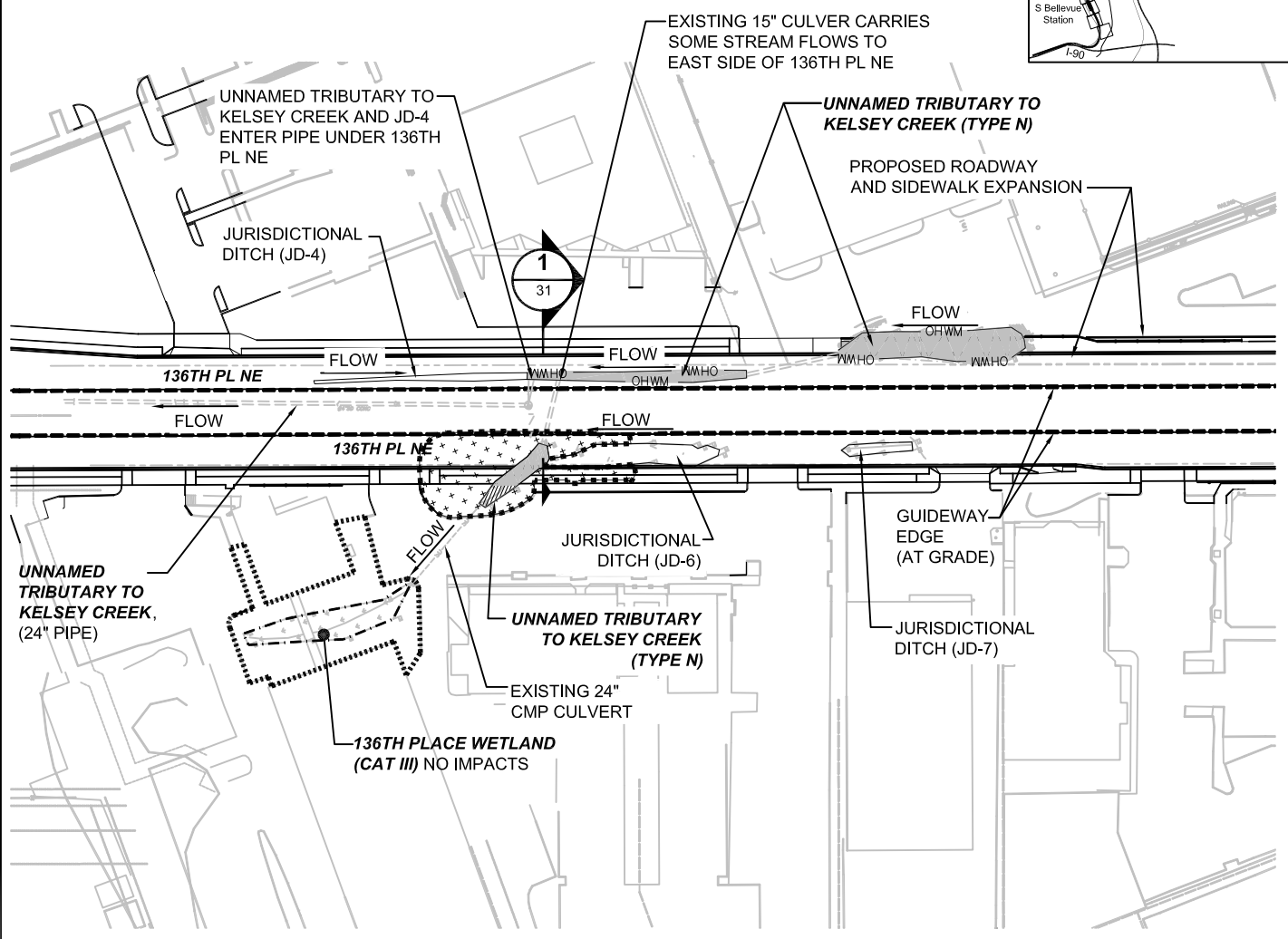
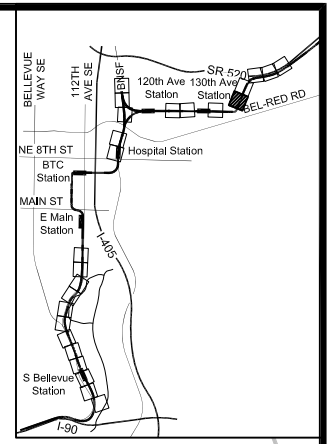

LEGEND

	TEMPORARY BUFFER IMPACT		EXISTING WETLAND
	PERMANENT BUFFER IMPACT		WETLAND BUFFER
	PERMANENT STREAM IMPACT		STREAM BUFFER
	TEMPORARY STREAM IMPACT		ORDINARY HIGH WATER MARK

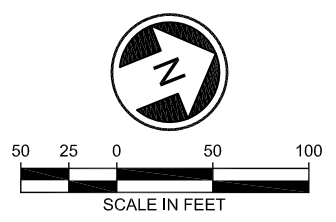

05/05/15 | 1:12 PM | JLOGAN | J:\5229\CADD\DS001\DRAWINGS\ARCH\CRITICAL AREAS REPORT\IMPACTS\E340L87-CARB.DWG

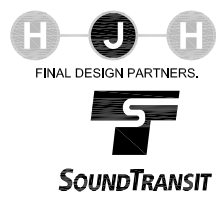

**EAST LINK EXTENSION
SOUTH BELLEVUE TO OVERLAKE TRANSIT CENTER
APPENDIX B
FIGURE 30
WETLAND, STREAM, AND BUFFER IMPACTS**

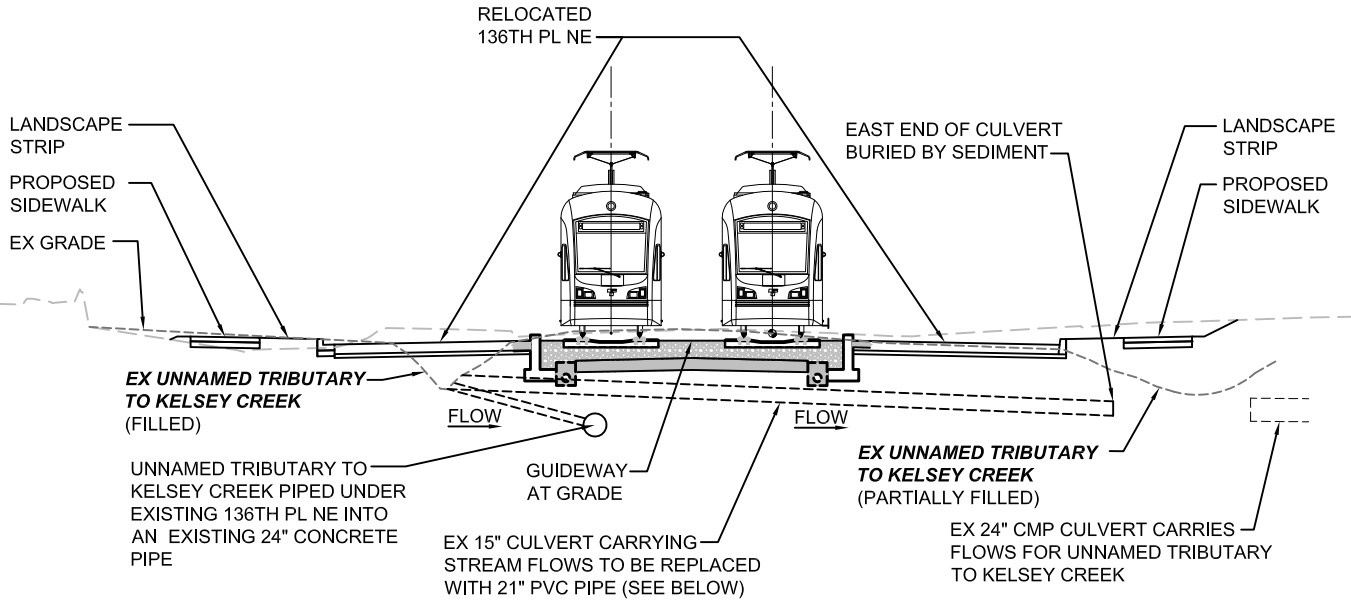

**UNNAMED TRIBUTARY TO KELSEY CREEK -
SECTION 1 (N.T.S.) - IMPACTS**

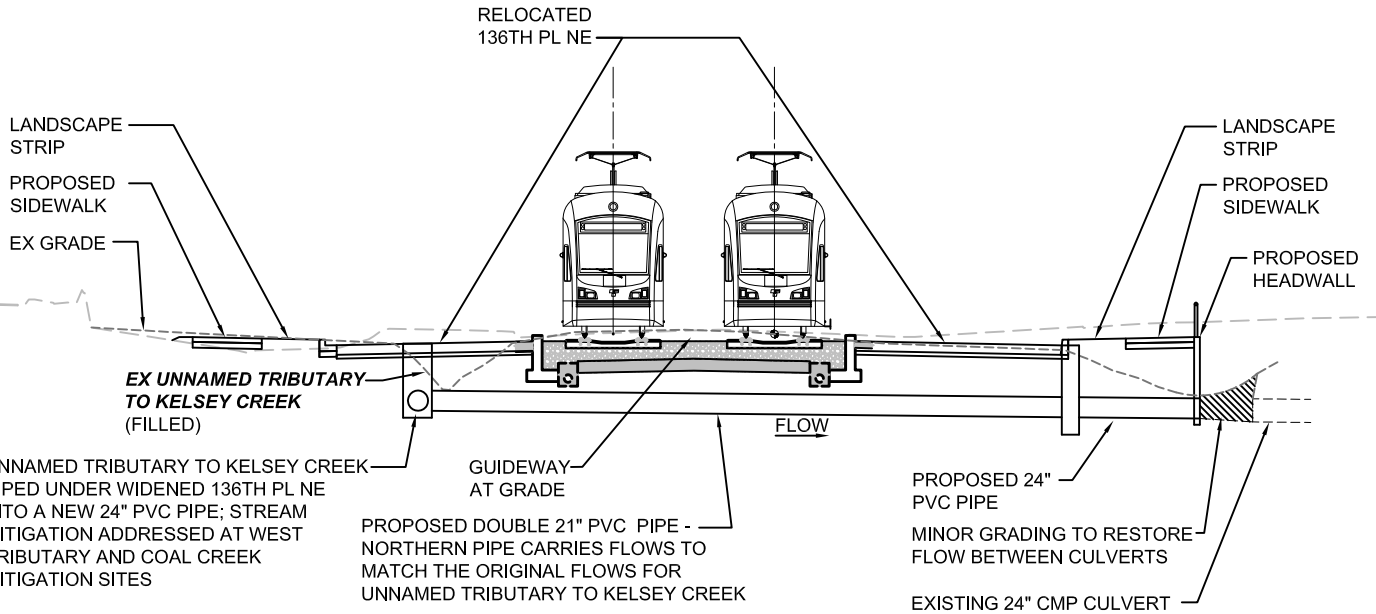

**UNNAMED TRIBUTARY TO KELSEY CREEK -
SECTION 1 (N.T.S.) - MITIGATION**

NOTE: HYDROLOGY WITHIN IMPACTED JURISDICTIONAL DITCHES TO BE ROUTED TO UNNAMED TRIBUTARY TO KELSEY CREEK SO AS TO NOT IMPACT THE 136TH PLACE WETLAND.

05/05/15 | 2:57 PM | JLOGAN | J:\55229\CADD\5001\DRAWINGS\ARCH\CRITICAL AREAS REPORT\IMPACTS\IES340-L87-CARB-31.DWG



NAME	PERMANENT IMPACTS	TEMPORARY IMPACTS	VEGETATION CONVERSION IMPACTS
SR520 WEST WETLAND	0.01 ACRE	NA	0.23 ACRE
SR520 WEST WETLAND BUFFER	0.01 ACRE	0.55 ACRE	NA
VALLEY CREEK WETLAND	NA	NA	0.01 ACRE
VALLEY CREEK WETLAND BUFFER	0.01 ACRE	0.27 ACRE	NA

NOTES:

- VALUES REPRESENT IMPACTS TO ENTIRE CRITICAL AREA, NOT JUST AREA SHOWN ON THIS SHEET.
- GUIDEWAY CLEARANCE AT COLUMNS NEAR CRITICAL AREAS IS LISTED AS "XX' HT".

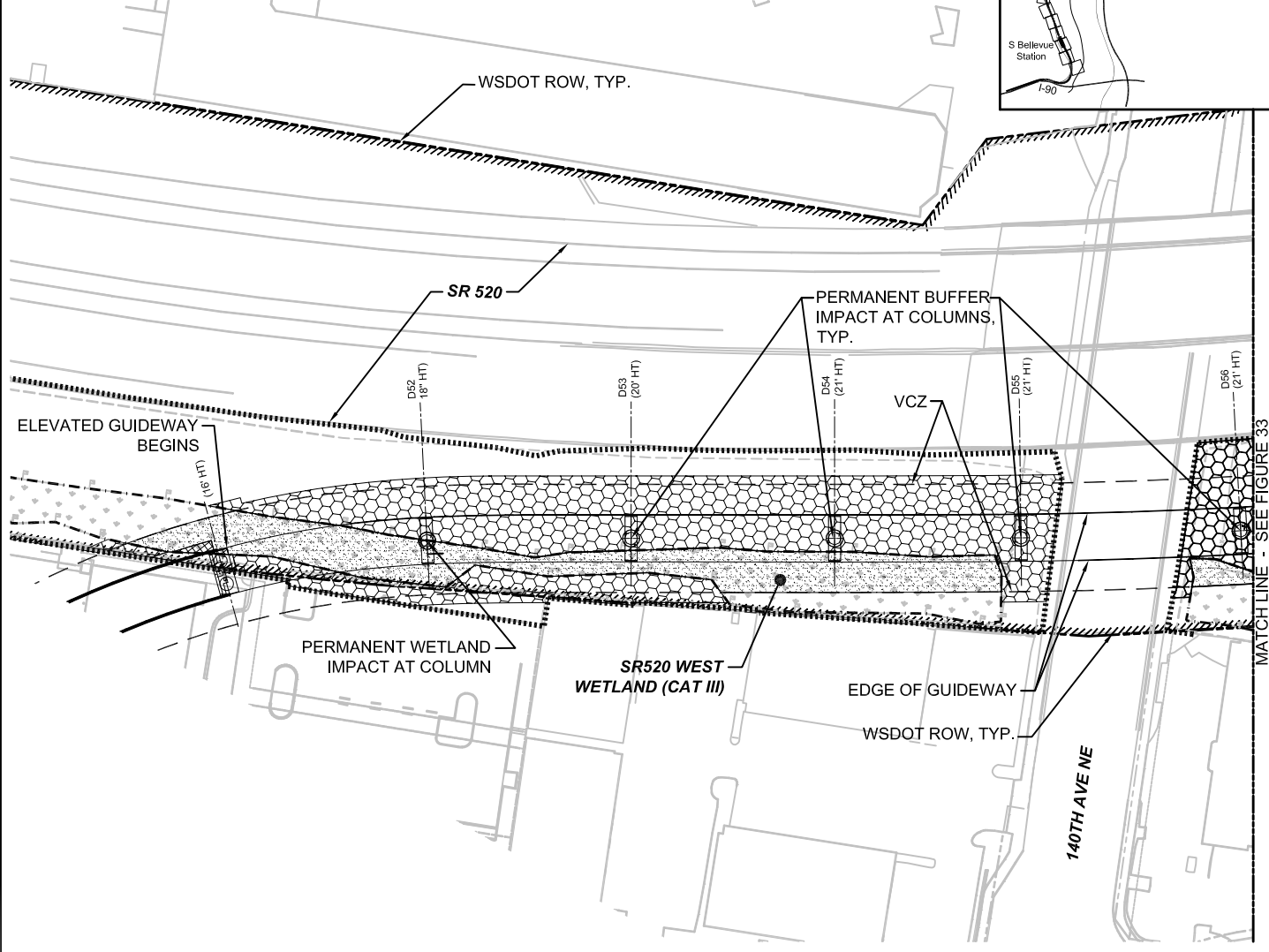
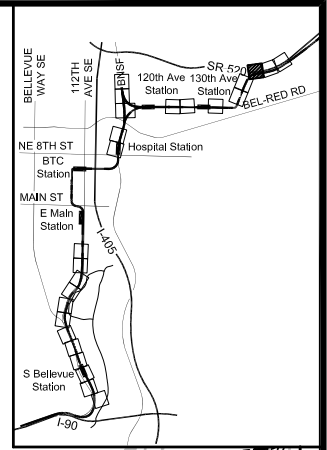

LEGEND

- TEMPORARY BUFFER IMPACT
- PERMANENT BUFFER IMPACT
- PERMANENT WETLAND IMPACT
- WETLAND VEGETATION CONVERSION IMPACT
- EXISTING WETLAND
- EXISTING WETLAND BUFFER
- VEGETATION CLEAR ZONE (VCZ)

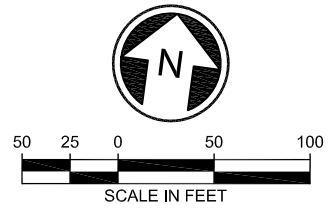

MATCHLINE - SEE FIGURE 33

05/05/15 | 2:59 PM | JLOGAN | J:\5229\CADD\DS001\DRAWINGS\ARCH\CRITICAL AREAS REPORT\IMPACTS\E360L88-CARB.DWG



EAST LINK EXTENSION
SOUTH BELLEVUE TO OVERLAKE TRANSIT CENTER
 APPENDIX B
 FIGURE 32
 WETLAND, STREAM, AND BUFFER IMPACTS

NAME	PERMANENT IMPACTS	TEMPORARY IMPACTS	VEGETATION CONVERSION IMPACTS
VALLEY CREEK WETLAND	NA	NA	0.01 ACRE
VALLEY CREEK WETLAND BUFFER	0.01 ACRE	0.27 ACRE	NA

NOTES:

1. VALUES REPRESENT IMPACTS TO ENTIRE CRITICAL AREA, NOT JUST AREA SHOWN ON THIS SHEET.
2. GUIDEWAY CLEARANCE AT COLUMNS NEAR CRITICAL AREAS IS LISTED AS "XX' HT".
3. OVERLAPPING WETLAND AND STREAM BUFFER AREAS ARE SHOWN AS WETLAND BUFFERS. STREAM BUFFER IS ONLY SHOWN WHERE THERE IS NO WETLAND BUFFER OVERLAP.

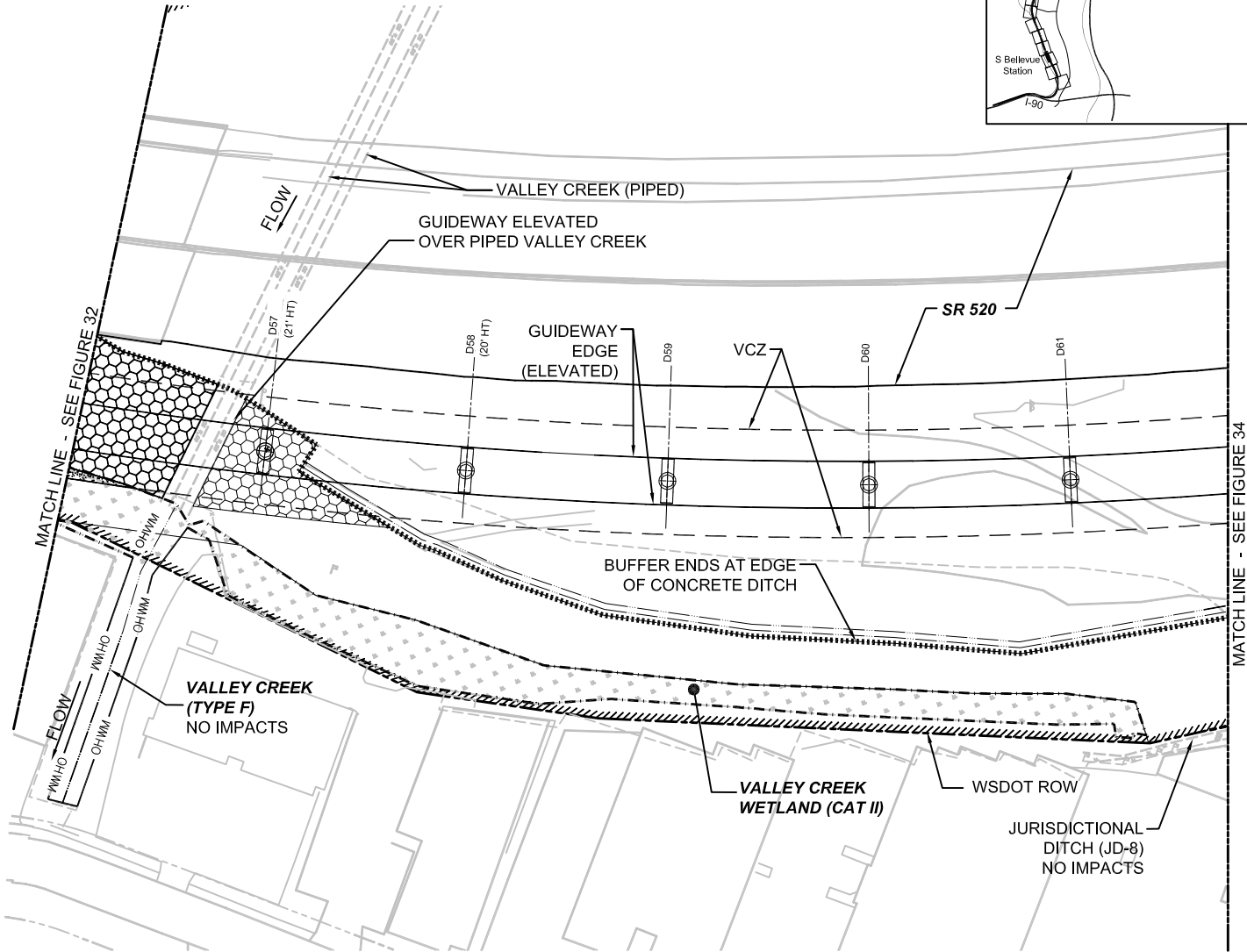
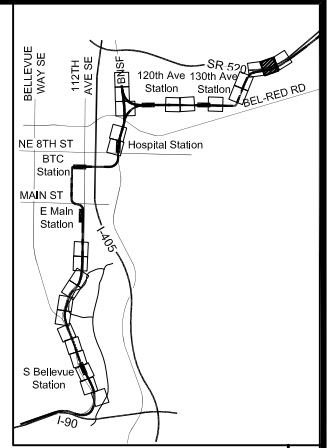

LEGEND

- TEMPORARY BUFFER IMPACT
- PERMANENT BUFFER IMPACT
- WETLAND VEGETATION CONVERSION IMPACT
- EXISTING WETLAND
- EXISTING WETLAND BUFFER
- ORDINARY HIGH WATER MARK (OHWM)
- VEGETATION CLEAR ZONE (VCZ)

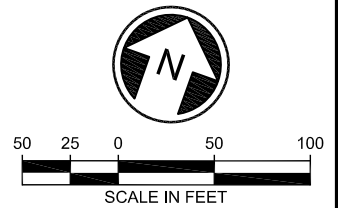

05/05/15 | 2:59 PM | JLOGAN | J:\5229\CADD\DS001\DRAWINGS\ARCH\CRITICAL AREAS REPORT\IMPACTS\E360L88-CARB.DWG



**EAST LINK EXTENSION
SOUTH BELLEVUE TO OVERLAKE TRANSIT CENTER
APPENDIX B
FIGURE 33
WETLAND, STREAM, AND BUFFER IMPACTS**

Appendix C

Wetland, Stream, and Buffer Mitigation Plans

NOTES:

1. REFER TO FIGURES 1 TO 12 IN APPENDIX D FOR PLANTING PLANS.
2. THIS SHEET IS FOR REFERENCE OF ENLARGED FIGURES (SEE FIGURES 2-5, APPENDIX C)
3. SHORELINE CRITICAL AREA BUFFER MITIGATION IS FULLY CAPTURED WITHIN PROPOSED WETLAND / STREAM BUFFER MITIGATION.

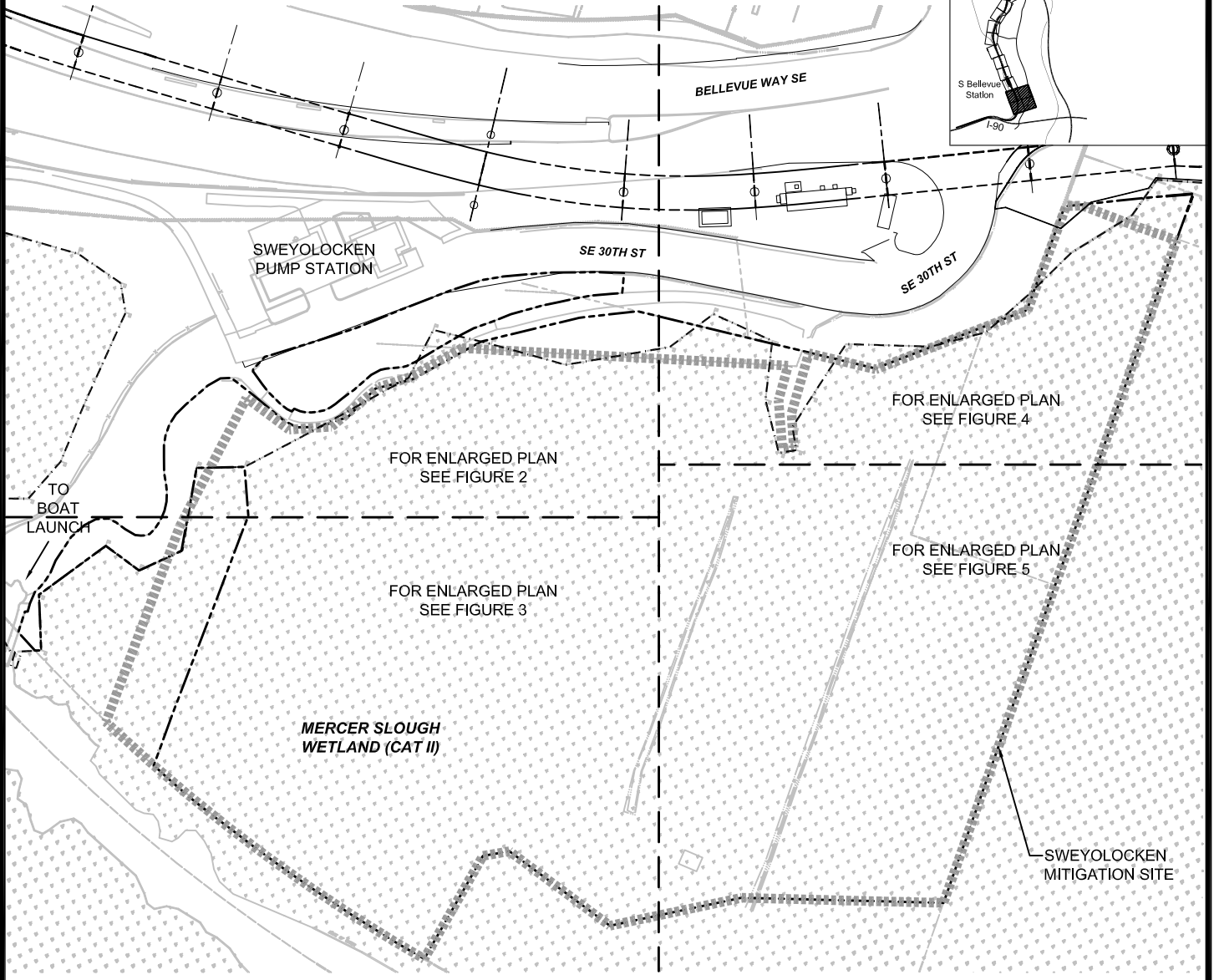
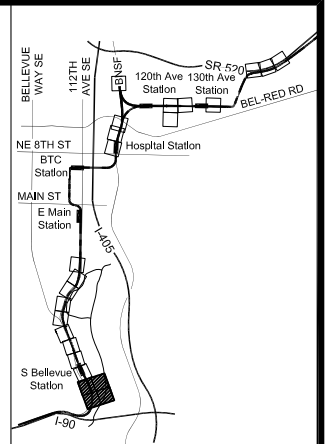

N.T.S.

05/06/15 | 9:14 AM | JLOGAN | J:\55229\CADD\5001\DRAWINGS\ARCH\CRITICAL AREAS REPORT\MITIGATION\8.5X11E320-L85-CAR201.DWG



EAST LINK EXTENSION
SOUTH BELLEVUE TO OVERLAKE TRANSIT CENTER
 APPENDIX C
 FIGURE 1
 WETLAND, STREAM, AND BUFFER MITIGATION PLANS

NAME	RESTORATION	ENHANCEMENT	REHABILITATION
MERCER SLOUGH WETLAND	0.36 ACRE	NA	NA
MERCER SLOUGH WETLAND BUFFER	2.75 ACRES	NA	NA
SWEYOLOCKEN	NA	4.87 ACRES (WETLAND) 0.85 ACRE (BUFFER)	1.50 ACRES

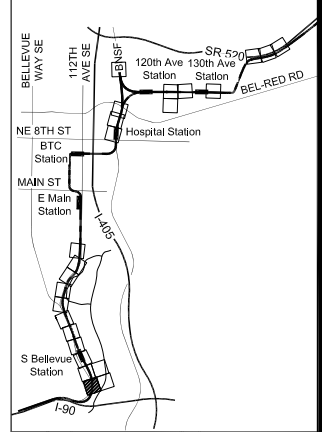

NOTES:

- REFER TO FIGURES 1 TO 12 IN APPENDIX D FOR PLANTING PLANS.
- VALUES REPRESENT RESTORATION OR MITIGATION TO ENTIRE AREA, NOT JUST AREA SHOWN ON THIS SHEET.
- SHORELINE CRITICAL AREA BUFFER MITIGATION IS FULLY CAPTURED WITHIN PROPOSED WETLAND / STREAM BUFFER MITIGATION.

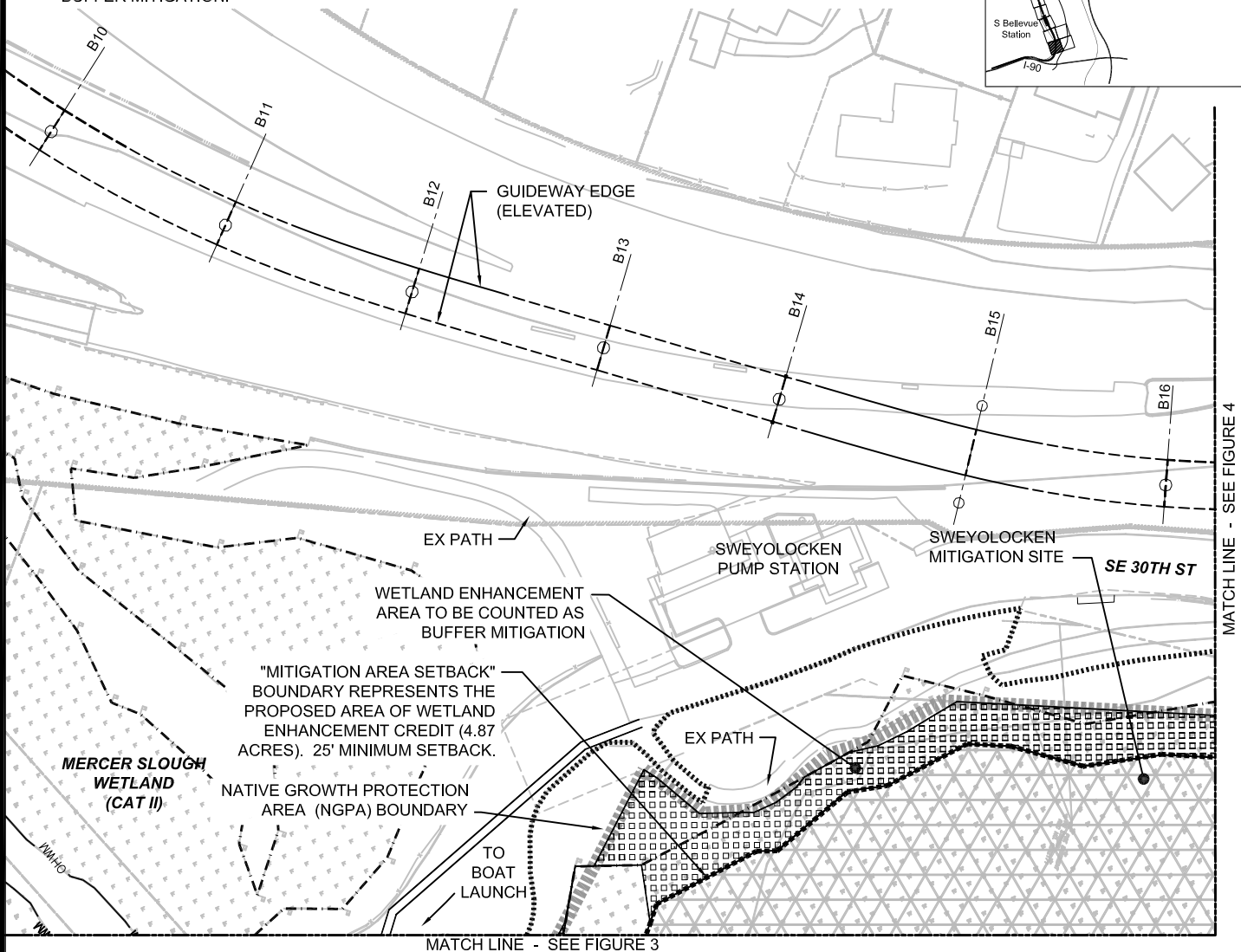

LEGEND

- WETLAND ENHANCEMENT
- BUFFER ENHANCEMENT/CREATION
- WETLAND
- WETLAND BUFFER
- OHWM — ORDINARY HIGH WATER MARK
- NGPA

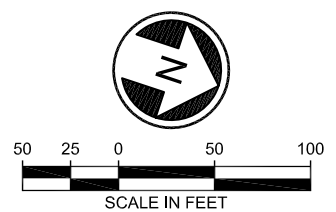

05/06/15 | 9:14 AM | J.LOGAN | J:\55229\CADD\5001\DRAWINGS\ARCH\CRITICAL AREAS REPORT\MITIGATION\8.5X11E320-L85-CAR201.DWG



EAST LINK EXTENSION
SOUTH BELLEVUE TO OVERLAKE TRANSIT CENTER
 APPENDIX C
 FIGURE 2
 WETLAND, STREAM, AND BUFFER MITIGATION PLANS

NAME	RESTORATION	ENHANCEMENT	REHABILITATION
MERCER SLOUGH WETLAND	0.36 ACRE	NA	NA
MERCER SLOUGH WETLAND BUFFER	2.75 ACRES	NA	NA
SWEYOLOCKEN	NA	4.87 ACRES (WETLAND) 0.85 ACRE (BUFFER)	1.50 ACRES

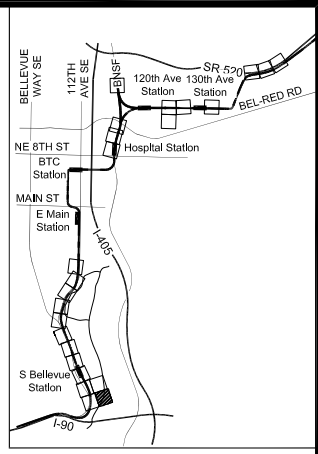

NOTES:

1. REFER TO FIGURES 1 TO 12 IN APPENDIX D FOR PLANTING PLANS.
2. VALUES REPRESENT RESTORATION OR MITIGATION TO ENTIRE AREA, NOT JUST AREA SHOWN ON THIS SHEET.
3. SHORELINE CRITICAL AREA BUFFER MITIGATION IS FULLY CAPTURED WITHIN PROPOSED WETLAND / STREAM BUFFER MITIGATION.
4. WHEN STREAM AND WETLAND BUFFERS OVERLAP THEY WILL BE SHOWN AS WETLAND BUFFERS.

MATCH LINE - SEE FIGURE 2

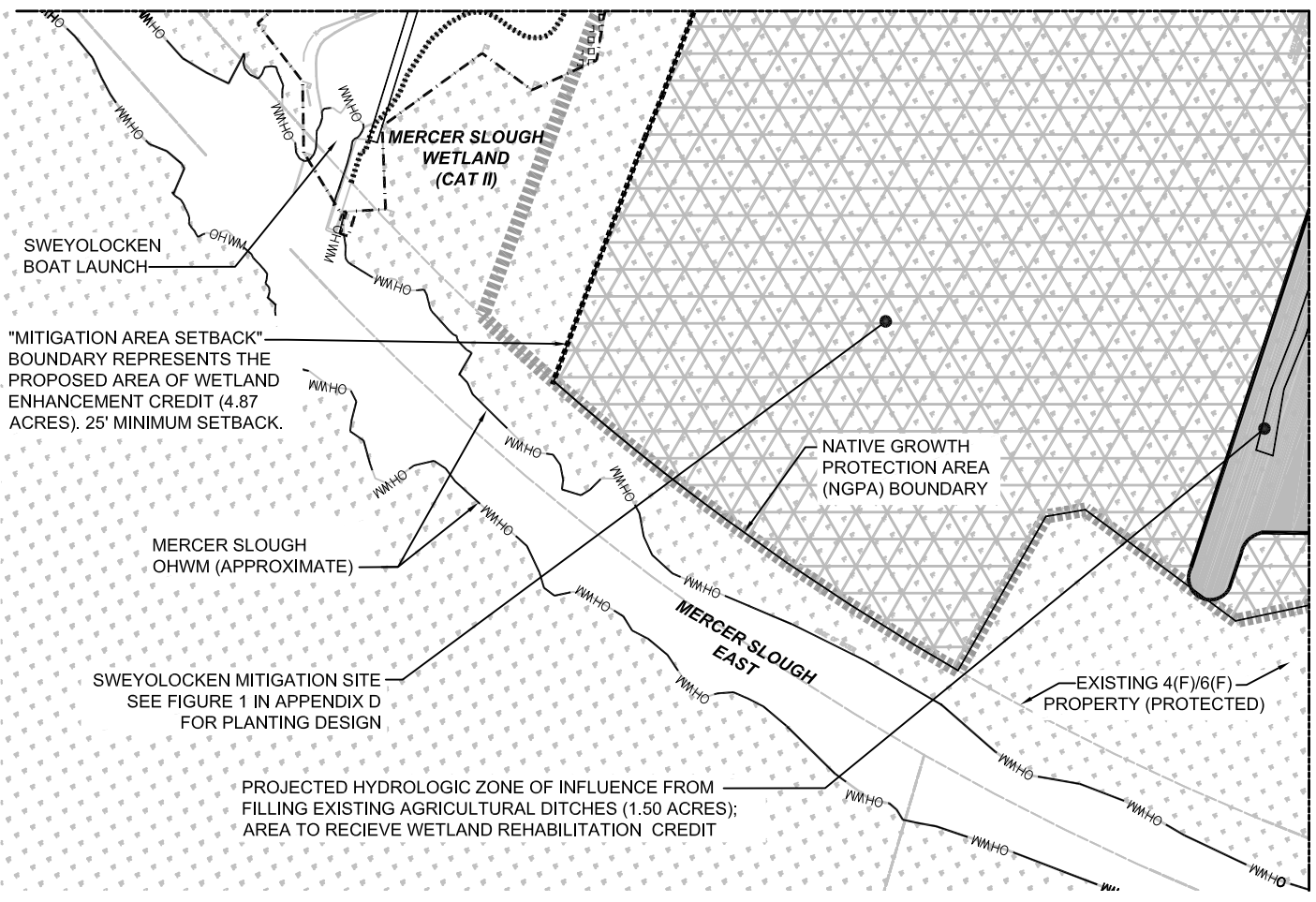

MATCH LINE - SEE FIGURE 5

LEGEND

- WETLAND ENHANCEMENT
- BUFFER ENHANCEMENT/CREATION
- WETLAND
- WETLAND BUFFER
- ORDINARY HIGH WATER MARK
- NGPA

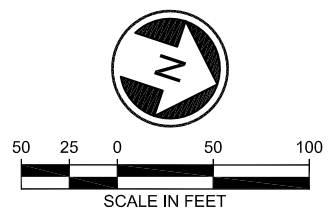

05/06/15 | 9:14 AM | JLOGAN J:\55229\CADD\5001\DRAWINGS\ARCH\CRITICAL AREAS REPORT\MITIGATION8.5X11\E320-L85-CAR201.DWG



EAST LINK EXTENSION
SOUTH BELLEVUE TO OVERLAKE TRANSIT CENTER
 APPENDIX C
 FIGURE 3
 WETLAND, STREAM, AND BUFFER MITIGATION PLANS

NAME	RESTORATION	ENHANCEMENT	REHABILITATION
MERCER SLOUGH WETLAND	0.36 ACRE	NA	NA
MERCER SLOUGH WETLAND BUFFER	2.75 ACRES	NA	NA
SWEYOLOCKEN	NA	4.87 ACRES (WETLAND) 0.85 ACRE (BUFFER)	1.50 ACRES

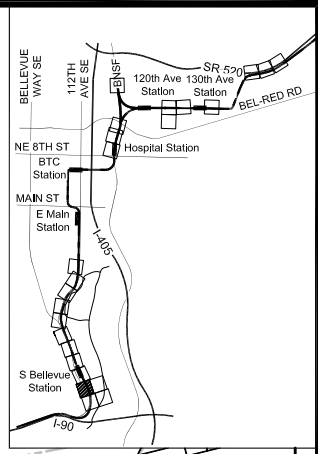

NOTES:

1. REFER TO FIGURES 1 TO 12 IN APPENDIX D FOR PLANTING PLANS.
2. VALUES REPRESENT RESTORATION OR MITIGATION TO ENTIRE AREA, NOT JUST AREA SHOWN ON THIS SHEET.
3. SHORELINE CRITICAL AREA BUFFER MITIGATION IS FULLY CAPTURED WITHIN PROPOSED WETLAND / STREAM BUFFER MITIGATION.

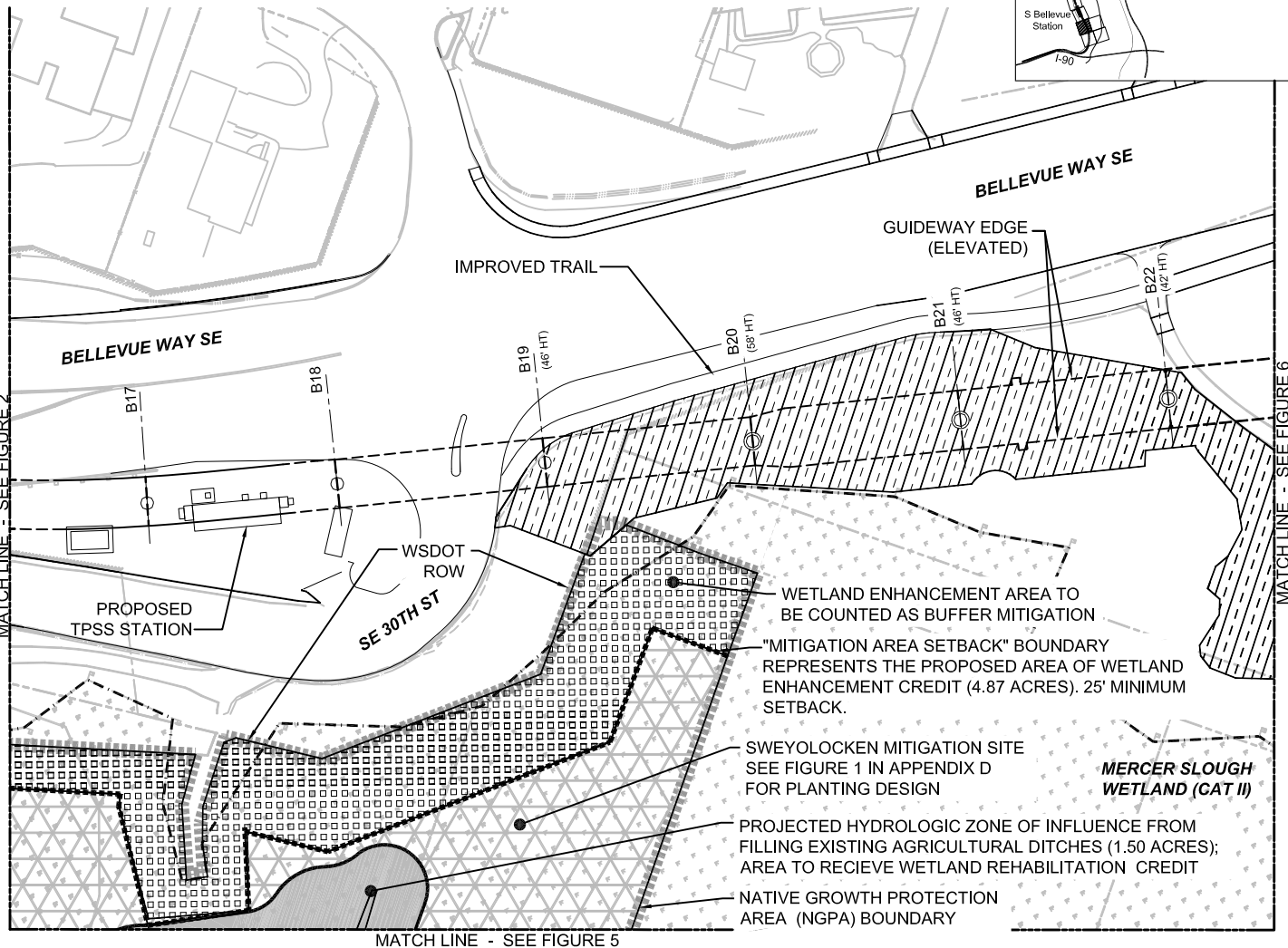

LEGEND

- BUFFER RESTORATION
- WETLAND ENHANCEMENT
- BUFFER ENHANCEMENT/CREATION
- WETLAND
- WETLAND BUFFER
- OHWM — ORDINARY HIGH WATER MARK
- NGPA

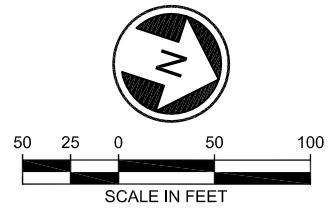

05/06/15 | 9:15 AM | JLOGAN J:\55229\CADD\5001\DRAWINGS\ARCH\CRITICAL AREAS REPORT\MITIGATION\8.5X11\E320-L85-CAR201.DWG



EAST LINK EXTENSION
SOUTH BELLEVUE TO OVERLAKE TRANSIT CENTER
 APPENDIX C
 FIGURE 4
 WETLAND, STREAM, AND BUFFER MITIGATION PLANS

NAME	RESTORATION	ENHANCEMENT	REHABILITATION
MERCER SLOUGH WETLAND	0.36 ACRE	NA	NA
MERCER SLOUGH WETLAND BUFFER	2.75 ACRES	NA	NA
SWEYOLOCKEN	NA	4.87 ACRES (WETLAND) 0.85 ACRE (BUFFER)	1.50 ACRES

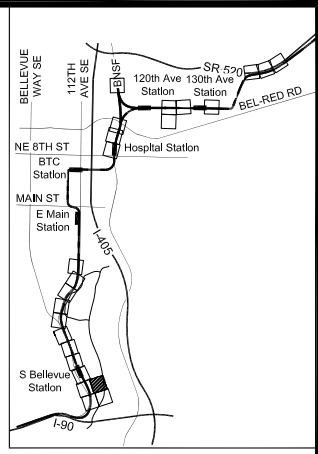

NOTES:

1. REFER TO FIGURES 1 TO 12 IN APPENDIX D FOR PLANTING PLANS.
2. VALUES REPRESENT RESTORATION OR MITIGATION TO ENTIRE AREA, NOT JUST AREA SHOWN ON THIS SHEET.
3. SHORELINE CRITICAL AREA BUFFER MITIGATION IS FULLY CAPTURED WITHIN PROPOSED WETLAND / STREAM BUFFER MITIGATION.
4. WHEN STREAM AND WETLAND BUFFERS OVERLAP THEY WILL BE SHOWN AS WETLAND BUFFERS.

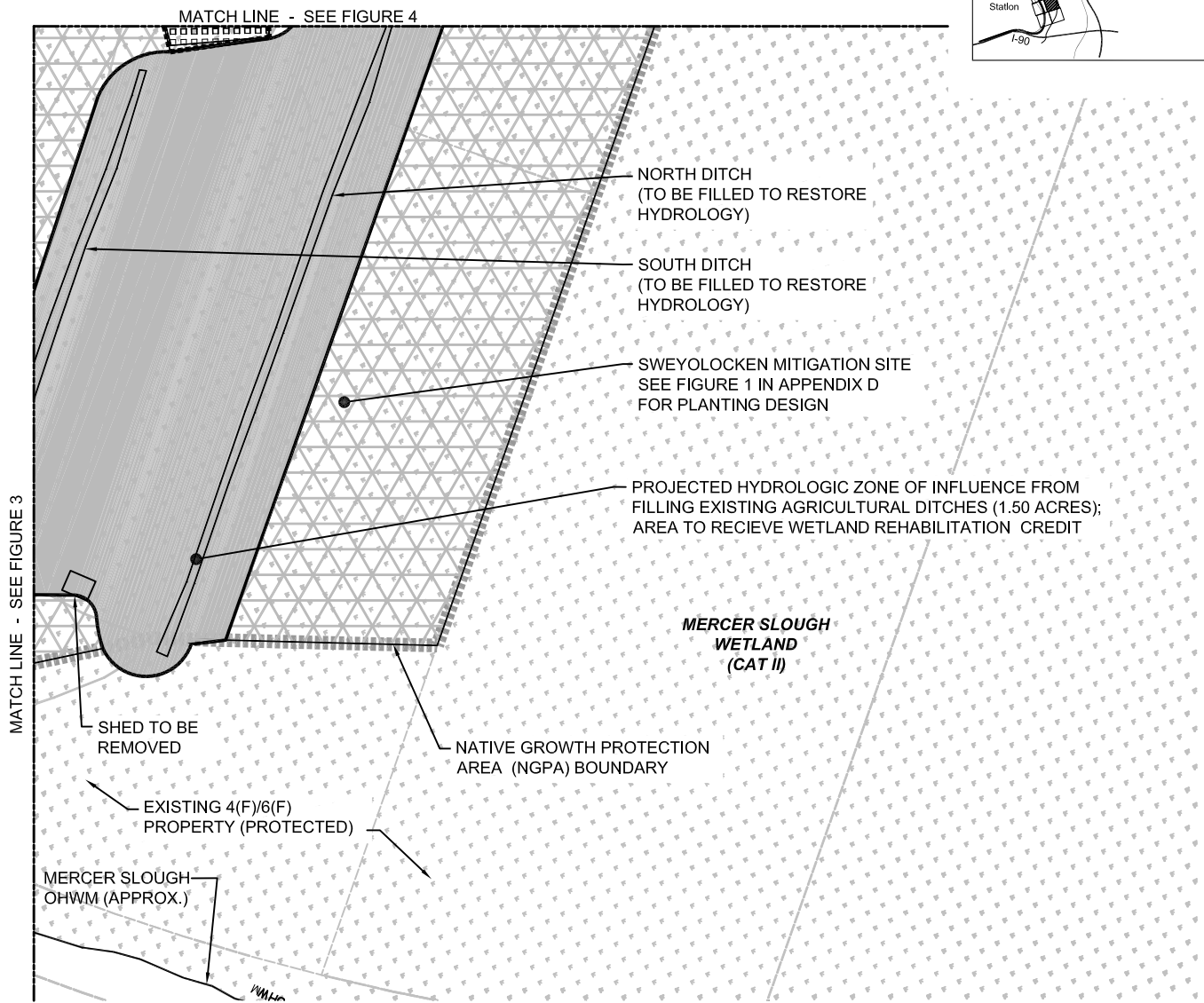

LEGEND

- WETLAND ENHANCEMENT
- BUFFER ENHANCEMENT/CREATION
- WETLAND
- WETLAND BUFFER
- OHWM — ORDINARY HIGH WATER MARK
- NGPA

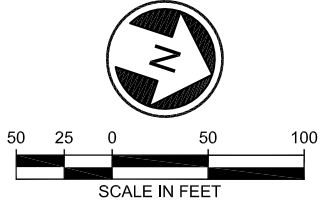

05/06/15 | 9:15 AM | JLOGAN J:\55229\CADD\55001\DRAWINGS\ARCH\CRITICAL AREAS REPORT\MITIGATION\8.5X11E320-L85-CAR201.DWG

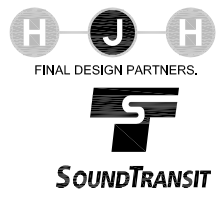

EAST LINK EXTENSION
SOUTH BELLEVUE TO OVERLAKE TRANSIT CENTER
 APPENDIX C
 FIGURE 5
 WETLAND, STREAM, AND BUFFER MITIGATION PLANS



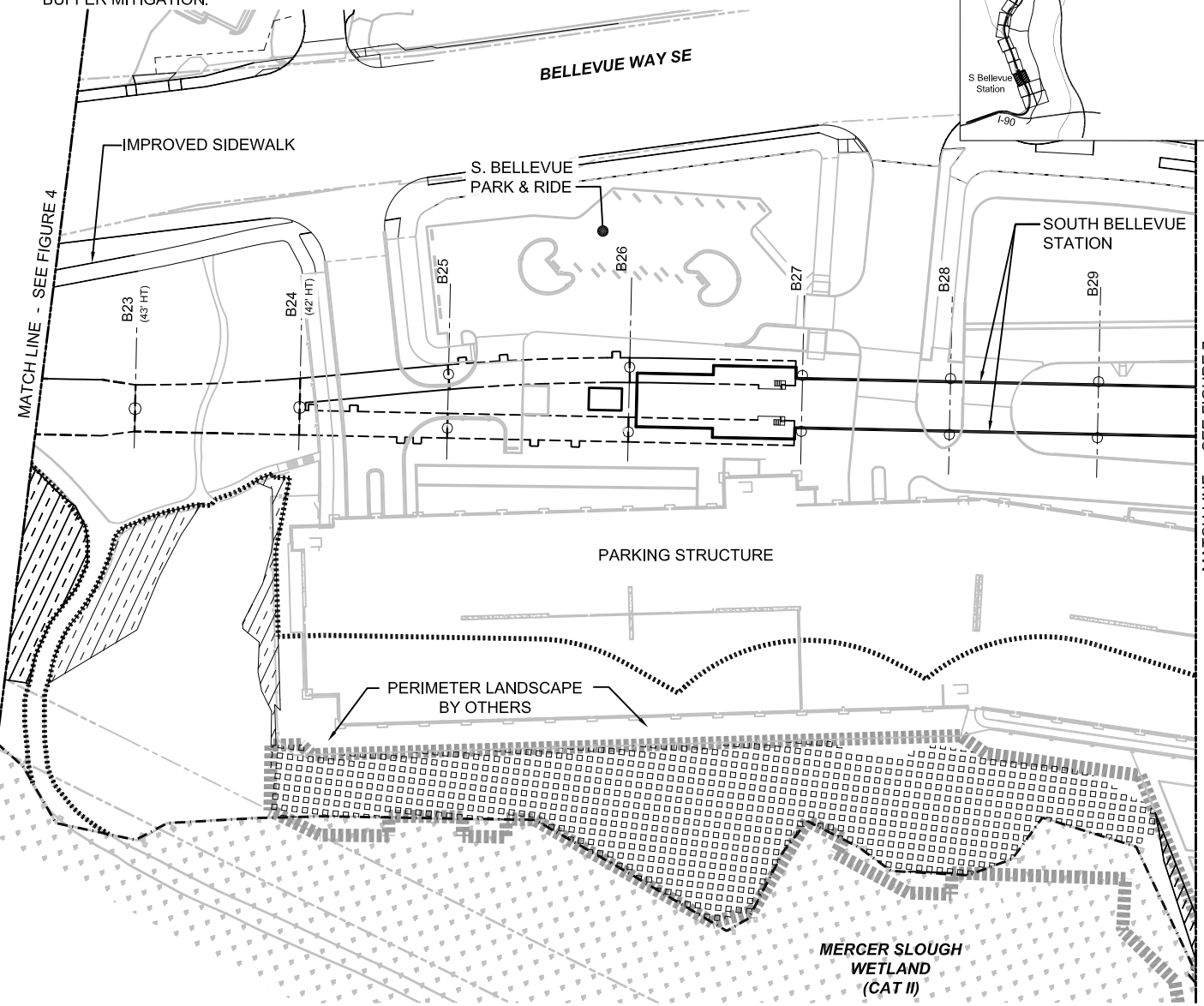

NAME	RESTORATION	ENHANCEMENT
MERCER SLOUGH WETLAND	0.36 ACRE	NA
MERCER SLOUGH WETLAND BUFFER	2.75 ACRES	NA
M.S. BUFFER CREATION/ENHANCEMENT	NA	3.38 ACRES

NOTES:

1. REFER TO FIGURES 1 TO 12 IN APPENDIX D FOR PLANTING PLANS.
2. VALUES REPRESENT RESTORATION OR MITIGATION TO ENTIRE AREA, NOT JUST AREA SHOWN ON THIS SHEET.
3. SHORELINE CRITICAL AREA BUFFER MITIGATION IS FULLY CAPTURED WITHIN PROPOSED WETLAND / STREAM BUFFER MITIGATION.

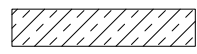
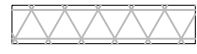
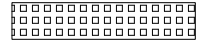

LEGEND

-  BUFFER RESTORATION
-  WETLAND ENHANCEMENT
-  BUFFER ENHANCEMENT/CREATION
-  WETLAND
-  WETLAND BUFFER
-  NGPA

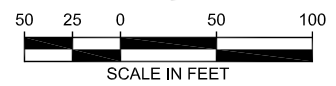

MATCH LINE - SEE FIGURE 4

MATCH LINE - SEE FIGURE 7

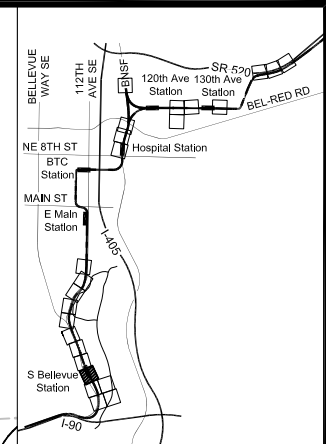

05/06/15 | 9:16 AM | JLOGAN | J:\55229\CADD\55001\DRAWINGS\ARCH\CRITICAL AREAS REPORT\MITIGATION\8.5X11E320-L85-CAR201.DWG



SOUNDTRANSIT

EAST LINK EXTENSION
SOUTH BELLEVUE TO OVERLAKE TRANSIT CENTER
 APPENDIX C
 FIGURE 6
 WETLAND, STREAM, AND BUFFER MITIGATION PLANS



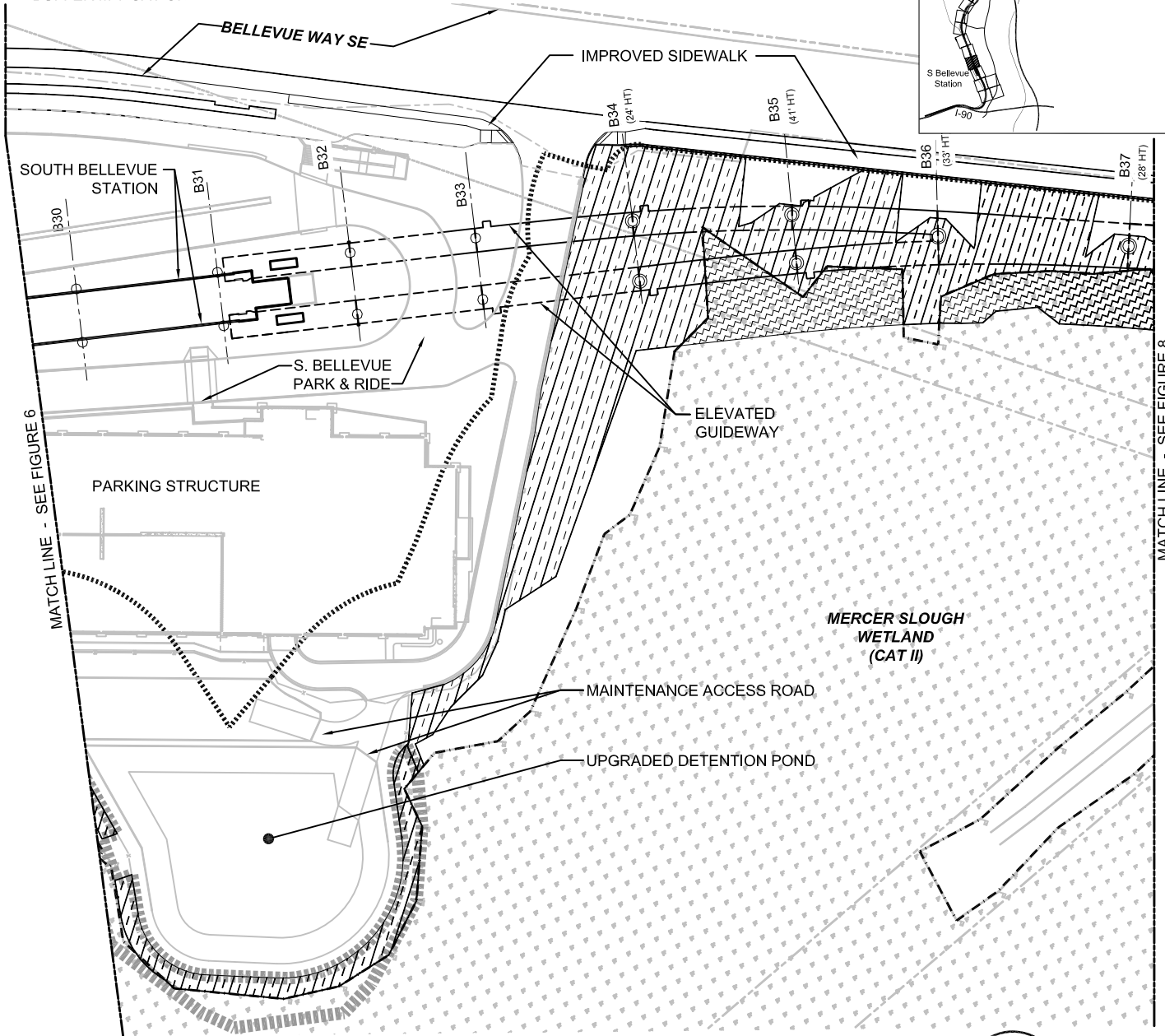
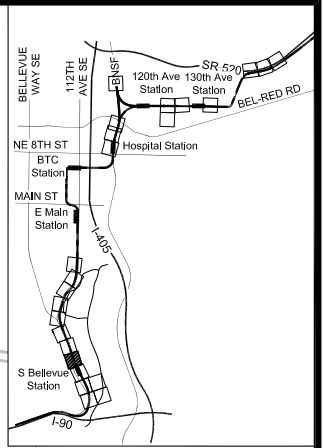

NAME	RESTORATION	ENHANCEMENT
MERCER SLOUGH WETLAND	0.36 ACRE	NA
MERCER SLOUGH WETLAND BUFFER	2.75 ACRES	NA

NOTES:

1. REFER TO FIGURES 1 TO 12 IN APPENDIX D FOR PLANTING PLANS.
2. VALUES REPRESENT RESTORATION OR MITIGATION TO ENTIRE AREA, NOT JUST AREA SHOWN ON THIS SHEET.
3. SHORELINE CRITICAL AREA BUFFER MITIGATION IS FULLY CAPTURED WITHIN PROPOSED WETLAND / STREAM BUFFER MITIGATION.

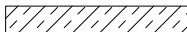

LEGEND

-  BUFFER RESTORATION
-  WETLAND RESTORATION
-  WETLAND
-  WETLAND BUFFER
-  NGPA

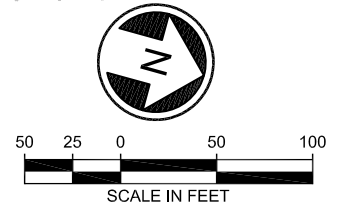

05/06/15 | 9:16 AM | JLOGAN J:\65229\CADD\5001\DRAWINGS\ARCH\CRITICAL AREAS REPORT\MITIGATION\8.5X11E320-L85-CAR201.DWG



EAST LINK EXTENSION
SOUTH BELLEVUE TO OVERLAKE TRANSIT CENTER
 APPENDIX C
 FIGURE 7
 WETLAND, STREAM, AND BUFFER MITIGATION PLANS

NAME	RESTORATION
MERCER SLOUGH WETLAND	0.36 ACRE
MERCER SLOUGH WETLAND BUFFER	2.75 ACRES

NOTES:

1. REFER TO FIGURES 1 TO 12 IN APPENDIX D FOR PLANTING PLANS.
2. VALUES REPRESENT RESTORATION OR MITIGATION TO ENTIRE AREA, NOT JUST AREA SHOWN ON THIS SHEET.
3. SHORELINE CRITICAL AREA BUFFER MITIGATION IS FULLY CAPTURED WITHIN PROPOSED WETLAND / STREAM BUFFER MITIGATION.

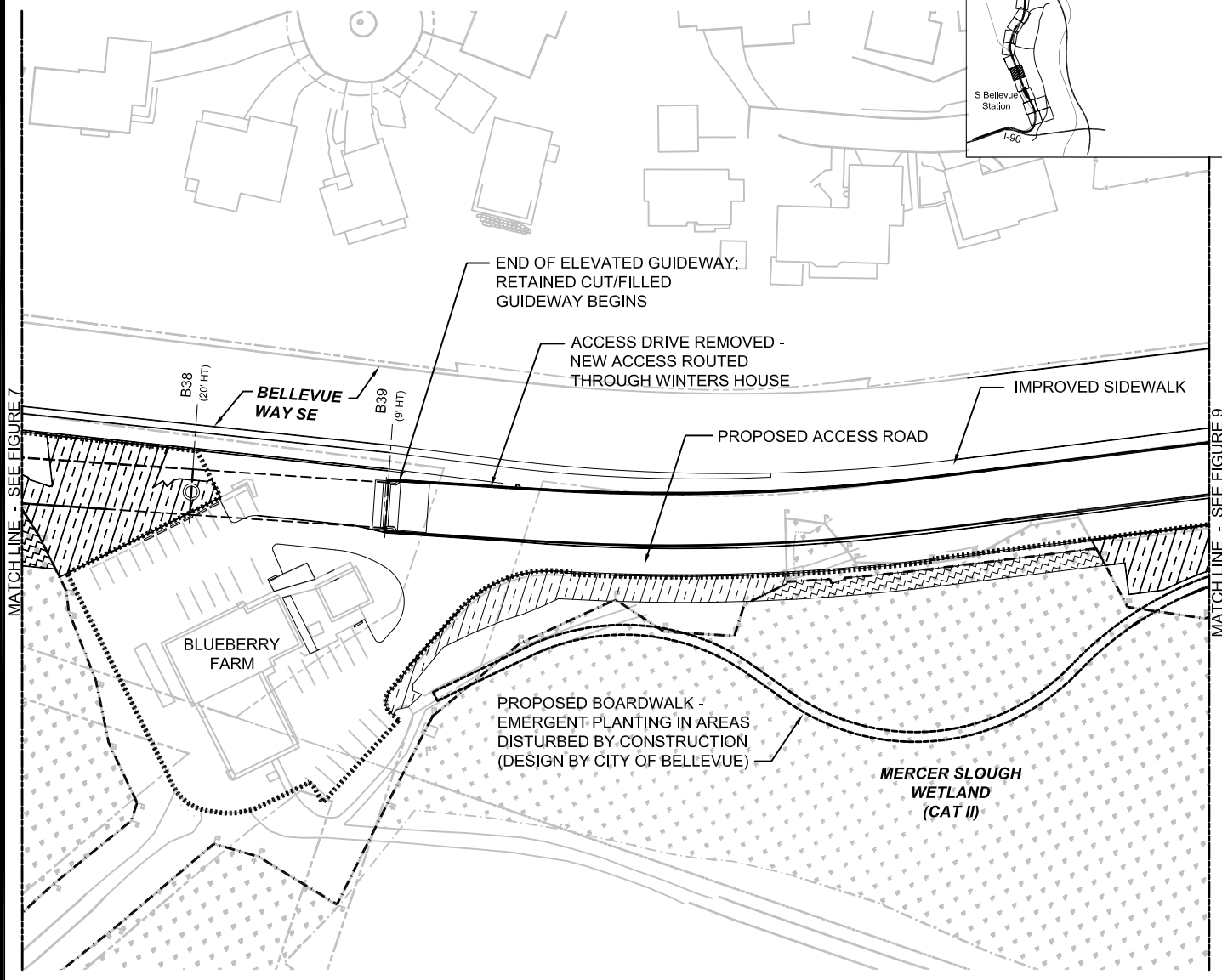
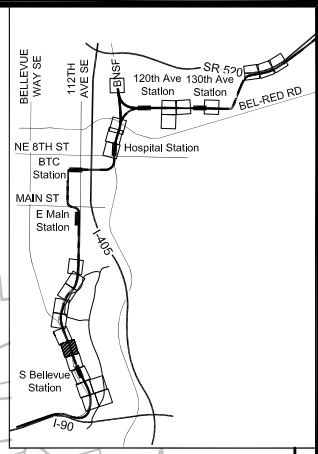

MATCH LINE - SEE FIGURE 7

MATCH LINE - SEE FIGURE 9

LEGEND

- BUFFER RESTORATION
- WETLAND RESTORATION
- WETLAND
- WETLAND BUFFER

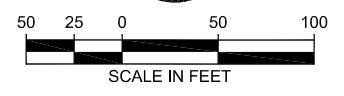

05/06/15 | 9:17 AM | JLOGAN
J:\55229\CADD\55001\DRAWINGS\ARCH\CRITICAL AREAS REPORT\MITIGATION\8.5X11\E320-L85-CAR201.DWG

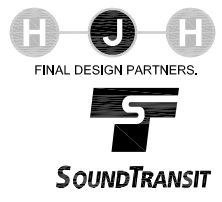

EAST LINK EXTENSION
SOUTH BELLEVUE TO OVERLAKE TRANSIT CENTER
 APPENDIX C
 FIGURE 8
 WETLAND, STREAM, AND BUFFER MITIGATION PLANS

NAME	RESTORATION	ENHANCEMENT
MERCER SLOUGH WETLAND	0.36 ACRE	NA
MERCER SLOUGH WETLAND BUFFER	2.75 ACRES	NA
WYE CREEK	527 SF ^a	NA
WYE CREEK BUFFER	0.40 ACRE	NA

a. 62 SF IS DAYLIGHTING THAT APPLIES TO MITIGATION FOR SHADING IMPACTS TO ALCOVE CREEK. THE REMAINING 465 SF APPLIES TO STREAM CHANNEL IMPROVEMENTS. 420 SF OF RESTORATION APPLIES TO WYE CREEK IMPACTS AND 45 SF OF RESTORATION APPLIES TO ALCOVE CREEK SHADING IMPACTS.

NOTES:

- REFER TO FIGURES 1 TO 12 IN APPENDIX D FOR PLANTING PLANS.
- VALUES REPRESENT RESTORATION OR MITIGATION TO ENTIRE AREA, NOT JUST AREA SHOWN ON THIS SHEET.
- SHORELINE CRITICAL AREA BUFFER MITIGATION IS FULLY CAPTURED WITHIN PROPOSED WETLAND / STREAM BUFFER MITIGATION.
- WHEN STREAM AND WETLAND BUFFERS OVERLAP THEY WILL BE SHOWN AS WETLAND BUFFERS.

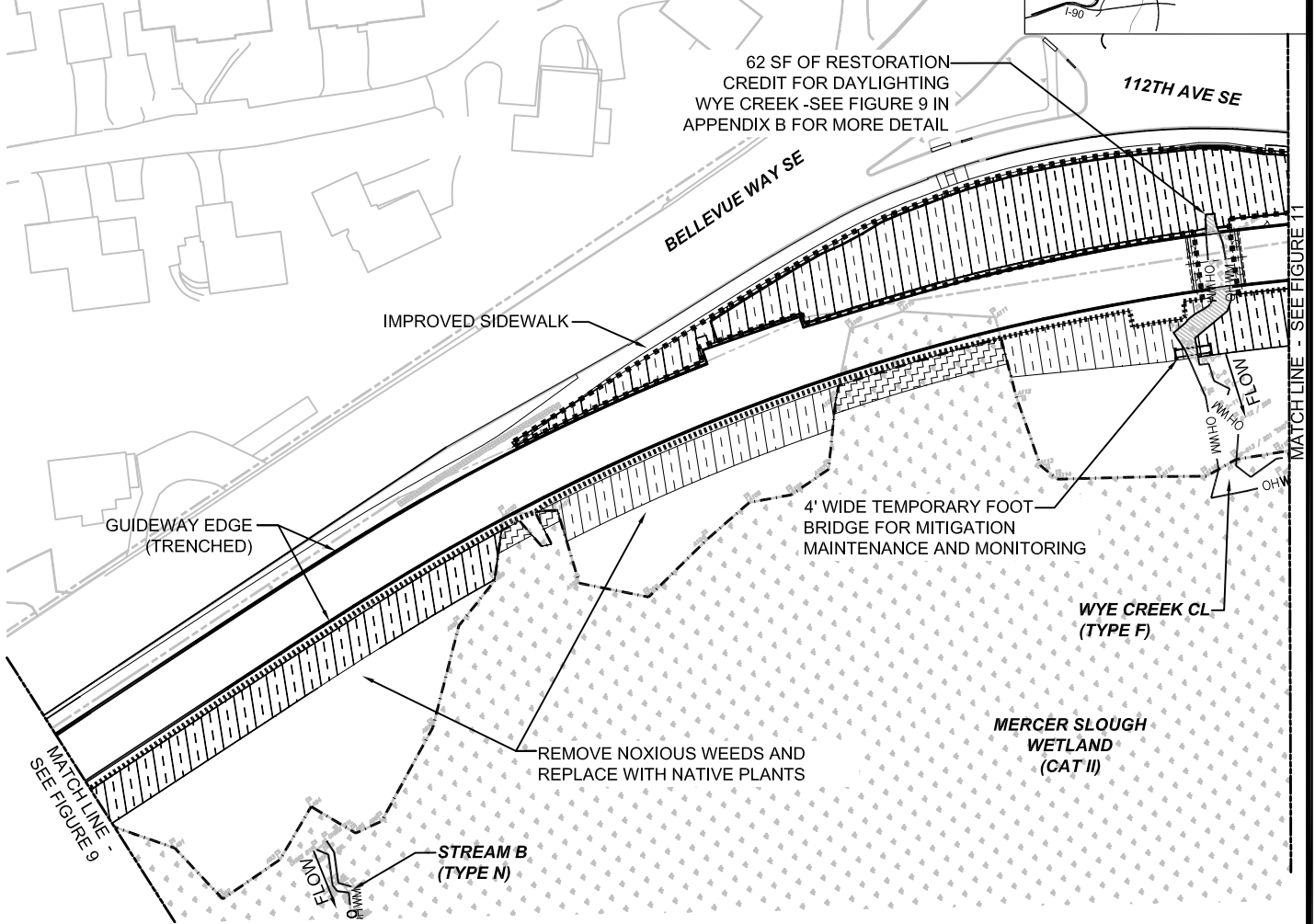
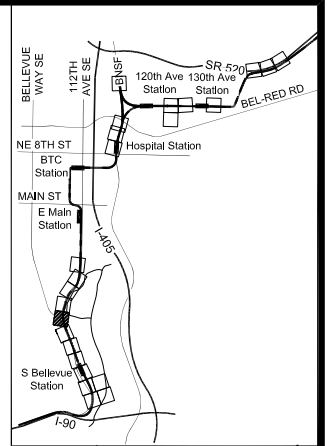

LEGEND

	BUFFER RESTORATION		WETLAND BUFFER
	WETLAND RESTORATION		STREAM BUFFER
	STREAM RESTORATION		OHWM
	WETLAND		ORDINARY HIGH WATER MARK

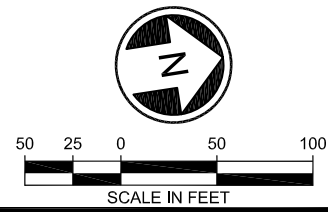

06/05/15 | 1:44 PM | J.JOAN | J:\55229\CADD\5001\DRAWINGS\ARCH\CRITICAL AREAS REPORT\MITIGATION\8.5X11E320-L85-CAR201.DWG



EAST LINK EXTENSION
SOUTH BELLEVUE TO OVERLAKE TRANSIT CENTER
 APPENDIX C
 FIGURE 10
 WETLAND, STREAM, AND BUFFER MITIGATION PLANS

NAME	RESTORATION	ENHANCEMENT
MERCER SLOUGH WETLAND	0.36 ACRE	NA
MERCER SLOUGH WETLAND BUFFER	2.75 ACRES	NA

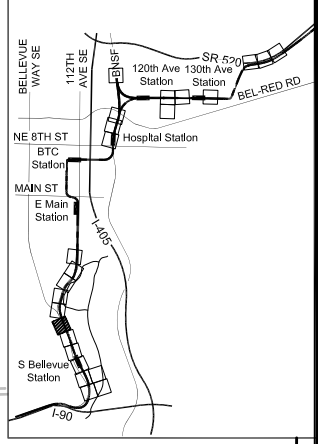

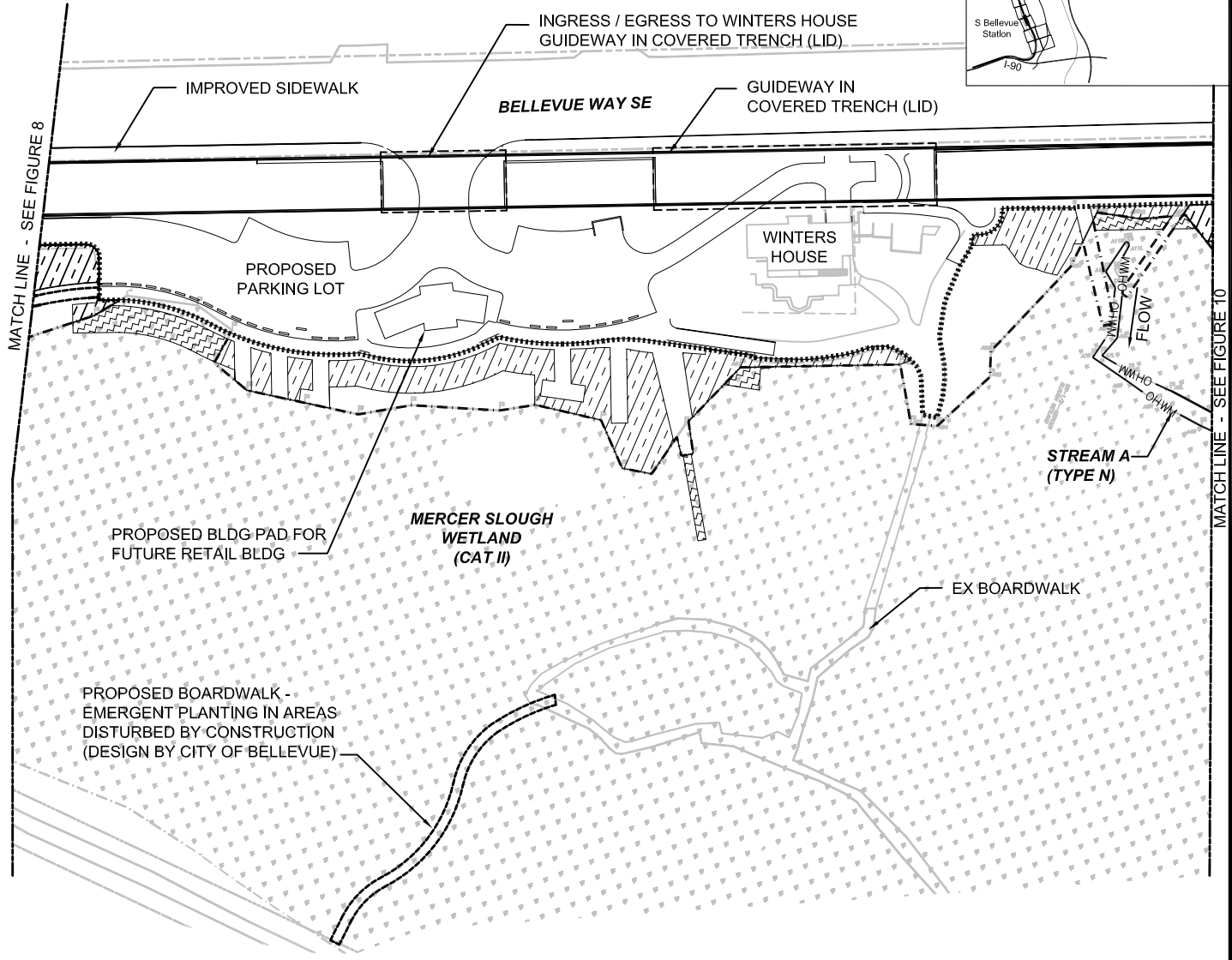

NOTES:

1. REFER TO FIGURES 1 TO 12 IN APPENDIX D FOR PLANTING PLANS.
2. VALUES REPRESENT RESTORATION OR MITIGATION TO ENTIRE AREA, NOT JUST AREA SHOWN ON THIS SHEET.
3. SHORELINE CRITICAL AREA BUFFER MITIGATION IS FULLY CAPTURED WITHIN PROPOSED WETLAND / STREAM BUFFER MITIGATION.
4. WHEN STREAM AND WETLAND BUFFERS OVERLAP THEY WILL BE SHOWN AS WETLAND BUFFERS.

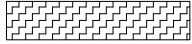

LEGEND

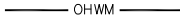
-  BUFFER RESTORATION
-  WETLAND RESTORATION
-  WETLAND
-  WETLAND BUFFER
-  OHWM — ORDINARY HIGH WATER MARK

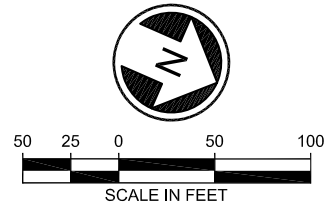

05/06/15 | 9:18 AM | JLOGAN J:\65229\CADD\5001\DRAWINGS\ARCH\CRITICAL AREAS REPORT\MITIGATION8.SX11E520-L85-CAR201.DWG

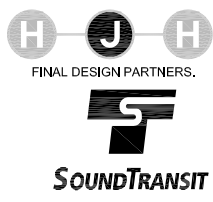

EAST LINK EXTENSION
SOUTH BELLEVUE TO OVERLAKE TRANSIT CENTER
 APPENDIX C
 FIGURE 9
 WETLAND, STREAM, AND BUFFER MITIGATION PLANS

NAME	RESTORATION	ENHANCEMENT
MERCER SLOUGH WETLAND	0.36 ACRE	NA
MERCER SLOUGH WETLAND BUFFER	2.75 ACRES	NA
M.S. BUFFER CREATION/ENHANCEMENT	NA	3.38 ACRES

NOTES:

1. REFER TO FIGURES 1 TO 12 IN APPENDIX D FOR PLANTING PLANS.
2. VALUES REPRESENT RESTORATION OR MITIGATION TO ENTIRE AREA, NOT JUST AREA SHOWN ON THIS SHEET.
3. SHORELINE CRITICAL AREA BUFFER MITIGATION IS FULLY CAPTURED WITHIN PROPOSED WETLAND / STREAM BUFFER MITIGATION.
4. WHEN STREAM AND WETLAND BUFFERS OVERLAP THEY WILL BE SHOWN AS WETLAND BUFFERS.

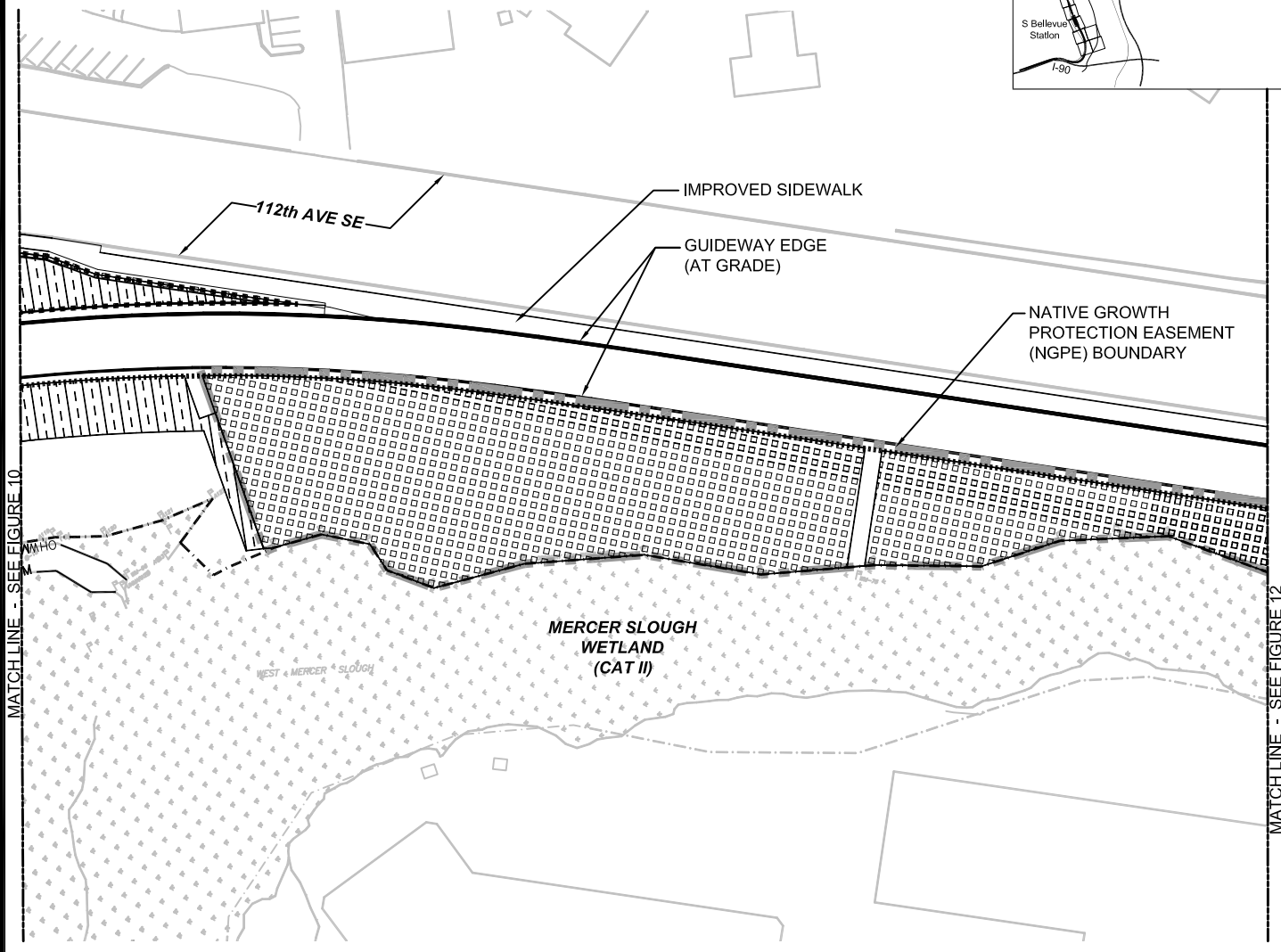
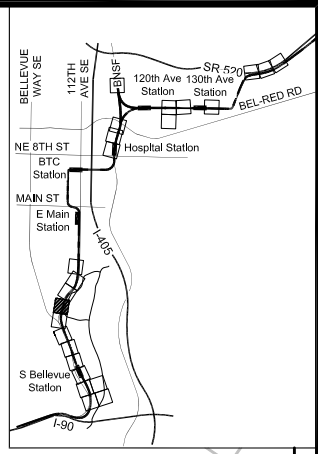

MATCHLINE - SEE FIGURE 10

MATCHLINE - SEE FIGURE 12

LEGEND

- BUFFER RESTORATION
- BUFFER ENHANCEMENT/CREATION
- WETLAND
- WETLAND BUFFER
- STREAM BUFFER
- OHWM
- ORDINARY HIGH WATER MARK
- NGPE

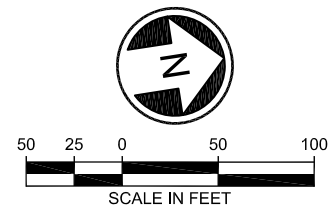

05/06/15 | 9:19 AM | JLOGAN | J:\52229\CADD\5001\DRAWINGS\ARCH\CRITICAL AREAS REPORT\MITIGATION\8.5X11\E320-L85-CAR201.DWG



EAST LINK EXTENSION
SOUTH BELLEVUE TO OVERLAKE TRANSIT CENTER
 APPENDIX C
 FIGURE 11
 WETLAND, STREAM, AND BUFFER MITIGATION PLANS



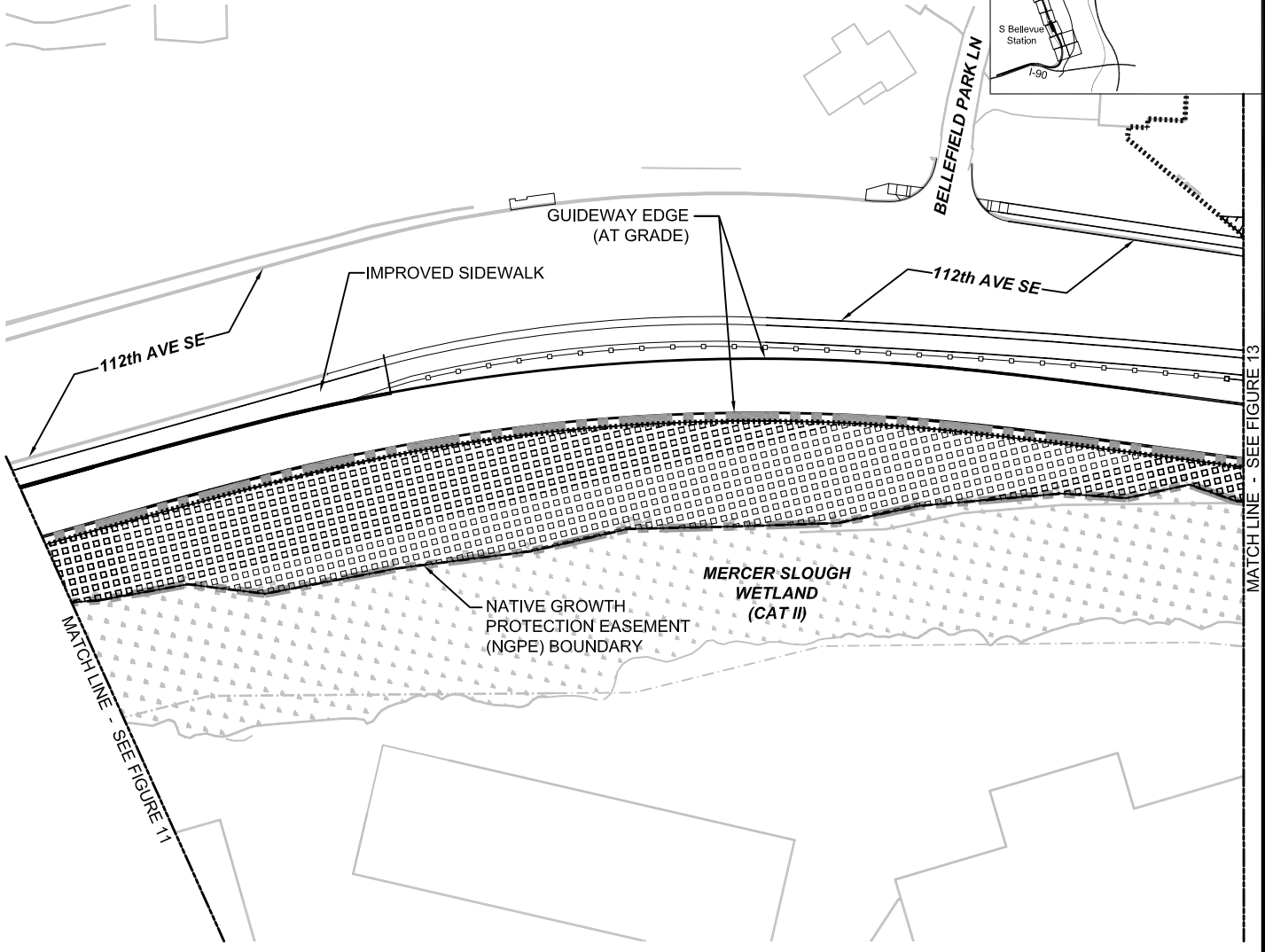
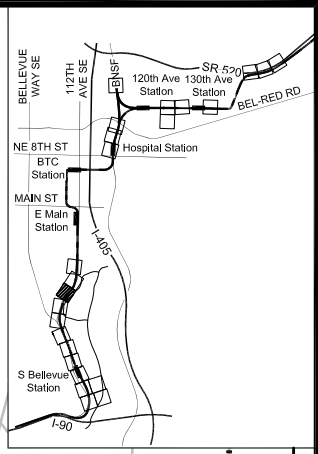

NAME	RESTORATION	ENHANCEMENT
MERCER SLOUGH WETLAND	0.36 ACRE	NA
MERCER SLOUGH WETLAND BUFFER	2.75 ACRES	NA
M.S. BUFFER CREATION/ENHANCEMENT	NA	3.38 ACRES

NOTES:

1. REFER TO FIGURES 1 TO 12 IN APPENDIX D FOR PLANTING PLANS.
2. VALUES REPRESENT RESTORATION OR MITIGATION TO ENTIRE AREA, NOT JUST AREA SHOWN ON THIS SHEET.
3. SHORELINE CRITICAL AREA BUFFER MITIGATION IS FULLY CAPTURED WITHIN PROPOSED WETLAND / STREAM BUFFER MITIGATION.
4. WHEN STREAM AND WETLAND BUFFERS OVERLAP THEY WILL BE SHOWN AS WETLAND BUFFERS.

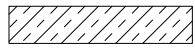
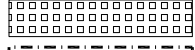

LEGEND

-  BUFFER RESTORATION
-  BUFFER ENHANCEMENT/CREATION
-  WETLAND
-  WETLAND BUFFER
-  NGPE

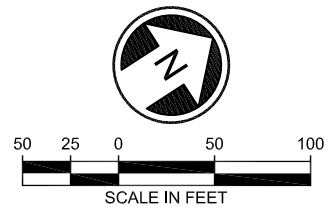

05/06/15 | 9:19 AM | JLOGAN J:\65229\CADD\5001\DRAWINGS\ARCH\CRITICAL AREAS REPORT\MITIGATION\8_SX11E320-L85-CAR201.DWG



EAST LINK EXTENSION
SOUTH BELLEVUE TO OVERLAKE TRANSIT CENTER
 APPENDIX C
 FIGURE 12
 WETLAND, STREAM, AND BUFFER MITIGATION PLANS

NAME	RESTORATION	ENHANCEMENT
MERCER SLOUGH WETLAND	0.36 ACRE	NA
MERCER SLOUGH WETLAND BUFFER	2.75 ACRES	NA
BELLEFIELD SOUTH WETLAND	0.10 ACRE	0.14 ACRE
BELLEFIELD SOUTH WETLAND BUFFER	NA	0.19 ACRE
BELLEFIELD NORTH WETLAND	0.03 ACRE	0.07 ACRE
BELLEFIELD NORTH WETLAND BUFFER	NA	0.19 ACRE
ALCOVE CREEK WETLAND	0.01 ACRE	NA
ALCOVE CREEK WETLAND BUFFER	0.01 ACRE	NA
ALCOVE CREEK	33 SF ^a	NA
M.S. BUFFER CREATION/ENHANCEMENT	NA	3.38 ACRES

a. ADDRESSES RESTORATION OF TEMPORARY IMPACTS.

NOTES:

1. REFER TO FIGURES 1 TO 12 IN APPENDIX D FOR PLANTING PLANS.
2. VALUES REPRESENT RESTORATION OR MITIGATION TO ENTIRE AREA, NOT JUST AREA SHOWN ON THIS SHEET.
3. SHORELINE CRITICAL AREA BUFFER MITIGATION IS FULLY CAPTURED WITHIN PROPOSED WETLAND / STREAM BUFFER MITIGATION.
4. WHEN STREAM AND WETLAND BUFFERS OVERLAP THEY WILL BE SHOWN AS WETLAND BUFFERS.

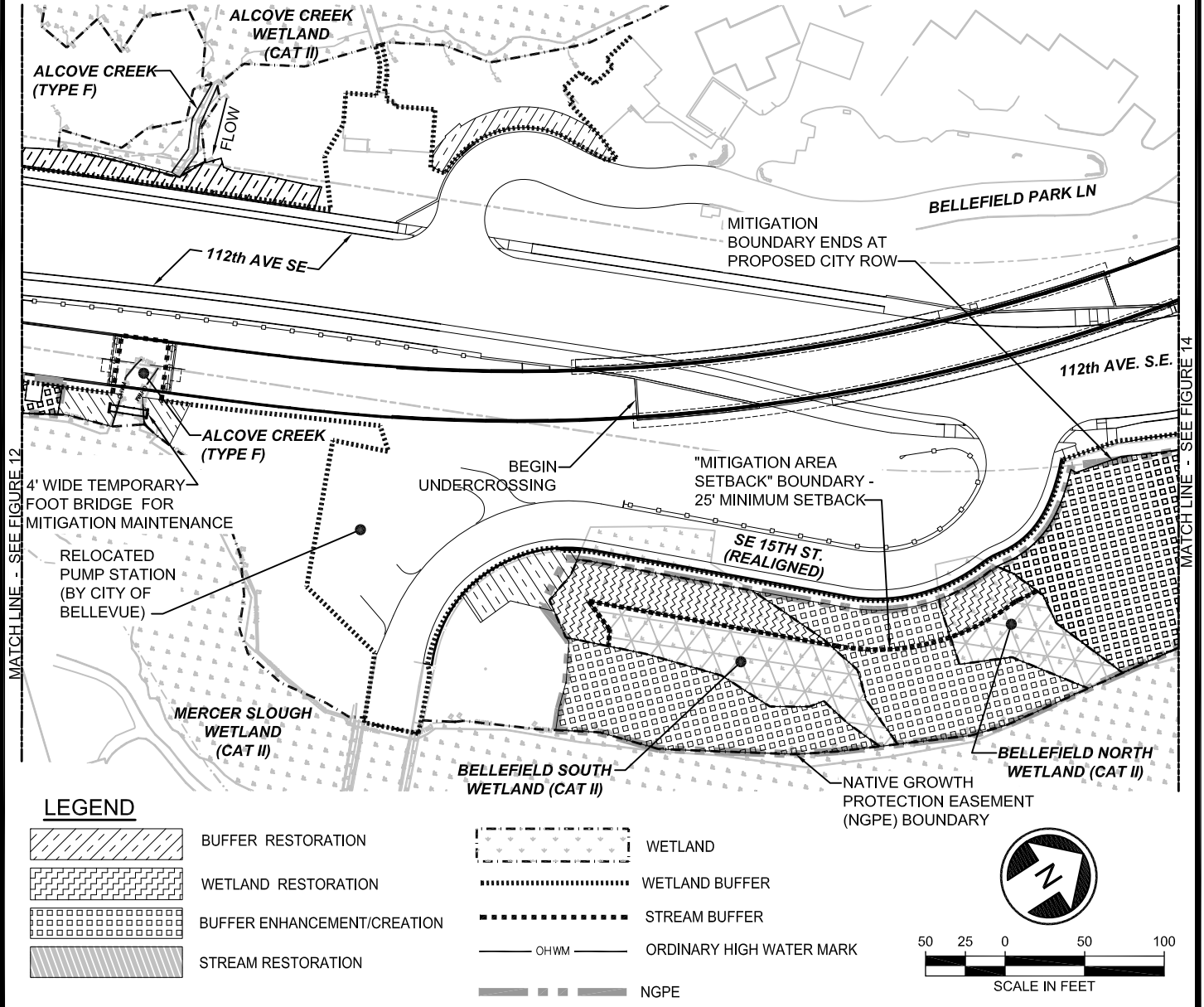
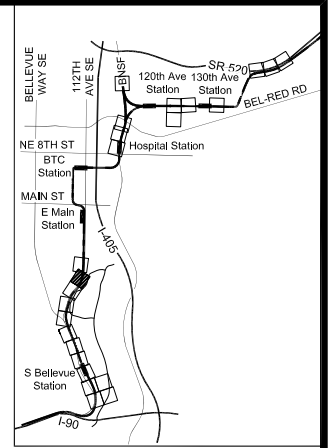

05/06/15 | 9:19 AM | JLOGAN J:\55229\CADD\5001\DRAWINGS\ARCH\CRITICAL AREAS REPORT\MITIGATION\8.5X11E320-L85-CAR201.DWG

MATCH LINE - SEE FIGURE 12

MATCH LINE - SEE FIGURE 14



EAST LINK EXTENSION
SOUTH BELLEVUE TO OVERLAKE TRANSIT CENTER
 APPENDIX C
 FIGURE 13
 WETLAND, STREAM, AND BUFFER MITIGATION PLANS



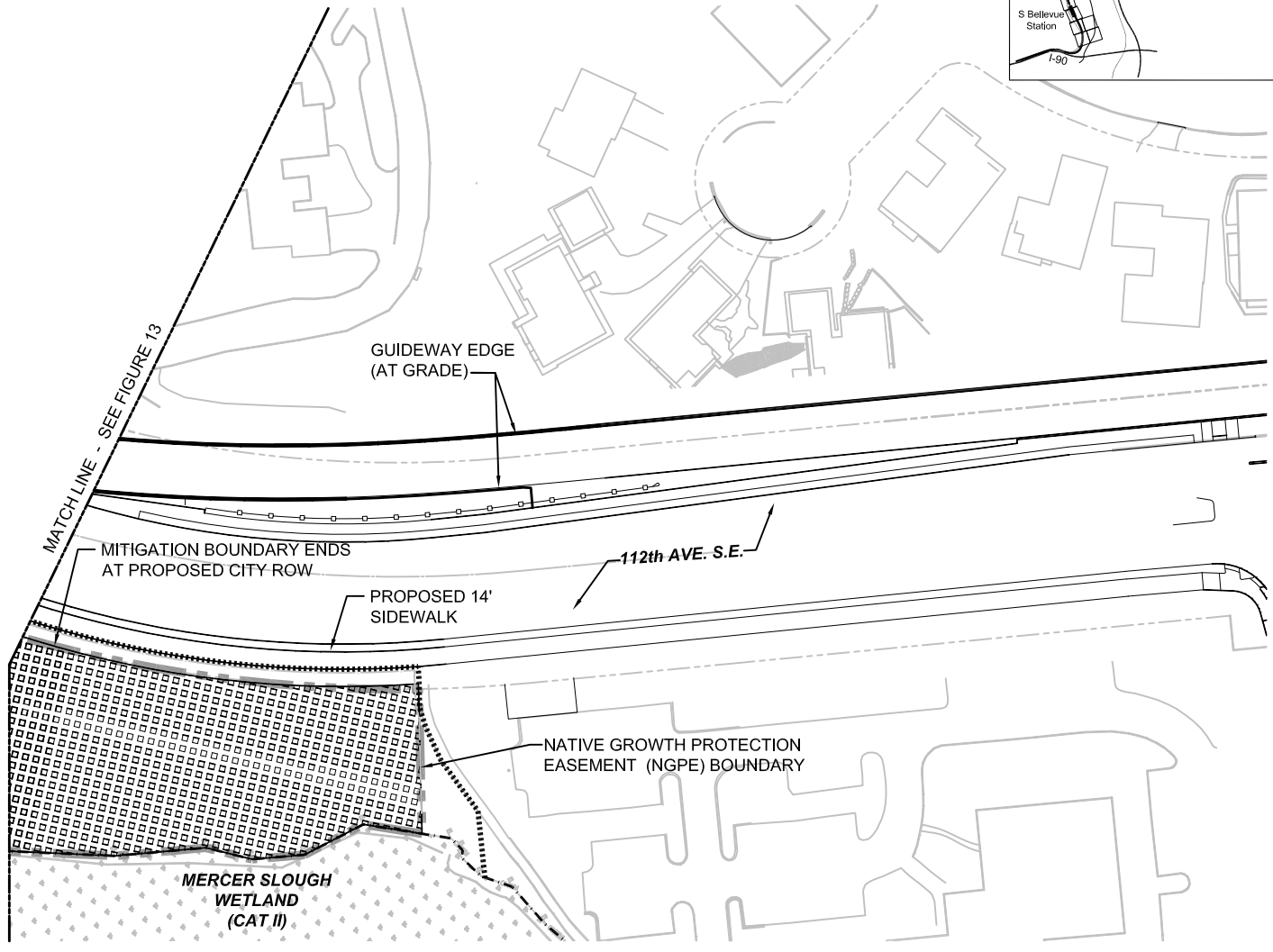
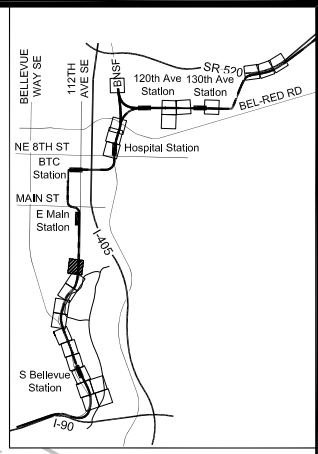

NAME	RESTORATION	ENHANCEMENT
MERCER SLOUGH WETLAND	0.36 ACRE	NA
MERCER SLOUGH WETLAND BUFFER	2.75 ACRES	NA
M.S. BUFFER CREATION/ENHANCEMENT	NA	3.38 ACRES

NOTES:

1. REFER TO FIGURES 1 TO 12 IN APPENDIX D FOR PLANTING PLANS.
2. VALUES REPRESENT RESTORATION OR MITIGATION TO ENTIRE AREA, NOT JUST AREA SHOWN ON THIS SHEET.
3. SHORELINE CRITICAL AREA BUFFER MITIGATION IS FULLY CAPTURED WITHIN PROPOSED WETLAND / STREAM BUFFER MITIGATION.
4. WHEN STREAM AND WETLAND BUFFERS OVERLAP THEY WILL BE SHOWN AS WETLAND BUFFERS.



LEGEND

-  BUFFER ENHANCEMENT/CREATION
-  WETLAND
-  WETLAND BUFFER
-  NGPE

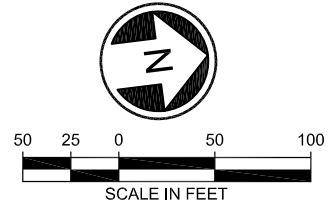

05/06/15 | 9:20 AM | JLOGAN J:\55229\CADD\5001\DRAWINGS\ARCH\CRITICAL AREAS REPORT\MITIGATION\8.5X11\11E320-L85-CAR201.DWG



EAST LINK EXTENSION
SOUTH BELLEVUE TO OVERLAKE TRANSIT CENTER
 APPENDIX C
 FIGURE 14
 WETLAND, STREAM, AND BUFFER MITIGATION PLANS

NAME	RESTORATION (FOR PERMANENT IMPACT)	RESTORATION (FOR TEMPORARY IMPACT)	CREATION
STURTEVANT CREEK	3,500 SF	382 SF	NA
STURTEVANT CREEK BUFFER	0.38 ACRES	NA	0.17 ACRES

NOTES:

1. THIS SHEET IS FOR REFERENCE OF ENLARGED FIGURES (SEE FIGURES 17-20; APPENDIX C)
2. REFER TO FIGURES 1 TO 12 IN APPENDIX D FOR PLANTING PLANS.
3. VALUES REPRESENT RESTORATION OR MITIGATION TO ENTIRE AREA, NOT JUST AREA SHOWN ON THIS SHEET.
4. WHEN STREAM AND WETLAND BUFFERS OVERLAP THEY WILL BE SHOWN AS WETLAND BUFFERS.

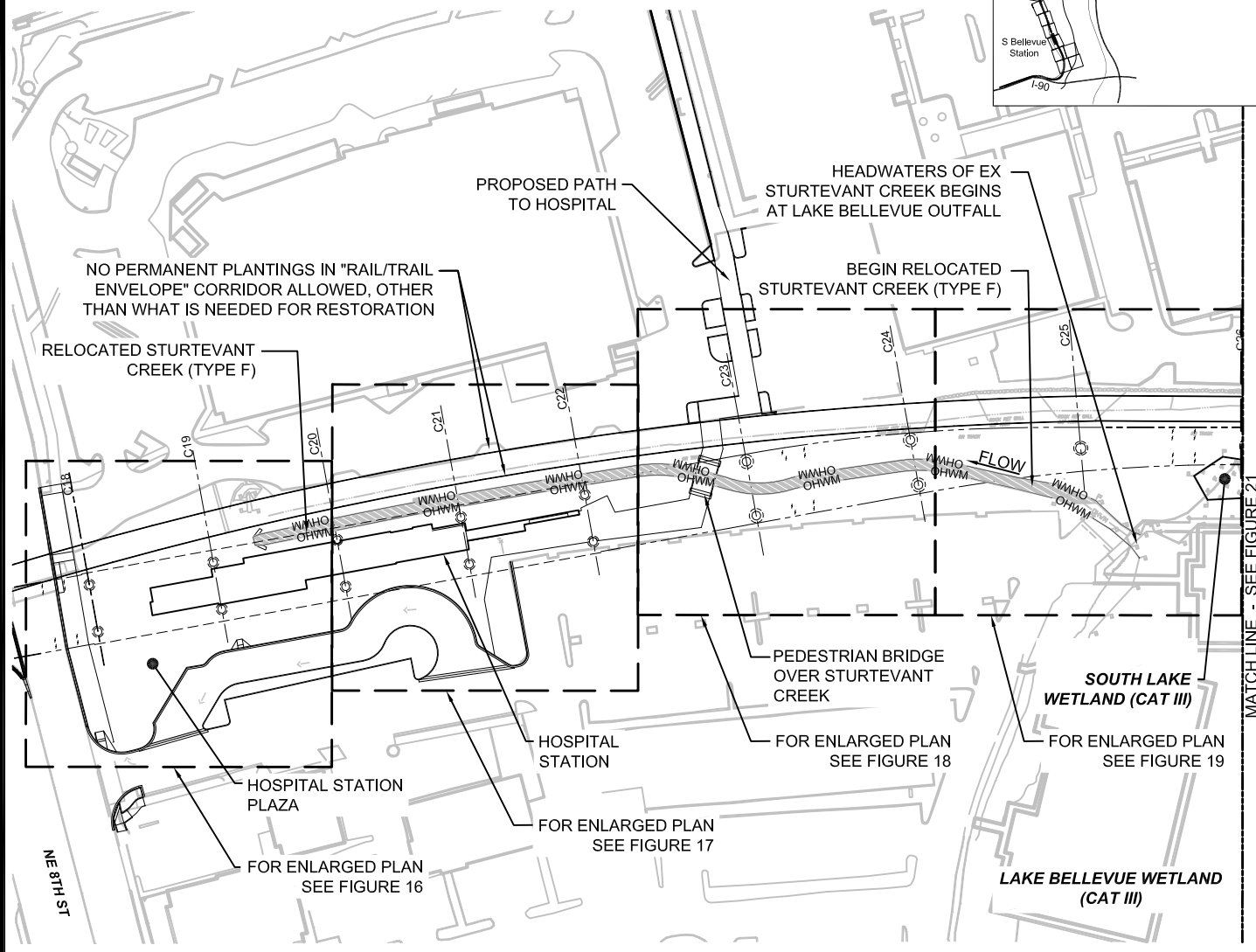
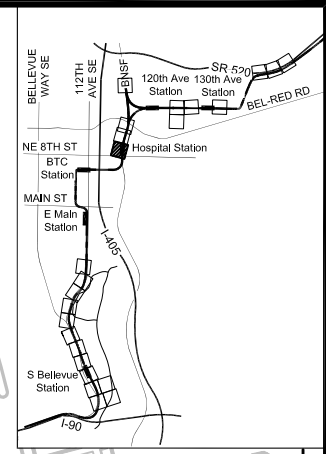

MATCH LINE - SEE FIGURE 21



N.T.S.

05/06/15 | 9:21 AM | JLOGAN J:\55229\CADD\55001\DRAWINGS\ARCH\CRITICAL AREAS REPORT\MITIGATION\8.5X11\11E335-L86-CAR201.DWG



FINAL DESIGN PARTNERS.



SOUND TRANSIT



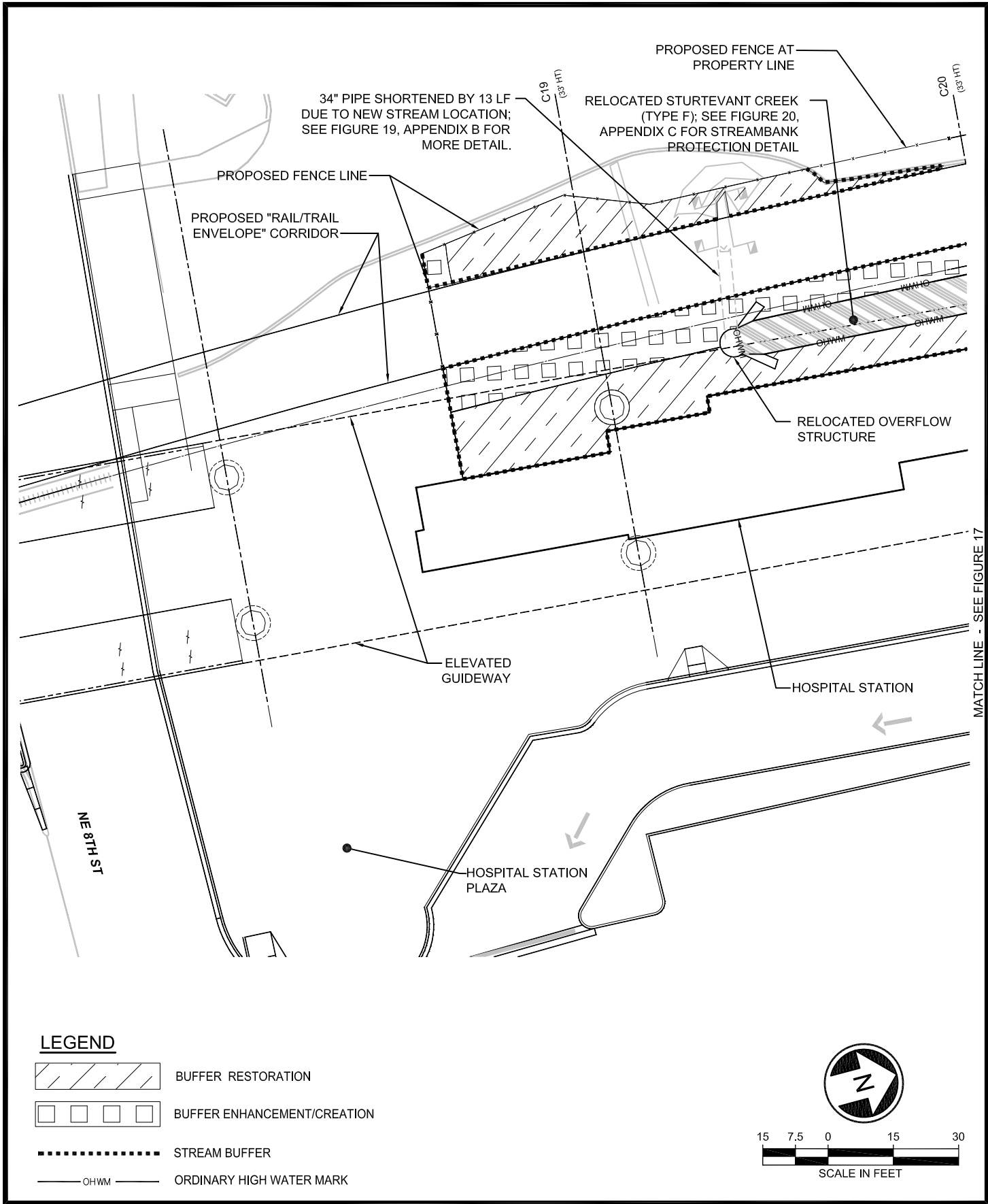

EAST LINK EXTENSION
SOUTH BELLEVUE TO OVERLAKE TRANSIT CENTER
 APPENDIX C
 FIGURE 15
 WETLAND, STREAM, AND BUFFER MITIGATION PLANS

05/06/15 | 8:26 AM | JLOGAN
 J:\55229\CADD\DS001\DRAWINGS\ARCH\CRITICAL AREAS REPORT\MITIGATION\6.SX11\ENLARGEMENTS-CARC.DWG



MATCH LINE - SEE FIGURE 17

LEGEND

-  BUFFER RESTORATION
-  BUFFER ENHANCEMENT/CREATION
-  STREAM BUFFER
-  ORDINARY HIGH WATER MARK



EAST LINK EXTENSION
SOUTH BELLEVUE TO OVERLAKE TRANSIT CENTER
 APPENDIX C
 FIGURE 16
 WETLAND, STREAM, AND BUFFER MITIGATION PLANS



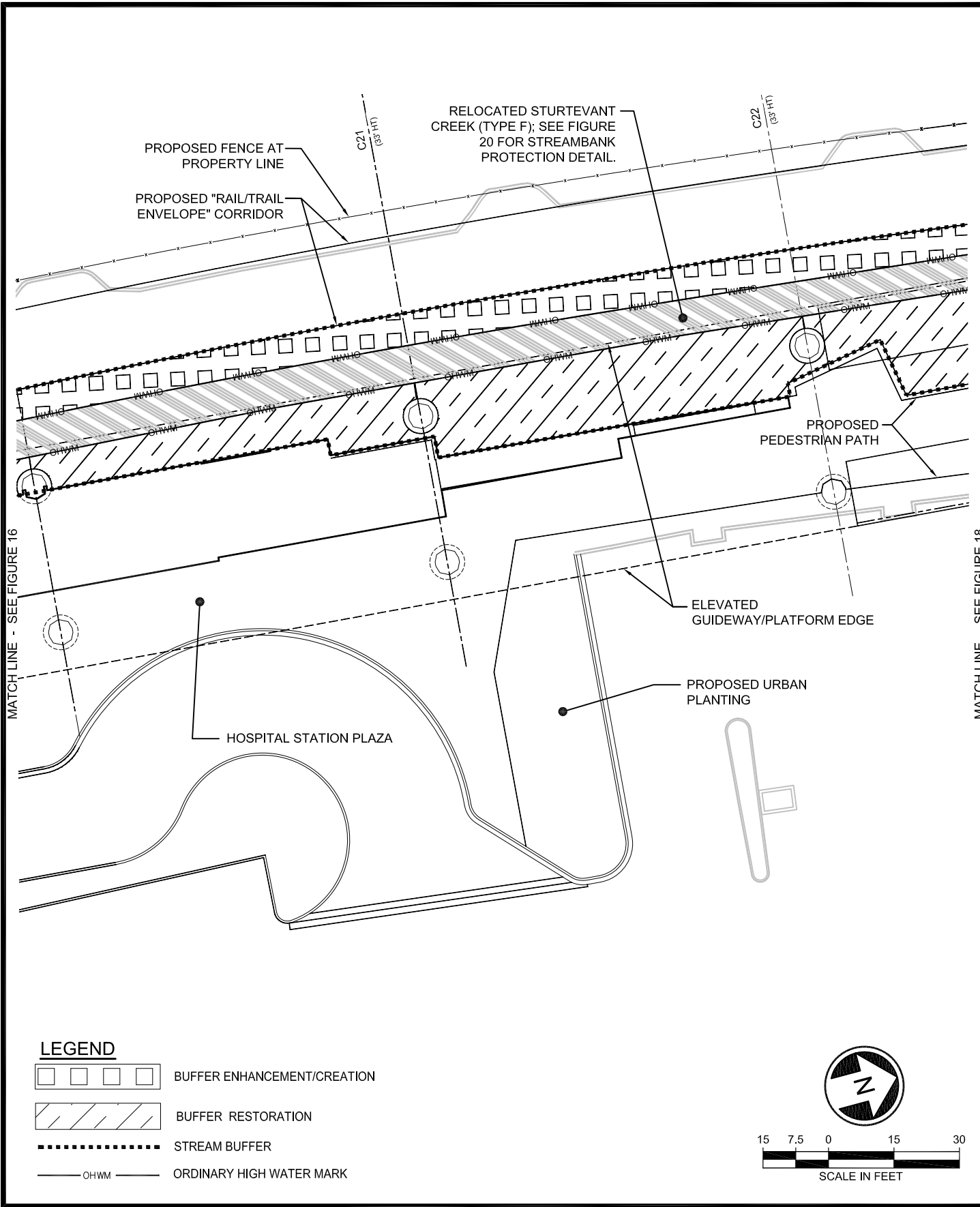

05/06/15 | 8:26 AM | JLOGAN
 J:\15229\CADD\05001\DRAWINGS\ARCH\CRITICAL AREAS REPORT\MITIGATION\6.5X11\ENLARGEMENTS-CARC.DWG

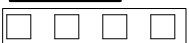

MATCH LINE - SEE FIGURE 16

MATCH LINE - SEE FIGURE 18

LEGEND

-  BUFFER ENHANCEMENT/CREATION
-  BUFFER RESTORATION
-  STREAM BUFFER
-  ORDINARY HIGH WATER MARK



EAST LINK EXTENSION
SOUTH BELLEVUE TO OVERLAKE TRANSIT CENTER
 APPENDIX C
 FIGURE 17
 WETLAND, STREAM, AND BUFFER MITIGATION PLANS

05/06/15 | 8:26 AM | JLOGAN
 J:\15229\CADD\05001\DRAWINGS\ARCH\CRITICAL AREAS REPORT\MITIGATION\6.5X11\ENLARGEMENTS-CARC.DWG

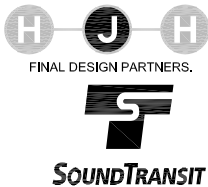
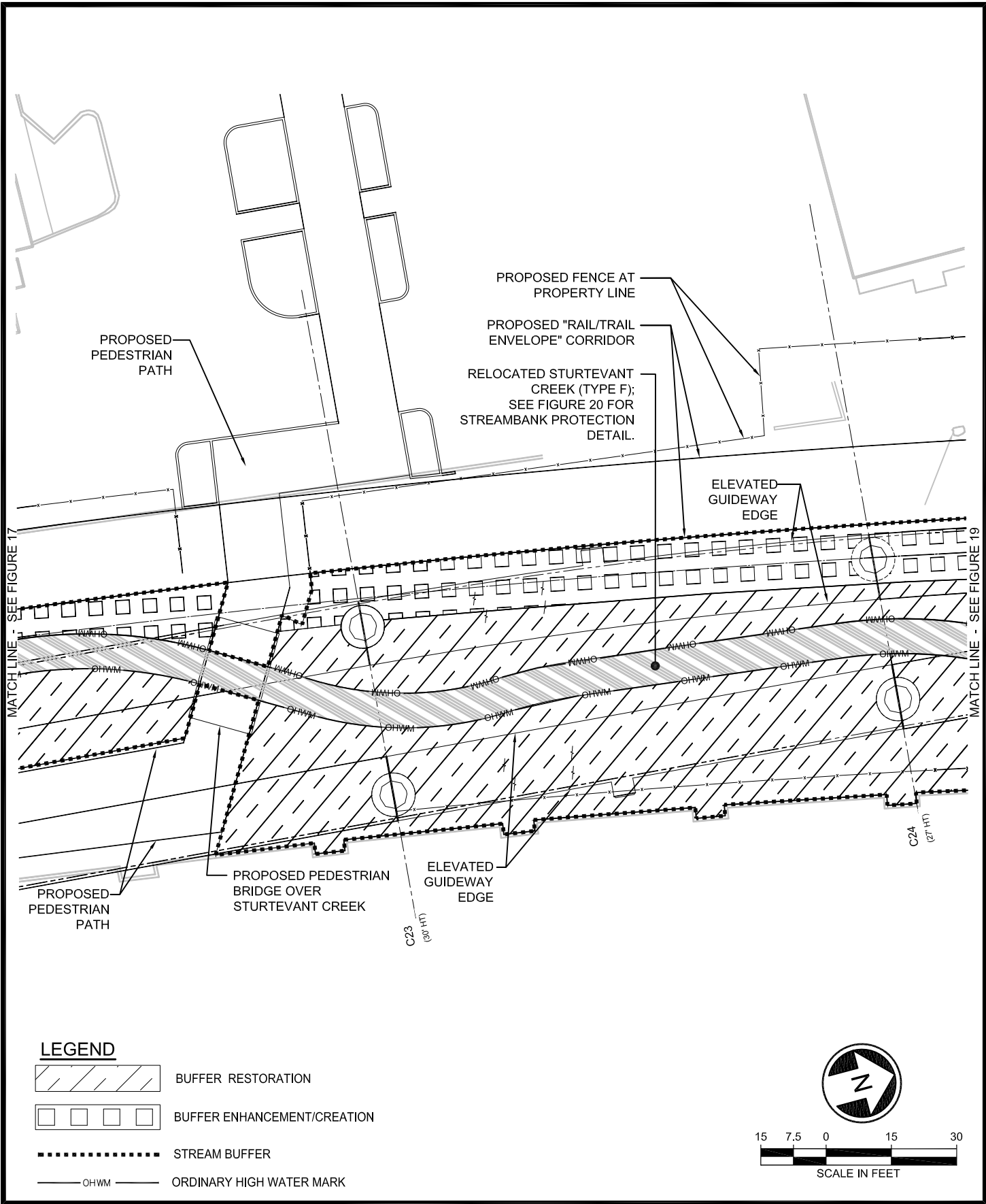



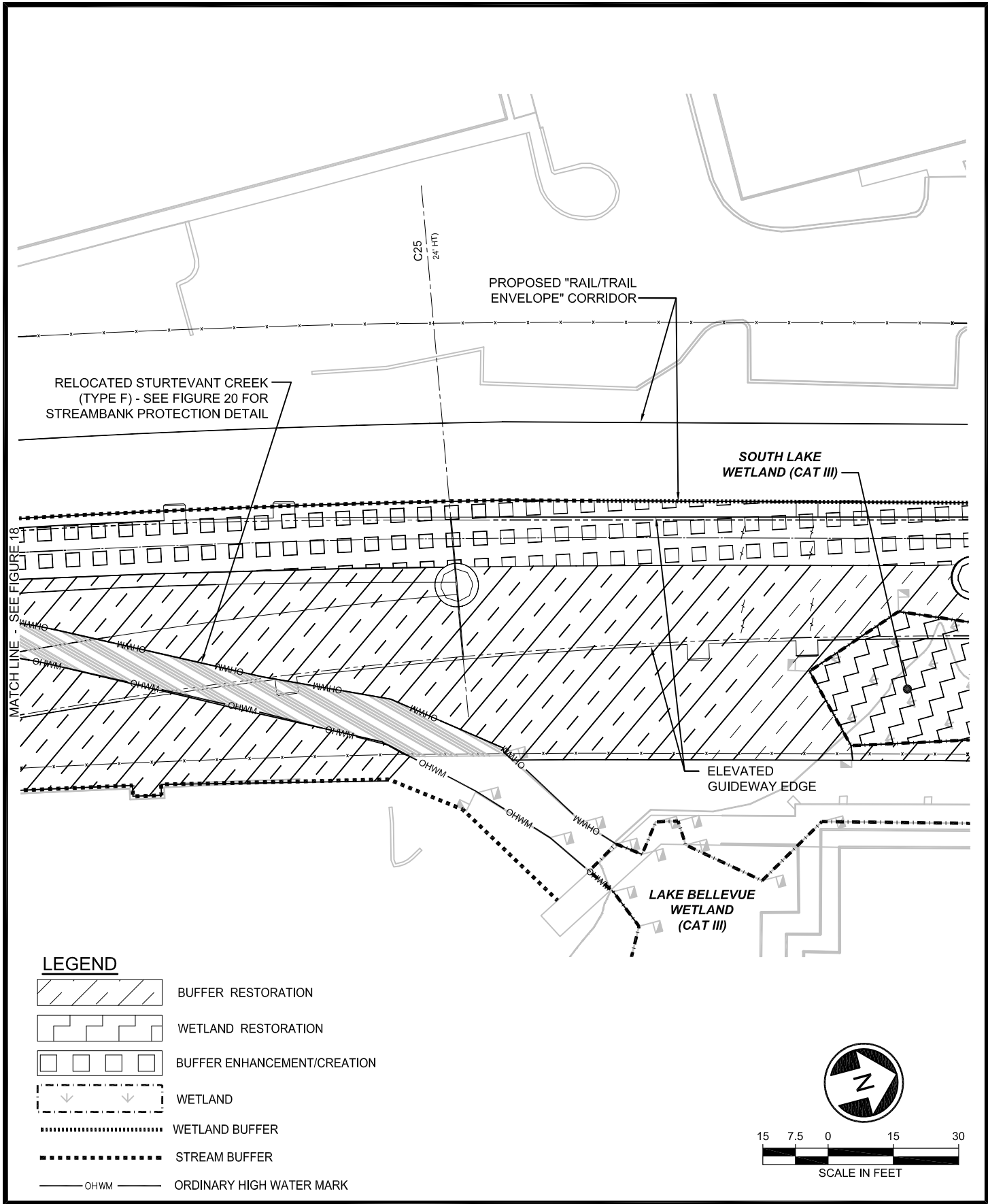

EAST LINK EXTENSION
SOUTH BELLEVUE TO OVERLAKE TRANSIT CENTER
 APPENDIX C
 FIGURE 18
 WETLAND, STREAM, AND BUFFER MITIGATION PLANS

05/06/15 | 8:27 AM | JLOGAN
 J:\5229\CADD\05001\DRAWINGS\ARCH\CRITICAL AREAS REPORT\MITIGATION\6.5X11\ENLARGEMENTS-CARC.DWG

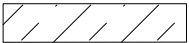
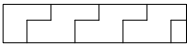
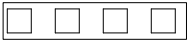

LEGEND

-  BUFFER RESTORATION
-  WETLAND RESTORATION
-  BUFFER ENHANCEMENT/CREATION
-  WETLAND
-  WETLAND BUFFER
-  STREAM BUFFER
-  ORDINARY HIGH WATER MARK

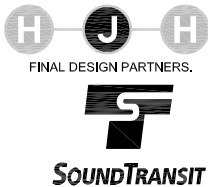
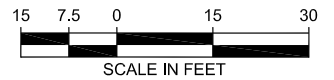

EAST LINK EXTENSION
SOUTH BELLEVUE TO OVERLAKE TRANSIT CENTER
 APPENDIX C
 FIGURE 19
 WETLAND, STREAM, AND BUFFER MITIGATION PLANS

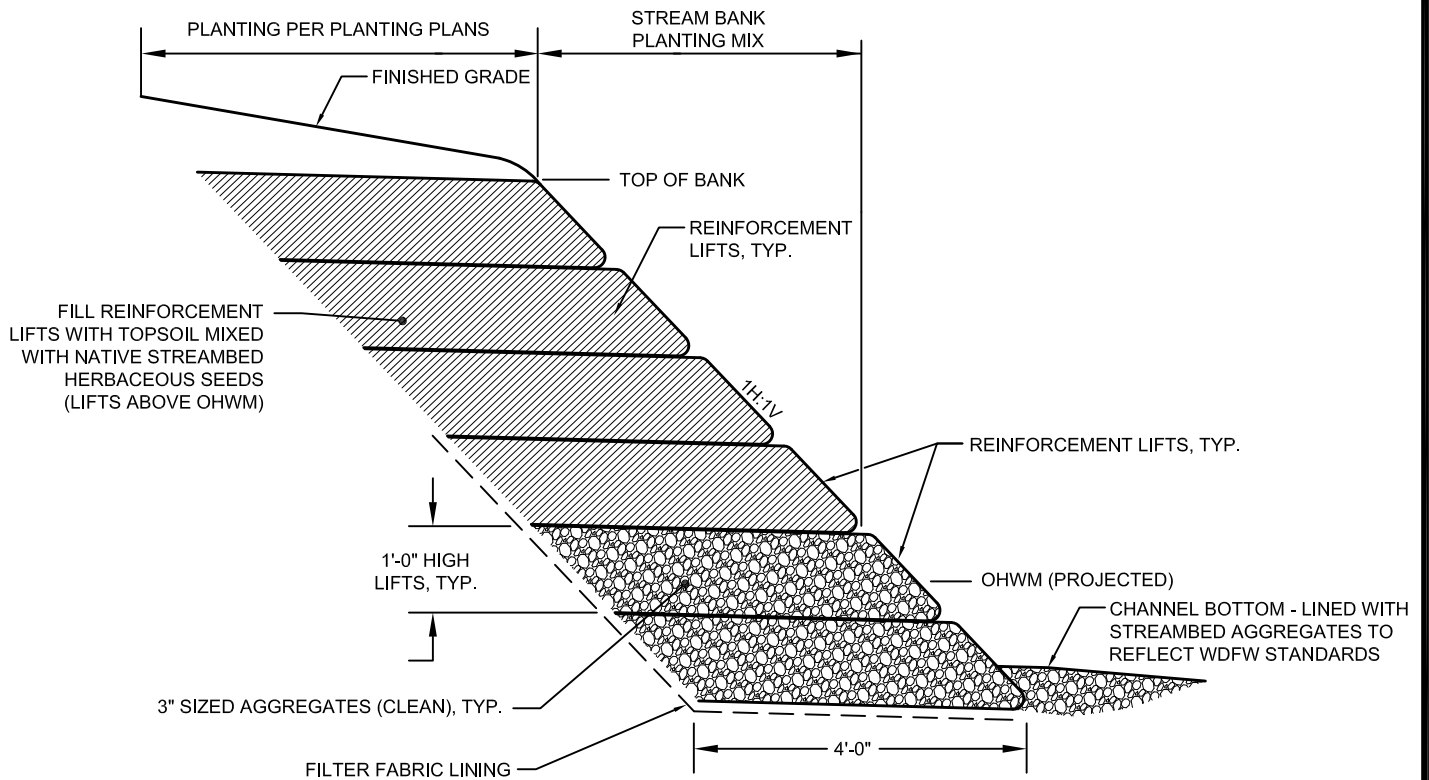

NOTE: STREAMBANK DESIGN APPLIES TO LEFT AND RIGHT BANK

STURTEVANT CREEK BANK STABILIZATION - TYPICAL SECTION

N.T.S.

05/06/15 | 8:32 AM | JLOGAN
J:\55229\CADD\5001\DRAWINGS\ARCH\CRITICAL AREAS REPORT\MITIGATION\8.5X11\11E335-L86-CARC-20.DWG

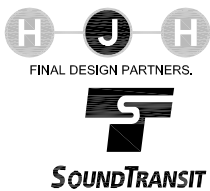



NAME	RESTORATION	ENHANCEMENT	CREATION
SOUTH LAKE WETLAND	0.09 ACRE	NA	NA
SOUTH LAKE WETLAND BUFFER	0.25 ACRE	NA	0.10 ACRE
CENTRAL LAKE WETLAND	0.03 ACRE	NA	NA
CENTRAL LAKE WETLAND BUFFER	0.12 ACRE	NA	NA
NORTH LAKE WETLAND	0.04 ACRE	NA	NA

NOTES:

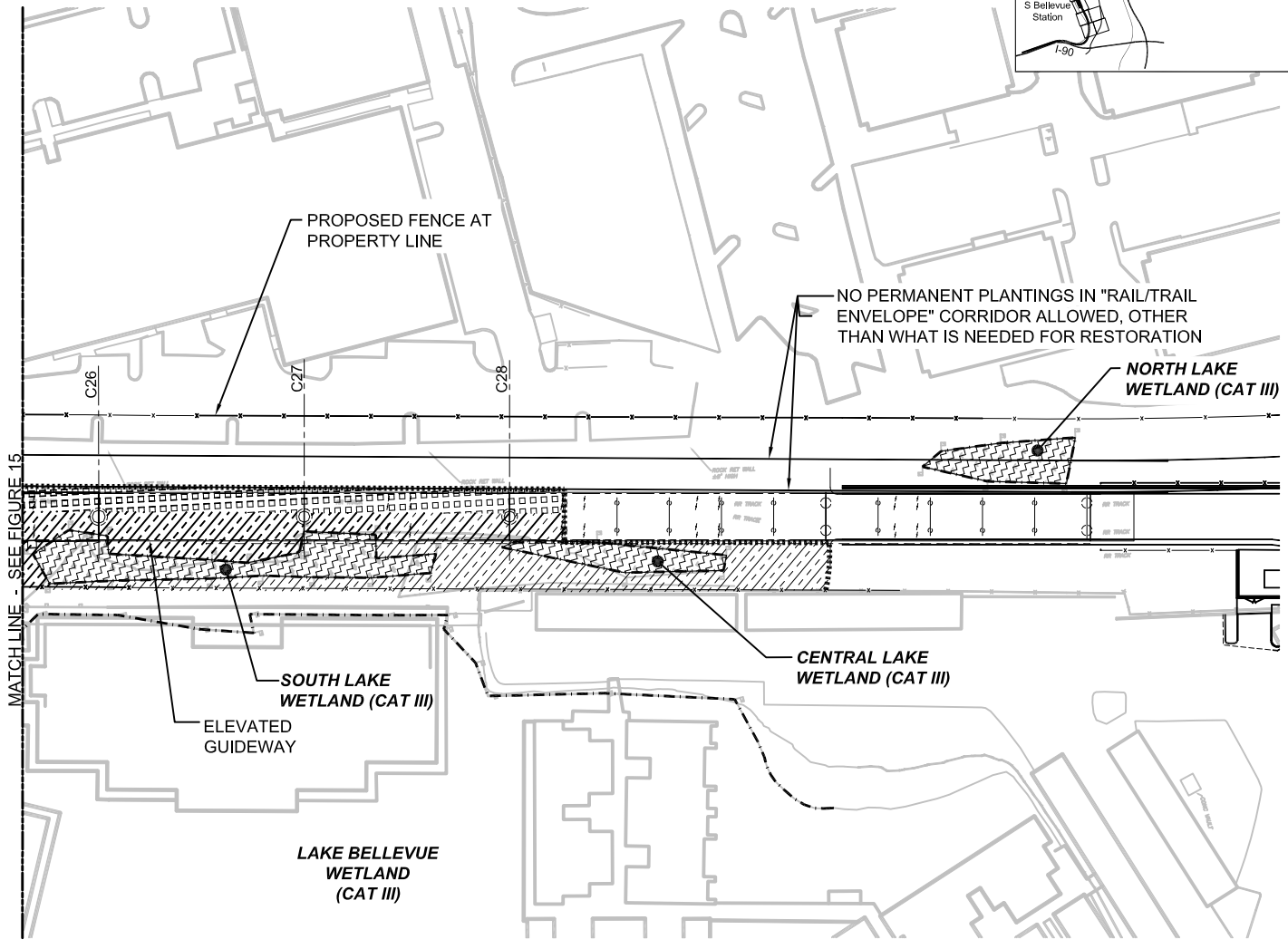
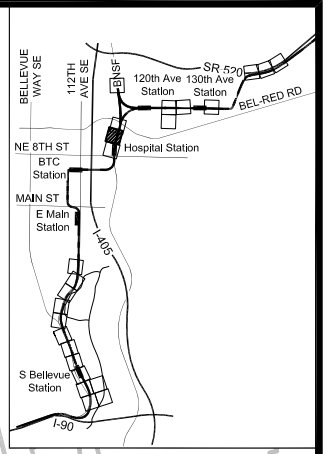
1. REFER TO FIGURES 1 TO 12 IN APPENDIX D FOR PLANTING PLANS.
2. VALUES REPRESENT RESTORATION OR MITIGATION TO ENTIRE AREA, NOT JUST AREA SHOWN ON THIS SHEET.
3. WHEN STREAM AND WETLAND BUFFERS OVERLAP THEY WILL BE SHOWN AS WETLAND BUFFERS.

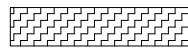
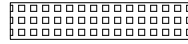
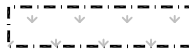

LEGEND

-  BUFFER RESTORATION
-  WETLAND RESTORATION
-  BUFFER ENHANCEMENT/CREATION
-  WETLAND
-  WETLAND BUFFER

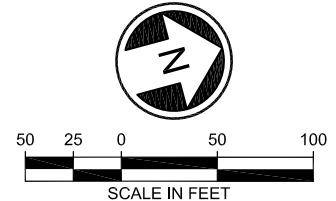

05/06/15 | 9:21 AM | JLOGAN JJ55229\CADD\5001\DRAWINGS\ARCH\CRITICAL AREAS REPORT\MITIGATION\8.5X11E335-186-CAR201.DWG



EAST LINK EXTENSION
SOUTH BELLEVUE TO OVERLAKE TRANSIT CENTER
 APPENDIX C
 FIGURE 21
 WETLAND, STREAM, AND BUFFER MITIGATION PLANS

NAME	RESTORATION	ENHANCEMENT	CREATION
BNSF EAST WETLAND	0.08 ACRE	NA	NA
BNSF EAST WETLAND BUFFER	0.01 ACRE	NA	NA

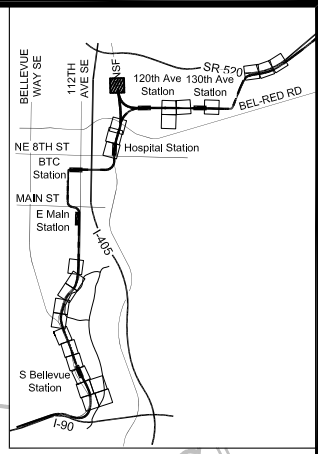



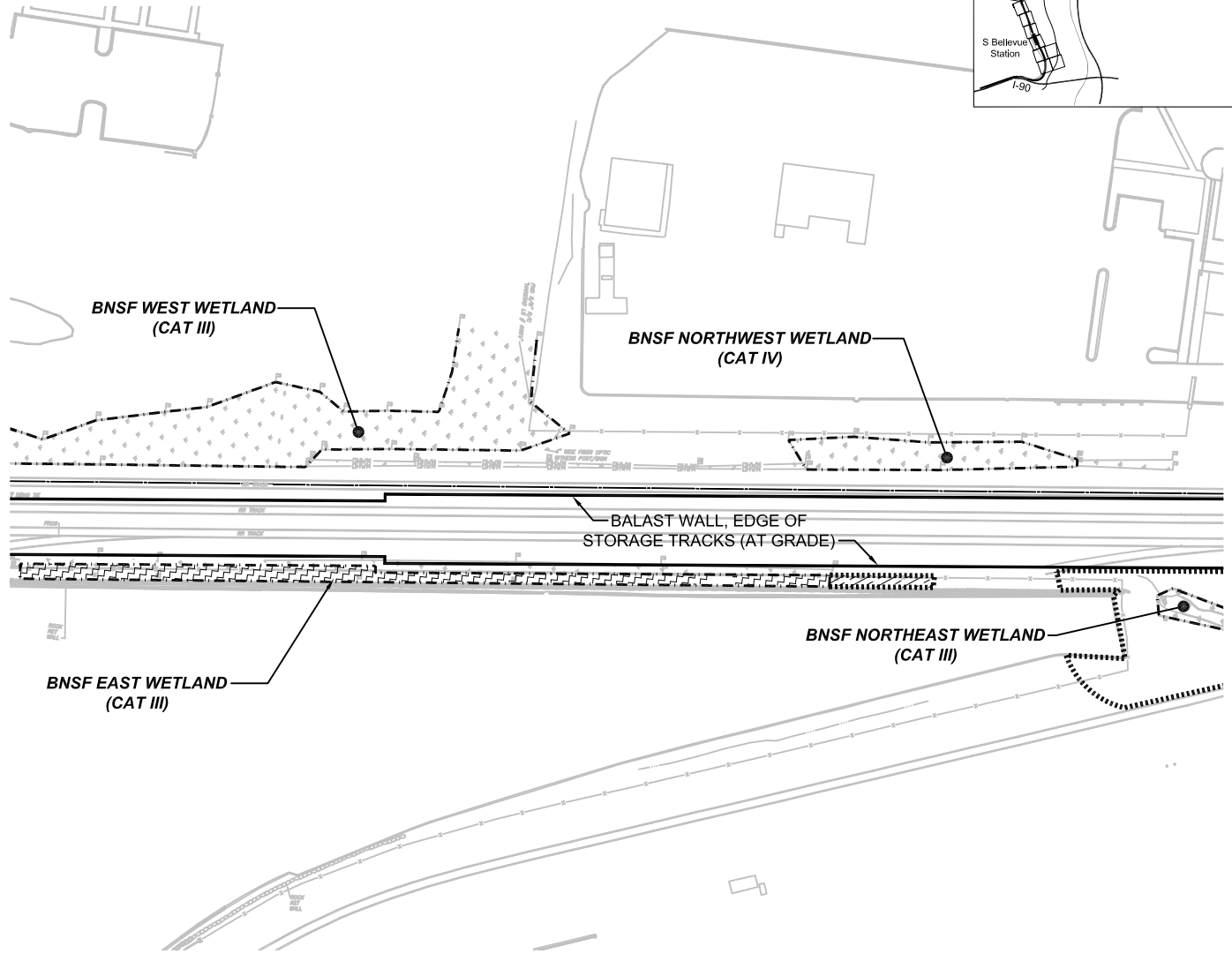

NOTES:

1. REFER TO FIGURES 1 TO 12 IN APPENDIX D FOR PLANTING PLANS.
2. VALUES REPRESENT RESTORATION OR MITIGATION TO ENTIRE AREA, NOT JUST AREA SHOWN ON THIS SHEET.



LEGEND

-  BUFFER RESTORATION
-  WETLAND RESTORATION
-  WETLAND
-  WETLAND BUFFER

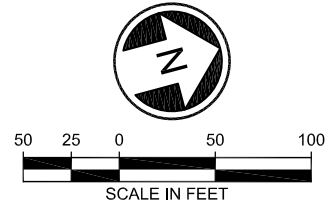

05/06/15 | 9:27 AM | JLOGAN JJ55229\CADD\5001\DRAWINGS\ARCH\CRITICAL AREAS REPORT\MITIGATION\8.5X11\11E340-187-CAR201.DWG

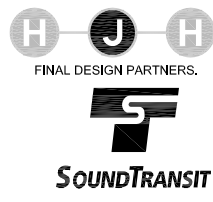

EAST LINK EXTENSION
SOUTH BELLEVUE TO OVERLAKE TRANSIT CENTER
 APPENDIX C
 FIGURE 22
 WETLAND, STREAM, AND BUFFER MITIGATION PLANS

NAME	RESTORATION	ENHANCEMENT	CREATION
KELSEY WEST TRIBUTARY POND WETLAND	0.05 ACRE	NA	NA
KELSEY WEST TRIBUTARY POND WETLAND BUFFER	0.36 ACRE	NA	NA
WEST TRIBUTARY TO KELSEY CREEK	3814 SF ^a	NA	NA
WEST TRIBUTARY TO KELSEY CREEK BUFFER	0.12 ACRE	NA	NA
KELSEY WEST TRIBUTARY STREAM WETLAND	NA	0.04 ACRE	NA
KELSEY WEST TRIBUTARY STREAM WETLAND BUFFER	NA	NA	NA
NEW WETLAND (WEST TRIBUTARY)	NA	NA	0.55 ACRE
NEW WETLAND (WEST TRIBUTARY) BUFFER CREATION / ENHANCEMENT	NA	NA	1.15 ACRE

a. ADDRESSES RESTORATION OF TEMPORARY IMPACTS AND OPEN CHANNEL IMPROVEMENTS.

NOTES:

1. REFER TO FIGURES 1 TO 12 IN APPENDIX D FOR PLANTING PLANS.
2. VALUES REPRESENT RESTORATION OR MITIGATION TO ENTIRE AREA, NOT JUST AREA SHOWN ON THIS SHEET.
3. WHEN STREAM AND WETLAND BUFFERS OVERLAP THEY WILL BE SHOWN AS WETLAND BUFFERS.
4. GUIDEWAY CLEARANCE AT COLUMN NEAR AREAS IS LISTED AS "XX'HT"

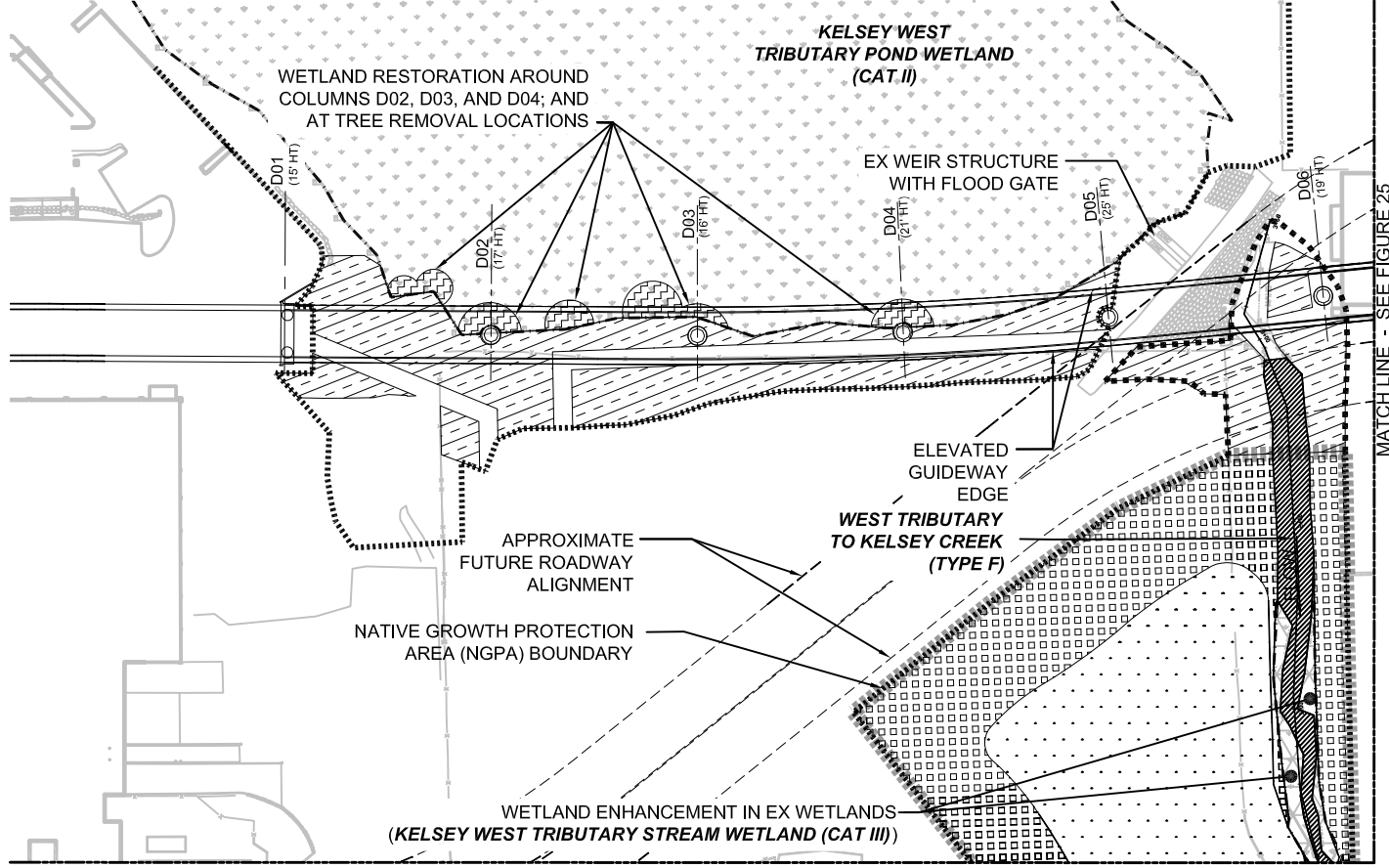
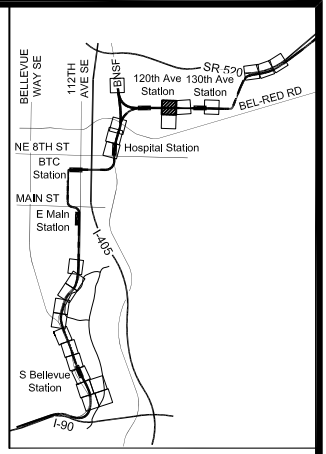

LEGEND

- BUFFER RESTORATION
- WETLAND RESTORATION
- WETLAND ENHANCEMENT
- BUFFER ENHANCEMENT/CREATION
- WETLAND CREATION
- STREAM RESTORATION AND ENHANCEMENT
- WETLAND
- WETLAND BUFFER
- STREAM BUFFER
- OHWM
- ORDINARY HIGH WATER MARK
- NGPA

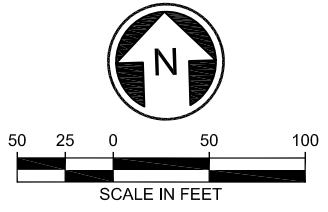

05/06/15 | 9:28 AM | JLOGAN J:\55229\CADD\55001\DRAWINGS\ARCH\CRITICAL AREAS REPORT\MITIGATION\8.5X11E340-L87-CAR201.DWG

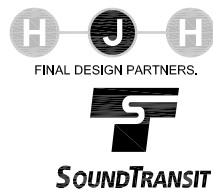

EAST LINK EXTENSION
SOUTH BELLEVUE TO OVERLAKE TRANSIT CENTER
 APPENDIX C
 FIGURE 23
 WETLAND, STREAM, AND BUFFER MITIGATION PLANS

NAME	RESTORATION	ENHANCEMENT	CREATION
NEW WETLAND (WEST TRIBUTARY)	NA	NA	0.55 ACRE
NEW WETLAND (WEST TRIBUTARY) BUFFER CREATION / ENHANCEMENT	NA	NA	1.15 ACRE

NOTES:

- REFER TO FIGURES 1 TO 12 IN APPENDIX D FOR PLANTING PLANS.
- VALUES REPRESENT RESTORATION OR MITIGATION TO ENTIRE AREA, NOT JUST AREA SHOWN ON THIS SHEET.
- WHEN STREAM AND WETLAND BUFFERS OVERLAP THEY WILL BE SHOWN AS WETLAND BUFFERS

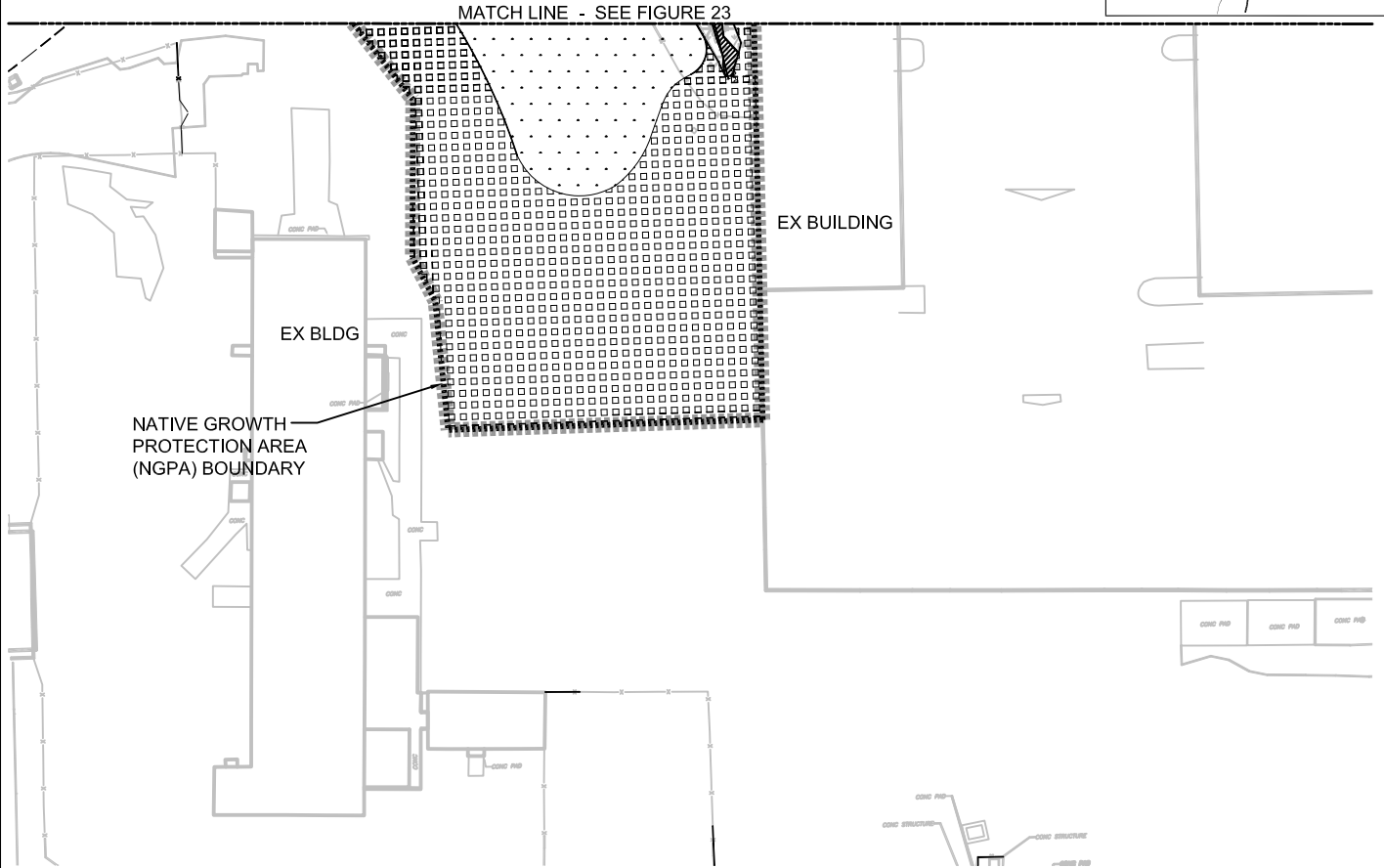
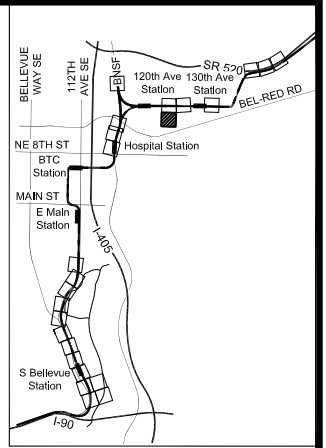

LEGEND

- WETLAND ENHANCEMENT
- BUFFER ENHANCEMENT/CREATION
- WETLAND CREATION
- STREAM RESTORATION AND ENHANCEMENT
- WETLAND
- WETLAND BUFFER
- OHWM ORDINARY HIGH WATER MARK
- NGPA

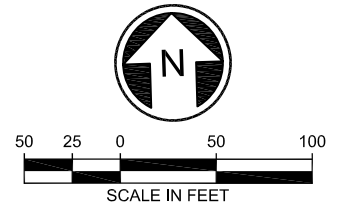

05/06/15 | 9:29 AM | JLOGAN J:\52229\CADD\5001\DRAWINGS\ARCH\CRITICAL AREAS REPORT\MITIGATION\8.5X11E340-L87-CAR201.DWG



**EAST LINK EXTENSION
SOUTH BELLEVUE TO OTC
APPENDIX C
FIGURE 24
WETLAND, STREAM, AND BUFFER MITIGATION PLANS**

NAME	RESTORATION	ENHANCEMENT
STREAM C	1,560 SF ^a	NA
STREAM C BUFFER	0.10 ACRE	NA



a. ADDRESSES RESTORATION OF TEMPORARY IMPACTS.

NOTES:

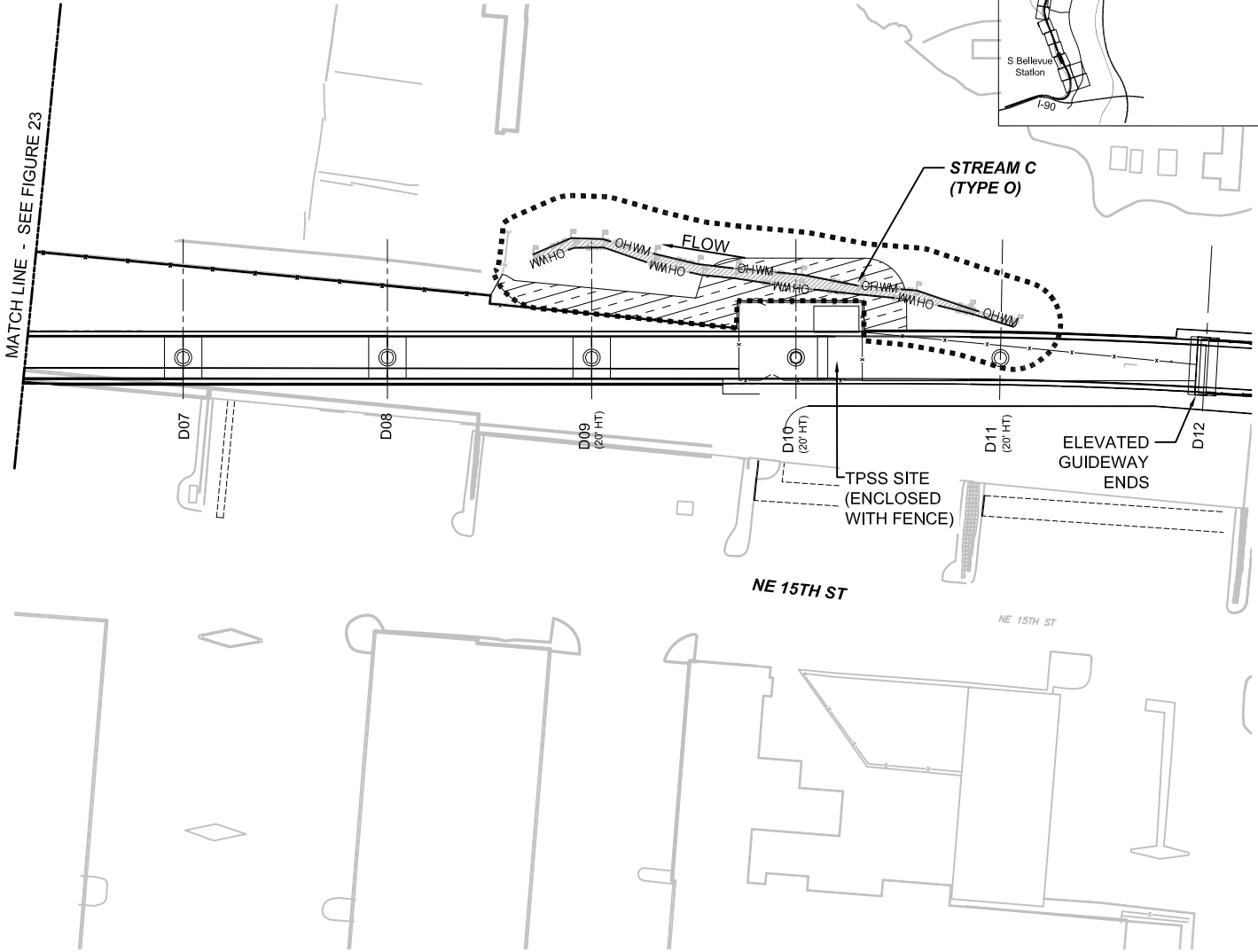
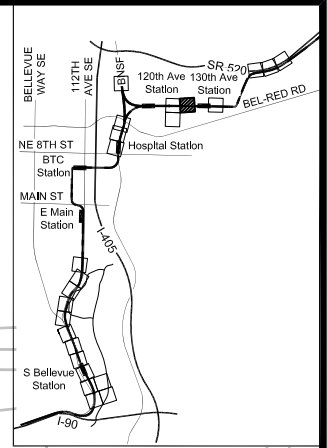
1. REFER TO FIGURES 1 TO 12 IN APPENDIX D FOR PLANTING PLANS.
2. VALUES REPRESENT RESTORATION OR MITIGATION TO ENTIRE AREA, NOT JUST AREA SHOWN ON THIS SHEET.
3. GUIDEWAY CLEARANCE AT COLUMN NEAR AREAS IS LISTED AS "XX'HT"

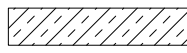
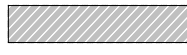

LEGEND

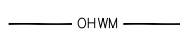
-  BUFFER RESTORATION
-  STREAM RESTORATION (FROM TEMPORARY IMPACTS)
-  STREAM BUFFER
-  ORDINARY HIGH WATER MARK

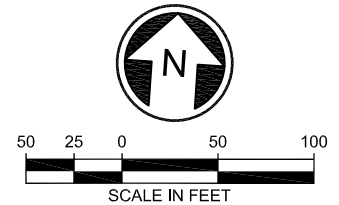

05/06/15 | 9:30 AM | JLOGAN J:\55229\CADD\55001\DRAWINGS\ARCH\CRITICAL AREAS REPORT\MITIGATION\8.5X11E340-L87-CAR201.DWG

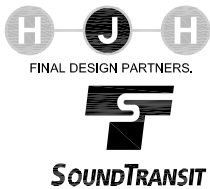

**EAST LINK EXTENSION
SOUTH BELLEVUE TO OVERLAKE TRANSIT CENTER
APPENDIX C
FIGURE 25
WETLAND, STREAM, AND BUFFER MITIGATION PLANS**



NAME	RESTORATION	ENHANCEMENT
SR 520 WEST WETLAND	0.23 ACRE	NA
SR 520 WEST WETLAND BUFFER	0.55 ACRE	NA

NOTES:

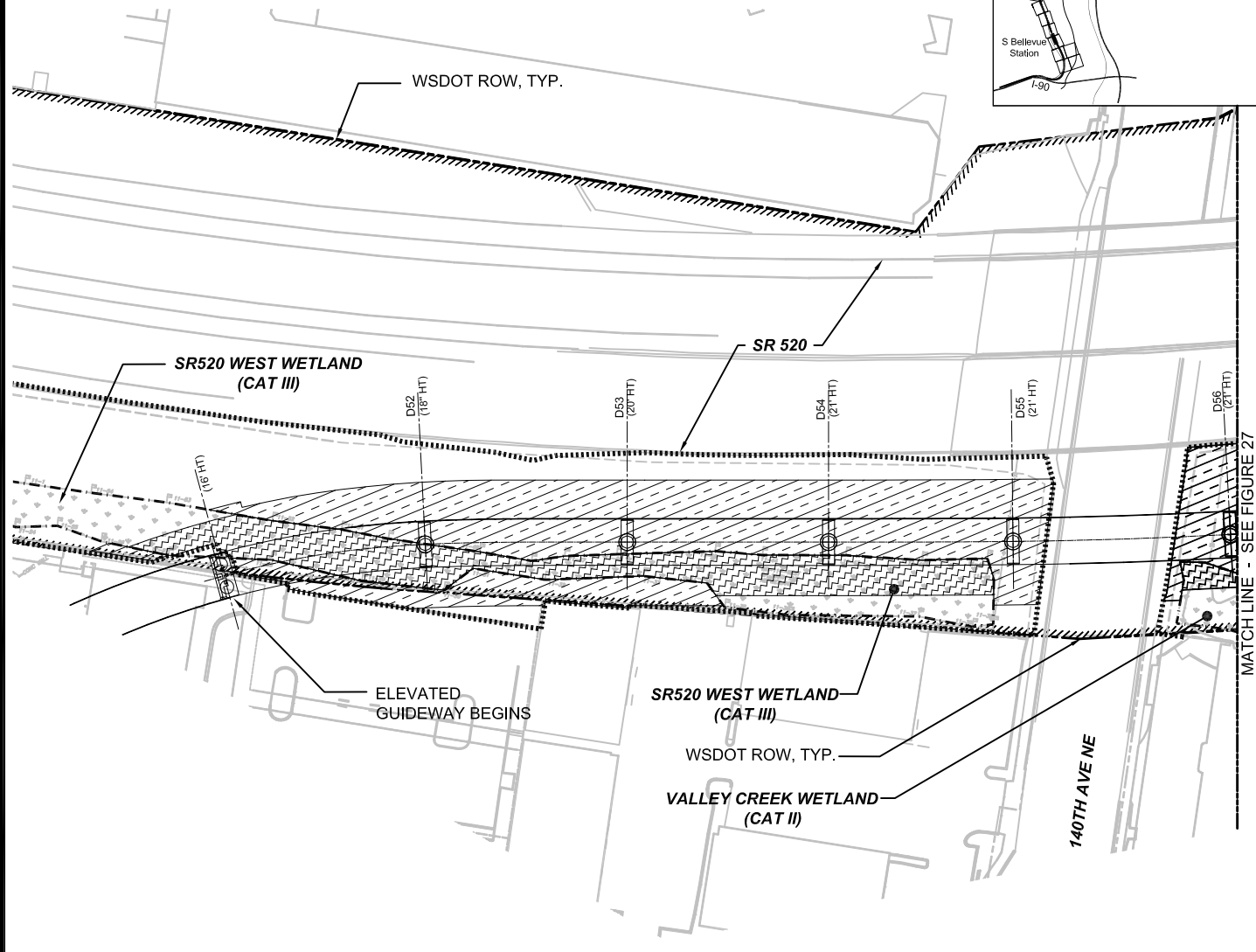
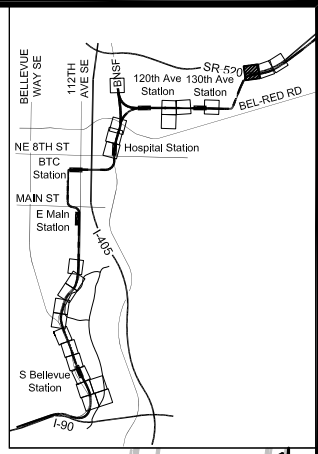
1. REFER TO FIGURES 1 TO 12 IN APPENDIX D FOR PLANTING PLANS.
2. VALUES REPRESENT RESTORATION OR MITIGATION TO ENTIRE AREA, NOT JUST AREA SHOWN ON THIS SHEET.
3. GUIDEWAY CLEARANCE AT COLUMNS NEAR CRITICAL AREAS IS LISTED AS "XX'HT"

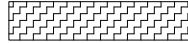

LEGEND

-  BUFFER RESTORATION
-  WETLAND RESTORATION
-  WETLAND
-  WETLAND BUFFER

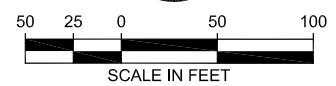

05/06/15 | 9:32 AM | JLOGAN JJ55229\CADD\5001\DRAWINGS\ARCH\CRITICAL AREAS REPORT\MITIGATION\8.5X11\E360-L88-CAR201.DWG

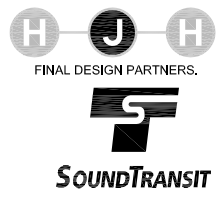

EAST LINK EXTENSION
SOUTH BELLEVUE TO OVERLAKE TRANSIT CENTER
 APPENDIX C
 FIGURE 26
 WETLAND, STREAM, AND BUFFER MITIGATION PLANS

NAME	RESTORATION	ENHANCEMENT
VALLEY CREEK WETLAND	0.01 ACRE	NA
VALLEY CREEK WETLAND BUFFER	0.27 ACRE	NA

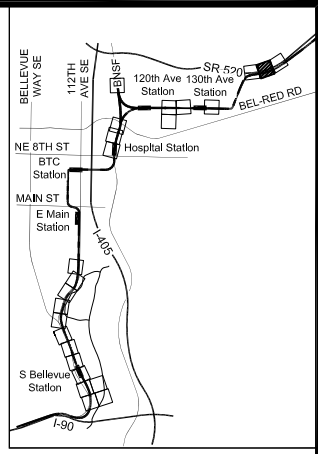

- NOTES:**
- REFER TO FIGURES 1 TO 12 IN APPENDIX D FOR PLANTING PLANS.
 - VALUES REPRESENT RESTORATION OR MITIGATION TO ENTIRE AREA, NOT JUST AREA SHOWN ON THIS SHEET.
 - WHEN STREAM AND WETLAND BUFFERS OVERLAP THEY WILL BE SHOWN AS WETLAND BUFFERS.
 - GUIDEWAY CLEARANCE AT COLUMNS NEAR CRITICAL AREAS IS LISTED AS "XX'HT"

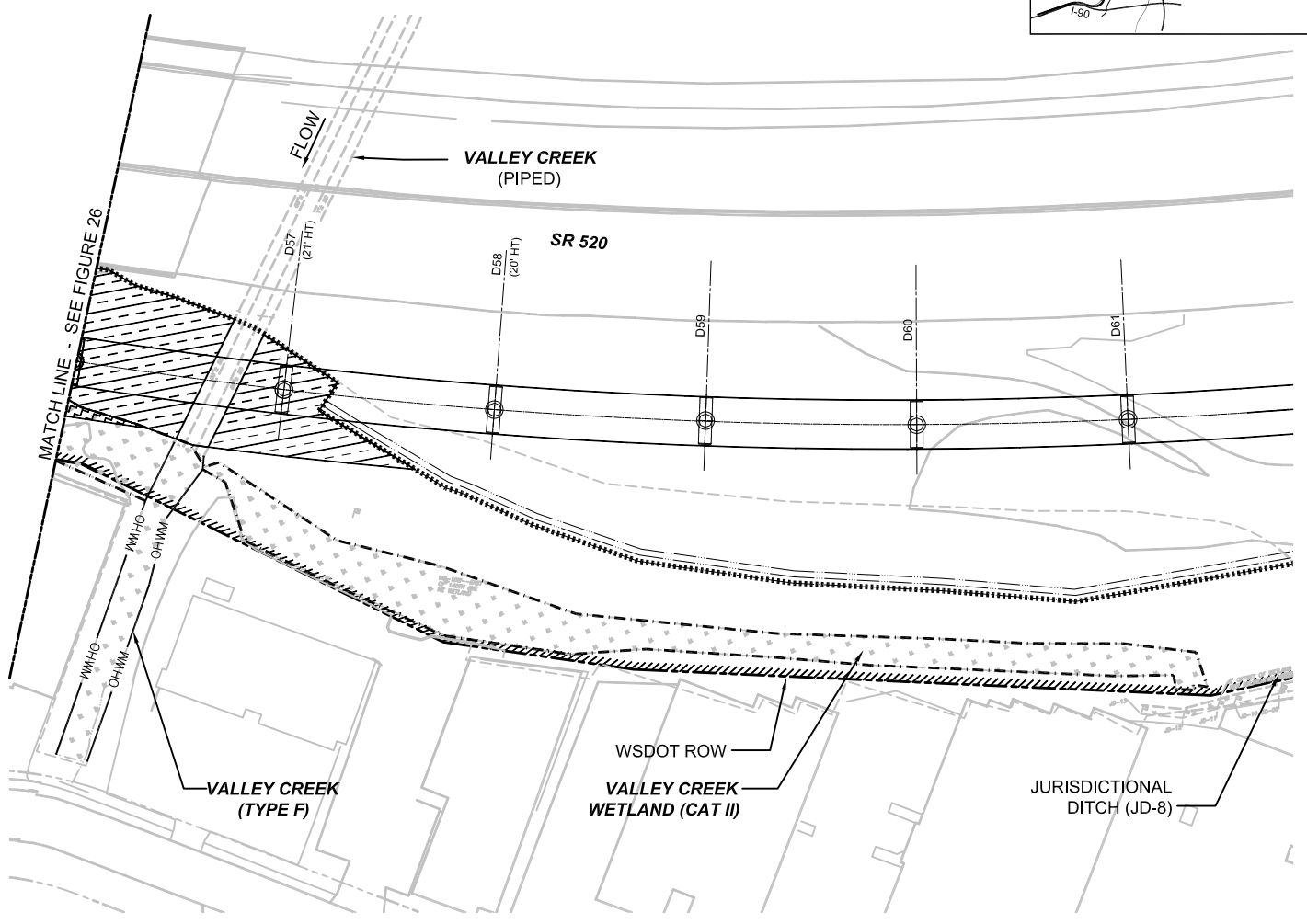

LEGEND

	BUFFER RESTORATION		WETLAND BUFFER
	WETLAND RESTORATION		STREAM BUFFER
	WETLAND		OHWM ORDINARY HIGH WATER MARK

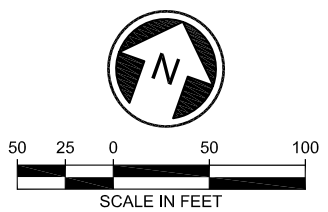

05/06/15 | 9:32 AM | JLOGAN J:\55229\CADD\55001\DRAWINGS\ARCH\CRITICAL AREAS REPORT\MITIGATION\8.5X11\E360-L88-CAR201.DWG



EAST LINK EXTENSION
SOUTH BELLEVUE TO OVERLAKE TRANSIT CENTER
 APPENDIX C
 FIGURE 27
 WETLAND, STREAM, AND BUFFER MITIGATION PLANS

NAME	TEMPORARY IMPACTS	MITIGATION
COAL CREEK	10,736 SF	10,736 SF (RESTORATION)
WETLAND D	0.10 ACRE	0.10 ACRE (RESTORATION)

NOTES:

1. IMPACT VALUES REPRESENT IMPACTS TO ENTIRE PROJECT AREA (WORK ZONES 1 AND 2).
2. SOME MINOR TEMPORARY STREAM AND WETLAND BUFFER IMPACTS WILL OCCUR AS A RESULT OF CONSTRUCTION ACTIVITIES. ALL TEMPORARY BUFFER IMPACTS WILL BE RESTORED WITHIN 12 MONTHS AND WILL BE RESTORED IN-KIND.

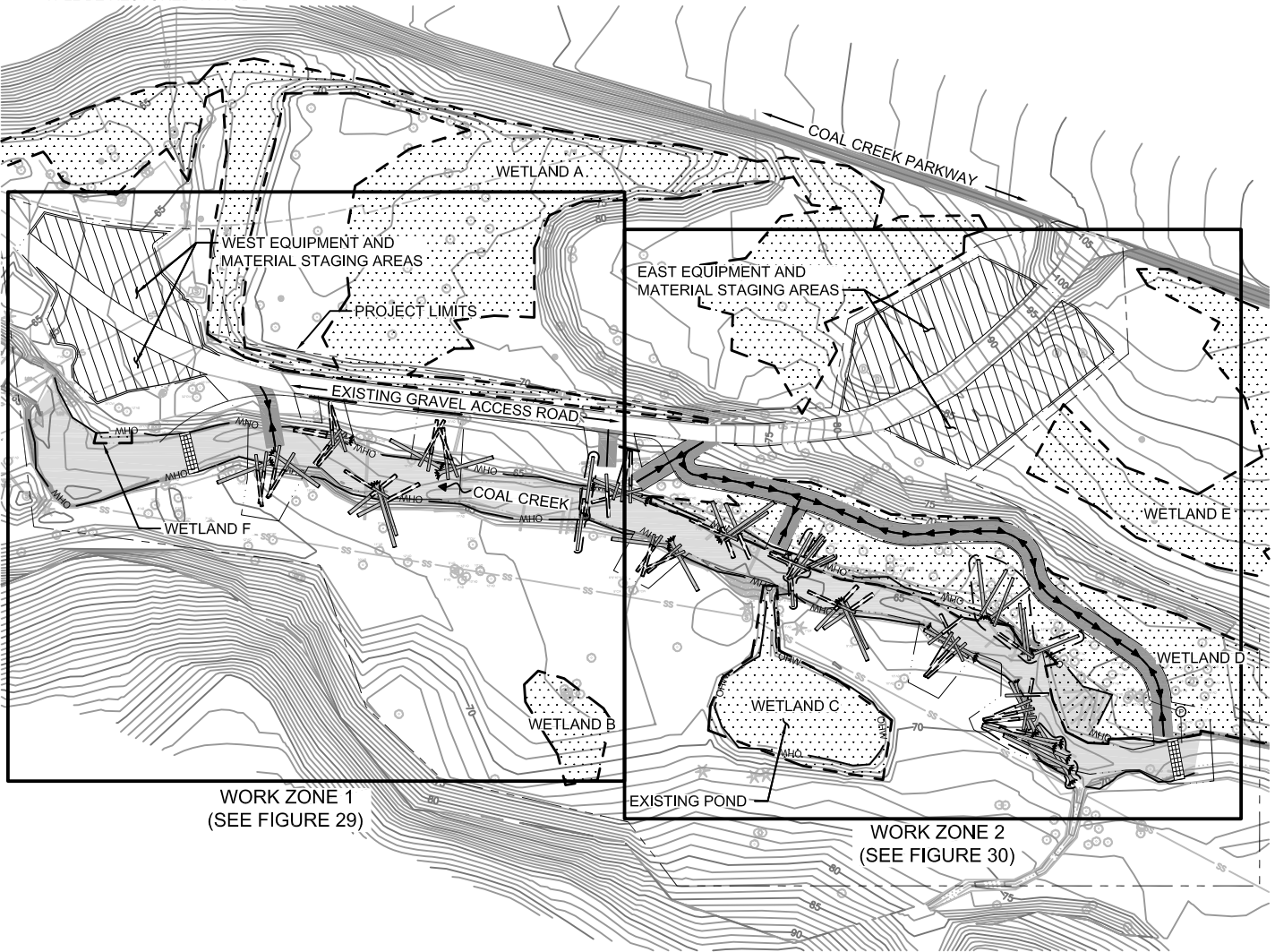

EXISTING LEGEND:

- MINOR CONTOUR (1 FOOT)
- 75 — MAJOR CONTOUR (5 FOOT)
- OHW — ORDINARY HIGH WATER
- — — — — PROPERTY LINE
- SS — SS — SANITARY SEWER PIPE
- OHW — MHO — OHW — ACTIVE COAL CREEK STREAM CHANNEL
- — — — — WETLANDS
- ★ CONIFER TREE
- DECIDUOUS TREE
- SANITARY SEWER MANHOLE

PROPOSED LEGEND:

- — — — — PROJECT LIMITS
- · · · · · CLEARING LIMITS
- ▨ EQUIPMENT AND MATERIAL STAGING AREA
- → → → → TEMPORARY CONSTRUCTION ACCESS
- ▣ TEMPORARY COFFER DAM
- BURIED PORTION OF LOG (PLAN VIEW ONLY)
- EXPOSED PORTION OF LOG

- ✂ TYPE 1 ELS
- ✂ TYPE 2 ELS
- ✂ TYPE 3 ELS
- ✂ TYPE 4 ELS

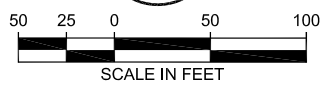

05/20/15 | 8:26 AM | TPRESKOTT
C:\PROJ\2010\10-04788-040\CADD\DWG\CAR\FIG 28.DWG



EAST LINK EXTENSION
SOUTH BELLEVUE TO OVERLAKE TRANSIT CENTER
 APPENDIX C
 FIGURE 28
 WETLAND, STREAM, AND BUFFER MITIGATION PLANS

NAME	TEMPORARY IMPACTS	MITIGATION
COAL CREEK	10,736 SF	10,736 SF (RESTORATION)
WETLAND D	0.10 ACRE	0.10 ACRE (RESTORATION)

NOTES:

1. IMPACT VALUES REPRESENT IMPACTS TO ENTIRE PROJECT AREA (WORK ZONES 1 AND 2).
2. SOME MINOR TEMPORARY STREAM AND WETLAND BUFFER IMPACTS WILL OCCUR AS A RESULT OF CONSTRUCTION ACTIVITIES. ALL TEMPORARY BUFFER IMPACTS WILL BE RESTORED WITHIN 12 MONTHS AND WILL BE RESTORED IN-KIND.

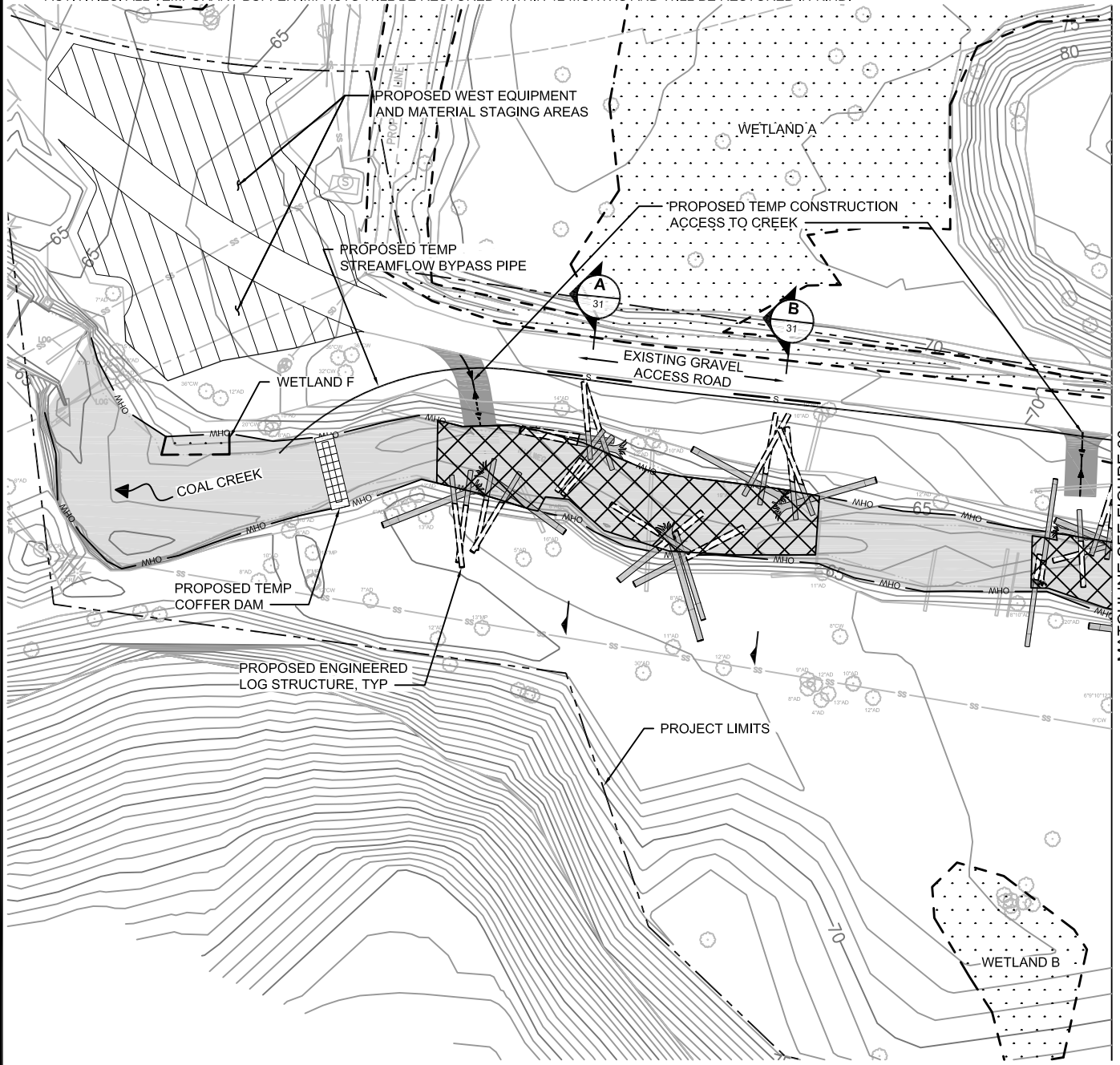

MATCHLINE SEE FIGURE 30

LEGEND:

 TEMPORARY STREAM IMPACT FOR MITIGATION CONSTRUCTION

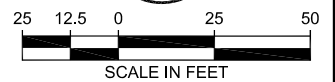

05/20/15 | 8:34 AM | TPRESKOTT
C:\PROJ\2010\10-04\788-040\CADD\DWG\CAR\FIG 29.DWG



EAST LINK EXTENSION
SOUTH BELLEVUE TO OVERLAKE TRANSIT CENTER
 APPENDIX C
 FIGURE 29
 WETLAND, STREAM, AND BUFFER MITIGATION PLANS

NAME	TEMPORARY IMPACTS	MITIGATION
COAL CREEK	10,736 SF	10,736 SF (RESTORATION)
WETLAND D	0.10 ACRE	0.10 ACRE (RESTORATION)

NOTES:

1. IMPACT VALUES REPRESENT IMPACTS TO ENTIRE PROJECT AREA (WORK ZONES 1 AND 2).
2. SOME MINOR TEMPORARY STREAM AND WETLAND BUFFER IMPACTS WILL OCCUR AS A RESULT OF CONSTRUCTION ACTIVITIES. ALL TEMPORARY BUFFER IMPACTS WILL BE RESTORED WITHIN 12 MONTHS AND WILL BE RESTORED IN-KIND.

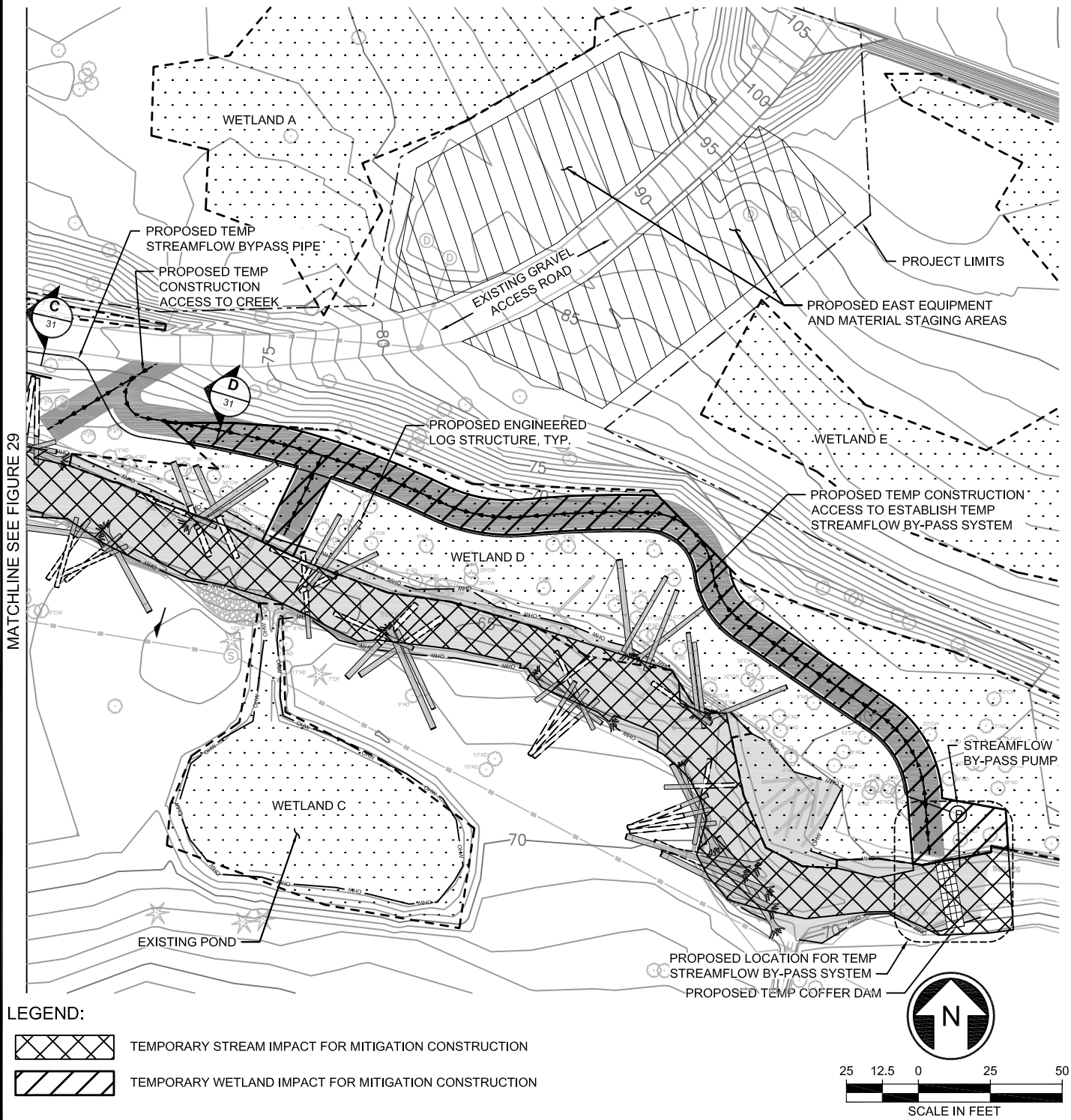

05/20/15 | 8:38 AM | TPRESOTT
C:\PROJ\2010\10-04788-040\CADD\DWG\CAR\FIG 30.DWG



EAST LINK EXTENSION
SOUTH BELLEVUE TO OVERLAKE TRANSIT CENTER
 APPENDIX C
 FIGURE 30
 WETLAND, STREAM, AND BUFFER MITIGATION PLANS

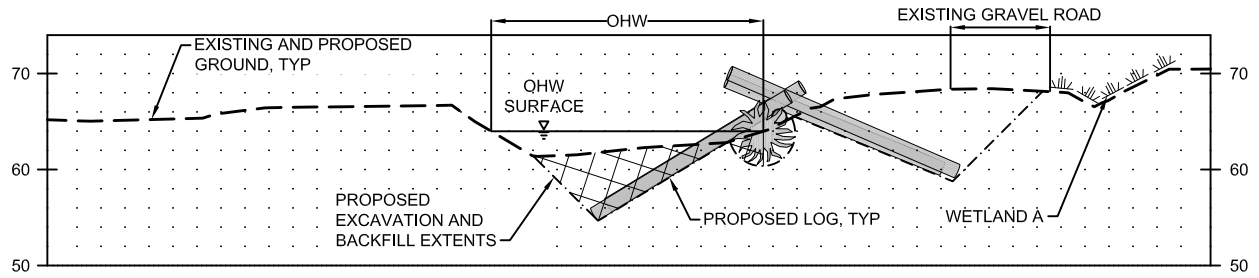

A
29

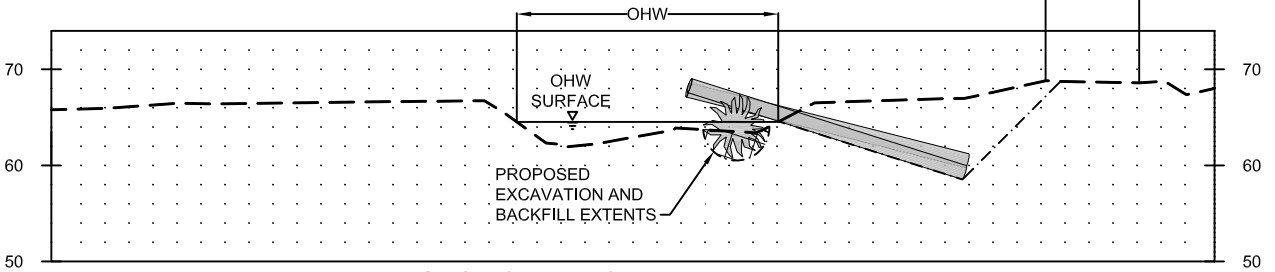

B
29

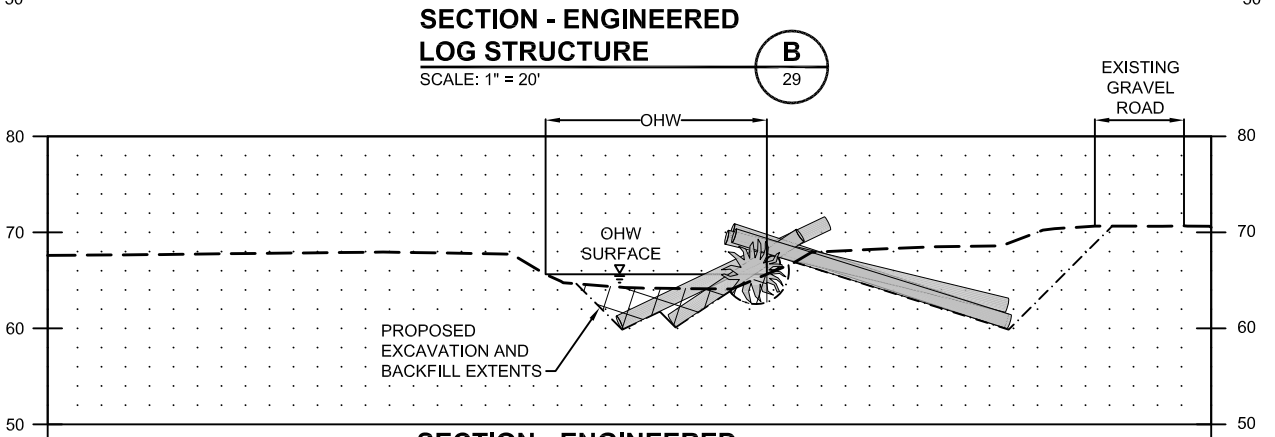

C
30

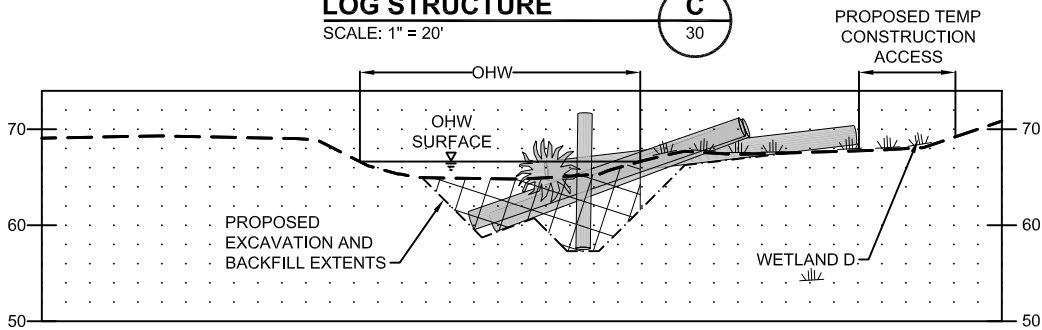

D
30

LEGEND:

- EXISTING AND PROPOSED GROUND
- - - - PROPOSED EXCAVATION AND BACKFILL EXTENTS
- ||||| EXISTING WETLAND
- ▧ TEMPORARY STREAM IMPACT FOR LOG PLACEMENT





05/20/15 | 8:41 AM | TPRESCOTT
C:\PROJ\2010\10-04788-04\0\CADD\DWG\CAR\FIG 31.DWG

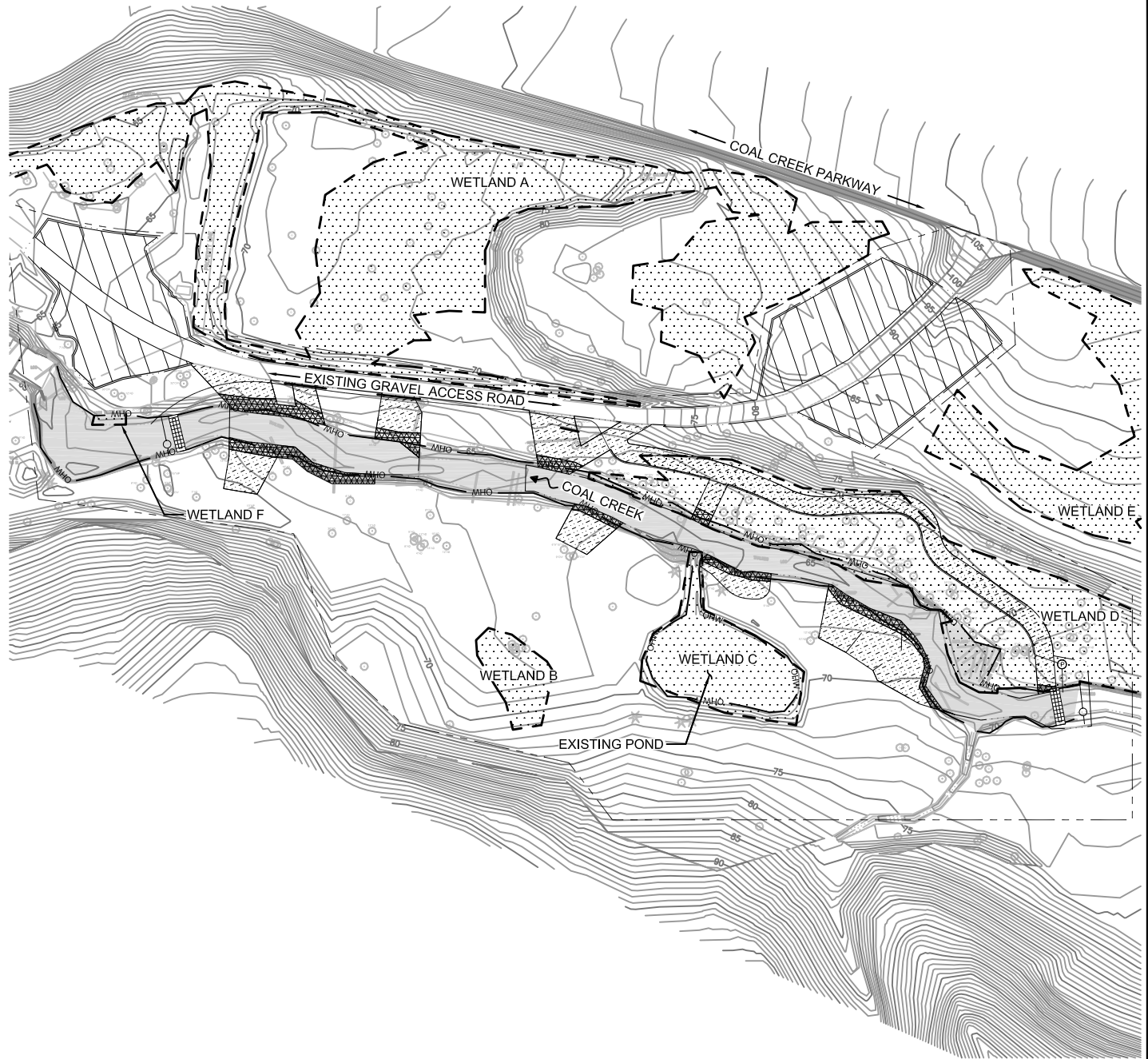



LEGEND:

-  PROPOSED RIPARIAN PLANT ZONES (WETLAND AND BUFFER RESTORATION)
-  PROPOSED STREAMBANK PLANTING ZONES

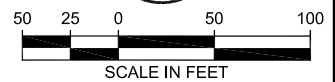

05/20/15 | 8:44 AM | TPRESOCTT
 C:\PROJ\2010\10-04788-040\CADD\DWG\CAR\FIG 32.DWG



EAST LINK EXTENSION
SOUTH BELLEVUE TO OVERLAKE TRANSIT CENTER
 APPENDIX C
 FIGURE 32
 WETLAND, STREAM, AND BUFFER MITIGATION PLANS

Appendix D

Proposed Mitigation and Restoration Design

08/27/14 | 11:59 AM | J.LOGAN
 J:\55229\CADD\501\DRAWINGS\ARCH\CRITICAL AREAS REPORT\MITIGATION_PLANTING\FIG-320-L85-CAR200.DWG

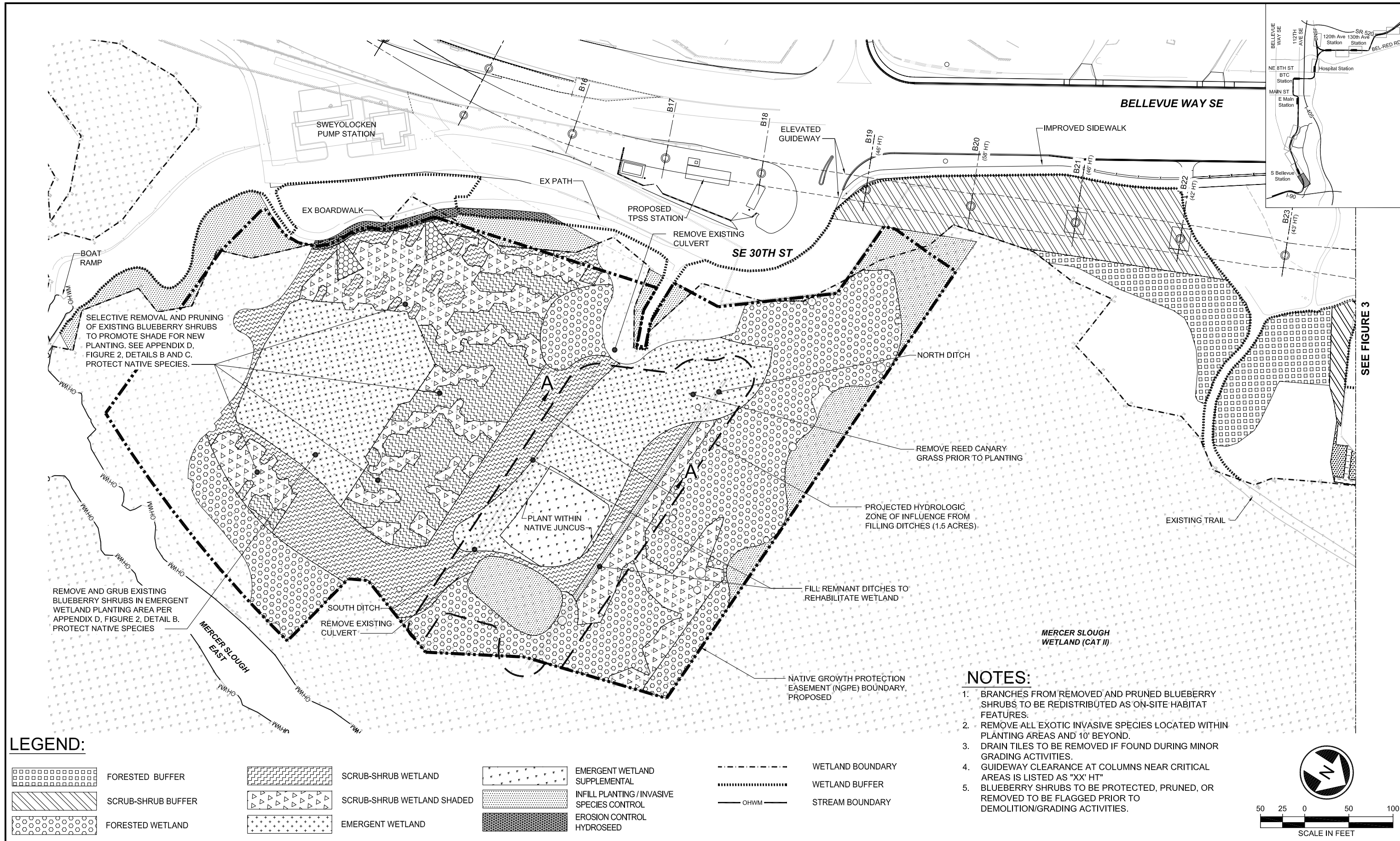

SEE FIGURE 3

LEGEND:

	FORESTED BUFFER		SCRUB-SHRUB WETLAND		EMERGENT WETLAND SUPPLEMENTAL		WETLAND BOUNDARY
	SCRUB-SHRUB BUFFER		SCRUB-SHRUB WETLAND SHADED		INFILL PLANTING / INVASIVE SPECIES CONTROL		WETLAND BUFFER
	FORESTED WETLAND		EMERGENT WETLAND		EROSION CONTROL HYDROSEED		STREAM BOUNDARY

NOTES:

- BRANCHES FROM REMOVED AND PRUNED BLUEBERRY SHRUBS TO BE REDISTRIBUTED AS ON-SITE HABITAT FEATURES.
- REMOVE ALL EXOTIC INVASIVE SPECIES LOCATED WITHIN PLANTING AREAS AND 10' BEYOND.
- DRAIN TILES TO BE REMOVED IF FOUND DURING MINOR GRADING ACTIVITIES.
- GUIDEWAY CLEARANCE AT COLUMNS NEAR CRITICAL AREAS IS LISTED AS "XX' HT"
- BLUEBERRY SHRUBS TO BE PROTECTED, PRUNED, OR REMOVED TO BE FLAGGED PRIOR TO DEMOLITION/GRADING ACTIVITIES.

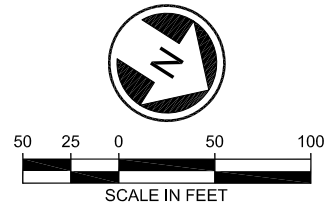

EAST LINK EXTENSION
 SOUTH BELLEVUE TO OVERLAKE TRANSIT CENTER
 APPENDIX D
 FIGURE 1
 MITIGATION AND RESTORATION PLANTING PLANS

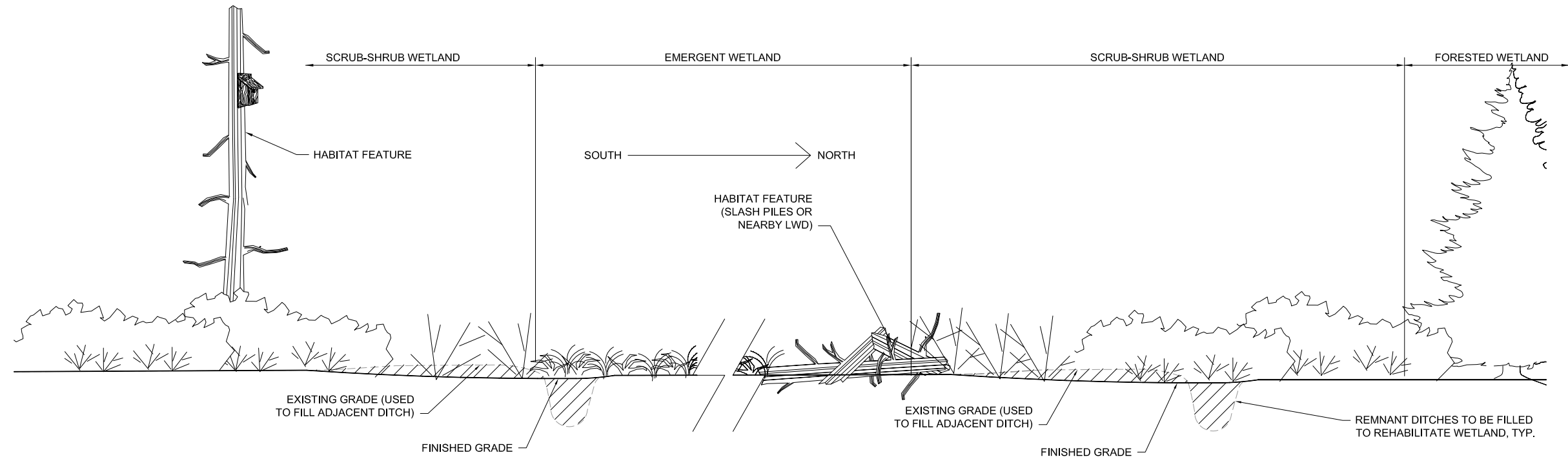

SECTION AT SWEYLOCKEN **A**
SCALE: NTS

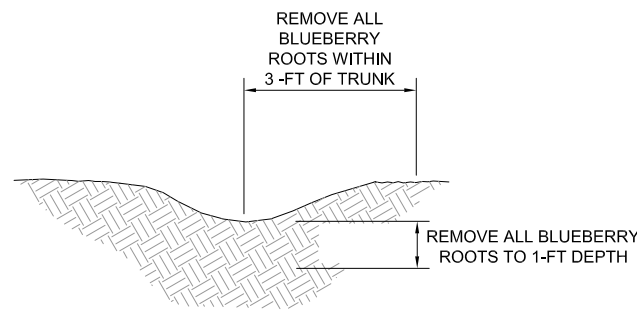

REMOVE AND GRUB BLUEBERRY SHRUB **B**
SCALE: NTS

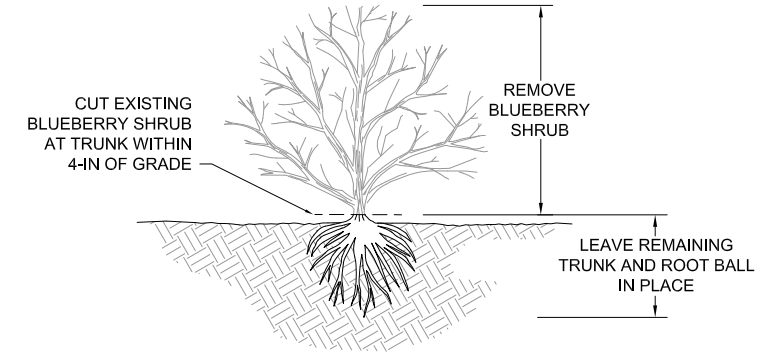

CUT BACK BLUEBERRY SHRUB **C**
SCALE: NTS

NOTES:

- BRANCHES FROM REMOVED AND PRUNED BLUEBERRY SHRUBS TO BE REDISTRIBUTED AS ON-SITE HABITAT FEATURES.
- BLUEBERRY SHRUBS TO BE PROTECTED, PRUNED, OR REMOVED TO BE FLAGGED PRIOR TO DEMOLITION/GRADING ACTIVITIES.

08/27/14 | 1:42 PM | JLOGAN | J:\55229\CADD\501\DRAWINGS\SLARCH\CRITICAL AREAS REPORT\MITIGATION_PLANTING\DETAILS-CAR200.DWG

08/27/14 | 12:04 PM | J.LOGAN
 J:\55229\CADD\501\DRAWINGS\LARCH\CRITICAL AREAS REPORT\MITIGATION_PLANTING\E-320-L85-CAR200.DWG

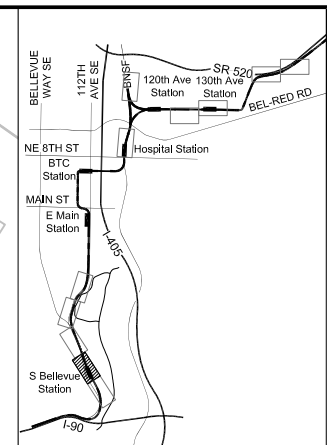
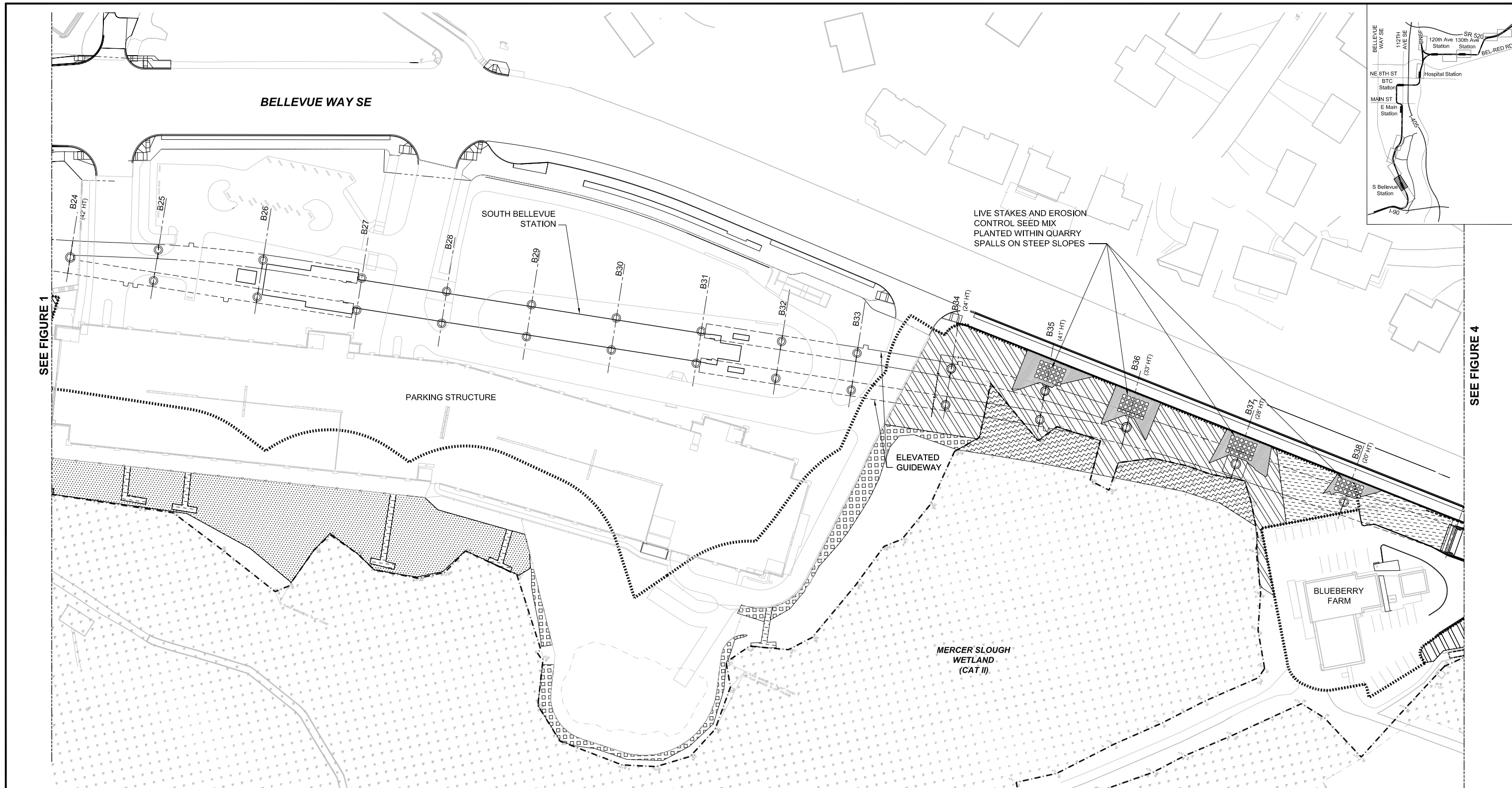

SEE FIGURE 1

SEE FIGURE 4

LEGEND:

- | | | | | | |
|--|--------------------------|--|--|--|------------------|
| | FORESTED BUFFER | | SCRUB-SHRUB WETLAND | | WETLAND BOUNDARY |
| | SCRUB-SHRUB BUFFER | | INFILL PLANTING / INVASIVE SPECIES CONTROL | | WETLAND BUFFER |
| | SCRUB-SHRUB BUFFER - LOW | | | | |

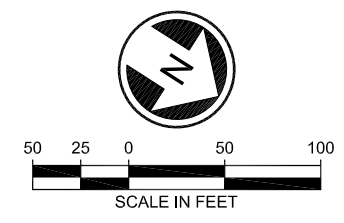

EAST LINK EXTENSION
 SOUTH BELLEVUE TO OVERLAKE TRANSIT CENTER
 APPENDIX D
 FIGURE 3
 MITIGATION AND RESTORATION PLANTING PLANS

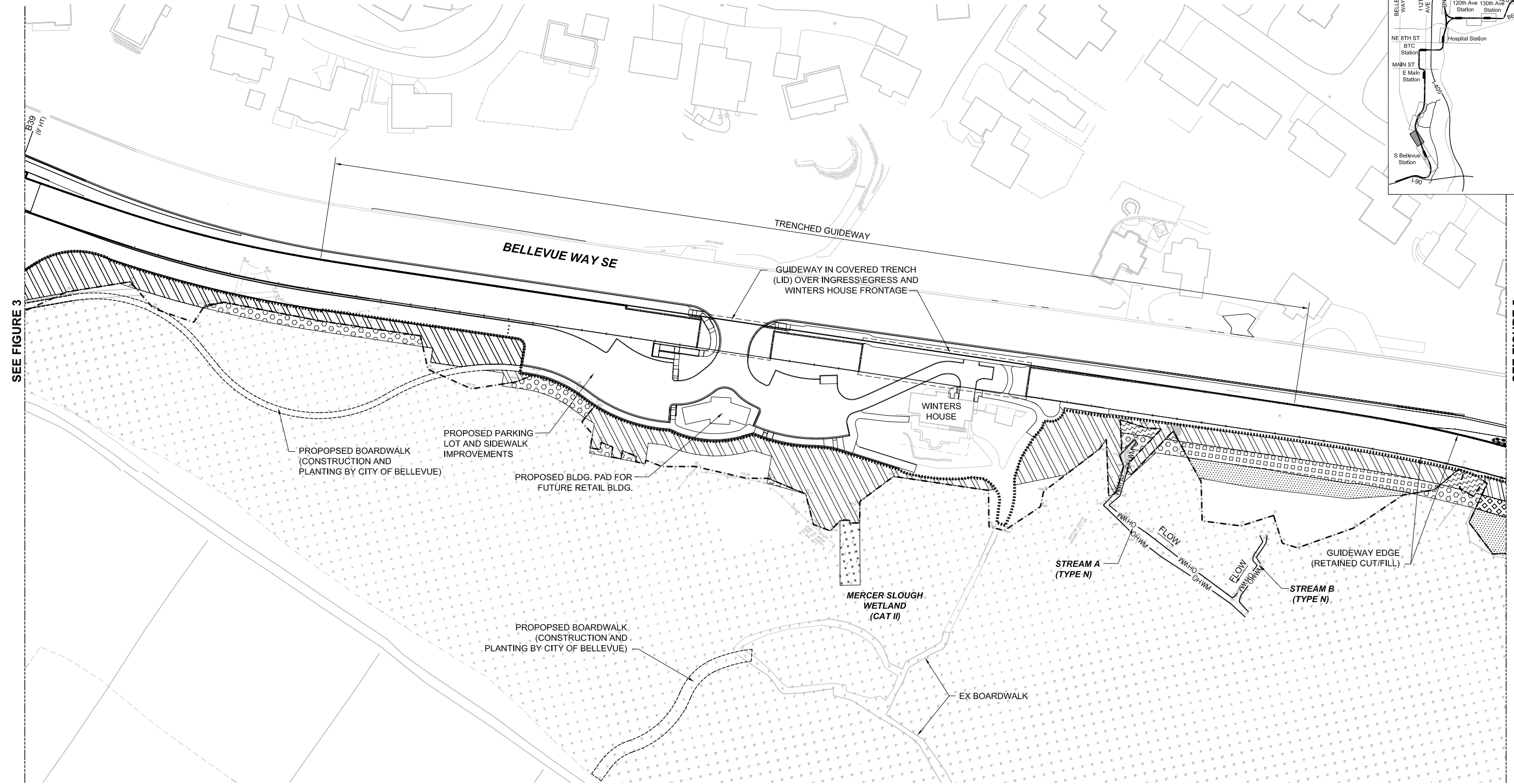
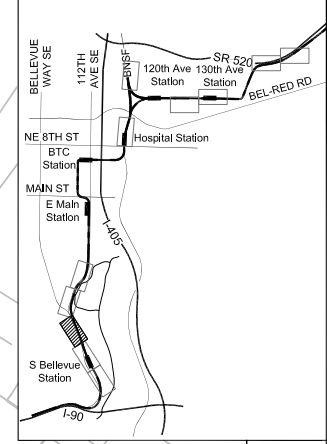

LEGEND:

	FORESTED BUFFER		SCRUB-SHRUB WETLAND		WETLAND BOUNDARY
	SCRUB-SHRUB BUFFER		EMERGENT WETLAND		WETLAND BUFFER
	FORESTED WETLAND		INFILL PLANTING / INVASIVE SPECIES CONTROL		STREAM BOUNDARY

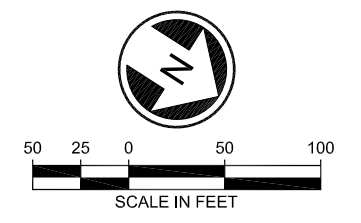

EAST LINK EXTENSION
 SOUTH BELLEVUE TO OVERLAKE TRANSIT CENTER
 APPENDIX D
 FIGURE 4
 MITIGATION AND RESTORATION PLANTING PLANS



08/27/14 | 12:05 PM | J.LOGAN | J:\55229\CADD\501\DRAWINGS\ARCH\CRITICAL AREAS REPORT\MITIGATION_PLANTING\E-320-L85-CAR200.DWG

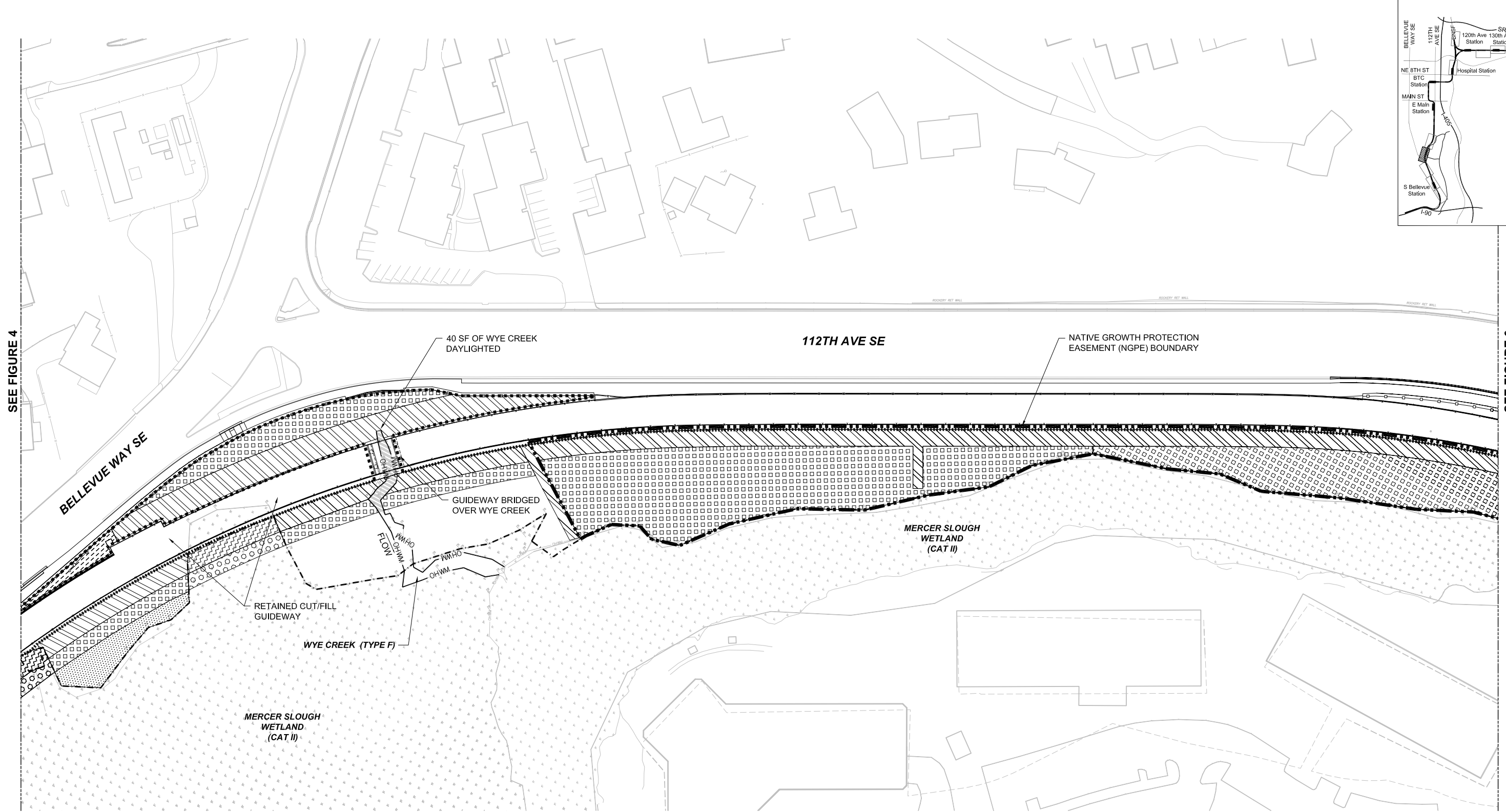
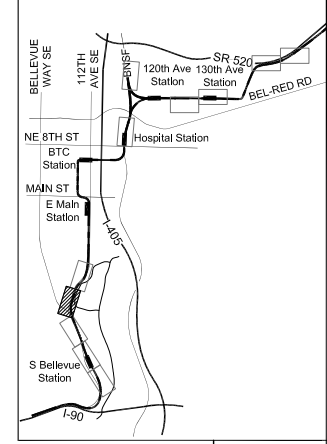

SEE FIGURE 4

SEE FIGURE 6

LEGEND:

	FORESTED BUFFER		FORESTED WETLAND		WETLAND BOUNDARY
	SCRUB-SHRUB BUFFER		SCRUB-SHRUB WETLAND		WETLAND BUFFER
	SCRUB-SHRUB BUFFER - LOW		INFILL PLANTING / INVASIVE SPECIES CONTROL		STREAM BOUNDARY
					STREAM BUFFER

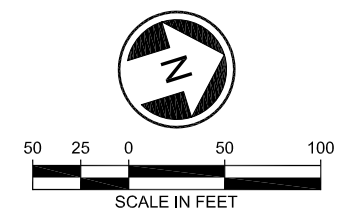

08/27/14 | 12:07 PM | J.LOGAN
J:\55229\CADD\DS01\DRAWINGS\ARCH\CRITICAL AREAS REPORT\MITIGATION_PLANTING\E-320-L85-CAR200.DWG



EAST LINK EXTENSION
SOUTH BELLEVUE TO OVERLAKE TRANSIT CENTER
APPENDIX D
FIGURE 5
MITIGATION AND RESTORATION PLANTING PLANS

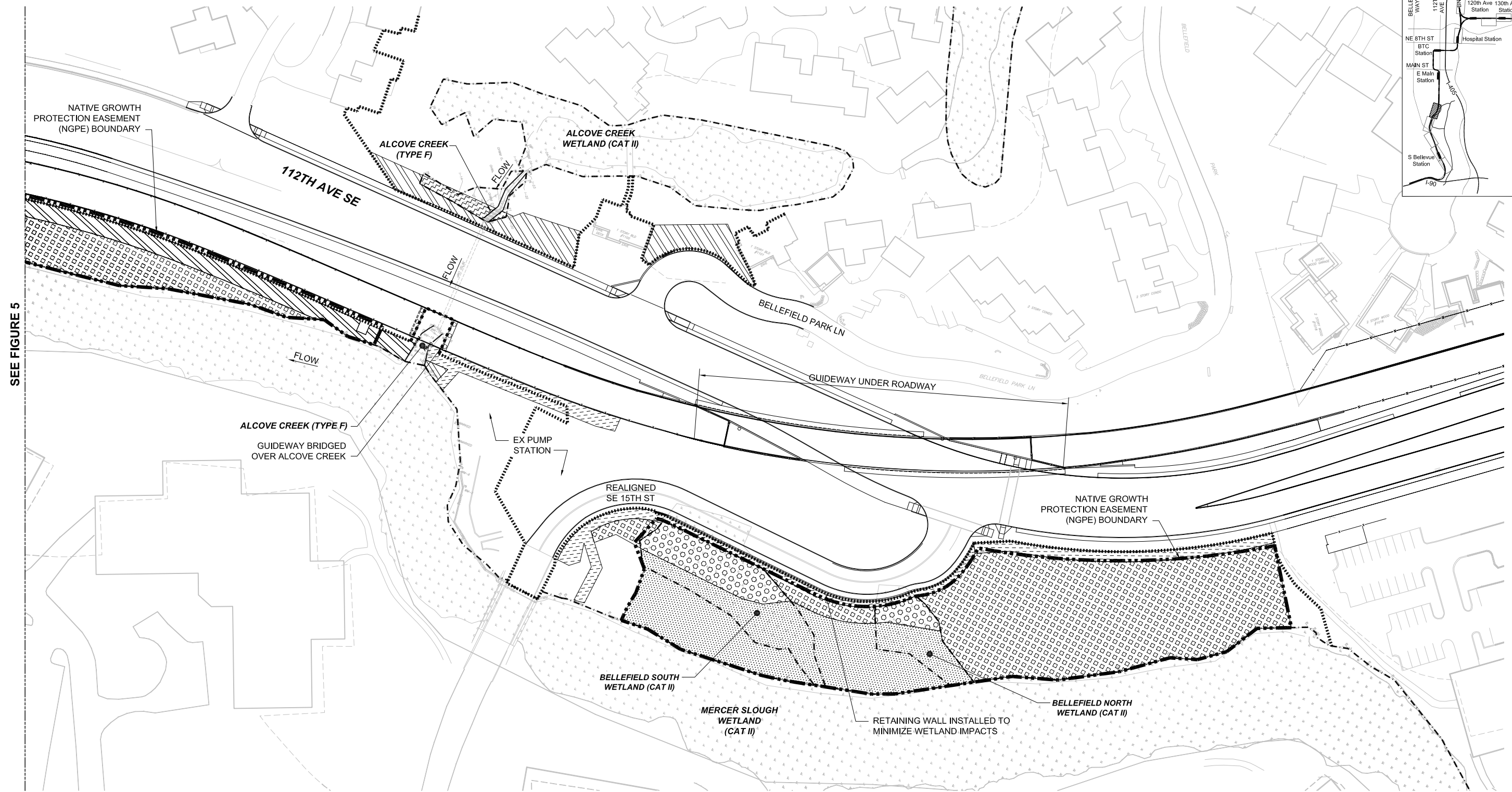
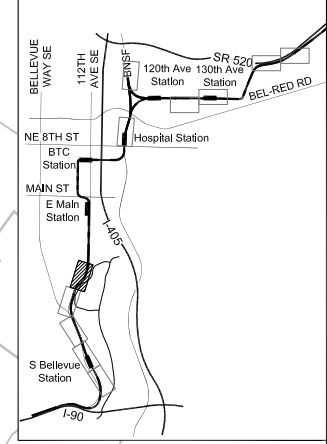

SEE FIGURE 5

LEGEND:

- | | | | | | |
|--|--------------------------|--|--|--|------------------|
| | FORESTED BUFFER | | FORESTED WETLAND | | WETLAND BOUNDARY |
| | SCRUB-SHRUB BUFFER | | SCRUB-SHRUB WETLAND | | WETLAND BUFFER |
| | SCRUB-SHRUB BUFFER - LOW | | INFILL PLANTING / INVASIVE SPECIES CONTROL | | STREAM BOUNDARY |
| | | | | | STREAM BUFFER |

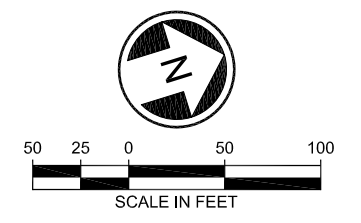

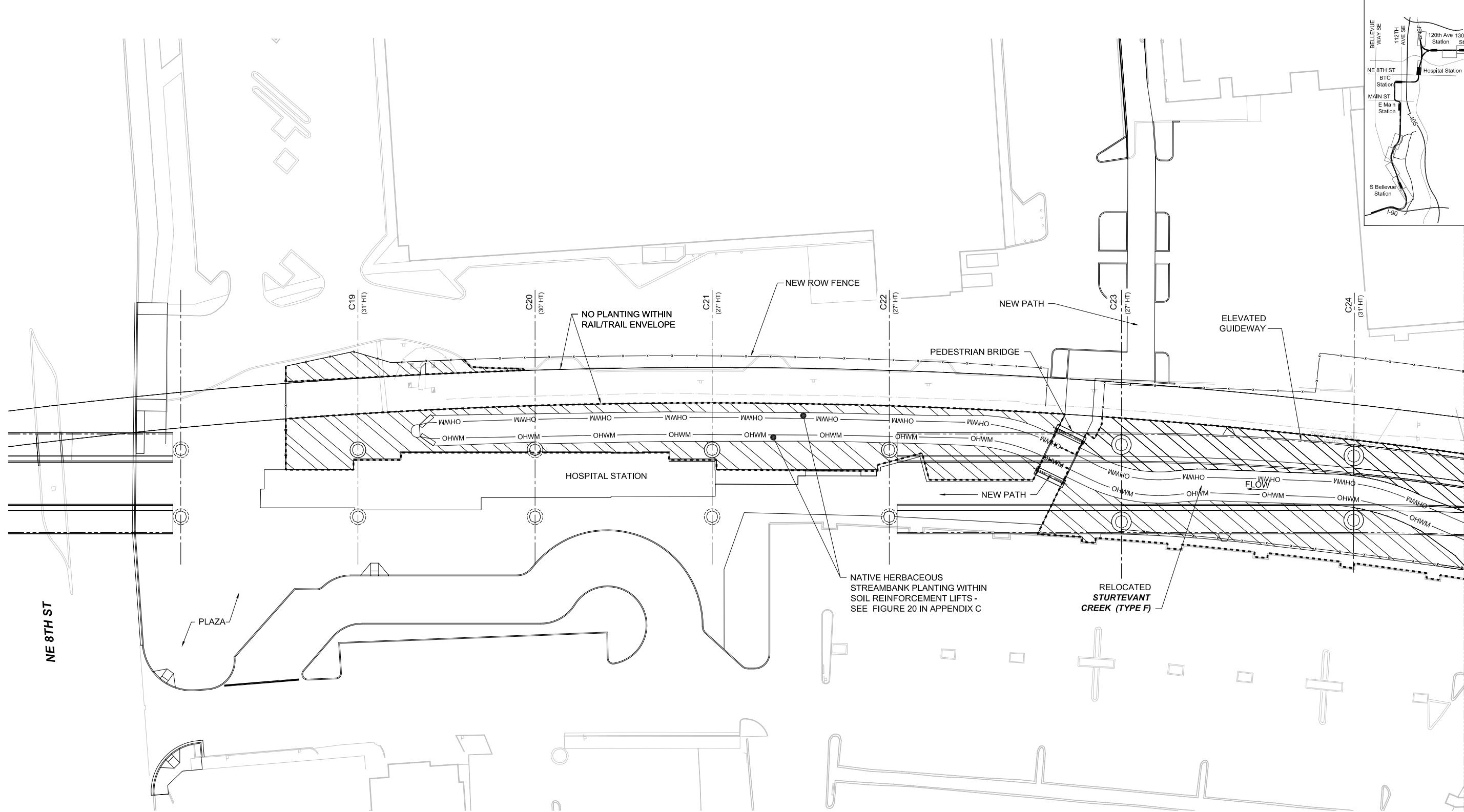
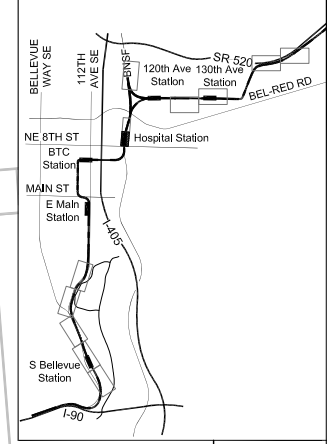

EAST LINK EXTENSION
 SOUTH BELLEVUE TO OVERLAKE TRANSIT CENTER
 APPENDIX D
 FIGURE 6
 MITIGATION AND RESTORATION PLANTING PLANS

08/27/14 | 12:10 PM | J.LOGAN | J:\5229\CADD\501\DRAWINGS\ARCH\CRITICAL AREAS REPORT\MITIGATION_PLANTING\E-320-L85-CAR200.DWG



SEE FIGURE 8

LEGEND:

-  SCRUB-SHRUB BUFFER
-  OHWM STREAM BOUNDARY
-  STREAM BUFFER

NOTES:

1. GUIDEWAY CLEARANCE AT COLUMNS NEAR CRITICAL AREAS IS LISTED AS "XX" HT.

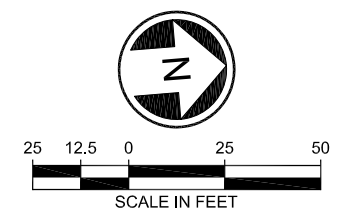

EAST LINK EXTENSION
 SOUTH BELLEVUE TO OVERLAKE TRANSIT CENTER
 APPENDIX D
 FIGURE 7
 MITIGATION AND RESTORATION PLANTING PLANS

08/28/14 | 8:07 AM | JLOGAN | J:\5229\CADD\DS01\DRAWINGS\ARCH\CRITICAL AREAS REPORT\MITIGATION_PLANTING\E-335-L86-CAR200.DWG

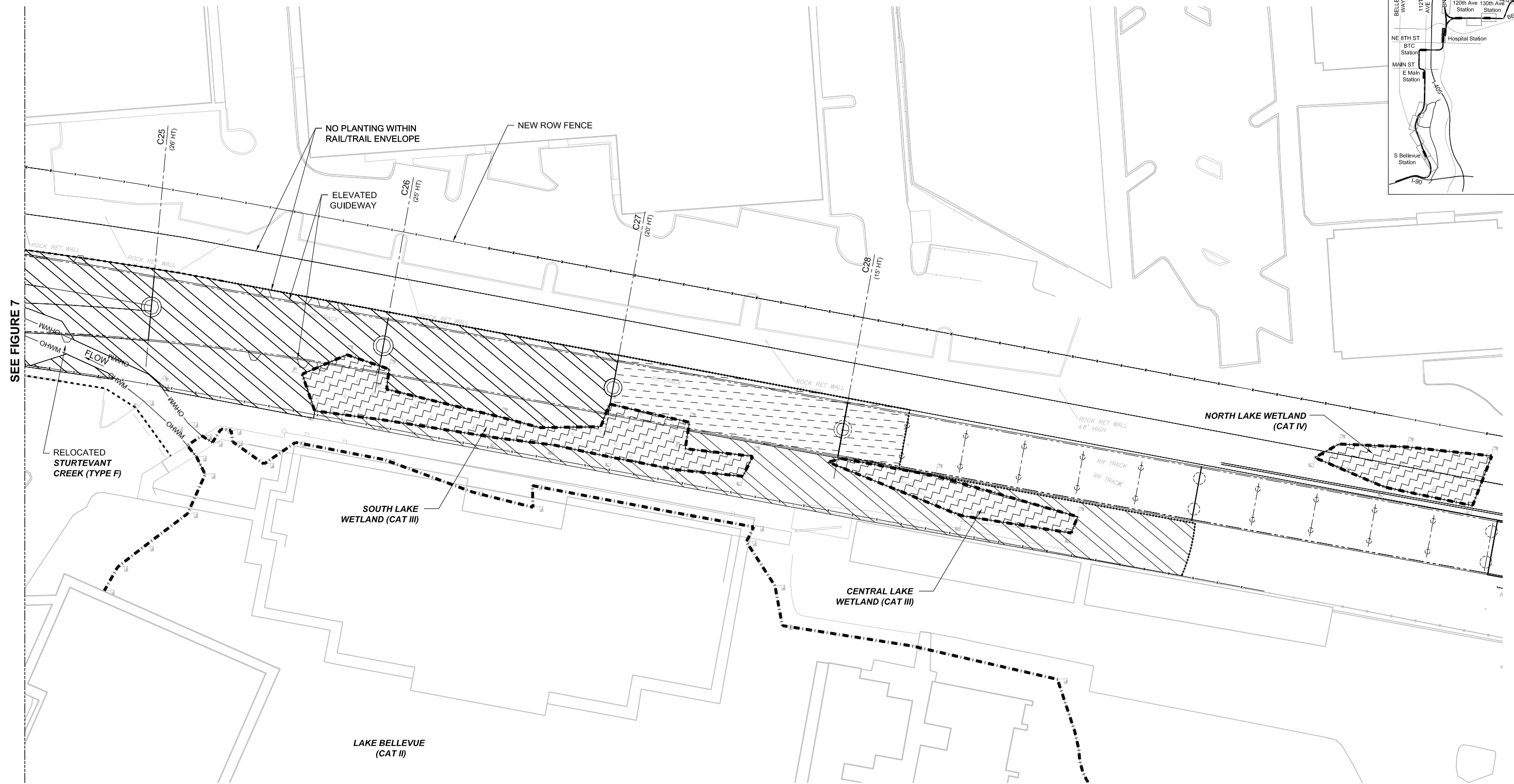
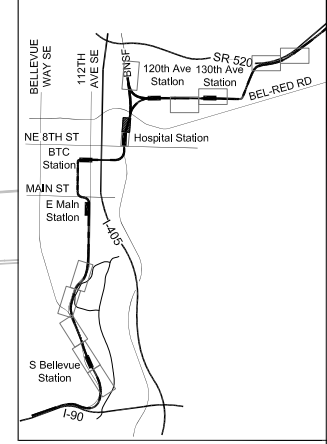

LEGEND:

	SCRUB-SHRUB BUFFER		WETLAND BOUNDARY
	SCRUB-SHRUB BUFFER - LOW		WETLAND BUFFER
	SCRUB-SHRUB WETLAND		OHWM
			STREAM BUFFER

NOTES:



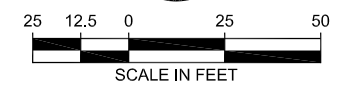

1. GUIDEWAY CLEARANCE AT COLUMNS NEAR CRITICAL AREAS IS LISTED AS "XX" HT.

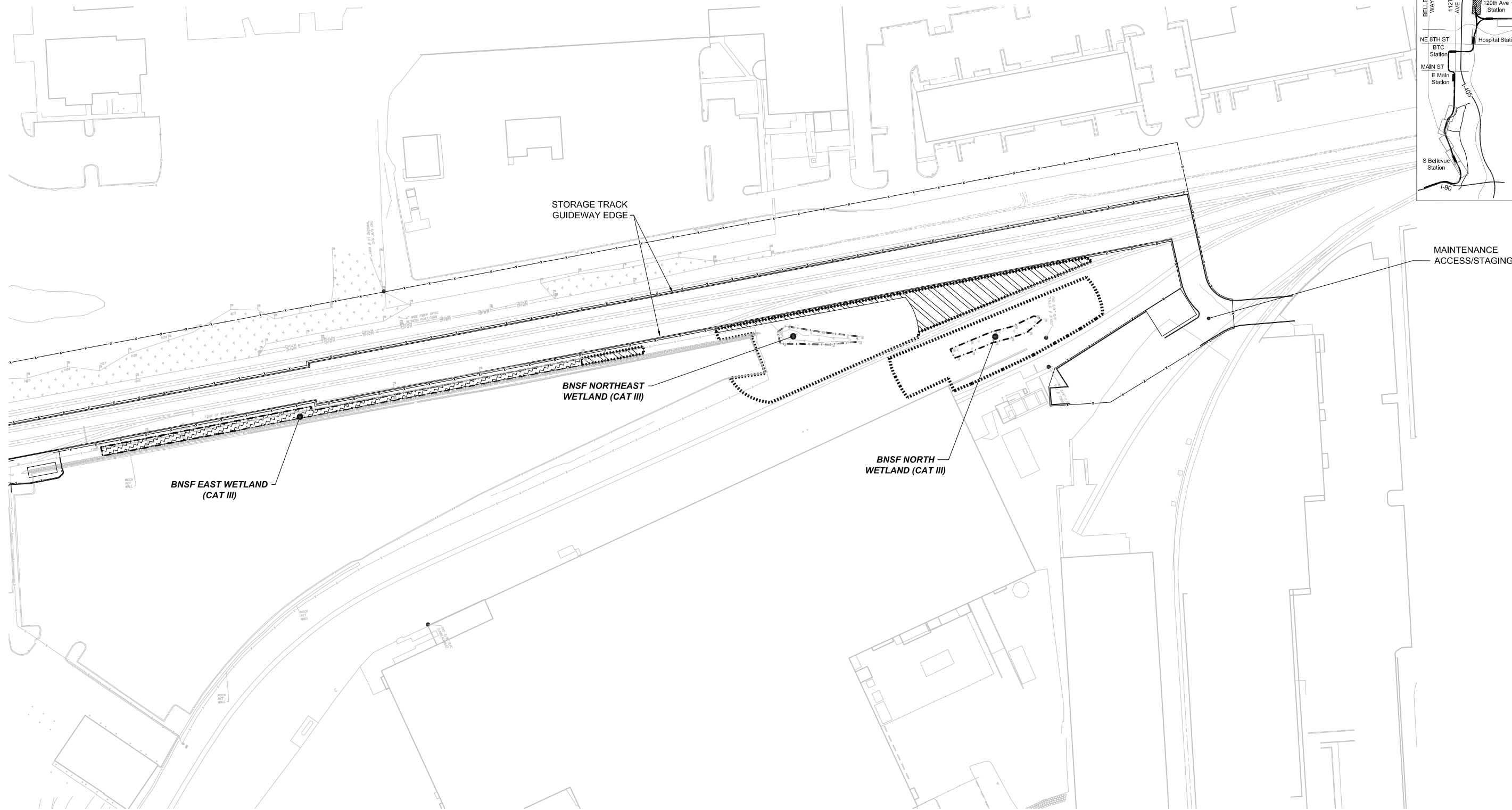
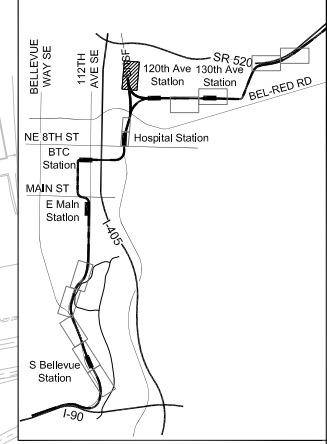

08/27/14 | 1:10 PM | JLOGAN | J:\55229\CADD\DS01\DRAWINGS\ARCH\CRITICAL AREAS REPORT\MITIGATION_PLANTING\335-L86-CAR200.DWG

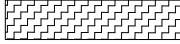

LEGEND:

- | | | | |
|---|---------------------|---|------------------|
|  | SCRUB-SHRUB BUFFER |  | WETLAND BUFFER |
|  | SCRUB-SHRUB WETLAND |  | WETLAND BOUNDARY |

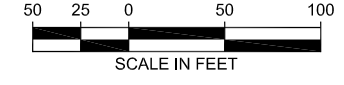





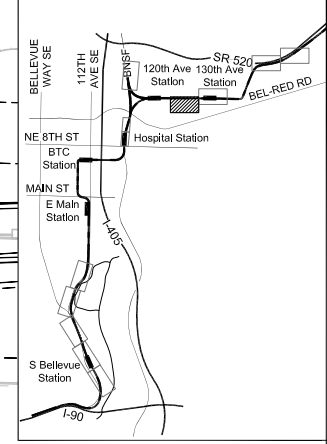
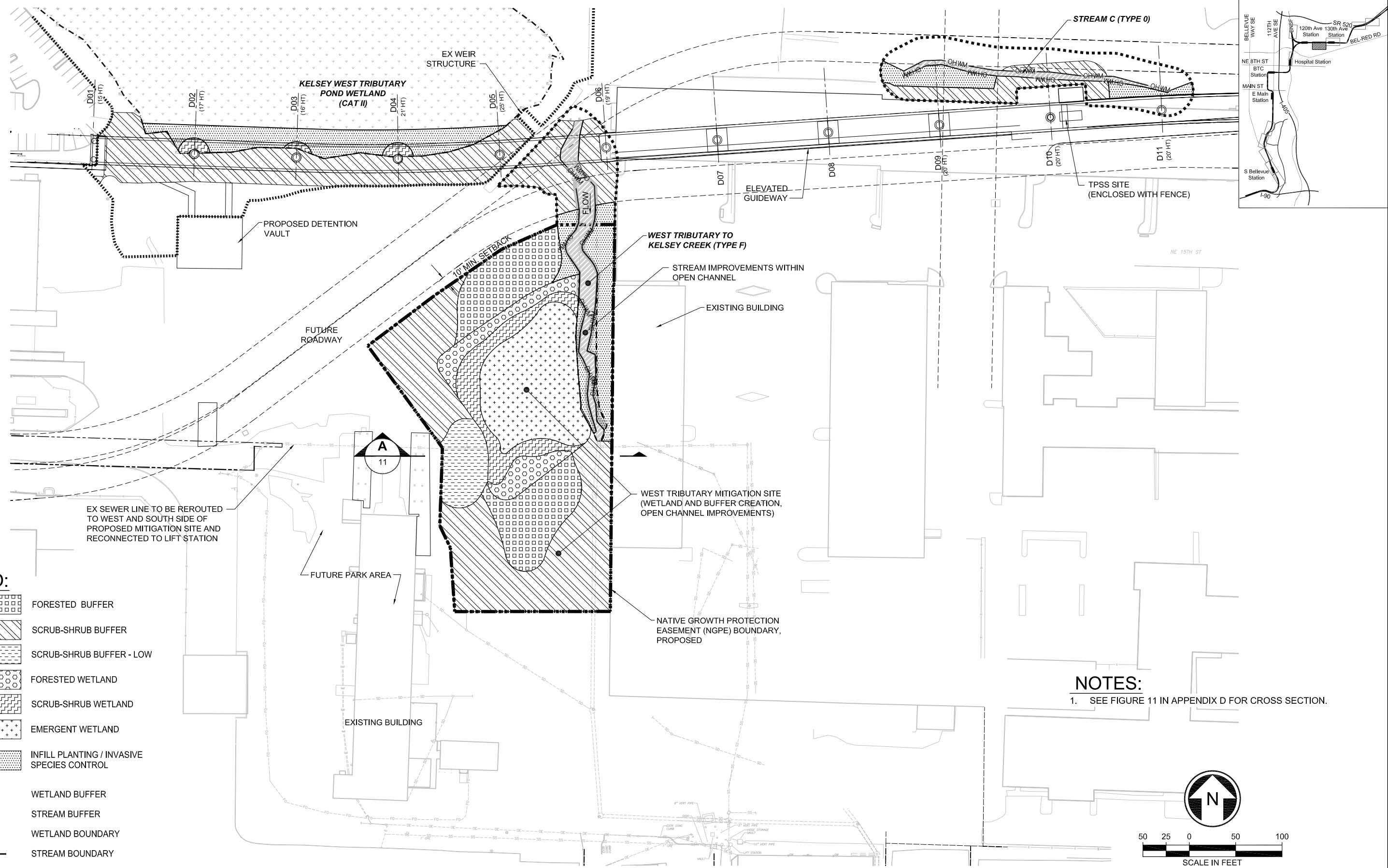

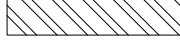

EAST LINK EXTENSION
 SOUTH BELLEVUE TO OVERLAKE TRANSIT CENTER
 APPENDIX D
 FIGURE 9
 MITIGATION AND RESTORATION PLANTING PLANS

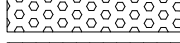
08/27/14 | 1:13 PM | JLOGAN | J:\55229\CADD\DS01\DRAWINGS\ARCH\CRITICAL AREAS REPORT\MITIGATION_PLANTING\E-340-L87-CAR200.DWG

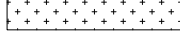

LEGEND:

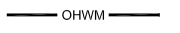
-  FORESTED BUFFER
-  SCRUB-SHRUB BUFFER
-  SCRUB-SHRUB BUFFER - LOW
-  FORESTED WETLAND
-  SCRUB-SHRUB WETLAND
-  EMERGENT WETLAND
-  INFILL PLANTING / INVASIVE SPECIES CONTROL
-  WETLAND BUFFER
-  STREAM BUFFER
-  WETLAND BOUNDARY
-  STREAM BOUNDARY

NOTES:

1. SEE FIGURE 11 IN APPENDIX D FOR CROSS SECTION.

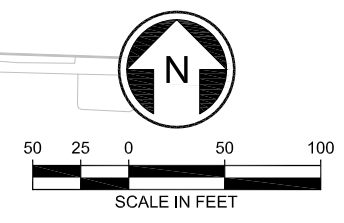

08/28/14 | 8:03 AM | JLOGAN | J:\55229\CADD\DS01\DRAWINGS\ARCH\CRITICAL AREAS REPORT\MITIGATION_PLANTING\340-L87-CAR200.DWG

08/27/14 | 1:48 PM | JLOGAN
J:\55229\CADD\DS01\DRAWINGS\LARCH\CRITICAL AREAS REPORT\MITIGATION_PLANTING\DETAILS-CAR200.DWG

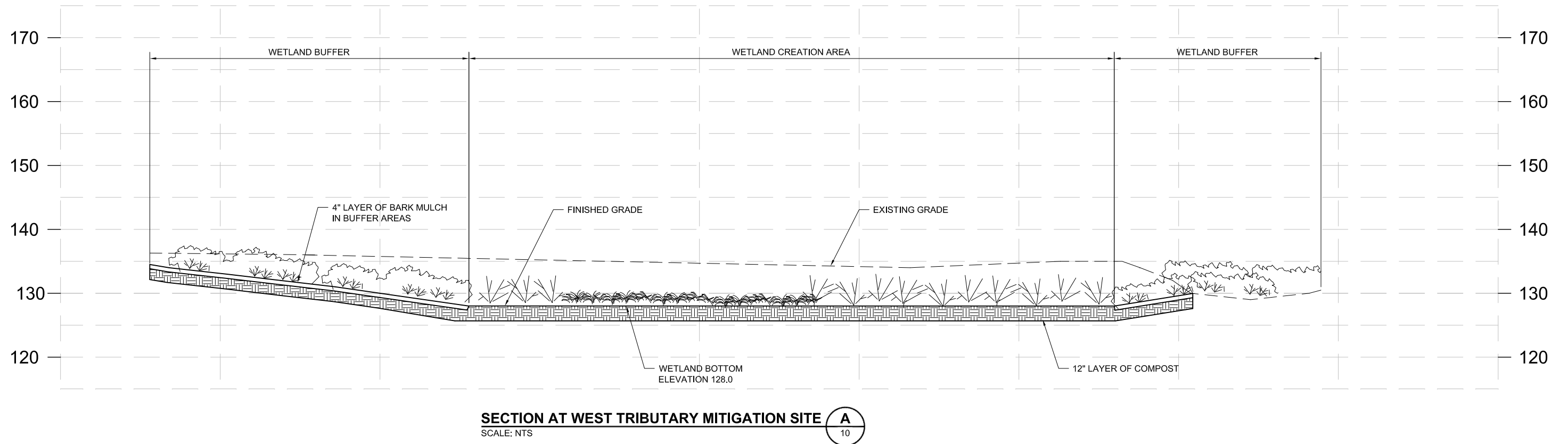

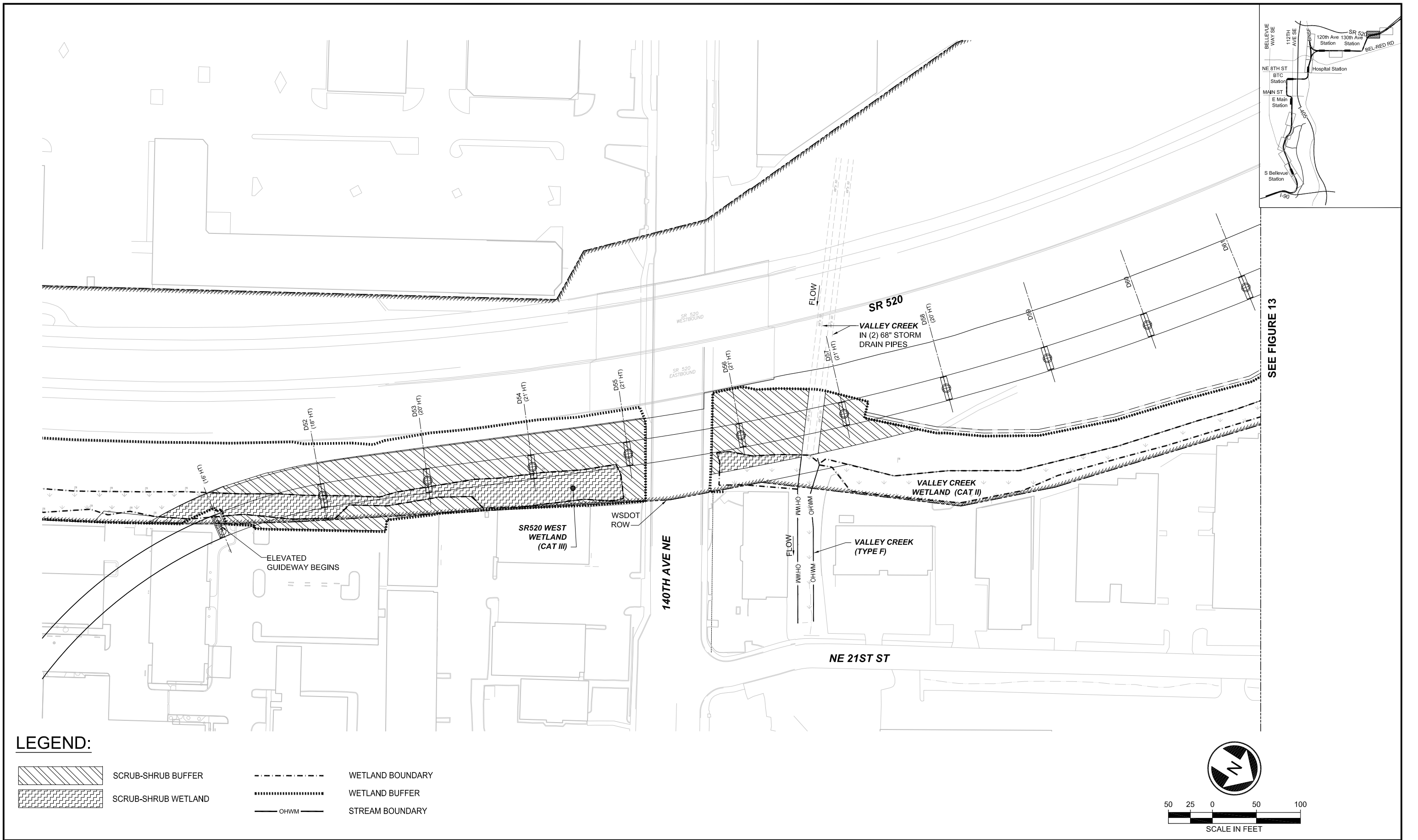

SECTION AT WEST TRIBUTARY MITIGATION SITE **A**
SCALE: NTS
10

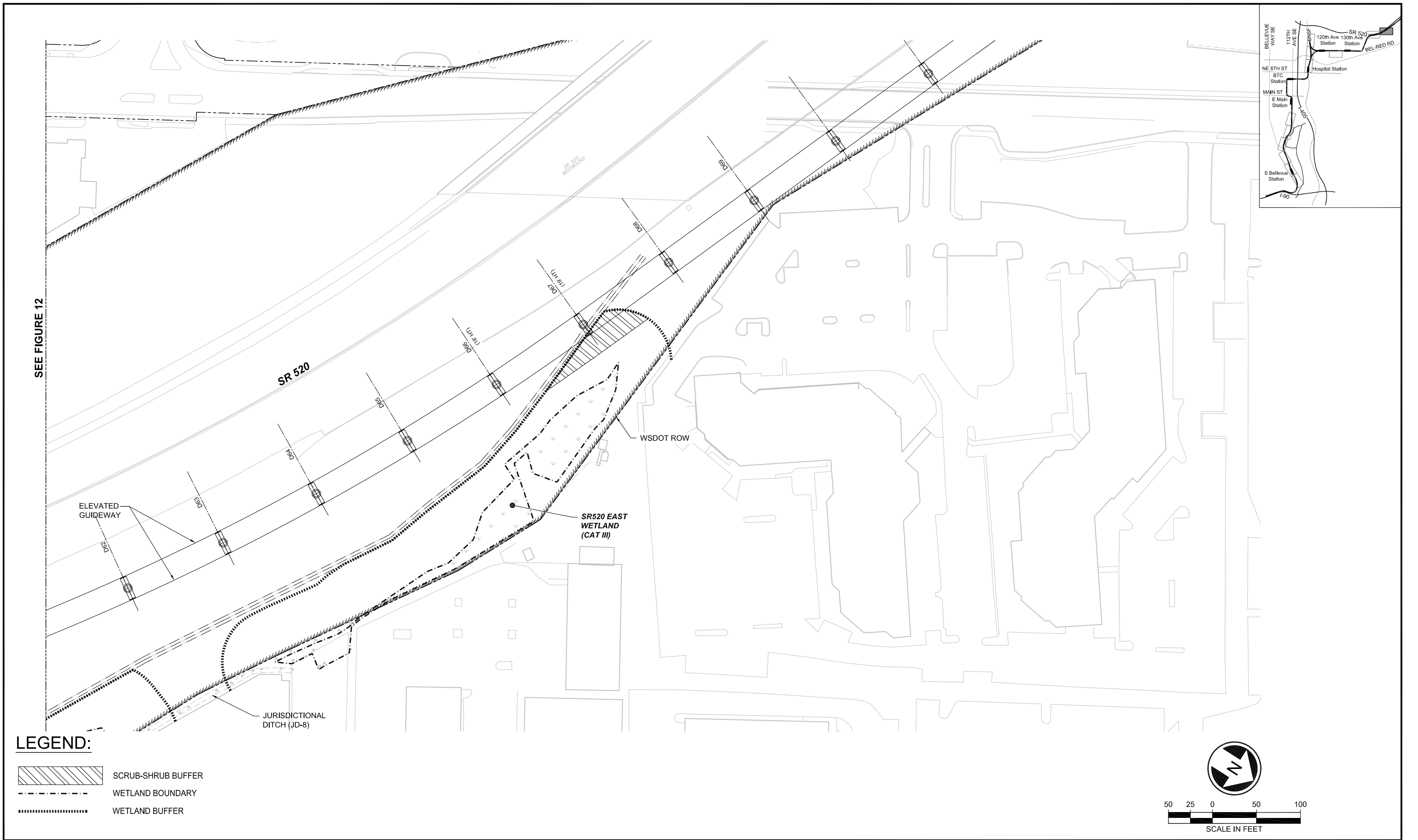



SEE FIGURE 12

LEGEND:

-  SCRUB-SHRUB BUFFER
-  WETLAND BOUNDARY
-  WETLAND BUFFER



Appendix E
Geologic Hazard Areas

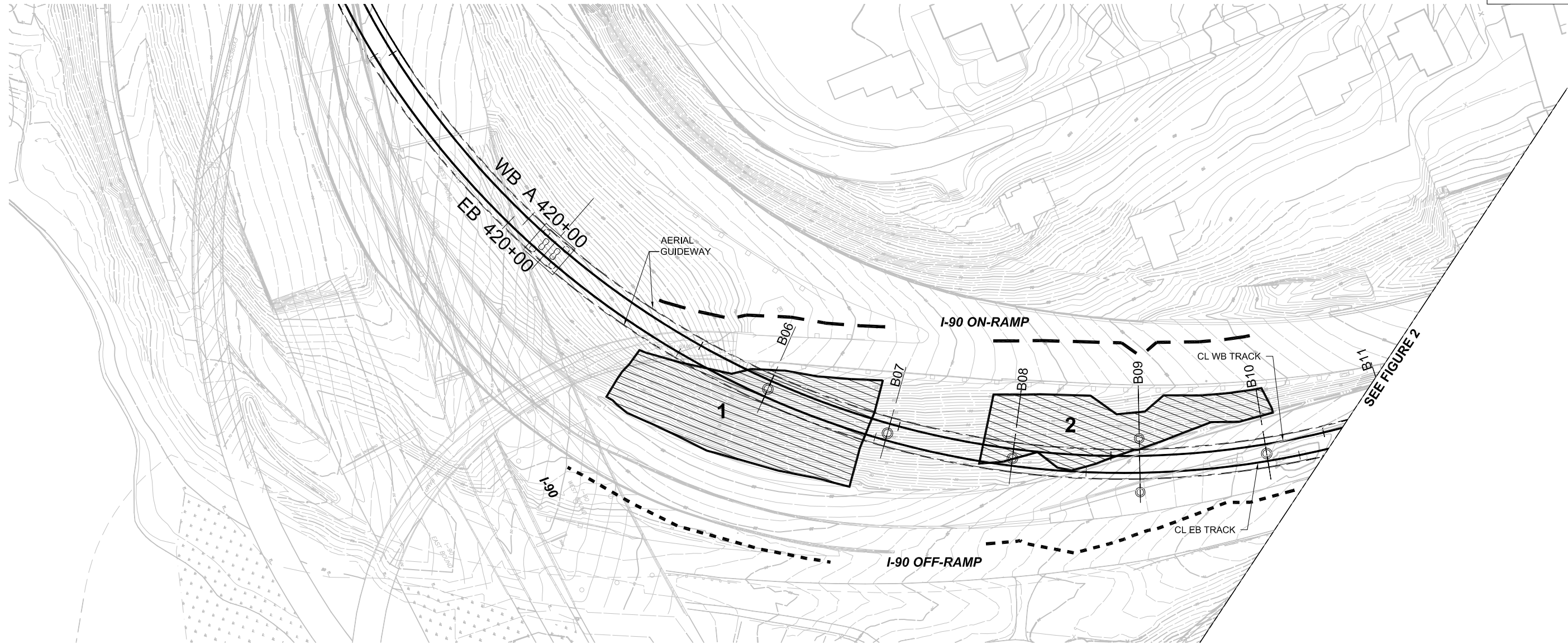
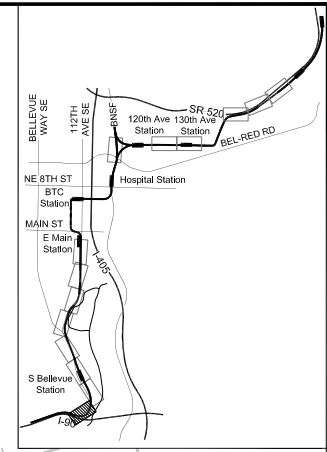

- LEGEND:**
-  STEEP SLOPE
 -  STEEP SLOPE CRITICAL AREA BUFFER
 -  STEEP SLOPE STRUCTURE SETBACK

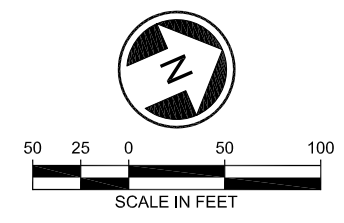

EAST LINK EXTENSION
 SOUTH BELLEVUE TO OVERLAKE TRANSIT CENTER
 APPENDIX E
 FIGURE 1
 GEOLOGIC HAZARD AREAS



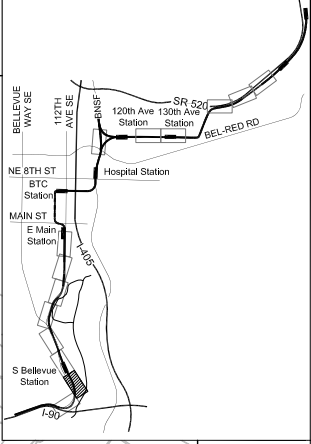
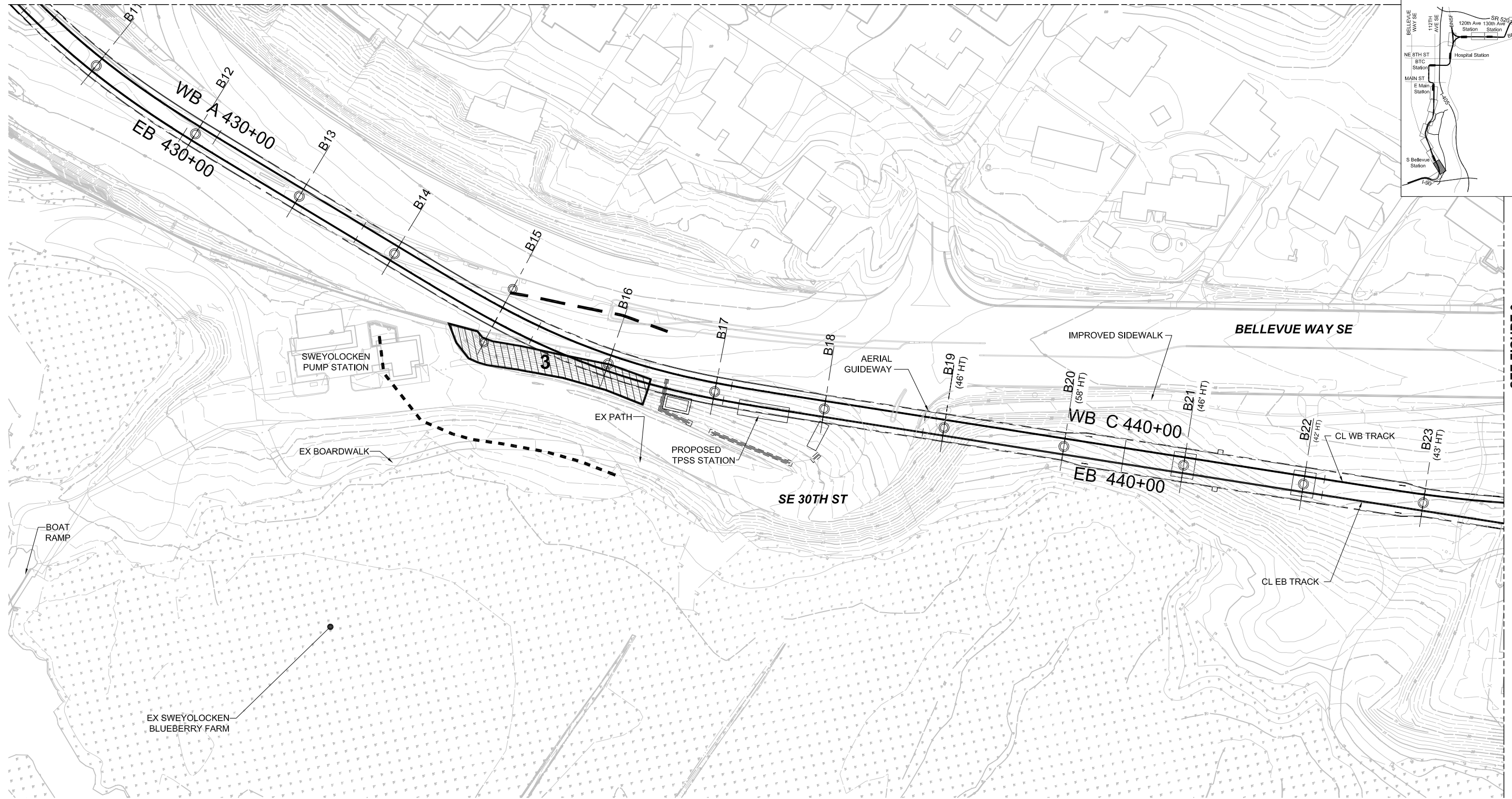

08/27/14 | 2:11 PM | JLOGAN
 J:\65229\CADD\SS\01DRAWINGS\ARCH\CRITICAL AREAS REPORT\GEOHAZARD\E-320-LB5-CAR101.DWG

SEE FIGURE 1

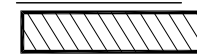

SEE FIGURE 3

LEGEND:

-  STEEP SLOPE
-  STEEP SLOPE CRITICAL AREA BUFFER
-  STEEP SLOPE STRUCTURE SETBACK

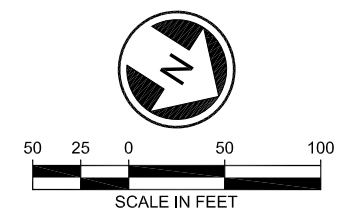

EAST LINK EXTENSION
 SOUTH BELLEVUE TO OVERLAKE TRANSIT CENTER
 APPENDIX E
 FIGURE 2
 GEOLOGIC HAZARD PLANS

08/27/14 | 2:19 PM | JLOGAN
 J:\65229\CADD\SS\01DRAWINGS\ARCH\CRITICAL AREAS REPORT\GEOHAZARD\E-320-LB5-CAR101.DWG

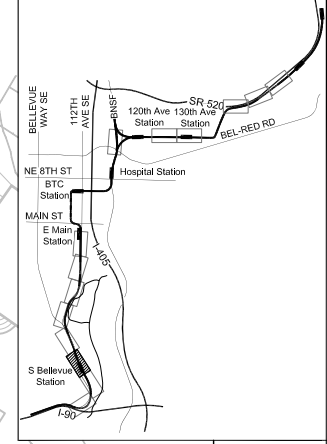
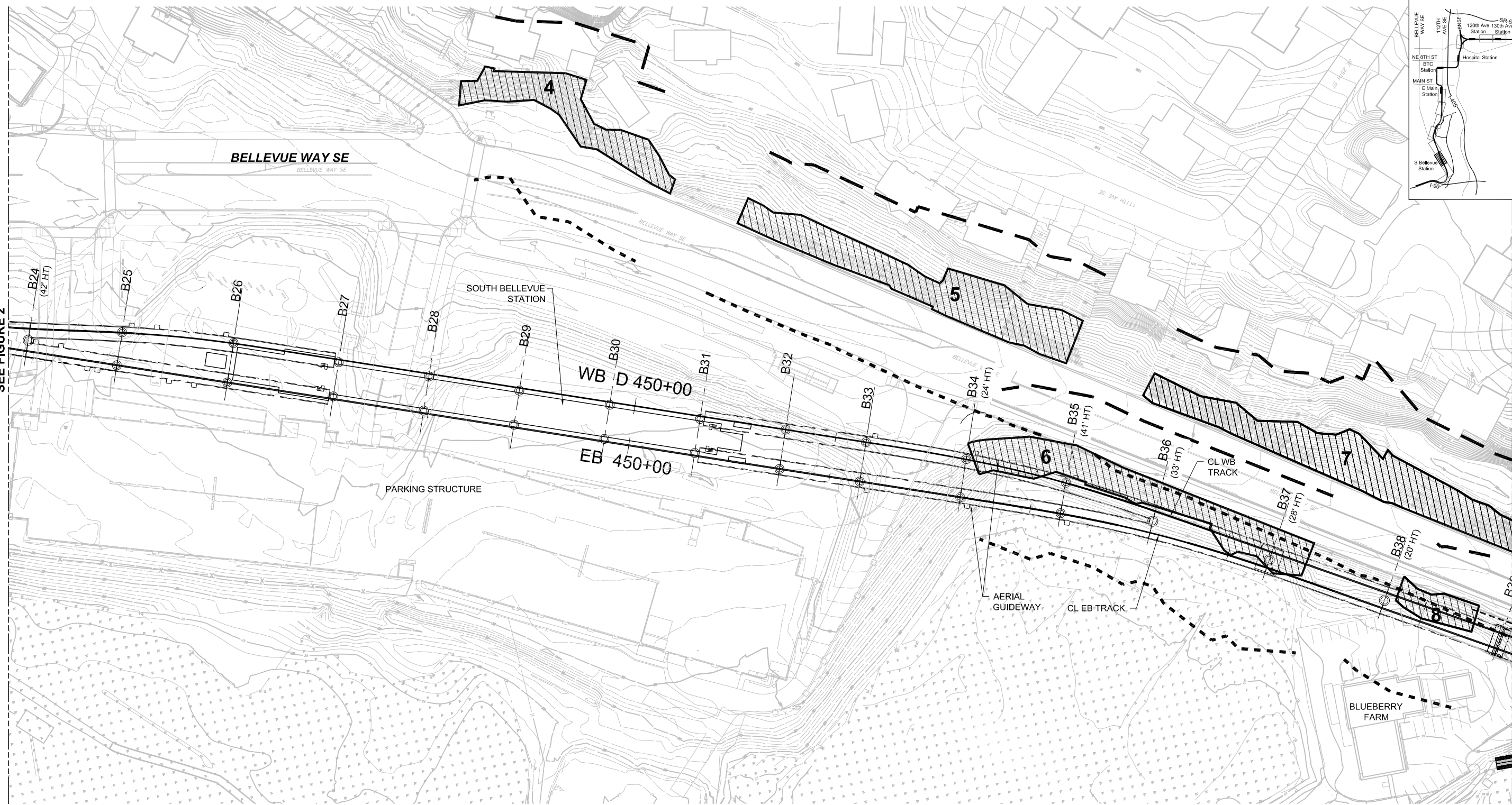

- LEGEND:**
-  STEEP SLOPE
 -  STEEP SLOPE CRITICAL AREA BUFFER
 -  STEEP SLOPE STRUCTURE SETBACK

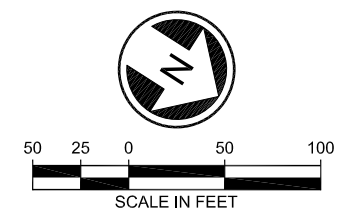

EAST LINK EXTENSION
 SOUTH BELLEVUE TO OVERLAKE TRANSIT CENTER
 APPENDIX E
 FIGURE 3
 GEOLOGIC HAZARD AREAS



08/27/14 | 2:19 PM | JLOGAN | J:\65229\CADD\SS\01DRAWINGS\ARCH\CRITICAL AREAS REPORT\GEOHAZARD\320-LB-CAR101.DWG

08/28/14 | 8:25 AM | JLOGAN
J:\65229\CADD\SS\01DRAWINGS\ARCH\CRITICAL AREAS REPORT\GEOHAZARD\320-LB5-CAR101.DWG

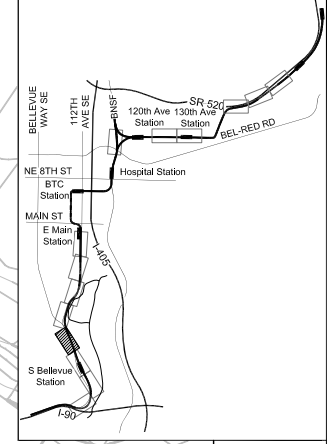
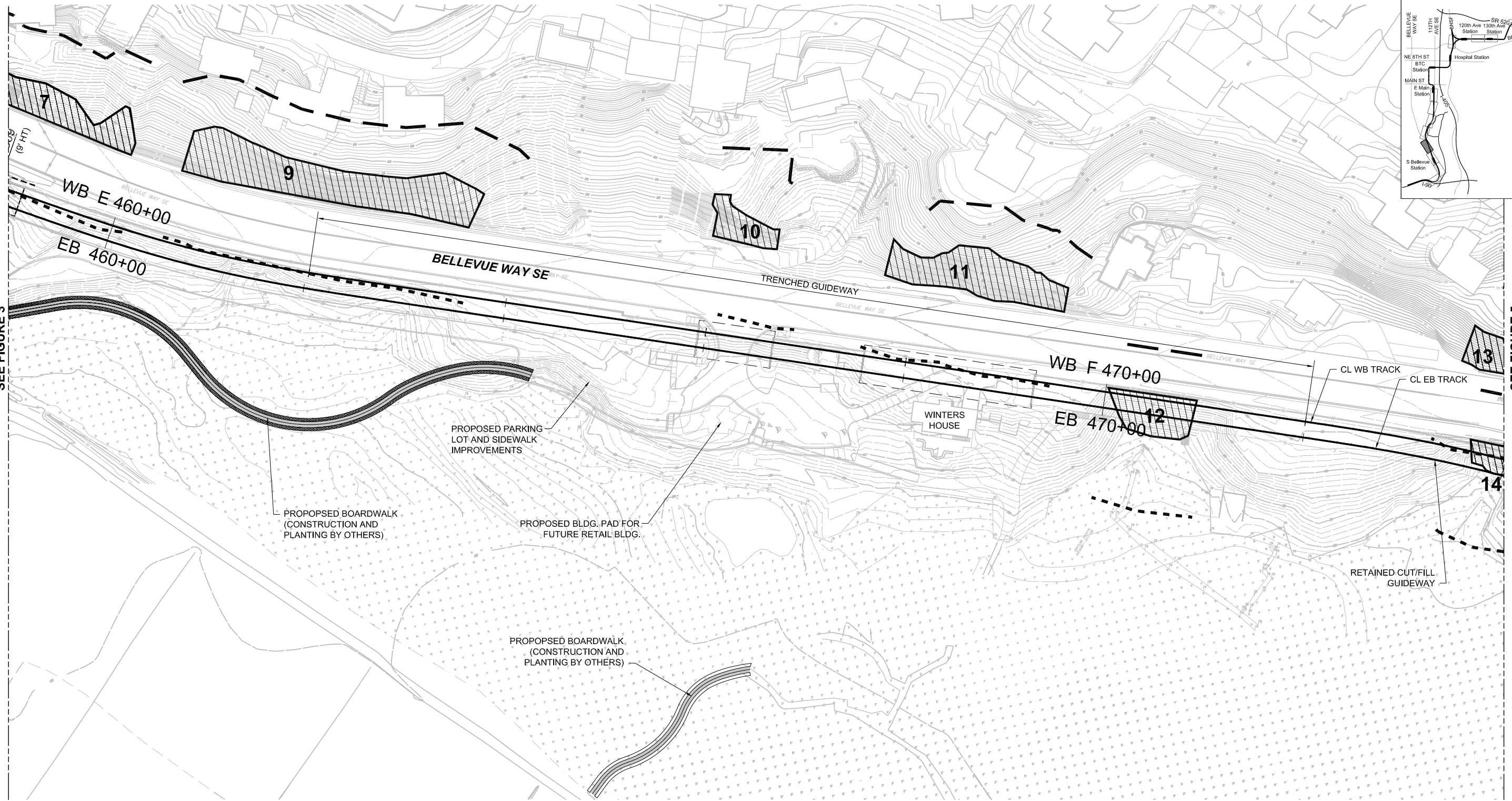

- LEGEND:**
-  STEEP SLOPE
 -  STEEP SLOPE CRITICAL AREA BUFFER
 -  STEEP SLOPE STRUCTURE SETBACK

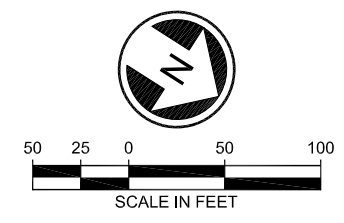

EAST LINK EXTENSION
 SOUTH BELLEVUE TO OVERLAKE TRANSIT CENTER
 APPENDIX E
 FIGURE 4
 GEOLOGIC HAZARD AREAS

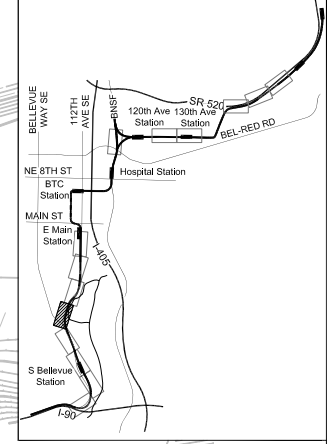
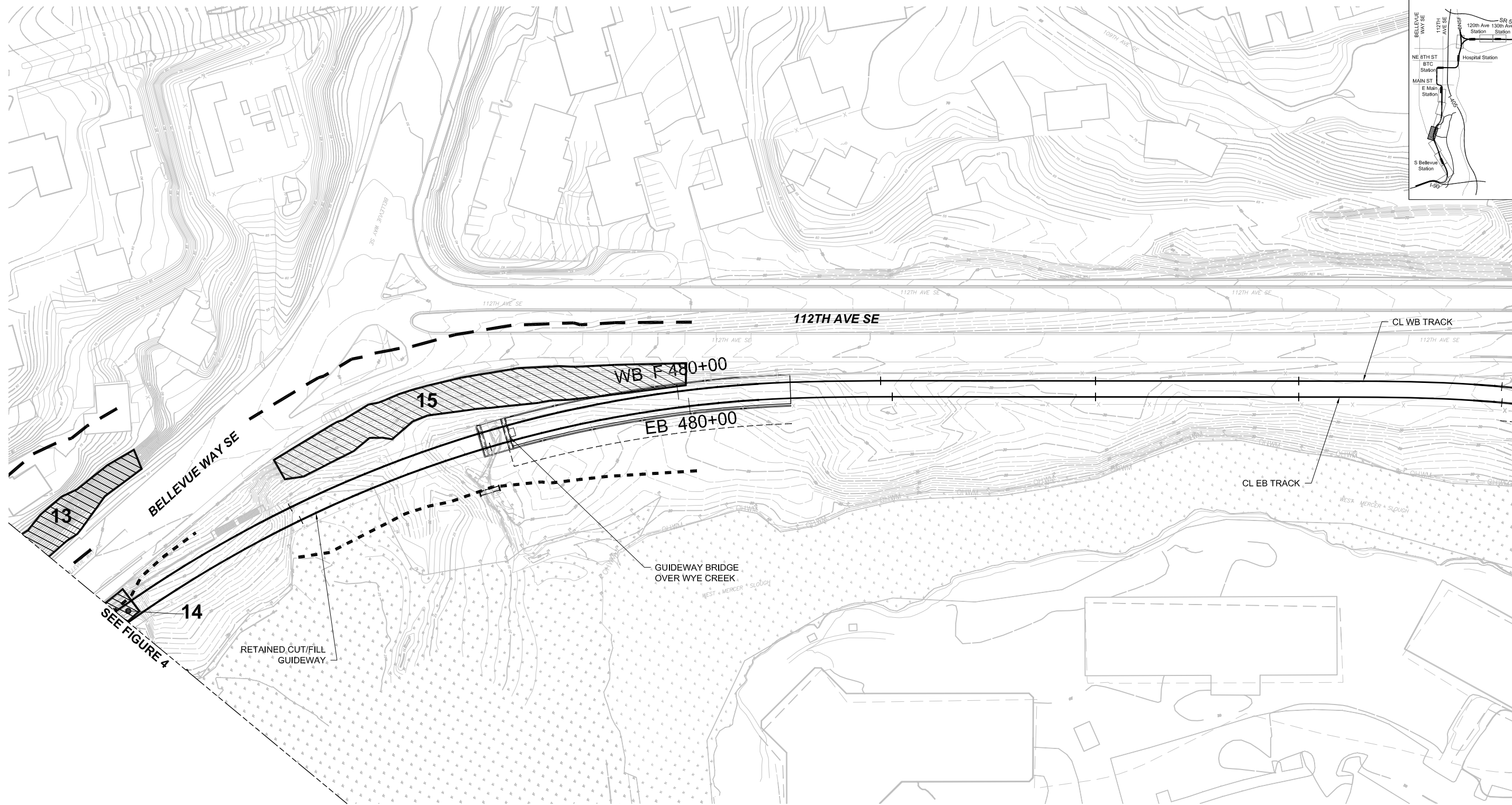

- LEGEND:**
-  STEEP SLOPE
 -  STEEP SLOPE CRITICAL AREA BUFFER
 -  STEEP SLOPE STRUCTURE SETBACK

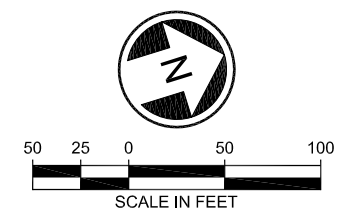



08/27/14 | 2:27 PM | JLOGAN | J:\65229\CADD\SS\01\DRAWINGS\ARCH\CRITICAL AREAS REPORT\GEOHAZARD\320-LB5-CAR101.DWG

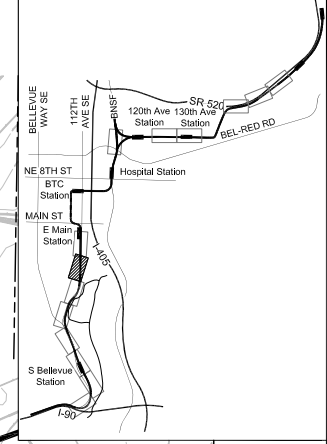
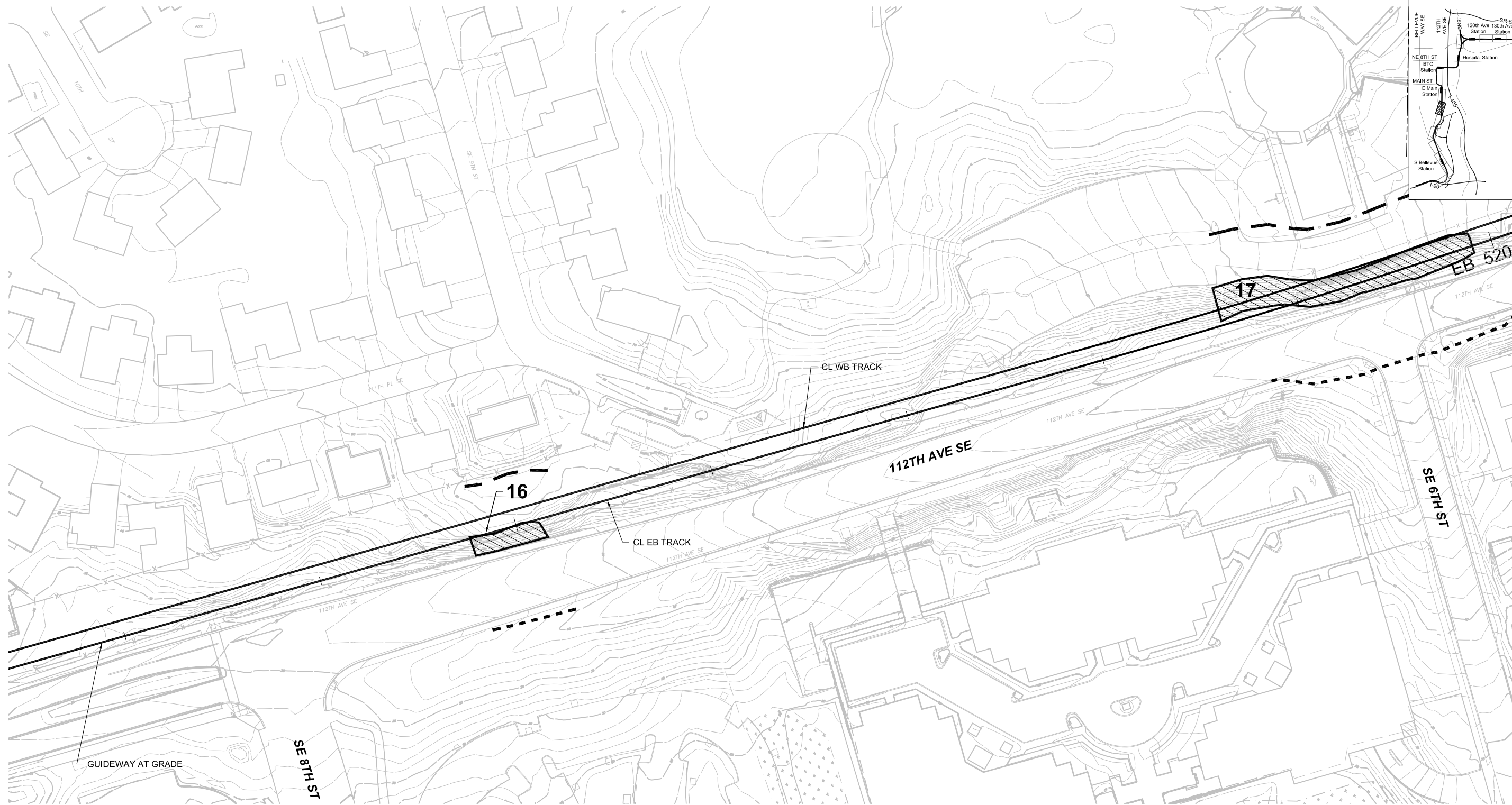

EAST LINK EXTENSION
 SOUTH BELLEVUE TO OVERLAKE TRANSIT CENTER
 APPENDIX E
 FIGURE 5
 GEOLOGIC HAZARD AREAS



LEGEND:

-  STEEP SLOPE
-  STEEP SLOPE CRITICAL AREA BUFFER
-  STEEP SLOPE STRUCTURE SETBACK

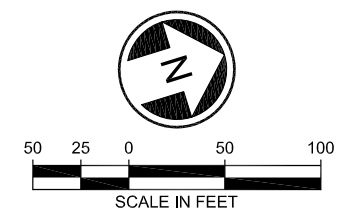

SEE FIGURE 7



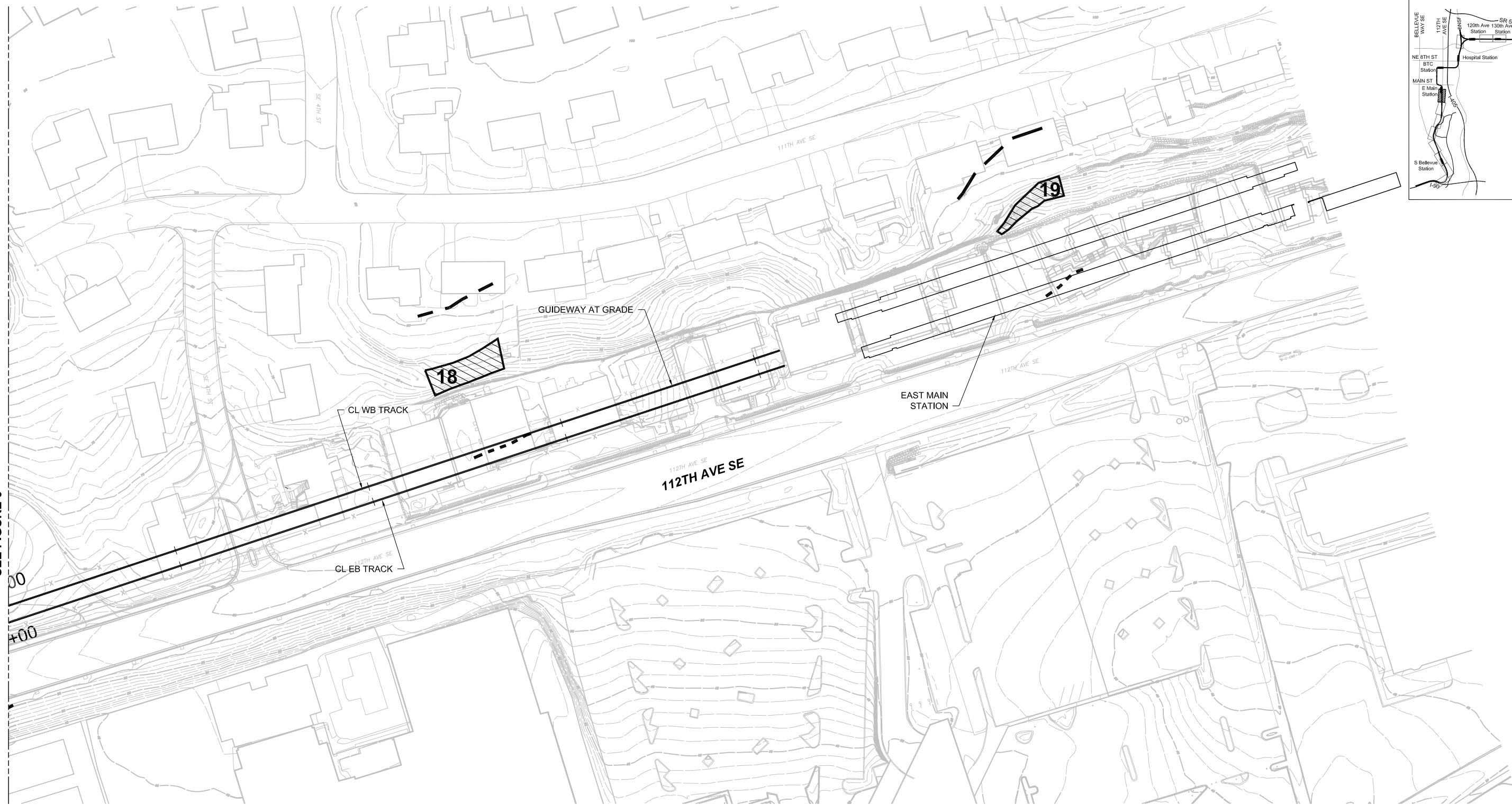
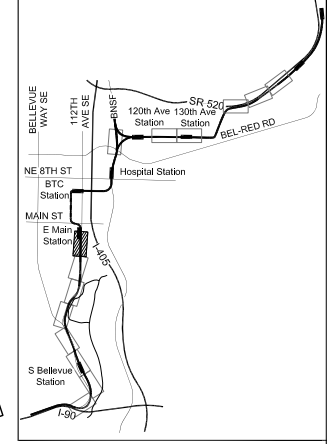

EAST LINK EXTENSION
 SOUTH BELLEVUE TO OVERLAKE TRANSIT CENTER
 APPENDIX E
 FIGURE 6
 GEOLOGIC HAZARD AREAS



SEE FIGURE 6

LEGEND:

-  STEEP SLOPE
-  STEEP SLOPE CRITICAL AREA BUFFER
-  STEEP SLOPE STRUCTURE SETBACK

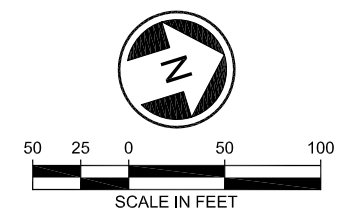

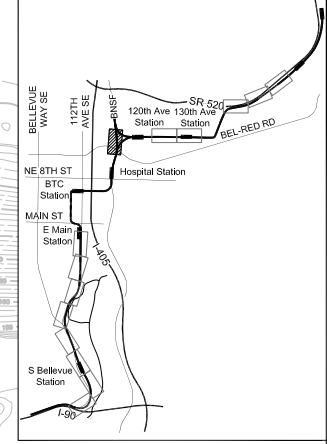
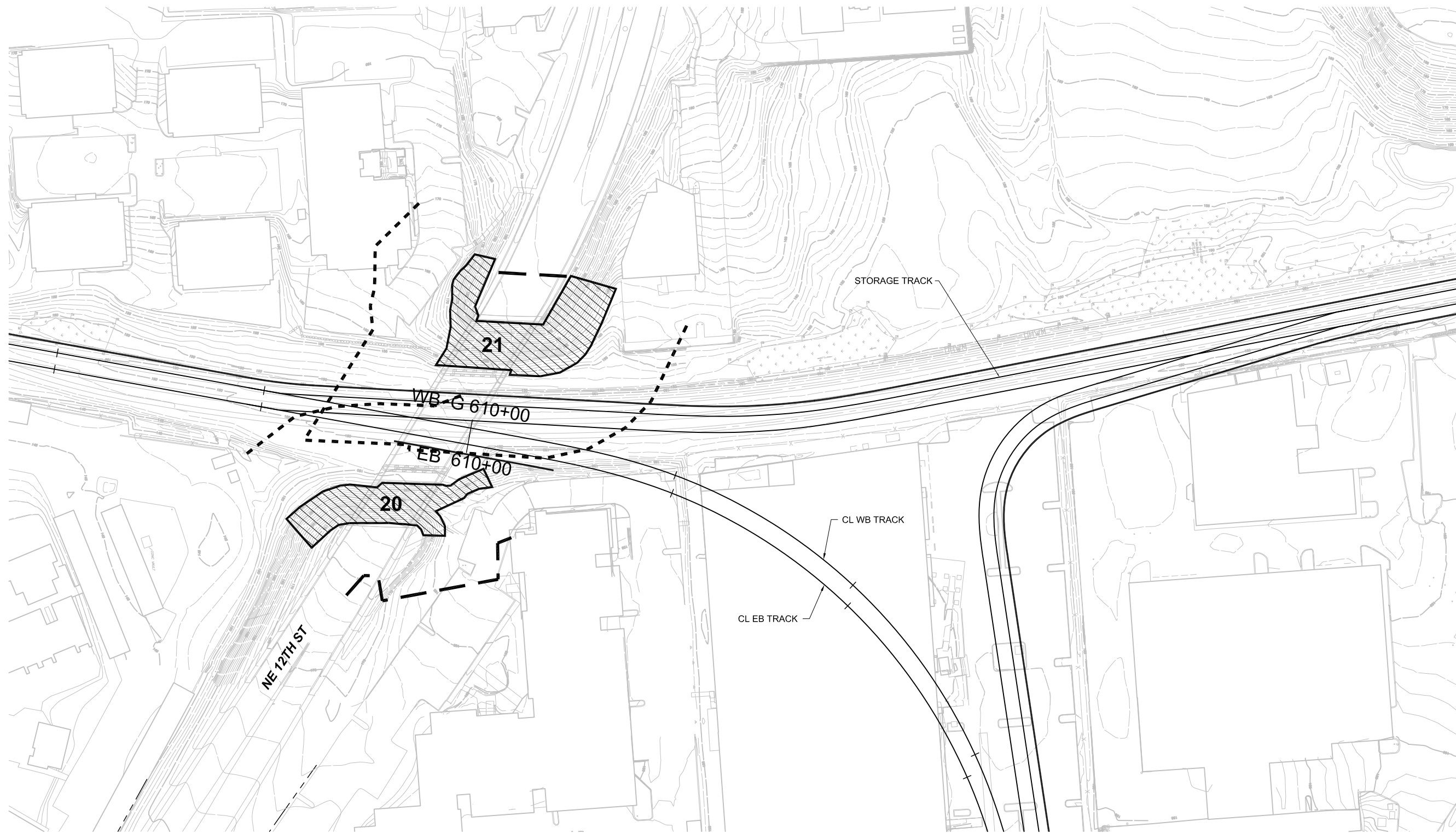

EAST LINK EXTENSION
 SOUTH BELLEVUE TO OVERLAKE TRANSIT CENTER
 APPENDIX E
 FIGURE 7
 GEOLOGIC HAZARD AREAS

08/27/14 | 2:32 PM | JLOGAN | J:\65229\CAD\DD\01\DRAWINGS\ARCH\CRITICAL AREAS REPORT\GEOHAZARD\320-LB-CAR101.DWG

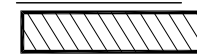

LEGEND:

-  STEEP SLOPE
-  STEEP SLOPE CRITICAL AREA BUFFER
-  STEEP SLOPE STRUCTURE SETBACK

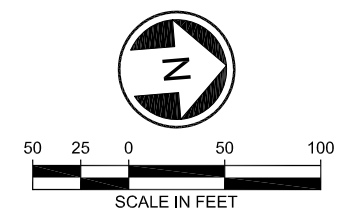

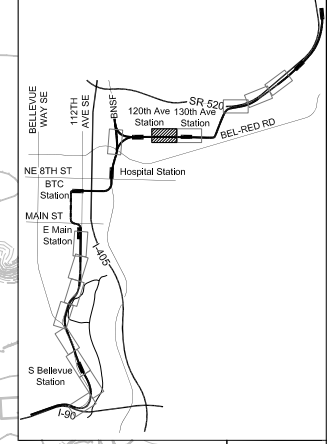
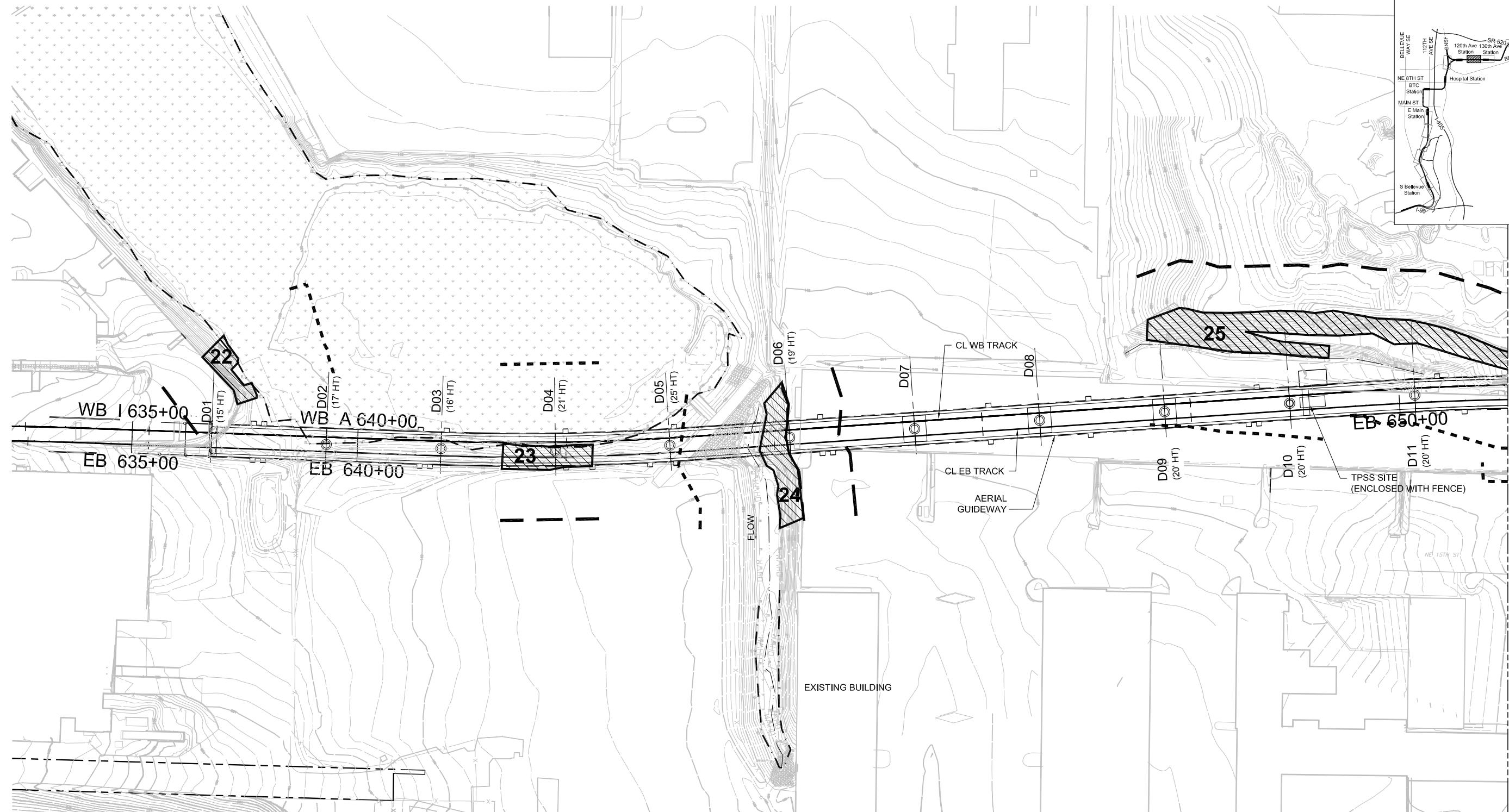

EAST LINK EXTENSION
 SOUTH BELLEVUE TO OVERLAKE TRANSIT CENTER
 APPENDIX E
 FIGURE 8
 GEOLOGIC HAZARD AREAS

08/27/14 | 2:35 PM | JLOGAN
 J:\65229\CADD\SS\01DRAWINGS\ARCH\CRITICAL AREAS REPORT\GEOHAZARD\E-340-LB7-CAR101.DWG

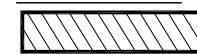

LEGEND:

-  STEEP SLOPE
-  STEEP SLOPE CRITICAL AREA BUFFER
-  STEEP SLOPE STRUCTURE SETBACK

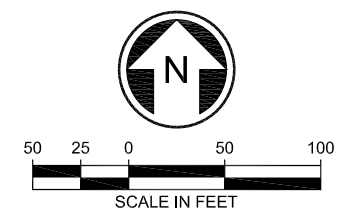

SEE FIGURE 10



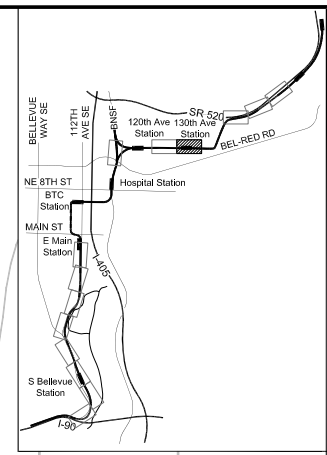
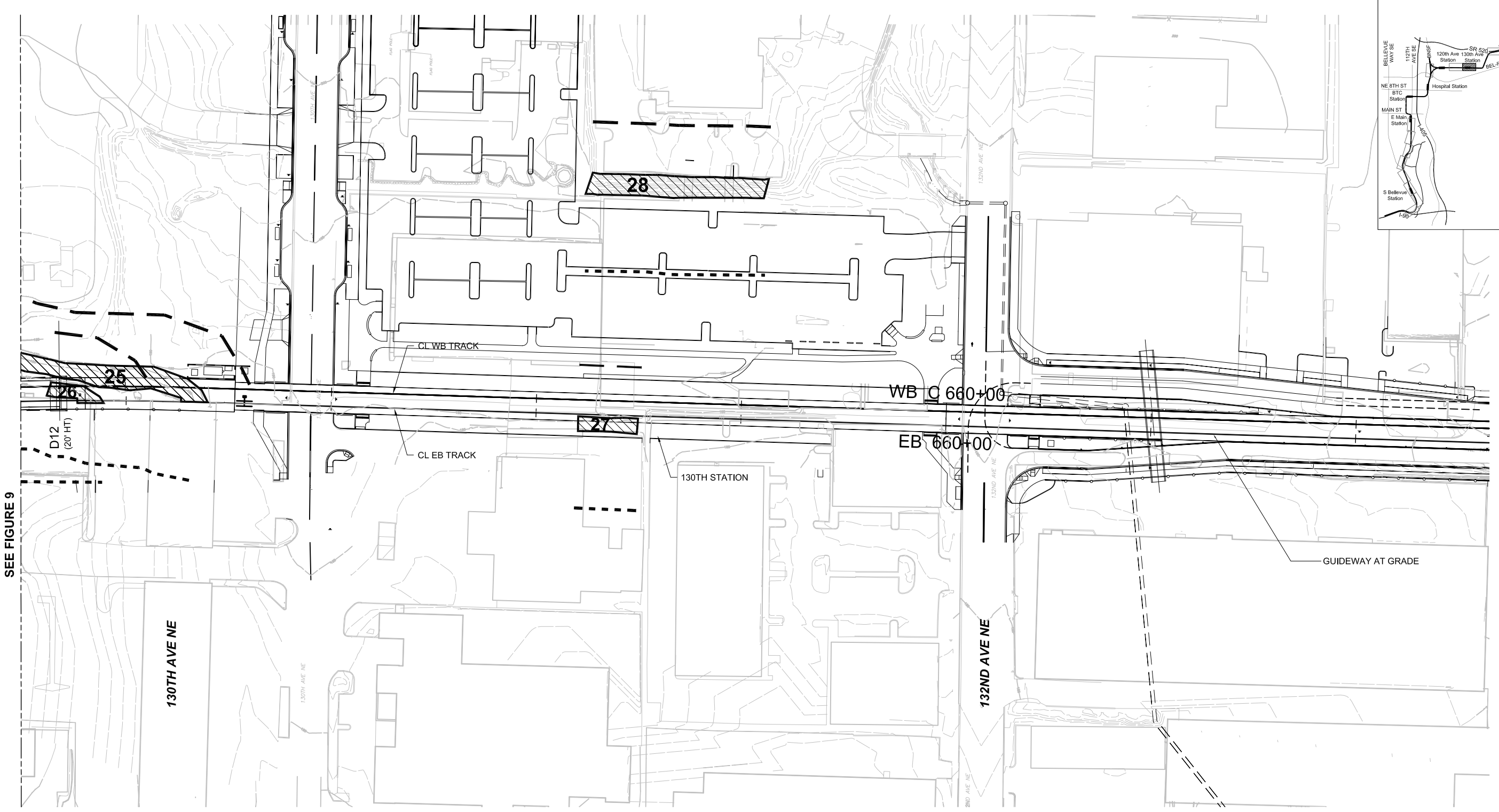

EAST LINK EXTENSION
 SOUTH BELLEVUE TO OVERLAKE TRANSIT CENTER
 APPENDIX E
 FIGURE 9
 GEOLOGIC HAZARD AREAS



SEE FIGURE 9

LEGEND:

-  STEEP SLOPE
-  STEEP SLOPE CRITICAL AREA BUFFER
-  STEEP SLOPE STRUCTURE SETBACK

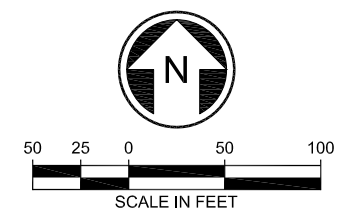

EAST LINK EXTENSION
 SOUTH BELLEVUE TO OVERLAKE TRANSIT CENTER
 APPENDIX E
 FIGURE 10
 GEOLOGIC HAZARD AREAS

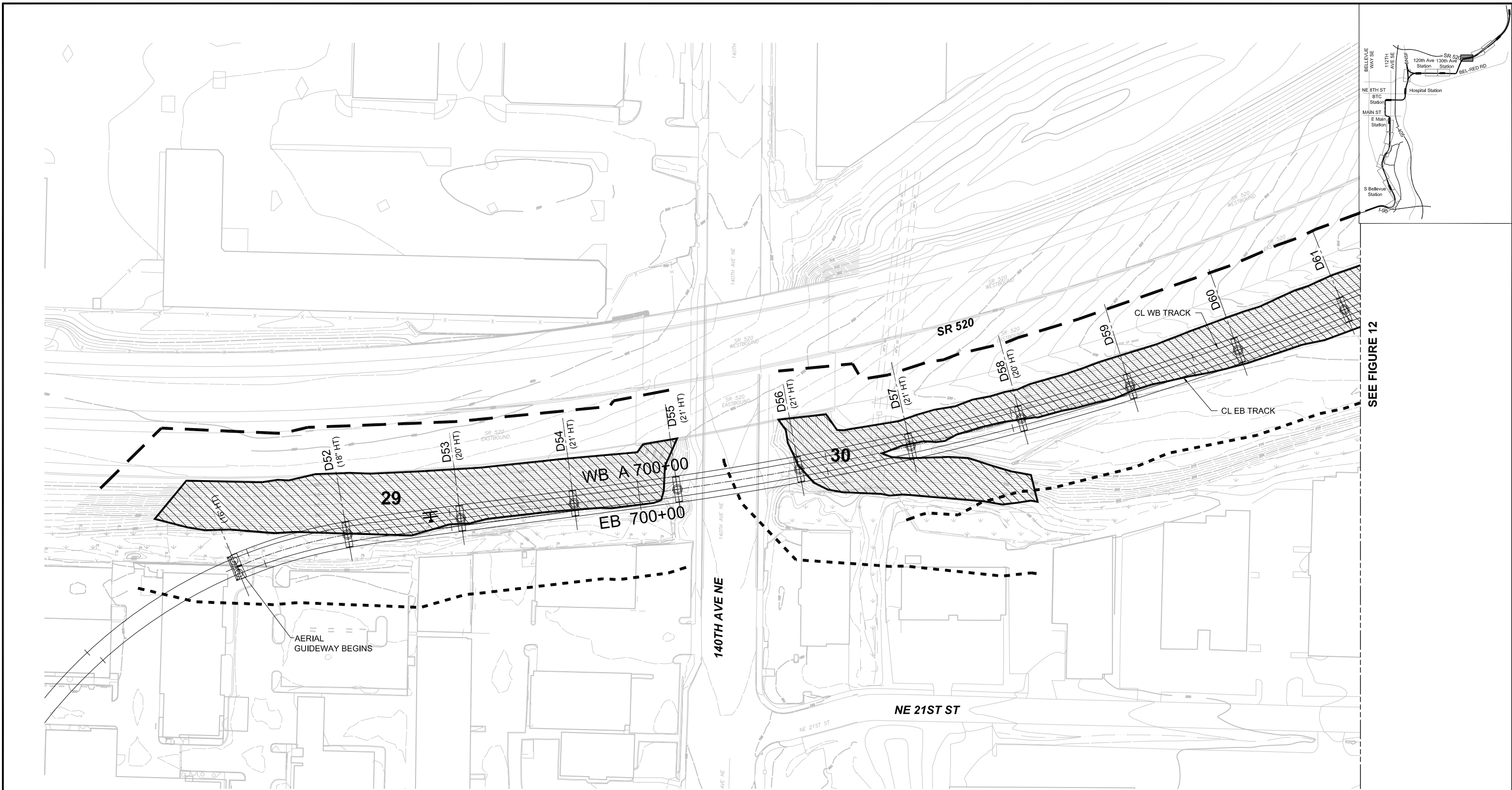

08/27/14 | 2:37 PM | JLOGAN
 J:\65229\CADD\SS\01DRAWINGS\ARCH\CRITICAL AREAS REPORT\GEOHAZARD\E-340-LB7-CAR101.DWG

08/27/14 | 2:38 PM | JLOGAN
J:\65229\CAD\DD\01\DRAWINGS\ARCH\CRITICAL AREAS REPORT\GEOHAZARD\360-L88-CAR101.DWG

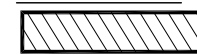

SEE FIGURE 12

LEGEND:

-  STEEP SLOPE
-  STEEP SLOPE CRITICAL AREA BUFFER
-  STEEP SLOPE STRUCTURE SETBACK

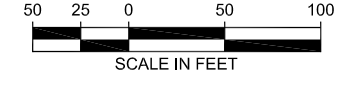

EAST LINK EXTENSION
 SOUTH BELLEVUE TO OVERLAKE TRANSIT CENTER
 APPENDIX E
 FIGURE 11
 GEOLOGIC HAZARD AREAS

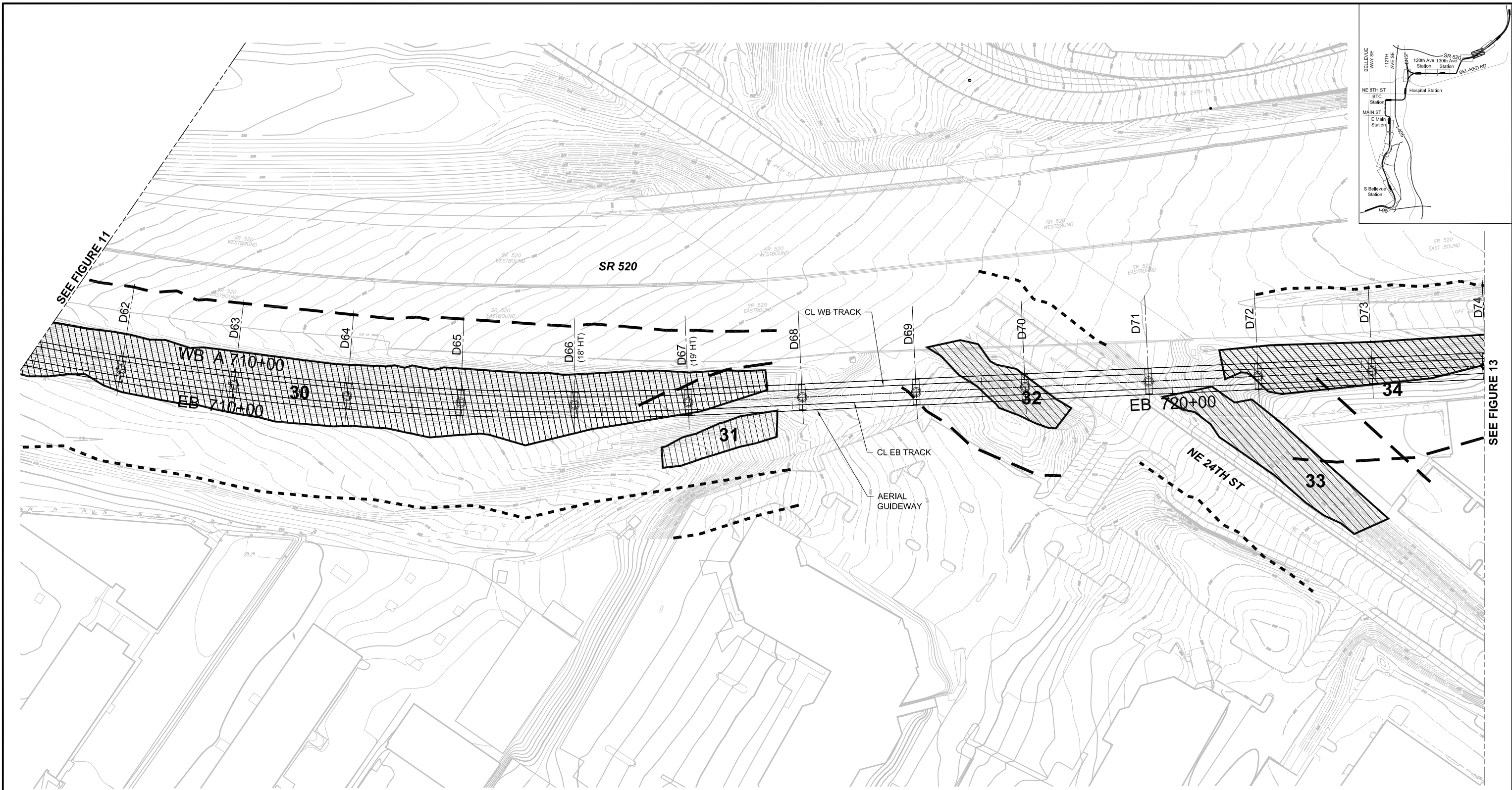
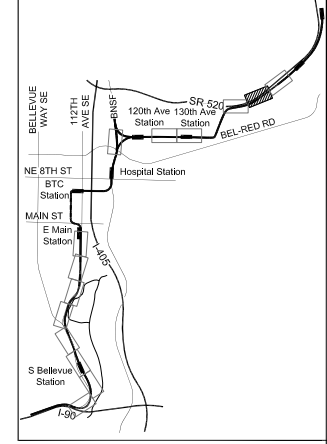

- LEGEND:**
-  STEEP SLOPE
 -  STEEP SLOPE CRITICAL AREA BUFFER
 -  STEEP SLOPE STRUCTURE SETBACK

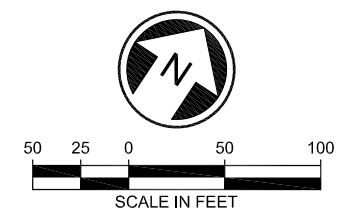

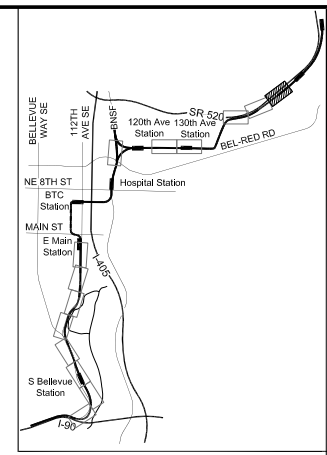
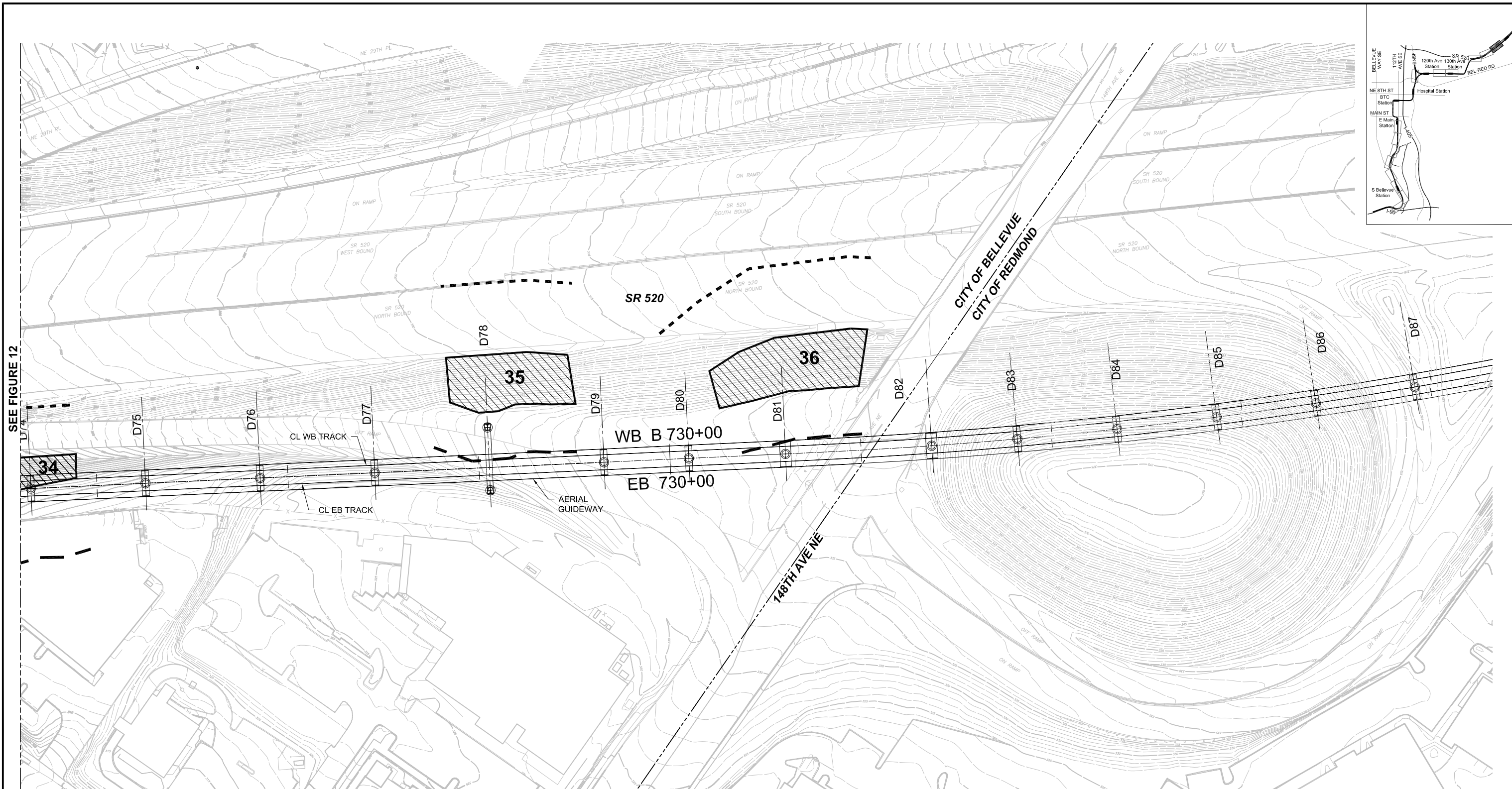

EAST LINK EXTENSION
 SOUTH BELLEVUE TO OVERLAKE TRANSIT CENTER
 APPENDIX E
 FIGURE 12
 GEOLOGIC HAZARD AREAS

08/27/14 | 2:38 PM | JLOGAN | J:\65229\CADD\SS\01\DRAWINGS\ARCH\CRITICAL AREAS REPORT\GEOHAZARD\360-L88-CAR101.DWG



SEE FIGURE 12

LEGEND:

-  STEEP SLOPE
-  STEEP SLOPE CRITICAL AREA BUFFER
-  STEEP SLOPE STRUCTURE SETBACK

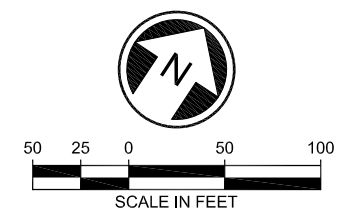

EAST LINK EXTENSION
 SOUTH BELLEVUE TO OVERLAKE TRANSIT CENTER
 APPENDIX E
 FIGURE 13
 GEOLOGIC HAZARD AREAS

08/27/14 | 2:39 PM | JLOGAN
 J:\65229\CADD\SS\01DRAWINGS\ARCH\CRITICAL AREAS REPORT\GEOHAZARD\E-360-L88-CAR101.DWG

Appendix F

Impact and Mitigation Summary by Contract Package

**East Link | South Bellevue to Overlake Transit Center
Contract No. RTA/AE 0143-11**

**East Link Light Rail Extension
Critical Areas Report and Mitigation Plan
Appendix F: Impact and Mitigation Summary
by Contract Package
(for City of Bellevue)**

June 2015

Prepared for:



Prepared by:



FINAL DESIGN PARTNERS.



Contents

1.0	Introduction	F-1
1.1	Species of Local Importance	F-1
1.2	Wetlands	F-1
1.3	Streams	F-2
2.0	E320 Package	F-4
2.1	Species of Local Importance	F-4
2.2	Wetlands	F-6
2.3	Streams	F-8
3.0	E335 Package	F-9
3.1	Species of Local Importance	F-9
3.3	Wetlands	F-11
3.4	Streams	F-13
4.0	E340 Package	F-14
4.1	Species of Local Importance	F-14
4.2	Wetlands	F-16
4.3	Streams	F-18
5.0	E360 Package	F-19
5.1	Species of Local Importance	F-19
5.2	Wetlands	F-21
5.3	Streams	F-23
6.0	Coal Creek Mitigation Site	F-24
6.1	Species of Local Importance	F-24
6.2	Wetlands	F-25
6.3	Streams	F-28
7.0	References	F-29

Tables

Table 2-1	Species of Local Importance Potential Presence within the E320 Package.....	F-4
Table 2-2	Summary of Wetlands Located within the E320 Package	F-6
Table 2-3	Summary of Wetland State and Local Ratings and City of Bellevue Buffer Widths for the E320 Package.....	F-6
Table 2-4	Summary of Wetland Impacts within the E320 Package	F-7
Table 2-5	Summary of Streams Located within the E320 Package.....	F-8
Table 2-6	Local Critical Areas Regulations Stream Rating and Buffer Distance within the E320 Package.....	F-8
Table 2-7	Summary of Stream Impacts within the E320 Package	F-8
Table 3-1	Species of Local Importance Potential Presence within the E335 Package.....	F-9
Table 3-2	Summary of Wetlands Located within the E335 Package	F-11

Table 3-3 Summary of Wetland State and Local Ratings and City of Bellevue Buffer Widths for the E335 Package.....	F-11
Table 3-4 Summary of Wetland Impacts within the E335 Package	F-12
Table 3-5 Summary of Streams Located within the E335 Package.....	F-13
Table 3-6 Local Critical Areas Regulations Stream Rating and Buffer Distance within the E335 Package.....	F-13
Table 3-7 Summary of Stream Impacts within the E335 Package	F-13
Table 4-1 Species of Local Importance Potential Presence within the E340 Package.....	F-14
Table 4-2 Summary of Wetlands Located within the E340 Package	F-16
Table 4-3 Summary of Wetland State and Local Ratings and City of Bellevue Buffer Widths for the E340 Package.....	F-16
Table 4-4 Summary of Wetland Impacts within the E340 Package	F-17
Table 4-5 Summary of Streams Located within the E340 Package.....	F-18
Table 4-6 Local Critical Areas Regulations Stream Rating and Buffer Distance within the E340 Package.....	F-18
Table 4-7 Summary of Stream Impacts within the E340 Package	F-18
Table 5-1 Species of Local Importance Potential Presence within the E360 Package.....	F-19
Table 5-2 Summary of Wetlands Located within the E360 Package	F-21
Table 5-3 Summary of Wetland State and Local Ratings and City of Bellevue Buffer Widths for the E360 Package.....	F-21
Table 5-4 Summary of Wetland Impacts within the E360 Package	F-22
Table 5-5 Summary of Streams Located within the E360 Package.....	F-23
Table 5-6 Local Critical Areas Regulations Stream Rating and Buffer Distance within the E360 Package.....	F-23
Table 6-1 Species of Local Importance Potential Presence within Coal Creek Mitigation Site	F-24
Table 6-2 Summary of Wetlands Located within Coal Creek Mitigation Site	F-25
Table 6-3 Summary of Wetland State and Local Ratings and City of Bellevue Buffer Widths for Coal Creek Mitigation Site	F-26
Table 6-4 Summary of Wetland Impacts within Coal Creek Mitigation Site.....	F-27
Table 6-5 Summary of Streams Located within Coal Creek Mitigation Site	F-28
Table 6-6 Local Critical Areas Regulations Stream Rating and Buffer Distance within Coal Creek Mitigation Site	F-28
Table 6-7 Summary of Stream Impacts within the Coal Creek Mitigation Site	F-28

Figures

Figure F-1 East Link Project Contract Packages	F-3
--	-----

1.0 Introduction

This East Link Light Rail Extension Project (Project) Impacts and Mitigation Summary provides a breakdown of the species of local importance, wetlands, and streams identified in the Critical Areas Report and Mitigation Plan (CAR), associated with the Project Contract Packages within the City of Bellevue (City). The Project has been divided into the following five Contract Packages associated with the geographic location of the Project alignment (Figure 1):

- E320 Package - South Bellevue
- E330 Package - Downtown Bellevue Tunnel
- E335 Package - Downtown Bellevue To Spring District
- E340 Package - Bel-Red
- E360 Package - SR 520

This document provides information on species of local importance, wetlands, and streams within each segment, with the exception of the E330 Package. The entire length of the E330 Package is a tunnel located beneath Downtown Bellevue. This segment is not discussed further in this report because it does not contain any resources. In addition, there are five mitigation sites associated with the Project, and four of the five are located within one of the Contract Packages. The fifth mitigation site, Coal Creek, is located south of the Project and is not associated with a Contract Package segment. Information on species of local importance, wetlands, and streams associated with the Coal Creek mitigation site are discussed following the Contract Package segment sections.

1.1 Species of Local Importance

The City recognizes 23 species of local importance (LUC 20.25H.150; City of Bellevue 2013a). The 23 species of local importance by group (amphibians, birds, mammals, reptiles, and fish), the presence or absence of potential suitable habitat within the Project area, and the state and federal status of each species (LUC 20.25H.150; City of Bellevue 2013a) are provided for each segment and the Coal Creek Mitigation Site in Tables 2-1, 3-1, 4-1, 5-1, and 6-1.

1.2 Wetlands

Twenty-two wetlands were identified within the Project area. A summary of wetlands in the Project area, including the approximate wetland size, drainage basin, U.S. Fish and Wildlife Service (USFWS) classification, and hydrogeomorphic classification, is provided for each segment and the Coal Creek Mitigation Site in Tables 2-2, 3-2, 4-2, 5-2, and 6-2. A summary of state and local wetland ratings and protective buffer widths, per the BCC, is provided for each segment and the Coal Creek Mitigation Site in Tables 2-3, 3-3, 4-3, 5-3, and 6-3. Wetland impacts and wetland buffer impacts, both temporary and permanent, are also provided by segment and the Coal Creek Mitigation Site, including wetland vegetation conversion impacts in Tables 2-4, 3-4, 4-4 5-4, and 6-4.

1.3 Streams

Eleven streams were identified within the Project area. A summary of streams in the Project area, including the delineated ordinary high water mark (OHWM) length and drainage basin is provided for each segment and the Coal Creek Mitigation Site in Tables 2-5, 3-5, 4-5, 5-5, and 6-5. A summary of the streams state and local ratings and protective buffer widths, per the Bellevue City Code (BCC), is provided by Package and the Coal Creek Mitigation Site in Tables 2-6, 3-6, 4-6, 5-6, and 6-6. Stream impacts and stream buffer impacts, both temporary and permanent, are also provided by segment in Tables 2-7, 3-7, and 4-7.

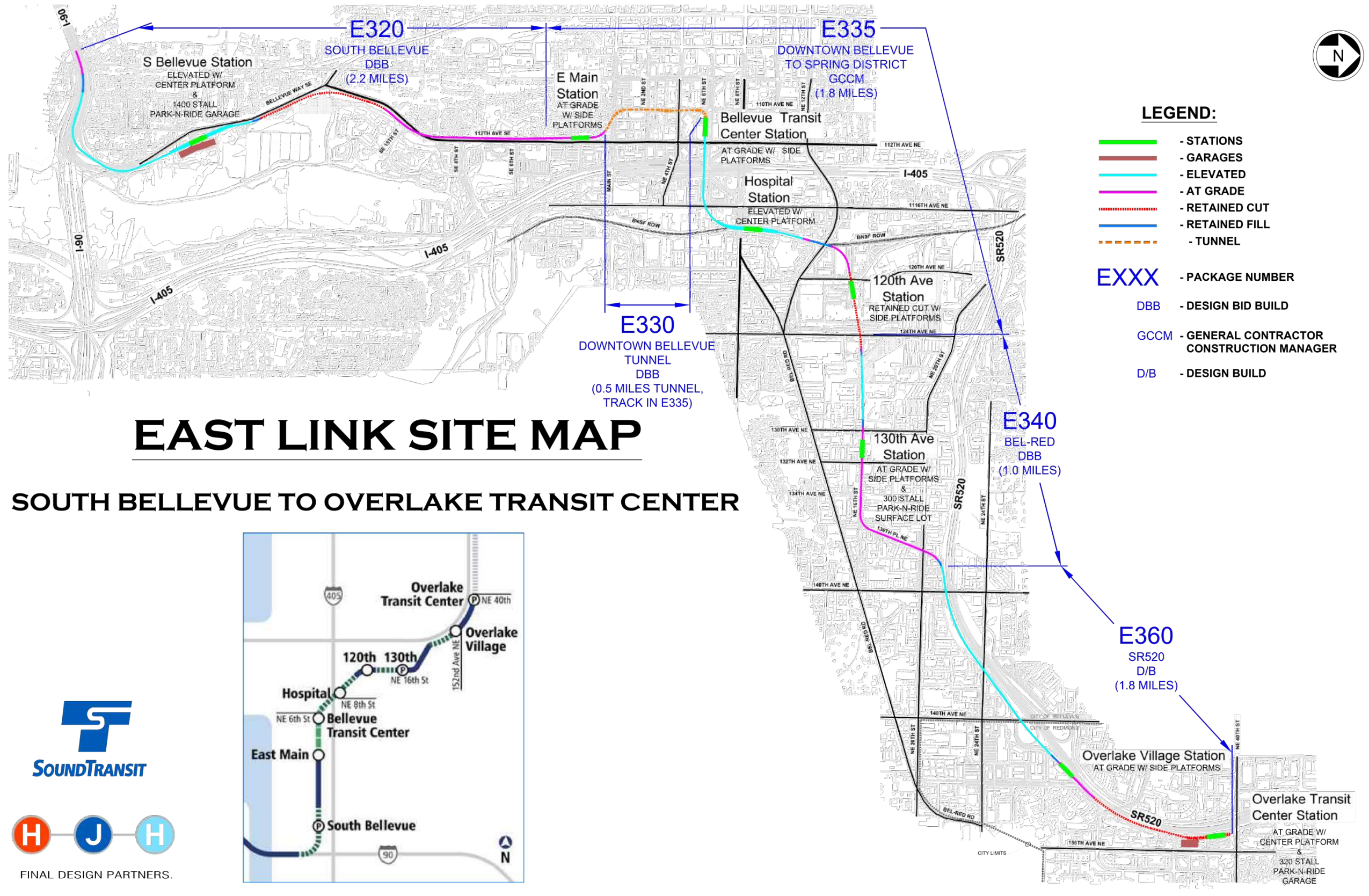

2.0 E320 Package

2.1 Species of Local Importance

Table 2-1 Species of Local Importance Potential Presence within the E320 Package

Common Name (Scientific Name)	Suitable Habitat	Potential Suitable Habitat Present Within Project Area	State Status	Federal Status
Amphibians				
Oregon spotted frog (<i>Rana pretiosa</i>)	Ponds and lakes with dense emergent vegetation	Yes (Mercer Slough habitat)	Endangered	Threatened
Western toad (<i>Bufo boreas</i>)	Still water in ponds and small lakes	Yes (Mercer Slough habitat)	Candidate	Species of concern
Birds				
Bald eagle (<i>Haliaeetus leucocephalus</i>)	Mature trees near water and prey sources	Yes (Mercer Slough habitat)	Sensitive	Species of concern
Common loon (<i>Gavia immer</i>)	Marine and large lakes and rivers	No (Lake Washington outside Project area)	Sensitive	None
Great blue heron (<i>Ardea herodias</i>)	Fresh and salt-water wetlands, rivers	Yes (Mercer Slough)	Priority	Monitor
Green heron (<i>Butorides striatus</i>)	Fresh water wetlands with forested habitat	Yes (Mercer Slough)	None	None
Merlin (<i>Falco columbarius</i>)	Prairies and conifer forests	No	Candidate	None
Osprey (<i>Pandion haliaetus</i>)	Marine coasts, lakes, and rivers	Yes (Mercer Slough)	None	None
Peregrine falcon (<i>Falco peregrinus</i>)	Cliffs and vegetated slopes	No	Sensitive	Species of concern
Pileated woodpecker (<i>Dryocopus pileatus</i>)	Forest with snags and downed wood	Yes (Mercer Slough and mature trees)	Candidate	None
Purple martin (<i>Progne subis</i>)	Large dead trees or artificial nesting structures near wetlands, ponds, or marine systems	Yes (Mercer Slough and mature trees)	Candidate	None
Red-tailed hawk (<i>Buteo jamaicensis</i>)	Open habitat near forests	Yes (Mercer Slough and mature trees)	None	None
Vaux's swift (<i>Chaetura vauxi</i>)	Old growth forest	No	Candidate	None
Western Grebe (<i>Aechmophorus occidentalis</i>)	Large lakes	No (Lake Washington outside Project area)	Candidate	None

Common Name (Scientific Name)	Suitable Habitat	Potential Suitable Habitat Present Within Project Area	State Status	Federal Status
Fish/Salmon				
Bull trout (<i>Salvelinus confluentus</i>)	Marine, rivers, and streams	Yes (Mercer Slough)	Candidate	Threatened
Chinook salmon (<i>Oncorhynchus tshawytscha</i>)	Marine, rivers, and streams	Yes (Mercer Slough)	Candidate	Threatened
Coho salmon (<i>Oncorhynchus kisutch</i>)	Marine, rivers, and streams	Yes (Mercer Slough)	Candidate	Species of concern
River lamprey (<i>Lampetra ayresi</i>)	Rivers and streams	Yes (Mercer Slough)	None	Species of concern
Mammals				
Keen's myotis (<i>Myotis keenii</i>)	Mature coniferous forest	Yes (Mercer Slough habitat and mature trees)	Candidate	None
Long-eared myotis (<i>Myotis evotis</i>)	Mature coniferous forest	Yes (Mercer Slough habitat and mature trees)	Monitored	None
Long-legged myotis (<i>Myotis volans</i>)	Mature coniferous forest	Yes (Mercer Slough habitat and mature trees)	Monitored	None
Western big-eared bat (<i>Plecotus townsendii</i>)	Mature coniferous forest	Yes (Mercer Slough habitat and mature trees)	None	None
Reptiles				
Western pond turtle (<i>Clemmys marmorata</i>)	Ponds, sloughs, small lakes	Yes (Mercer Slough habitat)	Endangered	Species of concern

Note:

Sources: City of Bellevue 2013, WDFW 2013, Larsen 1997, and Larsen et al. 2004.

2.2 Wetlands

Table 2-2 Summary of Wetlands Located within the E320 Package

Wetland Name	Size (acres)	Drainage Basin	USFWS Classification	Hydrogeomorphic Classification Used for Rating
Mercer Slough	350 ^a	Mercer Slough	PFO, PSS, PEM, PAB	Depressional, Lake-Fringe, Riverine, Slope
Alcove Creek	0.64 ^a	Mercer Slough	PFO, PSS, PEM	Depressional, Riverine
Bellefield South	0.29	Mercer Slough	PFO, PSS, PEM	Riverine, Slope
Bellefield North	0.11	Mercer Slough	PFO, PSS	Riverine, Slope
8th Street	0.13 ^a	Mercer Slough	PFO, PSS, PEM	Depressional

Notes:

- a Approximate total wetland area, includes delineated area plus estimated wetland area extending outside Project area.
- PFO = palustrine forested
- PSS = palustrine scrub-shrub
- PEM = palustrine emergent
- PAB = palustrine aquatic bed
- USFWS = U.S. Fish and Wildlife Service

Table 2-3 Summary of Wetland State and Local Ratings and City of Bellevue Buffer Widths for the E320 Package

Wetland Name	State (Ecology) and Local (Bellevue) Rating	Bellevue Buffer Widths (feet)
Mercer Slough	II	110
Alcove Creek	II	75
Bellefield South	II	75
Bellefield North	II	75
8th Street	III	60

Note:

Ecology = Washington State Department of Ecology

Table 2-4 Summary of Wetland Impacts within the E320 Package

Site	Drainage Sub-basin	Permanent Impact (acres)	Permanent Vegetation Conversion (acres)	Temporary Impact (acres)	Permanent Buffer Impact (acres)	Temporary Buffer Impact (acres)
Mercer Slough	Mercer Slough	0.17 ^a	0.32	0.22	4.10	4.43
Alcove Creek	Mercer Slough	0.00	0.00	0.01	0.09	0.08
Bellefield South	Mercer Slough	0.05	0.00	0.04	0.20	0.01
Bellefield North	Mercer Slough	0.01	0.00	0.02	0.24	0.04
8th Street	Mercer Slough	0.13	0.00	0.00	0.00	0.00
Total Wetland Impacts:		0.43	0.32	0.29	4.63	4.56

Note:

a This includes .02 acre of impact from pin piles, which is not regulated by the U.S. Army Corps of Engineers.

2.3 Streams

Table 2-5 Summary of Streams Located within the E320 Package

Stream	OHWL Length ¹ (feet)	Drainage Basin ²
Stream A	260	Mercer Slough
Stream B	83	Mercer Slough
Wye Creek	150	Mercer Slough
Alcove Creek	226	Mercer Slough

Notes:

1 Calculations provided by HJH for open channel areas that were delineated.

2 City of Bellevue 2013b.

OHWL = ordinary high water mark

Table 2-6 Local Critical Areas Regulations Stream Rating and Buffer Distance within the E320 Package

Stream	Local Stream Rating ¹	Buffer Width (feet)
Stream A	Type N	50
Stream B	Type N	50
Wye Creek	Type F	100
Mercer Slough	Type S	100
Alcove Creek	Type F	100

Note:

1 BCC (City of Bellevue 2013a).

Table 2-7 Summary of Stream Impacts within the E320 Package

Stream	Local Stream Rating	Permanent Impacts (sf)	Temporary Impacts (sf)	Permanent Buffer Impacts ¹ (acres)	Temporary Buffer Impacts (acres)
Wye Creek	Type F	420	110	0.09	0.11
Alcove Creek	Type F	236	33	0.00	0.00
Total Stream Impacts:		656	143	0.09	0.11

Notes:

1 Areas only include stream buffer where there is no wetland buffer overlap. Overlapping buffer areas are counted as wetland buffers and included in Table 2-4.

sf = square feet

3.0 E335 Package

3.1 Species of Local Importance

Table 3-1 Species of Local Importance Potential Presence within the E335 Package

Common Name (Scientific Name)	Suitable Habitat	Potential Suitable Habitat Present Within Project Area	State Status	Federal Status
Amphibians				
Oregon spotted frog (<i>Rana pretiosa</i>)	Ponds and lakes with dense emergent vegetation	No	Endangered	Threatened
Western toad (<i>Bufo boreas</i>)	Still water in ponds and small lakes	No	Candidate	Species of concern
Birds				
Bald eagle (<i>Haliaeetus leucocephalus</i>)	Mature trees near water and prey sources	No	Sensitive	Species of concern
Common loon (<i>Gavia immer</i>)	Marine and large lakes and rivers	No	Sensitive	None
Great blue heron (<i>Ardea herodias</i>)	Fresh and salt-water wetlands, rivers	No	Priority	Monitor
Green heron (<i>Butorides striatus</i>)	Fresh water wetlands with forested habitat	No	None	None
Merlin (<i>Falco columbarius</i>)	Prairies and conifer forests	No	Candidate	None
Osprey (<i>Pandion haliaetus</i>)	Marine coasts, lakes, and rivers	No	None	None
Peregrine falcon (<i>Falco peregrinus</i>)	Cliffs and vegetated slopes	No	Sensitive	Species of concern
Pileated woodpecker (<i>Dryocopus pileatus</i>)	Forest with snags and downed wood	Yes (mature trees)	Candidate	None
Purple martin (<i>Progne subis</i>)	Large dead trees or artificial nesting structures near wetlands, ponds, or marine systems	Yes (mature trees)	Candidate	None
Red-tailed hawk (<i>Buteo jamaicensis</i>)	Open habitat near forests	Yes (mature trees)	None	None
Vaux's swift (<i>Chaetura vauxi</i>)	Old growth forest	No	Candidate	None
Western Grebe (<i>Aechmophorus occidentalis</i>)	Large lakes	No	Candidate	None

Common Name (Scientific Name)	Suitable Habitat	Potential Suitable Habitat Present Within Project Area	State Status	Federal Status
Fish/Salmon				
Bull trout (<i>Salvelinus confluentus</i>)	Marine, rivers, and streams	No	Candidate	Threatened
Chinook salmon (<i>Oncorhynchus tshawytscha</i>)	Marine, rivers, and streams	No	Candidate	Threatened
Coho salmon (<i>Oncorhynchus kisutch</i>)	Marine, rivers, and streams	No	Candidate	Species of concern
River lamprey (<i>Lampetra ayresi</i>)	Rivers and streams	No	None	Species of concern
Mammals				
Keen's myotis (<i>Myotis keenii</i>)	Mature coniferous forest	Yes (mature trees)	Candidate	None
Long-eared myotis (<i>Myotis evotis</i>)	Mature coniferous forest	Yes (mature trees)	Monitored	None
Long-legged myotis (<i>Myotis volans</i>)	Mature coniferous forest	Yes (mature trees)	Monitored	None
Western big-eared bat (<i>Plecotus townsendii</i>)	Mature coniferous forest	Yes (mature trees)	None	None
Reptiles				
Western pond turtle (<i>Clemmys marmorata</i>)	Ponds, sloughs, small lakes	Yes (mature trees)	Endangered	Species of concern

Note:

Sources: City of Bellevue 2013, WDFW 2013, Larsen 1997, and Larsen et al. 2004.

3.3 Wetlands

Table 3-2 Summary of Wetlands Located within the E335 Package

Wetland Name	Size (acres)	Drainage Basin	USFWS Classification	Hydrogeomorphic Classification Used for Rating
Lake Bellevue	7.00 ^a	Sturtevant Creek	PAB	Depressional
South Lake	0.09	Sturtevant Creek	PFO, PSS, PEM	Depressional
Central Lake	0.03	Sturtevant Creek	PSS, PEM	Depressional
North Lake	0.04	Sturtevant Creek	PFO, PEM	Slope
BNSF Southwest	0.12	West Tributary	PFO, PEM	Depressional, Slope
BNSF East	0.12 ^a	West Tributary	PEM	Depressional
BNSF West	0.83 ^a	West Tributary	PFO, PSS, PEM	Depressional, Slope
BNSF Northeast	0.02	West Tributary	PFO, PSS	Depressional
BNSF Northwest	0.06	West Tributary	PFO, PEM	Depressional, Slope
BNSF North	0.02	West Tributary	PFO, PSS	Depressional, Slope

Notes:

a Approximate total wetland area, includes delineated area plus estimated wetland area extending outside Project area.

PFO = palustrine forested

PSS = palustrine scrub-shrub

PEM = palustrine emergent

PAB = palustrine aquatic bed

USFWS = U.S. Fish and Wildlife Service

Table 3-3 Summary of Wetland State and Local Ratings and City of Bellevue Buffer Widths for the E335 Package

Wetland Name	State (Ecology) and Local (Bellevue) Rating	Bellevue Buffer Widths (feet)
Lake Bellevue	III	60
South Lake	III	60
Central Lake	III	60
North Lake	IV	0
BNSF Southwest	III	60
BNSF East	III	60
BNSF West	III	60
BNSF Northeast	III	60
BNSF Northwest	IV	40
BNSF North	III	60

Note:

Ecology = Washington State Department of Ecology

1 **Table 3-4 Summary of Wetland Impacts within the E335 Package**

Site	Drainage Sub-basin	Permanent Impact (acres)	Permanent Vegetation Conversion (acres)	Temporary Impact (acres)	Permanent Buffer Impact (acres)	Temporary Buffer Impact (acres)
South Lake	Sturtevant Creek	0.00	0.09	0.00	0.01	0.27
Central Lake	Sturtevant Creek	0.00	0.03	0.00	0.05	0.09
North Lake	Sturtevant Creek	0.00	0.00	0.04	0.00	0.00
BNSF West	West Tributary	0.00	0.00	0.00	0.09	0.00
BNSF East	West Tributary	0.05	0.08	0.00	0.14	0.01
BNSF Northeast	West Tributary	0.00	0.00	0.00	0.04	0.00
Total Wetland Impacts:		0.05	0.20	0.04	0.33	0.37

2

3.4 Streams

Table 3-5 Summary of Streams Located within the E335 Package

Stream	OHWL Length ¹ (feet)	Drainage Basin ²
Sturtevant Creek	689	Sturtevant Creek

Notes:

1 Calculations provided by HJH for open channel areas that were delineated.

2 City of Bellevue 2013b.

OHWL = ordinary high water mark

Table 3-6 Local Critical Areas Regulations Stream Rating and Buffer Distance within the E335 Package

Stream	Local Stream Rating ¹	Buffer Width (feet)
Sturtevant Creek	Type F	50 ²

Notes:

1 BCC (City of Bellevue 2013a).

2 This stream's buffers were applied based on guidance from City of Bellevue 2013a, Chapter 20.25H.075.C.1.a.

Table 3-7 Summary of Stream Impacts within the E335 Package

Stream	Local Stream Rating	Permanent Impacts (sf)	Temporary Impacts (sf)	Permanent Buffer Impacts ¹ (acres)	Temporary Buffer Impacts (acres)
Sturtevant Creek	Type F	3,443	382	0.21	0.37
Total Stream Impacts:		3,443	382	0.21	0.37

Notes:

1 Areas only include stream buffer where there is no wetland buffer overlap. Overlapping buffer areas are counted as wetland buffers and included in Table 3-4.

sf = square feet

4.0 E340 Package

4.1 Species of Local Importance

Table 4-1 Species of Local Importance Potential Presence within the E340 Package

Common Name (Scientific Name)	Suitable Habitat	Potential Suitable Habitat Present Within Project Area	State Status	Federal Status
Amphibians				
Oregon spotted frog (<i>Rana pretiosa</i>)	Ponds and lakes with dense emergent vegetation	No	Endangered	Threatened
Western toad (<i>Bufo boreas</i>)	Still water in ponds and small lakes	No	Candidate	Species of concern
Birds				
Bald eagle (<i>Haliaeetus leucocephalus</i>)	Mature trees near water and prey sources	No	Sensitive	Species of concern
Common loon (<i>Gavia immer</i>)	Marine and large lakes and rivers	No	Sensitive	None
Great blue heron (<i>Ardea herodias</i>)	Fresh and salt-water wetlands, rivers	Yes (Kelsey West Tributary Pond Wetland habitat)	Priority	Monitor
Green heron (<i>Butorides striatus</i>)	Fresh water wetlands with forested habitat	Yes (Kelsey West Tributary Pond Wetland habitat)	None	None
Merlin (<i>Falco columbarius</i>)	Prairies and conifer forests	No	Candidate	None
Osprey (<i>Pandion haliaetus</i>)	Marine coasts, lakes, and rivers	Yes (Kelsey West Tributary Pond Wetland habitat)	None	None
Peregrine falcon (<i>Falco peregrinus</i>)	Cliffs and vegetated slopes	No	Sensitive	Species of concern
Pileated woodpecker (<i>Dryocopus pileatus</i>)	Forest with snags and downed wood	Yes (Kelsey West Tributary Pond Wetland habitat and mature trees)	Candidate	None
Purple martin (<i>Progne subis</i>)	Large dead trees or artificial nesting structures near wetlands, ponds, or marine systems	Yes (Kelsey West Tributary Pond Wetland habitat and mature trees)	Candidate	None
Red-tailed hawk (<i>Buteo jamaicensis</i>)	Open habitat near forests	Yes (Kelsey West Tributary Pond Wetland habitat and mature trees)	None	None

Common Name (Scientific Name)	Suitable Habitat	Potential Suitable Habitat Present Within Project Area	State Status	Federal Status
Vaux's swift (<i>Chaetura vauxi</i>)	Old growth forest	No	Candidate	None
Western Grebe (<i>Aechmophorus occidentalis</i>)	Large lakes	No	Candidate	None
Fish/Salmon				
Bull trout (<i>Salvelinus confluentus</i>)	Marine, rivers, and streams	No	Candidate	Threatened
Chinook salmon (<i>Oncorhynchus tshawytscha</i>)	Marine, rivers, and streams	No	Candidate	Threatened
Coho salmon (<i>Oncorhynchus kisutch</i>)	Marine, rivers, and streams	No	Candidate	Species of concern
River lamprey (<i>Lampetra ayresi</i>)	Rivers and streams	No	None	Species of concern
Mammals				
Keen's myotis (<i>Myotis keenii</i>)	Mature coniferous forest	Yes (mature trees)	Candidate	None
Long-eared myotis (<i>Myotis evotis</i>)	Mature coniferous forest	Yes (mature trees)	Monitored	None
Long-legged myotis (<i>Myotis volans</i>)	Mature coniferous forest	Yes (mature trees)	Monitored	None
Western big-eared bat (<i>Plecotus townsendii</i>)	Mature coniferous forest	Yes (mature trees)	None	None
Reptiles				
Western pond turtle (<i>Clemmys marmorata</i>)	Ponds, sloughs, small lakes	No	Endangered	Species of concern

Note:

Sources: City of Bellevue 2013, WDFW 2013, Larsen 1997, and Larsen et al. 2004.

4.2 Wetlands

Table 4-2 Summary of Wetlands Located within the E340 Package

Wetland Name	Size (acres)	Drainage Basin	USFWS Classification	Hydrogeomorphic Classification Used for Rating
Kelsey West Tributary Pond	5.98 ^a	West Tributary	PFO, PEM	Depressional, Riverine
Kelsey West Tributary Stream	0.04	West Tributary	PFO, PSS, PEM	Riverine
136th Place	0.03	Kelsey Creek	PFO, PSS, PEM	Depressional

Notes:

a Wetland area is approximate; wetland extends beyond the Project boundary.

PFO = palustrine forested

PSS = palustrine scrub-shrub

PEM = palustrine emergent

PAB = palustrine aquatic bed

USFWS = U.S. Fish and Wildlife Service

Table 4-3 Summary of Wetland State and Local Ratings and City of Bellevue Buffer Widths for the E340 Package

Wetland Name	State (Ecology) and Local (Bellevue) Rating	Bellevue Buffer Widths (feet)
Kelsey West Tributary Pond	II	75
Kelsey West Tributary Stream	III	60
136th Place	III	60

Note:

Ecology = Washington State Department of Ecology

Table 4-4 Summary of Wetland Impacts within the E340 Package

Site	Drainage Sub-basin	Permanent Impact (acres)	Permanent Vegetation Conversion (acres)	Temporary Impact (acres)	Permanent Buffer Impact (acres)	Temporary Buffer Impact (acres)
Kelsey West Tributary Pond	West Tributary	0.01	0.00	0.05	0.13	0.36
Total Wetland Impacts:		0.01	0.00	0.05	0.13	0.36

4.3 Streams

Table 4-5 Summary of Streams Located within the E340 Package

Stream	OHWL Length ¹ (feet)	Drainage Basin ²
West Tributary to Kelsey Creek	321	West Tributary
Stream C	291	West Tributary
Goff Creek	61	Goff Creek
Unnamed Tributary to Kelsey Creek	342	Kelsey Creek

Notes:

- 1 Calculations provided by HJH for open channel areas that were delineated.
 - 2 City of Bellevue 2013b.
- OHWL = ordinary high water mark

Table 4-6 Local Critical Areas Regulations Stream Rating and Buffer Distance within the E340 Package

Stream	Local Stream Rating ¹	Buffer Width (feet)
West Tributary to Kelsey Creek	Type F	50 ²
Stream C	Type O	25
Goff Creek	Type F	50 ³
Unnamed Tributary to Kelsey Creek	Type N	50

Notes:

- 1 BCC (City of Bellevue 2013a).
- 2 Open stream segments, regardless of type, of the West Tributary of Kelsey Creek on developed and undeveloped sites shall have a stream critical area buffer of 50 feet, measured from the top-of-bank. (City of Bellevue 2013a, Chapter 20.25H.075.C.1.c.)
- 3 Buffer is measured from Top of Bank.

Table 4-7 Summary of Stream Impacts within the E340 Package

Stream	Local Stream Rating	Permanent Impacts (sf)	Temporary Impacts (sf)	Permanent Buffer Impacts ¹ (acres)	Temporary Buffer Impacts (acres)
West Tributary to Kelsey Creek	Type F	0	3,814	0.02	0.12
Stream C	Type O	0	1,560	0.07	0.08
Goff Creek	Type F	0	0	0.03	0.00
Unnamed Tributary to Kelsey Creek	Type N	2,887	139	0.09	0.00
Total Stream Impacts:		2,887	5,513	0.21	0.20

Notes:

- 1 Areas only include stream buffer where there is no wetland buffer overlap. Overlapping buffer areas are counted as wetland buffers and included in Table 4-4.
- sf = square feet

5.0 E360 Package

5.1 Species of Local Importance

Table 5-1 Species of Local Importance Potential Presence within the E360 Package

Common Name (Scientific Name)	Suitable Habitat	Potential Suitable Habitat Present Within Project Area	State Status	Federal Status
Amphibians				
Oregon spotted frog (<i>Rana pretiosa</i>)	Ponds and lakes with dense emergent vegetation	No	Endangered	Threatened
Western toad (<i>Bufo boreas</i>)	Still water in ponds and small lakes	No	Candidate	Species of concern
Birds				
Bald eagle (<i>Haliaeetus leucocephalus</i>)	Mature trees near water and prey sources	No	Sensitive	Species of concern
Common loon (<i>Gavia immer</i>)	Marine and large lakes and rivers	No	Sensitive	None
Great blue heron (<i>Ardea herodias</i>)	Fresh and salt-water wetlands, rivers	No	Priority	Monitor
Green heron (<i>Butorides striatus</i>)	Fresh water wetlands with forested habitat	No	None	None
Merlin (<i>Falco columbarius</i>)	Prairies and conifer forests	No	Candidate	None
Osprey (<i>Pandion haliaetus</i>)	Marine coasts, lakes, and rivers	No	None	None
Peregrine falcon (<i>Falco peregrinus</i>)	Cliffs and vegetated slopes	No	Sensitive	Species of concern
Pileated woodpecker (<i>Dryocopus pileatus</i>)	Forest with snags and downed wood	Yes (mature trees)	Candidate	None
Purple martin (<i>Progne subis</i>)	Large dead trees or artificial nesting structures near wetlands, ponds, or marine systems	Yes (mature trees)	Candidate	None
Red-tailed hawk (<i>Buteo jamaicensis</i>)	Open habitat near forests	Yes (mature trees)	None	None
Vaux's swift (<i>Chaetura vauxi</i>)	Old growth forest	No	Candidate	None
Western Grebe (<i>Aechmophorus occidentalis</i>)	Large lakes	No	Candidate	None

Common Name (Scientific Name)	Suitable Habitat	Potential Suitable Habitat Present Within Project Area	State Status	Federal Status
Fish/Salmon				
Bull trout (<i>Salvelinus confluentus</i>)	Marine, rivers, and streams	No	Candidate	Threatened
Chinook salmon (<i>Oncorhynchus tshawytscha</i>)	Marine, rivers, and streams	No	Candidate	Threatened
Coho salmon (<i>Oncorhynchus kisutch</i>)	Marine, rivers, and streams	No	Candidate	Species of concern
River lamprey (<i>Lampetra ayresi</i>)	Rivers and streams	No	None	Species of concern
Mammals				
Keen's myotis (<i>Myotis keenii</i>)	Mature coniferous forest	Yes (mature trees)	Candidate	None
Long-eared myotis (<i>Myotis evotis</i>)	Mature coniferous forest	Yes (mature trees)	Monitored	None
Long-legged myotis (<i>Myotis volans</i>)	Mature coniferous forest	Yes (mature trees)	Monitored	None
Western big-eared bat (<i>Plecotus townsendii</i>)	Mature coniferous forest	Yes (mature trees)	None	None
Reptiles				
Western pond turtle (<i>Clemmys marmorata</i>)	Ponds, sloughs, small lakes	No	Endangered	Species of concern

Note:

Sources: City of Bellevue 2013, WDFW 2013, Larsen 1997, and Larsen et al. 2004.

5.2 Wetlands

Table 5-2 Summary of Wetlands Located within the E360 Package

Wetland Name	Size (acres)	Drainage Basin	USFWS Classification	Hydrogeomorphic Classification Used for Rating
SR 520 West	0.64 ^a	Valley Creek	PFO, PSS, PEM	Depressional, Slope
Valley Creek	0.37 ^a	Valley Creek	PFO, PSS, PEM	Riverine, Slope
SR 520 East	0.23	Valley Creek	PFO, PSS, PEM	Slope

Notes:

a Approximate total wetland area, includes delineated area plus estimated wetland area extending outside Project area.

PFO = palustrine forested

PSS = palustrine scrub-shrub

PEM = palustrine emergent

PAB = palustrine aquatic bed

USFWS = U.S. Fish and Wildlife Service

Table 5-3 Summary of Wetland State and Local Ratings and City of Bellevue Buffer Widths for the E360 Package

Wetland Name	State (Ecology) and Local (Bellevue) Rating	Bellevue Buffer Widths (feet)
SR 520 West	III	60
Valley Creek	II	75
SR 520 East	III	60

Note:

Ecology = Washington State Department of Ecology

1 **Table 5-4 Summary of Wetland Impacts within the E360 Package**

Site	Drainage Sub-basin	Permanent Impact (acres)	Permanent Vegetation Conversion (acres)	Temporary Impact (acres)	Permanent Buffer Impact (acres)	Temporary Buffer Impact (acres)
SR 520 West	Valley Creek	0.01	0.23	0.00	0.01	0.55
Valley Creek	Valley Creek	0.00	0.01	0.00	0.01	0.27
Total Wetland Impacts:		0.01	0.24	0.00	0.02	0.82

2

5.3 Streams

Table 5-5 Summary of Streams Located within the E360 Package

Stream	OHWL Length ¹ (feet)	Drainage Basin ²
Valley Creek	205	Valley Creek

Notes:

1 Calculations provided by HJH for open channel areas that were delineated.

2 City of Bellevue 2013b.

OHWL = ordinary high water mark

Table 5-6 Local Critical Areas Regulations Stream Rating and Buffer Distance within the E360 Package

Stream	Local Stream Rating ¹	Buffer Width (feet)
Valley Creek	Type F	50 ²

Notes:

1 BCC (City of Bellevue 2013a).

2 Buffer is measured from Top of Bank.

6.0 Coal Creek Mitigation Site

6.1 Species of Local Importance

Table 6-1 Species of Local Importance Potential Presence within Coal Creek Mitigation Site

Common Name (Scientific Name)	Suitable Habitat	Potential Suitable Habitat Present Within Project Area	State Status	Federal Status
Amphibians				
Oregon spotted frog (<i>Rana pretiosa</i>)	Ponds and lakes with dense emergent vegetation	No	Endangered	Threatened
Western toad (<i>Bufo boreas</i>)	Still water in ponds and small lakes	No	Candidate	Species of concern
Birds				
Bald eagle (<i>Haliaeetus leucocephalus</i>)	Mature trees near water and prey sources	Yes (Coal Creek habitat)	Sensitive	Species of concern
Common loon (<i>Gavia immer</i>)	Marine and large lakes and rivers	No	Sensitive	None
Great blue heron (<i>Ardea herodias</i>)	Fresh and salt-water wetlands, rivers	Yes (Coal Creek habitat)	Priority	Monitor
Green heron (<i>Butorides striatus</i>)	Fresh water wetlands with forested habitat	Yes (Coal Creek habitat)	None	None
Merlin (<i>Falco columbarius</i>)	Prairies and conifer forests	No	Candidate	None
Osprey (<i>Pandion haliaetus</i>)	Marine coasts, lakes, and rivers	Yes (Coal Creek habitat)	None	None
Peregrine falcon (<i>Falco peregrinus</i>)	Cliffs and vegetated slopes	No	Sensitive	Species of concern
Pileated woodpecker (<i>Dryocopus pileatus</i>)	Forest with snags and downed wood	Yes (Coal Creek and mature trees)	Candidate	None
Purple martin (<i>Progne subis</i>)	Large dead trees or artificial nesting structures near wetlands, ponds, or marine systems	Yes (Coal Creek and mature trees)	Candidate	None
Red-tailed hawk (<i>Buteo jamaicensis</i>)	Open habitat near forests	Yes (Coal Creek and mature trees)	None	None
Vaux's swift (<i>Chaetura vauxi</i>)	Old growth forest	No	Candidate	None
Western Grebe (<i>Aechmophorus occidentalis</i>)	Large lakes	No	Candidate	None

Common Name (Scientific Name)	Suitable Habitat	Potential Suitable Habitat Present Within Project Area	State Status	Federal Status
Fish/Salmon				
Bull trout (<i>Salvelinus confluentus</i>)	Marine, rivers, and streams	Yes (Coal Creek)	Candidate	Threatened
Chinook salmon (<i>Oncorhynchus tshawytscha</i>)	Marine, rivers, and streams	Yes (Coal Creek)	Candidate	Threatened
Coho salmon (<i>Oncorhynchus kisutch</i>)	Marine, rivers, and streams	Yes (Coal Creek)	Candidate	Species of concern
River lamprey (<i>Lampetra ayresi</i>)	Rivers and streams	Yes (Coal Creek)	None	Species of concern
Mammals				
Keen's myotis (<i>Myotis keenii</i>)	Mature coniferous forest	Yes (Coal Creek habitat and mature trees)	Candidate	None
Long-eared myotis (<i>Myotis evotis</i>)	Mature coniferous forest	Yes (Coal Creek habitat and mature trees)	Monitored	None
Long-legged myotis (<i>Myotis volans</i>)	Mature coniferous forest	Yes (Coal Creek habitat and mature trees)	Monitored	None
Western big-eared bat (<i>Plecotus townsendii</i>)	Mature coniferous forest	Yes (Coal Creek habitat and mature trees)	None	None
Reptiles				
Western pond turtle (<i>Clemmys marmorata</i>)	Ponds, sloughs, small lakes	No	Endangered	Species of concern

6.2 Wetlands

Table 6-2 Summary of Wetlands Located within Coal Creek Mitigation Site

Wetland Name	Size (acres)	Drainage Basin	USFWS Classification	Hydrogeomorphic Classification Used for Rating
Wetland D ^a	>1.00	Coal Creek	PFO, PEM	Riverine

Notes:

a Wetland delineation provided by Evans and Associates (2007).

PFO = palustrine forested

PSS = palustrine scrub-shrub

PEM = palustrine emergent

PAB = palustrine aquatic bed

USFWS = U.S. Fish and Wildlife Service

Table 6-3 Summary of Wetland State and Local Ratings and City of Bellevue Buffer Widths for Coal Creek Mitigation Site

Wetland Name	State (Ecology) and Local (Bellevue) Rating	Bellevue Buffer Widths (feet)
Wetland D	II	110

Note:

Ecology = Washington State Department of Ecology

1 **Table 6-4 Summary of Wetland Impacts within Coal Creek Mitigation Site**

Site	Drainage Sub-basin	Permanent Impact (acres)	Permanent Vegetation Conversion (acres)	Temporary Impact (acres)	Permanent Buffer Impact (acres)	Temporary Buffer Impact (acres)
Wetland D	Coal Creek	0.00	0.00	0.10	0.00	N/A ^a
Total Wetland Impacts:		0.00	0.00	0.10	0.00	N/A

2 Note:

3 a See Section 2.2.4.4 of Critical Areas Report.

6.3 Streams

Table 6-5 Summary of Streams Located within Coal Creek Mitigation Site

Stream	OHWL Length ¹ (feet)	Drainage Basin ²
Coal Creek	750	Coal Creek

Notes:

- 1 Calculations provided by HJH for open channel areas that were delineated.
 - 2 City of Bellevue 2013b.
- OHWL = ordinary high water mark

Table 6-6 Local Critical Areas Regulations Stream Rating and Buffer Distance within Coal Creek Mitigation Site

Stream	Local Stream Rating ¹	Buffer Width (feet)
Coal Creek	Type F	100

Notes:

- 1 BCC (City of Bellevue 2013a).

Table 6-7 Summary of Stream Impacts within the Coal Creek Mitigation Site

Stream	Local Stream Rating	Permanent Impacts (sf)	Temporary Impacts (sf)	Permanent Buffer Impacts ¹ (acres)	Temporary Buffer Impacts (acres)
Coal Creek	Type F	0	10,736	0.00	0.00
Total Stream Impacts:		0	10,736	0.00	0.00

Notes:

- 1 Areas only include stream buffer where there is no wetland buffer overlap. Overlapping buffer areas are counted as wetland buffers and included in Table 4-4.
- sf = square feet

7.0 References

- City of Bellevue, 2013a. Bellevue City Code.
URL: <http://www.codepublishing.com/wa/bellevue/> (accessed September 2013).
- City of Bellevue, 2013b. Critical Areas Maps.
URL: <http://nwmaps.net/mapsearch.htm?theme=environmental> (accessed September 2013).
- Larsen, E.M., editor, 1997. *Management Recommendations for Washington's Priority Species, Volume III: Amphibians and Reptiles*. Washington Department of Fish and Wildlife, Olympia, Washington.
- Larsen, E.M., J. M. Azerrad, and N. Nordstrom (editors), 2004. *Management Recommendations for Washington's Priority Species, Volume IV: Birds*. Washington Department of Fish and Wildlife, Olympia, Washington.
- WDFW (Washington Department of Fish and Wildlife), 2013. Priority Habitats and Species Maps.

Appendix G
FEMA Habitat Assessment

1 **East Link | South Bellevue to Overlake Transit Center**
2 **Contract No. RTA/AE 0143-11**

3 **East Link Light Rail Extension**
4 **Critical Areas Report and Mitigation Plan**
5 **Appendix G: FEMA Habitat Assessment**
6
7
8
9
10
11
12
13

14 **June 5, 2015**

15 **Prepared for:**



Prepared by:



FINAL DESIGN PARTNERS.



TABLE OF CONTENTS

1.0	Project Area	1
2.0	Baseline Conditions.....	9
2.1	Sweyolocken Mitigation Site.....	9
2.2	Coal Creek Stream Enhancement.....	10
3.0	Project Description	11
3.1	Sweyolocken Mitigation Site.....	11
3.2	Coal Creek Mitigation Site.....	11
3.3	Protection Measures.....	12
4.0	Species Information and Site Use	13
4.1	Chinook Salmon	13
4.2	Steelhead	14
4.3	Bull Trout.....	14
5.0	Species Impacts.....	15
5.1	Direct Effects on Salmonids	15
5.1.1	Water Quality.....	15
5.1.2	Other Effects	15
5.2	Indirect Effects on Salmonids.....	15
5.2.1	Floodplain Refugia.....	15
5.2.2	Flood Storage	16
5.2.3	Water Quality.....	16
5.2.4	Floodplain Vegetation.....	16
5.3	Cumulative Impacts.....	17
6.0	Critical Habitat	18
6.1	Chinook Salmon	18
6.2	Steelhead	18
6.3	Bull Trout.....	18
7.0	Determination of Effects.....	19
8.0	References	20

List of Tables

Table G-1	Determination of Effect.....	19
-----------	------------------------------	----

List of Figures

Figure G-1	Vicinity Map and Project Alignment for Sweyolocken.....	3
Figure G-2	Floodplain Boundary at Sweyolocken	4
Figure G-3	FEMA FIRM for Sweyolocken	5

Figure G-4 Vicinity Map and Project Alignment for Coal Creek..... 6
Figure G-5 FEMA FIRM for Coal Creek 7
Figure G-6 Water Surface Elevation Analysis..... 8

LIST OF ACRONYMS AND ABBREVIATIONS

AkF	Alderwood and Kistap soils
BMP	best management practice
DPS	distinct population segment
EFH	essential fish habitat
ESU	evolutionary significant unit
FEMA	Federal Emergency Management Agency
FIRM	Flood Insurance Rate Map
FR	Federal Register
I-405	Interstate 405
I-90	Interstate 90
LWD	large woody debris
NAVD88	North American Vertical Database 1988
Project	East Link Extension Project
Sk	Seattle muck
So	Snohomish silt loam
Sound Transit	Central Puget Sound Regional Transit Authority
TESC	temporary erosion sediment control
Ur	Urban land
USFWS	U.S. Fish and Wildlife Service
WDFW	Washington Department of Fish and Wildlife

1.0 Project Area

The Central Puget Sound Regional Transit Authority (Sound Transit) proposes to construct and operate an eastern extension of its East Link light rail transit system providing urban transportation improvements in the central Puget Sound metropolitan region. The proposed light rail extension, known as the East Link Extension Project (Project), would connect to the existing light rail system in Downtown Seattle and extend the system east to Mercer Island, Bellevue, and Redmond, improving transportation connectivity between Seattle and these communities. The 7.13-mile Project occurs between Interstate 90 (I-90) on the east side of Lake Washington in Bellevue and State Route 520 in Redmond (Figure 1).

The Project area is located within the Cedar-Sammamish watershed, Water Resource Inventory Area 8. Five environmental resource mitigation sites are proposed that will be designed to partially compensate for stream and wetland impacts associated with the Project. Of these five sites, two may result in impacts within the floodplain.

The first is a wetland mitigation site, identified as the Sweyolocken mitigation site. It is on City of Bellevue-owned property located within the 350-plus-acre Mercer Slough wetland complex. The site is currently zoned as R-1 (Single-Family Residential Estate), and the current land use is agricultural, for blueberry farming. Mercer Slough comprises the lower drainage of Kelsey Creek, and the Sweyolocken mitigation site is located just upstream from the mouth of Mercer Slough at Lake Washington, north of the Sweyolocken Boat Launch and east of I-90 on Bellevue Way SE in the City of Bellevue, King County, Washington, Section 5 of T24N, R05E (parcel 7000100210) (Figure 2). Approximately 20 percent of the Sweyolocken mitigation site is within the mapped floodplain of the Mercer Slough based on the Federal Emergency Management Agency (FEMA) revised 1995 Flood Insurance Rate Map (FIRM; Figure 3). The elevations in the Sweyolocken mitigation site are at or below the Base Flood Elevation of 18.8 feet North American Vertical Database 1988 (NAVD88). A Channel Migration Zone has not been mapped for Mercer Slough or the West Channel of Mercer Slough, and given the low channel gradient and associated low energy level available to drive bank erosion, no channel migration is anticipated.

The second, a stream mitigation site identified as the Coal Creek Stream Enhancement Project, is also on City-owned property located within the Coal Creek Natural Area approximately 500 feet downstream of a residential development, and approximately 400 feet upstream of Interstate 405 (I-405). The Coal Creek Natural Area is heavily vegetated with native trees and shrubs. This segment of Coal Creek lies within the middle reach of the Coal Creek basin on the south side of Coal Creek parkway in the City of Bellevue, King County, Washington, Section 16 of T24N, R05E (parcel 1624059152) (Figure 4).

The reach of Coal Creek that will be affected by the proposed mitigation is mapped as “Zone A” (no base flood elevations determined) on the most recent FIRM (Figure 5). Although the regulatory base flood elevation of the creek is not established, the mitigation actions will occur within the floodplain. In this case, the City of Bellevue’s Land Use Code requires proponents of the Project to demonstrate that the

flood-carrying capacity of the floodway will not be diminished, and that the flood elevation in the area will not increase (Herrera 2015).

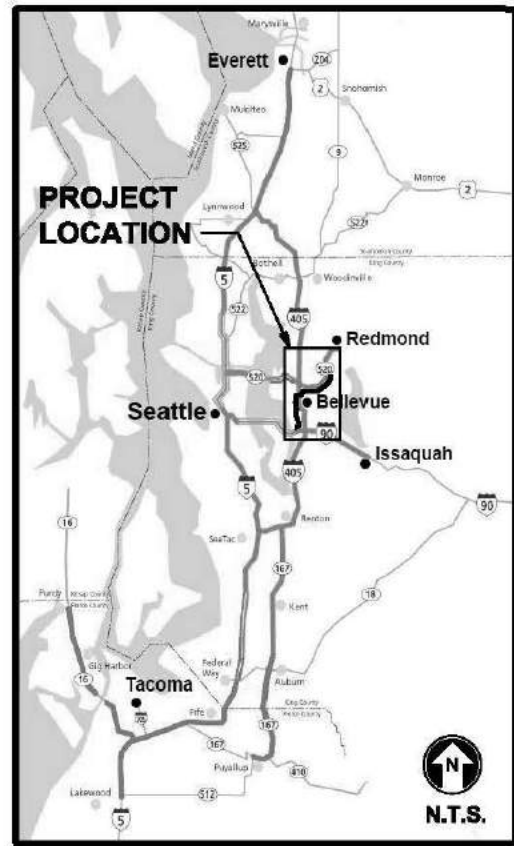
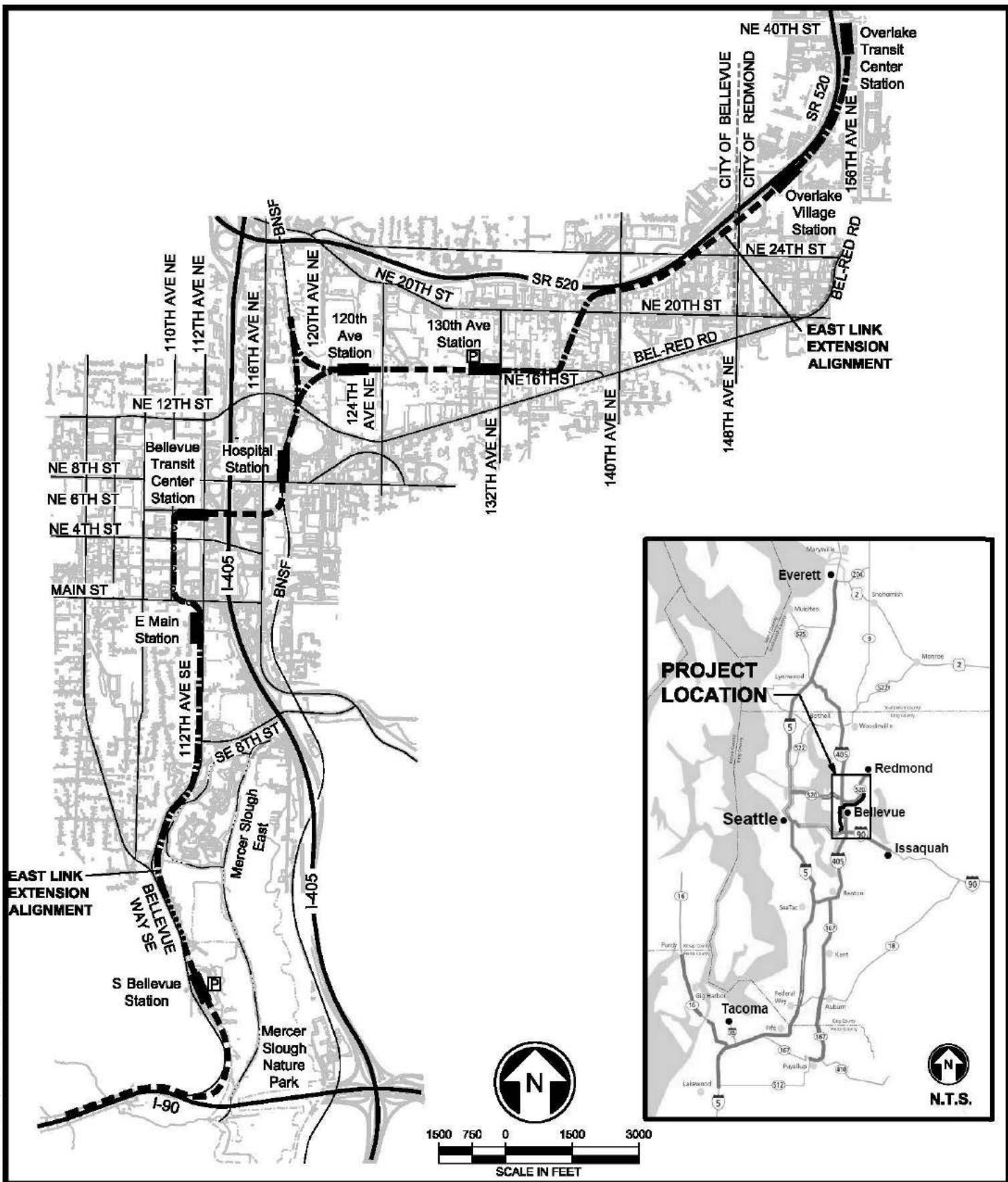

- LEGEND**
- — — — — ELEVATED GUIDEWAY
 - TRENCHED GUIDEWAY
 - — — — — RETAINED CUT-FILL/AT GRADE GUIDEWAY
 - — ○ — ○ — ○ TUNNELED GUIDEWAY
 - STATION
 - PARK-AND-RIDE

EAST LINK EXTENSION
SOUTH BELLEVUE TO OVERLAKE TRANSIT CENTER
FIGURE 1-1
VICINITY MAP AND PROJECT ALIGNMENT



12/11/13 | 9:57 AM | J.LOGAN
 J:\6626\CADD\0500\DRAWING\ARCH\CRITICAL AREAS REPORT\REPORT FIGURES\CART-1.DWG

01/07/14 | 5:19 PM | KSAUNDERS
J:\5229\CADD\DS001\DRAWINGS\ARCH\CRITICAL AREAS REPORT\REPORT FIGURES\CAR2.3.DWG

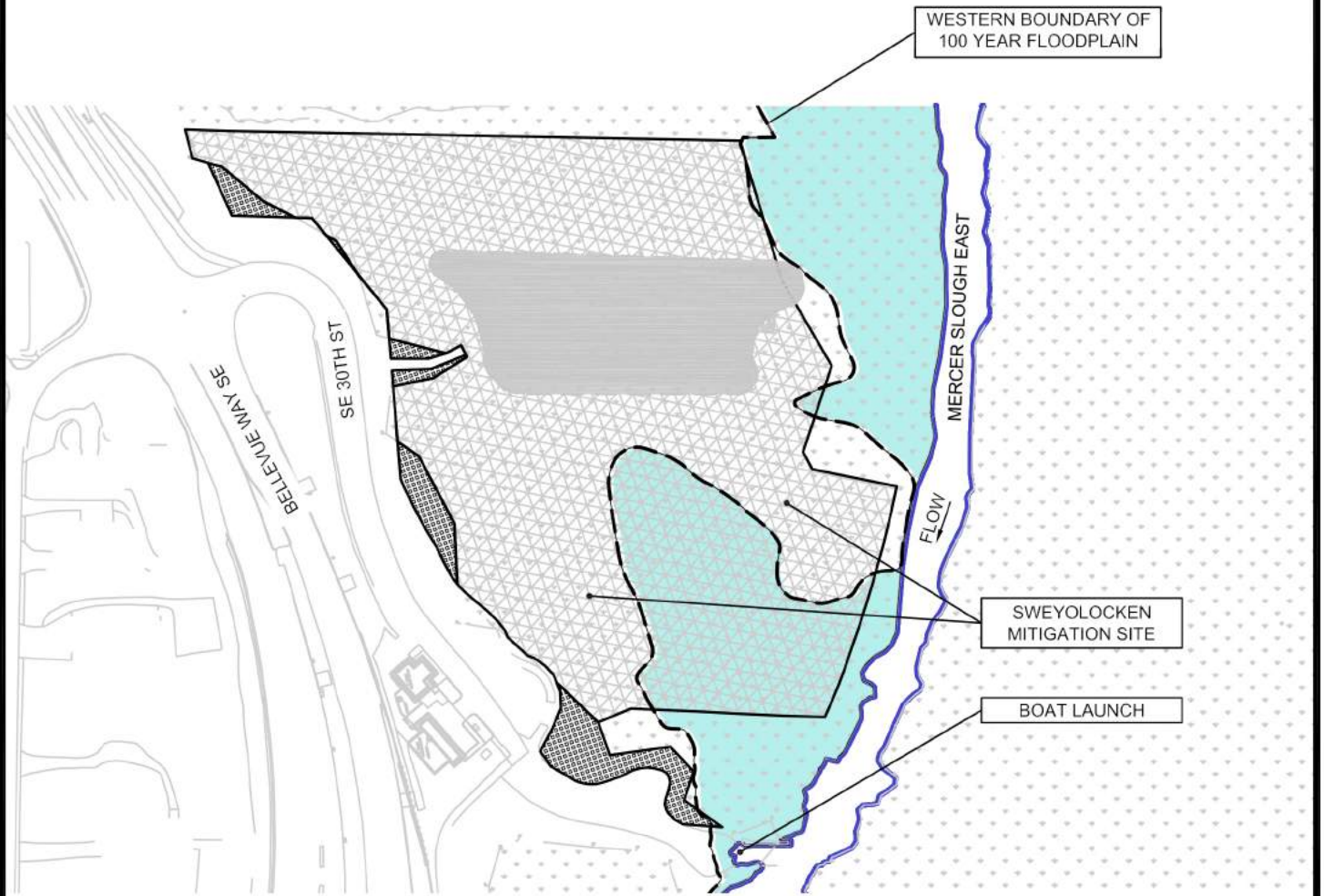

NOTES:

1. EARTHWORK IMPROVEMENTS WITHIN THE 100-YEAR FLOODPLAIN WILL BE BALANCED OR DECREASED. NO RISE IN BASE FLOOD ELEVATION IS ANTICIPATED.

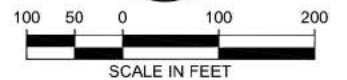

LEGEND

- 100 YEAR FLOODPLAIN BOUNDARY (AT ELEVATION 18.8' PER FIRM MAPS)
- 100 YEAR FLOODPLAIN
- STREAM OHWM



EAST LINK EXTENSION
SOUTH BELLEVUE TO OVERLAKE TRANSIT CENTER
FIGURE 2-3
FLOODPLAIN BOUNDARY AT SWEYOLOCKEN

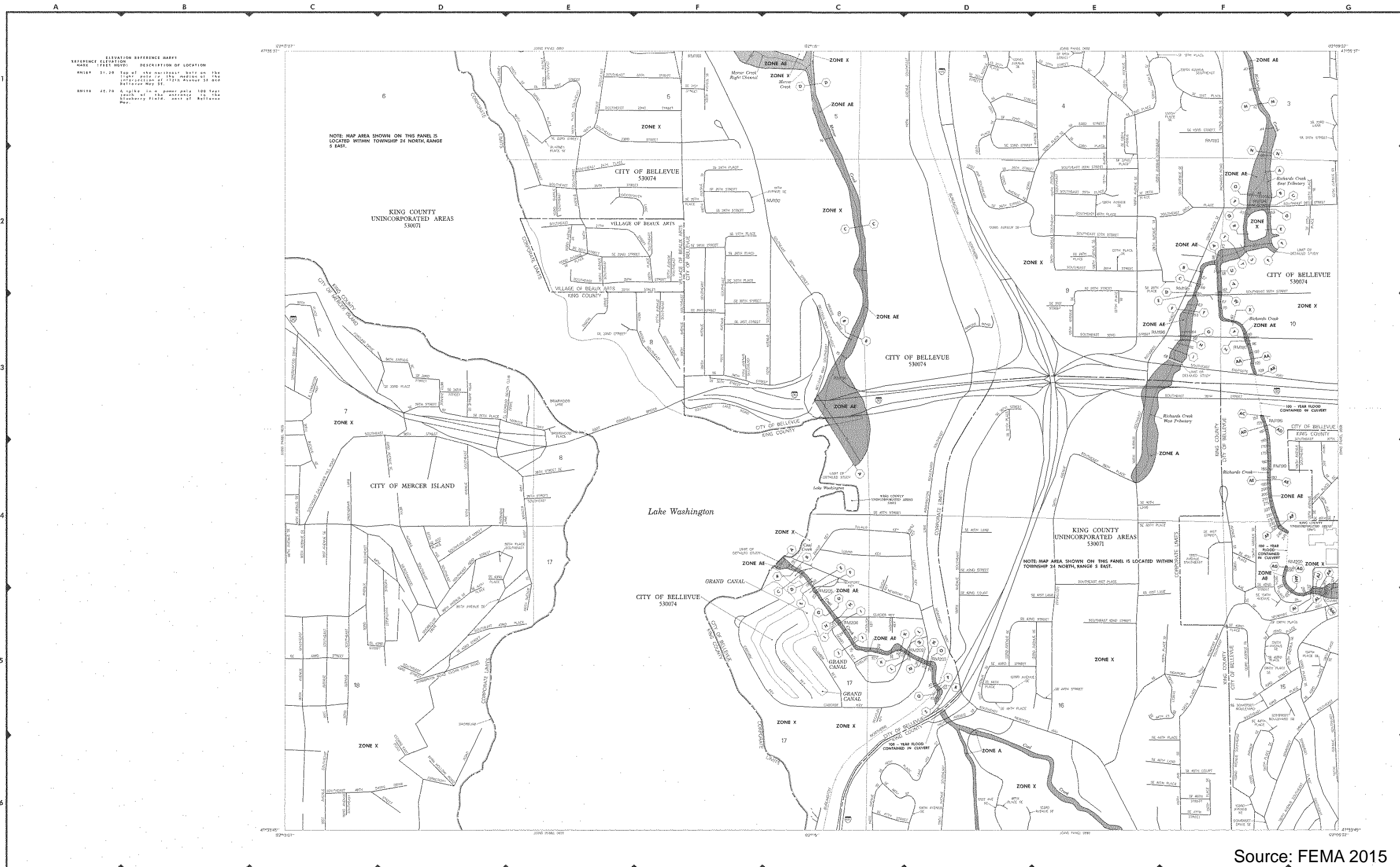

LEGEND

SPECIAL FLOOD HAZARD AREAS (INDICATED BY SHADING)

ZONE AE 100-Year Flood Hazard Area

ZONE X 100-Year Flood Hazard Area

ZONE V Coastal High Hazard Area

ZONE D Unincorporated Coastal Barriers

OTHER AREAS

UNINCORPORATED COASTAL BARRIERS

NOTES

MAP REPOSITORY

FIRM

APPROXIMATE SCALE IN FEET

NATIONAL FLOOD INSURANCE PROGRAM

FIRM

FLOOD INSURANCE RATE MAP

KING COUNTY, WASHINGTON AND INCORPORATED AREAS

PANEL 658 OF 1725

MAP NUMBER 530330658 F

MAP REVISED: MAY 18, 1995

Federal Emergency Management Agency

Source: FEMA 2015



EAST LINK EXTENSION
SOUTH BELLEVUE TO OVERLAKE TRANSIT CENTER
FIGURE G-3
FEMA FIRM FOR SWEYLOCKEN SITE

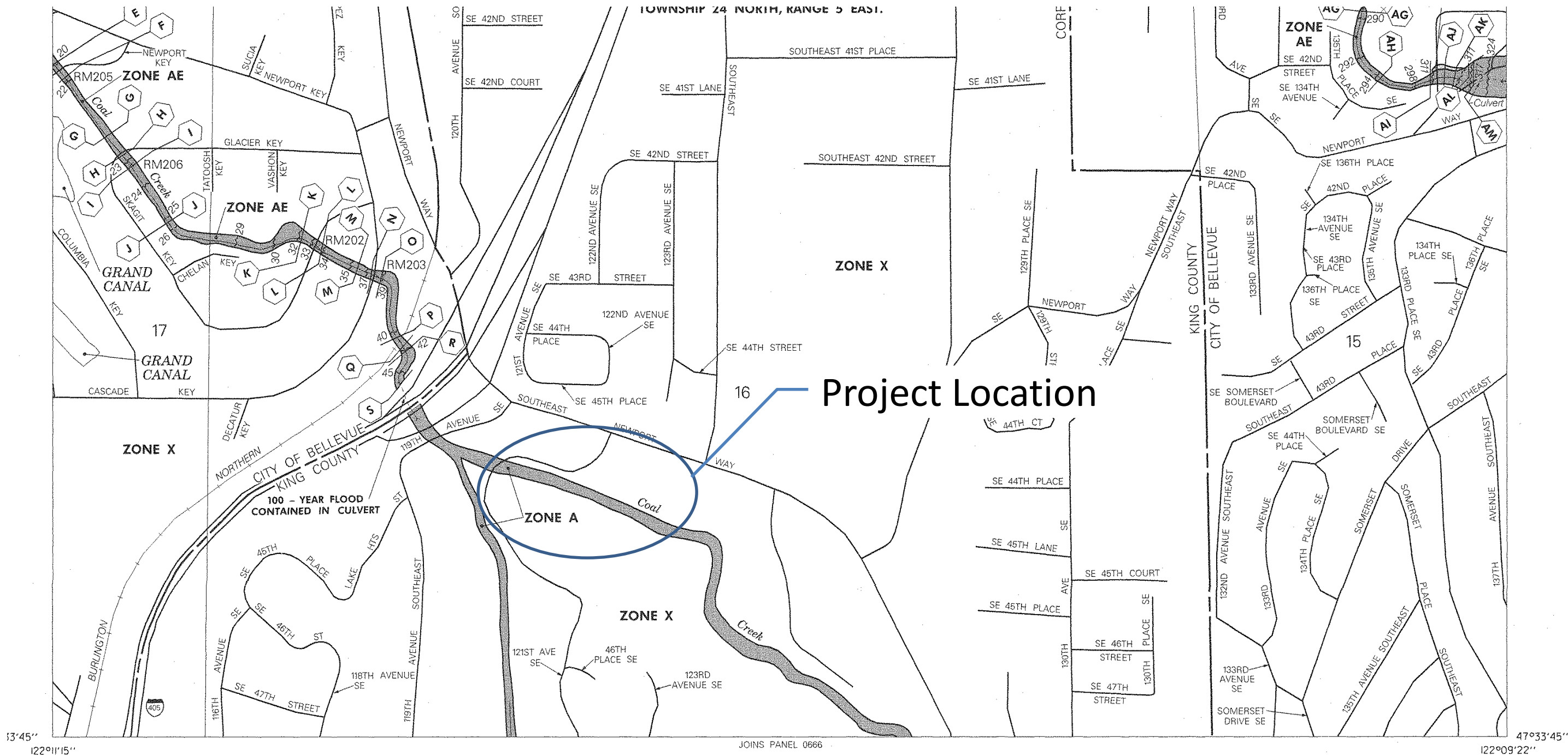

Source: FEMA 1995



FINAL DESIGN PARTNERS.



SOUNDTRANSIT

EAST LINK EXTENSION
SOUTH BELLEVUE TO OVERLAKE TRANSIT CENTER
FIGURE G-4
FLOODPLAIN BOUNDARY AT COAL CREEK

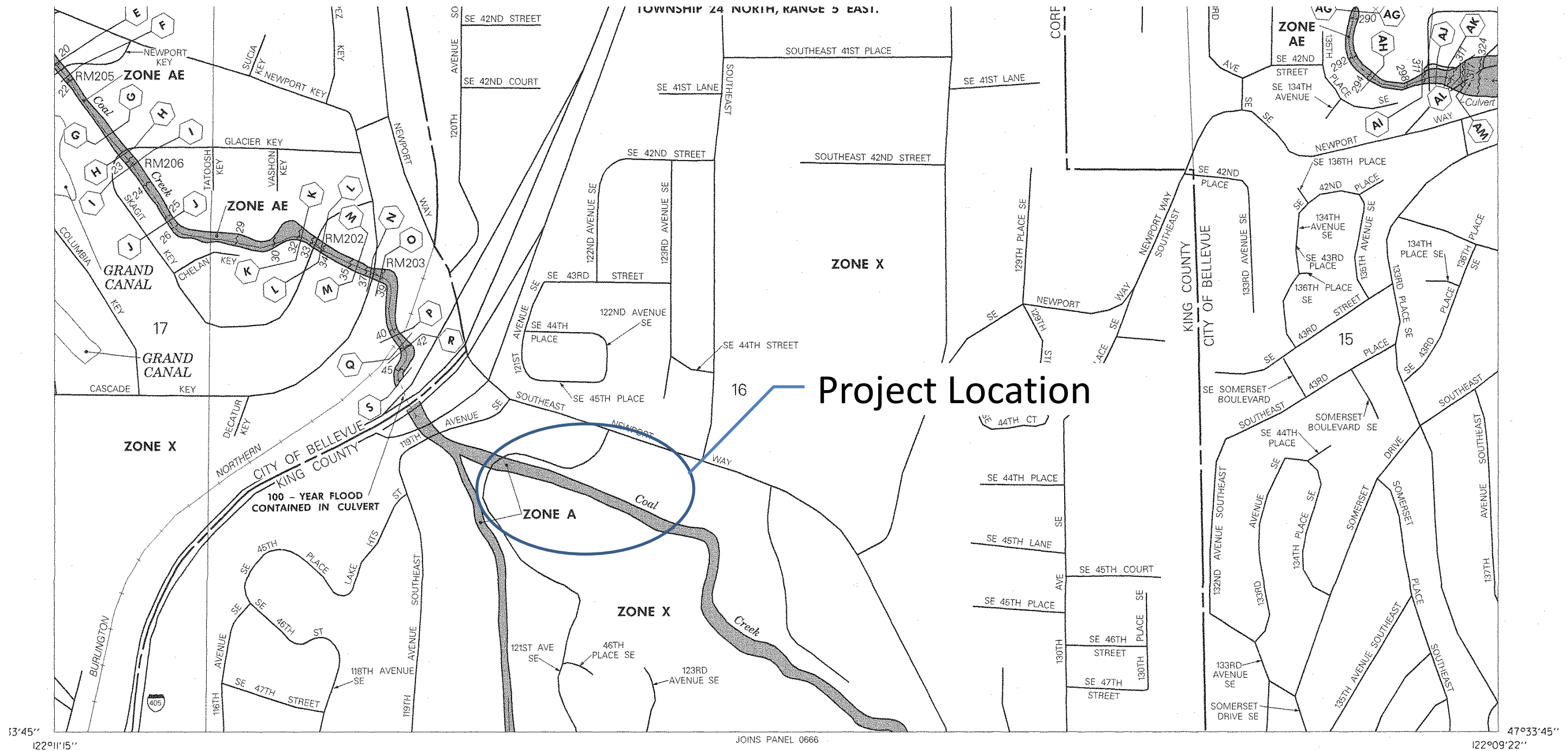

Project Location

Source: FEMA 1995



EAST LINK EXTENSION
 SOUTH BELLEVUE TO OVERLAKE TRANSIT CENTER
 FIGURE G-5
 FEMA FIRM AT COAL CREEK

Updated Model Domain

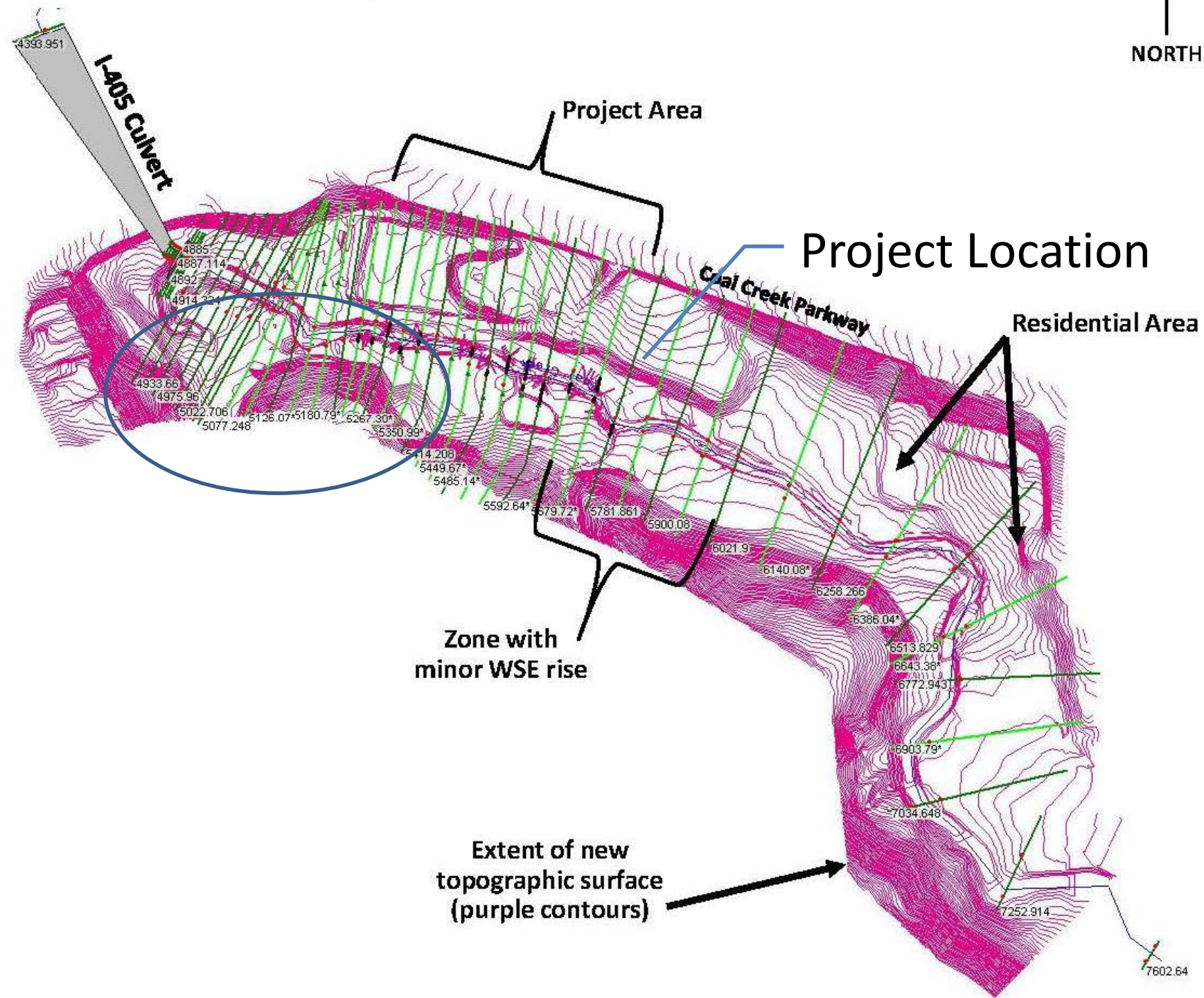

Source: Herrera 2015



2.0 Baseline Conditions

2.1 Sweyolocken Mitigation Site

The Sweyolocken mitigation site is a blueberry farm within the 350-plus-acre Mercer Slough wetland complex. Field investigations revealed that most or all of this area is within the existing jurisdictional wetland boundary. Efforts to alter the hydrology by draining the agricultural area are evident from two large ditches running perpendicular to Mercer Slough. Until recently, water has been pumped from the ditches to the slough, affecting the wetland hydrology. Historically, the Mercer Slough wetland complex was submerged, but when Lake Washington was lowered in 1916, the area began to form into a several-hundred-acre freshwater wetland complex. Portions of the wetland have been used to produce berries (primarily blueberries), although most of the complex is now in restoration or in relatively natural condition.

Current elevations in the site range from approximately 17.53 to 26.3 feet NAVD88. The Base Flood Elevation at this site is 18.8 feet and approximately 80% of the mitigation site is at or below this elevation. The hydrology of the site is currently being studied, but is primarily controlled by Lake Washington. The elevation of Lake Washington is controlled at the Chittenden Locks in Ballard. Typical water surface elevations are about 2 feet higher at the maximum in late spring or early summer than at their minimum in late fall or early winter. Surface water flows from Mercer Slough, direct precipitation, and runoff also affect the site hydrology.

The site soils are mapped by the Natural Resource Conservation Service Web Soil Survey as Seattle Muck (Sk) in the north and Snohomish silt loam (So) to the south (USDA 2013). Field investigations of soils by Anchor QEA ecologists indicate that the entire site is underlain by peat or stratified peat and muck below a depth of about 12 to 14 inches. Above the peat the soils are very dark and very poorly drained, and range in texture from silt loam to muck. The water table at the site ranges from the surface to a depth greater than 18 inches.

Land use near the blueberry farm includes a recreational bike/pedestrian trail system, the Sweyolocken boat launch into Lake Washington, the Sweyolocken sewage pump facility, and paved access roads and parking areas. Forested, scrub-shrub, and emergent wetland systems are located adjacent to the blueberry farm. Dominant tree vegetation includes Poplar (*Populus spp.*), Pacific willow (*Salix lucida*), red alder (*Alnus rubra*), western red cedar (*Thuja plicata*), and paper birch (*Betula papyrifera*). Red-osier dogwood (*Cornus sericea*), hardhack spirea (*Spiraea douglasii*), salmonberry (*Rubus spectabilis*), and blackberry (*Rubus armeniacus*) are common in the scrub-shrub layer. Emergent cover is dominated by reed canarygrass (*Phalaris arundinacea*), cattails (*Typha latifolia*), soft rush (*Juncus effusus*), small bedstraw (*Gallium trifidum*), and spike rush (*Eleocharis palustris*).

Mercer Slough is characterized by a low velocity, broad, relatively uniform channel. Mercer Slough suffers from high water temperatures and low dissolved oxygen levels, particularly in late-summer and early-fall, which are not preferable to salmon and other fish and aquatic life.

2.2 Coal Creek Stream Enhancement

The Coal Creek Stream Enhancement site is located within the Coal Creek Natural Area on the south side of Coal Creek Parkway and east of I-405. A gravel access road runs through the site from the Parkway to the Project area and appears to have been used for construction of the existing in-stream control structure or for the existing sewer line along the south side of the creek. No side channels exist within the Project site.

The creek channel ranges from 10 to 20 feet wide. The channel banks vary from about 3H:1V to vertical and give way to a 40-foot-wide bench along the left and right banks. Current water elevations in the site range from approximately 74.48 to 95.01 feet NAVD88. As stated above, the Base Flood Elevation at this site has not been established. Two branches of Coal Creek meet in this region. Hydrology is partly influenced by subsurface flow from upland slopes (Adolfson 2006).

The site soils are mapped by the Natural Resource Conservation Service as Alderwood and Kitsap soils (AkF) in the south and Urban land (Ur) in the north (USDA 2015). Field investigations from 2006 indicate that the soil is a 7-inch layer of black sandy loam over a very dark grayish brown gravelly sand loam.

Land use near this reach of Coal Creek includes I-405, a King County Trail, and the Woodsong Condominiums. Forested wetland systems are located in the vicinity. Dominant tree vegetation includes red alder. Himalayan blackberry is common in the scrub-shrub layer. Emergent cover is dominated by reed canarygrass and bentgrass (*Agrostis* spp.). The Coal Creek stream gradient ranges from low to moderate, while some of its tributaries have very high gradients; this is consistent with an urbanized watershed. The benthic community is indicative of relatively poor ecologic conditions (COB 2003).

3.0 Project Description

3.1 Sweyolocken Mitigation Site

The proposed Sweyolocken wetland mitigation will compensate for wetland impacts in the southern areas of the Project. The rehabilitation of wetland hydrology and vegetation enhancement will create a diverse, complex habitat structure to support a much greater diversity of species than are supported by the site's current agricultural use. This variety of species will provide diversity to increase the opportunity to meet specific habitat requirements of a variety of fauna. The Sweyolocken site will include habitat features such as standing snags, downed large woody material, brush, and boulder piles. Evidence of wildlife use will be documented in the monitoring program. Topographic adjustments will be made to rehabilitate hydrology and create niches for forested, shrub-scrub, and emergent wetland types. Small topographic depressions will be created that not only support obligate emergent vegetation, but that will also increase the hydrologic and water quality function of the wetland.

The primary site constraint is access, and beyond a few existing roads, care will be taken to avoid soil compaction during construction using wetland soil mats or plates. Existing roads, and all associated culverts and other drainage infrastructure encountered, will be decommissioned, and associated soils will be de-compacted and amended as needed.

3.2 Coal Creek Mitigation Site

The Coal Creek Mitigation will consist largely of installing large woody debris (LWD) in the reach of the stream. LWD placements in the active channel are anticipated to provide localized scour, stimulating the creation of pool-riffle sequences that will provide improved habitat. Pools provide holding areas for adults moving upstream through the system, and rearing habitat for juveniles. Riffles provide spawning habitat for adults and favorable conditions for benthic invertebrates that are an important food source for juveniles. The design of this project will be based on the Washington Department of Fish and Wildlife (WDFW) Stream Habitat Restoration Guidelines (Cramer 2012). This specifically applies to target wood loading within the mitigation site at or above the median for reference streams in the same size and bio-geographic class (Fox and Bolton 2007). The site is currently forested, with a mix of deciduous and coniferous species. Mitigation planting is anticipated to be minimal. Native plantings will be planted in areas that were disturbed as a result of construction and will match the species and spacing that were originally installed as part of the buffer mitigation.

An existing laydown and staging area is available adjacent to the site that provides excellent access to the stream. Equipment access to the stream for LWD installation may require some localized vegetation removal, but it is believed that this can be limited to low growing shrubs, and that impacts to mature trees can be avoided. All access areas will be restored and re-vegetated to match previous conditions where feasible.

3.3 Protection Measures

The use of Temporary Erosion and Sedimentation Controls (TESC) during and after construction will help minimize potential water quality impacts on the aquatic environment. All available and appropriate best management practices (BMPs) will be implemented, including but not limited to establishing and marking clearing limits, covering exposed soils, and establishing a construction entrance.

Specific avoidance and minimization measures include the following:

- Installing a retaining wall at 15th Street to avoid additional impacts to Bellefield South and Bellefield North wetlands
- Shifting the alignment to south and elevating the guideway to have a minimum 15-foot clearance, to minimize impacts to Kelsey West Tributary Pond wetland
- Providing a fish passable crossing at Goff Creek (which is not currently fish passable)
- Providing accommodations for future fish passage by other at the crossing of the Unnamed Tributary to Kelsey Creek (which is not currently fish passable)
- Pipe discharge locations are dictated by the need to meet a certain topographic elevation, and in some cases, that impacts wetlands. Avoidance and minimization will occur where possible by either moving discharge locations or converting the design into a swale (versus pipe).
- The existing detention water quality pond at South Bellevue station was constructed in 1980. Due to the reconstruction of the site, this pond will be modified to accommodate the new stormwater requirements. The pond will be expanded towards existing parking lot, within the wetland buffer.

4.0 Species Information and Site Use

The Project area is within the geographic range of three Endangered Species Act-listed species of salmonids:

- Chinook salmon (*Oncorhynchus tshawytscha*) of the Puget Sound Evolutionary Significant Unit (ESU) (threatened)
- Steelhead (*O. mykiss*) of the Puget Sound Distinct Population Segment (DPS) (threatened)
- Bull trout (*Salvelinus confluentus*) of the Coastal-Puget Sound DPS (threatened)

Critical habitat for Chinook salmon includes the Lake Washington Subbasin (Watershed Code 17110012-03) of the Puget Sound ESU (U.S. Federal Register [FR], 2 September 2005). The final rule excludes all tributaries to Lake Washington, including Mercer Slough and Coal Creek, from the final critical habitat designation for Chinook salmon. Critical habitat of Coastal-Puget Sound bull trout includes Lake Washington, but does not include the Mercer Slough system. Critical habitat has been proposed but is not currently designated for Puget Sound steelhead.

Chinook salmon are also designated as an essential fish habitat (EFH) species, managed by the National Oceanic and Atmospheric Administration's National Marine Fisheries Service (U.S. FR, 15 October 2008).

4.1 Chinook Salmon

The Puget Sound ESU includes all Chinook salmon spawned in tributaries to the Puget Sound, including Lake Washington, Mercer Slough, and Coal Creek. WDFW's SalmonScape website indicates that Mercer Slough is used as rearing habitat by Chinook salmon, and Coal Creek contains documented presence of the species (WDFW 2015). Although use of the West and East Channel of Mercer Slough is not specifically indicated by the SalmonScape mapping, it is assumed that Chinook salmon may also rear in and migrate through the West and East Channels.

Adult spawning Chinook salmon enter Lake Washington from early July through the end of October. Residence time in the lake is thought to be relatively brief. When tributary temperatures drop in fall, Chinook salmon migrate into the tributary streams and rivers to spawn. All Chinook salmon in the Lake Washington system are "ocean-type"; they rear in freshwater as juveniles for only 3 to 6 months. There are two juvenile life-history variants in the population. One variant enters the lake as fry and rears in the lake until late spring/early summer before entering Puget Sound. The second variant rears in streams until late spring/early summer before migrating into and through the lake and out to sea. The second type is the most common and does not spend much time in Lake Washington. Chinook salmon fry outmigrate during the spring and can be found in Lake Washington between March and August, with peak abundance from May through July (Axis Environmental and CH2M Hill 2010).

A final critical habitat designation was formalized for Puget Sound ESU Chinook salmon on August 12, 2005 (70 U.S. FR 52630), specifically including Unit 10, the Lake Washington sub-basin. The final rule excludes all tributaries to Lake Washington, including Mercer Slough and Coal Creek, from the final critical habitat designation for Chinook salmon (70 U.S. FR 52698).

4.2 Steelhead

Federally threatened steelhead occur in Lake Washington, and have been documented in both Mercer Slough and Coal Creek (WDFW 2015). Both anadromous (steelhead) and resident (rainbow trout) life forms of *O. mykiss* are present in the Lake Washington basin (Axis Environmental and CH2M Hill 2010).

WDFW described the Lake Washington watershed winter steelhead population as critical in 2002. Winter steelhead enter freshwater from November to April. The presence of adult steelhead peaks between January and May, and juveniles peak between May and July. The duration of freshwater rearing can range from 1 to 7 years before smoltification. Residual steelhead are present in Lake Washington year-round (Axis Environmental and CH2M Hill 2010). Critical habitat for Puget Sound DPS steelhead has been proposed, but has not been designated.

4.3 Bull Trout

Bull trout are not commonly observed within the Lake Washington basin, and are not identified to occur in Coal Creek or Mercer Slough (WDFW 2015). While their presence is low in the lake, sub-adult bull trout are present year-round, with a potential increase in numbers between April and June. The U.S. Fish and Wildlife Service (USFWS) considers Lake Washington potential foraging, migration, and overwintering habitat for bull trout (USFWS 2004). There is no known spawning subpopulation resident in Lake Washington. The presence of bull trout in Mercer Slough near the action area is very unlikely (Axis Environmental and CH2M Hill 2010).

USFWS published the final rule on designated critical habitat for Coastal-Puget Sound DPS bull trout in September 2005 (70 U.S. FR 56212). Tributary streams in Lake Washington are excluded from designated critical habitat.

5.0 Species Impacts

The likely effects of the proposed mitigation activity on listed species and habitat conditions in Mercer Slough are described below. As described previously, only Project elements associated with the Sweyolocken and Coal Creek mitigation sites are evaluated in this report, as they are the only East Link Extension Project elements that may result in impacts within the FEMA-mapped floodplain of Mercer Slough. The proposed mitigation activity could potentially affect listed salmon species in generally similar manners. Thus, unless otherwise noted, there is no distinction between listed salmonids in the following discussion.

5.1 Direct Effects on Salmonids

5.1.1 Water Quality

Adverse direct effects of the proposed wetland and stream mitigation on salmonids are exceedingly unlikely because the proposed mitigation activities are limited to creating and restoring wetland and wetland buffer habitat, and will not result in any development or creation of impervious areas within the Mercer Slough floodplain or the Coal Creek floodplain. BMPs will be implemented to avoid any water quality impacts to Mercer Slough and Coal Creek. An approved TESC plan will be in place during construction, and erosion control measures will be enacted to limit the potential for sediment runoff during the rainy season. These measures, in addition to the proposed mitigation activities, will greatly reduce the possibility of construction causing any turbidity increase in Mercer Slough or Coal Creek. Any accidental spills of toxic substances will be contained on the site and cleaned immediately upon discovery. Any soiled materials will also be cleaned. Sedimentation will be avoided through the use of BMPs such as silt fencing and other barriers.

5.1.2 Other Effects

The proposed mitigation in Mercer Slough will not affect the bank stabilization, channel form, or habitat connectivity of the area. While the placement of LWD in Coal Creek could affect the channel form, it is anticipated that these changes will be beneficial to fish species in the area, creating more in-channel refugia and foraging grounds, and increasing the size, quality, and complexity of in-stream habitat features, such as pools and riffles. Wetland and wetland buffer habitat conditions will be improved compared to existing conditions. Construction noise will not affect the aquatic environment.

5.2 Indirect Effects on Salmonids

Delayed onset effects after the Project has been completed could potentially cause changes in habitat quality and availability, foraging conditions for juvenile salmonids, and forage fish of salmonids. Potential indirect effects on salmonids are described in the following sections.

5.2.1 Floodplain Refugia

In a natural setting, during high flows, floodwaters are temporarily stored as they stretch across the floodplain, providing juvenile salmonids with lower velocity rearing areas and reducing downstream flow velocities, thereby limiting potential scour of salmonid redds. The existing Sweyolocken and Coal

Creek mitigation sites do not represent beneficial floodplain rearing habitat, and therefore, habitat improvements in these areas will not adversely affect juvenile rearing potential during flood events, and may benefit them compared to existing conditions.

5.2.2 Flood Storage

The Project will not result in significant elevation change for the area. All work will be done below 19 feet NAVD88 and will have no net cut (removal of material) or no associated grading. Given the Sweyolocken mitigation site's position in the watershed, just upstream of Lake Washington, and the fine-grained nature of the substrate in Mercer Slough, no spawning is anticipated to occur downstream, so a reduction in flood storage capacity will not affect spawning salmon. In addition, because Lake Washington water levels are artificially controlled and the lake has a backwater effect on Mercer Slough near the site, downstream flood velocities are not a significant concern for migrating salmon or juveniles rearing downstream.

The material used as channel backfill in the Coal Creek mitigation site will improve conditions for salmon spawning and the productivity of a diverse benthic invertebrate community. Currently, much of the reach has substrate that is too fine to support spawning.

In summary, the effects of the proposed wetland mitigation on flood storage functions on the habitat and life history of salmonids are expected to be insignificant and may even improve habitat conditions within the Mercer Slough complex and within Coal Creek.

5.2.3 Water Quality

Urban stormwater can have significant detrimental impacts on salmonids. Sediments, heavy metals, polycyclic aromatic hydrocarbons, pesticides, and nutrients can enter the stream channel through erosion of the stream banks, road runoff, landslides, or overland flow. The proposed wetland mitigation in Mercer Slough will increase the area of native vegetation over a 5- to 6-acre area. By removing the blueberry plants and filling in the ditches, the proposed wetland mitigation is expected to improve water quality in the adjacent Mercer Slough wetlands. Revegetation of the Coal Creek stream mitigation site will provide soil stabilization, reducing the input of fine sediment that degrade rearing and spawning habitat for native fishes. Vegetation enhancements at the Coal Creek stream mitigation site will provide shade that will help maintain cooler water temperature.

5.2.4 Floodplain Vegetation

The farmed blueberry plants in Mercer Slough will be removed under the proposed wetland mitigation, and replaced with native vegetation. Because the blueberry farm is set back from the shoreline, adjacent to existing parking lots and pedestrian trails, the wetland mitigation is not expected to negatively affect inputs of organic material, shading, or the recruitment of LWD. Currently, there is not much vegetation between the blueberry farm and the slough shoreline. Mitigation efforts in the area may have beneficial impacts by restoring vegetation near the slough shoreline where currently there is poor riparian habitat.

The placement of LWD in Coal Creek is anticipated to increase the input of organic material into the stream channel and the recruitment of more large woody material. Enhancement of floodplain vegetation will remove invasive species and restore a native vegetation community to better shade and cool the stream and to provide insect drop and other organic input.

5.3 Cumulative Impacts

Cumulative impacts are those that occur over time as land use, landscape conditions, disturbance, and other factors in the Project area and surrounding area change. With the implementation of mitigation activities in the Swaylocken project area, recreational activities, such as blueberry-picking, walking, and bike-riding, will cease. Due to the cessation of these human activities, cumulative impacts on sensitive fish and wildlife species and their habitats are not considered significant and may be improved compared to existing conditions.

6.0 Critical Habitat

6.1 Chinook Salmon

Neither the Swaylocken mitigation site nor the Coal Creek Stream Enhancement site are included within designated critical habitat for Chinook salmon.

6.2 Steelhead

Critical habitat is currently under development for Puget Sound DPS steelhead.

6.3 Bull Trout

Neither the Swaylocken mitigation site nor the Coal Creek Stream Enhancement site are included within designated critical habitat for bull trout.

7.0 Determination of Effects

Determination of effects for species in the area are listed in Table 1. Implementation of the proposed wetland and stream mitigation in Sweyolocken and Coal Creek will have minimal, if any, effects on salmonids, and will improve habitat conditions within the Mercer Slough and Coal Creek systems compared to existing conditions. Direct, construction-related impacts will be avoided and minimized by implementing BMPs.

The proposed wetland mitigation may affect, but is not likely to adversely affect, Puget Sound ESU Chinook salmon, Coastal-Puget Sound DPS bull trout, and Puget Sound DPS steelhead.

The Sweyolocken and Coal Creek mitigation sites are not located within designated critical habitat for Puget Sound ESU Chinook salmon, Coastal-Puget Sound DPS bull trout, or Puget Sound DPS steelhead.

The collective impact of the proposed wetland mitigation may affect, but is not likely to adversely affect, Pacific salmon EFH.

Table G-1 Determination of Effect

Species	Overall Project Effect	Effect on Critical Habitat	Effect on EFH
Puget Sound ESU Chinook salmon	May affect, not likely to adversely affect	N/A	No adverse effect
Puget Sound DPS steelhead	May affect, not likely to adversely affect	N/A	N/A
Coastal-Puget Sound DPS bull trout	May affect not likely to adversely affect	N/A	N/A

Notes:

DPS = distinct population segment

EFH = essential fish habitat

ESU = evolutionary significant unit

N/A = not applicable

8.0 References

- Adolfson, 2006. Updated Wetland/Biology Report: I-405/112th Avenue SE to I-90 Project. Prepared for Washington State Department of Transportation. July 2006.
- Axis Environmental, LLC and CH2M Hill, 2010. *East Link Project Biological Assessment*. Prepared for Sound Transit. October 2010.
- COB (City of Bellevue), 2003. *Bellevue Critical Areas Update Streams Inventory*. March 2003.
- Cramer, Michelle L., 2012. *Stream Habitat Restoration Guidelines*. Michelle Cramer, managing editor. Co-published by the Washington Departments of Fish and Wildlife, Natural Resources, Transportation and Ecology, Washington State Recreation and Conservation Office, Puget Sound Partnership, and the U.S. Fish and Wildlife Service. Olympia, Washington.
- Fox, M.J., and S.M. Bolton, 2007. A regional and geomorphic reference for quantities and volumes of instream wood in unmanaged forested basins of Washington State. *North American Journal of Fisheries Management* 27(1): 342-359.
- Herrera, 2015. Coal Creek Stream Enhancement Project Hydraulic Effects. Prepared for Sound Transit. April 2015.
- USDA (U.S. Department of Agriculture), 2013. *Natural Resource Conservation Service (NRCS) Web Soil Survey*. Cited: November 10, 2013. Available from: <http://websoilsurvey.nrcs.usda.gov/app>.
- USDA, 2015. *Natural Resource Conservation Service (NRCS) Web Soil Survey*. Cited: May 20, 2015. Available from: <http://websoilsurvey.nrcs.usda.gov/app>.
- USFWS (U.S. Fish and Wildlife Service), 2004. *Draft Recovery Plan for the Coastal-Puget Sound Distinct Population Segment of Bull Trout (Salvelinus confluentus)*. Volume I (of II): Puget Sound Management Unit. Portland, Oregon. 389 + xvii pp.
- WDFW (Washington Department of Fish and Wildlife), 2015. SalmonScape Interactive mapper – Salmon presence; forage fish spawning habitat. Available from: <http://wdfw.wa.gov/mapping/salmonscape/>. Accessed on May 5, 2015.

Appendix H

Coal Creek Stream Enhancement Project Hydraulic Effects Memorandum

TECHNICAL MEMORANDUM

Date: April 16, 2015
To: Ellie Ziegler, Sound Transit
From: Ian Mostrenko, P.E., and Brian Scott, Herrera Environmental Consultants, Inc.
Subject: Coal Creek Stream Enhancement Project Hydraulic Effects

Introduction

This memorandum summarizes the results of a hydraulic analysis completed by Herrera for Sound Transit's Coal Creek Stream Enhancement Project (Project) in Bellevue, Washington. The project includes placing 80 pieces of large woody debris (LWD) within and along approximately 450 feet of the Coal Creek channel for habitat value to mitigate for construction impacts to streams and wetlands along Sound Transit's East Link corridor in Bellevue. The project is located within the Coal Creek Natural Area approximately 500 feet downstream of the Woodsong Condominiums residential development and approximately 400 feet upstream of the City of Bellevue's (City) Interstate 405 (I-405) sediment collection and flow control structure where Coal Creek flows under I-405 through a large culvert. The Coal Creek Natural Area is heavily vegetated with native trees and shrubs.

Logs for habitat improvement will be anchored in place to prevent flotation and lateral movement using a combination of mechanical earth anchors, log embedment into the channel and banks, and log placement against large trees adjacent to the stream channel. Some logs will be anchored by securing them with high-strength steel cable that is attached to mechanical earth anchors installed several feet below ground. Other logs will be anchored in place by partially embedding them into the channel and bank substrate far enough to overcome vertical and lateral forces. Some logs will be anchored by placing them against partially embedded logs and large trees adjacent to the stream channel and by securing one end using mechanical earth anchors.

All proposed modifications to the stream channel are for improving habitat conditions. No side channels exist within the project reach. Sound Transit will maintain the altered stream channel for a period of 10 years following construction to ensure the flood carrying capacity is not diminished. All maintenance will be completed in accordance with the Critical Areas Report for this Project and Sound Transit's approved maintenance program.

The project reach of Coal Creek is mapped as "Zone A" (no base flood elevations determined) on the most recent Flood Insurance Rate Map (FIRM) published by the Federal Emergency Management Agency (FEMA 1995). This same designation applies in recent FIRM updates produced by FEMA and King County that are undergoing review by FEMA before official adoption in the next few years (FEMA undated). Although the regulatory base flood elevation (i.e., the water surface elevation corresponding to the 100-year recurrence interval flow) of



the creek is not established through the project area, it is clear the Project will occur within the floodplain, and thus is subject to the “no rise” requirement in Section 20.25H.180 (development in the area of special flood hazard) of the City’s Land Use Code.

The City’s Land Use Code, specifically Section 20.25H.180, requires proponents of a project located within a regulatory floodway to demonstrate the flood-carrying capacity of the floodway will not be diminished, and that the regulatory base flood elevation in the vicinity of the project will not increase. Hydraulic modeling of existing (pre-project) and proposed project conditions provides a basis to compare the 100-year flood water surface elevation changes through the project reach to assess whether and how this code requirement can be met by the Project. This memorandum summarizes the results of the hydraulic modeling, the predicted effects of the Project on the Coal Creek floodway, and demonstrates how the Project complies with Section 20.25H.180 of the City’s Land Use Code.

Methods of Analysis

The hydraulic effects of the Project were evaluated using a HEC-RAS hydraulic model. The Hydrologic Engineering Center - River Analysis System (HEC-RAS) software program was developed by the US Army Corps of Engineers (USACE) Hydrologic Engineering Center (HEC) as a flood-hazard mapping tool and is used nationwide for developing FIRMs. HEC-RAS is a one-dimensional water surface profile program that models steady and unsteady, gradually varied flow. The computational procedure of a steady-state HEC-RAS model is based on solving the energy equation and energy losses between sequential topographical cross sections of the stream channel and floodplain along the profile of the stream channel (USACE 2009).

Herrera utilized a HEC-RAS hydraulic model previously developed by Northwest Hydraulic Consultants (NHC) for the lower 1.5 miles of Coal Creek, and updated the upstream cross sections of the model near the project site. The extent of the updated model domain in relation to the I-405 culvert, project area, and nearest residential development is shown in Attachment A. The new cross sections incorporated in the model for the Project are labeled in Attachment A. The purpose of updating the model geometry was to:

1. Reflect current channel and floodplain conditions by using new topographic survey data collected in October 2014.
2. Increase the density of cross sections to provide higher resolution in, and upstream of, the project area.

Flow rates used in the model were obtained from Table 3-1 of the Coal Creek Stabilization Program Final Environmental Impact Statement Volume 2 Technical Appendix A assuming the specified location of “Upstream of I-405” (Tetra Tech/KCM 2006). The 100-year recurrence interval flow of 565 cubic feet per second (cfs) was used to evaluate the Project for compliance with the City’s Land Use Code. Comparing model results for existing (pre-project) versus proposed project conditions allows for determination of whether the Project satisfies the City’s Land Use Code requirements.

The updated hydraulic model represented the existing (pre-project) conditions. Herrera used the updated existing conditions model to develop a proposed project conditions model by adding hydraulic roughness and flow blockages in the model cross sections to reflect the

proposed placement of LWD in the Coal Creek channel and floodplain. Multiple flow blockages were applied to specific cross sections in the project area using the obstructed area method in HEC-RAS. The dimensionless Manning's roughness ("n"-value) was also increased around the proposed flow blockages from 0.04 (gravel channel) to 0.15 to represent a dense placement of LWD.

Results

Results of the updated hydraulic analyses are provided in Attachments B through E. The project area is located between model cross sections 5267 (downstream end) and 5781 (upstream end) in the hydraulic model, with the I-405 culvert located between cross sections 4393 (downstream end) and 4897 (upstream end), and the Woodsong Condominiums residential property located upstream of cross section 6258 (approximately 500 feet upstream of the project site). Attachment B provides the simulated existing (pre-project) conditions water surface elevation profile upstream of the I-405 culvert for the 2-year, 10-year, and 100-year recurrence interval flood flows. This profile shows the relative hydraulic effects of the I-405 culvert at sequentially higher flood flows. The project site is not affected by this culvert during the estimated 2-year or 10-year flood discharges, but it is fully backwatered due to the I-405 culvert during the 100-year flood flow of 565 cfs. The water surface elevation profile also shows that the nearest upstream residential property (Woodsong Condominiums) is located upstream of the 100-year flood flow backwater caused by the I-405 culvert. The 100-year backwater elevation due to the I-405 culvert is approximately 74.5 feet (NAVD88), whereas the lowest elevation of the Woodsong Condominiums area is approximately 82 feet.

Attachments C and D provide model results for water surface elevations, flow velocities, and energy gradients for existing conditions and proposed conditions, respectively. Attachment E provides model output for a direct comparison between existing conditions and proposed conditions. This data is summarized in Table 1 for selected model cross sections to show the simulated change in water surface elevations and flow velocities during the 100-year flood flow due to the proposed project with references to the I-405 culvert, project area, and upstream residential property. The data in Table 1 is presented from upstream to downstream.

Significant landmarks and hydraulic changes that are estimated to occur between existing and proposed conditions are highlighted as bold in Table 1. Positive differences in Table 1 indicate an increase over existing conditions due to the Project for the hydraulic parameter, and negative differences indicate a decrease from existing conditions for the hydraulic parameter. The zone in which there is a constant water surface elevation of 74.49 feet (due to the backwater from the I-405 culvert) demonstrates no change in water surface elevation compared to existing conditions due to the Project. A slight increase in the 100-year water surface elevation of 0.01 to 0.03 feet is anticipated at the upstream end of the project site where the water surface profile transitions from the constant backwater elevation to a profile following the valley gradient. This transition is also shown in Attachment B. Water surface elevation increases ranging from 0.03 to 0.04 feet are estimated to extend approximately 250 feet upstream of the Project (cross section 5840 to cross section 6021). No water surface elevation change is indicated in the model output upstream of cross section 6021, so the

maximum extent of the hydraulic effects is estimated to be approximately 250 feet downstream of the nearest residential development. All of the minor hydraulic effects are confined to the Coal Creek Natural Area.

Table 1. Modeled Peak Water Surface Elevations for the 100-Year Flood Under Existing and Proposed Conditions.						
HEC-RAS Model Cross Section	Existing Water Surface Elevation (feet)	Post-Project Water Surface Elevation (feet)	Water Surface Difference (feet)	Existing Flow Velocity (feet/sec)	Post-Project Flow Velocity (feet/sec)	Velocity Difference (feet/sec)
Upstream Extent of Model						
7602.644	95.01	95.01	0.00	8.28	8.28	0.00
7034.648	86.56	86.56	0.00	7.78	7.78	0.00
6772.943	82.74	82.74	0.00	8.25	8.25	0.00
6513.829	78.03	78.03	0.00	6.25	6.25	0.00
6386.04*	77.56	77.56	0.00	4.86	4.86	0.00
Start of Residential Area						
6258.266	76.90	76.90	0.00	4.27	4.27	0.00
6140.08*	75.71	75.71	0.00	4.83	4.83	0.00
6021.9	74.57	74.61	0.04	4.83	4.76	-0.07
5960.99*	74.59	74.62	0.03	2.43	2.41	-0.02
5900.08	74.55	74.59	0.04	1.99	1.96	-0.03
5840.97*	74.52	74.56	0.04	1.61	1.59	-0.02
Upstream Extent of Project						
5781.861	74.51	74.54	0.03	1.17	0.75	-0.42
5730.79*	74.50	74.52	0.02	1.19	0.85	-0.34
5679.72*	74.49	74.50	0.01	0.98	0.75	-0.23
5628.661	74.49	74.49	0.00	0.68	0.43	-0.25
5520.611	74.49	74.49	0.00	0.62	0.62	0.00
5414.208	74.48	74.48	0.00	0.47	0.47	0.00
5319.381	74.48	74.48	0.00	0.47	0.35	-0.12
5267.39*	74.48	74.48	0.00	0.47	0.38	-0.09
Downstream Extent of Project						
5241.396	74.48	74.48	0.00	0.34	0.34	0.00
5150.487	74.48	74.48	0.00	0.19	0.19	0.00
5067.673	74.48	74.48	0.00	0.22	0.22	0.00
5022.706	74.48	74.48	0.00	0.22	0.22	0.00
4975.96	74.48	74.48	0.00	0.20	0.20	0.00
4933.66	74.48	74.48	0.00	0.24	0.24	0.00
I-405 Culvert						

Table 1 also demonstrates that the average in-channel flow velocity for the 100-year flood will decrease in the project area in the same general extents as the water surface elevation changes. This average velocity decrease will slightly reduce the risk of channel incision,

general bank erosion, and avulsion of the left bank near the fish pond area. It is important to note that these predicted flow velocity decreases are “average” channel velocities; and it is anticipated that there will be minor local erosion near the LWD pieces; but in general, the erosive energy of the channel will decrease as a result of the Project.

Compliance with Land Use Code 20.25H.180

Section 20.25H.180 of the City of Bellevue Land Use Code restricts development in the regulated floodplain and floodway to protect surrounding property and infrastructure based on requirements established by FEMA. The code states that no use, development, or activity may occur in an area of special flood hazard that results in a rise in the Base Flood Elevation (BFE) established by FEMA. While the majority of the requirements are applicable to residential development or other infrastructure components in the floodway, Articles C.4b, C.5a, C.7e.ii, and D.5 include requirements for encroachments applicable to potential changes in BFEs and compensatory flood storage. However, the project area is in a special flood hazard “Zone A” where no BFEs have been established by FEMA. Despite the Project being in a Zone A area, its design was modified several times; and a detailed analysis was conducted 1) to keep any rise in the 100-year water surface elevation as close to zero as possible, 2) not to increase other existing flood hazards, and 3) to verify that the Project complies with the intent of Section 20.25H.180 and FEMA guidelines to protect upstream and downstream properties and infrastructure even though the code applies specifically to flood zones with established BFEs.

The design procedure for the Coal Creek Stream Enhancement Project followed the FEMA *Region 10 National Flood Insurance Program (NFIP) Guidebook*, specifically Appendix E in that guidebook as it pertains to fish enhancement structures in a floodway, which states that water surface rises are likely in relation to fish habitat restoration work and that attempts should be made to keep the 100-year water surface rise as close to zero as possible. Three design iterations were made in consultation with the City of Bellevue to minimize LWD encroachment in the Coal Creek channel and associated effects on water surface elevations while still maintaining the required functions as part of Sound Transit’s restoration goals and mitigation requirements. This approach also complies with the intent of Article D.5 in Section 20.25H.180 of the City of Bellevue Land Use Code, which states that projects may be allowed in the area of special flood hazard and may increase the BFE provided that the project produces measurable benefits, such as decreased erosion, peak flow reduction, improved water quality, and/or improved aquatic habitat and does not threaten existing properties or structures. The model results documented in this memorandum indicate that the Project will result in lower flow velocities and less erosion while significantly improving existing aquatic habitat, without adverse effects on occupied structures or other infrastructure or properties upstream or downstream of the project. Furthermore, as a mitigation and habitat enhancement project, one of the project objectives is to minimize disturbances to the abundant native vegetation in the floodplain; therefore, the design iterations described above were completed to minimize water surface rises so that requirements to provide compensatory storage (e.g., removing fill from the floodplain to

offset the water surface rises and maintain existing flood storage capacity within the project area) would not be necessary.

As for effects on flood storage, the minor water surface rise predicted by the model during the 100-year flood as a result of the Project is located entirely within a very large ponded area that is hydraulically controlled by the flow control structure located downstream of the project site at the I-405 culvert entrance. Depths in this ponded area range from 15 to 20 feet during large flood flows such as the 100-year flood. The modeling results show that no rise in water surface elevations or flow velocities is expected near the City's flow control structure, which controls the timing and magnitudes of downstream delivery of floodwater; and, therefore, the project should not alter existing flooding conditions downstream of I-405. The intent of the code to maintain existing (pre-project) flood storage and not to increase existing flood hazards is thus met. In fact, the volume of water stored in the project area during a 100-year flood event is estimated to increase by approximately 2,500 cubic feet due to the slight increase in peak water surface elevation, and that is equal to the volume of wood to be placed in the floodplain. This indicates that there will be no change in flood water storage in the project area, and thus the creation of compensatory storage is not required.

Conclusions

Based upon hydraulic modeling, it is anticipated that the Project will result in a minor increase in water surface elevations and a minor decrease in flow velocities in the project area during flood events. These minor hydraulic changes will extend approximately 250 feet upstream of the project site during a 100-year flood event, but that extent would still be 250 feet downstream of the nearest residential development. The project will also not alter existing flood conditions downstream of the project area. The hydraulic modeling results suggest the Project's effects will be confined to the Coal Creek Natural Area and satisfy the requirements and intent of Section 20.25H.180 of the City of Bellevue Land Use Code. In sum, the Project will not diminish the flood-carrying capacity of the floodway or adversely impact any properties or infrastructure outside of the immediate project area.

References

- FEMA. 1995. Flood Insurance Rate Map. King County, Washington and Incorporated Areas. Panel 658 of 1725, Map Number 53033C0658 F. Federal Emergency Management Agency.
- FEMA. 2009. NFIP Floodplain Management Guidebook, 5th Edition. Produced by Federal Emergency Management Agency - Region 10, Bothell, Washington.
- Tetra Tech/KCM. Coal Creek Stabilization Program Final Environmental Impact Statement. Prepared for City of Bellevue by Tetra Tech/KCM, Inc., Seattle, Washington. June 2006.
- USACE. 2009. US Army Corps of Engineers, Hydrologic Engineering Center, HEC-RAS 4.1 User's Manual.

ATTACHMENT A

Updated Model Domain

Note:

Some pages in this document have been purposely skipped or blank pages inserted so that this document will copy correctly when duplexed.

Updated Model Domain

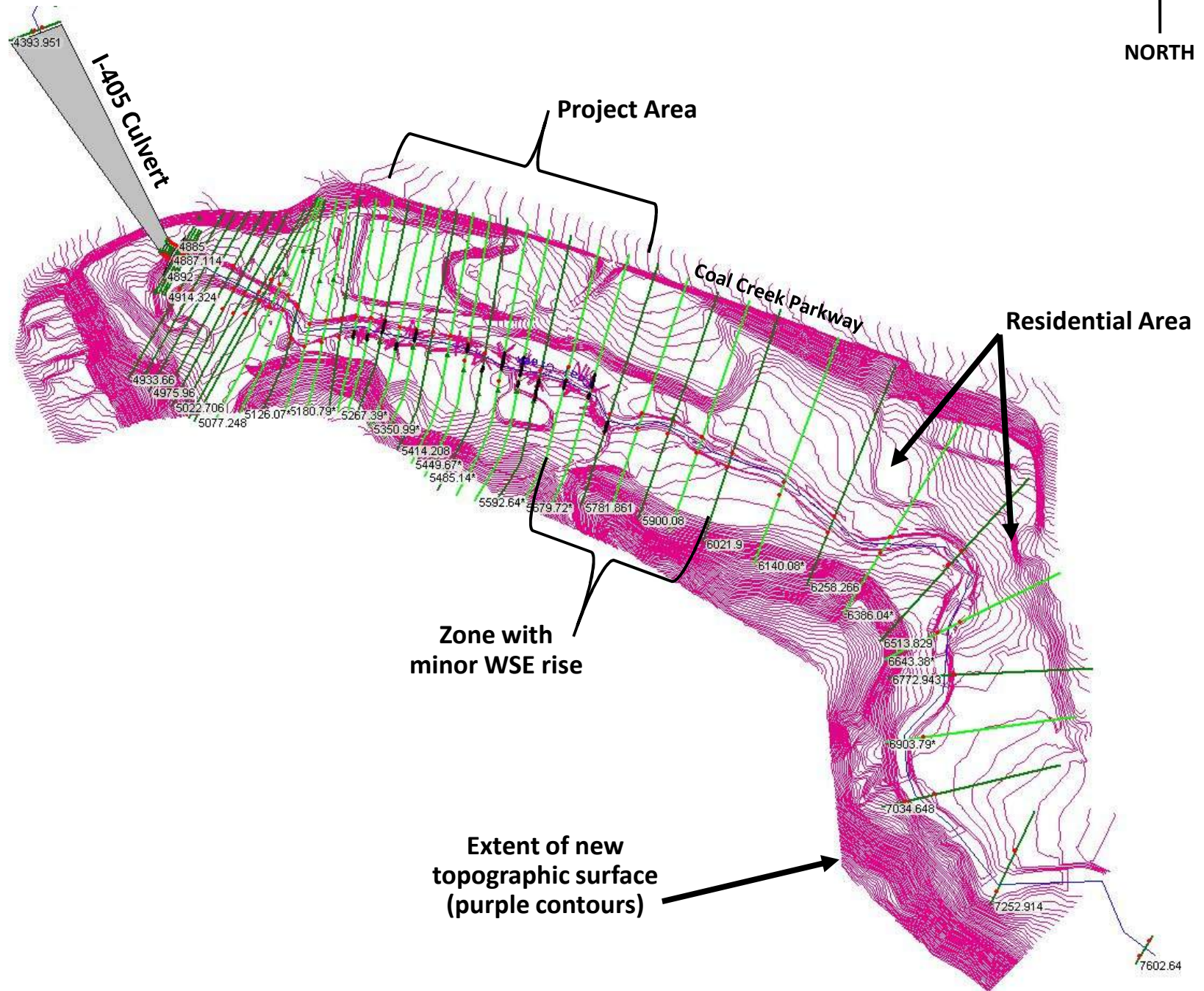

This page intentionally left blank

ATTACHMENT B

2-Year, 10-Year, and 100-Year WSE Profile

2-year, 10-year, and 100-year WSE Profile

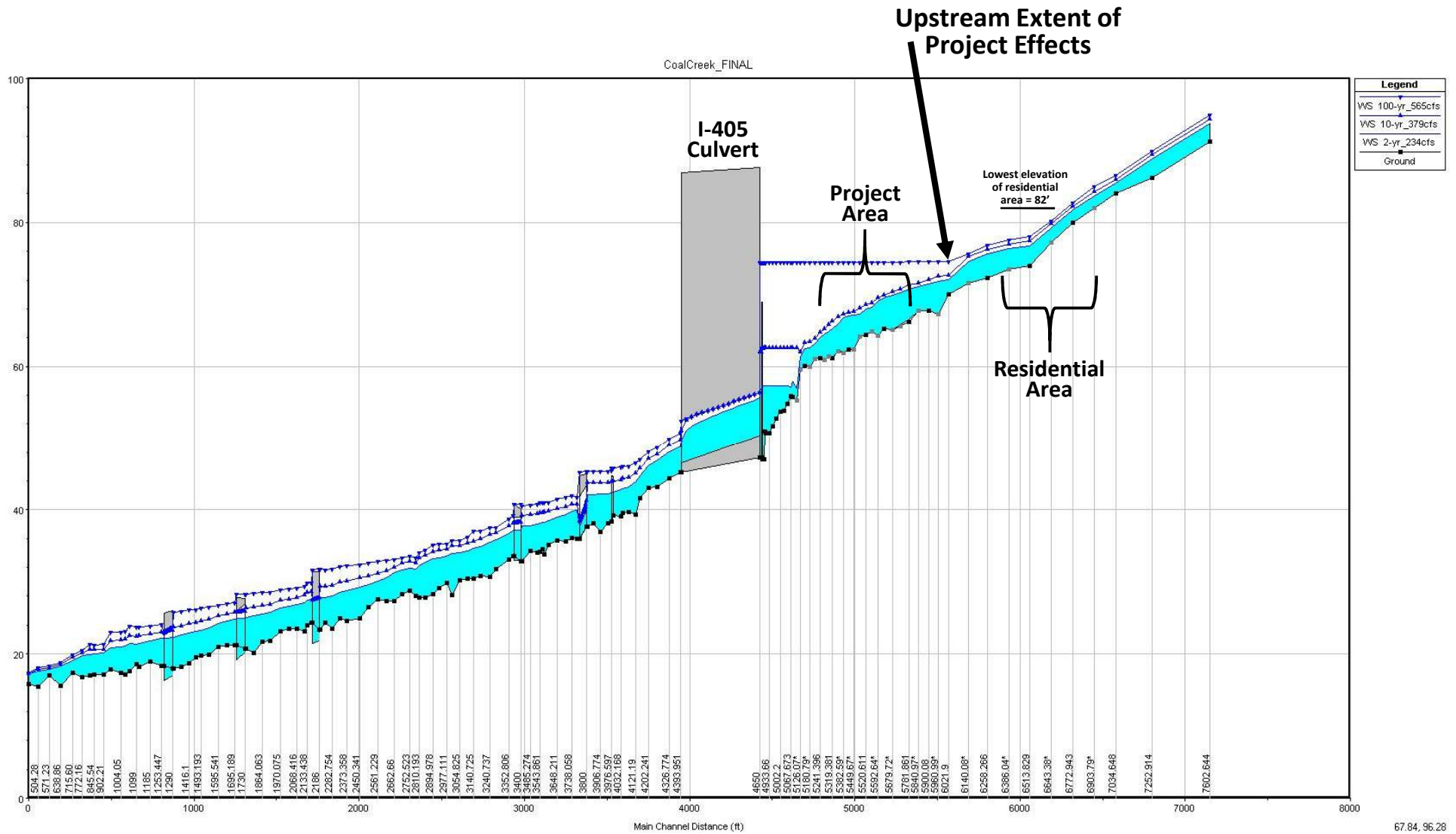

This page intentionally left blank

ATTACHMENT C

HEC-RAS Plan: HEC Exist 1 Locations:
User Defined

River	Reach	River Sta	Profile	Q Total (cfs)	Min Ch El (ft)	W.S. Elev (ft)	Crit W.S. (ft)	E.G. Elev (ft)	E.G. Slope (ft/ft)	Vel Chnl (ft/s)	Flow Area (sq ft)	Top Width (ft)	Froude # Chl
Coal Creek	Coal Creek	7602.644	Average Annual	14.80	91.29	92.12	92.05	92.26	0.020197	3.04	4.87	11.02	0.81
Coal Creek	Coal Creek	7602.644	Annual_98cfs	98.00	91.29	93.04	92.97	93.48	0.020606	5.33	18.40	18.06	0.93
Coal Creek	Coal Creek	7602.644	1.25-yr_170cfs	170.00	91.29	93.45	93.45	94.09	0.022731	6.43	26.43	20.97	1.01
Coal Creek	Coal Creek	7602.644	2-yr_234cfs	234.00	91.29	93.79	93.79	94.53	0.021807	6.90	33.90	23.43	1.01
Coal Creek	Coal Creek	7602.644	5-yr_321cfs-	321.00	91.29	94.17	94.17	95.02	0.020843	7.38	43.50	26.26	1.01
Coal Creek	Coal Creek	7602.644	10-yr_379cfs	379.00	91.29	94.40	94.40	95.30	0.020341	7.62	49.72	28.06	1.01
Coal Creek	Coal Creek	7602.644	25-yr_453cfs	453.00	91.29	94.67	94.67	95.63	0.019812	7.88	57.47	30.24	1.01
Coal Creek	Coal Creek	7602.644	100-yr_565cfs	565.00	91.29	95.01	95.01	96.07	0.018853	8.28	68.34	33.10	1.00
Coal Creek	Coal Creek	7602.644	500-yr_698cfs	698.00	91.29	95.36	95.36	96.55	0.018011	8.73	80.59	36.10	1.00
Coal Creek	Coal Creek	7252.914	Average Annual	14.80	86.23	87.00		87.09	0.011249	2.37	6.24	13.22	0.61
Coal Creek	Coal Creek	7252.914	Annual_98cfs	98.00	86.23	88.03		88.26	0.011065	3.88	25.23	25.15	0.68
Coal Creek	Coal Creek	7252.914	1.25-yr_170cfs	170.00	86.23	88.50	88.17	88.80	0.010596	4.38	38.84	31.32	0.69
Coal Creek	Coal Creek	7252.914	2-yr_234cfs	234.00	86.23	88.83	88.45	89.18	0.010220	4.70	49.74	35.03	0.70
Coal Creek	Coal Creek	7252.914	5-yr_321cfs-	321.00	86.23	89.21	88.77	89.60	0.009783	5.03	63.80	39.29	0.70
Coal Creek	Coal Creek	7252.914	10-yr_379cfs	379.00	86.23	89.41	88.97	89.84	0.009827	5.28	71.80	41.28	0.71
Coal Creek	Coal Creek	7252.914	25-yr_453cfs	453.00	86.23	89.63	89.17	90.12	0.009789	5.57	81.32	42.95	0.71
Coal Creek	Coal Creek	7252.914	100-yr_565cfs	565.00	86.23	89.94	89.47	90.49	0.009834	5.97	94.67	45.20	0.73
Coal Creek	Coal Creek	7252.914	500-yr_698cfs	698.00	86.23	90.25	89.77	90.89	0.009938	6.38	109.38	47.56	0.74
Coal Creek	Coal Creek	7034.648	Average Annual	14.80	84.00	84.34		84.40	0.013364	2.01	7.37	23.00	0.62
Coal Creek	Coal Creek	7034.648	Annual_98cfs	98.00	84.00	84.94	84.84	85.24	0.017694	4.40	22.29	26.24	0.84
Coal Creek	Coal Creek	7034.648	1.25-yr_170cfs	170.00	84.00	85.27	85.19	85.73	0.019326	5.48	31.01	27.91	0.92
Coal Creek	Coal Creek	7034.648	2-yr_234cfs	234.00	84.00	85.57	85.46	86.10	0.020230	6.20	37.74	29.15	0.96
Coal Creek	Coal Creek	7034.648	5-yr_321cfs-	321.00	84.00	85.78	85.78	86.54	0.021172	6.98	45.96	30.64	1.01
Coal Creek	Coal Creek	7034.648	10-yr_379cfs	379.00	84.00	85.97	85.97	86.80	0.020653	7.30	51.94	31.80	1.01
Coal Creek	Coal Creek	7034.648	25-yr_453cfs	453.00	84.00	86.22	86.22	87.10	0.020164	7.53	60.16	34.50	1.00
Coal Creek	Coal Creek	7034.648	100-yr_565cfs	565.00	84.00	86.56	86.56	87.50	0.019702	7.78	72.58	38.92	1.00
Coal Creek	Coal Creek	7034.648	500-yr_698cfs	698.00	84.00	86.90	86.90	87.91	0.019340	8.05	86.66	43.55	1.01
Coal Creek	Coal Creek	6903.79*	Average Annual	14.80	82.00	82.31	82.25	82.38	0.017940	2.17	6.83	23.70	0.71
Coal Creek	Coal Creek	6903.79*	Annual_98cfs	98.00	82.00	83.01	82.83	83.25	0.013086	3.88	25.25	28.67	0.73
Coal Creek	Coal Creek	6903.79*	1.25-yr_170cfs	170.00	82.00	83.42		83.74	0.011928	4.52	37.60	31.57	0.73
Coal Creek	Coal Creek	6903.79*	2-yr_234cfs	234.00	82.00	83.73		84.11	0.011211	4.90	47.72	33.80	0.73
Coal Creek	Coal Creek	6903.79*	5-yr_321cfs-	321.00	82.00	84.10	83.72	84.54	0.010459	5.28	60.78	36.49	0.72
Coal Creek	Coal Creek	6903.79*	10-yr_379cfs	379.00	82.00	84.34	83.90	84.80	0.009845	5.44	69.68	38.21	0.71
Coal Creek	Coal Creek	6903.79*	25-yr_453cfs	453.00	82.00	84.63	84.12	85.12	0.009166	5.59	80.97	40.29	0.70
Coal Creek	Coal Creek	6903.79*	100-yr_565cfs	565.00	82.00	84.96	84.41	85.51	0.009156	5.97	94.68	42.69	0.71
Coal Creek	Coal Creek	6903.79*	500-yr_698cfs	698.00	82.00	86.10	84.73	86.44	0.004055	4.70	148.55	54.40	0.49
Coal Creek	Coal Creek	6772.943	Average Annual	14.80	80.00	80.40		80.47	0.012065	2.09	7.07	19.16	0.61
Coal Creek	Coal Creek	6772.943	Annual_98cfs	98.00	80.00	81.12		81.42	0.014790	4.35	22.52	23.46	0.78
Coal Creek	Coal Creek	6772.943	1.25-yr_170cfs	170.00	80.00	81.51		81.95	0.015660	5.31	32.04	25.78	0.84
Coal Creek	Coal Creek	6772.943	2-yr_234cfs	234.00	80.00	81.79	81.64	82.34	0.016218	5.93	39.44	27.47	0.87
Coal Creek	Coal Creek	6772.943	5-yr_321cfs-	321.00	80.00	82.10	81.98	82.79	0.017162	6.65	48.24	29.46	0.92
Coal Creek	Coal Creek	6772.943	10-yr_379cfs	379.00	80.00	82.26	82.19	83.05	0.018336	7.14	53.04	30.57	0.96
Coal Creek	Coal Creek	6772.943	25-yr_453cfs	453.00	80.00	82.43	82.43	83.36	0.019910	7.75	58.49	32.00	1.01
Coal Creek	Coal Creek	6772.943	100-yr_565cfs	565.00	80.00	82.74	82.74	83.80	0.018810	8.25	69.13	36.44	1.00
Coal Creek	Coal Creek	6772.943	500-yr_698cfs	698.00	80.00	85.95		86.13	0.001204	3.52	255.00	76.80	0.29
Coal Creek	Coal Creek	6643.38*	Average Annual	14.80	77.19	77.76	77.76	77.92	0.036845	3.22	4.60	15.05	1.03
Coal Creek	Coal Creek	6643.38*	Annual_98cfs	98.00	77.19	78.51	78.51	78.94	0.025612	5.28	18.55	21.86	1.01
Coal Creek	Coal Creek	6643.38*	1.25-yr_170cfs	170.00	77.19	79.01	78.91	79.48	0.023324	6.09	27.90	24.67	1.01
Coal Creek	Coal Creek	6643.38*	2-yr_234cfs	234.00	77.19	79.20	79.20	79.88	0.022287	6.58	35.54	26.98	1.01
Coal Creek	Coal Creek	6643.38*	5-yr_321cfs-	321.00	77.19	79.63	79.63	80.31	0.021390	6.58	49.20	40.80	1.00
Coal Creek	Coal Creek	6643.38*	10-yr_379cfs	379.00	77.19	79.89	79.89	80.52	0.020076	6.43	62.16	62.62	0.97
Coal Creek	Coal Creek	6643.38*	25-yr_453cfs	453.00	77.19	80.06	80.06	80.75	0.019279	6.73	73.74	68.03	0.96
Coal Creek	Coal Creek	6643.38*	100-yr_565cfs	565.00	77.19	80.19	80.32	81.09	0.022634	7.69	82.52	71.27	1.06
Coal Creek	Coal Creek	6643.38*	500-yr_698cfs	698.00	77.19	86.02		86.05	0.000118	1.53	854.23	198.31	0.10
Coal Creek	Coal Creek	6513.829	Average Annual	14.80	74.01	74.89	74.61	74.94	0.005676	1.80	8.21	15.76	0.44
Coal Creek	Coal Creek	6513.829	Annual_98cfs	98.00	74.01	75.80	75.44	76.00	0.008477	3.56	27.53	25.46	0.60
Coal Creek	Coal Creek	6513.829	1.25-yr_170cfs	170.00	74.01	76.35	75.83	76.61	0.006960	4.07	41.73	26.84	0.58
Coal Creek	Coal Creek	6513.829	2-yr_234cfs	234.00	74.01	76.77	76.10	77.07	0.006234	4.40	53.17	27.75	0.56
Coal Creek	Coal Creek	6513.829	5-yr_321cfs-	321.00	74.01	77.21	76.43	77.58	0.006132	4.88	65.71	28.66	0.57
Coal Creek	Coal Creek	6513.829	10-yr_379cfs	379.00	74.01	77.44	76.63	77.87	0.006432	5.24	72.33	29.32	0.59
Coal Creek	Coal Creek	6513.829	25-yr_453cfs	453.00	74.01	77.70	76.88	78.20	0.006876	5.66	79.99	30.25	0.61
Coal Creek	Coal Creek	6513.829	100-yr_565cfs	565.00	74.01	78.03	77.20	78.64	0.007567	6.25	90.40	31.59	0.65
Coal Creek	Coal Creek	6513.829	500-yr_698cfs	698.00	74.01	86.01		86.04	0.000070	1.42	947.95	202.24	0.08
Coal Creek	Coal Creek	6386.04*	Average Annual	14.80	73.46	74.10		74.15	0.006878	1.64	9.04	23.23	0.46
Coal Creek	Coal Creek	6386.04*	Annual_98cfs	98.00	73.46	75.19		75.30	0.003543	2.65	37.05	27.68	0.40
Coal Creek	Coal Creek	6386.04*	1.25-yr_170cfs	170.00	73.46	75.89		76.03	0.002825	2.97	57.23	29.98	0.38
Coal Creek	Coal Creek	6386.04*	2-yr_234cfs	234.00	73.46	76.34		76.51	0.002813	3.29	71.11	31.68	0.39
Coal Creek	Coal Creek	6386.04*	5-yr_321cfs-	321.00	73.46	76.76		76.98	0.003221	3.78	87.44	50.40	0.42
Coal Creek	Coal Creek	6386.04*	10-yr_379cfs	379.00	73.46	76.98		77.24	0.003345	4.07	100.96	66.39	0.44
Coal Creek	Coal Creek	6386.04*	25-yr_453cfs	453.00	73.46	77.23		77.53	0.003484	4.41	118.17	72.38	0.45
Coal Creek	Coal Creek	6386.04*	100-yr_565cfs	565.00	73.46	77.56		77.91	0.003681	4.86	143.44	81.96	0.47
Coal Creek	Coal Creek	6386.04*	500-yr_698cfs	698.00	73.46	86.02		86.03	0.000032	1.05	1520.42	253.72	0.05
Coal Creek	Coal Creek	6258.266	Average Annual	14.80	72.31	73.05		73.12	0.009364	2.17	6.82	14.38	0.56
Coal Creek	Coal Creek	6258.266	Annual_98cfs	98.00	72.31	74.22		74.56	0.011050	2.99	32.81	22.89	0.44
Coal Creek	Coal Creek	6258.266	1.25-yr_170cfs	170.00	72.31	75.23		75.38	0.011495	3.18	54.78	38.88	0.41
Coal Creek	Coal Creek	6258.266	2-yr_234cfs	234.00	72.31	75.71		75.87	0.011315	3.28	80.00	62.78	0.40
Coal Creek	Coal Creek	6258.266	5-yr_321cfs-	321.00	72.31	76.10		76.28	0.010868	3.60	106.44	73.90	0.40
Coal Creek	Coal Creek	6258.266	10-yr_379cfs	379.00	72.31	76.31		76.52	0.010763	3.79	123.45	81.64	0.41
Coal Creek	Coal Creek	6258.266	25-yr_453cfs	453.00	72.31	76.56		76.78	0.010641	4.00	144.98	90.52	0.41
Coal Creek	Coal Creek	6258.266	100-yr_565cfs	565.00	72.31	76.90		77.13	0.010470	4.27	177.05	102.22	0.42
Coal Creek	Coal Creek	6258.266	500-yr_698cfs	698.00	72.31	86.02		86.02	0.000021	0.46	2468.17	326.01	0.02
Coal Creek	Coal Creek	6140.08*	Average Annual	14.80	71.55	72.17		72.21	0.006201	1.62	9.15	18.88	0.41
Coal Creek	Coal Creek	6140.08*	Annual_98cfs	98.00	71.55	73.46		73.57	0.006490	2.70	36.32	23.41	0.38
Coal Creek	Coal Creek	6140.08*	1.25-yr_170cfs	170.00	71.55	74.16		74.31	0.007348	3.17	54.13	32.32	0.39

HEC-RAS Plan: HECexist1 Locations: User Defined (Continued)

River	Reach	River Sta	Profile	Q Total (cfs)	Min Ch El (ft)	W.S. Elev (ft)	Crit W.S. (ft)	E.G. Elev (ft)	E.G. Slope (ft/ft)	Vel Chnl (ft/s)	Flow Area (sq ft)	Top Width (ft)	Froude # Chl
Coal Creek	Coal Creek	6140.08*	2-yr_234cfs	234.00	71.55	74.59		74.78	0.007611	3.52	74.16	66.60	0.40
Coal Creek	Coal Creek	6140.08*	5-yr_321cfs-	321.00	71.55	75.02		75.23	0.007341	3.86	106.83	85.13	0.40
Coal Creek	Coal Creek	6140.08*	10-yr_379cfs	379.00	71.55	75.27	73.95	75.49	0.007103	4.01	129.39	95.99	0.40
Coal Creek	Coal Creek	6140.08*	25-yr_453cfs	453.00	71.55	75.53	74.26	75.77	0.006984	4.21	156.58	107.65	0.40
Coal Creek	Coal Creek	6140.08*	100-yr_565cfs	565.00	71.55	75.71		76.01	0.008624	4.83	175.74	115.16	0.45
Coal Creek	Coal Creek	6140.08*	500-yr_698cfs	698.00	71.55	86.02		86.02	0.000011	0.42	3114.95	356.15	0.02
Coal Creek	Coal Creek	6021.9	Average Annual	14.80	69.97	70.57	70.57	70.75	0.034144	3.40	4.35	12.41	1.01
Coal Creek	Coal Creek	6021.9	Annual_98cfs	98.00	69.97	71.39	71.39	71.82	0.057980	5.26	18.61	22.11	1.01
Coal Creek	Coal Creek	6021.9	1.25-yr_170cfs	170.00	69.97	71.77	71.77	72.37	0.058977	6.18	27.50	23.72	1.01
Coal Creek	Coal Creek	6021.9	2-yr_234cfs	234.00	69.97	72.06	72.06	72.78	0.058978	6.78	34.50	24.67	1.01
Coal Creek	Coal Creek	6021.9	5-yr_321cfs-	321.00	69.97	72.41	72.41	73.26	0.059934	7.40	43.40	26.06	1.01
Coal Creek	Coal Creek	6021.9	10-yr_379cfs	379.00	69.97	72.63	72.63	73.55	0.060648	7.71	49.18	27.09	1.01
Coal Creek	Coal Creek	6021.9	25-yr_453cfs	453.00	69.97	72.97	72.89	73.89	0.055879	7.73	58.71	31.21	0.96
Coal Creek	Coal Creek	6021.9	100-yr_565cfs	565.00	69.97	74.57		74.90	0.010139	4.83	155.80	109.69	0.45
Coal Creek	Coal Creek	6021.9	500-yr_698cfs	698.00	69.97	86.02		86.02	0.000006	0.31	3805.83	389.39	0.01
Coal Creek	Coal Creek	5960.99*	Average Annual	14.80	67.30	68.91	68.01	68.92	0.000642	0.85	17.39	19.93	0.16
Coal Creek	Coal Creek	5960.99*	Annual_98cfs	98.00	67.30	70.30	68.94	70.36	0.001874	1.94	50.45	26.20	0.25
Coal Creek	Coal Creek	5960.99*	1.25-yr_170cfs	170.00	67.30	71.08	69.36	71.17	0.002439	2.37	71.62	28.41	0.26
Coal Creek	Coal Creek	5960.99*	2-yr_234cfs	234.00	67.30	71.63	69.66	71.74	0.002854	2.67	87.69	29.98	0.27
Coal Creek	Coal Creek	5960.99*	5-yr_321cfs-	321.00	67.30	72.23	70.02	72.37	0.003496	3.02	106.40	32.14	0.29
Coal Creek	Coal Creek	5960.99*	10-yr_379cfs	379.00	67.30	72.55	70.23	72.71	0.003816	3.24	119.05	57.40	0.30
Coal Creek	Coal Creek	5960.99*	25-yr_453cfs	453.00	67.30	72.88		73.07	0.003980	3.50	144.08	92.95	0.31
Coal Creek	Coal Creek	5960.99*	100-yr_565cfs	565.00	67.30	74.59		74.67	0.001180	2.43	359.82	154.12	0.18
Coal Creek	Coal Creek	5960.99*	500-yr_698cfs	698.00	67.30	86.02		86.02	0.000009	0.46	3020.66	402.14	0.02
Coal Creek	Coal Creek	5900.08	Average Annual	14.80	67.79	68.81	68.37	68.84	0.003195	1.54	9.59	14.89	0.34
Coal Creek	Coal Creek	5900.08	Annual_98cfs	98.00	67.79	69.97	69.27	70.14	0.007878	3.31	29.57	19.63	0.48
Coal Creek	Coal Creek	5900.08	1.25-yr_170cfs	170.00	67.79	70.64	69.76	70.88	0.011003	3.88	43.84	25.56	0.50
Coal Creek	Coal Creek	5900.08	2-yr_234cfs	234.00	67.79	71.13	70.12	71.40	0.012596	4.21	55.64	37.70	0.50
Coal Creek	Coal Creek	5900.08	5-yr_321cfs-	321.00	67.79	71.65	70.55	71.98	0.013529	4.61	70.25	56.79	0.51
Coal Creek	Coal Creek	5900.08	10-yr_379cfs	379.00	67.79	71.92	70.79	72.29	0.013726	4.88	81.03	74.77	0.52
Coal Creek	Coal Creek	5900.08	25-yr_453cfs	453.00	67.79	72.24	71.08	72.64	0.013464	5.13	100.89	106.51	0.52
Coal Creek	Coal Creek	5900.08	100-yr_565cfs	565.00	67.79	74.55	71.47	74.59	0.000954	1.99	495.75	189.76	0.15
Coal Creek	Coal Creek	5900.08	500-yr_698cfs	698.00	67.79	86.02	71.93	86.02	0.000008	0.38	3049.44	261.57	0.02
Coal Creek	Coal Creek	5840.97*	Average Annual	14.80	67.69	68.22	68.22	68.38	0.035124	3.20	4.62	14.69	1.01
Coal Creek	Coal Creek	5840.97*	Annual_98cfs	98.00	67.69	69.16		69.41	0.021623	4.02	24.38	23.52	0.70
Coal Creek	Coal Creek	5840.97*	1.25-yr_170cfs	170.00	67.69	69.73		70.03	0.018754	4.46	38.11	25.14	0.64
Coal Creek	Coal Creek	5840.97*	2-yr_234cfs	234.00	67.69	70.12		70.49	0.019193	4.84	48.39	26.63	0.63
Coal Creek	Coal Creek	5840.97*	5-yr_321cfs-	321.00	67.69	70.55		70.99	0.020882	5.34	60.12	28.96	0.65
Coal Creek	Coal Creek	5840.97*	10-yr_379cfs	379.00	67.69	70.75		71.26	0.022000	5.74	66.23	30.25	0.67
Coal Creek	Coal Creek	5840.97*	25-yr_453cfs	453.00	67.69	70.95	70.41	71.57	0.024473	6.31	73.14	43.65	0.71
Coal Creek	Coal Creek	5840.97*	100-yr_565cfs	565.00	67.69	74.52		74.55	0.000487	1.61	569.47	176.12	0.12
Coal Creek	Coal Creek	5840.97*	500-yr_698cfs	698.00	67.69	86.02		86.02	0.000006	0.37	2997.91	249.54	0.02
Coal Creek	Coal Creek	5781.861	Average Annual	14.80	66.22	67.08	66.93	67.18	0.012681	2.49	5.94	12.79	0.64
Coal Creek	Coal Creek	5781.861	Annual_98cfs	98.00	66.22	68.27		68.44	0.012487	3.33	29.45	24.12	0.53
Coal Creek	Coal Creek	5781.861	1.25-yr_170cfs	170.00	66.22	68.99		69.18	0.010660	3.51	49.70	44.62	0.47
Coal Creek	Coal Creek	5781.861	2-yr_234cfs	234.00	66.22	69.53		69.70	0.008581	3.45	75.65	51.80	0.41
Coal Creek	Coal Creek	5781.861	5-yr_321cfs-	321.00	66.22	70.03		70.20	0.007792	3.51	107.65	76.24	0.39
Coal Creek	Coal Creek	5781.861	10-yr_379cfs	379.00	66.22	70.29		70.45	0.007506	3.54	130.49	93.60	0.38
Coal Creek	Coal Creek	5781.861	25-yr_453cfs	453.00	66.22	70.56		70.72	0.007097	3.63	156.37	99.03	0.37
Coal Creek	Coal Creek	5781.861	100-yr_565cfs	565.00	66.22	74.51		74.52	0.000236	1.17	692.33	174.77	0.08
Coal Creek	Coal Creek	5781.861	500-yr_698cfs	698.00	66.22	86.02		86.02	0.000006	0.35	2989.74	234.76	0.01
Coal Creek	Coal Creek	5730.79*	Average Annual	14.80	65.54	66.30		66.42	0.017546	2.80	5.28	12.16	0.75
Coal Creek	Coal Creek	5730.79*	Annual_98cfs	98.00	65.54	67.82		67.94	0.007472	2.71	36.13	25.04	0.40
Coal Creek	Coal Creek	5730.79*	1.25-yr_170cfs	170.00	65.54	68.59		68.73	0.006887	3.02	56.26	27.43	0.37
Coal Creek	Coal Creek	5730.79*	2-yr_234cfs	234.00	65.54	69.14		69.30	0.006975	3.25	72.06	31.15	0.37
Coal Creek	Coal Creek	5730.79*	5-yr_321cfs-	321.00	65.54	69.59		69.80	0.007572	3.71	92.27	64.46	0.39
Coal Creek	Coal Creek	5730.79*	10-yr_379cfs	379.00	65.54	69.83		70.06	0.007552	3.91	110.82	81.66	0.39
Coal Creek	Coal Creek	5730.79*	25-yr_453cfs	453.00	65.54	70.10		70.34	0.007496	4.12	134.28	93.92	0.40
Coal Creek	Coal Creek	5730.79*	100-yr_565cfs	565.00	65.54	74.50		74.51	0.000206	1.19	729.17	173.14	0.08
Coal Creek	Coal Creek	5730.79*	500-yr_698cfs	698.00	65.54	86.02		86.02	0.000005	0.33	3453.03	300.55	0.01
Coal Creek	Coal Creek	5679.72*	Average Annual	14.80	65.06	66.10		66.12	0.002493	1.37	10.83	16.95	0.30
Coal Creek	Coal Creek	5679.72*	Annual_98cfs	98.00	65.06	67.54		67.62	0.005019	2.24	43.74	27.86	0.32
Coal Creek	Coal Creek	5679.72*	1.25-yr_170cfs	170.00	65.06	68.31		68.41	0.005318	2.53	67.24	34.30	0.31
Coal Creek	Coal Creek	5679.72*	2-yr_234cfs	234.00	65.06	68.87		68.98	0.005212	2.70	91.41	67.56	0.30
Coal Creek	Coal Creek	5679.72*	5-yr_321cfs-	321.00	65.06	69.33		69.46	0.005071	2.99	127.33	87.49	0.31
Coal Creek	Coal Creek	5679.72*	10-yr_379cfs	379.00	65.06	69.58		69.72	0.005071	3.16	150.70	102.40	0.31
Coal Creek	Coal Creek	5679.72*	25-yr_453cfs	453.00	65.06	69.85		70.01	0.005057	3.33	181.16	117.87	0.32
Coal Creek	Coal Creek	5679.72*	100-yr_565cfs	565.00	65.06	74.49		74.50	0.000141	0.98	925.02	193.90	0.06
Coal Creek	Coal Creek	5679.72*	500-yr_698cfs	698.00	65.06	86.02		86.02	0.000005	0.32	3775.08	329.75	0.01
Coal Creek	Coal Creek	5628.661	Average Annual	14.80	65.25	65.82		65.89	0.010407	2.07	7.15	16.73	0.56
Coal Creek	Coal Creek	5628.661	Annual_98cfs	98.00	65.25	67.16		67.30	0.007739	2.93	33.49	70.37	0.42
Coal Creek	Coal Creek	5628.661	1.25-yr_170cfs	170.00	65.25	67.88		68.06	0.009087	3.38	50.26	76.91	0.42
Coal Creek	Coal Creek	5628.661	2-yr_234cfs	234.00	65.25	68.40		68.60	0.010607	3.63	64.92	91.57	0.43
Coal Creek	Coal Creek	5628.661	5-yr_321cfs-	321.00	65.25	68.85		69.09	0.010701	4.00	90.90	125.02	0.44
Coal Creek	Coal Creek	5628.661	10-yr_379cfs	379.00	65.25	69.11		69.36	0.010071	4.14	109.40	129.20	0.43
Coal Creek	Coal Creek	5628.661	25-yr_453cfs	453.00	65.25	69.38		69.64	0.009906	4.36	128.90	133.20	0.43
Coal Creek	Coal Creek	5628.661	100-yr_565cfs	565.00	65.25	74.49		74.50	0.000066	0.68	949.85	195.12	0.04
Coal Creek	Coal Creek	5628.661	500-yr_698cfs	698.00	65.25	86.02		86.02	0.000002	0.21	3785.33	331.27	0.01
Coal Creek	Coal Creek	5592.64*	Average Annual	14.80	64.32	65.65		65.66	0.003754	1.12	13.27	17.47	0.23
Coal Creek	Coal Creek	5592.64*	Annual_98cfs	98.00	64.32	66.88		66.98	0.009400	2.56	38.32	81.04	0.35
Coal Creek	Coal Creek	5592.64*	1.25-yr_170cfs	170.00	64.32	67.53		67.69	0.011150	3.12	54.57	89.65	0.38
Coal Creek	Coal Creek	5592.64*	2-yr_234cfs	234.00	64.32	68.02		68.20	0.011417	3.43	71.35	123.81	0.39
Coal Creek	Coal Creek	5592.64*	5-yr_321cfs-	321.00	64.32	68.49		68.69	0.010523	3.71	102.28	145.80	0.38
Coal Creek	Coal Creek	5592.64*	10-yr_379cfs	379.00	64.32	68.79		68.99	0.009657	3.79	123.67	156.18	0.37

HEC-RAS Plan: HECexist1 Locations: User Defined (Continued)

River	Reach	River Sta	Profile	Q Total (cfs)	Min Ch El (ft)	W.S. Elev (ft)	Crit W.S. (ft)	E.G. Elev (ft)	E.G. Slope (ft/ft)	Vel Chnl (ft/s)	Flow Area (sq ft)	Top Width (ft)	Froude # Chl
Coal Creek	Coal Creek	5592.64*	25-yr_453cfs	453.00	64.32	69.07		69.28	0.009323	3.94	152.55	163.76	0.37
Coal Creek	Coal Creek	5592.64*	100-yr_565cfs	565.00	64.32	74.49		74.49	0.000040	0.48	1129.12	203.24	0.03
Coal Creek	Coal Creek	5592.64*	500-yr_698cfs	698.00	64.32	86.02		86.02	0.000001	0.16	4302.48	399.90	0.01
Coal Creek	Coal Creek	5556.62*	Average Annual	14.80	64.83	65.39	65.21	65.44	0.012079	1.73	8.58	21.29	0.48
Coal Creek	Coal Creek	5556.62*	Annual_98cfs	98.00	64.83	66.51	65.86	66.62	0.010532	2.66	36.78	29.00	0.42
Coal Creek	Coal Creek	5556.62*	1.25-yr_170cfs	170.00	64.83	67.16	66.23	67.30	0.010126	2.98	56.97	33.07	0.40
Coal Creek	Coal Creek	5556.62*	2-yr_234cfs	234.00	64.83	67.65	66.51	67.81	0.010007	3.14	76.41	51.71	0.39
Coal Creek	Coal Creek	5556.62*	5-yr_321cfs-	321.00	64.83	68.18	66.82	68.34	0.008531	3.29	107.42	62.51	0.37
Coal Creek	Coal Creek	5556.62*	10-yr_379cfs	379.00	64.83	68.51	67.02	68.67	0.007714	3.33	128.02	64.32	0.35
Coal Creek	Coal Creek	5556.62*	25-yr_453cfs	453.00	64.83	68.78	67.25	68.96	0.007924	3.52	146.02	90.56	0.36
Coal Creek	Coal Creek	5556.62*	100-yr_565cfs	565.00	64.83	74.49	67.64	74.49	0.000083	0.73	1174.99	228.41	0.04
Coal Creek	Coal Creek	5556.62*	500-yr_698cfs	698.00	64.83	86.02	68.01	86.02	0.000002	0.22	4593.14	426.28	0.01
Coal Creek	Coal Creek	5520.611	Average Annual	14.80	64.44	65.12	64.83	65.14	0.005568	1.28	11.58	22.53	0.31
Coal Creek	Coal Creek	5520.611	Annual_98cfs	98.00	64.44	66.18	65.44	66.28	0.008253	2.62	37.33	26.19	0.39
Coal Creek	Coal Creek	5520.611	1.25-yr_170cfs	170.00	64.44	66.79	65.82	66.94	0.009617	3.13	54.38	29.32	0.40
Coal Creek	Coal Creek	5520.611	2-yr_234cfs	234.00	64.44	67.27	66.10	67.45	0.009918	3.39	69.87	39.88	0.40
Coal Creek	Coal Creek	5520.611	5-yr_321cfs-	321.00	64.44	67.83	66.45	68.02	0.009051	3.60	94.74	46.17	0.39
Coal Creek	Coal Creek	5520.611	10-yr_379cfs	379.00	64.44	68.17	66.65	68.37	0.008620	3.70	111.15	86.34	0.38
Coal Creek	Coal Creek	5520.611	25-yr_453cfs	453.00	64.44	68.45	66.89	68.67	0.008231	3.85	153.00	157.54	0.38
Coal Creek	Coal Creek	5520.611	100-yr_565cfs	565.00	64.44	74.49	67.28	74.49	0.000051	0.62	1414.97	246.21	0.04
Coal Creek	Coal Creek	5520.611	500-yr_698cfs	698.00	64.44	86.02	67.67	86.02	0.000002	0.21	5021.36	432.16	0.01
Coal Creek	Coal Creek	5485.14*	Average Annual	14.80	64.11	64.53	64.53	64.69	0.051464	3.14	4.71	15.55	1.01
Coal Creek	Coal Creek	5485.14*	Annual_98cfs	98.00	64.11	65.38	65.25	65.71	0.039853	4.59	21.36	21.94	0.82
Coal Creek	Coal Creek	5485.14*	1.25-yr_170cfs	170.00	64.11	66.12	65.65	66.42	0.023764	4.40	38.64	25.01	0.62
Coal Creek	Coal Creek	5485.14*	2-yr_234cfs	234.00	64.11	66.63	65.95	66.94	0.020296	4.50	51.98	27.01	0.57
Coal Creek	Coal Creek	5485.14*	5-yr_321cfs-	321.00	64.11	67.24	66.31	67.57	0.017864	4.65	69.01	44.17	0.53
Coal Creek	Coal Creek	5485.14*	10-yr_379cfs	379.00	64.11	67.58	66.53	67.94	0.017145	4.77	79.38	79.07	0.52
Coal Creek	Coal Creek	5485.14*	25-yr_453cfs	453.00	64.11	68.12	66.78	68.35	0.009951	4.05	161.61	156.51	0.41
Coal Creek	Coal Creek	5485.14*	100-yr_565cfs	565.00	64.11	74.49	67.13	74.49	0.000040	0.54	1559.21	263.87	0.03
Coal Creek	Coal Creek	5485.14*	500-yr_698cfs	698.00	64.11	86.02	67.51	86.02	0.000002	0.19	5490.91	431.81	0.01
Coal Creek	Coal Creek	5449.67*	Average Annual	14.80	62.32	63.43	63.02	63.47	0.004040	1.63	9.07	13.31	0.35
Coal Creek	Coal Creek	5449.67*	Annual_98cfs	98.00	62.32	65.09	63.97	65.18	0.006293	2.46	39.81	23.06	0.33
Coal Creek	Coal Creek	5449.67*	1.25-yr_170cfs	170.00	62.32	65.79	64.46	65.92	0.007708	2.98	57.01	26.06	0.36
Coal Creek	Coal Creek	5449.67*	2-yr_234cfs	234.00	62.32	66.28	64.80	66.46	0.008544	3.32	70.48	28.08	0.37
Coal Creek	Coal Creek	5449.67*	5-yr_321cfs-	321.00	62.32	66.88	65.19	67.09	0.009156	3.64	88.08	68.36	0.38
Coal Creek	Coal Creek	5449.67*	10-yr_379cfs	379.00	62.32	67.23	65.42	67.45	0.009570	3.84	98.71	110.82	0.38
Coal Creek	Coal Creek	5449.67*	25-yr_453cfs	453.00	62.32	67.97	65.69	68.08	0.004713	2.87	228.06	152.56	0.27
Coal Creek	Coal Creek	5449.67*	100-yr_565cfs	565.00	62.32	74.48	66.07	74.49	0.000030	0.46	1736.09	290.44	0.03
Coal Creek	Coal Creek	5449.67*	500-yr_698cfs	698.00	62.32	86.02	66.48	86.02	0.000001	0.17	5839.97	429.89	0.01
Coal Creek	Coal Creek	5414.208	Average Annual	14.80	62.35	63.24	62.99	63.28	0.007125	1.71	8.63	17.16	0.43
Coal Creek	Coal Creek	5414.208	Annual_98cfs	98.00	62.35	64.90	63.75	64.98	0.004980	2.20	44.47	25.85	0.30
Coal Creek	Coal Creek	5414.208	1.25-yr_170cfs	170.00	62.35	65.55	64.18	65.67	0.006454	2.73	62.35	29.06	0.33
Coal Creek	Coal Creek	5414.208	2-yr_234cfs	234.00	62.35	66.02	64.49	66.17	0.007291	3.06	75.54	31.26	0.34
Coal Creek	Coal Creek	5414.208	5-yr_321cfs-	321.00	62.35	66.59	64.87	66.77	0.008509	3.36	95.48	64.08	0.36
Coal Creek	Coal Creek	5414.208	10-yr_379cfs	379.00	62.35	66.93	65.08	67.12	0.008774	3.51	108.60	97.53	0.36
Coal Creek	Coal Creek	5414.208	25-yr_453cfs	453.00	62.35	67.84	65.34	67.93	0.003423	2.55	242.76	138.31	0.23
Coal Creek	Coal Creek	5414.208	100-yr_565cfs	565.00	62.35	74.48	65.69	74.49	0.000029	0.47	1840.55	346.85	0.03
Coal Creek	Coal Creek	5414.208	500-yr_698cfs	698.00	62.35	86.02	66.08	86.02	0.000001	0.15	6513.56	427.58	0.01
Coal Creek	Coal Creek	5382.59*	Average Annual	14.80	61.82	63.14	62.56	63.17	0.002076	1.39	10.61	12.75	0.27
Coal Creek	Coal Creek	5382.59*	Annual_98cfs	98.00	61.82	64.68	63.55	64.77	0.008615	2.47	39.70	26.31	0.35
Coal Creek	Coal Creek	5382.59*	1.25-yr_170cfs	170.00	61.82	65.27	64.15	65.41	0.010420	3.02	56.32	29.53	0.39
Coal Creek	Coal Creek	5382.59*	2-yr_234cfs	234.00	61.82	65.71	64.48	65.89	0.010886	3.35	69.77	38.45	0.40
Coal Creek	Coal Creek	5382.59*	5-yr_321cfs-	321.00	61.82	66.25	64.86	66.46	0.011216	3.69	86.97	60.52	0.40
Coal Creek	Coal Creek	5382.59*	10-yr_379cfs	379.00	61.82	66.56	65.06	66.80	0.011676	3.88	97.74	85.96	0.41
Coal Creek	Coal Creek	5382.59*	25-yr_453cfs	453.00	61.82	67.75	65.31	67.82	0.002948	2.41	256.56	125.36	0.22
Coal Creek	Coal Creek	5382.59*	100-yr_565cfs	565.00	61.82	74.48	65.64	74.48	0.000027	0.45	1925.80	361.61	0.02
Coal Creek	Coal Creek	5382.59*	500-yr_698cfs	698.00	61.82	86.02	65.98	86.02	0.000001	0.15	6379.66	402.79	0.01
Coal Creek	Coal Creek	5350.99*	Average Annual	14.80	62.09	62.77	62.77	62.98	0.033377	3.66	4.05	9.85	1.01
Coal Creek	Coal Creek	5350.99*	Annual_98cfs	98.00	62.09	64.11	63.82	64.30	0.029947	3.55	27.63	27.70	0.63
Coal Creek	Coal Creek	5350.99*	1.25-yr_170cfs	170.00	62.09	64.75	64.17	64.96	0.020238	3.66	46.39	30.69	0.53
Coal Creek	Coal Creek	5350.99*	2-yr_234cfs	234.00	62.09	65.23	64.43	65.45	0.017277	3.79	61.75	53.37	0.49
Coal Creek	Coal Creek	5350.99*	5-yr_321cfs-	321.00	62.09	65.80	64.74	66.04	0.015746	3.94	81.40	78.89	0.46
Coal Creek	Coal Creek	5350.99*	10-yr_379cfs	379.00	62.09	66.12	64.93	66.37	0.015168	4.06	93.45	86.72	0.46
Coal Creek	Coal Creek	5350.99*	25-yr_453cfs	453.00	62.09	67.70	65.16	67.74	0.001914	1.94	311.15	133.72	0.17
Coal Creek	Coal Creek	5350.99*	100-yr_565cfs	565.00	62.09	74.48	65.48	74.48	0.000022	0.41	2009.70	336.87	0.02
Coal Creek	Coal Creek	5350.99*	500-yr_698cfs	698.00	62.09	86.02	65.82	86.02	0.000001	0.15	6175.00	379.26	0.01
Coal Creek	Coal Creek	5319.381	Average Annual	14.80	61.11	62.37	61.82	62.39	0.002719	1.36	10.91	15.37	0.28
Coal Creek	Coal Creek	5319.381	Annual_98cfs	98.00	61.11	63.77	62.78	63.85	0.007308	2.29	42.85	28.90	0.33
Coal Creek	Coal Creek	5319.381	1.25-yr_170cfs	170.00	61.11	64.45	63.23	64.56	0.007470	2.68	63.53	31.96	0.33
Coal Creek	Coal Creek	5319.381	2-yr_234cfs	234.00	61.11	64.95	63.53	65.08	0.007621	2.93	79.89	34.13	0.34
Coal Creek	Coal Creek	5319.381	5-yr_321cfs-	321.00	61.11	65.51	63.86	65.67	0.007938	3.21	99.86	55.35	0.34
Coal Creek	Coal Creek	5319.381	10-yr_379cfs	379.00	61.11	65.83	64.06	66.01	0.008179	3.39	111.82	58.98	0.35
Coal Creek	Coal Creek	5319.381	25-yr_453cfs	453.00	61.11	67.62	64.29	67.68	0.002011	2.05	264.41	97.43	0.18
Coal Creek	Coal Creek	5319.381	100-yr_565cfs	565.00	61.11	74.48	64.61	74.48	0.000029	0.47	1714.91	302.49	0.02
Coal Creek	Coal Creek	5319.381	500-yr_698cfs	698.00	61.11	86.02	64.96	86.02	0.000001	0.17	5585.46	358.43	0.01
Coal Creek	Coal Creek	5293.38*	Average Annual	14.80	61.36	62.29	61.90	62.31	0.003631	1.23	12.03	20.04	0.28
Coal Creek	Coal Creek	5293.38*	Annual_98cfs	98.00	61.36	63.60	62.60	63.69	0.005307	2.36	41.55	24.82	0.32
Coal Creek	Coal Creek	5293.38*	1.25-yr_170cfs	170.00	61.36	64.24	62.99	64.38	0.006726	2.92	58.16	27.24	0.35
Coal Creek	Coal Creek	5293.38*	2-yr_234cfs	234.00	61.36	64.71	63.30	64.88	0.007592	3.28	71.31	32.76	0.37
Coal Creek	Coal Creek	5293.38*	5-yr_321cfs-	321.00	61.36	65.24	63.67	65.45	0.008582	3.68	87.24	50.95	0.39
Coal Creek	Coal Creek	5293.38*	10-yr_379cfs	379.00	61.36	65.54	63.88	65.78	0.009250	3.92	96.62	54.68	0.40
Coal Creek	Coal Creek	5293.38*	25-yr_453cfs	453.00	61.36	67.57	64.15	67.63	0.001809	2.12	268.10	95.90	0.18
Coal Creek	Coal Creek	5293.38*	100-yr_565cfs	565.00	61.36	74.48	64.50	74.48	0.000030	0.5			

HEC-RAS Plan: HECexist1 Locations: User Defined (Continued)

River	Reach	River Sta	Profile	Q Total	Min Ch El	W.S. Elev	Crit W.S.	E.G. Elev	E.G. Slope	Vel Chnl	Flow Area	Top Width	Froude # Chl
				(cfs)	(ft)	(ft)	(ft)	(ft)	(ft/ft)	(ft/s)	(sq ft)	(ft)	
Coal Creek	Coal Creek	5267.39*	Average Annual	14.80	60.85	62.19	61.63	62.22	0.003262	1.37	10.80	15.97	0.29
Coal Creek	Coal Creek	5267.39*	Annual_98cfs	98.00	60.85	63.41	62.59	63.52	0.007817	2.70	36.27	23.82	0.39
Coal Creek	Coal Creek	5267.39*	1.25-yr_170cfs	170.00	60.85	63.99	63.01	64.16	0.010006	3.35	50.69	26.20	0.42
Coal Creek	Coal Creek	5267.39*	2-yr_234cfs	234.00	60.85	64.42	63.32	64.64	0.011116	3.75	62.36	27.85	0.44
Coal Creek	Coal Creek	5267.39*	5-yr_321cfs-	321.00	60.85	64.90	63.69	65.18	0.012368	4.20	76.35	47.03	0.46
Coal Creek	Coal Creek	5267.39*	10-yr_379cfs	379.00	60.85	65.17	63.90	65.48	0.013352	4.50	84.27	58.89	0.48
Coal Creek	Coal Creek	5267.39*	25-yr_453cfs	453.00	60.85	67.53	64.17	67.58	0.001576	2.03	287.69	101.73	0.17
Coal Creek	Coal Creek	5267.39*	100-yr_565cfs	565.00	60.85	74.48	64.53	74.48	0.000024	0.47	1835.65	315.68	0.02
Coal Creek	Coal Creek	5267.39*	500-yr_698cfs	698.00	60.85	86.02	64.91	86.02	0.000001	0.17	5691.58	350.46	0.01
Coal Creek	Coal Creek	5241.396	Average Annual	14.80	61.16	62.10	61.74	62.13	0.003670	1.39	10.65	18.91	0.33
Coal Creek	Coal Creek	5241.396	Annual_98cfs	98.00	61.16	63.17	62.49	63.30	0.009344	2.87	34.14	25.04	0.43
Coal Creek	Coal Creek	5241.396	1.25-yr_170cfs	170.00	61.16	63.66	62.90	63.86	0.013192	3.61	47.03	28.05	0.49
Coal Creek	Coal Creek	5241.396	2-yr_234cfs	234.00	61.16	64.05	63.21	64.30	0.014938	3.99	58.64	30.65	0.51
Coal Creek	Coal Creek	5241.396	5-yr_321cfs-	321.00	61.16	64.51	63.56	64.81	0.016572	4.38	73.28	33.62	0.52
Coal Creek	Coal Creek	5241.396	10-yr_379cfs	379.00	61.16	64.76	63.78	65.09	0.016806	4.63	82.50	48.27	0.53
Coal Creek	Coal Creek	5241.396	25-yr_453cfs	453.00	61.16	67.51	64.03	67.55	0.000876	1.73	431.77	261.83	0.14
Coal Creek	Coal Creek	5241.396	100-yr_565cfs	565.00	61.16	74.48	64.37	74.48	0.000010	0.34	2508.59	310.96	0.02
Coal Creek	Coal Creek	5241.396	500-yr_698cfs	698.00	61.16	86.02	64.73	86.02	0.000001	0.15	6378.92	353.92	0.01
Coal Creek	Coal Creek	5211.09*	Average Annual	14.80	61.06	61.72	61.72	61.86	0.041252	2.94	5.03	19.55	1.02
Coal Creek	Coal Creek	5211.09*	Annual_98cfs	98.00	61.06	62.33	62.33	62.72	0.052441	4.99	19.65	25.75	1.01
Coal Creek	Coal Creek	5211.09*	1.25-yr_170cfs	170.00	61.06	62.95	62.68	63.29	0.027303	4.65	36.53	28.43	0.72
Coal Creek	Coal Creek	5211.09*	2-yr_234cfs	234.00	61.06	63.24	62.95	63.66	0.029711	5.22	44.79	29.64	0.75
Coal Creek	Coal Creek	5211.09*	5-yr_321cfs-	321.00	61.06	63.61	63.27	64.12	0.030446	5.71	56.25	31.29	0.75
Coal Creek	Coal Creek	5211.09*	10-yr_379cfs	379.00	61.06	63.87	63.46	64.41	0.029729	5.88	64.42	32.44	0.74
Coal Creek	Coal Creek	5211.09*	25-yr_453cfs	453.00	61.06	67.47	63.69	67.52	0.001035	1.81	316.29	176.09	0.14
Coal Creek	Coal Creek	5211.09*	100-yr_565cfs	565.00	61.06	74.48	64.01	74.48	0.000011	0.33	2308.37	308.02	0.02
Coal Creek	Coal Creek	5211.09*	500-yr_698cfs	698.00	61.06	86.02	64.35	86.02	0.000001	0.15	6233.40	362.66	0.01
Coal Creek	Coal Creek	5180.79*	Average Annual	14.80	59.91	60.86	60.55	60.91	0.005193	1.80	8.24	14.77	0.42
Coal Creek	Coal Creek	5180.79*	Annual_98cfs	98.00	59.91	61.63	61.43	61.91	0.014331	4.24	23.13	24.20	0.76
Coal Creek	Coal Creek	5180.79*	1.25-yr_170cfs	170.00	59.91	62.22	61.87	62.49	0.024214	4.16	40.83	35.10	0.68
Coal Creek	Coal Creek	5180.79*	2-yr_234cfs	234.00	59.91	62.60	62.17	62.89	0.020000	4.29	54.51	36.94	0.62
Coal Creek	Coal Creek	5180.79*	5-yr_321cfs-	321.00	59.91	63.10	62.45	63.39	0.016489	4.38	73.36	39.10	0.56
Coal Creek	Coal Creek	5180.79*	10-yr_379cfs	379.00	59.91	63.41	62.61	63.72	0.015027	4.41	85.94	40.56	0.53
Coal Creek	Coal Creek	5180.79*	25-yr_453cfs	453.00	59.91	67.49	62.81	67.50	0.000193	0.95	718.20	272.77	0.07
Coal Creek	Coal Creek	5180.79*	100-yr_565cfs	565.00	59.91	74.48	63.09	74.48	0.000004	0.23	2756.89	312.56	0.01
Coal Creek	Coal Creek	5180.79*	500-yr_698cfs	698.00	59.91	86.02	63.39	86.02	0.000000	0.11	6769.79	376.69	0.00
Coal Creek	Coal Creek	5150.487	Average Annual	14.80	60.05	60.62	60.48	60.65	0.015278	1.40	10.57	38.23	0.47
Coal Creek	Coal Creek	5150.487	Annual_98cfs	98.00	60.05	61.46	60.94	61.53	0.008064	2.09	46.85	46.70	0.37
Coal Creek	Coal Creek	5150.487	1.25-yr_170cfs	170.00	60.05	62.02	61.19	62.10	0.006387	2.31	73.71	49.69	0.33
Coal Creek	Coal Creek	5150.487	2-yr_234cfs	234.00	60.05	62.45	61.37	62.54	0.005499	2.45	95.62	51.02	0.32
Coal Creek	Coal Creek	5150.487	5-yr_321cfs-	321.00	60.05	62.99	61.60	63.09	0.004804	2.60	123.36	52.41	0.30
Coal Creek	Coal Creek	5150.487	10-yr_379cfs	379.00	60.05	63.32	61.74	63.43	0.004510	2.69	140.87	53.23	0.29
Coal Creek	Coal Creek	5150.487	25-yr_453cfs	453.00	60.05	67.49	61.90	67.49	0.000095	0.63	857.42	265.47	0.04
Coal Creek	Coal Creek	5150.487	100-yr_565cfs	565.00	60.05	74.48	62.12	74.48	0.000003	0.19	2953.11	330.45	0.01
Coal Creek	Coal Creek	5150.487	500-yr_698cfs	698.00	60.05	86.02	62.37	86.02	0.000000	0.09	7217.98	392.98	0.00
Coal Creek	Coal Creek	5126.07*	Average Annual	14.80	59.53	59.94	59.94	60.08	0.037861	3.08	4.80	16.62	1.01
Coal Creek	Coal Creek	5126.07*	Annual_98cfs	98.00	59.53	60.64	60.64	61.11	0.041162	5.47	17.92	19.39	1.00
Coal Creek	Coal Creek	5126.07*	1.25-yr_170cfs	170.00	59.53	61.06	61.06	61.72	0.042010	6.50	26.15	19.98	1.00
Coal Creek	Coal Creek	5126.07*	2-yr_234cfs	234.00	59.53	61.38	61.38	62.18	0.042867	7.17	32.62	20.37	1.00
Coal Creek	Coal Creek	5126.07*	5-yr_321cfs-	321.00	59.53	61.77	61.77	62.74	0.044333	7.90	40.64	20.90	1.00
Coal Creek	Coal Creek	5126.07*	10-yr_379cfs	379.00	59.53	62.00	62.00	63.08	0.045619	8.33	45.52	21.21	1.00
Coal Creek	Coal Creek	5126.07*	25-yr_453cfs	453.00	59.53	67.48	62.30	67.49	0.000173	0.84	808.33	295.17	0.06
Coal Creek	Coal Creek	5126.07*	100-yr_565cfs	565.00	59.53	74.48	62.72	74.48	0.000005	0.23	3076.91	360.69	0.01
Coal Creek	Coal Creek	5126.07*	500-yr_698cfs	698.00	59.53	86.02	63.14	86.02	0.000000	0.11	7836.78	424.20	0.00
Coal Creek	Coal Creek	5101.66*	Average Annual	14.80	55.30	56.66	56.04	56.68	0.001484	1.21	12.23	15.43	0.24
Coal Creek	Coal Creek	5101.66*	Annual_98cfs	98.00	55.30	56.34	56.97	58.88	0.246164	12.78	7.67	13.08	2.94
Coal Creek	Coal Creek	5101.66*	1.25-yr_170cfs	170.00	55.30	56.67	57.43	59.60	0.189175	13.73	12.38	15.51	2.71
Coal Creek	Coal Creek	5101.66*	2-yr_234cfs	234.00	55.30	56.91	57.76	60.10	0.166716	14.33	16.33	17.37	2.60
Coal Creek	Coal Creek	5101.66*	5-yr_321cfs-	321.00	55.30	59.69	58.14	59.93	0.003504	3.94	81.40	28.91	0.41
Coal Creek	Coal Creek	5101.66*	10-yr_379cfs	379.00	55.30	62.61	58.38	62.68	0.000972	2.17	174.90	35.05	0.17
Coal Creek	Coal Creek	5101.66*	25-yr_453cfs	453.00	55.30	67.48	58.67	67.48	0.000084	0.76	995.27	397.14	0.05
Coal Creek	Coal Creek	5101.66*	100-yr_565cfs	565.00	55.30	74.48	59.06	74.48	0.000004	0.23	3946.72	434.66	0.01
Coal Creek	Coal Creek	5101.66*	500-yr_698cfs	698.00	55.30	86.02	59.47	86.02	0.000000	0.11	8994.40	437.69	0.00
Coal Creek	Coal Creek	5077.248	Average Annual	14.80	55.78	56.50	56.40	56.59	0.015065	2.40	6.16	16.06	0.68
Coal Creek	Coal Creek	5077.248	Annual_98cfs	98.00	55.78	57.14	57.14	57.59	0.025032	5.40	18.15	20.28	1.01
Coal Creek	Coal Creek	5077.248	1.25-yr_170cfs	170.00	55.78	57.55	57.55	58.18	0.022309	6.35	26.79	21.20	1.00
Coal Creek	Coal Creek	5077.248	2-yr_234cfs	234.00	55.78	57.85	57.85	58.62	0.021677	7.04	33.26	21.83	1.00
Coal Creek	Coal Creek	5077.248	5-yr_321cfs-	321.00	55.78	59.53	58.24	59.83	0.004713	4.41	72.78	25.71	0.46
Coal Creek	Coal Creek	5077.248	10-yr_379cfs	379.00	55.78	62.58	58.46	62.66	0.001343	2.27	167.09	35.76	0.18
Coal Creek	Coal Creek	5077.248	25-yr_453cfs	453.00	55.78	67.48	58.73	67.48	0.000053	0.63	1297.51	387.05	0.04
Coal Creek	Coal Creek	5077.248	100-yr_565cfs	565.00	55.78	74.48	59.12	74.48	0.000003	0.22	4283.67	450.11	0.01
Coal Creek	Coal Creek	5077.248	500-yr_698cfs	698.00	55.78	86.02	59.54	86.02	0.000000	0.11	9488.28	451.17	0.00
Coal Creek	Coal Creek	5067.673	Average Annual	14.80	55.84	56.26	56.26	56.37	0.038503	2.71	5.47	24.02	1.00
Coal Creek	Coal Creek	5067.673	Annual_98cfs	98.00	55.84	56.70	56.82	57.25	0.047965	6.00	16.34	25.37	1.32
Coal Creek	Coal Creek	5067.673	1.25-yr_170cfs	170.00	55.84	56.92	57.17	57.83	0.053891	7.64	22.24	26.07	1.46
Coal Creek	Coal Creek	5067.673	2-yr_234cfs	234.00	55.84	57.11	57.43	58.27	0.054574	8.63	27.11	26.64	1.51
Coal Creek	Coal Creek	5067.673	5-yr_321cfs-	321.00	55.84	59.60	59.75	59.75	0.002051	3.13	102.63	33.94	0.32
Coal Creek	Coal Creek	5067.673	10-yr_379cfs	379.00	55.84	62.58	62.64	62.64	0.000528	1.68	257.38	81.43	0.13
Coal Creek	Coal Creek	5067.673	25-yr_453cfs	453.00	55.84	67.49	67.48	67.48	0.000021	0.49	1574.28	334.44	0.03
Coal Creek	Coal Creek	5067.673	100-yr_565cfs	565.00	55.84	74.48	74.48	74.48	0.000002	0.22	4050.32	373.21	0.01
Coal Creek	Coal Creek	5067.673	500-yr_698cfs	698.00	55.84	86.02	86.02	86.02	0.000000	0.13	8663.35	421.21	0.00
Coal Creek	Coal Creek	5044.837	Average Annual	14.80	54.84	55.24	55.26						

River	Reach	River Sta	Profile	Q Total (cfs)	Min Ch El (ft)	W.S. Elev (ft)	Crit W.S. (ft)	E.G. Elev (ft)	E.G. Slope (ft/ft)	Vel Chnl (ft/s)	Flow Area (sq ft)	Top Width (ft)	Froude # Chl
Coal Creek	Coal Creek	5044.837	1.25-yr_170cfs	170.00	54.84	56.02	56.17	56.75	0.038034	6.85	24.82	26.38	1.24
Coal Creek	Coal Creek	5044.837	2-yr_234cfs	234.00	54.84	57.30	56.43	57.53	0.004425	3.83	61.02	30.14	0.47
Coal Creek	Coal Creek	5044.837	5-yr_321cfs-	321.00	54.84	59.62		59.70	0.001040	2.32	138.58	36.85	0.21
Coal Creek	Coal Creek	5044.837	10-yr_379cfs	379.00	54.84	62.60		62.62	0.000281	1.30	399.71	216.65	0.09
Coal Creek	Coal Creek	5044.837	25-yr_453cfs	453.00	54.84	67.48		67.48	0.000015	0.45	1911.52	340.07	0.02
Coal Creek	Coal Creek	5044.837	100-yr_565cfs	565.00	54.84	74.48		74.48	0.000002	0.23	4426.54	379.44	0.01
Coal Creek	Coal Creek	5044.837	500-yr_698cfs	698.00	54.84	86.02		86.02	0.000000	0.14	9086.65	425.40	0.00
Coal Creek	Coal Creek	5022.706	Average Annual	14.80	53.84	54.49	54.26	54.52	0.003657	1.32	11.24	24.75	0.34
Coal Creek	Coal Creek	5022.706	Annual_98cfs	98.00	53.84	55.51	54.82	55.61	0.003320	2.58	38.01	27.81	0.39
Coal Creek	Coal Creek	5022.706	1.25-yr_170cfs	170.00	53.84	56.15	55.17	56.29	0.002955	3.01	56.47	29.70	0.38
Coal Creek	Coal Creek	5022.706	2-yr_234cfs	234.00	53.84	57.35		57.44	0.001350	2.49	94.04	33.19	0.26
Coal Creek	Coal Creek	5022.706	5-yr_321cfs-	321.00	53.84	59.62		59.67	0.000625	1.81	184.05	69.54	0.15
Coal Creek	Coal Creek	5022.706	10-yr_379cfs	379.00	53.84	62.60		62.62	0.000131	0.99	660.78	285.49	0.07
Coal Creek	Coal Creek	5022.706	25-yr_453cfs	453.00	53.84	67.48		67.48	0.000010	0.38	2254.44	345.62	0.02
Coal Creek	Coal Creek	5022.706	100-yr_565cfs	565.00	53.84	74.48		74.48	0.000002	0.22	4809.26	386.01	0.01
Coal Creek	Coal Creek	5022.706	500-yr_698cfs	698.00	53.84	86.02		86.02	0.000000	0.13	9513.68	427.60	0.00
Coal Creek	Coal Creek	5002.2	Average Annual	14.80	53.73	54.18	54.18	54.34	0.036113	3.17	4.67	15.33	1.01
Coal Creek	Coal Creek	5002.2	Annual_98cfs	98.00	53.73	54.95	54.95	55.43	0.025062	5.57	17.58	18.49	1.01
Coal Creek	Coal Creek	5002.2	1.25-yr_170cfs	170.00	53.73	55.88		56.18	0.008556	4.45	43.53	44.07	0.63
Coal Creek	Coal Creek	5002.2	2-yr_234cfs	234.00	53.73	57.34		57.40	0.002290	2.18	148.23	84.69	0.25
Coal Creek	Coal Creek	5002.2	5-yr_321cfs-	321.00	53.73	59.64		59.65	0.000436	1.08	371.64	109.52	0.10
Coal Creek	Coal Creek	5002.2	10-yr_379cfs	379.00	53.73	62.61		62.61	0.000089	0.61	786.82	180.66	0.04
Coal Creek	Coal Creek	5002.2	25-yr_453cfs	453.00	53.73	67.48		67.48	0.000012	0.34	1983.10	270.66	0.02
Coal Creek	Coal Creek	5002.2	100-yr_565cfs	565.00	53.73	74.48		74.48	0.000002	0.21	4009.14	304.27	0.01
Coal Creek	Coal Creek	5002.2	500-yr_698cfs	698.00	53.73	86.02		86.02	0.000000	0.13	7776.59	347.32	0.00
Coal Creek	Coal Creek	4975.96	Average Annual	14.80	52.73	53.17	53.18	53.34	0.040083	3.27	4.52	15.29	1.06
Coal Creek	Coal Creek	4975.96	Annual_98cfs	98.00	52.73	53.75	53.94	54.51	0.049345	6.96	14.07	17.69	1.38
Coal Creek	Coal Creek	4975.96	1.25-yr_170cfs	170.00	52.73	55.98		56.04	0.001233	2.09	118.57	80.68	0.25
Coal Creek	Coal Creek	4975.96	2-yr_234cfs	234.00	52.73	57.34		57.36	0.000582	1.37	238.14	95.46	0.14
Coal Creek	Coal Creek	4975.96	5-yr_321cfs-	321.00	52.73	59.63		59.64	0.000191	0.84	487.11	125.88	0.07
Coal Creek	Coal Creek	4975.96	10-yr_379cfs	379.00	52.73	62.61		62.61	0.000046	0.54	984.67	220.69	0.04
Coal Creek	Coal Creek	4975.96	25-yr_453cfs	453.00	52.73	67.48		67.48	0.000008	0.31	2256.56	276.56	0.02
Coal Creek	Coal Creek	4975.96	100-yr_565cfs	565.00	52.73	74.48		74.48	0.000002	0.20	4315.34	308.16	0.01
Coal Creek	Coal Creek	4975.96	500-yr_698cfs	698.00	52.73	86.02		86.02	0.000000	0.14	8124.90	349.31	0.00
Coal Creek	Coal Creek	4954.856	Average Annual	14.80	51.73	52.14	52.15	52.35	0.055529	3.62	4.09	15.18	1.23
Coal Creek	Coal Creek	4954.856	Annual_98cfs	98.00	51.73	54.24	52.95	54.30	0.001470	2.00	62.98	70.14	0.27
Coal Creek	Coal Creek	4954.856	1.25-yr_170cfs	170.00	51.73	55.99		56.01	0.000313	1.24	206.22	91.78	0.13
Coal Creek	Coal Creek	4954.856	2-yr_234cfs	234.00	51.73	57.34		57.35	0.000157	1.03	339.11	106.26	0.10
Coal Creek	Coal Creek	4954.856	5-yr_321cfs-	321.00	51.73	59.63		59.64	0.000056	0.78	625.87	152.13	0.06
Coal Creek	Coal Creek	4954.856	10-yr_379cfs	379.00	51.73	62.60		62.61	0.000016	0.57	1227.94	253.89	0.04
Coal Creek	Coal Creek	4954.856	25-yr_453cfs	453.00	51.73	67.48		67.48	0.000003	0.35	2536.29	283.13	0.02
Coal Creek	Coal Creek	4954.856	100-yr_565cfs	565.00	51.73	74.48		74.48	0.000001	0.25	4625.37	312.05	0.01
Coal Creek	Coal Creek	4954.856	500-yr_698cfs	698.00	51.73	86.02		86.02	0.000000	0.18	8475.06	350.65	0.01
Coal Creek	Coal Creek	4933.66	Average Annual	14.80	50.73	52.06	51.18	52.07	0.000400	0.75	19.78	18.98	0.13
Coal Creek	Coal Creek	4933.66	Annual_98cfs	98.00	50.73	54.26		54.28	0.000267	1.02	141.91	83.88	0.12
Coal Creek	Coal Creek	4933.66	1.25-yr_170cfs	170.00	50.73	56.00		56.01	0.000112	0.83	303.76	102.61	0.08
Coal Creek	Coal Creek	4933.66	2-yr_234cfs	234.00	50.73	57.34		57.35	0.000070	0.77	451.03	117.91	0.07
Coal Creek	Coal Creek	4933.66	5-yr_321cfs-	321.00	50.73	59.63		59.64	0.000030	0.64	791.93	181.77	0.05
Coal Creek	Coal Creek	4933.66	10-yr_379cfs	379.00	50.73	62.61		62.61	0.000010	0.48	1485.56	260.30	0.03
Coal Creek	Coal Creek	4933.66	25-yr_453cfs	453.00	50.73	67.48		67.48	0.000002	0.32	2822.44	288.80	0.02
Coal Creek	Coal Creek	4933.66	100-yr_565cfs	565.00	50.73	74.48		74.48	0.000001	0.24	4939.38	315.94	0.01
Coal Creek	Coal Creek	4933.66	500-yr_698cfs	698.00	50.73	86.02		86.02	0.000000	0.17	8825.71	350.65	0.01
Coal Creek	Coal Creek	4914.324	Average Annual	14.80	50.73	52.06		52.06	0.000410	0.75	19.63	18.95	0.13
Coal Creek	Coal Creek	4914.324	Annual_98cfs	98.00	50.73	54.26		54.27	0.000213	0.91	141.71	83.86	0.11
Coal Creek	Coal Creek	4914.324	1.25-yr_170cfs	170.00	50.73	56.00		56.00	0.000080	0.70	303.75	102.61	0.07
Coal Creek	Coal Creek	4914.324	2-yr_234cfs	234.00	50.73	57.34		57.34	0.000049	0.64	451.07	117.91	0.06
Coal Creek	Coal Creek	4914.324	5-yr_321cfs-	321.00	50.73	59.64		59.64	0.000021	0.53	792.03	181.80	0.04
Coal Creek	Coal Creek	4914.324	10-yr_379cfs	379.00	50.73	62.61		62.61	0.000007	0.39	1485.70	260.31	0.02
Coal Creek	Coal Creek	4914.324	25-yr_453cfs	453.00	50.73	67.48		67.48	0.000001	0.25	2822.51	288.80	0.01
Coal Creek	Coal Creek	4914.324	100-yr_565cfs	565.00	50.73	74.48		74.48	0.000000	0.18	4939.42	315.94	0.01
Coal Creek	Coal Creek	4914.324	500-yr_698cfs	698.00	50.73	86.02		86.02	0.000000	0.12	8825.74	350.65	0.00
Coal Creek	Coal Creek	4908.637	Average Annual	14.80	50.90	51.88	51.88	52.04	0.033953	3.24	4.57	12.87	0.96
Coal Creek	Coal Creek	4908.637	Annual_98cfs	98.00	50.90	54.23		54.27	0.000681	1.51	67.79	42.90	0.18
Coal Creek	Coal Creek	4908.637	1.25-yr_170cfs	170.00	50.90	55.98		56.00	0.000233	1.19	181.75	97.25	0.12
Coal Creek	Coal Creek	4908.637	2-yr_234cfs	234.00	50.90	57.33		57.34	0.000102	1.00	321.85	110.97	0.08
Coal Creek	Coal Creek	4908.637	5-yr_321cfs-	321.00	50.90	59.63		59.64	0.000035	0.76	599.42	127.55	0.05
Coal Creek	Coal Creek	4908.637	10-yr_379cfs	379.00	50.90	62.60		62.61	0.000011	0.56	1002.47	145.03	0.03
Coal Creek	Coal Creek	4908.637	25-yr_453cfs	453.00	50.90	67.48		67.48	0.000003	0.40	1814.32	216.34	0.02
Coal Creek	Coal Creek	4908.637	100-yr_565cfs	565.00	50.90	74.48		74.48	0.000001	0.27	3488.97	257.88	0.01
Coal Creek	Coal Creek	4908.637	500-yr_698cfs	698.00	50.90	86.02		86.02	0.000000	0.18	7769.81	308.55	0.01
Coal Creek	Coal Creek	4903.362	Average Annual	14.80	47.00	51.51	47.50	51.51	0.000027	0.40	37.94	9.46	0.03
Coal Creek	Coal Creek	4903.362	Annual_98cfs	98.00	47.00	54.24		54.26	0.000150	0.94	109.83	43.67	0.09
Coal Creek	Coal Creek	4903.362	1.25-yr_170cfs	170.00	47.00	55.99		56.00	0.000108	0.95	224.44	97.81	0.08
Coal Creek	Coal Creek	4903.362	2-yr_234cfs	234.00	47.00	57.33		57.34	0.000063	0.87	364.82	111.33	0.06
Coal Creek	Coal Creek	4903.362	5-yr_321cfs-	321.00	47.00	59.63		59.64	0.000027	0.71	642.93	127.76	0.04
Coal Creek	Coal Creek	4903.362	10-yr_379cfs	379.00	47.00	62.60		62.61	0.000010	0.53	1046.31	145.05	0.03
Coal Creek	Coal Creek	4903.362	25-yr_453cfs	453.00	47.00	67.48		67.48	0.000003	0.39	1858.16	216.34	0.02
Coal Creek	Coal Creek	4903.362	100-yr_565cfs	565.00	47.00	74.48		74.48	0.000001	0.27	3532.81	257.88	0.01
Coal Creek	Coal Creek	4903.362	500-yr_698cfs	698.00	47.00	86.02		86.02	0.000000	0.18	6813.65	308.55	0.01
Coal Creek	Coal Creek	4897.104	Average Annual	14.80	47.00	51.51	47.49	51.51	0.000021	0.37	44.57	12.49	0.03
Coal Creek	Coal Creek	4897.104	Annual_98cfs	98.00	47.00	54.23	48.71	54.26	0.000158	1.44	80.10	48.22	0.10
Coal Creek	Coal Creek	4897.104	1.25-yr_170cfs	170.00	47.00	55.94	49.44	55.99	0.000216	1.95	103.26	102.51	0.12
Coal Creek	Coal Creek	4897.104	2-yr_234cfs	234.00	47.00	57.26	49.98	57.33	0.000247	2.29	121.09	113.32	0.13
Coal Creek	Coal Creek	4897.104	5-yr_321cfs-	321.00	47.00	59.54	50.62	59.63	0.000226	2.51	151.89	128.66	

HEC-RAS Plan: HECexist1 Locations: User Defined (Continued)

River	Reach	River Sta	Profile	Q Total (cfs)	Min Ch El (ft)	W.S. Elev (ft)	Crit W.S. (ft)	E.G. Elev (ft)	E.G. Slope (ft/ft)	Vel Chnl (ft/s)	Flow Area (sq ft)	Top Width (ft)	Froude # Chl
Coal Creek	Coal Creek	4897.104	10-yr_379cfs	379.00	47.00	62.53	51.01	62.60	0.000147	2.35	192.15	144.84	0.11
Coal Creek	Coal Creek	4897.104	25-yr_453cfs	453.00	47.00	67.42	51.46	67.47	0.000110	2.01	273.96	215.93	0.09
Coal Creek	Coal Creek	4897.104	100-yr_565cfs	565.00	47.00	74.48	52.10	74.48	0.000012	0.58	1642.02	257.87	0.03
Coal Creek	Coal Creek	4897.104	500-yr_698cfs	698.00	47.00	86.01	52.82	86.02	0.000001	0.23	4923.45	308.55	0.01
Coal Creek	Coal Creek	4892	Inl Struct										
Coal Creek	Coal Creek	4887.114	Average Annual	14.80	47.20	51.50		51.50	0.000010	0.23	64.49	15.00	0.02
Coal Creek	Coal Creek	4887.114	Annual_98cfs	98.00	47.20	54.07		54.09	0.000119	0.95	103.08	15.00	0.06
Coal Creek	Coal Creek	4887.114	1.25-yr_170cfs	170.00	47.20	55.64		55.67	0.000208	1.34	126.63	15.00	0.08
Coal Creek	Coal Creek	4887.114	2-yr_234cfs	234.00	47.20	56.84		56.88	0.000279	1.62	144.56	15.00	0.09
Coal Creek	Coal Creek	4887.114	5-yr_321cfs-	321.00	47.20	59.07		59.12	0.000308	1.80	178.12	15.00	0.09
Coal Creek	Coal Creek	4887.114	10-yr_379cfs	379.00	47.20	61.98		62.02	0.000249	1.71	221.64	15.00	0.08
Coal Creek	Coal Creek	4887.114	25-yr_453cfs	453.00	47.20	66.41		66.45	0.000189	1.57	288.14	15.00	0.06
Coal Creek	Coal Creek	4887.114	100-yr_565cfs	565.00	47.20	74.43		74.46	0.000131	1.38	408.42	15.00	0.05
Coal Creek	Coal Creek	4887.114	500-yr_698cfs	698.00	47.20	85.98		86.00	0.000090	1.20	581.67	15.00	0.03
Coal Creek	Coal Creek	4885	Average Annual	14.80	47.20	51.50		51.50	0.000010	0.23	64.49	15.00	0.02
Coal Creek	Coal Creek	4885	Annual_98cfs	98.00	47.20	54.07		54.09	0.000119	0.95	103.08	15.00	0.06
Coal Creek	Coal Creek	4885	1.25-yr_170cfs	170.00	47.20	55.64		55.67	0.000208	1.34	126.63	15.00	0.08
Coal Creek	Coal Creek	4885	2-yr_234cfs	234.00	47.20	56.84		56.88	0.000279	1.62	144.55	15.00	0.09
Coal Creek	Coal Creek	4885	5-yr_321cfs-	321.00	47.20	59.07		59.12	0.000308	1.80	178.11	15.00	0.09
Coal Creek	Coal Creek	4885	10-yr_379cfs	379.00	47.20	61.98		62.02	0.000250	1.71	221.64	15.00	0.08
Coal Creek	Coal Creek	4885	25-yr_453cfs	453.00	47.20	66.41		66.45	0.000189	1.57	288.14	15.00	0.06
Coal Creek	Coal Creek	4885	100-yr_565cfs	565.00	47.20	74.43		74.46	0.000131	1.38	408.41	15.00	0.05
Coal Creek	Coal Creek	4885	500-yr_698cfs	698.00	47.20	85.98		86.00	0.000090	1.20	581.67	15.00	0.03
Coal Creek	Coal Creek	4883	Average Annual	14.80	47.20	51.50		51.50	0.000010	0.23	64.49	15.00	0.02
Coal Creek	Coal Creek	4883	Annual_98cfs	98.00	47.20	54.07		54.09	0.000119	0.95	103.08	15.00	0.06
Coal Creek	Coal Creek	4883	1.25-yr_170cfs	170.00	47.20	55.64		55.67	0.000208	1.34	126.62	15.00	0.08
Coal Creek	Coal Creek	4883	2-yr_234cfs	234.00	47.20	56.84		56.88	0.000279	1.62	144.54	15.00	0.09
Coal Creek	Coal Creek	4883	5-yr_321cfs-	321.00	47.20	59.07		59.12	0.000308	1.80	178.10	15.00	0.09
Coal Creek	Coal Creek	4883	10-yr_379cfs	379.00	47.20	61.98		62.02	0.000250	1.71	221.63	15.00	0.08
Coal Creek	Coal Creek	4883	25-yr_453cfs	453.00	47.20	66.41		66.45	0.000189	1.57	288.13	15.00	0.06
Coal Creek	Coal Creek	4883	100-yr_565cfs	565.00	47.20	74.43		74.46	0.000131	1.38	408.41	15.00	0.05
Coal Creek	Coal Creek	4883	500-yr_698cfs	698.00	47.20	85.98		86.00	0.000090	1.20	581.67	15.00	0.03
Coal Creek	Coal Creek	4881	Average Annual	14.80	47.20	51.50		51.50	0.000010	0.23	64.49	15.00	0.02
Coal Creek	Coal Creek	4881	Annual_98cfs	98.00	47.20	54.07		54.09	0.000119	0.95	103.08	15.00	0.06
Coal Creek	Coal Creek	4881	1.25-yr_170cfs	170.00	47.20	55.64		55.67	0.000208	1.34	126.61	15.00	0.08
Coal Creek	Coal Creek	4881	2-yr_234cfs	234.00	47.20	56.84		56.88	0.000279	1.62	144.53	15.00	0.09
Coal Creek	Coal Creek	4881	5-yr_321cfs-	321.00	47.20	59.07		59.12	0.000308	1.80	178.09	15.00	0.09
Coal Creek	Coal Creek	4881	10-yr_379cfs	379.00	47.20	61.97		62.02	0.000250	1.71	221.62	15.00	0.08
Coal Creek	Coal Creek	4881	25-yr_453cfs	453.00	47.20	66.41		66.45	0.000189	1.57	288.13	15.00	0.06
Coal Creek	Coal Creek	4881	100-yr_565cfs	565.00	47.20	74.43		74.46	0.000131	1.38	408.40	15.00	0.05
Coal Creek	Coal Creek	4881	500-yr_698cfs	698.00	47.20	85.98		86.00	0.000090	1.20	581.66	15.00	0.03
Coal Creek	Coal Creek	4864.693	Average Annual	14.80	47.20	51.50	47.56	51.50	0.000009	0.29	51.59	15.00	0.02
Coal Creek	Coal Creek	4864.693	Annual_98cfs	98.00	47.20	54.06	48.47	54.08	0.000079	1.19	82.35	15.00	0.08
Coal Creek	Coal Creek	4864.693	1.25-yr_170cfs	170.00	47.20	55.62	49.03	55.67	0.000120	1.68	101.08	15.00	0.10
Coal Creek	Coal Creek	4864.693	2-yr_234cfs	234.00	47.20	56.81	49.47	56.87	0.000146	2.03	115.32	15.00	0.12
Coal Creek	Coal Creek	4864.693	5-yr_321cfs-	321.00	47.20	59.04	50.00	59.12	0.000137	2.26	142.09	15.00	0.12
Coal Creek	Coal Creek	4864.693	10-yr_379cfs	379.00	47.20	61.95	50.33	62.02	0.000092	2.14	176.95	15.00	0.10
Coal Creek	Coal Creek	4864.693	25-yr_453cfs	453.00	47.20	66.38	50.72	66.44	0.000055	1.97	230.21	15.00	0.08
Coal Creek	Coal Creek	4864.693	100-yr_565cfs	565.00	47.20	74.41	51.28	74.45	0.000027	1.73	326.50	15.00	0.06
Coal Creek	Coal Creek	4864.693	500-yr_698cfs	698.00	47.20	85.96	51.90	86.00	0.000012	1.50	465.16	15.00	0.04
Coal Creek	Coal Creek	4650 I-405	Culvert										
Coal Creek	Coal Creek	4393.951	Average Annual	14.80	45.16	46.25	45.72	46.27	0.002768	1.31	11.30	14.05	0.26
Coal Creek	Coal Creek	4393.951	Annual_98cfs	98.00	45.16	47.55	46.60	47.71	0.005028	3.23	30.79	15.87	0.40
Coal Creek	Coal Creek	4393.951	1.25-yr_170cfs	170.00	45.16	48.25	47.10	48.52	0.005627	4.15	42.27	16.79	0.44
Coal Creek	Coal Creek	4393.951	2-yr_234cfs	234.00	45.16	48.78	47.49	49.13	0.005913	4.78	51.31	17.85	0.46
Coal Creek	Coal Creek	4393.951	5-yr_321cfs-	321.00	45.16	49.40	47.96	49.85	0.006172	5.47	62.92	19.93	0.49
Coal Creek	Coal Creek	4393.951	10-yr_379cfs	379.00	45.16	49.76	48.25	50.28	0.006308	5.87	70.39	55.42	0.50
Coal Creek	Coal Creek	4393.951	25-yr_453cfs	453.00	45.16	50.18	48.58	50.77	0.006439	6.31	79.63	67.97	0.51
Coal Creek	Coal Creek	4393.951	100-yr_565cfs	565.00	45.16	50.75	49.10	51.45	0.006583	6.89	92.49	68.33	0.53
Coal Creek	Coal Creek	4393.951	500-yr_698cfs	698.00	45.16	51.35	49.66	52.17	0.006796	7.52	106.07	68.71	0.55

ATTACHMENT D

HEC-RAS Plan: HEC Design 1 Locations: User Defined

HEC-RAS Plan: HECdesign1 Locations: User Defined

River	Reach	River Sta	Profile	Q Total (cfs)	Min Ch El (ft)	W.S. Elev (ft)	Crit W.S. (ft)	E.G. Elev (ft)	E.G. Slope (ft/ft)	Vel Chnl (ft/s)	Flow Area (sq ft)	Top Width (ft)	Froude # Chl
Coal Creek	Coal Creek	7602.644	Average Annual	14.80	91.29	92.12	92.05	92.26	0.020197	3.04	4.87	11.02	0.81
Coal Creek	Coal Creek	7602.644	Annual_98cfs	98.00	91.29	93.04	92.97	93.48	0.020606	5.33	18.40	18.06	0.93
Coal Creek	Coal Creek	7602.644	1.25-yr_170cfs	170.00	91.29	93.45	93.45	94.09	0.022731	6.43	26.43	20.97	1.01
Coal Creek	Coal Creek	7602.644	2-yr_234cfs	234.00	91.29	93.79	93.79	94.53	0.021807	6.90	33.90	23.43	1.01
Coal Creek	Coal Creek	7602.644	5-yr_321cfs-	321.00	91.29	94.17	94.17	95.02	0.020843	7.38	43.50	26.26	1.01
Coal Creek	Coal Creek	7602.644	10-yr_379cfs	379.00	91.29	94.40	94.40	95.30	0.020341	7.62	49.72	28.06	1.01
Coal Creek	Coal Creek	7602.644	25-yr_453cfs	453.00	91.29	94.67	94.67	95.63	0.019812	7.88	57.47	30.24	1.01
Coal Creek	Coal Creek	7602.644	100-yr_565cfs	565.00	91.29	95.01	95.01	96.07	0.018853	8.28	68.34	33.10	1.00
Coal Creek	Coal Creek	7602.644	500-yr_698cfs	698.00	91.29	95.36	95.36	96.55	0.018011	8.73	80.59	36.10	1.00
Coal Creek	Coal Creek	7252.914	Average Annual	14.80	86.23	87.00		87.09	0.011249	2.37	6.24	13.22	0.61
Coal Creek	Coal Creek	7252.914	Annual_98cfs	98.00	86.23	88.03		88.26	0.011065	3.88	25.23	25.15	0.68
Coal Creek	Coal Creek	7252.914	1.25-yr_170cfs	170.00	86.23	88.50	88.17	88.80	0.010596	4.38	38.84	31.32	0.69
Coal Creek	Coal Creek	7252.914	2-yr_234cfs	234.00	86.23	88.83	88.45	89.18	0.010220	4.70	49.74	35.03	0.70
Coal Creek	Coal Creek	7252.914	5-yr_321cfs-	321.00	86.23	89.21	88.77	89.60	0.009783	5.03	63.80	39.29	0.70
Coal Creek	Coal Creek	7252.914	10-yr_379cfs	379.00	86.23	89.41	88.97	89.84	0.009827	5.28	71.80	41.28	0.71
Coal Creek	Coal Creek	7252.914	25-yr_453cfs	453.00	86.23	89.63	89.17	90.12	0.009789	5.57	81.32	42.95	0.71
Coal Creek	Coal Creek	7252.914	100-yr_565cfs	565.00	86.23	89.94	89.47	90.49	0.009834	5.97	94.67	45.20	0.73
Coal Creek	Coal Creek	7252.914	500-yr_698cfs	698.00	86.23	90.25	89.77	90.89	0.009938	6.38	109.38	47.56	0.74
Coal Creek	Coal Creek	7034.648	Average Annual	14.80	84.00	84.34		84.40	0.013364	2.01	7.37	23.00	0.62
Coal Creek	Coal Creek	7034.648	Annual_98cfs	98.00	84.00	84.94	84.84	85.24	0.017694	4.40	22.29	26.24	0.84
Coal Creek	Coal Creek	7034.648	1.25-yr_170cfs	170.00	84.00	85.27	85.19	85.73	0.019326	5.48	31.01	27.91	0.92
Coal Creek	Coal Creek	7034.648	2-yr_234cfs	234.00	84.00	85.57	85.46	86.10	0.020230	6.20	37.74	29.15	0.96
Coal Creek	Coal Creek	7034.648	5-yr_321cfs-	321.00	84.00	85.78	85.78	86.54	0.021172	6.98	45.96	30.64	1.01
Coal Creek	Coal Creek	7034.648	10-yr_379cfs	379.00	84.00	85.97	85.97	86.80	0.020653	7.30	51.94	31.80	1.01
Coal Creek	Coal Creek	7034.648	25-yr_453cfs	453.00	84.00	86.22	86.22	87.10	0.020164	7.53	60.16	34.50	1.00
Coal Creek	Coal Creek	7034.648	100-yr_565cfs	565.00	84.00	86.56	86.56	87.50	0.019702	7.78	72.58	38.92	1.00
Coal Creek	Coal Creek	7034.648	500-yr_698cfs	698.00	84.00	86.90	86.90	87.91	0.019340	8.05	86.66	43.55	1.01
Coal Creek	Coal Creek	6903.79*	Average Annual	14.80	82.00	82.31	82.25	82.38	0.017940	2.17	6.83	23.70	0.71
Coal Creek	Coal Creek	6903.79*	Annual_98cfs	98.00	82.00	83.01	82.83	83.25	0.013086	3.88	25.25	28.67	0.73
Coal Creek	Coal Creek	6903.79*	1.25-yr_170cfs	170.00	82.00	83.42		83.74	0.011928	4.52	37.60	31.57	0.73
Coal Creek	Coal Creek	6903.79*	2-yr_234cfs	234.00	82.00	83.73		84.11	0.011211	4.90	47.72	33.80	0.73
Coal Creek	Coal Creek	6903.79*	5-yr_321cfs-	321.00	82.00	84.10	83.72	84.54	0.010459	5.28	60.78	36.49	0.72
Coal Creek	Coal Creek	6903.79*	10-yr_379cfs	379.00	82.00	84.34	83.90	84.80	0.009845	5.44	69.68	38.21	0.71
Coal Creek	Coal Creek	6903.79*	25-yr_453cfs	453.00	82.00	84.63	84.12	85.12	0.009166	5.59	80.97	40.29	0.70
Coal Creek	Coal Creek	6903.79*	100-yr_565cfs	565.00	82.00	84.96	84.41	85.51	0.009156	5.97	94.68	42.69	0.71
Coal Creek	Coal Creek	6903.79*	500-yr_698cfs	698.00	82.00	86.10	84.73	86.44	0.004053	4.70	148.57	54.41	0.49
Coal Creek	Coal Creek	6772.943	Average Annual	14.80	80.00	80.40		80.47	0.012065	2.09	7.07	19.16	0.61
Coal Creek	Coal Creek	6772.943	Annual_98cfs	98.00	80.00	81.12		81.42	0.014790	4.35	22.52	23.46	0.78
Coal Creek	Coal Creek	6772.943	1.25-yr_170cfs	170.00	80.00	81.51		81.95	0.015660	5.31	32.04	25.78	0.84
Coal Creek	Coal Creek	6772.943	2-yr_234cfs	234.00	80.00	81.79	81.64	82.34	0.016218	5.93	39.44	27.47	0.87
Coal Creek	Coal Creek	6772.943	5-yr_321cfs-	321.00	80.00	82.10	81.98	82.79	0.017162	6.65	48.24	29.46	0.92
Coal Creek	Coal Creek	6772.943	10-yr_379cfs	379.00	80.00	82.26	82.19	83.05	0.018336	7.14	53.04	30.57	0.96
Coal Creek	Coal Creek	6772.943	25-yr_453cfs	453.00	80.00	82.43	82.43	83.36	0.019910	7.75	58.49	32.00	1.01
Coal Creek	Coal Creek	6772.943	100-yr_565cfs	565.00	80.00	82.74	82.74	83.80	0.018810	8.25	69.13	36.44	1.00
Coal Creek	Coal Creek	6772.943	500-yr_698cfs	698.00	80.00	85.95		86.13	0.001203	3.52	255.04	76.81	0.29
Coal Creek	Coal Creek	6643.38*	Average Annual	14.80	77.19	77.76	77.76	77.92	0.036845	3.22	4.60	15.05	1.03
Coal Creek	Coal Creek	6643.38*	Annual_98cfs	98.00	77.19	78.51	78.51	78.94	0.025612	5.28	18.55	21.86	1.01
Coal Creek	Coal Creek	6643.38*	1.25-yr_170cfs	170.00	77.19	79.01	78.91	79.48	0.023324	6.09	27.90	24.67	1.01
Coal Creek	Coal Creek	6643.38*	2-yr_234cfs	234.00	77.19	79.29	79.20	79.88	0.022287	6.58	35.54	26.98	1.01
Coal Creek	Coal Creek	6643.38*	5-yr_321cfs-	321.00	77.19	79.63	79.63	80.31	0.021390	6.58	49.20	40.80	1.00
Coal Creek	Coal Creek	6643.38*	10-yr_379cfs	379.00	77.19	79.89	79.89	80.52	0.020076	6.43	62.16	62.62	0.97
Coal Creek	Coal Creek	6643.38*	25-yr_453cfs	453.00	77.19	80.06	80.06	80.75	0.019279	6.73	73.74	68.03	0.96
Coal Creek	Coal Creek	6643.38*	100-yr_565cfs	565.00	77.19	80.19	80.32	81.09	0.022634	7.69	82.52	71.27	1.06
Coal Creek	Coal Creek	6643.38*	500-yr_698cfs	698.00	77.19	86.02		86.05	0.000118	1.53	854.33	198.32	0.10
Coal Creek	Coal Creek	6513.829	Average Annual	14.80	74.01	74.89	74.61	74.94	0.005676	1.80	8.21	15.76	0.44
Coal Creek	Coal Creek	6513.829	Annual_98cfs	98.00	74.01	75.80	75.44	76.00	0.008477	3.56	27.53	25.46	0.60
Coal Creek	Coal Creek	6513.829	1.25-yr_170cfs	170.00	74.01	76.35	75.83	76.61	0.006960	4.07	41.73	26.84	0.58
Coal Creek	Coal Creek	6513.829	2-yr_234cfs	234.00	74.01	76.77	76.10	77.07	0.006234	4.40	53.17	27.75	0.56
Coal Creek	Coal Creek	6513.829	5-yr_321cfs-	321.00	74.01	77.21	76.43	77.58	0.006132	4.88	65.71	28.66	0.57
Coal Creek	Coal Creek	6513.829	10-yr_379cfs	379.00	74.01	77.44	76.63	77.87	0.006432	5.24	72.33	29.32	0.59
Coal Creek	Coal Creek	6513.829	25-yr_453cfs	453.00	74.01	77.70	76.88	78.20	0.006876	5.66	79.99	30.25	0.61
Coal Creek	Coal Creek	6513.829	100-yr_565cfs	565.00	74.01	78.03	77.20	78.64	0.007567	6.25	90.39	31.59	0.65
Coal Creek	Coal Creek	6513.829	500-yr_698cfs	698.00	74.01	86.01		86.04	0.000070	1.42	948.05	202.25	0.08
Coal Creek	Coal Creek	6386.04*	Average Annual	14.80	73.46	74.10		74.15	0.006878	1.64	9.04	23.23	0.46
Coal Creek	Coal Creek	6386.04*	Annual_98cfs	98.00	73.46	75.19		75.30	0.003543	2.65	37.05	27.68	0.40
Coal Creek	Coal Creek	6386.04*	1.25-yr_170cfs	170.00	73.46	75.89		76.03	0.002825	2.97	57.23	29.98	0.38
Coal Creek	Coal Creek	6386.04*	2-yr_234cfs	234.00	73.46	76.34		76.51	0.002813	3.29	71.11	31.68	0.39
Coal Creek	Coal Creek	6386.04*	5-yr_321cfs-	321.00	73.46	76.76		76.98	0.003221	3.78	87.44	50.40	0.42
Coal Creek	Coal Creek	6386.04*	10-yr_379cfs	379.00	73.46	76.98		77.24	0.003344	4.07	100.97	66.39	0.44
Coal Creek	Coal Creek	6386.04*	25-yr_453cfs	453.00	73.46	77.23		77.53	0.003484	4.41	118.17	72.38	0.45
Coal Creek	Coal Creek	6386.04*	100-yr_565cfs	565.00	73.46	77.56		77.91	0.003681	4.86	143.43	81.96	0.47
Coal Creek	Coal Creek	6386.04*	500-yr_698cfs	698.00	73.46	86.02		86.03	0.000032	1.05	1520.55	253.73	0.05
Coal Creek	Coal Creek	6258.266	Average Annual	14.80	72.31	73.05		73.12	0.009364	2.17	6.82	14.38	0.56
Coal Creek	Coal Creek	6258.266	Annual_98cfs	98.00	72.31	74.23		74.56	0.011050	2.99	32.81	22.89	0.44
Coal Creek	Coal Creek	6258.266	1.25-yr_170cfs	170.00	72.31	75.23		75.38	0.011495	3.18	54.78	38.88	0.41
Coal Creek													

River	Reach	River Sta	Profile	Q Total (cfs)	Min Ch El (ft)	W.S. Elev (ft)	Crit W.S. (ft)	E.G. Elev (ft)	E.G. Slope (ft/ft)	Vel Chnl (ft/s)	Flow Area (sq ft)	Top Width (ft)	Froude # Chl
Coal Creek	Coal Creek	6140.08*	2-yr_234cfs	234.00	71.55	74.59		74.78	0.007611	3.52	74.16	66.60	0.40
Coal Creek	Coal Creek	6140.08*	5-yr_321cfs-	321.00	71.55	75.02		75.23	0.007341	3.86	106.83	85.13	0.40
Coal Creek	Coal Creek	6140.08*	10-yr_379cfs	379.00	71.55	75.26	73.95	75.49	0.007174	4.03	128.72	95.69	0.40
Coal Creek	Coal Creek	6140.08*	25-yr_453cfs	453.00	71.55	75.53	74.26	75.77	0.006988	4.21	156.53	107.64	0.40
Coal Creek	Coal Creek	6140.08*	100-yr_565cfs	565.00	71.55	75.71		76.01	0.008618	4.83	175.80	115.18	0.45
Coal Creek	Coal Creek	6140.08*	500-yr_698cfs	698.00	71.55	86.02		86.02	0.000011	0.42	3115.14	356.16	0.02
Coal Creek	Coal Creek	6021.9	Average Annual	14.80	69.97	70.57	70.57	70.75	0.034144	3.40	4.35	12.41	1.01
Coal Creek	Coal Creek	6021.9	Annual_98cfs	98.00	69.97	71.39	71.39	71.82	0.057980	5.26	18.61	22.11	1.01
Coal Creek	Coal Creek	6021.9	1.25-yr_170cfs	170.00	69.97	71.77	71.77	72.37	0.058977	6.18	27.50	23.72	1.01
Coal Creek	Coal Creek	6021.9	2-yr_234cfs	234.00	69.97	72.06	72.06	72.78	0.058978	6.78	34.50	24.67	1.01
Coal Creek	Coal Creek	6021.9	5-yr_321cfs-	321.00	69.97	72.41	72.41	73.26	0.059934	7.40	43.40	26.06	1.01
Coal Creek	Coal Creek	6021.9	10-yr_379cfs	379.00	69.97	72.65	72.63	73.55	0.058674	7.60	49.84	27.21	0.99
Coal Creek	Coal Creek	6021.9	25-yr_453cfs	453.00	69.97	72.97	72.90	73.89	0.055770	7.72	58.75	31.24	0.95
Coal Creek	Coal Creek	6021.9	100-yr_565cfs	565.00	69.97	74.61		74.93	0.009696	4.76	159.93	113.02	0.44
Coal Creek	Coal Creek	6021.9	500-yr_698cfs	698.00	69.97	86.02		86.02	0.000006	0.31	3806.03	389.39	0.01
Coal Creek	Coal Creek	5960.99*	Average Annual	14.80	67.30	68.89	68.01	68.90	0.000677	0.87	17.06	19.76	0.16
Coal Creek	Coal Creek	5960.99*	Annual_98cfs	98.00	67.30	70.57	68.94	70.61	0.001373	1.70	57.48	26.98	0.21
Coal Creek	Coal Creek	5960.99*	1.25-yr_170cfs	170.00	67.30	71.31	69.36	71.39	0.001964	2.17	78.43	29.08	0.23
Coal Creek	Coal Creek	5960.99*	2-yr_234cfs	234.00	67.30	71.83	69.66	71.92	0.002441	2.50	93.65	30.54	0.25
Coal Creek	Coal Creek	5960.99*	5-yr_321cfs-	321.00	67.30	72.33	70.02	72.46	0.003278	2.93	109.48	33.40	0.28
Coal Creek	Coal Creek	5960.99*	10-yr_379cfs	379.00	67.30	72.60		72.76	0.003659	3.20	122.17	64.16	0.30
Coal Creek	Coal Creek	5960.99*	25-yr_453cfs	453.00	67.30	72.88		73.07	0.003974	3.50	144.24	93.03	0.31
Coal Creek	Coal Creek	5960.99*	100-yr_565cfs	565.00	67.30	74.62		74.70	0.001145	2.41	365.06	155.15	0.18
Coal Creek	Coal Creek	5960.99*	500-yr_698cfs	698.00	67.30	86.02		86.02	0.000009	0.46	3020.87	402.14	0.02
Coal Creek	Coal Creek	5900.08	Average Annual	14.80	67.79	68.78	68.37	68.82	0.003589	1.61	9.21	14.69	0.36
Coal Creek	Coal Creek	5900.08	Annual_98cfs	98.00	67.79	70.36	69.27	70.46	0.005023	2.62	37.46	21.58	0.35
Coal Creek	Coal Creek	5900.08	1.25-yr_170cfs	170.00	67.79	71.01	69.76	71.17	0.007514	3.23	52.57	34.64	0.39
Coal Creek	Coal Creek	5900.08	2-yr_234cfs	234.00	67.79	71.44	70.12	71.65	0.009301	3.66	63.94	46.05	0.42
Coal Creek	Coal Creek	5900.08	5-yr_321cfs-	321.00	67.79	71.83	70.55	72.11	0.011011	4.30	76.78	67.55	0.46
Coal Creek	Coal Creek	5900.08	10-yr_379cfs	379.00	67.79	72.03	70.79	72.37	0.012223	4.69	86.40	87.45	0.49
Coal Creek	Coal Creek	5900.08	25-yr_453cfs	453.00	67.79	72.24	71.08	72.64	0.013373	5.12	101.29	106.84	0.51
Coal Creek	Coal Creek	5900.08	100-yr_565cfs	565.00	67.79	74.59	71.47	74.62	0.000921	1.96	502.48	189.97	0.15
Coal Creek	Coal Creek	5900.08	500-yr_698cfs	698.00	67.79	86.02	71.93	86.02	0.000008	0.38	3049.57	261.58	0.02
Coal Creek	Coal Creek	5840.97*	Average Annual	14.80	67.69	68.52		68.55	0.005832	1.48	10.01	20.84	0.38
Coal Creek	Coal Creek	5840.97*	Annual_98cfs	98.00	67.69	70.15		70.21	0.003228	1.99	49.19	26.74	0.26
Coal Creek	Coal Creek	5840.97*	1.25-yr_170cfs	170.00	67.69	70.70		70.80	0.004766	2.64	64.54	29.88	0.31
Coal Creek	Coal Creek	5840.97*	2-yr_234cfs	234.00	67.69	71.06		71.21	0.005650	3.11	78.61	55.72	0.34
Coal Creek	Coal Creek	5840.97*	5-yr_321cfs-	321.00	67.69	71.39		71.59	0.006691	3.66	104.53	104.22	0.38
Coal Creek	Coal Creek	5840.97*	10-yr_379cfs	379.00	67.69	71.58		71.79	0.006988	3.90	124.68	109.44	0.39
Coal Creek	Coal Creek	5840.97*	25-yr_453cfs	453.00	67.69	71.79		72.03	0.007185	4.14	148.90	114.79	0.40
Coal Creek	Coal Creek	5840.97*	100-yr_565cfs	565.00	67.69	74.56		74.58	0.000472	1.59	575.88	176.25	0.11
Coal Creek	Coal Creek	5840.97*	500-yr_698cfs	698.00	67.69	86.02		86.02	0.000006	0.37	2998.04	249.55	0.02
Coal Creek	Coal Creek	5781.861	Average Annual	14.80	66.58	67.89		67.96	0.022231	2.05	7.21	10.07	0.43
Coal Creek	Coal Creek	5781.861	Annual_98cfs	98.00	66.58	69.89		69.92	0.007750	1.42	68.38	65.94	0.19
Coal Creek	Coal Creek	5781.861	1.25-yr_170cfs	170.00	66.58	70.42		70.46	0.006252	1.50	111.38	89.55	0.18
Coal Creek	Coal Creek	5781.861	2-yr_234cfs	234.00	66.58	70.79		70.83	0.006155	1.42	147.38	104.69	0.17
Coal Creek	Coal Creek	5781.861	5-yr_321cfs-	321.00	66.58	71.11		71.16	0.006257	1.57	182.08	111.65	0.18
Coal Creek	Coal Creek	5781.861	10-yr_379cfs	379.00	66.58	71.30		71.35	0.006322	1.66	203.37	115.51	0.18
Coal Creek	Coal Creek	5781.861	25-yr_453cfs	453.00	66.58	71.51		71.58	0.006395	1.76	228.42	118.48	0.18
Coal Creek	Coal Creek	5781.861	100-yr_565cfs	565.00	66.58	74.54		74.55	0.000449	0.75	664.68	175.10	0.05
Coal Creek	Coal Creek	5781.861	500-yr_698cfs	698.00	66.58	86.02		86.02	0.000008	0.21	2957.18	234.77	0.01
Coal Creek	Coal Creek	5730.79*	Average Annual	14.80	65.84	67.00		67.08	0.013607	2.24	6.61	10.00	0.49
Coal Creek	Coal Creek	5730.79*	Annual_98cfs	98.00	65.84	69.31		69.37	0.015850	2.08	47.75	35.37	0.27
Coal Creek	Coal Creek	5730.79*	1.25-yr_170cfs	170.00	65.84	69.91		69.99	0.014735	2.38	78.35	64.91	0.27
Coal Creek	Coal Creek	5730.79*	2-yr_234cfs	234.00	65.84	70.28		70.35	0.015007	2.36	110.97	96.79	0.27
Coal Creek	Coal Creek	5730.79*	5-yr_321cfs-	321.00	65.84	70.61		70.70	0.014057	2.49	144.27	102.02	0.26
Coal Creek	Coal Creek	5730.79*	10-yr_379cfs	379.00	65.84	70.80		70.89	0.013771	2.57	163.82	105.00	0.26
Coal Creek	Coal Creek	5730.79*	25-yr_453cfs	453.00	65.84	71.01		71.11	0.013650	2.68	186.45	108.36	0.26
Coal Creek	Coal Creek	5730.79*	100-yr_565cfs	565.00	65.84	74.52		74.53	0.000509	0.85	691.89	173.35	0.07
Coal Creek	Coal Creek	5730.79*	500-yr_698cfs	698.00	65.84	86.02		86.02	0.000008	0.20	3412.89	300.56	0.01
Coal Creek	Coal Creek	5679.72*	Average Annual	14.80	65.06	66.68		66.70	0.004377	1.07	13.85	15.60	0.20
Coal Creek	Coal Creek	5679.72*	Annual_98cfs	98.00	65.06	68.90		68.93	0.005230	1.42	73.45	69.83	0.18
Coal Creek	Coal Creek	5679.72*	1.25-yr_170cfs	170.00	65.06	69.56		69.59	0.004464	1.60	128.17	100.46	0.18
Coal Creek	Coal Creek	5679.72*	2-yr_234cfs	234.00	65.06	69.93		69.97	0.004330	1.72	170.29	119.16	0.18
Coal Creek	Coal Creek	5679.72*	5-yr_321cfs-	321.00	65.06	70.25		70.30	0.004762	1.94	209.32	125.30	0.19
Coal Creek	Coal Creek	5679.72*	10-yr_379cfs	379.00	65.06	70.43		70.48	0.005046	2.06	231.95	129.11	0.20
Coal Creek	Coal Creek	5679.72*	25-yr_453cfs	453.00	65.06	70.63		70.68	0.005418	2.22	257.70	133.30	0.20
Coal Creek	Coal Creek	5679.72*	100-yr_565cfs	565.00	65.06	74.50		74.51	0.000235	0.75	906.46	193.94	0.05
Coal Creek	Coal Creek	5679.72*	500-yr_698cfs	698.00	65.06	86.02		86.02	0.000006	0.23	3755.01	329.76	0.01
Coal Creek	Coal Creek	5628.661	Average Annual	14.80	65.26	66.10		66.21	0.034172	2.60	5.88	12.75	0.58
Coal Creek	Coal Creek	5628.661	Annual_98cfs	98.00	65.26	68.42		68.50	0.015551	2.26	44.05	87.30	0.29
Coal Creek	Coal Creek	5628.661	1.25-yr_170cfs	170.00	65.26	69.18		69.24	0.011611	2.20	88.39	121.79	0.25
Coal Creek	Coal Creek	5628.661	2-yr_234cfs	234.00	65.26	69.55		69.62	0.011928	2.27	114.10	128.26	0.25
Coal Creek	Coal Creek	5628.661	5-yr_321cfs-	321.00	65.26	69.80		69.90	0.014551	2.67	131.41	147.43	0.28
Coal Creek	Coal Creek	5628.661	10-yr_379cfs	379.00	65.26	69.93		70.05	0.016388	2.93	143.15	155.99	0.30
Coal Creek	Coal Creek	5628.661	25-yr_453cfs	453.00	65.26	70.08		70.22	0.017942	3.17	162.90	159.34	0.32
Coal Creek	Coal Creek	5628.661	100-yr_565cfs	565.00	65.26	74.49		74.50	0.000098	0.43	919.31	195.17	0.03
Coal Creek	Coal Creek	5628.661	500-yr_698cfs	698.00	65.26	86.02		86.02	0.000002	0.13	3754.26	331.27	0.01
Coal Creek	Coal Creek	5592.64*	Average Annual	14.80	64.32	65.78		65.82	0.004851	1.52	9.72	8.00	0.24
Coal Creek	Coal Creek	5592.64*	Annual_98cfs	98.00	64.32	67.69		67.80	0.024244	2.66	36.82	82.80	0.33
Coal Creek	Coal Creek	5592.64*	1.25-yr_170cfs	170.00	64.32	68.55		68.64	0.025911	2.60	75.69	146.71	0.32
Coal Creek	Coal Creek	5592.64*	2-yr_234cfs	234.00	64.32	69.03		69.10	0.017504	2.46	114.85	163.55	0.27
Coal Creek	Coal Creek	5592.64*	5-yr_321cfs-	321.00	64.32	69.35		69.41	0.011924	2.20	168.76	165.08	0.23
Coal Creek	Coal Creek	5592.64*	10-yr_379cfs	379.00	64.32	69.49		69.56	0.010779	2.16	192.12	165.75	0.22

River	Reach	River Sta	Profile	Q Total (cfs)	Min Ch El (ft)	W.S. Elev (ft)	Crit W.S. (ft)	E.G. Elev (ft)	E.G. Slope (ft/ft)	Vel Chnl (ft/s)	Flow Area (sq ft)	Top Width (ft)	Froude # Chl
Coal Creek	Coal Creek	5592.64*	25-yr_453cfs	453.00	64.32	69.68		69.75	0.009066	2.07	223.38	166.67	0.20
Coal Creek	Coal Creek	5592.64*	100-yr_565cfs	565.00	64.32	74.49		74.50	0.000054	0.30	1099.24	203.25	0.02
Coal Creek	Coal Creek	5592.64*	500-yr_698cfs	698.00	64.32	86.02		86.02	0.000002	0.09	4272.24	399.90	0.00
Coal Creek	Coal Creek	5556.62*	Average Annual	14.80	64.83	65.40	65.30	65.51	0.018107	2.63	5.63	12.58	0.69
Coal Creek	Coal Creek	5556.62*	Annual_98cfs	98.00	64.83	66.90	66.22	67.03	0.018618	2.88	34.08	23.40	0.42
Coal Creek	Coal Creek	5556.62*	1.25-yr_170cfs	170.00	64.83	67.71	66.61	67.85	0.018371	3.01	56.73	33.70	0.38
Coal Creek	Coal Creek	5556.62*	2-yr_234cfs	234.00	64.83	68.24	66.91	68.38	0.022941	3.04	82.67	62.90	0.38
Coal Creek	Coal Creek	5556.62*	5-yr_321cfs	321.00	64.83	68.75	67.31	68.88	0.017921	3.09	115.33	84.90	0.35
Coal Creek	Coal Creek	5556.62*	10-yr_379cfs	379.00	64.83	68.84	67.50	69.01	0.021665	3.47	121.49	98.47	0.39
Coal Creek	Coal Creek	5556.62*	25-yr_453cfs	453.00	64.83	69.05	67.75	69.25	0.022565	3.72	135.78	113.68	0.40
Coal Creek	Coal Creek	5556.62*	100-yr_565cfs	565.00	64.83	74.49	68.31	74.49	0.000130	0.59	1147.18	228.43	0.04
Coal Creek	Coal Creek	5556.62*	500-yr_698cfs	698.00	64.83	86.02	68.57	86.02	0.000003	0.17	4564.76	426.28	0.01
Coal Creek	Coal Creek	5520.611	Average Annual	14.80	64.44	65.26	64.83	65.28	0.002617	0.99	14.92	23.10	0.22
Coal Creek	Coal Creek	5520.611	Annual_98cfs	98.00	64.44	66.70	65.44	66.76	0.003622	1.89	51.89	28.98	0.25
Coal Creek	Coal Creek	5520.611	1.25-yr_170cfs	170.00	64.44	67.49	65.82	67.56	0.004015	2.22	79.29	44.66	0.26
Coal Creek	Coal Creek	5520.611	2-yr_234cfs	234.00	64.44	67.98	66.10	68.07	0.004073	2.46	102.07	59.72	0.26
Coal Creek	Coal Creek	5520.611	5-yr_321cfs	321.00	64.44	68.52	66.45	68.62	0.003732	2.63	163.72	159.36	0.26
Coal Creek	Coal Creek	5520.611	10-yr_379cfs	379.00	64.44	68.53	66.65	68.67	0.005106	3.08	165.70	159.74	0.30
Coal Creek	Coal Creek	5520.611	25-yr_453cfs	453.00	64.44	68.75	66.89	68.89	0.005270	3.26	200.02	164.10	0.31
Coal Creek	Coal Creek	5520.611	100-yr_565cfs	565.00	64.44	74.49	67.28	74.49	0.000051	0.62	1415.34	246.22	0.04
Coal Creek	Coal Creek	5520.611	500-yr_698cfs	698.00	64.44	86.02	67.67	86.02	0.000002	0.21	5021.37	432.16	0.01
Coal Creek	Coal Creek	5485.14*	Average Annual	14.80	64.18	64.80	64.80	65.00	0.056563	3.59	4.12	10.15	0.99
Coal Creek	Coal Creek	5485.14*	Annual_98cfs	98.00	64.18	65.83	65.81	66.35	0.096058	5.78	16.94	15.52	0.98
Coal Creek	Coal Creek	5485.14*	1.25-yr_170cfs	170.00	64.18	66.72	66.30	67.14	0.091661	5.19	32.76	23.03	0.77
Coal Creek	Coal Creek	5485.14*	2-yr_234cfs	234.00	64.18	67.26	66.77	67.67	0.064730	5.16	45.39	39.62	0.66
Coal Creek	Coal Creek	5485.14*	5-yr_321cfs	321.00	64.18	67.77	67.13	68.23	0.070016	5.49	58.67	116.32	0.66
Coal Creek	Coal Creek	5485.14*	10-yr_379cfs	379.00	64.18	68.08	67.35	68.29	0.033778	4.13	126.93	150.21	0.47
Coal Creek	Coal Creek	5485.14*	25-yr_453cfs	453.00	64.18	68.42	67.67	68.54	0.022145	3.28	181.55	165.60	0.37
Coal Creek	Coal Creek	5485.14*	100-yr_565cfs	565.00	64.18	74.49	68.21	74.49	0.000053	0.36	1531.21	263.88	0.02
Coal Creek	Coal Creek	5485.14*	500-yr_698cfs	698.00	64.18	86.02	68.26	86.02	0.000002	0.12	5462.53	431.81	0.00
Coal Creek	Coal Creek	5449.67*	Average Annual	14.80	62.32	63.90	63.02	63.92	0.001081	0.92	16.01	15.99	0.16
Coal Creek	Coal Creek	5449.67*	Annual_98cfs	98.00	62.32	65.93	63.97	65.97	0.002184	1.61	60.72	26.63	0.19
Coal Creek	Coal Creek	5449.67*	1.25-yr_170cfs	170.00	62.32	66.64	64.46	66.71	0.003185	2.10	80.88	45.57	0.22
Coal Creek	Coal Creek	5449.67*	2-yr_234cfs	234.00	62.32	67.12	64.80	67.21	0.003989	2.46	95.30	97.45	0.25
Coal Creek	Coal Creek	5449.67*	5-yr_321cfs	321.00	62.32	67.52	65.19	67.66	0.005473	2.96	108.36	136.68	0.29
Coal Creek	Coal Creek	5449.67*	10-yr_379cfs	379.00	62.32	67.63	65.42	67.81	0.007080	3.39	111.87	142.58	0.33
Coal Creek	Coal Creek	5449.67*	25-yr_453cfs	453.00	62.32	68.21	65.69	68.29	0.003318	2.51	265.09	158.63	0.23
Coal Creek	Coal Creek	5449.67*	100-yr_565cfs	565.00	62.32	74.49	66.07	74.49	0.000030	0.46	1736.42	290.45	0.03
Coal Creek	Coal Creek	5449.67*	500-yr_698cfs	698.00	62.32	86.02	66.48	86.02	0.000001	0.17	5839.98	429.89	0.01
Coal Creek	Coal Creek	5414.208	Average Annual	14.80	62.35	63.88	62.99	63.88	0.000754	0.72	20.69	20.55	0.13
Coal Creek	Coal Creek	5414.208	Annual_98cfs	98.00	62.35	65.87	63.75	65.90	0.001499	1.36	71.86	30.56	0.16
Coal Creek	Coal Creek	5414.208	1.25-yr_170cfs	170.00	62.35	66.56	64.18	66.61	0.002451	1.80	94.27	60.68	0.19
Coal Creek	Coal Creek	5414.208	2-yr_234cfs	234.00	62.35	67.01	64.49	67.08	0.003063	2.11	112.40	105.31	0.22
Coal Creek	Coal Creek	5414.208	5-yr_321cfs	321.00	62.35	67.43	64.87	67.50	0.003095	2.24	186.14	131.53	0.22
Coal Creek	Coal Creek	5414.208	10-yr_379cfs	379.00	62.35	67.51	65.08	67.60	0.003814	2.53	197.37	133.51	0.24
Coal Creek	Coal Creek	5414.208	25-yr_453cfs	453.00	62.35	68.12	65.34	68.18	0.002397	2.24	281.56	143.07	0.20
Coal Creek	Coal Creek	5414.208	100-yr_565cfs	565.00	62.35	74.48	65.69	74.49	0.000029	0.47	1840.94	346.87	0.03
Coal Creek	Coal Creek	5414.208	500-yr_698cfs	698.00	62.35	86.02	66.08	86.02	0.000001	0.15	6513.57	427.58	0.01
Coal Creek	Coal Creek	5382.59*	Average Annual	14.80	61.82	63.81	62.65	63.84	0.004318	1.26	11.73	10.26	0.21
Coal Creek	Coal Creek	5382.59*	Annual_98cfs	98.00	61.82	65.68	64.10	65.77	0.024130	2.39	40.97	32.32	0.34
Coal Creek	Coal Creek	5382.59*	1.25-yr_170cfs	170.00	61.82	66.28	64.97	66.42	0.026184	2.99	56.94	55.27	0.36
Coal Creek	Coal Creek	5382.59*	2-yr_234cfs	234.00	61.82	66.79	65.30	66.88	0.020272	2.52	109.14	108.96	0.31
Coal Creek	Coal Creek	5382.59*	5-yr_321cfs	321.00	61.82	67.25	65.79	67.32	0.012814	2.29	162.57	119.52	0.26
Coal Creek	Coal Creek	5382.59*	10-yr_379cfs	379.00	61.82	67.29	66.00	67.38	0.016452	2.63	167.23	119.91	0.29
Coal Creek	Coal Creek	5382.59*	25-yr_453cfs	453.00	61.82	68.01	66.24	68.06	0.006513	1.95	256.75	129.86	0.19
Coal Creek	Coal Creek	5382.59*	100-yr_565cfs	565.00	61.82	74.48	66.81	74.49	0.000038	0.31	1893.36	361.61	0.02
Coal Creek	Coal Creek	5382.59*	500-yr_698cfs	698.00	61.82	86.02	66.98	86.02	0.000001	0.10	6346.80	402.79	0.00
Coal Creek	Coal Creek	5350.99*	Average Annual	14.80	62.25	63.20	63.20	63.43	0.123646	3.80	3.90	8.65	1.00
Coal Creek	Coal Creek	5350.99*	Annual_98cfs	98.00	62.25	64.61	64.19	64.78	0.042191	3.36	29.17	24.54	0.54
Coal Creek	Coal Creek	5350.99*	1.25-yr_170cfs	170.00	62.25	65.39	64.56	65.57	0.027046	3.45	49.26	53.14	0.45
Coal Creek	Coal Creek	5350.99*	2-yr_234cfs	234.00	62.25	65.92	64.84	66.12	0.027936	3.57	65.58	76.35	0.44
Coal Creek	Coal Creek	5350.99*	5-yr_321cfs	321.00	62.25	66.57	65.18	66.78	0.022220	3.69	87.30	103.75	0.40
Coal Creek	Coal Creek	5350.99*	10-yr_379cfs	379.00	62.25	66.89	65.40	66.96	0.010614	2.35	186.02	118.04	0.26
Coal Creek	Coal Creek	5350.99*	25-yr_453cfs	453.00	62.25	67.88	65.70	67.92	0.003237	1.62	311.71	136.42	0.15
Coal Creek	Coal Creek	5350.99*	100-yr_565cfs	565.00	62.25	74.48	66.01	74.48	0.000028	0.31	1985.61	336.88	0.02
Coal Creek	Coal Creek	5350.99*	500-yr_698cfs	698.00	62.25	86.02	66.36	86.02	0.000001	0.11	6150.63	379.27	0.00
Coal Creek	Coal Creek	5319.381	Average Annual	14.80	61.11	62.39	61.82	62.42	0.004349	1.36	10.89	13.06	0.26
Coal Creek	Coal Creek	5319.381	Annual_98cfs	98.00	61.11	63.84	62.77	63.96	0.017153	2.76	35.46	20.02	0.37
Coal Creek	Coal Creek	5319.381	1.25-yr_170cfs	170.00	61.11	64.67	63.35	64.82	0.020621	3.03	56.05	26.15	0.37
Coal Creek	Coal Creek	5319.381	2-yr_234cfs	234.00	61.11	65.19	63.68	65.36	0.020344	3.36	69.63	33.41	0.37
Coal Creek	Coal Creek	5319.381	5-yr_321cfs	321.00	61.11	65.83	64.19	66.03	0.024872	3.62	88.78	53.61	0.39
Coal Creek	Coal Creek	5319.381	10-yr_379cfs	379.00	61.11	66.27	64.39	66.48	0.021821	3.67	103.40	58.52	0.37
Coal Creek	Coal Creek	5319.381	25-yr_453cfs	453.00	61.11	67.72	64.63	67.78	0.005814	2.00	243.82	99.09	0.18
Coal Creek	Coal Creek	5319.381	100-yr_565cfs	565.00	61.11	74.48	64.98	74.48	0.000043	0.35	1684.41	302.50	0.02
Coal Creek	Coal Creek	5319.381	500-yr_698cfs	698.00	61.11	86.02	65.36	86.02	0.000002	0.11	5554.74	358.43	0.00
Coal Creek	Coal Creek	5293.38*	Average Annual	14.80	61.36	62.29	61.90	62.31	0.003631	1.23	12.03	20.04	0.28
Coal Creek	Coal Creek	5293.38*	Annual_98cfs	98.00	61.36	63.62	62.60	63.71	0.005715	2.43	40.28	22.42	0.32
Coal Creek	Coal Creek	5293.38*	1.25-yr_170cfs	170.00	61.36	64.37	62.99	64.50	0.007871	2.93	58.00	24.88	0.34
Coal Creek	Coal Creek	5293.38*	2-yr_234cfs	234.00	61.36	64.85	63.30	65.02	0.009083	3.33	70.21	34.85	0.36
Coal Creek	Coal Creek	5293.38*	5-yr_321cfs	321.00	61.36	65.41	63.68	65.63	0.010495	3.78	84.93	48.16	0.38
Coal Creek	Coal Creek	5293.38*	10-yr_379cfs	379.00	61.36	65.79	63.90	66.03	0.014087	3.94	96.12	56.18	0.39
Coal Creek	Coal Creek	5293.38*	25-yr_453cfs	453.00	61.36	67.62	64.20	67.67	0.003088	2.05	260.62	97.00	0.18
Coal Creek	Coal Creek	5293.38*	100-yr_565cfs	565.00	61.36	74.48	64.57	7					

HEC-RAS Plan: HECdesign1 Locations: User Defined (Continued)

River	Reach	River Sta	Profile	Q Total	Min Ch El	W.S. Elev	Crit W.S.	E.G. Elev	E.G. Slope	Vel Chnl	Flow Area	Top Width	Froude # Chl
				(cfs)	(ft)	(ft)	(ft)	(ft)	(ft/ft)	(ft/s)	(sq ft)	(ft)	
Coal Creek	Coal Creek	5267.39*	Average Annual	14.80	60.85	62.19	61.63	62.22	0.003262	1.37	10.80	15.97	0.29
Coal Creek	Coal Creek	5267.39*	Annual_98cfs	98.00	60.85	63.40	62.59	63.53	0.008359	2.83	34.68	20.98	0.39
Coal Creek	Coal Creek	5267.39*	1.25-yr_170cfs	170.00	60.85	64.03	63.00	64.22	0.014696	3.53	48.13	23.94	0.44
Coal Creek	Coal Creek	5267.39*	2-yr_234cfs	234.00	60.85	64.46	63.32	64.71	0.016276	4.00	58.52	24.60	0.46
Coal Creek	Coal Creek	5267.39*	5-yr_321cfs	321.00	60.85	64.95	63.70	65.27	0.018347	4.54	70.74	48.85	0.48
Coal Creek	Coal Creek	5267.39*	10-yr_379cfs	379.00	60.85	65.21	63.93	65.58	0.020078	4.89	77.45	55.00	0.50
Coal Creek	Coal Creek	5267.39*	25-yr_453cfs	453.00	60.85	67.54	64.26	67.59	0.003025	1.95	271.65	101.84	0.17
Coal Creek	Coal Creek	5267.39*	100-yr_565cfs	565.00	60.85	74.48	64.63	74.48	0.000031	0.38	1818.63	315.68	0.02
Coal Creek	Coal Creek	5267.39*	500-yr_698cfs	698.00	60.85	86.02	65.03	86.02	0.000001	0.13	5674.49	350.46	0.00
Coal Creek	Coal Creek	5241.396	Average Annual	14.80	61.16	62.10	61.74	62.13	0.003670	1.39	10.65	18.91	0.33
Coal Creek	Coal Creek	5241.396	Annual_98cfs	98.00	61.16	63.17	62.49	63.30	0.009344	2.87	34.14	25.04	0.43
Coal Creek	Coal Creek	5241.396	1.25-yr_170cfs	170.00	61.16	63.66	62.90	63.86	0.013192	3.61	47.03	28.05	0.49
Coal Creek	Coal Creek	5241.396	2-yr_234cfs	234.00	61.16	64.05	63.21	64.30	0.014938	3.99	58.64	30.65	0.51
Coal Creek	Coal Creek	5241.396	5-yr_321cfs	321.00	61.16	64.51	63.56	64.81	0.016572	4.38	73.28	33.62	0.52
Coal Creek	Coal Creek	5241.396	10-yr_379cfs	379.00	61.16	64.76	63.78	65.09	0.016806	4.63	82.50	48.27	0.53
Coal Creek	Coal Creek	5241.396	25-yr_453cfs	453.00	61.16	67.51	64.03	67.55	0.000876	1.73	431.77	261.83	0.14
Coal Creek	Coal Creek	5241.396	100-yr_565cfs	565.00	61.16	74.48	64.37	74.48	0.000010	0.34	2508.59	310.96	0.02
Coal Creek	Coal Creek	5241.396	500-yr_698cfs	698.00	61.16	86.02	64.73	86.02	0.000001	0.15	6378.92	353.92	0.01
Coal Creek	Coal Creek	5211.09*	Average Annual	14.80	61.06	61.72	61.72	61.86	0.041252	2.94	5.03	19.55	1.02
Coal Creek	Coal Creek	5211.09*	Annual_98cfs	98.00	61.06	62.33	62.33	62.72	0.052441	4.99	19.65	25.75	1.01
Coal Creek	Coal Creek	5211.09*	1.25-yr_170cfs	170.00	61.06	62.95	62.68	63.29	0.027303	4.65	36.53	28.43	0.72
Coal Creek	Coal Creek	5211.09*	2-yr_234cfs	234.00	61.06	63.24	62.95	63.66	0.029711	5.22	44.79	29.64	0.75
Coal Creek	Coal Creek	5211.09*	5-yr_321cfs	321.00	61.06	63.61	63.27	64.12	0.030446	5.71	56.25	31.29	0.75
Coal Creek	Coal Creek	5211.09*	10-yr_379cfs	379.00	61.06	63.87	63.46	64.41	0.029729	5.88	64.42	32.44	0.74
Coal Creek	Coal Creek	5211.09*	25-yr_453cfs	453.00	61.06	67.47	63.69	67.52	0.001035	1.81	316.29	176.09	0.14
Coal Creek	Coal Creek	5211.09*	100-yr_565cfs	565.00	61.06	74.48	64.01	74.48	0.000011	0.33	2308.37	308.02	0.02
Coal Creek	Coal Creek	5211.09*	500-yr_698cfs	698.00	61.06	86.02	64.35	86.02	0.000001	0.15	6233.40	362.66	0.01
Coal Creek	Coal Creek	5180.79*	Average Annual	14.80	59.91	60.86	60.55	60.91	0.005193	1.80	8.24	14.77	0.42
Coal Creek	Coal Creek	5180.79*	Annual_98cfs	98.00	59.91	61.63	61.43	61.91	0.014331	4.24	23.13	24.20	0.76
Coal Creek	Coal Creek	5180.79*	1.25-yr_170cfs	170.00	59.91	62.22	61.87	62.49	0.024214	4.16	40.83	35.10	0.68
Coal Creek	Coal Creek	5180.79*	2-yr_234cfs	234.00	59.91	62.60	62.17	62.89	0.020000	4.29	54.51	36.94	0.62
Coal Creek	Coal Creek	5180.79*	5-yr_321cfs	321.00	59.91	63.10	62.45	63.39	0.016489	4.38	73.36	39.10	0.56
Coal Creek	Coal Creek	5180.79*	10-yr_379cfs	379.00	59.91	63.41	62.61	63.72	0.015027	4.41	85.94	40.56	0.53
Coal Creek	Coal Creek	5180.79*	25-yr_453cfs	453.00	59.91	67.49	62.81	67.50	0.000193	0.95	718.20	272.77	0.07
Coal Creek	Coal Creek	5180.79*	100-yr_565cfs	565.00	59.91	74.48	63.09	74.48	0.000004	0.23	2756.89	312.56	0.01
Coal Creek	Coal Creek	5180.79*	500-yr_698cfs	698.00	59.91	86.02	63.39	86.02	0.000000	0.11	6769.79	376.69	0.00
Coal Creek	Coal Creek	5150.487	Average Annual	14.80	60.05	60.62	60.48	60.65	0.015278	1.40	10.57	38.23	0.47
Coal Creek	Coal Creek	5150.487	Annual_98cfs	98.00	60.05	61.46	60.94	61.53	0.008064	2.09	46.85	46.70	0.37
Coal Creek	Coal Creek	5150.487	1.25-yr_170cfs	170.00	60.05	62.02	61.19	62.10	0.006387	2.31	73.71	49.69	0.33
Coal Creek	Coal Creek	5150.487	2-yr_234cfs	234.00	60.05	62.45	61.37	62.54	0.005499	2.45	95.62	51.02	0.32
Coal Creek	Coal Creek	5150.487	5-yr_321cfs	321.00	60.05	62.99	61.60	63.09	0.004804	2.60	123.36	52.41	0.30
Coal Creek	Coal Creek	5150.487	10-yr_379cfs	379.00	60.05	63.32	61.74	63.43	0.004510	2.69	140.87	53.23	0.29
Coal Creek	Coal Creek	5150.487	25-yr_453cfs	453.00	60.05	67.49	61.90	67.49	0.000095	0.63	857.42	265.47	0.04
Coal Creek	Coal Creek	5150.487	100-yr_565cfs	565.00	60.05	74.48	62.12	74.48	0.000003	0.19	2953.11	330.45	0.01
Coal Creek	Coal Creek	5150.487	500-yr_698cfs	698.00	60.05	86.02	62.37	86.02	0.000000	0.09	7217.98	392.98	0.00
Coal Creek	Coal Creek	5126.07*	Average Annual	14.80	59.53	59.94	59.94	60.08	0.037861	3.08	4.80	16.62	1.01
Coal Creek	Coal Creek	5126.07*	Annual_98cfs	98.00	59.53	60.64	60.64	61.11	0.041162	5.47	17.92	19.39	1.00
Coal Creek	Coal Creek	5126.07*	1.25-yr_170cfs	170.00	59.53	61.06	61.06	61.72	0.042010	6.50	26.15	19.98	1.00
Coal Creek	Coal Creek	5126.07*	2-yr_234cfs	234.00	59.53	61.38	61.38	62.18	0.042867	7.17	32.62	20.37	1.00
Coal Creek	Coal Creek	5126.07*	5-yr_321cfs	321.00	59.53	61.77	61.77	62.74	0.044333	7.90	40.64	20.90	1.00
Coal Creek	Coal Creek	5126.07*	10-yr_379cfs	379.00	59.53	62.00	62.00	63.08	0.045619	8.33	45.52	21.21	1.00
Coal Creek	Coal Creek	5126.07*	25-yr_453cfs	453.00	59.53	67.48	62.30	67.49	0.000173	0.84	808.33	295.17	0.06
Coal Creek	Coal Creek	5126.07*	100-yr_565cfs	565.00	59.53	74.48	62.72	74.48	0.000005	0.23	3076.91	360.69	0.01
Coal Creek	Coal Creek	5126.07*	500-yr_698cfs	698.00	59.53	86.02	63.14	86.02	0.000000	0.11	7836.78	424.20	0.00
Coal Creek	Coal Creek	5101.66*	Average Annual	14.80	55.30	56.66	56.04	56.68	0.001484	1.21	12.23	15.43	0.24
Coal Creek	Coal Creek	5101.66*	Annual_98cfs	98.00	55.30	56.34	56.97	58.88	0.246164	12.78	7.67	13.08	2.94
Coal Creek	Coal Creek	5101.66*	1.25-yr_170cfs	170.00	55.30	56.67	57.43	59.60	0.189175	13.73	12.38	15.51	2.71
Coal Creek	Coal Creek	5101.66*	2-yr_234cfs	234.00	55.30	56.91	57.76	60.10	0.166716	14.33	16.33	17.37	2.60
Coal Creek	Coal Creek	5101.66*	5-yr_321cfs	321.00	55.30	59.69	58.14	59.93	0.003504	3.94	81.40	28.91	0.41
Coal Creek	Coal Creek	5101.66*	10-yr_379cfs	379.00	55.30	62.61	58.38	62.68	0.000972	2.17	174.90	35.05	0.17
Coal Creek	Coal Creek	5101.66*	25-yr_453cfs	453.00	55.30	67.48	58.67	67.48	0.000084	0.76	995.27	397.14	0.05
Coal Creek	Coal Creek	5101.66*	100-yr_565cfs	565.00	55.30	74.48	59.06	74.48	0.000004	0.23	3946.72	434.66	0.01
Coal Creek	Coal Creek	5101.66*	500-yr_698cfs	698.00	55.30	86.02	59.47	86.02	0.000000	0.11	8994.40	437.69	0.00
Coal Creek	Coal Creek	5077.248	Average Annual	14.80	55.78	56.50	56.40	56.59	0.015065	2.40	6.16	16.06	0.68
Coal Creek	Coal Creek	5077.248	Annual_98cfs	98.00	55.78	57.14	57.14	57.59	0.025032	5.40	18.15	20.28	1.01
Coal Creek	Coal Creek	5077.248	1.25-yr_170cfs	170.00	55.78	57.55	57.55	58.18	0.022309	6.35	26.79	21.20	1.00
Coal Creek	Coal Creek	5077.248	2-yr_234cfs	234.00	55.78	57.85	57.85	58.62	0.021677	7.04	33.26	21.83	1.00
Coal Creek	Coal Creek	5077.248	5-yr_321cfs	321.00	55.78	59.53	58.24	59.83	0.004713	4.41	72.78	25.71	0.46
Coal Creek	Coal Creek	5077.248	10-yr_379cfs	379.00	55.78	62.58	58.46	62.66	0.001343	2.27	167.09	35.76	0.18
Coal Creek	Coal Creek	5077.248	25-yr_453cfs	453.00	55.78	67.48	58.73	67.48	0.000053	0.63	1297.51	387.05	0.04
Coal Creek	Coal Creek	5077.248	100-yr_565cfs	565.00	55.78	74.48	59.12	74.48	0.000003	0.22	4283.67	450.11	0.01
Coal Creek	Coal Creek	5077.248	500-yr_698cfs	698.00	55.78	86.02	59.54	86.02	0.000000	0.11	9488.28	451.17	0.00
Coal Creek	Coal Creek	5067.673	Average Annual	14.80	55.84	56.26	56.26	56.37	0.038503	2.71	5.47	24.02	1.00
Coal Creek	Coal Creek	5067.673	Annual_98cfs	98.00	55.84	56.70	56.82	57.2					

HEC-RAS Plan: HECdesign1 Locations: User Defined (Continued)

River	Reach	River Sta	Profile	Q Total	Min Ch El	W.S. Elev	Crit W.S.	E.G. Elev	E.G. Slope	Vel Chnl	Flow Area	Top Width	Froude # Chl
				(cfs)	(ft)	(ft)	(ft)	(ft)	(ft/ft)	(ft/s)	(sq ft)	(ft)	
Coal Creek	Coal Creek	5044.837	1.25-yr_170cfs	170.00	54.84	56.02	56.17	56.75	0.038034	6.85	24.82	26.38	1.24
Coal Creek	Coal Creek	5044.837	2-yr_234cfs	234.00	54.84	57.30	56.43	57.53	0.004425	3.83	61.02	30.14	0.47
Coal Creek	Coal Creek	5044.837	5-yr_321cfs-	321.00	54.84	59.62		59.70	0.001040	2.32	138.58	36.85	0.21
Coal Creek	Coal Creek	5044.837	10-yr_379cfs	379.00	54.84	62.60		62.62	0.000281	1.30	399.71	216.65	0.09
Coal Creek	Coal Creek	5044.837	25-yr_453cfs	453.00	54.84	67.48		67.48	0.000015	0.45	1911.52	340.07	0.02
Coal Creek	Coal Creek	5044.837	100-yr_565cfs	565.00	54.84	74.48		74.48	0.000002	0.23	4426.54	379.44	0.01
Coal Creek	Coal Creek	5044.837	500-yr_698cfs	698.00	54.84	86.02		86.02	0.000000	0.14	9086.65	425.40	0.00
Coal Creek	Coal Creek	5022.706	Average Annual	14.80	53.84	54.49	54.26	54.52	0.003657	1.32	11.24	24.75	0.34
Coal Creek	Coal Creek	5022.706	Annual_98cfs	98.00	53.84	55.51	54.82	55.61	0.003320	2.58	38.01	27.81	0.39
Coal Creek	Coal Creek	5022.706	1.25-yr_170cfs	170.00	53.84	56.15	55.17	56.29	0.002955	3.01	56.47	29.70	0.38
Coal Creek	Coal Creek	5022.706	2-yr_234cfs	234.00	53.84	57.35		57.44	0.001350	2.49	94.04	33.19	0.26
Coal Creek	Coal Creek	5022.706	5-yr_321cfs-	321.00	53.84	59.62		59.67	0.000625	1.81	184.05	69.54	0.15
Coal Creek	Coal Creek	5022.706	10-yr_379cfs	379.00	53.84	62.60		62.62	0.000131	0.99	660.78	285.49	0.07
Coal Creek	Coal Creek	5022.706	25-yr_453cfs	453.00	53.84	67.48		67.48	0.000010	0.38	2254.44	345.62	0.02
Coal Creek	Coal Creek	5022.706	100-yr_565cfs	565.00	53.84	74.48		74.48	0.000002	0.22	4809.26	386.01	0.01
Coal Creek	Coal Creek	5022.706	500-yr_698cfs	698.00	53.84	86.02		86.02	0.000000	0.13	9513.68	427.60	0.00
Coal Creek	Coal Creek	5002.2	Average Annual	14.80	53.73	54.18	54.18	54.34	0.036113	3.17	4.67	15.33	1.01
Coal Creek	Coal Creek	5002.2	Annual_98cfs	98.00	53.73	54.95	54.95	55.43	0.025062	5.57	17.58	18.49	1.01
Coal Creek	Coal Creek	5002.2	1.25-yr_170cfs	170.00	53.73	55.88		56.18	0.008556	4.45	43.53	44.07	0.63
Coal Creek	Coal Creek	5002.2	2-yr_234cfs	234.00	53.73	57.34		57.40	0.002290	2.18	148.23	84.69	0.25
Coal Creek	Coal Creek	5002.2	5-yr_321cfs-	321.00	53.73	59.64		59.65	0.000436	1.08	371.64	109.52	0.10
Coal Creek	Coal Creek	5002.2	10-yr_379cfs	379.00	53.73	62.61		62.61	0.000089	0.61	786.82	180.66	0.04
Coal Creek	Coal Creek	5002.2	25-yr_453cfs	453.00	53.73	67.48		67.48	0.000012	0.34	1983.10	270.66	0.02
Coal Creek	Coal Creek	5002.2	100-yr_565cfs	565.00	53.73	74.48		74.48	0.000002	0.21	4009.14	304.27	0.01
Coal Creek	Coal Creek	5002.2	500-yr_698cfs	698.00	53.73	86.02		86.02	0.000000	0.13	7776.59	347.32	0.00
Coal Creek	Coal Creek	4975.96	Average Annual	14.80	52.73	53.17	53.18	53.34	0.040083	3.27	4.52	15.29	1.06
Coal Creek	Coal Creek	4975.96	Annual_98cfs	98.00	52.73	53.75	53.94	54.51	0.049345	6.96	14.07	17.69	1.38
Coal Creek	Coal Creek	4975.96	1.25-yr_170cfs	170.00	52.73	55.98		56.04	0.001233	2.09	118.57	80.68	0.25
Coal Creek	Coal Creek	4975.96	2-yr_234cfs	234.00	52.73	57.34		57.36	0.000582	1.37	238.14	95.46	0.14
Coal Creek	Coal Creek	4975.96	5-yr_321cfs-	321.00	52.73	59.63		59.64	0.000191	0.84	487.11	125.88	0.07
Coal Creek	Coal Creek	4975.96	10-yr_379cfs	379.00	52.73	62.61		62.61	0.000046	0.54	984.67	220.69	0.04
Coal Creek	Coal Creek	4975.96	25-yr_453cfs	453.00	52.73	67.48		67.48	0.000008	0.31	2256.56	276.56	0.02
Coal Creek	Coal Creek	4975.96	100-yr_565cfs	565.00	52.73	74.48		74.48	0.000002	0.20	4315.34	308.16	0.01
Coal Creek	Coal Creek	4975.96	500-yr_698cfs	698.00	52.73	86.02		86.02	0.000000	0.14	8124.90	349.31	0.00
Coal Creek	Coal Creek	4954.856	Average Annual	14.80	51.73	52.14	52.18	52.35	0.055529	3.62	4.09	15.18	1.23
Coal Creek	Coal Creek	4954.856	Annual_98cfs	98.00	51.73	54.24	52.95	54.30	0.001470	2.00	62.98	70.14	0.27
Coal Creek	Coal Creek	4954.856	1.25-yr_170cfs	170.00	51.73	55.99		56.01	0.000313	1.24	206.22	91.78	0.13
Coal Creek	Coal Creek	4954.856	2-yr_234cfs	234.00	51.73	57.34		57.35	0.000157	0.83	339.11	106.26	0.10
Coal Creek	Coal Creek	4954.856	5-yr_321cfs-	321.00	51.73	59.63		59.64	0.000056	0.78	625.87	152.13	0.06
Coal Creek	Coal Creek	4954.856	10-yr_379cfs	379.00	51.73	62.60		62.61	0.000016	0.57	1227.94	253.89	0.04
Coal Creek	Coal Creek	4954.856	25-yr_453cfs	453.00	51.73	67.48		67.48	0.000003	0.35	2536.29	283.13	0.02
Coal Creek	Coal Creek	4954.856	100-yr_565cfs	565.00	51.73	74.48		74.48	0.000001	0.25	4625.37	312.05	0.01
Coal Creek	Coal Creek	4954.856	500-yr_698cfs	698.00	51.73	86.02		86.02	0.000000	0.18	8475.06	350.65	0.01
Coal Creek	Coal Creek	4933.66	Average Annual	14.80	50.73	52.06	51.18	52.07	0.000400	0.75	19.78	18.98	0.13
Coal Creek	Coal Creek	4933.66	Annual_98cfs	98.00	50.73	54.26		54.28	0.000267	1.02	141.91	83.88	0.12
Coal Creek	Coal Creek	4933.66	1.25-yr_170cfs	170.00	50.73	56.00		56.01	0.000112	0.83	303.76	102.61	0.08
Coal Creek	Coal Creek	4933.66	2-yr_234cfs	234.00	50.73	57.34		57.35	0.000070	0.77	451.03	117.91	0.07
Coal Creek	Coal Creek	4933.66	5-yr_321cfs-	321.00	50.73	59.63		59.64	0.000030	0.64	791.93	181.77	0.05
Coal Creek	Coal Creek	4933.66	10-yr_379cfs	379.00	50.73	62.61		62.61	0.000010	0.48	1485.56	260.30	0.03
Coal Creek	Coal Creek	4933.66	25-yr_453cfs	453.00	50.73	67.48		67.48	0.000002	0.32	2822.44	288.80	0.02
Coal Creek	Coal Creek	4933.66	100-yr_565cfs	565.00	50.73	74.48		74.48	0.000001	0.24	4939.38	315.94	0.01
Coal Creek	Coal Creek	4933.66	500-yr_698cfs	698.00	50.73	86.02		86.02	0.000000	0.17	8825.71	350.65	0.01
Coal Creek	Coal Creek	4914.324	Average Annual	14.80	50.73	52.06		52.06	0.000410	0.75	19.63	18.95	0.13
Coal Creek	Coal Creek	4914.324	Annual_98cfs	98.00	50.73	54.26		54.27	0.000213	0.91	141.71	83.86	0.11
Coal Creek	Coal Creek	4914.324	1.25-yr_170cfs	170.00	50.73	56.00		56.00	0.000080	0.70	303.75	102.61	0.07
Coal Creek	Coal Creek	4914.324	2-yr_234cfs	234.00	50.73	57.34		57.34	0.000049	0.64	451.07	117.91	0.06
Coal Creek	Coal Creek	4914.324	5-yr_321cfs-	321.00	50.73	59.64		59.64	0.000021	0.53	792.03	181.80	0.04
Coal Creek	Coal Creek	4914.324	10-yr_379cfs	379.00	50.73	62.61		62.61	0.000007	0.39	1485.70	260.31	0.02
Coal Creek	Coal Creek	4914.324	25-yr_453cfs	453.00	50.73	67.48		67.48	0.000001	0.25	2822.51	288.80	0.01
Coal Creek	Coal Creek	4914.324	100-yr_565cfs	565.00	50.73	74.48		74.48	0.000000	0.18	4939.42	315.94	0.01
Coal Creek	Coal Creek	4914.324	500-yr_698cfs	698.00	50.73	86.02		86.02	0.000000	0.12	8825.74	350.65	0.00
Coal Creek	Coal Creek	4908.637	Average Annual	14.80	50.90	51.88	51.88	52.04	0.033953	3.24	4.57	12.87	0.96
Coal Creek	Coal Creek	4908.637	Annual_98cfs	98.00	50.90	54.23		54.27	0.000681	1.51	67.79	42.90	0.18
Coal Creek	Coal Creek	4908.637	1.25-yr_170cfs	170.00	50.90	55.98		56.00	0.000233	1.19	181.75	97.25	0.12
Coal Creek	Coal Creek	4908.637	2-yr_234cfs	234.00	50.90	57.33		57.34	0.000102	1.00	321.85	110.97	0.08
Coal Creek	Coal Creek	4908.637	5-yr_321cfs-	321.00	50.90	59.63		59.64	0.000035	0.76	599.42	127.55	0.05
Coal Creek	Coal Creek	4908.637	10-yr_379cfs	379.00	50.90	62.60		62.61	0.000011	0.56	1002.47	145.03	0.03
Coal Creek	Coal Creek	4908.637	25-yr_453cfs	453.00	50.90	67.48		67.48	0.000003	0.40	1814.32	216.34	0.02
Coal Creek	Coal Creek	4908.637	100-yr_565cfs	565.00	50.90	74.48		74.48	0.000001	0.27	3488.97	257.88	0.01
Coal Creek	Coal Creek	4908.637	500-yr_698cfs	698.00	50.90	86.02		86.02	0.000000	0.18	7679.81	308.55	0.01
Coal Creek	Coal Creek	4903.362	Average Annual	14.80	47.00	51.51	47.50	51.51	0.000027	0.40	37.94	9.46	0.03
Coal Creek	Coal Creek	4903.362	Annual_98cfs	98.00	47.00	54.24		54.26	0.000150	0.94	109.83	43.67	0.09
Coal Creek	Coal Creek	4903.362	1.25-yr_170cfs	170.00	47.00	55.99		56.00	0.000108	0.95	224.44	97.81	0.08
Coal Creek	Coal Creek	4903.362	2-yr_234cfs	234.00	47.00	57.33		57.34	0.000063	0.87	364.82	111.33	0.06
Coal Creek	Coal Creek	4903.362	5-yr_321cfs-	321.00	47.00	59.63		59.64	0.000027	0.71	642.93	127.76	0.04
Coal Creek	Coal Creek	4903.362	10-yr_379cfs	379.00	47.00	62.60		62.61	0.000010	0.53	1046.31	145.05	0.03
Coal Creek	Coal Creek	4903.362	25-yr_453cfs	453.00	47.00	67.48		67.48	0.000003	0.39	1858.16	216.34	0.02
Coal Creek	Coal Creek	4903.362	100-yr_565cfs	565.00	47.00	74.48		74.48	0.000001	0.27	3532.81	257.88	0.01
Coal Creek	Coal Creek	4903.362	500-yr_698cfs	698.00	47.00	86.02		86.02	0.000000	0.18	6813.65	308.55	0.01
Coal Creek	Coal Creek	4897.104	Average Annual	14.80	47.00	51.51	47.49	51.51	0.000021	0.37	44.57	12.49	0.03
Coal Creek	Coal Creek	4897.104	Annual_98cfs	98.00	47.00	54.23	48.71	54.26	0.000158	1.44	80.10	48.22	0.10
Coal Creek	Coal Creek	4897.104	1.25-yr_170cfs	170.00	47.00	55.94	49.44	55.99	0.000216	1.95	103.26	102.51	0.12
Coal Creek	Coal Creek	4897.104	2-yr_234cfs	234.00	47.00	57.26	49.98	57.33	0.000247	2.29	121.09	113.32	0.13
Coal Creek	Coal Creek	4897.104	5-yr_321cfs-	321.00	47.00	59.54	50.62						

HEC-RAS Plan: HECdesign1 Locations: User Defined (Continued)

River	Reach	River Sta	Profile	Q Total (cfs)	Min Ch El (ft)	W.S. Elev (ft)	Crit W.S. (ft)	E.G. Elev (ft)	E.G. Slope (ft/ft)	Vel Chnl (ft/s)	Flow Area (sq ft)	Top Width (ft)	Froude # Chl
Coal Creek	Coal Creek	4897.104	10-yr_379cfs	379.00	47.00	62.53	51.01	62.60	0.000147	2.35	192.15	144.84	0.11
Coal Creek	Coal Creek	4897.104	25-yr_453cfs	453.00	47.00	67.42	51.46	67.47	0.000110	2.01	273.96	215.93	0.09
Coal Creek	Coal Creek	4897.104	100-yr_565cfs	565.00	47.00	74.48	52.10	74.48	0.000012	0.58	1642.02	257.87	0.03
Coal Creek	Coal Creek	4897.104	500-yr_698cfs	698.00	47.00	86.01	52.82	86.02	0.000001	0.23	4923.45	308.55	0.01
Coal Creek	Coal Creek	4892	Inl Struct										
Coal Creek	Coal Creek	4887.114	Average Annual	14.80	47.20	51.50		51.50	0.000010	0.23	64.49	15.00	0.02
Coal Creek	Coal Creek	4887.114	Annual_98cfs	98.00	47.20	54.07		54.09	0.000119	0.95	103.08	15.00	0.06
Coal Creek	Coal Creek	4887.114	1.25-yr_170cfs	170.00	47.20	55.64		55.67	0.000208	1.34	126.63	15.00	0.08
Coal Creek	Coal Creek	4887.114	2-yr_234cfs	234.00	47.20	56.84		56.88	0.000279	1.62	144.56	15.00	0.09
Coal Creek	Coal Creek	4887.114	5-yr_321cfs-	321.00	47.20	59.07		59.12	0.000308	1.80	178.12	15.00	0.09
Coal Creek	Coal Creek	4887.114	10-yr_379cfs	379.00	47.20	61.98		62.02	0.000249	1.71	221.64	15.00	0.08
Coal Creek	Coal Creek	4887.114	25-yr_453cfs	453.00	47.20	66.41		66.45	0.000189	1.57	288.14	15.00	0.06
Coal Creek	Coal Creek	4887.114	100-yr_565cfs	565.00	47.20	74.43		74.46	0.000131	1.38	408.42	15.00	0.05
Coal Creek	Coal Creek	4887.114	500-yr_698cfs	698.00	47.20	85.98		86.00	0.000090	1.20	581.67	15.00	0.03
Coal Creek	Coal Creek	4885	Average Annual	14.80	47.20	51.50		51.50	0.000010	0.23	64.49	15.00	0.02
Coal Creek	Coal Creek	4885	Annual_98cfs	98.00	47.20	54.07		54.09	0.000119	0.95	103.08	15.00	0.06
Coal Creek	Coal Creek	4885	1.25-yr_170cfs	170.00	47.20	55.64		55.67	0.000208	1.34	126.63	15.00	0.08
Coal Creek	Coal Creek	4885	2-yr_234cfs	234.00	47.20	56.84		56.88	0.000279	1.62	144.55	15.00	0.09
Coal Creek	Coal Creek	4885	5-yr_321cfs-	321.00	47.20	59.07		59.12	0.000308	1.80	178.11	15.00	0.09
Coal Creek	Coal Creek	4885	10-yr_379cfs	379.00	47.20	61.98		62.02	0.000250	1.71	221.64	15.00	0.08
Coal Creek	Coal Creek	4885	25-yr_453cfs	453.00	47.20	66.41		66.45	0.000189	1.57	288.14	15.00	0.06
Coal Creek	Coal Creek	4885	100-yr_565cfs	565.00	47.20	74.43		74.46	0.000131	1.38	408.41	15.00	0.05
Coal Creek	Coal Creek	4885	500-yr_698cfs	698.00	47.20	85.98		86.00	0.000090	1.20	581.67	15.00	0.03
Coal Creek	Coal Creek	4883	Average Annual	14.80	47.20	51.50		51.50	0.000010	0.23	64.49	15.00	0.02
Coal Creek	Coal Creek	4883	Annual_98cfs	98.00	47.20	54.07		54.09	0.000119	0.95	103.08	15.00	0.06
Coal Creek	Coal Creek	4883	1.25-yr_170cfs	170.00	47.20	55.64		55.67	0.000208	1.34	126.62	15.00	0.08
Coal Creek	Coal Creek	4883	2-yr_234cfs	234.00	47.20	56.84		56.88	0.000279	1.62	144.54	15.00	0.09
Coal Creek	Coal Creek	4883	5-yr_321cfs-	321.00	47.20	59.07		59.12	0.000308	1.80	178.10	15.00	0.09
Coal Creek	Coal Creek	4883	10-yr_379cfs	379.00	47.20	61.98		62.02	0.000250	1.71	221.63	15.00	0.08
Coal Creek	Coal Creek	4883	25-yr_453cfs	453.00	47.20	66.41		66.45	0.000189	1.57	288.13	15.00	0.06
Coal Creek	Coal Creek	4883	100-yr_565cfs	565.00	47.20	74.43		74.46	0.000131	1.38	408.41	15.00	0.05
Coal Creek	Coal Creek	4883	500-yr_698cfs	698.00	47.20	85.98		86.00	0.000090	1.20	581.67	15.00	0.03
Coal Creek	Coal Creek	4881	Average Annual	14.80	47.20	51.50		51.50	0.000010	0.23	64.49	15.00	0.02
Coal Creek	Coal Creek	4881	Annual_98cfs	98.00	47.20	54.07		54.09	0.000119	0.95	103.08	15.00	0.06
Coal Creek	Coal Creek	4881	1.25-yr_170cfs	170.00	47.20	55.64		55.67	0.000208	1.34	126.61	15.00	0.08
Coal Creek	Coal Creek	4881	2-yr_234cfs	234.00	47.20	56.84		56.88	0.000279	1.62	144.53	15.00	0.09
Coal Creek	Coal Creek	4881	5-yr_321cfs-	321.00	47.20	59.07		59.12	0.000308	1.80	178.09	15.00	0.09
Coal Creek	Coal Creek	4881	10-yr_379cfs	379.00	47.20	61.97		62.02	0.000250	1.71	221.62	15.00	0.08
Coal Creek	Coal Creek	4881	25-yr_453cfs	453.00	47.20	66.41		66.45	0.000189	1.57	288.13	15.00	0.06
Coal Creek	Coal Creek	4881	100-yr_565cfs	565.00	47.20	74.43		74.46	0.000131	1.38	408.40	15.00	0.05
Coal Creek	Coal Creek	4881	500-yr_698cfs	698.00	47.20	85.98		86.00	0.000090	1.20	581.66	15.00	0.03
Coal Creek	Coal Creek	4864.693	Average Annual	14.80	47.20	51.50	47.56	51.50	0.000009	0.29	51.59	15.00	0.02
Coal Creek	Coal Creek	4864.693	Annual_98cfs	98.00	47.20	54.06	48.47	54.08	0.000079	1.19	82.35	15.00	0.08
Coal Creek	Coal Creek	4864.693	1.25-yr_170cfs	170.00	47.20	55.62	49.03	55.67	0.000120	1.68	101.08	15.00	0.10
Coal Creek	Coal Creek	4864.693	2-yr_234cfs	234.00	47.20	56.81	49.47	56.87	0.000146	2.03	115.32	15.00	0.12
Coal Creek	Coal Creek	4864.693	5-yr_321cfs-	321.00	47.20	59.04	50.00	59.12	0.000137	2.26	142.09	15.00	0.12
Coal Creek	Coal Creek	4864.693	10-yr_379cfs	379.00	47.20	61.95	50.33	62.02	0.000092	2.14	176.95	15.00	0.10
Coal Creek	Coal Creek	4864.693	25-yr_453cfs	453.00	47.20	66.38	50.72	66.44	0.000055	1.97	230.21	15.00	0.08
Coal Creek	Coal Creek	4864.693	100-yr_565cfs	565.00	47.20	74.41	51.28	74.45	0.000027	1.73	326.50	15.00	0.06
Coal Creek	Coal Creek	4864.693	500-yr_698cfs	698.00	47.20	85.96	51.90	86.00	0.000012	1.50	465.16	15.00	0.04
Coal Creek	Coal Creek	4650	I-405										
Coal Creek	Coal Creek	4393.951	Average Annual	14.80	45.16	46.25	45.72	46.27	0.002768	1.31	11.30	14.05	0.26
Coal Creek	Coal Creek	4393.951	Annual_98cfs	98.00	45.16	47.55	46.60	47.71	0.005028	3.23	30.79	15.87	0.40
Coal Creek	Coal Creek	4393.951	1.25-yr_170cfs	170.00	45.16	48.25	47.10	48.52	0.005627	4.15	42.27	16.79	0.44
Coal Creek	Coal Creek	4393.951	2-yr_234cfs	234.00	45.16	48.78	47.49	49.13	0.005913	4.78	51.31	17.85	0.46
Coal Creek	Coal Creek	4393.951	5-yr_321cfs-	321.00	45.16	49.40	47.96	49.85	0.006172	5.47	62.92	19.93	0.49
Coal Creek	Coal Creek	4393.951	10-yr_379cfs	379.00	45.16	49.76	48.25	50.28	0.006308	5.87	70.39	55.42	0.50
Coal Creek	Coal Creek	4393.951	25-yr_453cfs	453.00	45.16	50.18	48.58	50.77	0.006439	6.31	79.63	67.97	0.51
Coal Creek	Coal Creek	4393.951	100-yr_565cfs	565.00	45.16	50.75	49.10	51.45	0.006583	6.89	92.49	68.33	0.53
Coal Creek	Coal Creek	4393.951	500-yr_698cfs	698.00	45.16	51.35	49.66	52.17	0.006796	7.52	106.07	68.71	0.55

ATTACHMENT E

HEC-RAS Locations: User Defined Profile: 100-Year 565 cfs

HEC-RAS Locations: User Defined Profile: 100-yr_565cfs

River	Reach	River Sta	Profile	Plan	Q Total (cfs)	Min Ch El (ft)	W.S. Elev (ft)	Crit W.S. (ft)	E.G. Elev (ft)	E.G. Slope (ft/ft)	Vel Chnl (ft/s)	Flow Area (sq ft)	Top Width (ft)	Froude # Chl
Coal Creek	Coal Creek	7602.644	100-yr_565cfs	HECdesign1	565.00	91.29	95.01	95.01	96.07	0.018853	8.28	68.34	33.10	1.00
Coal Creek	Coal Creek	7602.644	100-yr_565cfs	HECexist1	565.00	91.29	95.01	95.01	96.07	0.018853	8.28	68.34	33.10	1.00
Coal Creek	Coal Creek	7252.914	100-yr_565cfs	HECdesign1	565.00	86.23	89.94	89.47	90.49	0.009834	5.97	94.67	45.20	0.73
Coal Creek	Coal Creek	7252.914	100-yr_565cfs	HECexist1	565.00	86.23	89.94	89.47	90.49	0.009834	5.97	94.67	45.20	0.73
Coal Creek	Coal Creek	7034.648	100-yr_565cfs	HECdesign1	565.00	84.00	86.56	86.56	87.50	0.019702	7.78	72.58	38.92	1.00
Coal Creek	Coal Creek	7034.648	100-yr_565cfs	HECexist1	565.00	84.00	86.56	86.56	87.50	0.019702	7.78	72.58	38.92	1.00
Coal Creek	Coal Creek	6903.79*	100-yr_565cfs	HECdesign1	565.00	82.00	84.96	84.41	85.51	0.009156	5.97	94.68	42.69	0.71
Coal Creek	Coal Creek	6903.79*	100-yr_565cfs	HECexist1	565.00	82.00	84.96	84.41	85.51	0.009156	5.97	94.68	42.69	0.71
Coal Creek	Coal Creek	6772.943	100-yr_565cfs	HECdesign1	565.00	80.00	82.74	82.74	83.80	0.018810	8.25	69.13	36.44	1.00
Coal Creek	Coal Creek	6772.943	100-yr_565cfs	HECexist1	565.00	80.00	82.74	82.74	83.80	0.018810	8.25	69.13	36.44	1.00
Coal Creek	Coal Creek	6643.38*	100-yr_565cfs	HECdesign1	565.00	77.19	80.19	80.32	81.09	0.022634	7.69	82.52	71.27	1.06
Coal Creek	Coal Creek	6643.38*	100-yr_565cfs	HECexist1	565.00	77.19	80.19	80.32	81.09	0.022634	7.69	82.52	71.27	1.06
Coal Creek	Coal Creek	6513.829	100-yr_565cfs	HECdesign1	565.00	74.01	78.03	77.20	78.64	0.007567	6.25	90.39	31.59	0.65
Coal Creek	Coal Creek	6513.829	100-yr_565cfs	HECexist1	565.00	74.01	78.03	77.20	78.64	0.007567	6.25	90.40	31.59	0.65
Coal Creek	Coal Creek	6386.04*	100-yr_565cfs	HECdesign1	565.00	73.46	77.56		77.91	0.003681	4.86	143.43	81.96	0.47
Coal Creek	Coal Creek	6386.04*	100-yr_565cfs	HECexist1	565.00	73.46	77.56		77.91	0.003681	4.86	143.44	81.96	0.47
Coal Creek	Coal Creek	6258.266	100-yr_565cfs	HECdesign1	565.00	72.31	76.90		77.13	0.010472	4.27	177.04	102.22	0.42
Coal Creek	Coal Creek	6258.266	100-yr_565cfs	HECexist1	565.00	72.31	76.90		77.13	0.010470	4.27	177.05	102.22	0.42
Coal Creek	Coal Creek	6140.08*	100-yr_565cfs	HECdesign1	565.00	71.55	75.71		76.01	0.008618	4.83	175.80	115.18	0.45
Coal Creek	Coal Creek	6140.08*	100-yr_565cfs	HECexist1	565.00	71.55	75.71		76.01	0.008624	4.83	175.74	115.16	0.45
Coal Creek	Coal Creek	6021.9	100-yr_565cfs	HECdesign1	565.00	69.97	74.61		74.93	0.009696	4.76	159.93	113.02	0.44
Coal Creek	Coal Creek	6021.9	100-yr_565cfs	HECexist1	565.00	69.97	74.57		74.90	0.010139	4.83	155.80	109.69	0.45
Coal Creek	Coal Creek	5960.99*	100-yr_565cfs	HECdesign1	565.00	67.30	74.62		74.70	0.001145	2.41	365.06	155.15	0.18
Coal Creek	Coal Creek	5960.99*	100-yr_565cfs	HECexist1	565.00	67.30	74.59		74.67	0.001180	2.43	359.82	154.12	0.18
Coal Creek	Coal Creek	5900.08	100-yr_565cfs	HECdesign1	565.00	67.79	74.59	71.47	74.62	0.000921	1.96	502.48	189.97	0.15
Coal Creek	Coal Creek	5900.08	100-yr_565cfs	HECexist1	565.00	67.79	74.55	71.47	74.59	0.000954	1.99	495.75	189.76	0.15
Coal Creek	Coal Creek	5840.97*	100-yr_565cfs	HECdesign1	565.00	67.69	74.56		74.58	0.000472	1.59	575.88	176.25	0.11
Coal Creek	Coal Creek	5840.97*	100-yr_565cfs	HECexist1	565.00	67.69	74.52		74.55	0.000487	1.61	569.47	176.12	0.12
Coal Creek	Coal Creek	5781.861	100-yr_565cfs	HECdesign1	565.00	66.58	74.54		74.55	0.000449	0.75	664.68	175.10	0.05
Coal Creek	Coal Creek	5781.861	100-yr_565cfs	HECexist1	565.00	66.22	74.51		74.52	0.000236	1.17	692.33	174.77	0.08
Coal Creek	Coal Creek	5730.79*	100-yr_565cfs	HECdesign1	565.00	65.84	74.52		74.53	0.000509	0.85	691.89	173.35	0.06
Coal Creek	Coal Creek	5730.79*	100-yr_565cfs	HECexist1	565.00	65.54	74.50		74.51	0.000206	1.19	729.17	173.14	0.08
Coal Creek	Coal Creek	5679.72*	100-yr_565cfs	HECdesign1	565.00	65.06	74.50		74.51	0.000235	0.75	906.46	193.94	0.05
Coal Creek	Coal Creek	5679.72*	100-yr_565cfs	HECexist1	565.00	65.06	74.49		74.50	0.000141	0.98	925.02	193.90	0.06
Coal Creek	Coal Creek	5628.661	100-yr_565cfs	HECdesign1	565.00	65.26	74.49		74.50	0.000098	0.43	919.31	195.17	0.03
Coal Creek	Coal Creek	5628.661	100-yr_565cfs	HECexist1	565.00	65.25	74.49		74.50	0.000066	0.68	949.85	195.12	0.04
Coal Creek	Coal Creek	5592.64*	100-yr_565cfs	HECdesign1	565.00	64.32	74.49		74.50	0.000054	0.30	1099.24	203.25	0.02
Coal Creek	Coal Creek	5592.64*	100-yr_565cfs	HECexist1	565.00	64.32	74.49		74.49	0.000040	0.48	1129.12	203.24	0.03
Coal Creek	Coal Creek	5556.62*	100-yr_565cfs	HECdesign1	565.00	64.83	74.49	68.31	74.49	0.000130	0.59	1147.18	228.43	0.04
Coal Creek	Coal Creek	5556.62*	100-yr_565cfs	HECexist1	565.00	64.83	74.49	67.64	74.49	0.000083	0.73	1174.99	228.41	0.04
Coal Creek	Coal Creek	5520.611	100-yr_565cfs	HECdesign1	565.00	64.44	74.49	67.28	74.49	0.000051	0.62	1415.34	246.22	0.04
Coal Creek	Coal Creek	5520.611	100-yr_565cfs	HECexist1	565.00	64.44	74.49	67.28	74.49	0.000051	0.62	1414.97	246.21	0.04
Coal Creek	Coal Creek	5485.14*	100-yr_565cfs	HECdesign1	565.00	64.18	74.49	68.21	74.49	0.000053	0.36	1531.21	263.88	0.02
Coal Creek	Coal Creek	5485.14*	100-yr_565cfs	HECexist1	565.00	64.11	74.49	67.13	74.49	0.000040	0.54	1559.21	263.87	0.03
Coal Creek	Coal Creek	5449.67*	100-yr_565cfs	HECdesign1	565.00	62.32	74.49	66.07	74.49	0.000030	0.46	1736.42	290.45	0.03
Coal Creek	Coal Creek	5449.67*	100-yr_565cfs	HECexist1	565.00	62.32	74.48	66.07	74.49	0.000030	0.46	1736.09	290.44	0.03
Coal Creek	Coal Creek	5414.208	100-yr_565cfs	HECdesign1	565.00	62.35	74.48	65.69	74.49	0.000029	0.47	1840.94	346.87	0.03
Coal Creek	Coal Creek	5414.208	100-yr_565cfs	HECexist1	565.00	62.35	74.48	65.69	74.49	0.000029	0.47	1840.55	346.85	0.03
Coal Creek	Coal Creek	5382.59*	100-yr_565cfs	HECdesign1	565.00	61.82	74.48	66.81	74.49	0.000038	0.31	1893.36	361.61	0.02
Coal Creek	Coal Creek	5382.59*	100-yr_565cfs	HECexist1	565.00	61.82	74.48	65.64	74.48	0.000027	0.45	1925.80	361.61	0.02
Coal Creek	Coal Creek	5350.99*	100-yr_565cfs	HECdesign1	565.00	62.25	74.48	66.01	74.48	0.000028	0.31	1985.61	336.88	0.02
Coal Creek	Coal Creek	5350.99*	100-yr_565cfs	HECexist1	565.00	62.09	74.48	65.48	74.48	0.000022	0.41	2009.70	336.87	0.02
Coal Creek	Coal Creek	5319.381	100-yr_565cfs	HECdesign1	565.00	61.11	74.48	64.98	74.48	0.000043	0.35	1684.41	302.50	0.02
Coal Creek	Coal Creek	5319.381	100-yr_565cfs	HECexist1	565.00	61.11	74.48	64.61	74.48	0.000029	0.47	1714.91	302.49	0.02
Coal Creek	Coal Creek	5293.38*	100-yr_565cfs	HECdesign1	565.00	61.36	74.48	64.57	74.48	0.000039	0.44	1669.68	313.74	0.02
Coal Creek	Coal Creek	5293.38*	100-yr_565cfs	HECexist1	565.00	61.36	74.48	64.50	74.48	0.000030	0.51	1681.55	313.74	0.03
Coal Creek	Coal Creek	5267.39*	100-yr_565cfs	HECdesign1	565.00	60.85	74.48	64.63	74.48	0.000031	0.38	1818.63	315.68	0.02
Coal Creek	Coal Creek	5267.39*	100-yr_565cfs	HECexist1	565.00	60.85	74.48	64.53	74.48	0.000024	0.47	1835.65	315.68	0.02
Coal Creek	Coal Creek	5241.396	100-yr_565cfs	HECdesign1	565.00	61.16	74.48	64.37	74.48	0.000010	0.34	2508.59	310.96	0.02
Coal Creek	Coal Creek	5241.396	100-yr_565cfs	HECexist1	565.00	61.16	74.48	64.37	74.48	0.000010	0.34	2508.59	310.96	0.02
Coal Creek	Coal Creek	5211.09*	100-yr_565cfs	HECdesign1	565.00	61.06	74.48	64.01	74.48	0.000011	0.33	2308.37	308.02	0.02
Coal Creek	Coal Creek	5211.09*	100-yr_565cfs	HECexist1	565.00	61.06	74.48	64.01	74.48	0.000011	0.33	2308.37	308.02	0.02
Coal Creek	Coal Creek	5180.79*	100-yr_565cfs	HECdesign1	565.00	59.91	74.48	63.09	74.48	0.000004	0.23	2756.89	312.56	0.01
Coal Creek	Coal Creek	5180.79*	100-yr_565cfs	HECexist1	565.00	59.91	74.48	63.09	74.48	0.000004	0.23	2756.89	312.56	0.01
Coal Creek	Coal Creek	5150.487	100-yr_565cfs	HECdesign1	565.00	60.05	74.48	62.12	74.48	0.000003	0.19	2953.11	330.45	0.01

HEC-RAS Locations: User Defined Profile: 100-yr_565cfs (Continued)

River	Reach	River Sta	Profile	Plan	Q Total (cfs)	Min Ch El (ft)	W.S. Elev (ft)	Crit W.S. (ft)	E.G. Elev (ft)	E.G. Slope (ft/ft)	Vel Chnl (ft/s)	Flow Area (sq ft)	Top Width (ft)	Froude # Chl
Coal Creek	Coal Creek	5150.487	100-yr_565cfs	HECexist1	565.00	60.05	74.48	62.12	74.48	0.000003	0.19	2953.11	330.45	0.01
Coal Creek	Coal Creek	5126.07*	100-yr_565cfs	HECdesign1	565.00	59.53	74.48	62.72	74.48	0.000005	0.23	3076.91	360.69	0.01
Coal Creek	Coal Creek	5126.07*	100-yr_565cfs	HECexist1	565.00	59.53	74.48	62.72	74.48	0.000005	0.23	3076.91	360.69	0.01
Coal Creek	Coal Creek	5101.66*	100-yr_565cfs	HECdesign1	565.00	55.30	74.48	59.06	74.48	0.000004	0.23	3946.72	434.66	0.01
Coal Creek	Coal Creek	5101.66*	100-yr_565cfs	HECexist1	565.00	55.30	74.48	59.06	74.48	0.000004	0.23	3946.72	434.66	0.01
Coal Creek	Coal Creek	5077.248	100-yr_565cfs	HECdesign1	565.00	55.78	74.48	59.12	74.48	0.000003	0.22	4283.67	450.11	0.01
Coal Creek	Coal Creek	5077.248	100-yr_565cfs	HECexist1	565.00	55.78	74.48	59.12	74.48	0.000003	0.22	4283.67	450.11	0.01
Coal Creek	Coal Creek	5067.673	100-yr_565cfs	HECdesign1	565.00	55.84	74.48		74.48	0.000002	0.22	4050.32	373.21	0.01
Coal Creek	Coal Creek	5067.673	100-yr_565cfs	HECexist1	565.00	55.84	74.48		74.48	0.000002	0.22	4050.32	373.21	0.01
Coal Creek	Coal Creek	5044.837	100-yr_565cfs	HECdesign1	565.00	54.84	74.48		74.48	0.000002	0.23	4426.54	379.44	0.01
Coal Creek	Coal Creek	5044.837	100-yr_565cfs	HECexist1	565.00	54.84	74.48		74.48	0.000002	0.23	4426.54	379.44	0.01
Coal Creek	Coal Creek	5022.706	100-yr_565cfs	HECdesign1	565.00	53.84	74.48		74.48	0.000002	0.22	4809.26	386.01	0.01
Coal Creek	Coal Creek	5022.706	100-yr_565cfs	HECexist1	565.00	53.84	74.48		74.48	0.000002	0.22	4809.26	386.01	0.01
Coal Creek	Coal Creek	5002.2	100-yr_565cfs	HECdesign1	565.00	53.73	74.48		74.48	0.000002	0.21	4009.14	304.27	0.01
Coal Creek	Coal Creek	5002.2	100-yr_565cfs	HECexist1	565.00	53.73	74.48		74.48	0.000002	0.21	4009.14	304.27	0.01
Coal Creek	Coal Creek	4975.96	100-yr_565cfs	HECdesign1	565.00	52.73	74.48		74.48	0.000002	0.20	4315.34	308.16	0.01
Coal Creek	Coal Creek	4975.96	100-yr_565cfs	HECexist1	565.00	52.73	74.48		74.48	0.000002	0.20	4315.34	308.16	0.01
Coal Creek	Coal Creek	4954.856	100-yr_565cfs	HECdesign1	565.00	51.73	74.48		74.48	0.000001	0.25	4625.37	312.05	0.01
Coal Creek	Coal Creek	4954.856	100-yr_565cfs	HECexist1	565.00	51.73	74.48		74.48	0.000001	0.25	4625.37	312.05	0.01
Coal Creek	Coal Creek	4933.66	100-yr_565cfs	HECdesign1	565.00	50.73	74.48		74.48	0.000001	0.24	4939.38	315.94	0.01
Coal Creek	Coal Creek	4933.66	100-yr_565cfs	HECexist1	565.00	50.73	74.48		74.48	0.000001	0.24	4939.38	315.94	0.01
Coal Creek	Coal Creek	4914.324	100-yr_565cfs	HECdesign1	565.00	50.73	74.48		74.48	0.000000	0.18	4939.42	315.94	0.01
Coal Creek	Coal Creek	4914.324	100-yr_565cfs	HECexist1	565.00	50.73	74.48		74.48	0.000000	0.18	4939.42	315.94	0.01
Coal Creek	Coal Creek	4908.637	100-yr_565cfs	HECdesign1	565.00	50.90	74.48		74.48	0.000001	0.27	3488.97	257.88	0.01
Coal Creek	Coal Creek	4908.637	100-yr_565cfs	HECexist1	565.00	50.90	74.48		74.48	0.000001	0.27	3488.97	257.88	0.01
Coal Creek	Coal Creek	4903.362	100-yr_565cfs	HECdesign1	565.00	47.00	74.48		74.48	0.000001	0.27	3532.81	257.88	0.01
Coal Creek	Coal Creek	4903.362	100-yr_565cfs	HECexist1	565.00	47.00	74.48		74.48	0.000001	0.27	3532.81	257.88	0.01
Coal Creek	Coal Creek	4897.104	100-yr_565cfs	HECdesign1	565.00	47.00	74.48	52.10	74.48	0.000012	0.58	1642.02	257.87	0.03
Coal Creek	Coal Creek	4897.104	100-yr_565cfs	HECexist1	565.00	47.00	74.48	52.10	74.48	0.000012	0.58	1642.02	257.87	0.03
Coal Creek	Coal Creek	4892			Inl Struct									
Coal Creek	Coal Creek	4887.114	100-yr_565cfs	HECdesign1	565.00	47.20	74.43		74.46	0.000131	1.38	408.42	15.00	0.05
Coal Creek	Coal Creek	4887.114	100-yr_565cfs	HECexist1	565.00	47.20	74.43		74.46	0.000131	1.38	408.42	15.00	0.05
Coal Creek	Coal Creek	4885	100-yr_565cfs	HECdesign1	565.00	47.20	74.43		74.46	0.000131	1.38	408.41	15.00	0.05
Coal Creek	Coal Creek	4885	100-yr_565cfs	HECexist1	565.00	47.20	74.43		74.46	0.000131	1.38	408.41	15.00	0.05
Coal Creek	Coal Creek	4883	100-yr_565cfs	HECdesign1	565.00	47.20	74.43		74.46	0.000131	1.38	408.41	15.00	0.05
Coal Creek	Coal Creek	4883	100-yr_565cfs	HECexist1	565.00	47.20	74.43		74.46	0.000131	1.38	408.41	15.00	0.05
Coal Creek	Coal Creek	4881	100-yr_565cfs	HECdesign1	565.00	47.20	74.43		74.46	0.000131	1.38	408.40	15.00	0.05
Coal Creek	Coal Creek	4881	100-yr_565cfs	HECexist1	565.00	47.20	74.43		74.46	0.000131	1.38	408.40	15.00	0.05
Coal Creek	Coal Creek	4864.693	100-yr_565cfs	HECdesign1	565.00	47.20	74.41	51.28	74.45	0.000027	1.73	326.50	15.00	0.06
Coal Creek	Coal Creek	4864.693	100-yr_565cfs	HECexist1	565.00	47.20	74.41	51.28	74.45	0.000027	1.73	326.50	15.00	0.06
Coal Creek	Coal Creek	4650	I-405											
					Culvert									
Coal Creek	Coal Creek	4393.951	100-yr_565cfs	HECdesign1	565.00	45.16	50.75	49.10	51.45	0.006583	6.89	92.49	68.33	0.53
Coal Creek	Coal Creek	4393.951	100-yr_565cfs	HECexist1	565.00	45.16	50.75	49.10	51.45	0.006583	6.89	92.49	68.33	0.53

ATTACHMENT F



DESIGN DRAWING INDEX

Drawing No.	Drawing Title	DMP Attachment M Page Number
L86-GZK061	GENERAL ARRANGEMENT – TYPICAL TUNNEL SECTIONS – SEM TUNNEL	M-1
L86-GZK070	GENERAL ARRANGEMENT – AERIAL GUIDEWAY SECTIONS – LONG SPAN OVER I-405	M-2
L86-GZK071	GENERAL ARRANGEMENT – AERIAL GUIDEWAY SECTIONS – DUAL TRACK, DUAL TUBS	M-3
L86-CXP105	CIVIL – DEMOLITION AND REMOVAL PLAN – R27 STA 27+50 TO R27 STA 32+00	M-4
L86-CXP106	CIVIL – DEMOLITION AND REMOVAL PLAN – R27 STA 32+00 TO R27 STA 36+90	M-5
L86-CXP107	CIVIL – DEMOLITION AND REMOVAL PLAN – R27 STA 36+90 TO R32 STA 101+00	M-6
L86-CXP110	CIVIL – DEMOLITION AND REMOVAL PLAN – EB STA 574+50 TO EB STA 580+00	M-7
L86-CXP111	CIVIL – DEMOLITION AND REMOVAL PLAN – EB STA 580+00 TO EB STA 585+50	M-8
L86-CMP100	CIVIL – PAVEMENT MARKING AND SIGNAGE	M-9
L86-CMP107	CIVIL – PAVEMENT MARKING AND SIGNAGE	M-10
L86-CMP109	CIVIL – PAVEMENT MARKING AND SIGNAGE	M-11
L86-CMP113	CIVIL – PAVEMENT MARKING AND SIGNAGE	M-12
L86-CGP114	CIVIL – GRADING AND PAVING PLAN – EB STA 595+50 TO EB STA 601+00	M-13
L86-CGP145	CIVIL – GRADING AND PAVING PLAN	M-14
L86-CCP001	CIVIL – CONSTRUCTION STAGING AREAS – SOUTH PORTAL	M-15
L86-CCP002	CIVIL – CONSTRUCTION STAGING AREAS – MID-TUNNEL	M-16
L86-CCP003	CIVIL – CONSTRUCTION STAGING AREAS – NORTH PORTAL/BTC STATION	M-17
L86-CCP004	CIVIL – CONSTRUCTION STAGING AREAS – WEST OF 116 TH AVE NE	M-18
L86-CCP005	CIVIL – CONSTRUCTION STAGING AREAS – EAST OF 116 TH AVE NE	M-19
L86-UCP100	COMPOSITE UTILITY PLAN – EB STA 521+00 TO EB STA 536+00	M-20
L86-UCP101	COMPOSITE UTILITY PLAN – EB STA 536+00 TO EB STA 540+00	M-21
L86-UCP102	COMPOSITE UTILITY PLAN – EB STA 540+00 TO EB STA 543+00	M-22
L86-UCP103	COMPOSITE UTILITY PLAN – EB STA 543+00 TO EB STA 546+00	M-23
L86-UCP104	COMPOSITE UTILITY PLAN – EB STA 546+00 TO EB STA 551+50	M-24
L86-UCP105	COMPOSITE UTILITY PLAN – EB STA 551+50 TO EB STA 557+00	M-25
L86-UCP106	COMPOSITE UTILITY PLAN – EB STA 557+00 TO EB STA 562+00	M-26

L86-UCP107	COMPOSITE UTILITY PLAN – EB STA 562+00 TO EB STA 564+00	M-27
L86-UCP108	COMPOSITE UTILITY PLAN – EB STA 564+00 TO EB STA 570+00	M-28
L86-UCP109	COMPOSITE UTILITY PLAN – EB STA 570+00 TO EB STA 575+00	M-29
L86-UCP110	COMPOSITE UTILITY PLAN – EB STA 575+00 TO EB STA 580+00	M-30
L86-UCP111	COMPOSITE UTILITY PLAN – EB STA 580+00 TO EB STA 585+00	M-31
L86-UCP112	COMPOSITE UTILITY PLAN – EB STA 585+00 TO EB STA 590+00	M-32
L86-UCP113	COMPOSITE UTILITY PLAN – EB STA 590+00 TO EB STA 595+00	M-33
L86-UCP114	COMPOSITE UTILITY PLAN – EB STA 595+00 TO EB STA 600+00	M-34
L86-UCP115	COMPOSITE UTILITY PLAN – EB STA 600+00 TO EB STA 605+00	M-35
L86-TMP100	TRAFFIC STAGING PLAN CONCEPT KEY MAP – SOUTH PORTAL TO NE 6 TH ST	M-36
L86-TMP101	TRAFFIC STAGING PLAN CONCEPT KEY MAP – NE 6 TH ST TO 116 TH AVE NE	M-37
L86-TMP209	TRAFFIC CONTROL PLAN – NE 6 TH ST RAMP ON-RAMP CLOSURE	M-38
L86-TMP210	TRAFFIC CONTROL PLAN – NE 6 TH ST RAMP OFF-RAMP CLOSURE	M-39
L86-TMP211	TRAFFIC CONTROL PLAN – NE 6 TH ST RAMP OFF-RAMP CLOSURE	M-40
L86-TNP101	TRAFFIC – OPERATIONAL SIGNAGE	M-41
L86-TNP102	TRAFFIC – OPERATIONAL SIGNAGE	M-42
L86-TNP103	TRAFFIC – OPERATIONAL SIGNAGE	M-43
L86-TNP104	TRAFFIC – OPERATIONAL SIGNAGE	M-44
L86-TNP105	TRAFFIC – OPERATIONAL SIGNAGE	M-45
L86-TNP106	TRAFFIC – OPERATIONAL SIGNAGE	M-46
L86-TNP107	TRAFFIC – OPERATIONAL SIGNAGE	M-47
L86-TNP108	TRAFFIC – OPERATIONAL SIGNAGE	M-48
L86-TNP109	TRAFFIC – OPERATIONAL SIGNAGE	M-49
L86-TNP110	TRAFFIC – OPERATIONAL SIGNAGE	M-50
L86-TSP100	TRAFFIC SIGNALIZATION – 112 TH AVE SE/HILTON DRIVEWAY	M-51
L86-TSP101	TRAFFIC SIGNALIZATION – INTERCONNECT – 112 TH AVE SE	M-52
L86-TSP102	TRAFFIC SIGNALIZATION – 112 TH AVE SE/MAIN ST	M-53
L86-TSP105	TRAFFIC SIGNALIZATION – 110 TH AVE NE/NE 2 ND PL	M-54
L86-TSP106	TRAFFIC SIGNALIZATION – 110 TH AE NE/NE 6 TH ST	M-55
L86-TSP107	TRAFFIC SIGNALIZATION – 110 TH AVE NE/NE 6 TH ST	M-56
L86-TSP109	TRAFFIC SIGNALIZATION – 112 TH AVE NE/NE 6 TH ST	M-57
L86-TSP110	TRAFFIC SIGNALIZATION – NE 6 TH ST/HOV RAMP	M-58

L86-LMP114	LANDSCAPE – SITE RESTORATION PLAN – CORRIDOR	M-59
L86-LMP115	LANDSCAPE – SITE RESTORATION PLAN – CORRIDOR	M-60
L86-LMP116	LANDSCAPE – SITE RESTORATION PLAN – CORRIDOR	M-61
L86-LMD101	LANDSCAPE – SITE RESTORATION DETAILS – CORRIDOR	M-62
L86-LMD102	LANDSCAPE – SITE RESTORATION DETAILS – CORRIDOR	M-63
L86-LMD103	LANDSCAPE – SITE RESTORATION DETAILS – CORRIDOR	M-64
L86-LPP100	LANDSCAPE – PLANTING PLAN – CORRIDOR	M-65
L86-LPP101	LANDSCAPE – PLANTING PLAN – CORRIDOR	M-66
L86-LPP102	LANDSCAPE – PLANTING PLAN – CORRIDOR	M-67
L86-LPP103	LANDSCAPE – PLANTING PLAN – CORRIDOR	M-68
L86-LPP105	LANDSCAPE – PLANTING PLAN – CORRIDOR	M-69
L86-LPP106	LANDSCAPE – PLANTING PLAN – CORRIDOR	M-70
L86-LPP107	LANDSCAPE – PLANTING PLAN – CORRIDOR	M-71
L86-LPP108	LANDSCAPE – PLANTING PLAN – CORRIDOR	M-72
L86-LPP109	LANDSCAPE – PLANTING PLAN – CORRIDOR	M-73
L86-LPP110	LANDSCAPE – PLANTING PLAN – CORRIDOR	M-74
L86-LPP111	LANDSCAPE – PLANTING PLAN – CORRIDOR	M-75
L86-LPP112	LANDSCAPE – PLANTING PLAN – CORRIDOR	M-76
L86-LPP113	LANDSCAPE – PLANTING PLAN – CORRIDOR	M-77
L86-LPP114	LANDSCAPE – PLANTING PLAN – CORRIDOR	M-78
L86-LPP141	LANDSCAPE – PLANTING PLAN – CORRIDOR	M-79
L86-LPP143	LANDSCAPE – PLANTING PLAN – CORRIDOR	M-80
L86-LPP144	LANDSCAPE – PLANTING PLAN – CORRIDOR	M-81
L86-LPP145	LANDSCAPE – PLANTING PLAN – CORRIDOR	M-82
E11-AAP001	EAST MAIN STATION – ARCHITECTURAL – MUNICIPAL CODE INFORMATION	M-83
E11-APP101	EAST MAIN STATION – ARCHITECTURAL FLOOR PLAN - NORTH	M-84
E11-APP102	EAST MAIN STATION – ARCHITECTURAL FLOOR PLAN - CENTRAL	M-85
E11-APP103	EAST MAIN STATION – ARCHITECTURAL FLOOR PLAN - NORTH	M-86
E11-AEX201	EAST MAIN STATION – ARCHITECTURAL LONGITUDINAL SECTION 2 – SOUTH – LOOKING EAST	M-87
E11-AEX203	EAST MAIN STATION – ARCHITECTURAL LONGITUDINAL SECTION 2 – NORTH – LOOKING EAST	M-88
E11-LSP100	LANDSCAPE – HARDCAPE PLAN – WEST – EAST MAIN STATION	M-89
E11-LSP101	LANDSCAPE – HARDCAPE PLAN – EAST – EAST MAIN STATION	M-90

E15-APP103	BTC STATION – FLOOR PLAN – LOWER STREET LEVEL EAST SECTOR	M-91
E15-APP201	BTC STATION – FLOOR PLAN – PLATFORM LEVEL WEST SECTOR	M-92
E15-APP202	BTC STATION – FLOOR PLAN – PLATFORM LEVEL CENTRAL SECTOR	M-93
E15-APP203	BTC STATION – FLOOR PLAN – PLATFORM LEVEL EAST SECTOR	M-94
E15-APP401	BTC STATION – FLOOR PLAN – SURFACE LEVEL WEST SECTOR	M-95
E15-AEE011	BTC STATION – EXTERIOR ELEVATIONS – NORTH-EAST	M-96
E15-AEE012	BTC STATION – EXTERIOR ELEVATIONS – NORTH-CENTRAL	M-97
E15-AEE013	BTC STATION – EXTERIOR ELEVATIONS – NORTH-WEST	M-98
E15-LSP101	BTC STATION – LANDSCAPE HARDSCAPE PLAN – WEST SEGMENT 1	M-99
E15-LSP104	BTC STATION – LANDSCAPE – HARDSCAPE PLAN – EAST SEGMENT	M-100
E19-APP103	HOSPITAL STATION – PLAN – STATION PLAZA LEVEL PLAN CENTRAL	M-101
E19-APP202	HOSPITAL STATION – PLAN – STATION PLATFORM PLAN SOUTH	M-102
E19-APP203	HOSPITAL STATION – PLAN – STATION PLATFORM PLAN SOUTH	M-103
E19-APP204	HOSPITAL STATION – PLAN – STATION PLATFORM PLAN SOUTH	M-104
E19-AEE105	HOSPITAL STATION – ELEV – STATION EAST ELEVATION SOUTH	M-105
E19-AEE106	HOSPITAL STATION – ELEV – STATION EAST ELEVATION CENTRAL	M-106
E19-AEE107	HOSPITAL STATION – ELEV – STATION EAST ELEVATION NORTH	M-107
L85-LPP104	LANDSCAPE – PLANTING PLAN – I-90 RAMP	M-108
L85-LPP105	LANDSCAPE – PLANTING PLAN – I-90 RAMP	M-109
L85-LPP106	LANDSCAPE – PLANTING PLAN – BELLEVUE WAY	M-110
L85-LPP107	LANDSCAPE – PLANTING PLAN – BELLEVUE WAY	M-111
L85-LPP108	LANDSCAPE – PLANTING PLAN – BELLEVUE WAY AND PARK MITIGATION	M-112
L85-LPP109	LANDSCAPE – PLANTING PLAN – BELLEVUE WAY AND PARK MITIGATION	M-113
L85-LPP110	LANDSCAPE – PLANTING PLAN – BELLEVUE WAY	M-114
L85-LPP111	LANDSCAPE – PLANTING PLAN – BELLEVUE WAY AND PARK MITIGATION	M-115
L85-LPP112	LANDSCAPE – PLANTING PLAN – BELLEVUE WAY AND PARK MITIGATION	M-116
L85-LPP113	LANDSCAPE – PLANTING PLAN – BELLEVUE WAY AND PARK MITIGATION	M-117
L85-LPP114	LANDSCAPE – PLANTING PLAN – BELLEVUE WAY AND PARK MITIGATION	M-118
L85-LPX100	LANDSCAPE – PLANTING SECTIONS – WINTERS HOUSE	M-119

XREF LIST:
 *E330-T86-SX200
 *E335-T86-EPT001
 *GB-SEAL-JCS40860
 *E330-T86-JY200
 *E335-GB-T82234
 *E330-T86-MSX200

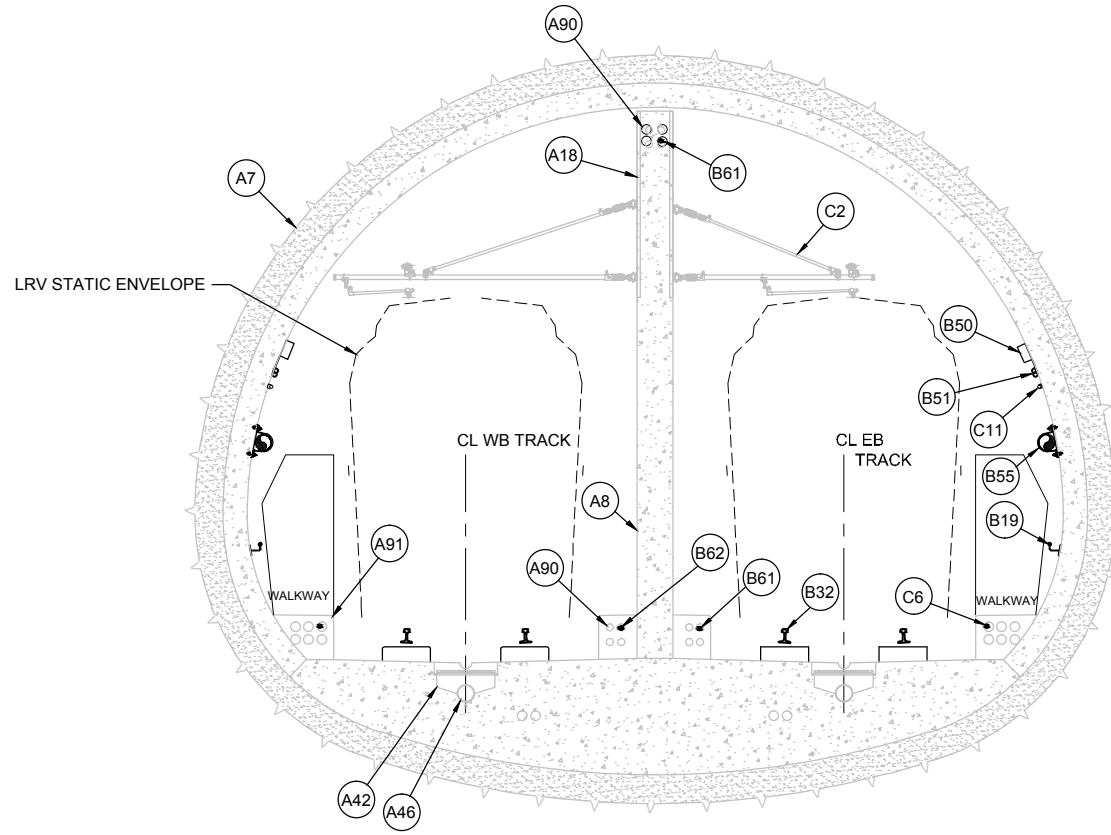

SEM TUNNEL SECTION, TYPICAL

NTS

NOTE:

1. NOTES ON ONE TRACKWAY APPLY TO THE OTHER.

CONTRACT E330 (NIC)

- (A7) SEM TUNNEL AND ALL ASSOCIATED PERMANENT AND TEMPORARY WORKS.
- (A8) CENTER WALL
- (A18) UNISTRUT FOR OCS SUPPORTS
- (A42) DRAINAGE SYSTEM INCLUDING INLETS
- (A46) DRAINAGE PIPE TO CONTAINED SYSTEM AND/OR SANITARY SEWER
- (A90) CONDUIT EMBEDDED IN CONCRETE
- (A91) DUCTBANK EMBEDDED IN CONCRETE WITH WALKWAY ON TOP

CONTRACT E335

- (B19) HANDRAIL
- (B32) DIRECT FIXATION TRACK WITH CONTINUOUSLY WELDED RAIL, DF FASTENERS, INSERTS AND ALL RELATED APPURTENANCES ON RAISED PLINTH
- (B50) LIGHTING
- (B51) LOCAL ELECTRICAL POWER FOR LIGHTING
- (B55) FIRE PROTECTION STANDPIPE
- (B61) 480 V POWER LINE TO VENTILATION FANS (WHERE APPLICABLE)
- (B62) MEDIUM VOLTAGE (12.47 KV) TIE LINE

CONTRACT E750 (NIC)

- (C2) OCS CONTACT AND MESSENGER CABLES FITTINGS AND HARDWARE CANTILEVERS
- (C6) CABLING FOR SIGNALS AND COMMUNICATIONS
- (C11) RADIATING CABLE

ORIGINATED BY: / DATE: /
 CHECKED BY: / DATE: /
 CORRECTED BY: / DATE: /
 VERIFIED BY: / DATE: /
 12/17/13 1:43:22 PM | RYANU
 V:\SHAREPOINT\SOUNDTRANSIT.ORG\SS\LISTES\CAD\LIB\REF\E335\DRAWINGS\E335-L86-CZK061.DWG

60% SUBMITTAL

DESIGNED BY:
J. RYAN
 DRAWN BY:
R. PUNSALAN
 CHECKED BY:
J. SCHLICK
 APPROVED BY:
J. SCHUTT



LINE IS 1" AT FULL SCALE



SCALE:
NTS
 FILENAME:
E335-L86-GZK061
 CONTRACT No.:
RTA/LR XXXX-XX
 DATE:
12/20/2013

**EAST LINK EXTENSION
 CONTRACT E335**
 DOWNTOWN BELLEVUE TO SPRING DISTRICT
 GENERAL ARRANGEMENT
 TYPICAL TUNNEL SECTIONS
 SEM TUNNEL

DRAWING No.:
L86-GZK061
 LOCATION ID:
G86
 SHEET No.: REV:
0

No.	DATE	DSN	CHK	APP	REVISION

XREF LIST:
 GB-SEAL-JCS40860
 XE335-GB-T823-34
 XE335-L86-KYX300
 XE335-L86-SYX001
 XE335-L86-JYX300

NOTE:
 1. NOTES ON ONE TRACKWAY APPLY TO THE OTHER.

CONTRACT E330 (NIC)

NO ITEMS

CONTRACT E335

- (B1) PRECAST SEGMENTAL LONG SPAN TUB GIRDER, GUIDEWAY SUBSTRUCTURE, COLUMNS, BENTS, SEISMIC BUFFERS, RESTRAINERS, EXPANSION JOINTS AND ALL ASSOCIATED PERMANENT AND TEMPORARY WORKS.
- (B19) HANDRAIL AND/OR SOUND WALL
- (B33) DIRECT FIXATION CONTINUOUSLY WELDED RAIL WITH GUARD RAILS, DF FASTENERS, INSERTS AND ALL RELATED APPURTENANCES ON RAISED PLINTH
- (B55) FIRE PROTECTION STANDPIPE AND PIPE HANGERS
- (B81) OCS POLE ANCHOR BOLT ASSEMBLY (ALL COMPONENTS EXCLUDING OCS POLES AND TAPERED WASHERS)
- (B95) DUCTBANK TRAY WITH WALKWAY ON TOP

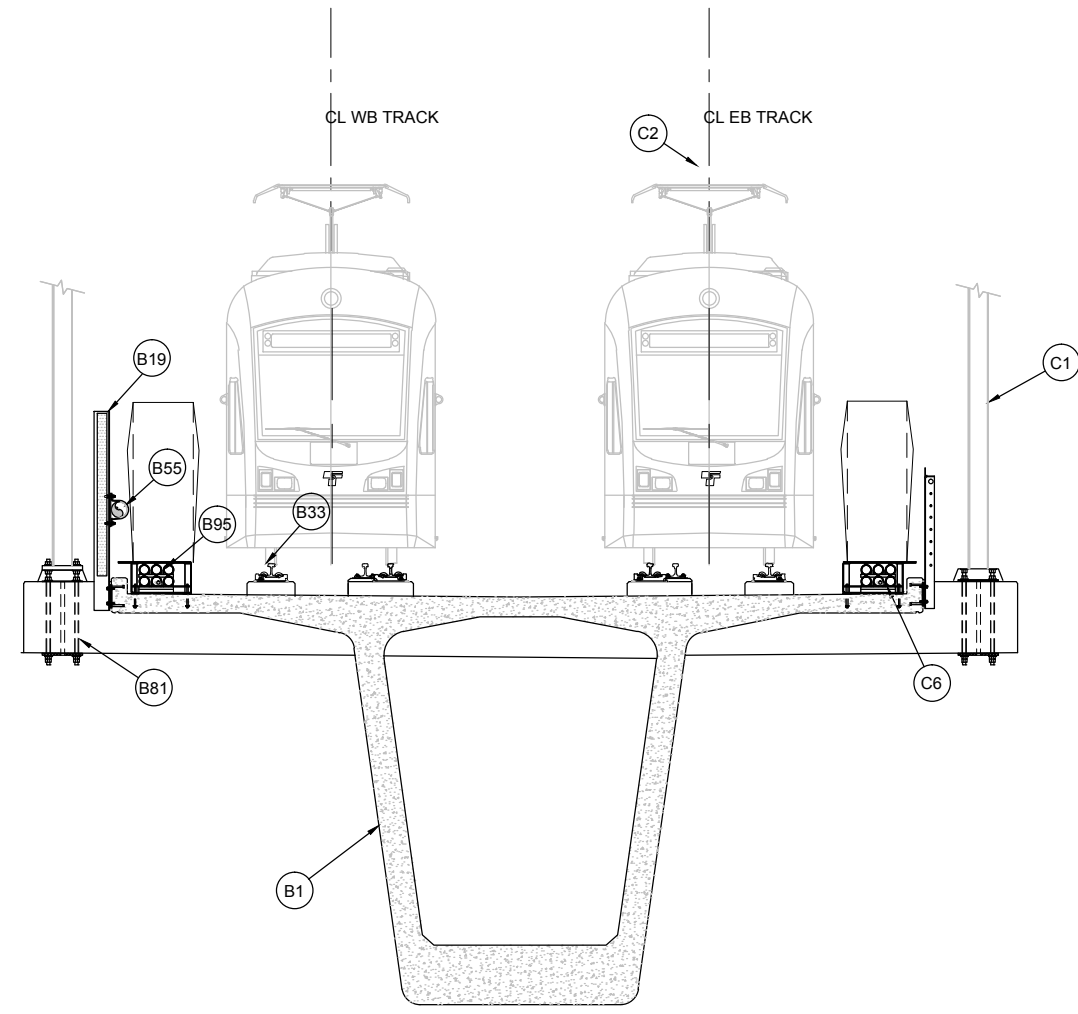





CONTRACT E750 (NIC)

- (C1) OCS POLES, TAPERED WASHERS AND GROUT
- (C2) CONTACT AND MESSENGER CABLES FITTINGS AND HARDWARE CANTILEVERS, CROSS SPANS AND LIGHTENING ARRESTORS GROUNDING CONNECTIONS
- (C6) CABLING FOR SIGNALS AND COMMUNICATIONS

AERIAL GUIDEWAY - LONG SPAN, TYPICAL

NTS

ORIGINATED BY: / DATE: / CORRECTED BY: / DATE: /
 CHECKED BY: / DATE: / VERIFIED BY: / DATE: /
 11/28/13 | 3:03 PM | CALDWELL
 C:\USERS\PUBLIC\DOCUMENTS\CALDWELL\JH\TTPS\SHAREPOINT\ SOUNDTRANSIT\ORG\443\SITES\CAD\ELBEL\RED\E335\DRAWINGS\E335-L86-GZK070.DWG

60% SUBMITTAL					DESIGNED BY: J. RYAN DRAWN BY: R. PUNSALAN CHECKED BY: J. SCHLICK APPROVED BY: J. SCHUTT		  FINAL DESIGN PARTNERS.		SCALE: NTS FILENAME: E335-L86-GZK070 CONTRACT No.: RTA/LR XXXX-XX DATE: 12/20/2013	EAST LINK EXTENSION CONTRACT E335 DOWNTOWN BELLEVUE TO SPRING DISTRICT GENERAL ARRANGEMENT AERIAL GUIDEWAY SECTIONS LONG SPAN OVER I-405	DRAWING No.: L86-GZK070 LOCATION ID: G86 SHEET No.: REV: 0
No.	DATE	DSN	CHK	APP	REVISION						

XREF LIST:
 GB-SEAL-JCS49860
 XE335-GB-T8223-34
 XE335-L86-SYX001
 XE335-L86-KYX300
 XE335-L86-JYX300

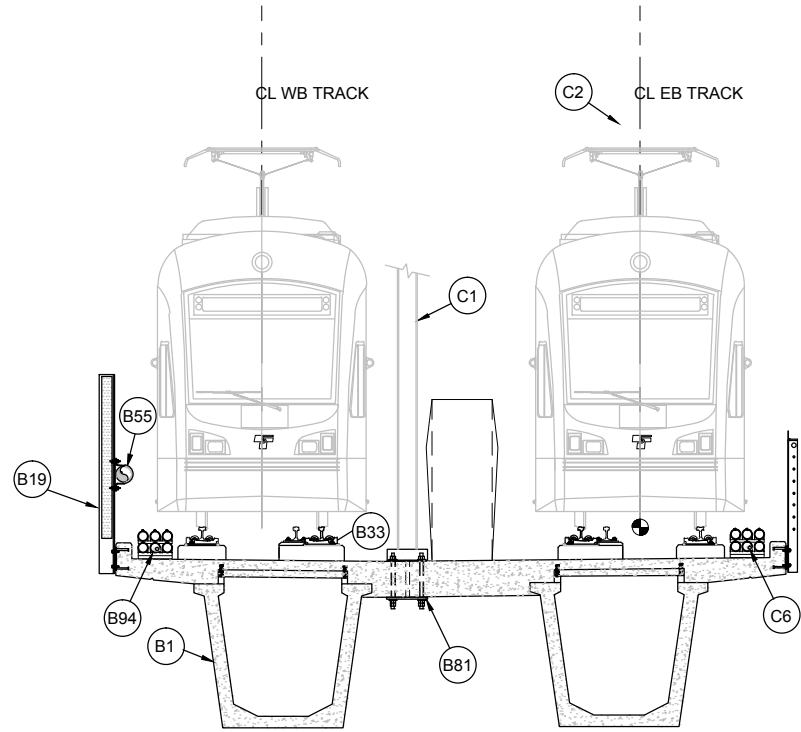

AERIAL GUIDEWAY
 NTS

NOTE:
 1. NOTES ON ONE TRACKWAY APPLY TO THE OTHER.

CONTRACT E330 (NIC)

NO ITEMS

CONTRACT E335

- (B1) PRECAST SEGMENTAL DUAL TUB GIRDER, GUIDEWAY SUBSTRUCTURE, COLUMNS, BENTS, SEISMIC BUFFERS, RESTRAINERS, EXPANSION JOINTS AND ALL ASSOCIATED PERMANENT AND TEMPORARY WORKS.
- (B19) HANDRAIL AND/OR SOUND WALL
- (B33) DIRECT FIXATION CONTINUOUSLY WELDED RAIL WITH GUARD RAILS, DF FASTENERS, INSERTS AND ALL RELATED APPURTENANCES ON RAISED PLINTH
- (B55) FIRE PROTECTION STANDPIPE AND PIPE HANGERS
- (B81) OCS POLE ANCHOR BOLT ASSEMBLY. (ALL COMPONENTS EXCLUDING OCS POLES AND TAPERED WASHERS)
- (B94) DUCTBANK TRAY

CONTRACT E750 (NIC)

- (C1) OCS POLES, TAPERED WASHERS AND GROUT
- (C2) CONTACT AND MESSENGER CABLES FITTINGS AND HARDWARE CANTILEVERS, CROSS SPANS, ARRESTORS AND GROUNDING CONNECTIONS
- (C6) CABLING FOR SIGNALS AND COMMUNICATIONS

ORIGINATED BY: / DATE: /
 CHECKED BY: / DATE: /
 CORRECTED BY: / DATE: /
 BACK-CHECKED BY: / DATE: /
 VERIFIED BY: / DATE: /
 11/28/13 3:03 PM | CALDWELL
 C:\USERS\PUBLIC\DOCUMENTS\CALDWELL\JH\TTPS\SHAREPOINT\ SOUNDTRANSIT\ORG\443\SITES\CAD\ELBEL\RED\E335\DRAWINGS\E335-L86-GZK071.DWG

60% SUBMITTAL					
No.	DATE	DSN	CHK	APP	REVISION

DESIGNED BY:
J. RYAN
 DRAWN BY:
R. PUNSALAN
 CHECKED BY:
J. SCHLICK
 APPROVED BY:
J. SCHUTT

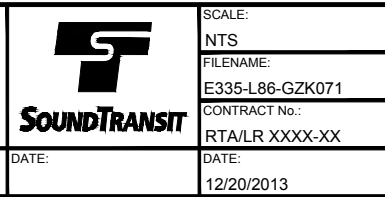
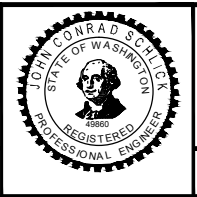

SCALE:
 NTS
 FILENAME:
E335-L86-GZK071
 CONTRACT No.:
RTA/LR XXXX-XX
 DATE:
12/20/2013

DRAWING No.:
L86-GZK071
 LOCATION ID:
G86
 SHEET No.:
 REV:
0

**EAST LINK EXTENSION
 CONTRACT E335**
 DOWNTOWN BELLEVUE TO SPRING DISTRICT
 GENERAL ARRANGEMENT
 AERIAL GUIDEWAY SECTIONS
 DUAL TRACK, DUAL TUBS

XREF LIST:
 XE330-E19-SFP400
 XE335-E19-APP100
 XE335-E19-SFP100
 XE335-E19-SGP100
 XE335-L86-CAP100
 XE335-L86-CAP100
 XEL-0228r
 XEL-0228f
 XEL-0228b
 XEL-0528r
 XEL-0528f
 XEL-0528b
 XE335-09-TB22x34
 XEL-0228vg
 XEL-0528vg
 XE335-L86-RFP100
 XE335-L86-CXP100
 GB-SEAL-MJM31003
 XE335-L86-CCP100
 E335-L86-CAP_C30
 XE330-T86-CCP100
 XE335-L86-LTP100

ORIGINATED BY: / DATE: /
 CORRECTED BY: / DATE: /
 BACK-CHECKED BY: / DATE: /
 RUBUSHKA V
 11/21/13 10:51 AM
 C:\USERS\PUBLIC\DOCUMENTS\13RUBUSHKA\13RUBUSHKA\HITPS\SHAREPOINT\SOUNDTRANSIT.ORG\443\SITES\CAD\ELBEL\REDESIGN\DRAWINGS\E335-L86-CXP105.DWG

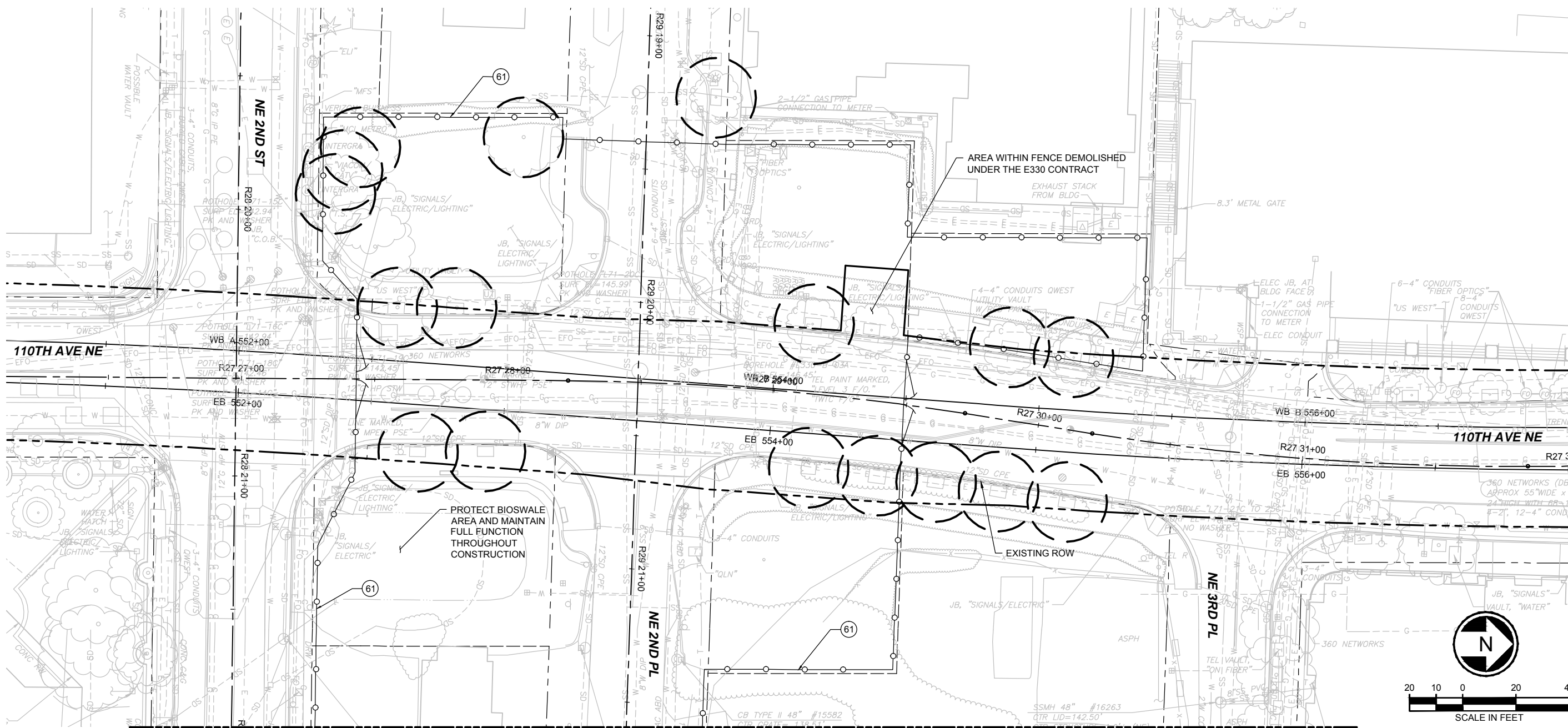

NOTES:

1. SEE COMPOSITE UTILITY DRAWINGS AND DRAINAGE DRAWINGS FOR UTILITIES TO BE REMOVED AND THOSE TO REMAIN.
2. SEE ILLUMINATION DRAWINGS FOR LUMINAIRES TO BE REMOVED AND THOSE TO REMAIN.
3. SEE DRAWINGS L86-CCP001 THRU L86-CCP005 FOR HORIZONTAL CONTROL OF CONSTRUCTION FENCING AND CONTRACTOR STAGING AND LAYDOWN AREAS.
4. REMOVE ALL EXISTING SURFACE IMPROVEMENTS WITHIN THE WORK AREA UNLESS OTHERWISE NOTED. THE DEMOLITION AND REMOVAL PLAN PROVIDES OVERALL DEMOLITION SCOPE BUT MAY NOT SHOW ALL SURFACE IMPROVEMENTS TO BE REMOVED WITHIN THE WORK AREA.
5. SEE DRAWINGS L86-TMP101 THRU L86-TMP209 FOR MAINTENANCE OF TRAFFIC PHASING CONCEPTS.

CONSTRUCTION NOTES:

- ① MAINTAIN TEMPORARY CONSTRUCTION FENCING INSTALLED IN E330 CONTRACT

SEE DWG L86-CXP142

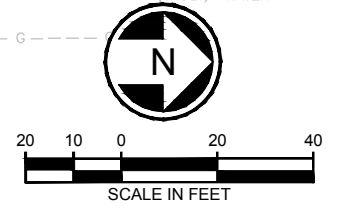

SEE DWG L86-CXP106

60% SUBMITTAL

DESIGNED BY:	J. MATTHEWS
DRAWN BY:	V. RUBUSHKA
CHECKED BY:	C. OXFORD
APPROVED BY:	M. MORAVEC

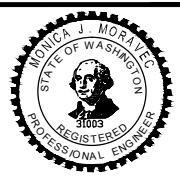

LINE IS 1" AT FULL SCALE



SCALE:	1" = 20'
FILENAME:	E335-L86-CXP105
CONTRACT No.:	RTA/LR XXXX-XX
DATE:	12/20/2013

EAST LINK EXTENSION CONTRACT E335
 DOWNTOWN BELLEVUE TO SPRING DISTRICT
 CIVIL
 DEMOLITION AND REMOVAL PLAN
 R27 STA 27+50 TO R27 STA 32+00

DRAWING No.:	L86-CXP105
LOCATION ID:	
SHEET No.:	0
REV:	

XREF LIST:
 XE335-E19-APP100
 XE335-E19-SFP100
 XE335-E19-SGP100
 XE335-L86-CAP100
 XE335-L86-KAP100
 XEL-0228rx
 XEL-0228lf
 XEL-0228ul
 XEL-0528rx
 XEL-0528lf
 XEL-0528ul
 XE335-OB-TB22x34
 XEL-0228vg
 XEL-0528vg
 XE335-L86-RPP100
 GB-SEAL-MMJ1003
 XE335-L86-CCP100
 XE335-L86-CXP100
 XE335-L86-LTP100

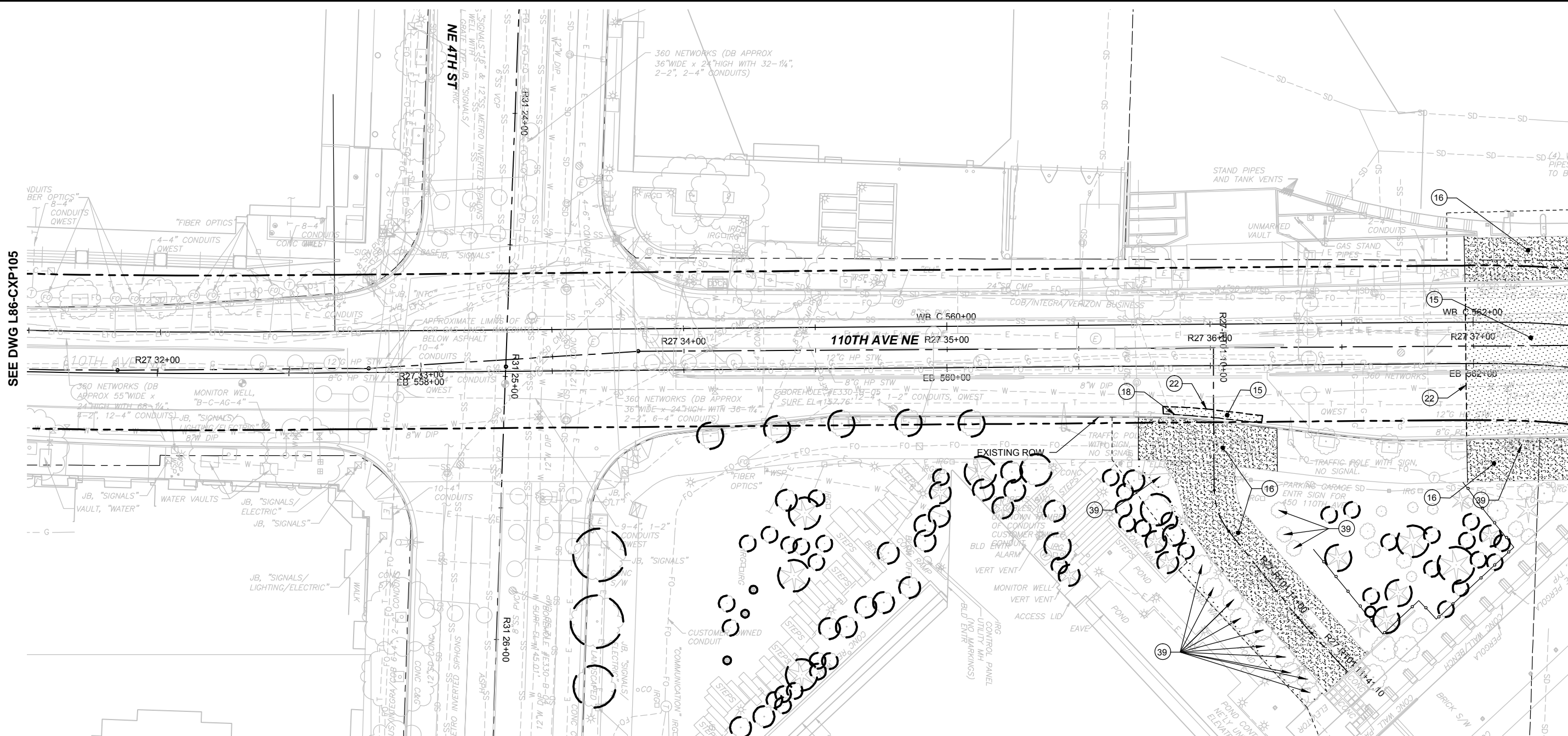

SEE DWG L86-CXP105

SEE DWG L86-CXP107

NOTES:

1. SEE COMPOSITE UTILITY DRAWINGS AND DRAINAGE DRAWINGS FOR UTILITIES TO BE REMOVED AND THOSE TO REMAIN.
2. SEE ILLUMINATION DRAWINGS FOR LUMINAIRES TO BE REMOVED AND THOSE TO REMAIN.
3. SEE DRAWINGS L86-CCP001 THRU L86-CCP005 FOR HORIZONTAL CONTROL OF CONSTRUCTION FENCING AND CONTRACTOR STAGING AND LAYDOWN AREAS.
4. REMOVE ALL EXISTING SURFACE IMPROVEMENTS WITHIN THE WORK AREA UNLESS OTHERWISE NOTED. THE DEMOLITION AND REMOVAL PLAN PROVIDES OVERALL DEMOLITION SCOPE BUT MAY NOT SHOW ALL SURFACE IMPROVEMENTS TO BE REMOVED WITHIN THE WORK AREA.
5. SEE DRAWINGS L86-TMP101 THRU L86-TMP209 FOR MAINTENANCE OF TRAFFIC PHASING CONCEPTS.

CONSTRUCTION NOTES:

- 15 REMOVE ASPHALT CONCRETE.
- 16 REMOVE CEMENT CONCRETE.
- 18 REMOVE CURB AND GUTTER.
- 22 SAWCUT EXISTING PAVEMENT
- 39 REMOVE TREE.

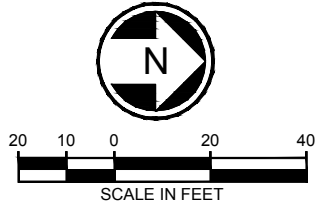

ORIGINATED BY: / DATE: /
 CHECKED BY: / DATE: /
 BACK-CHECKED BY: / DATE: /
 RUBUSHKA
 C:\USERS\PUBLIC\DOCUMENTS\RUBUSHKA\HITPSHAREPOINT.SOUNDTRANSIT.ORG\43SITES\CAD\BELREDE\E335DRAWINGS\E335-L86-CXP106.DWG

60% SUBMITTAL

DESIGNED BY:
 J. MATTHEWS
 DRAWN BY:
 V. RUBUSHKA
 CHECKED BY:
 C. OXFORD
 APPROVED BY:
 M. MORAVEC



SCALE:
 1" = 20'
 FILENAME:
 E335-L86-CXP106
 CONTRACT No.:
 RTA/LR XXXX-XX
 DATE:
 12/20/2013

**EAST LINK EXTENSION
 CONTRACT E335**
 DOWNTOWN BELLEVUE TO SPRING DISTRICT
 CIVIL
 DEMOLITION AND REMOVAL PLAN
 R27 STA 32+00 TO R27 STA 36+90

DRAWING No.:	L86-CXP106
LOCATION ID:	
SHEET No.:	REV: 0

XREF LIST:
 XE330-E15-SFP400
 XE335-E19-APP100
 XE335-E19-SFP100
 XE335-E19-SGP100
 XE335-L86-CAP100
 XE335-L86-KAP100
 XEL-0228rx
 XEL-0228sf
 XEL-0228ut
 XEL-0528rx
 XEL-0528sf
 XEL-0528ut
 XE335-031-TB22x34
 XEL-0528vg
 XEL-0228vg
 XE335-L86-RFP100
 CB-SEAL-MJM31003
 XE335-L86-CXP100
 XE335-L86-CCP100
 XE335-L86-LTP100

ORIGINATED BY: / DATE: /
 CHECKED BY: / DATE: /
 BACK-CHECKED BY: / DATE: /
 CORRECTED BY: / DATE: /
 VERIFIED BY: / DATE: /
 11/19/13 | 9:58 AM | RUBASHKAV
 C:\USERS\PUBLIC\DOCUMENTS\IRUBASHKAV\PROJECTS\HAREPOINT_SOUNDTRANSIT\ORIG\43\SITES\CAD\ELBEL\RED\E335-L86-CXP107.DWG

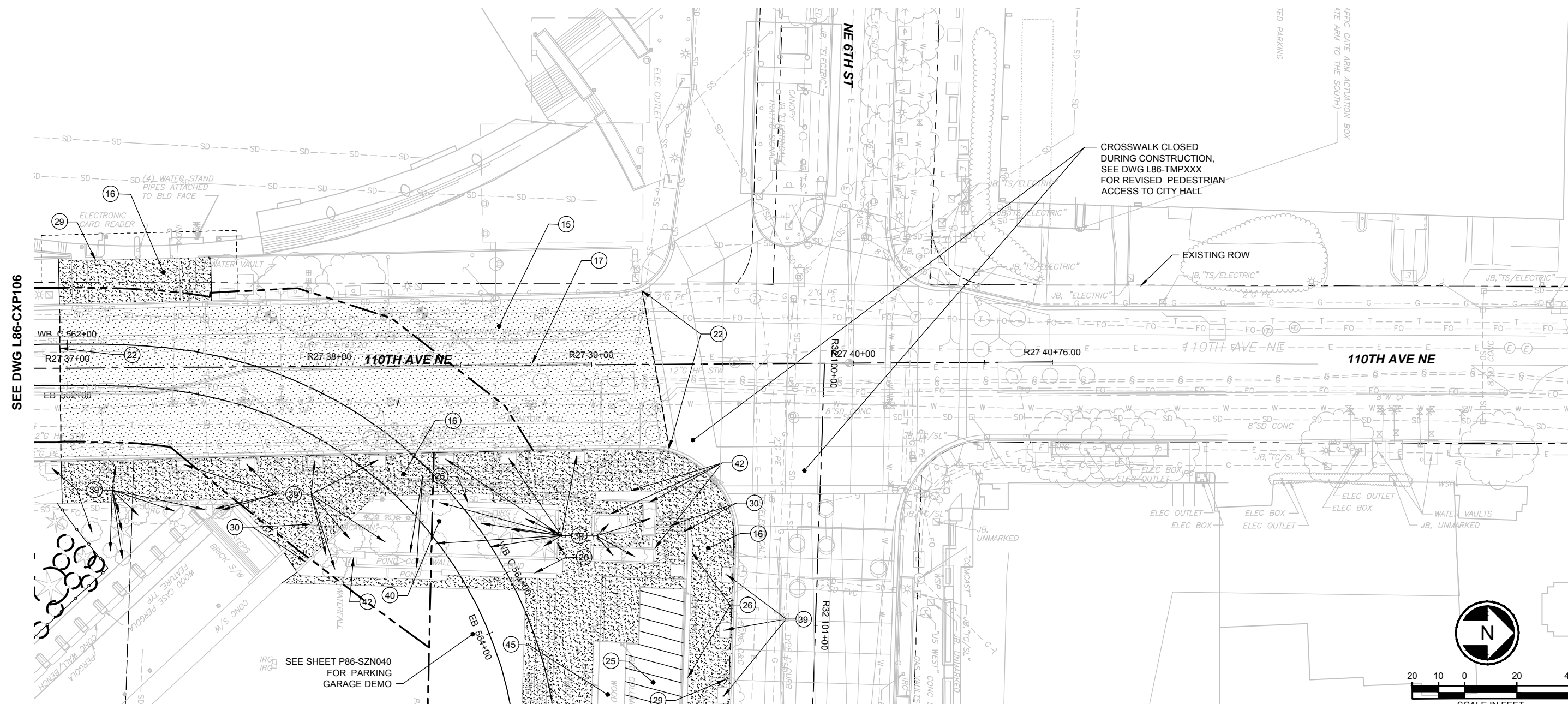

CROSSWALK CLOSED DURING CONSTRUCTION, SEE DWG L86-TMPXXX FOR REVISED PEDESTRIAN ACCESS TO CITY HALL

EXISTING ROW

SEE SHEET P86-SZN040 FOR PARKING GARAGE DEMO

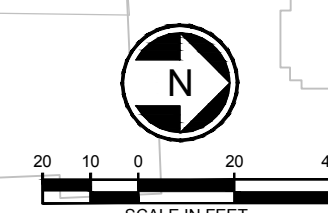

- NOTES:**
- SEE COMPOSITE UTILITY DRAWINGS AND DRAINAGE DRAWINGS FOR UTILITIES TO BE REMOVED AND THOSE TO REMAIN.
 - SEE ILLUMINATION DRAWINGS FOR LUMINAIRES TO BE REMOVED AND THOSE TO REMAIN.
 - SEE DRAWINGS L86-CCP001 THRU L86-CCP005 FOR HORIZONTAL CONTROL OF CONSTRUCTION FENCING AND CONTRACTOR STAGING AND LAYDOWN AREAS.
 - REMOVE ALL EXISTING SURFACE IMPROVEMENTS WITHIN THE WORK AREA UNLESS OTHERWISE NOTED. THE DEMOLITION AND REMOVAL PLAN PROVIDES OVERALL DEMOLITION SCOPE BUT MAY NOT SHOW ALL SURFACE IMPROVEMENTS TO BE REMOVED WITHIN THE WORK AREA.
 - SEE DRAWINGS L86-TMP101 THRU L86-TMP209 FOR MAINTENANCE OF TRAFFIC PHASING CONCEPTS.

- CONSTRUCTION NOTES:**
- REMOVE ASPHALT CONCRETE.
 - REMOVE CEMENT CONCRETE.
 - REMOVE CURB
 - SAWCUT EXISTING PAVEMENT
 - REMOVE BUILDING STRUCTURE.
 - REMOVE EXISTING RETAINING WALL.
 - REMOVE SIGN, POST AND FOUNDATION.
 - REMOVE CONCRETE STAIRS/RAMP, LANDING, AND METAL RAILING.
 - REMOVE TREE.
 - REMOVE TREES, LANDSCAPING AND VEGETATION IN CONTRACTOR WORK LIMITS AREA.
 - REMOVE MASONRY PLANTER AND FOUNDATION.
 - REMOVE WOODEN DECK

SEE DWG L86-CXP108

60% SUBMITTAL

DESIGNED BY:
J. MATTHEWS
 DRAWN BY:
V. RUBUSHKA
 CHECKED BY:
C. OXFORD
 APPROVED BY:
M. MORAVEC

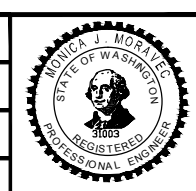

SCALE:
1" = 20'
 FILENAME:
E335-L86-CXP107
 CONTRACT No.:
RTA/LR XXXX-XX
 DATE:
12/20/2013

**EAST LINK EXTENSION
 CONTRACT E335**
 DOWNTOWN BELLEVUE TO SPRING DISTRICT
 CIVIL
 DEMOLITION AND REMOVAL PLAN
 R27 STA 36+90 TO R32 STA 101+00

DRAWING No.:
L86-CXP107
 LOCATION ID:
 SHEET No.: REV:
0

XREF LIST:
 XE335-E19-APP100
 XE335-E19-SFP100
 XE335-E19-SGP100
 XE335-L86-CAP100
 XE335-L86-KAP100
 XEL-0528r
 XEL-0528f
 XEL-0528u
 XE335-GB-TB22-04
 XE335-L86-RFP100
 XEL-0528v
 GB-SEAL-MUM31003
 XE335-L86-CCP100
 XE335-L86-CXP100
 XE335-L86-LTP100

SEE DWG L86-CXP109

SEE DWG L86-CXP111

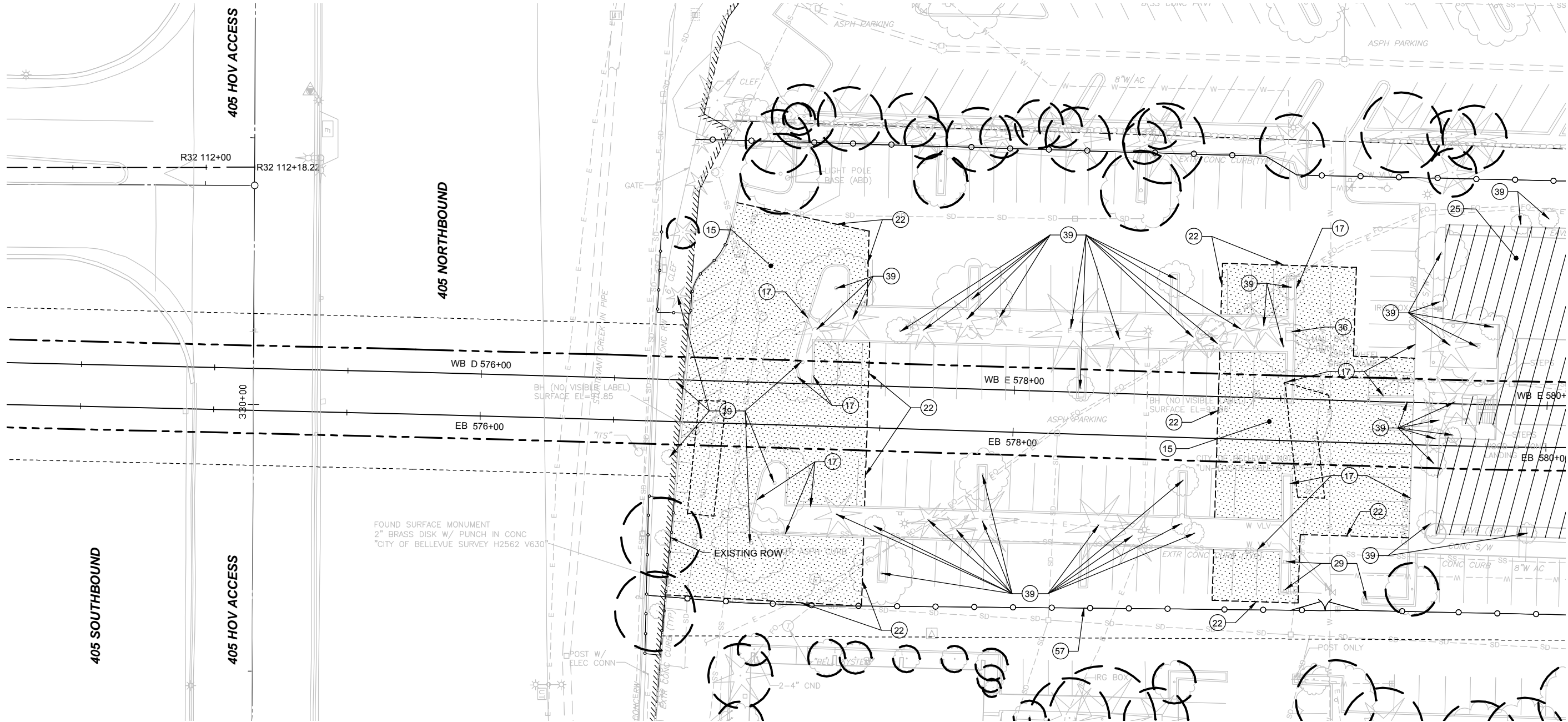

NOTES:

- SEE COMPOSITE UTILITY DRAWINGS AND DRAINAGE DRAWINGS FOR UTILITIES TO BE REMOVED AND THOSE TO REMAIN.
- SEE ILLUMINATION DRAWINGS FOR LUMINAIRES TO BE REMOVED AND THOSE TO REMAIN.
- SEE DRAWINGS L86-CCP001 THRU L86-CCP005 FOR HORIZONTAL CONTROL OF CONSTRUCTION FENCING AND CONTRACTOR STAGING AND LAYDOWN AREAS.
- REMOVE ALL EXISTING SURFACE IMPROVEMENTS WITHIN THE WORK AREA UNLESS OTHERWISE NOTED. THE DEMOLITION AND REMOVAL PLAN PROVIDES OVERALL DEMOLITION SCOPE BUT MAY NOT SHOW ALL SURFACE IMPROVEMENTS TO BE REMOVED WITHIN THE WORK AREA.
- SEE DRAWINGS L86-TMP101 THRU L86-TMP209 FOR MAINTENANCE OF TRAFFIC PHASING CONCEPTS.

CONSTRUCTION NOTES:

- (15) REMOVE ASPHALT CONCRETE.
- (17) REMOVE CURB.
- (22) SAWCUT EXISTING PAVEMENT
- (25) REMOVE BUILDING STRUCTURE.
- (29) REMOVE SIGN, POST AND FOUNDATION.
- (36) REMOVE MAILBOX.
- (39) REMOVE TREE.
- (57) INSTALL TEMPORARY CONSTRUCTION FENCING, SEE STANDARD DRAWING STD-CRD002

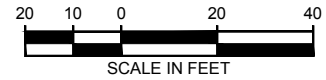

ORIGINATED BY: / DATE: /
 CHECKED BY: / DATE: /
 BACK-CHECKED BY: / DATE: /
 11/22/13 1:38 PM | RUBUSHKAV
 C:\USERS\PUBLIC\DOCUMENTS\RUBUSHKAV\H\PROJECTS\SHAREPOINT\SOUNDTRANSIT\ORIG\43\SITES\CAD\ELBEL\RED\E335\L86-CXP110.DWG

60% SUBMITTAL

DESIGNED BY:
J. MATTHEWS
 DRAWN BY:
V. RUBUSHKA
 CHECKED BY:
C. OXFORD
 APPROVED BY:
M. MORAVEC



LINE IS 1" AT FULL SCALE



SCALE:
1" = 20'
 FILENAME:
E335-L86-CXP110
 CONTRACT No.:
RTA/LR XXXX-XX
 DATE:
12/20/2013

**EAST LINK EXTENSION
 CONTRACT E335**
 DOWNTOWN BELLEVUE TO SPRING DISTRICT
 CIVIL
 DEMOLITION AND REMOVAL PLAN
 EB STA 574+50 TO EB STA 580+00

DRAWING No.:
L86-CXP110
 LOCATION ID:
 SHEET No.: REV:
 0

XREF LIST:
 XE330-E15-SFP400
 XE335-E19-APP100
 XE335-E19-SFP100
 XE335-E19-SGP100
 XE335-L86-CAP100
 XE335-L86-CAP100
 XEL-0528x
 XEL-0528f
 XEL-0528t
 XE335-CB-TB22x34
 XEL-0228vg
 XE335-L86-RPP100
 CB-SEAL-MJM1000
 XE335-L86-CCP100
 XE335-L86-CXP100
 E335-L86-CAP_C3D
 XE335-L86-LTP100
 XEL-0528vg
 XE335-L86-CPP100

ORIGINATED BY: / DATE: /
 CHECKED BY: / DATE: /
 BACK-CHECKED BY: / DATE: /
 11/22/13 1:37 PM | RUBASHKAV
 C:\USERS\PUBLIC\DOCUMENTS\ISIRUBASHKAV\PROJECTS\SHAREPOINT_SOUNDTRANSIT_ORG\43SITES\CAD\BELRED\E335\DRAWINGS\E335-L86-CXP111.DWG

CORRECTED BY: / DATE: /
 VERIFIED BY: / DATE: /

SEE DWG L86-CXP110

SEE DWG L86-CXP112

SEE DWG L86-CXP144

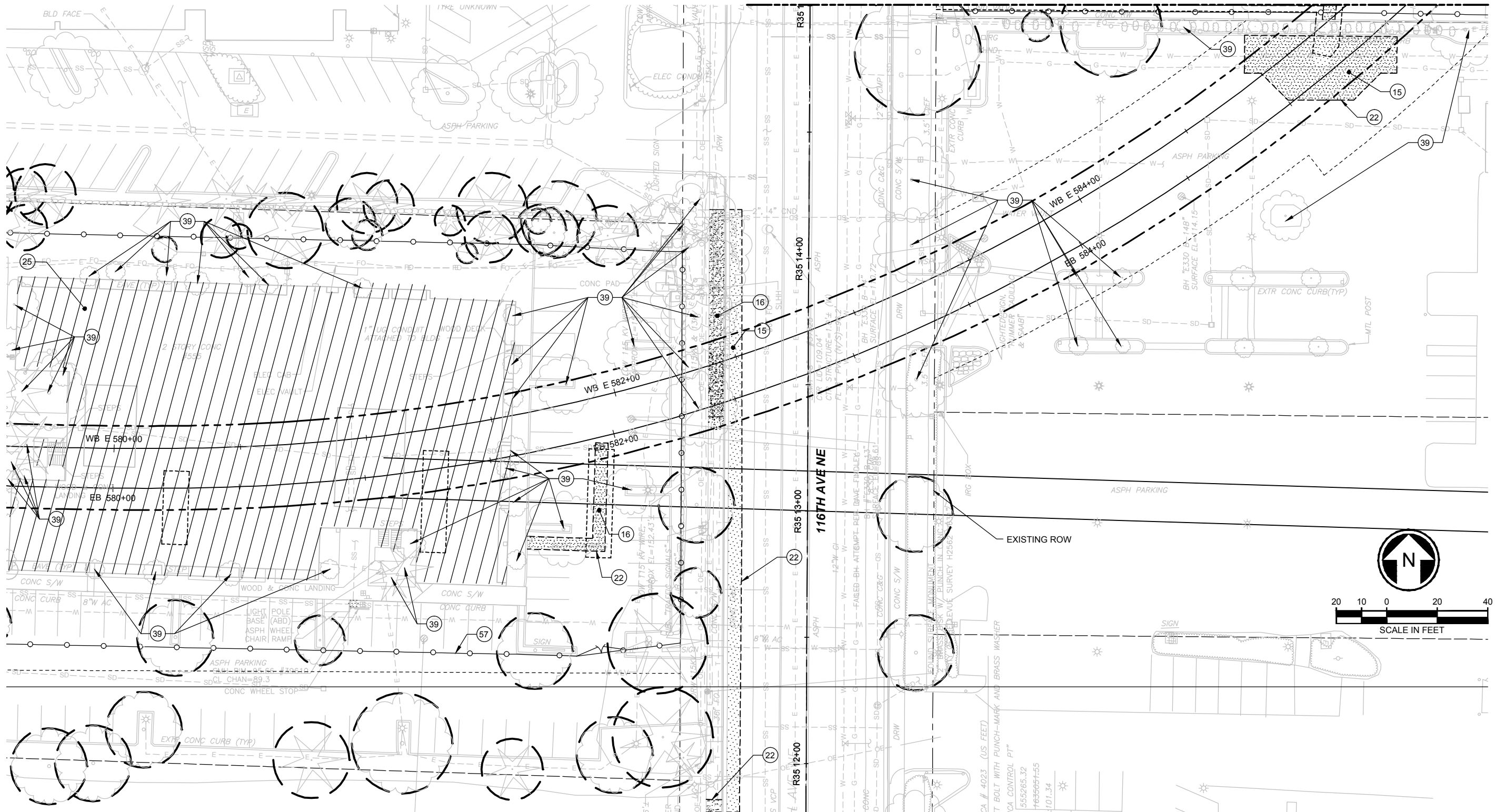

- NOTES:**
- SEE COMPOSITE UTILITY DRAWINGS AND DRAINAGE DRAWINGS FOR UTILITIES TO BE REMOVED AND THOSE TO REMAIN.
 - SEE ILLUMINATION DRAWINGS FOR LUMINAIRES TO BE REMOVED AND THOSE TO REMAIN.
 - SEE DRAWINGS L86-CCP001 THRU L86-CCP005 FOR HORIZONTAL CONTROL OF CONSTRUCTION FENCING AND CONTRACTOR STAGING AND LAYDOWN AREAS.
 - REMOVE ALL EXISTING SURFACE IMPROVEMENTS WITHIN THE WORK AREA UNLESS OTHERWISE NOTED. THE DEMOLITION AND REMOVAL PLAN PROVIDES OVERALL DEMOLITION SCOPE BUT MAY NOT SHOW ALL SURFACE IMPROVEMENTS TO BE REMOVED WITHIN THE WORK AREA.
 - SEE DRAWINGS L86-TMP101 THRU L86-TMP209 FOR MAINTENANCE OF TRAFFIC PHASING CONCEPTS.

- CONSTRUCTION NOTES:**
- (15) REMOVE ASPHALT CONCRETE.
 - (16) REMOVE CEMENT CONCRETE.
 - (22) SAWCUT EXISTING PAVEMENT
 - (25) REMOVE BUILDING STRUCTURE.
 - (39) REMOVE TREE.
 - (67) INSTALL TEMPORARY CONSTRUCTION FENCING, SEE STANDARD DRAWING STD-CRD002

60% SUBMITTAL					
No.	DATE	DSN	CHK	APP	REVISION

DESIGNED BY:
J. MATTHEWS
 DRAWN BY:
V. RUBUSHKA
 CHECKED BY:
C. OXFORD
 APPROVED BY:
M. MORAVEC

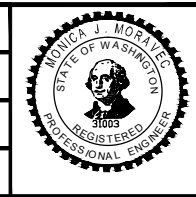

kpff
 Consulting Engineers

H J H
 FINAL DESIGN PARTNERS.

SOUNDTRANSIT

**EAST LINK EXTENSION
 CONTRACT E335**
 DOWNTOWN BELLEVUE TO SPRING DISTRICT
 CIVIL
 DEMOLITION AND REMOVAL PLAN
 EB STA 580+00 TO EB STA 585+50

DRAWING No.:
L86-CXP111
 LOCATION ID:
 SHEET No.: REV:
 0

XREF LIST:
 XE335-L86-CAP100
 XE335-L86-CMP100
 XE335-L86-KAP100
 XE335-L86-SFP100
 XE335-L86-SWP100
 XE335-L86-UCP100
 XE335-L86-CDP100
 XEL-0525x
 XEL-0525f
 XEL-0525r
 XEL-0528x
 XEL-0528f
 XEL-0528r
 XE335-GB-TB22x34
 XE335-L86-CRP100
 XE335-L86-JEP100
 XEL-0525cn
 XEL-0528cn
 XE335-E11-APP100
 XE335-L86-CMP100
 GB-SEAL-EJ448119
 XE335-E11-LSP100
 XE320-L85-KAP100
 XE320-L85-SWP100

ORIGINATED BY: / DATE: /
 CHECKED BY: / DATE: /
 CORRECTED BY: / DATE: /
 VERIFIED BY: / DATE: /
 11/04/13 | 11:24 PM | CALDWELL
 C:\USERS\PUBLIC\DOCUMENTS\CALDWELL\HNTB\SHARPOINT\SOUNDTRANSIT\ORG\443\SITES\CAD\BELLEVUE\E335\DRAWINGS\E335-L86-CMP100.DWG

END E320 CONTRACT
 BEGIN E335 CONTRACT

SEE DWG L86-CMP101

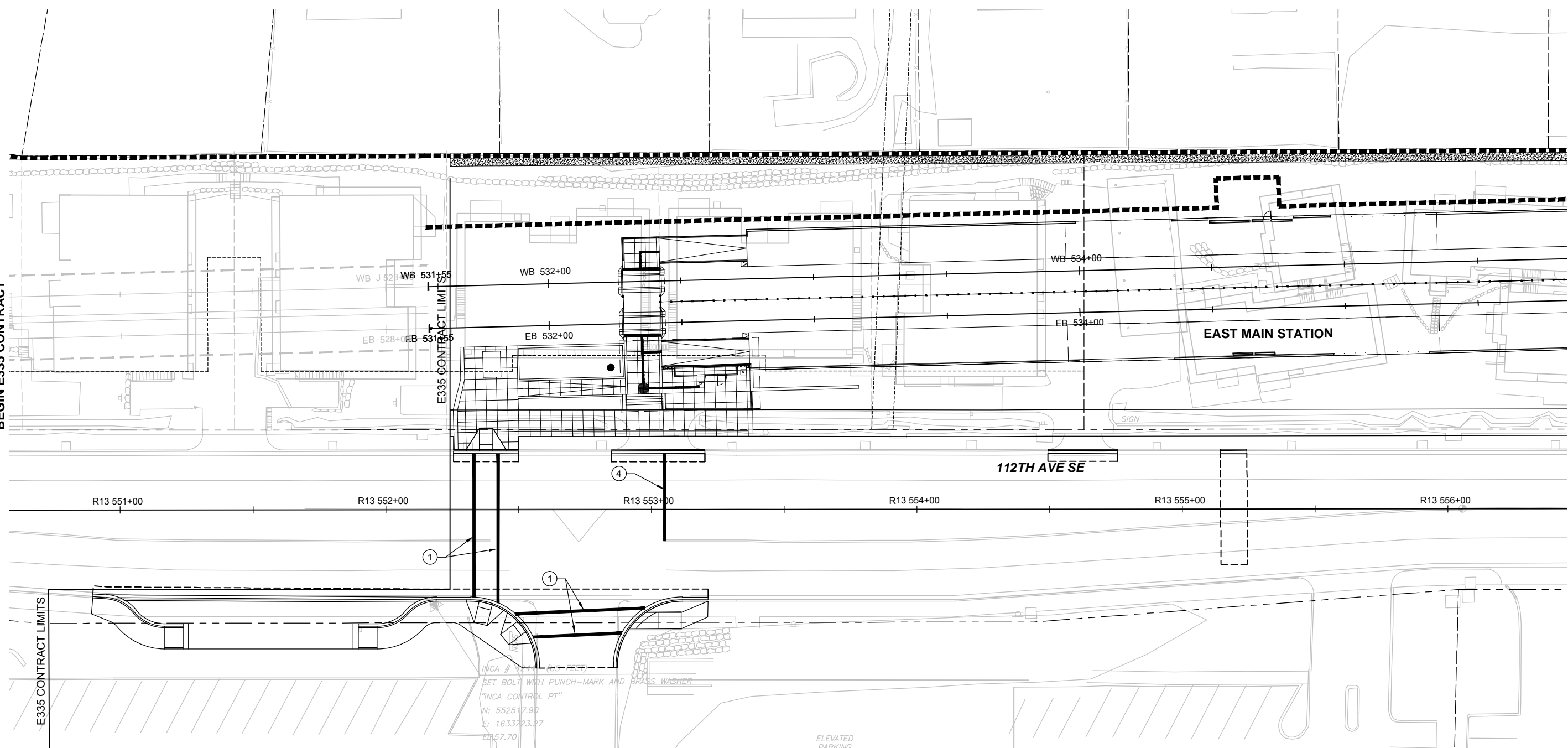

- CHANNELIZATION NOTES:**
- ① INSTALL 12" WIDE PLASTIC CROSSWALK, SEE CITY OF BELLEVUE STANDARD DRAWING TE-7.
 - ④ INSTALL 12" WIDE PLASTIC STOP LINE.

INCA # 154- (33-553)
 SET BOLT WITH PUNCH-MARK AND BRASS WASHER
 "INCA CONTROL PT"
 N: 552517.90
 E: 1633723.27
 ELEV: 57.70

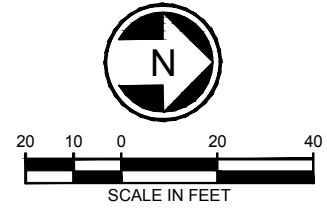

60% SUBMITTAL

DESIGNED BY:
E. ANDERS
 DRAWN BY:
R. JOHNSON
 CHECKED BY:
J. PRZYCHODZEN
 APPROVED BY:
J. SCHUTT

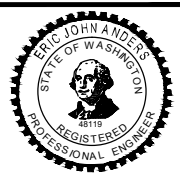

LINE IS 1" AT FULL SCALE



SCALE:
1" = 20'
 FILENAME:
E335-L86-CMP100
 CONTRACT No.:
RTA/LR XXXX-XX
 DATE:
12/20/2013

**EAST LINK EXTENSION
 CONTRACT E335**
 DOWNTOWN BELLEVUE TO SPRING DISTRICT
 CIVIL
 PAVEMENT MARKING & SIGNAGE

DRAWING No.:
L86-CMP100
 LOCATION ID:
 SHEET No.: REV:
0

No.	DATE	DSN	CHK	APP	REVISION

XREF LIST:
 XE330-E15-SFP400
 XE335-E19-APP100
 XE335-E19-SFP100
 XE335-E19-SGP100
 XE335-L86-CAP100
 XE335-L86-CMP100
 XE335-L86-KAP100
 XE335-L86-SFP100
 XEL-0228r
 XEL-0228t
 XEL-0228u
 XEL-0528r
 XEL-0528t
 XEL-0528u
 XE335-GB-TB22x34
 XE335-L86-RPP100
 XE335-L86-CGP100
 XE335-L86-CPP100
 XE335-L86-CRP100
 GB-SEAL-EJA48119

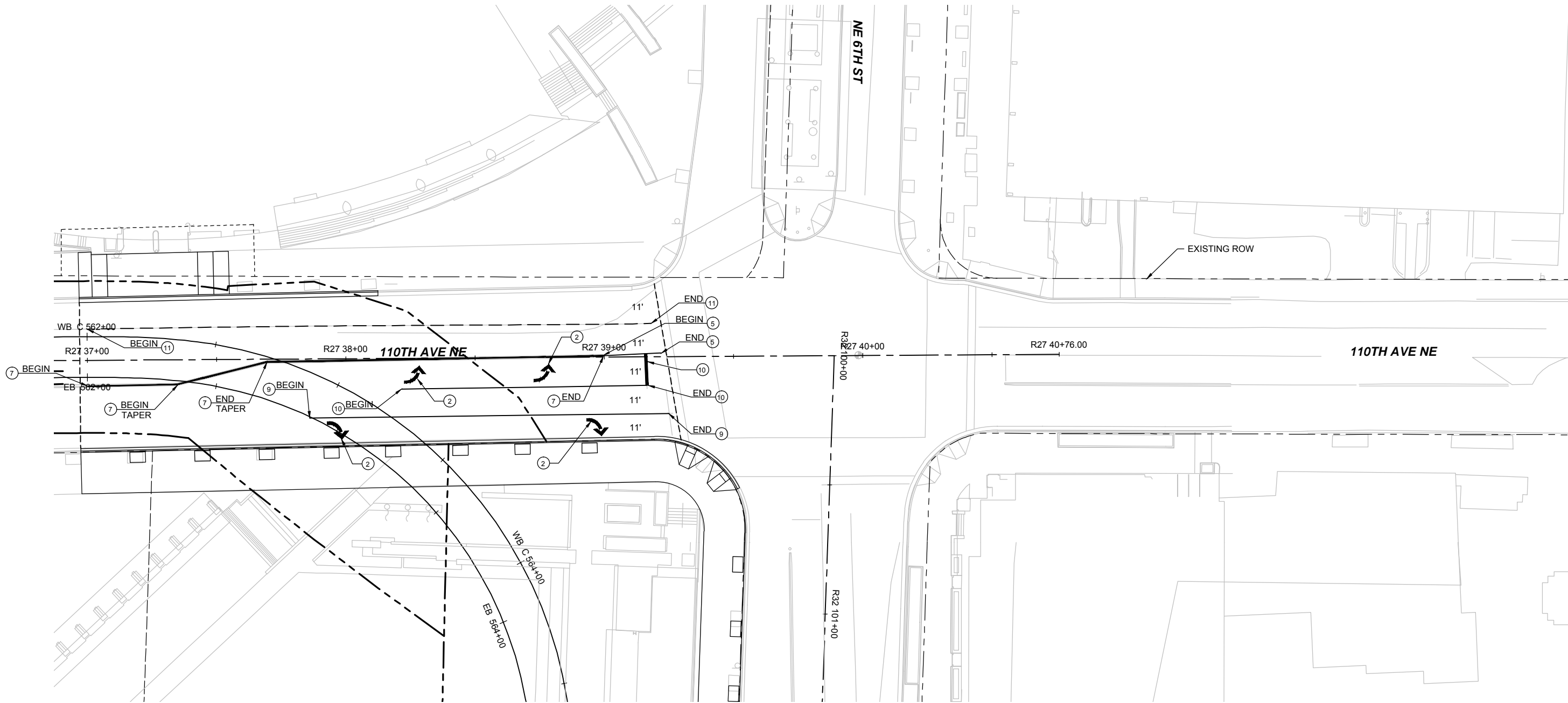

CHANNELIZATION NOTES:

- ② INSTALL PLASTIC TRAFFIC ARROW, SEE CITY OF BELLEVUE STANDARD DRAWING TE-6.
- ⑤ INSTALL DOUBLE CENTER LINE, RPMS TYPE 1Y AND 2YY (YELLOW), SEE CITY OF BELLEVUE STANDARD DRAWING TE-4A.
- ⑦ INSTALL TYPE C PAINTED YELLOW CURB.
- ⑧ INSTALL 6" WIDE PAINTED WHITE LINE.
- ⑨ INSTALL SOLID WIDE LINE, RPMS TYPE 1W AND 2W (WHITE), SEE CITY OF BELLEVUE STANDARD DRAWING TE-4A.
- ⑩ INSTALL SOLID LANE LINE, RPMS TYPE 1W AND 2W (WHITE), SEE CITY OF BELLEVUE STANDARD DRAWING TE-4A.
- ⑪ INSTALL BROKEN LANE LINE, RPMS TYPE 1W AND 2W (WHITE), SEE CITY OF BELLEVUE STANDARD DRAWING TE-4A.
- ⑫ INSTALL 12" PLASTIC WHITE STOP BAR.

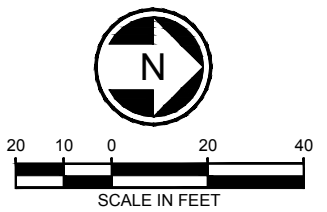

ORIGINATED BY: / DATE: /
 CORRECTED BY: / DATE: /
 VERIFIED BY: / DATE: /
 11/28/13 | 8:49 AM | CALDWELL
 BACK-CHECKED BY: / DATE: /
 C:\USERS\PUBLIC\DOCUMENTS\CALDWELL\PROJECTS\SHARPOINT\SOUNDTRANSIT\ORG\443\SITES\CAD\BELLEVUE\E335-L86-CMP107.DWG

60% SUBMITTAL

DESIGNED BY:
E. ANDERS
 DRAWN BY:
R. JOHNSON
 CHECKED BY:
J. PRZYCHODZEN
 APPROVED BY:
J. SCHUTT



LINE IS 1" AT FULL SCALE



SCALE:
1" = 20'
 FILENAME:
E335-L86-CMP107
 CONTRACT No.:
RTA/LR XXXX-XX
 DATE:
12/20/2013

**EAST LINK EXTENSION
 CONTRACT E335**
 DOWNTOWN BELLEVUE TO SPRING DISTRICT
 CIVIL
 PAVEMENT MARKING & SIGNAGE

DRAWING No.:
L86-CMP107
 LOCATION ID:
 SHEET No.: REV:
0

No.	DATE	DSN	CHK	APP	REVISION

XREF LIST:
 XE330-E15-SFP400
 XE335-E19-APP100
 XE335-E19-SFP100
 XE335-E19-SGP100
 XE335-L86-CAP100
 XE335-L86-CMP100
 XE335-L86-KAP100
 XE335-L86-SFP100
 XEL-0528R
 XEL-0528F
 XEL-0528U
 XE335-OB-TB22x34
 XE335-L86-CPP100
 XE335-L86-CGP100
 XE335-L86-CPP100
 XE335-L86-CRP100
 GB-SEAL-EJ448119

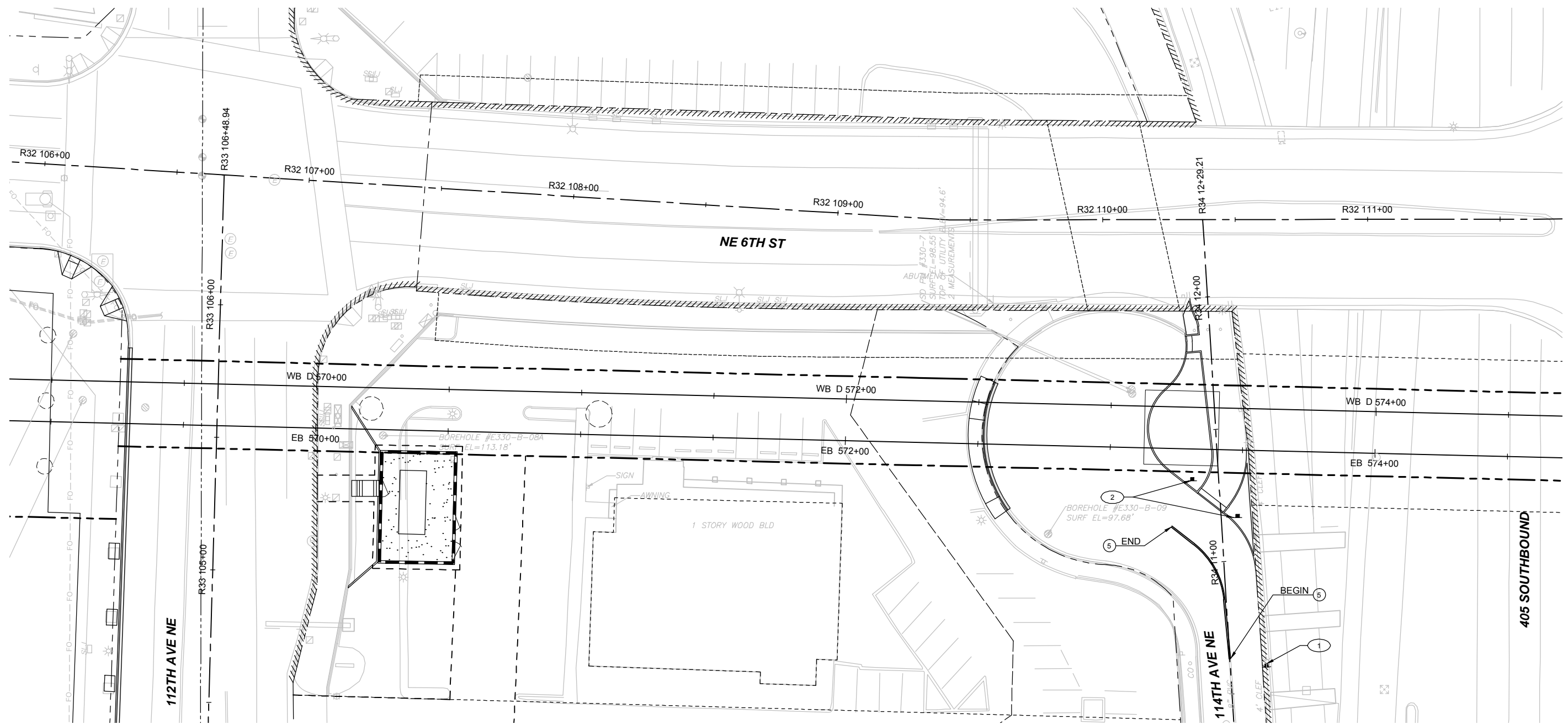

SEE DWG L86-CMP110

405 SOUTHBOUND

CHANNELIZATION NOTES:
 ⑤ INSTALL DOUBLE CENTER LINE, RPMS TYPE 1Y AND 2YY (YELLOW), SEE CITY OF BELLEVUE STANDARD DRAWING TE-4A.

SIGN SCHEDULE						
SIGN NO.	DESIGNATION	STATION	OFFSET	SIGN SIZE	POST LENGTH	REMARKS
1	W14-1			30" X 30"	N/A	INSTALL DEAD END SIGN ON EXISTING LUMINAIRE.
2	W1-8L			18" X 24"		LEFT CHEVRON SIGN, INSTALL NEW SIGN AND POST.

GENERAL SIGNING AND CHANNELIZATION NOTES:
 1. ALL SIGN DESIGNATION CODES ARE IN ACCORDANCE WITH MUTCD UNLESS OTHERWISE STATED.

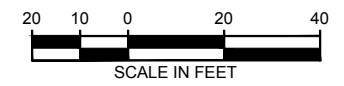

ORIGINATED BY: / DATE: /
 CHECKED BY: / DATE: /
 BACK-CHECKED BY: / DATE: /
 11/28/13 2:25 PM | CALDWELL
 C:\USERS\PUBLIC\DOCUMENTS\CALDWELL\HNTB\SHAREPOINT\SOUNDTRANSIT\DRG\443\SITES\CAD\BEL\RED\E335\L86-CMP109.DWG

60% SUBMITTAL

DESIGNED BY:
E. ANDERS
 DRAWN BY:
R. JOHNSON
 CHECKED BY:
J. PRZYCHODZEN
 APPROVED BY:
J. SCHUTT

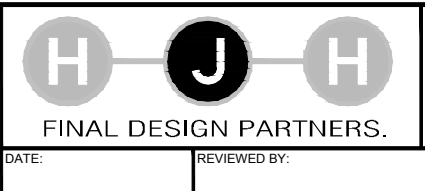

SCALE:
1" = 20'
 FILENAME:
E335-L86-CMP109
 CONTRACT No.:
RTA/LR XXXX-XX
 DATE:
12/20/2013

**EAST LINK EXTENSION
 CONTRACT E335**
 DOWNTOWN BELLEVUE TO SPRING DISTRICT
 CIVIL
 PAVEMENT MARKING & SIGNAGE

DRAWING No.:
L86-CMP109
 LOCATION ID:
 SHEET No.: REV:
0

XREF LIST:
 XE330-E15-SFP400
 XE335-E19-APP100
 XE335-E19-SGP100
 XE335-L86-CAP100
 XE335-L86-KAP100
 XE335-L86-SFP100
 XEL-0528x
 XEL-0528f
 XEL-0529f
 XEL-0531x
 XEL-0531f
 XEL-0531d
 XE335-L86-RPP100
 XE335-GB-TB22x34
 XE335-L86-CPP100
 XE335-L86-CRP100
 XE335-L86-CMP100
 XE335-E19-SFP100
 XE335-E19-LSP100
 GB-SEAL-EJ448119

ORIGINATED BY: / DATE: /
 CHECKED BY: / DATE: /
 BACK-CHECKED BY: / DATE: /
 11/22/13 1:51 PM | CALDWELL
 C:\USERS\PUBLIC\DOCUMENTS\CALDWELL\HNTB\SHARPOINT\SOUNDTRANSIT\ORG\443\SITES\CAD\ELBEL\RED\E335-L86-CMP113.DWG

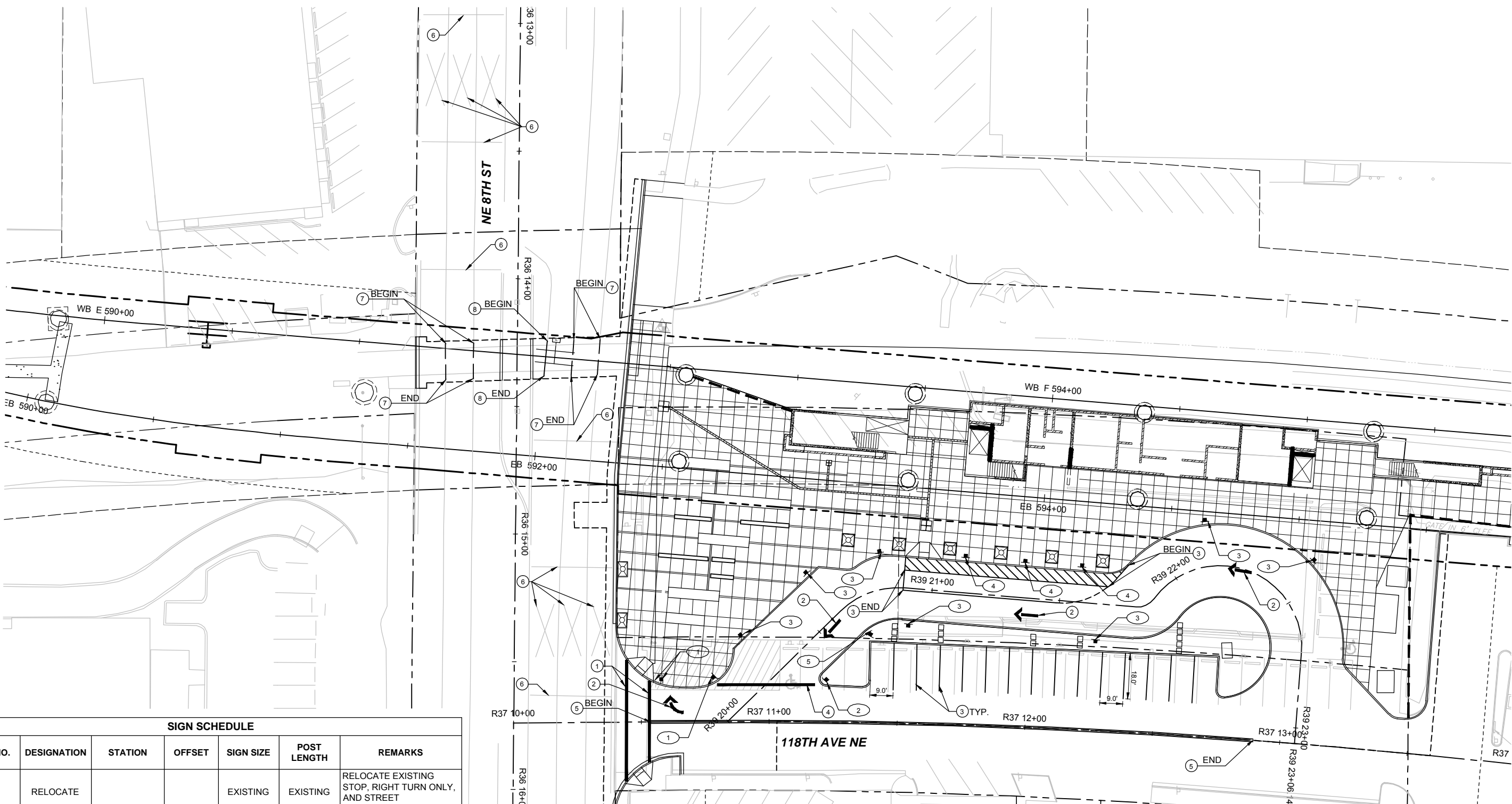

SIGN SCHEDULE

SIGN NO.	DESIGNATION	STATION	OFFSET	SIGN SIZE	POST LENGTH	REMARKS
1	RELOCATE			EXISTING	EXISTING	RELOCATE EXISTING STOP, RIGHT TURN ONLY, AND STREET DESIGNATION SIGNS.
2	R5-1			30" X 30"		DO NOT ENTER SIGN, INSTALL NEW SIGN AND POST.
3	R7-102			12" X 18"		NO PARKING SIGN, INSTALL NEW SIGN AND POST.
4	R7-6			12" X 18"		NO PARKING LOADING ZONE SIGN, INSTALL NEW SIGN AND POST.
5	R5-1a			30" X 18"		WRONG WAY, INSTALL NEW SIGN AND POST.

CHANNELIZATION NOTES:

- ① INSTALL 12" WIDE PLASTIC CROSSWALK, SEE CITY OF BELLEVUE STANDARD DRAWING TE-7.
- ② INSTALL PLASTIC TRAFFIC ARROW, SEE CITY OF BELLEVUE STANDARD DRAWING TE-6.
- ③ INSTALL 4" WIDE WHITE PAINT LINE.
- ④ INSTALL 12" WIDE PLASTIC STOP LINE.
- ⑤ INSTALL DOUBLE CENTER LINE, RPMS TYPE 1Y AND 2Y (YELLOW), SEE CITY OF BELLEVUE STANDARD DRAWING TE-4A.
- ⑥ REMOVE EXISTING PLASTIC RAILROAD GRADE CROSSING PAVEMENT MARKING.
- ⑦ INSTALL BROKEN LANE LINE, RPMS TYPE 1W AND 2W (WHITE), SEE CITY OF BELLEVUE STANDARD DRAWING TE-4A.
- ⑧ INSTALL SOLID LANE LINE, RPMS TYPE 1Y AND 2Y (YELLOW), SEE CITY OF BELLEVUE STANDARD DRAWING TE-4A.

GENERAL SIGNING AND CHANNELIZATION NOTES:

- 1. ALL SIGN DESIGNATION CODES ARE IN ACCORDANCE TO THE MUTCD UNLESS OTHERWISE STATED.

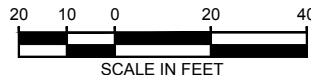

60% SUBMITTAL

DESIGNED BY:
E. ANDERS
 DRAWN BY:
R. JOHNSON
 CHECKED BY:
J. PRZYCHODZEN
 APPROVED BY:
J. SCHUTT

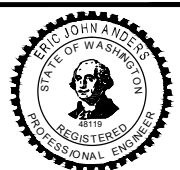

SCALE:
1" = 20'
 FILENAME:
E335-L86-CMP113
 CONTRACT No.:
RTA/LR XXXX-XX
 DATE:
12/20/2013

**EAST LINK EXTENSION
 CONTRACT E335**
 DOWNTOWN BELLEVUE TO SPRING DISTRICT
 CIVIL
 PAVEMENT MARKING & SIGNAGE

DRAWING No.:
L86-CMP113
 LOCATION ID:
SHEET No.:
REV:
0

XREF LIST:
 XE330-E15-SFP400
 XE335-E19-APP100
 XE335-E19-SFP100
 XE335-E19-SGP100
 XE335-L86-CAP100
 XE335-L86-CAP100
 XE335-L86-LPP100
 XE335-L86-SFP100
 XE335-L86-UCP100
 XE335-L86-CDP100
 XEL-0531r
 XEL-0531f
 XEL-0531t
 XE330-L86-RZV020
 XE335-L86-RPP100
 XE335-GB-TBZZ204
 XE335-L86-CGP100
 XE335-L86-CP100
 XE335-L86-CP100
 XEL-0531m
 GB-SEAL-MJM31003
 XE335-E19-LSP100
 XE335-L86-JOP100
 XE335-L86-CLP100

ORIGINATED BY: / DATE: /
 CORRECTED BY: / DATE: /
 VERIFIED BY: / DATE: /
 BACK-CHECKED BY: / DATE: /
 CALDWELL
 C:\USERS\PUBLIC\DOCUMENTS\CALDWELL\PROJECTS\SHARPOINT\ SOUNDTRANSIT\ORG\443\SITES\CAD\EL\BEL\RED\E335-L86-CGP114.DWG

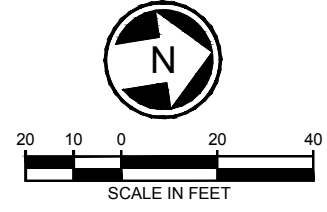

SEE DWG L86-CGP113

SEE DWG L86-CGP115

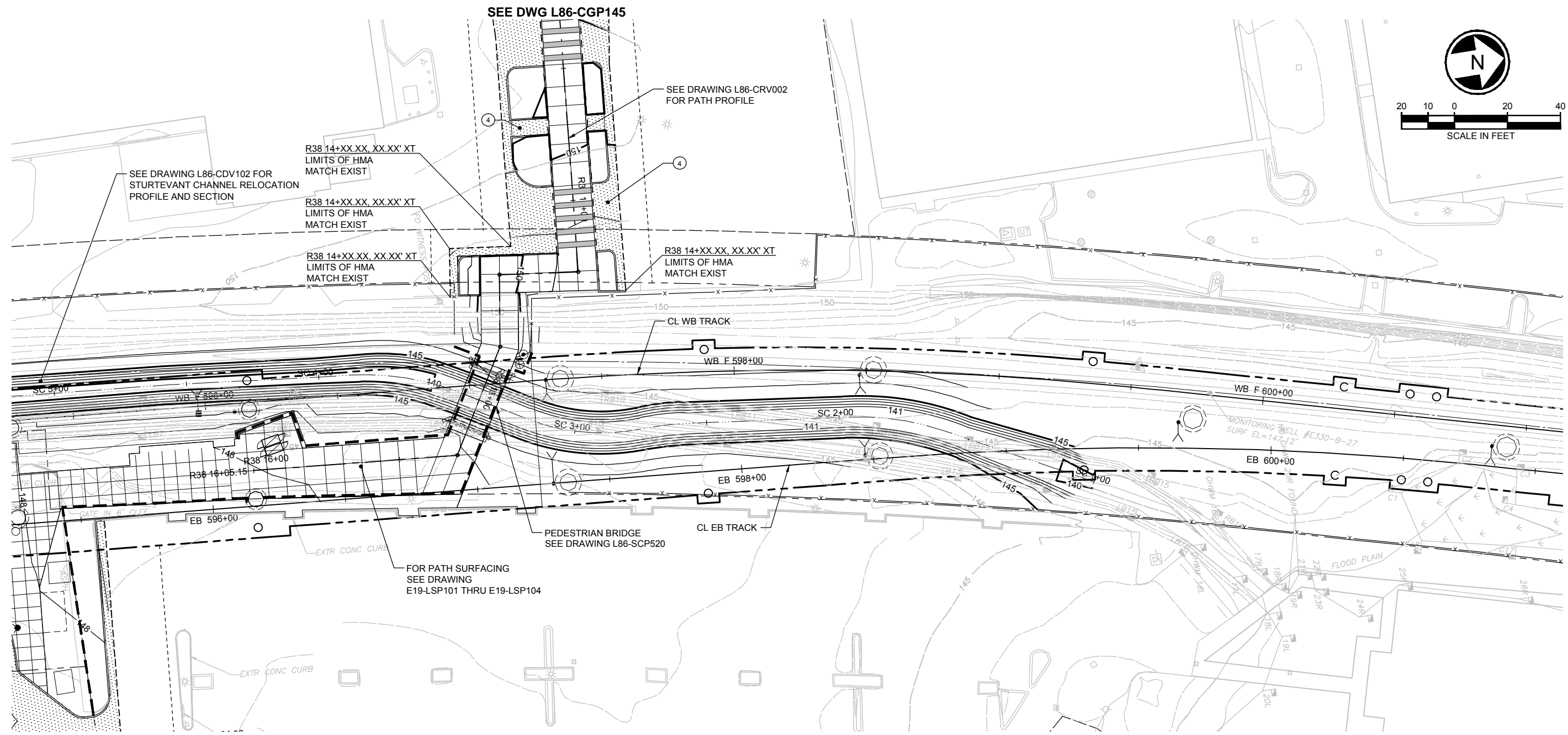

NOTES:

- FOR PAVEMENT HATCHING LEGEND, SEE SHEET L86-GZN005.
- FOR PAVEMENT SECTIONS AND MATERIALS, SEE TYPICAL SECTIONS AND PAVING AND GRADING DETAILS, CYX AND CDP SHEETS.
- SITE GRADING CONTOURS ARE SHOWN FOR CONSTRUCTION, ROADWAY CONTOURS SHOWN FOR REFERENCE ONLY AND ARE NOT FOR CONSTRUCTION.
- SEE CPD SHEETS FOR ADDITIONAL ROADWAY, SIDEWALK AND DRIVEWAY PAVING AND AND GRADING ENLARGEMENTS.
- ROADWAY WIDTHS ARE GIVEN TO FACE OF CURB, UNLESS OTHERWISE NOTED.
- ALL CURBS ARE 6 INCHES TALL UNLESS OTHERWISE NOTED.
- ELEVATIONS REFERENCE FLOW LINE OF CURB UNLESS OTHERWISE NOTED.

CONSTRUCTION NOTES:

- ④ PARKING LOT HMA PAVEMENT, SEE L86-CPD101 DETAIL B.
- ⑩ CEMENT CONCRETE SIDEWALK, SEE TYPICAL SECTIONS.

60% SUBMITTAL

DESIGNED BY:
K. IRELAND
 DRAWN BY:
J. TORR
 CHECKED BY:
J. MATTHEWS
 APPROVED BY:
M. MORAVEC



SCALE:
1" = 20'
 FILENAME:
E335-L86-CGP114
 CONTRACT No.:
RTA/LR XXXX-XX
 DATE:
12/20/2013

**EAST LINK EXTENSION
 CONTRACT E335**
 DOWNTOWN BELLEVUE TO SPRING DISTRICT
 CIVIL
 GRADING AND PAVING PLAN
 EB STA 595+0 TO EB STA 601+00

DRAWING No.:
L86-CGP114
 LOCATION ID:
 SHEET No.: REV:
0

XREF LIST:
 XE330-E15-SFP400
 XE335-E19-APP100
 XE335-E19-SFP100
 XE335-E19-SGP100
 XE335-L86-CAP100
 XE335-L86-CAP100
 XE335-L86-LPP100
 XE335-L86-SFP100
 XE335-L86-UCP100
 XE335-L86-CDP100
 XE335-L86-CDP100
 XE335-L86-RZV020
 XE335-GB-TB22x34
 XE335-L86-RPP100
 XE335-L86-CGP100
 XE335-L86-CPP100
 XE335-L86-CRP100
 XE335-L86-CRP100
 XE335-L86-CRP100
 XE335-L86-CRP100
 XE335-L86-CRP100
 XE335-L86-SWP100

ORIGINATED BY: / DATE: /
 CORRECTED BY: / DATE: /
 VERIFIED BY: / DATE: /
 11/18/13 | 9:58 AM | CALDWELL
 C:\USERS\PUBLIC\DOCUMENTS\CALDWELL\JCALDWELL\JCALDWELL\H\TTPS\SHAREPOINT\SOUNDTRANSIT\ORG\443\SITES\CAD\ELBEL\RED\E335\L86-CGP145.DWG

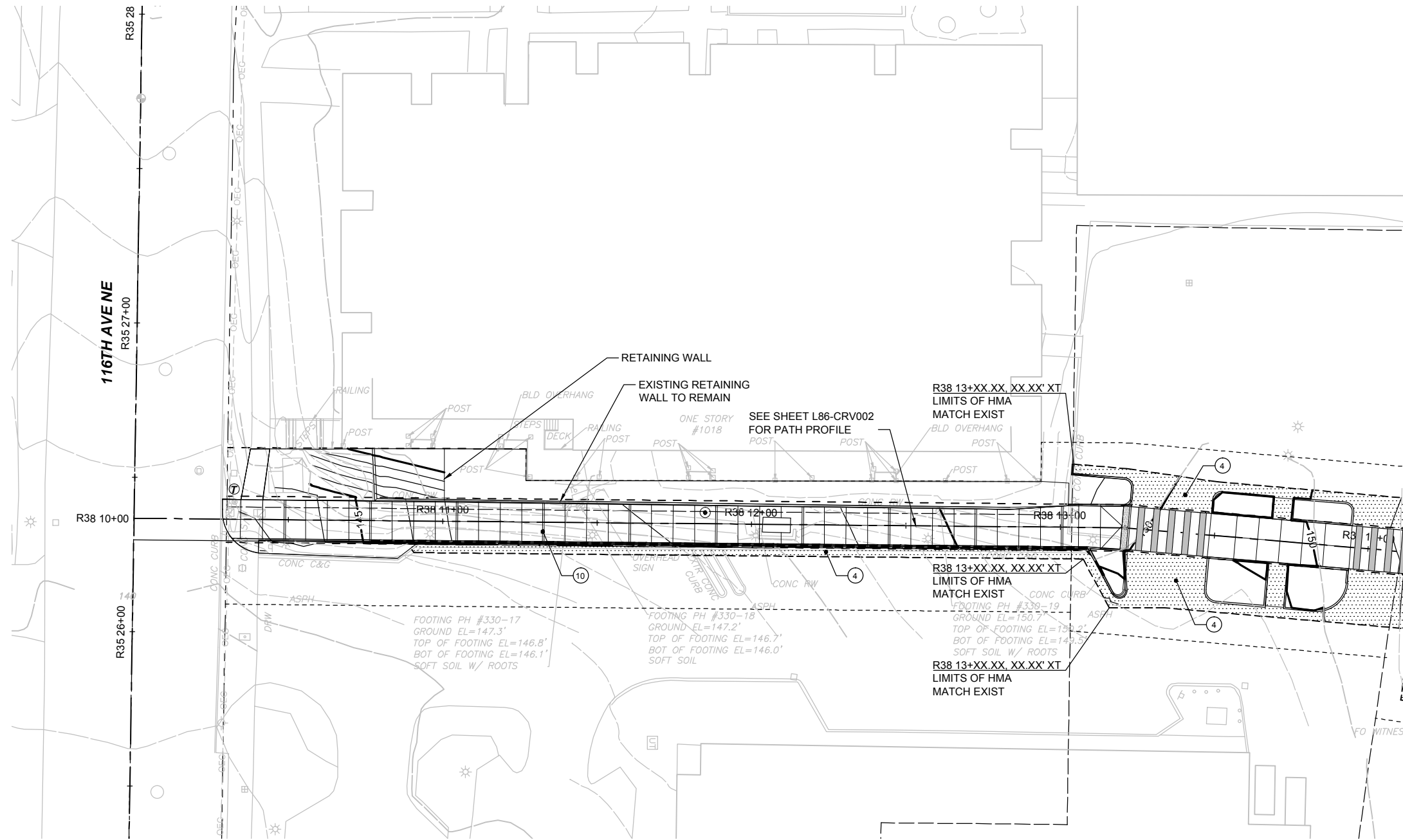

SEE DWG L86-CGP114

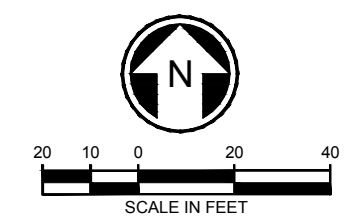

NOTES:

- FOR PAVEMENT HATCHING LEGEND, SEE SHEET L86-GZN005.
- FOR PAVEMENT SECTIONS AND MATERIALS, SEE TYPICAL SECTIONS AND PAVING AND GRADING DETAILS, CYX AND CDP SHEETS.
- SITE GRADING CONTOURS ARE SHOWN FOR CONSTRUCTION, ROADWAY CONTOURS SHOWN FOR REFERENCE ONLY AND ARE NOT FOR CONSTRUCTION.
- SEE CPD SHEETS FOR ADDITIONAL ROADWAY, SIDEWALK AND DRIVEWAY PAVING AND AND GRADING ENLARGEMENTS.
- ROADWAY WIDTHS ARE GIVEN TO FACE OF CURB, UNLESS OTHERWISE NOTED.
- ALL CURBS ARE 6 INCHES TALL UNLESS OTHERWISE NOTED.
- ELEVATIONS REFERENCE FLOW LINE OF CURB UNLESS OTHERWISE NOTED.

CONSTRUCTION NOTES:

- ④ PARKING LOT HMA PAVEMENT, SEE L86-CPD101 DETAIL B.
- ⑩ CEMENT CONCRETE SIDEWALK, SEE TYPICAL SECTIONS.

60% SUBMITTAL

DESIGNED BY:
K. IRELAND
 DRAWN BY:
J. TORR
 CHECKED BY:
J. MATTHEWS
 APPROVED BY:
M. MORAVEC



SCALE:
1" = 20'
 FILENAME:
E335-L86-CGP145
 CONTRACT No.:
RTA/LR XXXX-XX
 DATE:
12/20/2013

**EAST LINK EXTENSION
 CONTRACT E335**
 DOWNTOWN BELLEVUE TO SPRING DISTRICT
 CIVIL
 GRADING AND PAVING PLAN

DRAWING No.:
L86-CGP145
 LOCATION ID:
 SHEET No.: REV:
0

No.	DATE	DSN	CHK	APP	REVISION



XREF LIST:
 XEL-0228rx
 XEL-0228rx
 XEL-0228rf
 XEL-0228rf
 XEL-0228cn
 XEL-0228cn
 XE330-T86-STP002
 XE335-L86-KAP100
 XE330-T86-STP001
 XE335-GB-TB2x34
 XE330-T86-CRP100
 GB-SEAL-MJM31003
 XE335-L86-CCP100
 XE335-L86-CRP100
 XE330-T86-CCP100

ORIGINATED BY: / DATE: /
 CORRECTED BY: / DATE: /
 CHECKED BY: / DATE: /
 VERIFIED BY: / DATE: /
 11/22/13 | 2:41 PM | FRANKUMD
 C:\USERS\PUBLIC\DOCUMENTS\FRANKUMD\PROJECTS\SHARPOINT SOUND TRANSIT\ORIG\49\SITE\CAD\EL\BEL\RED\E335-L86-CCP001.DWG

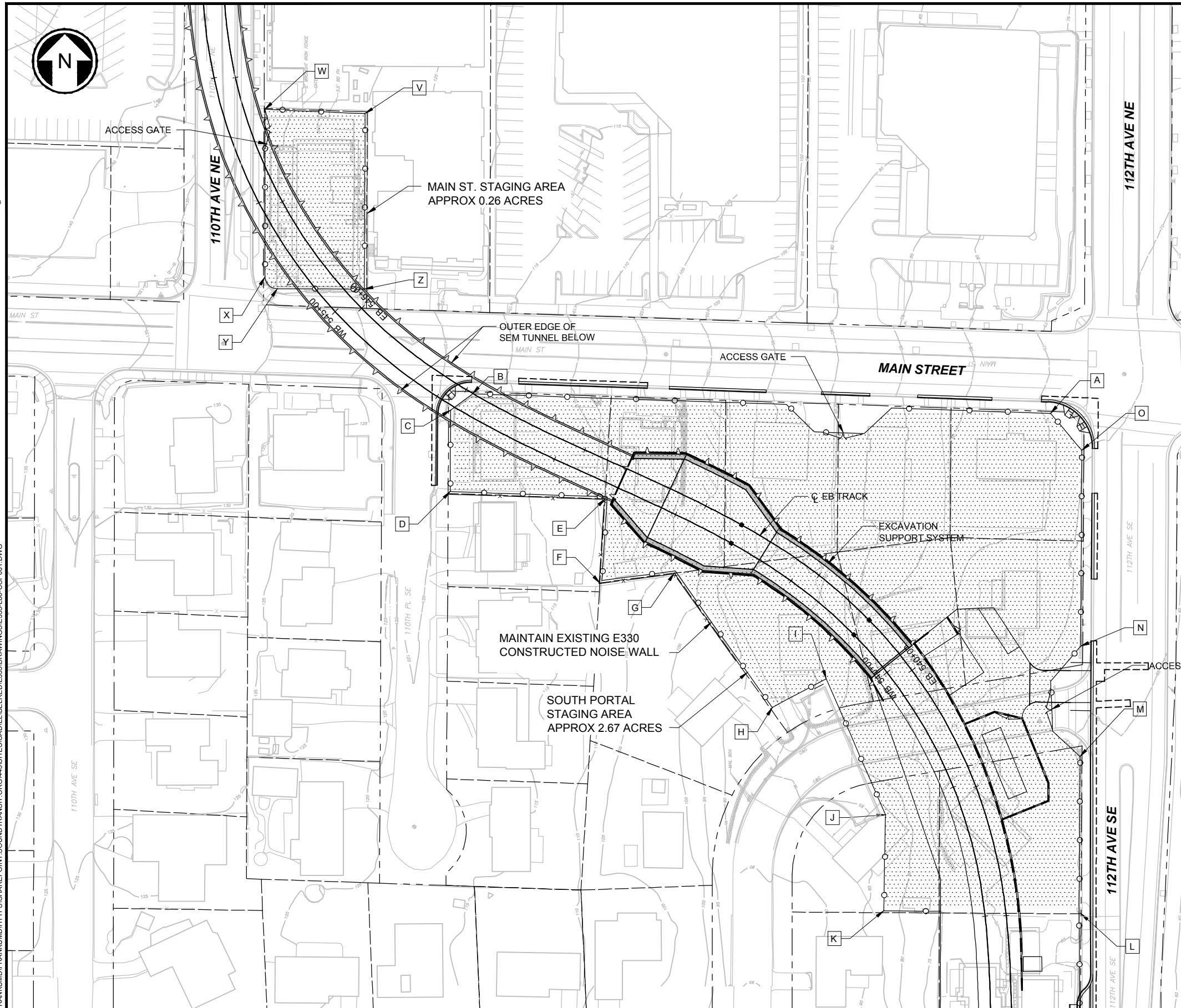

NOTES:

1. CONTRACTOR TO COMPLETELY ENCLOSE STAGING AND LAYDOWN AREAS WITH FENCING AND GATES OR MAINTAIN EXISTING FENCING AND GATES AS INDICATED. GATE LOCATIONS MAY BE MODIFIED WITH ENGINEERS APPROVAL.
2. CONTRACTOR SHALL CLEAR AND GRUB, AND REMOVE EXISTING DEBRIS, WITHIN THE LIMITS
3. PROVIDE EROSION CONTROL FOR THE CONSTRUCTION OF THE STAGING AND LAYDOWN AREA IN ACCORDANCE WITH SPECIFICATION SECTION 31 11 00. PROJECT ADJUSTMENTS SHALL BE MADE TO ADDRESS ACTUAL SITE CONDITIONS AS DIRECTED BY THE ENGINEER.
4. ALL EROSION AND SEDIMENT CONTROL MEASURES ARE TO BE PLACED PRIOR TO COMMENCEMENT OF ANY SITE WORK.
5. NOT USED.
6. SEE STORM UTILITY RELOCATION DRAWINGS FOR INLET TYPES AND SIZES.
7. FOR DISPOSITION OF EXISTING UTILITIES WITHIN THE LIMITS OF WORK, SEE UTILITY DRAWINGS.

LEGEND:

- CONTRACTOR'S STAGING AND LAYDOWN AREA (CSA)
- TEMPORARY CONSTRUCTION FENCE OR NOISE WALL, SEE L86-CXP100 THRU CXP145

POINTS	COORDINATE	
	NORTH	EAST
A		
B		
C		
D		
E		
F		
G		
H		
J		
K		
L		
M		
N		
O		
V		
W		
X		
Y		
Z		



60% SUBMITTAL

DESIGNED BY:
J. MATTHEWS
 DRAWN BY:
V. RUBUSHKA
 CHECKED BY:
C. OXFORD
 APPROVED BY:
M. MORAVEC



SCALE:
1" = 40'
 FILENAME:
E335-L86-CCP001
 CONTRACT No.:
RTA/LR XXXX-XX
 DATE:
12/20/2013

**EAST LINK EXTENSION
 CONTRACT E335**
 DOWNTOWN BELLEVUE TO SPRING DISTRICT
 CIVIL
 CONSTRUCTION STAGING AREAS
 SOUTH PORTAL

DRAWING No.:
L86-CCP001
 LOCATION ID:
 SHEET No.: REV:
0

No.	DATE	DSN	CHK	APP	REVISION



XREF LIST:
 XEL-0228rx
 XEL-0528rx
 XEL-0228rf
 XEL-0528rf
 XEL-0228cn
 XEL-0528cn
 XE330-T86-STP001
 XE335-L86-KAP100
 XE335-GB-T822-04
 GB-SEAL-MJM31003
 XE335-L86-CCP100
 XE335-L86-STP003
 XE330-T86-CCP100

NOTES:
 1. FOR NOTES SEE DRAWING L86-CCP001

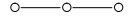
LEGEND:
 CONTRACTOR'S STAGING AND LAYDOWN AREA
 TEMPORARY CONSTRUCTION FENCE OR NOISE WALL, SEE L86-CXP100 THRU CXP145

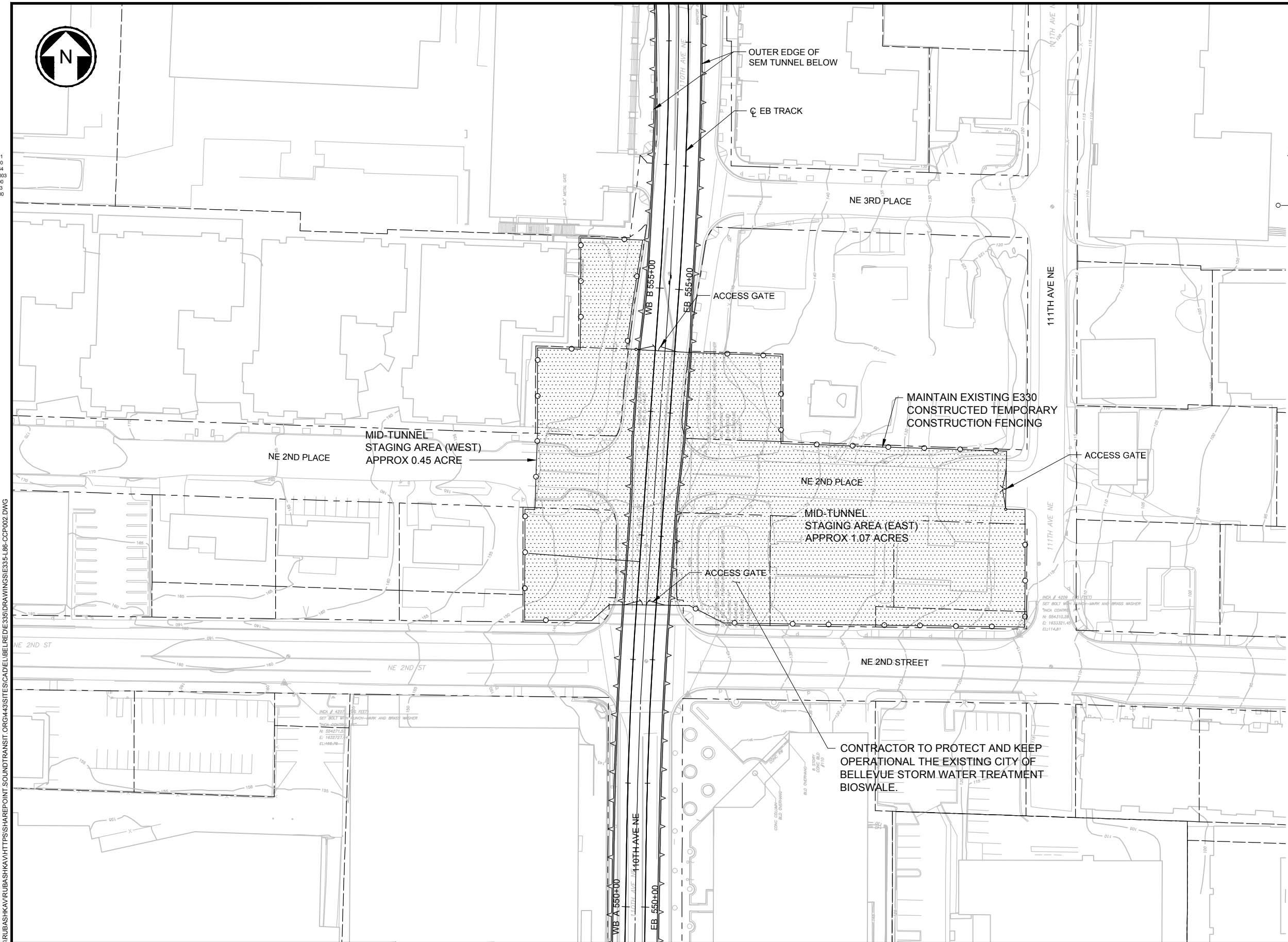

POINTS	EDGE OF CSA COORDINATE	
	NORTH	EAST
A		
B		
C		
D		
E		
F		
G		
H		
J		
K		
L		
M		
N		
P		
Q		
R		
S		
T		

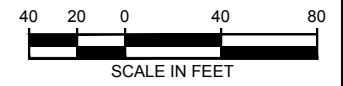

ORIGINATED BY: / DATE: /
 CHECKED BY: / DATE: /
 BACK-CHECKED BY: / DATE: /
 11/22/13 1:45 PM RUBUSHKAV
 C:\USERS\PUBLIC\DOCUMENTS\RUBUSHKAV\RUBUSHKAV\PROJECTS\CAD\BELLEVUE\DRAWINGS\E335-L86-CCP002.DWG

60% SUBMITTAL

DESIGNED BY:
J. MATTHEWS
 DRAWN BY:
V. RUBUSHKA
 CHECKED BY:
C. OXFORD
 APPROVED BY:
M. MORAVEC

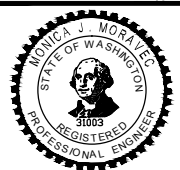

SCALE:
1" = 40'
 FILENAME:
E335-L86-CCP002
 CONTRACT No.:
RTA/LR XXXX-XX
 DATE:
12/20/2013

**EAST LINK EXTENSION
 CONTRACT E335**
 DOWNTOWN BELLEVUE TO SPRING DISTRICT
 CIVIL
 CONSTRUCTION STAGING AREAS
 MID-TUNNEL

DRAWING No.:
L86-CCP002
 LOCATION ID:
 SHEET No.: REV:
0

No.	DATE	DSN	CHK	APP	REVISION



XREF LIST:
 XEL-0228rx
 XEL-0228lx
 XEL-0228rf
 XEL-0528af
 XEL-0228cn
 XEL-0528cn
 XE330-T86-STP001
 XE335-L86-KAP100
 U:\BelRed\E335\Xref\XE335-L86-CCP003-DWG
 GB-SEAL-MJM31003
 U:\BelRed\E335\Xref\XE335-L86-CCP100
 U:\BelRed\E335\Xref\XE335-L86-STP003

INCH # 4007 (US FEET)
 SET BOLT WITH PUNCH-MARK
 AND BRASS WASHER
 TECH CONTROL P11
 NO. 200531.86
 E: 1633087.34
 E1:160.22

NOTES:

1. FOR NOTES SEE DRAWING L86-CCP001

LEGEND:



CONTRACTOR'S STAGING AND LAYDOWN AREA

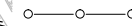

TEMPORARY CONSTRUCTION FENCE OR NOISE WALL, SEE L86-CXP100 THRU CXP145

POINTS	EDGE OF CSA COORDINATE	
	NORTH	EAST
A		
B		
C		
D		
E		
F		
G		
H		
J		
K		
L		
M		
N		
P		
Q		

ORIGINATED BY: / DATE: /
 CHECKED BY: / DATE: /
 CORRECTED BY: / DATE: /
 VERIFIED BY: / DATE: /
 11/20/13 | 2:19 PM | RUBUSHKA
 C:\USERS\PUBLIC\DOCUMENTS\RUBUSHKA\RUBUSHKA\HITTPS\SHAREPOINT\SOUNDTRANSIT.ORG\443\SITES\CAD\EL\BELRED\E335\DRAWINGS\E335-L86-CCP003.DWG

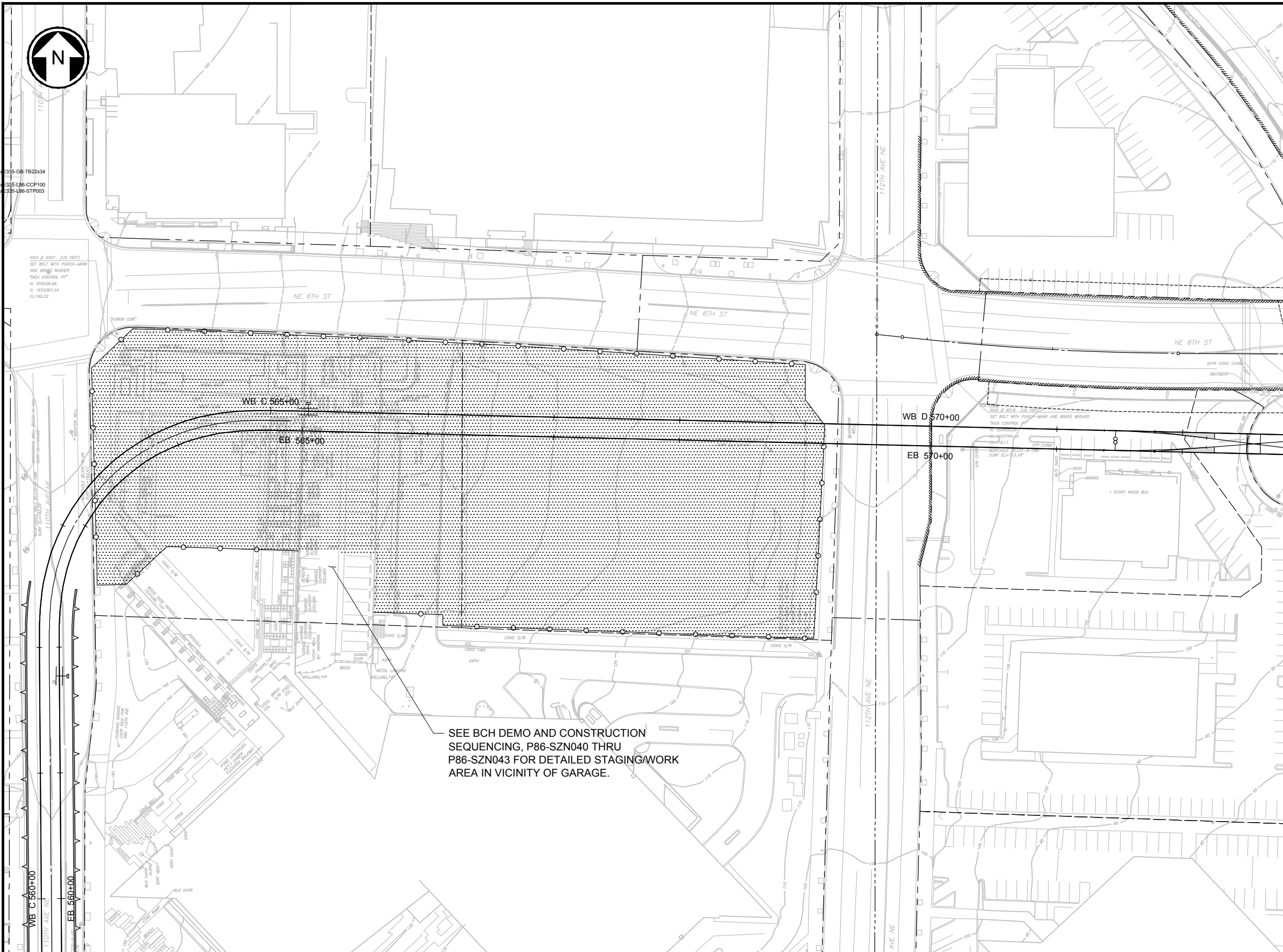

SEE BCH DEMO AND CONSTRUCTION SEQUENCING, P86-SZN040 THRU P86-SZN043 FOR DETAILED STAGING/WORK AREA IN VICINITY OF GARAGE.

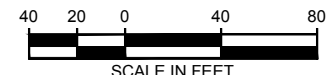

60% SUBMITTAL

DESIGNED BY:
J. MATTHEWS
 DRAWN BY:
V. RUBUSHKA
 CHECKED BY:
C. OXFORD
 APPROVED BY:
M. MORAVEC



SCALE:
1" = 40'
 FILENAME:
E335-L86-CCP003
 CONTRACT No.:
RTA/LR XXXX-XX
 DATE:
12/20/2013

**EAST LINK EXTENSION
 CONTRACT E335**
 DOWNTOWN BELLEVUE TO SPRING DISTRICT
 CIVIL
 CONSTRUCTION STAGING AREAS
 NORTH PORTAL / BTC STATION

DRAWING No.:
L86-CCP003
 LOCATION ID:
 SHEET No.: REV:
 0



No.	DATE	DSN	CHK	APP	REVISION



XREF LIST:
 XEL-0228rx
 XEL-0228rx
 XEL-0228rf
 XEL-0228rf
 XEL-0228cn
 XEL-0228cn
 XE330-T86-STP001
 XE335-L86-KAP100
 XE335-GB-T822-04
 GB-SEAL-MJM31003
 XE335-L86-CCP100
 XE335-L86-STP003

ORIGINATED BY: / DATE: /
 CHECKED BY: / DATE: /
 CORRECTED BY: / DATE: /
 VERIFIED BY: / DATE: /
 11/22/13 | 2:46 PM | FRANKUMD
 C:\USERS\PUBLIC\DOCUMENTS\FRANKUMD\PROJECTS\SHARPOINT\SOUNDTRANSIT\ORG\49\SITES\CAD\EL\BEL\RED\E335-L86-CCP004.DWG

NOTES:
 1. FOR NOTES SEE DRAWING L86-CCP001

LEGEND:
 CONTRACTOR'S STAGING AND LAYDOWN AREA
 TEMPORARY CONSTRUCTION FENCE OR NOISE WALL, SEE L86-CXP100 THRU CXP145

POINTS	EDGE OF CSA COORDINATE	
	NORTH	EAST
A		
B		
C		
D		
E		
F		
G		
H		

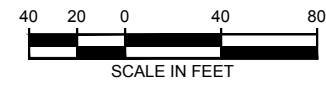
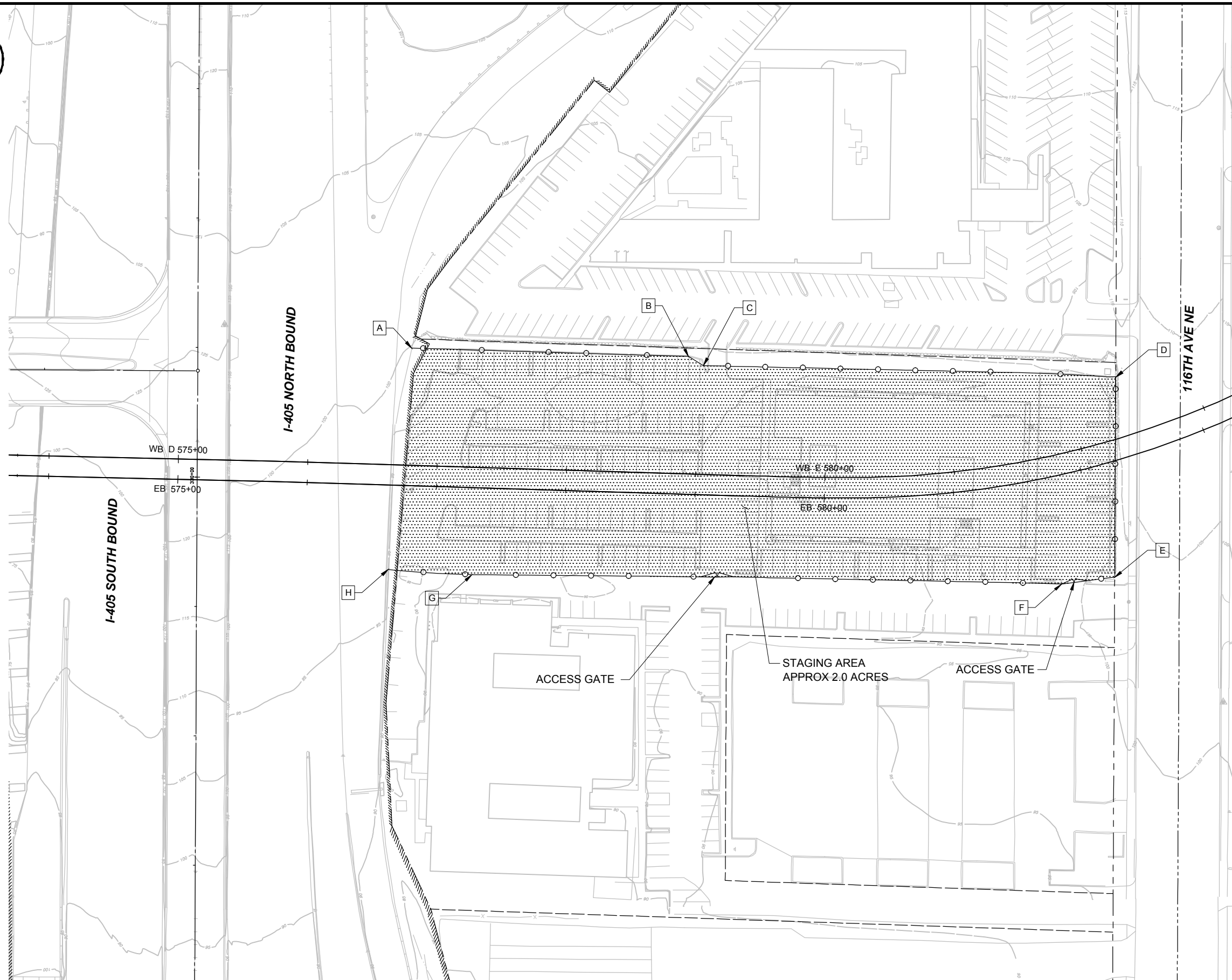

60% SUBMITTAL

DESIGNED BY:
J. MATTHEWS
 DRAWN BY:
V. RUBUSHKA
 CHECKED BY:
C. OXFORD
 APPROVED BY:
M. MORAVEC

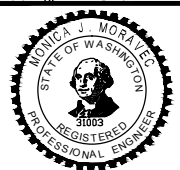

SCALE:
1" = 40'
 FILENAME:
E335-L86-CCP004
 CONTRACT No.:
RTA/LR XXXX-XX
 DATE:
12/20/2013

**EAST LINK EXTENSION
 CONTRACT E335**
 DOWNTOWN BELLEVUE TO SPRING DISTRICT
 CIVIL
 CONSTRUCTION STAGING AREAS
 WEST OF 116TH AVE NE

DRAWING No.:
L86-CCP004
 LOCATION ID:
 SHEET No.: REV:
0



No.	DATE	DSN	CHK	APP	REVISION



XREF LIST:
 XEL-0228rx
 XEL-0528rx
 XEL-0228rf
 XEL-0528rf
 XEL-0228cn
 XEL-0528cn
 XE330-T86-STP001
 XE335-L86-KAP100
 XE335-GB-T822-04
 GB-SEAL-MJM31003
 XE335-L86-CCP100
 XE335-L86-STP003



NOTES:
 1. FOR NOTES SEE DRAWING L86-CCP001

LEGEND:
 CONTRACTOR'S STAGING AND LAYDOWN AREA
 TEMPORARY CONSTRUCTION FENCE OR NOISE WALL. SEE L86-CXP100 THRU CXP145

POINTS	EDGE OF CSA	
	COORDINATE	
	NORTH	EAST
A		
B		
C		
D		
E		
F		
G		
H		

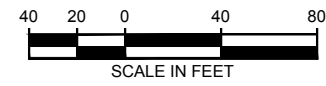

ORIGINATED BY: / DATE: /
 CHECKED BY: / DATE: /
 BACK-CHECKED BY: / DATE: /
 C:\USERS\PUBLIC\DOCUMENTS\FRANKUM\DRAWINGS\SHARPPOINT SOUND TRANSIT\ORG44\3\1\TES\CAD\EL\BEL\RED\E335-L86-CCP005.DWG

60% SUBMITTAL

DESIGNED BY:
J. MATTHEWS
 DRAWN BY:
V. RUBUSHKA
 CHECKED BY:
C. OXFORD
 APPROVED BY:
M. MORAVEC

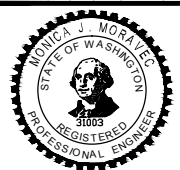

LINE IS 1" AT FULL SCALE



SCALE:
1" = 40'
 FILENAME:
E335-L86-CCP005
 CONTRACT No.:
RTA/LR XXXX-XX
 DATE:
12/20/2013

**EAST LINK EXTENSION
 CONTRACT E335**
 DOWNTOWN BELLEVUE TO SPRING DISTRICT
 CIVIL
 CONSTRUCTION STAGING AREAS
 EAST OF 116TH AVE NE

DRAWING No.:
L86-CCP005
 LOCATION ID:
 SHEET No.: REV:
0

No.	DATE	DSN	CHK	APP	REVISION

XREF LIST:
 XE335-L86-CMP100
 XE335-L86-CSP100
 XE335-L86-SFP100
 XE335-L86-CDP100
 XEL-0525x
 XEL-0525f
 XEL-0525u
 XEL-0528x
 XEL-0528f
 XEL-0528u
 XE335-GB-TR22x34
 XE335-E11-APP100
 XE330-T86-STP001
 XE330-T86-STP002
 XE335-L86-CAP100
 XE330-L85-CAP100
 CB-SEAL-SAK37866
 XE335-L86-KAP100
 XE330-L85-CRP100
 XE335-L86-MPP100
 XE335-L86-RFP100
 XE335-L86-UCP100
 XE335-L86-SWP100
 XE335-L86-GZV020
 XE335-L86-CLP100
 XE335-L86-CRP100
 XE335-L86-EFP100
 XE335-L86-EFP300
 XE335-L86-JEP100
 XE335-L86-JOP100
 XE335-L86-TSP100

ORIGINATED BY: / DATE: /
 CORRECTED BY: / DATE: /
 VERIFIED BY: / DATE: /
 11/26/13 | 3:28 PM | CALDWELL
 BACK-CHECKED BY: / DATE: /
 C:\USERS\PUBLIC\DOCUMENTS\CALDWELL\PROJECTS\SHARPOINT\SOUNDTRANSIT\ORG\443\SITES\CAD\BELRED\E335\L86-UCP100.DWG

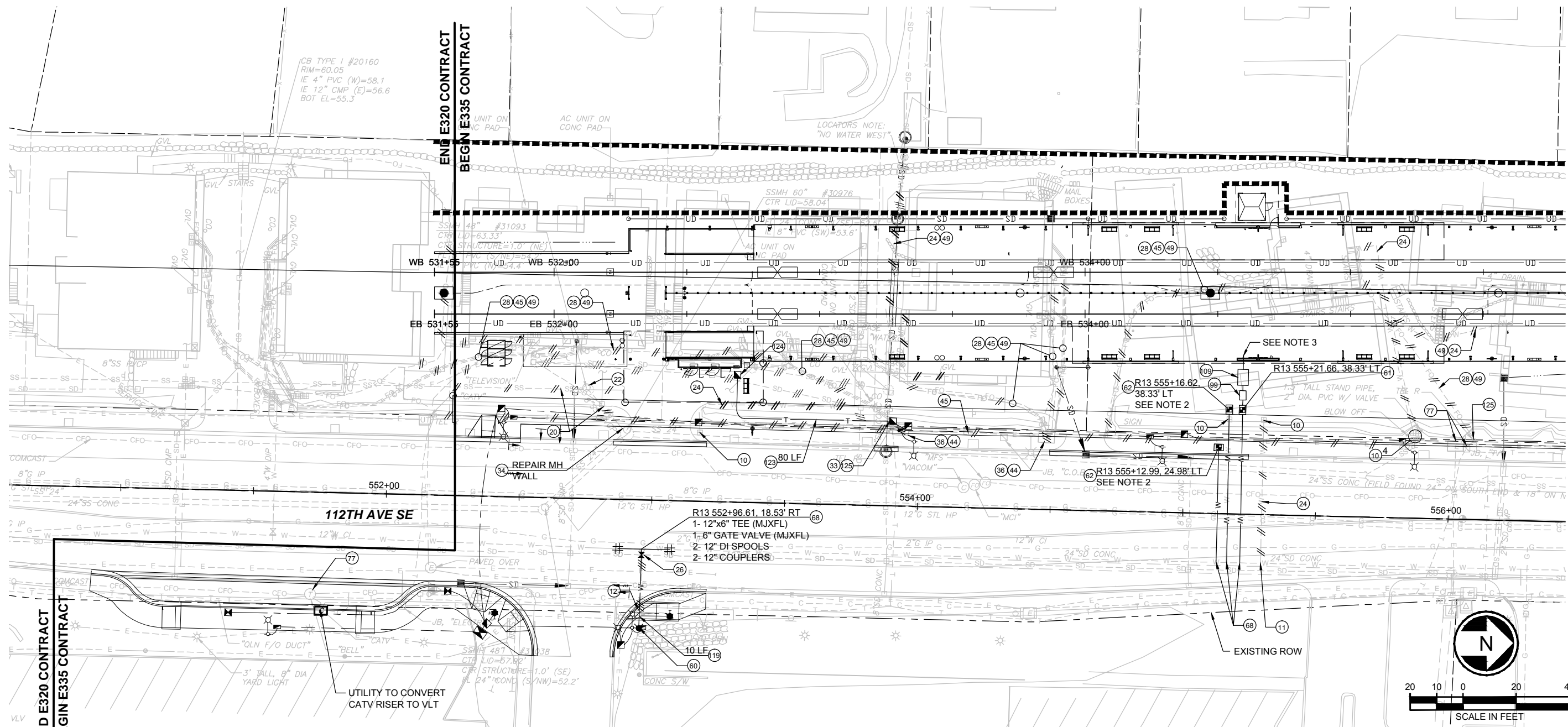

SEE DWG L86-UCP101

NOTES:

- SEE NOTES UZN001 FOR DISCONNECTION / ABANDONMENT / REMOVAL OF UTILITY SERVICES AT BUILDINGS TO BE DEMOLISHED.
- SEE EAST MAIN STATION LANDSCAPING DRAWINGS FOR CONTINUATION.
- SEE EAST MAIN STATION MECHANICAL PLUMBING DRAWINGS FOR CONTINUATION.

CONSTRUCTION NOTES:

- (10) RMV EXIST METER BOX
- (11) RMV SVC CONNECT AND REPAIR
- (12) RMV HYD
- (20) ABD SS MAIN. FILL W/CDF
- (21) ABD SANITARY SIDE SEWER FILL W/CDF
- (22) ABD SS MH RMV TO 6FT BELOW FINISH GRADE
- (24) ABD WATER SVC.
- (26) RMV EXIST VALVE
- (28) UTIL TO ABD TELECOMM SRV, NIC.
- (33) UTIL TO CONST TELECOMM VLT, NIC.
- (34) RECHANNEL EXIST MH.
- (36) RMV POWER VLT/JB.
- (44) PSE TO ABD ELEC VLT/ JB, NIC.
- (45) PSE TO ABD ELEC SVC, NIC.
- (49) CONTRACTOR TO RMV ABD FACILITY W/I EXC LIMITS.
- (80) CONST HYD PER COB STD PLAN W-13.
- (81) CONST 1.5" DOM WATER SVC PER COB STD PLAN W-26.
- (82) CONST 1.5" IRRIG WATER SVC PER COB STD PLAN W-28.
- (86) CONNECT TO EXIST WM.
- (77) ADJ VLT TO FG JUST PRIOR TO PAVING.
- (99) CONST PRV PER COB STD PLAN W-21.
- (109) CONST DCVA PER COB STD PLAN W-41.
- (19) CONST 6" DI
- (23) CONST 2-2" PVC CONDUIT (STATION PROVISIONS FOR PUBLIC PHONE SERVICE)
- (24) CONST TELECOM VLT/JB
- (25) RMV TELECOM RISER BOX

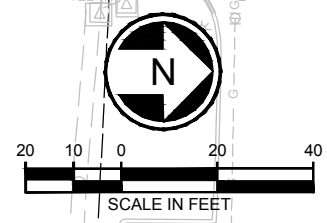

60% SUBMITTAL

DESIGNED BY:
B. NELSON
 DRAWN BY:
D. FRANKUM
 CHECKED BY:
J. WEBER
 APPROVED BY:
J. SCHUTT



The VOSK Group LLP
 Project and Construction Management Consultants

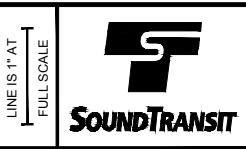
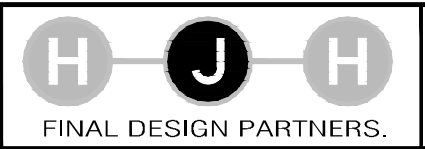

SCALE:
1" = 20'
 FILENAME:
E335-L86-UCP100
 CONTRACT No.:
RTA/LR XXXX-XX
 DATE:
12/20/2013

**EAST LINK EXTENSION
 CONTRACT E335**
 DOWNTOWN BELLEVUE TO SPRING DISTRICT
 COMPOSITE UTILITY
 PLAN
 EB STA 531+00 TO EB STA 536+00

DRAWING No.:
L86-UCP100
 LOCATION ID:
 SHEET No.: REV:
0

XREF LIST:
 XE335-L86-CMP100
 XE335-L86-CSP100
 XE335-L86-LPP100
 XE335-L86-SFP100
 XE335-L86-CDP100
 XEL-0525x
 XEL-0525uf
 XEL-0528uf
 XEL-0528uf
 XEL-0528uf
 XE320-L85-KAP100
 XE335-09-TR22-24
 XE335-E11-APP100
 XE335-L86-CRP100
 XE330-T86-STP001
 XE335-L86-CAP100
 XE320-L85-CAP100
 GB-SEAL-SAK37896
 XE335-L86-KAP100
 XE320-L85-CRP100
 XE335-L86-MPP100
 XE335-L86-RPP100
 XE335-L86-TSP100
 XE335-L86-SWP100
 XE335-L86-CLP100
 XE335-L86-JOP100
 XE335-L86-JEP100
 XE330-T86-CDP100
 XE335-L86-EPP300
 XE335-E11-EPP100
 XE330-T86-STP002
 XE330-T86-SWP100

ORIGINATED BY: / DATE: /
 CHECKED BY: / DATE: /
 BACK-CHECKED BY: / DATE: /
 11/19/13 | 10:37 AM | FRANKUM
 C:\USERS\PUBLIC\DOCUMENTS\FRANKUM\DRAWINGS\E335-L86-UCP101.DWG

CORRECTED BY: / DATE: /
 VERIFIED BY: / DATE: /

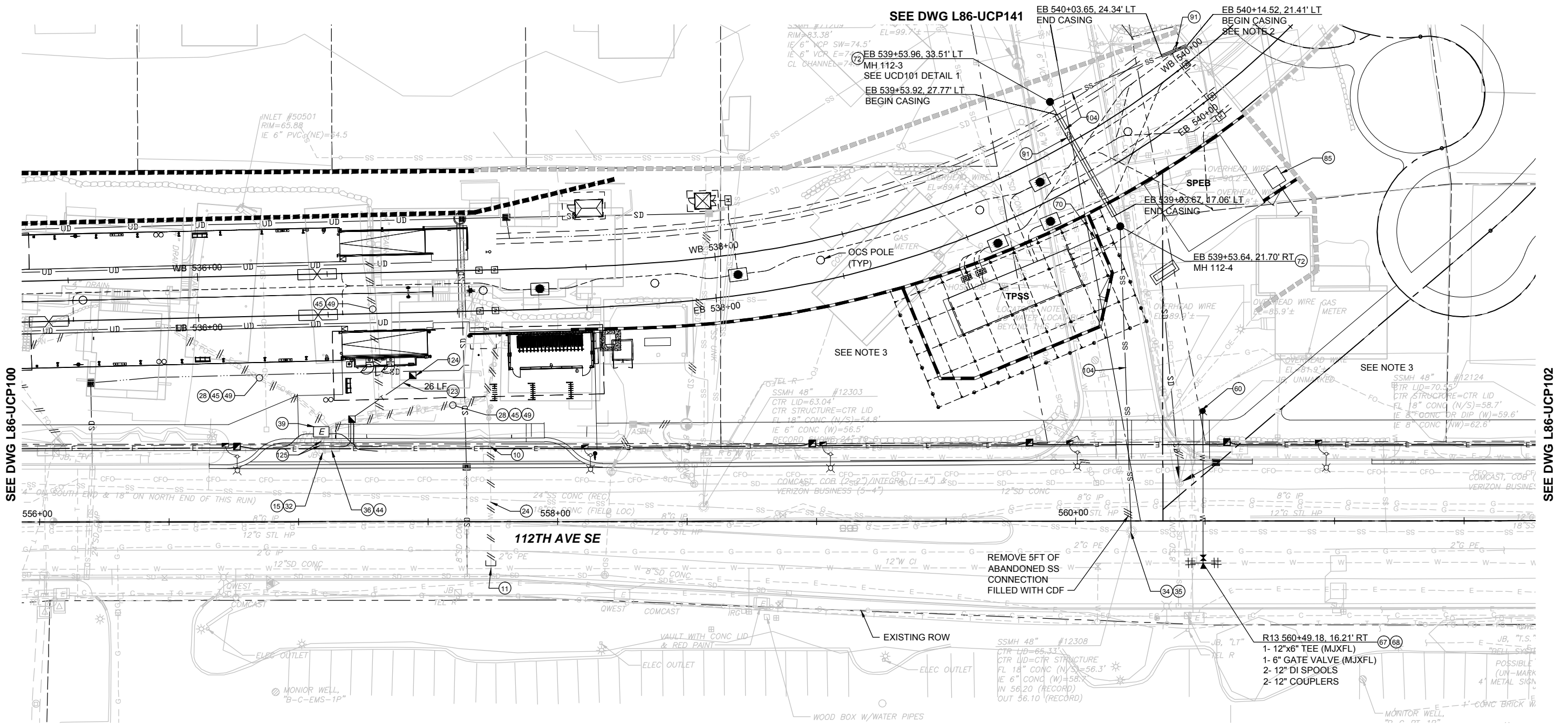

NOTES:

- SEE NOTES UZN001 FOR DISCONNECTION / ABANDONMENT / REMOVAL OF UTILITY SERVICES AT BUILDINGS TO BE DEMOLISHED.
- CONNECT 12" PVC SS AT TUNNEL FACE TO 8" SS STUB OUT. SEE MECHANICAL PLUMBING DRAWING FOR CONTINUATION.
- E330 CONTRACTOR HAS DEMOLISHED UTILITIES WITHIN THIS AREA.

CONSTRUCTION NOTES:

- | | |
|--|---|
| (10) RMV EXIST METER BOX | (60) CONST PER COB STD PLAN W-13. |
| (11) RMV SVC CONNECT AND REPAIR | (67) CONST CONC TB PER COB STD PLAN W-1. |
| (15) RMV COMM VAULT | (68) CONNECT TO EXIST WM. |
| (24) ABD WATER SVC. | (70) CONST 6" SIDE SEWER. |
| (26) UTIL TO ABD TELECOMM SRV, NIC | (72) CONST STD MH PER COB STD PLAN S-1. |
| (32) UTIL TO ABD TELECOMM VLT/JB | (85) PSE TO CONST POWER SVC, NIC. |
| (34) RECHANNEL EXIST MH | (91) CONST CASING PER COB STD PLAN SS-33. |
| (35) CONNECT TO EXIST MH | (104) CONST 12" PVC SS. |
| (36) RMV POWER VLT/JB. | (123) CONST 12" PVC SS. |
| (39) PSE TO CONST VLT/JB, NIC. | (124) CONN TO EXIST SS MAIN. |
| (40) PSE TO ABD UG POWER, NIC | |
| (43) PSE TO RMV TRANSF, NIC. | |
| (44) PSE TO ABD ELEC VLT/ JB, NIC. | |
| (45) PSE TO ABD ELEC SVC, NIC | |
| (49) CONTRACTOR TO RMV ABD FACILITY W/ EXC LIMITS. | |

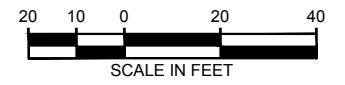

60% SUBMITTAL

DESIGNED BY:
B. NELSON
 DRAWN BY:
D. FRANKUM
 CHECKED BY:
J. WEBER
 APPROVED BY:
J. SCHUTT



The VOSK Group LLP
 Project and Construction Management Consultants
 SUBMITTED BY: DATE: REVIEWED BY: DATE:



SCALE:
1" = 20'
 FILENAME:
E335-L86-UCP101
 CONTRACT No.:
RTA/LR XXXX-XX
 DATE: 12/20/2013

**EAST LINK EXTENSION
 CONTRACT E335**
 DOWNTOWN BELLEVUE TO SPRING DISTRICT
 COMPOSITE UTILITY
 PLAN
 EB STA 536+00 TO EB STA 540+00

DRAWING No.:
L86-UCP101
 LOCATION ID:
 SHEET No.: REV:
0

- XREF LIST:**
- XE330-E15-SFP400
 - XE335-E19-APP100
 - XE335-E19-SFP100
 - XE335-E19-SGP100
 - XE335-L86-CAP100
 - XE335-L86-CMP100
 - XE335-L86-KAP100
 - XE335-L86-LPP100
 - XE335-L86-SFP100
 - XE335-L86-UCP100
 - XE335-L86-CDP100
 - XEL-0228x
 - XEL-0228f
 - XEL-0228t
 - XEL-0528x
 - XEL-0528f
 - XEL-0528t
 - XE335-GB-TB22x34
 - XE335-L86-RPP100
 - XE335-L86-CRP100
 - XE330-T86-STP001
 - XE330-T86-STP002
 - XE335-T86-STP003
 - GB-SEAL-SAK37898
 - XE320-L85-CAP100
 - XE335-L86-CLP100
 - XE335-L86-SFP100
 - XE335-L86-EFP300
 - XE335-L86-JEP100
 - XE335-L86-JOP100
 - XE335-L86-SWP100
 - XE335-L86-TSP100

ORIGINATED BY: / DATE: /
 CHECKED BY: / DATE: /
 BACK-CHECKED BY: / DATE: /
 C:\USERS\PUBLIC\DOCUMENTS\FRANKUM\DRAWINGS\E335-L86-UCP102.DWG

CORRECTED BY: / DATE: /
 VERIFIED BY: / DATE: /

SEE DWG L86-UCP101

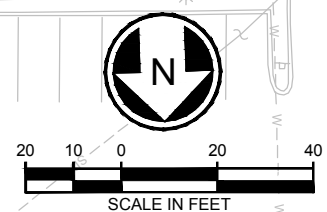
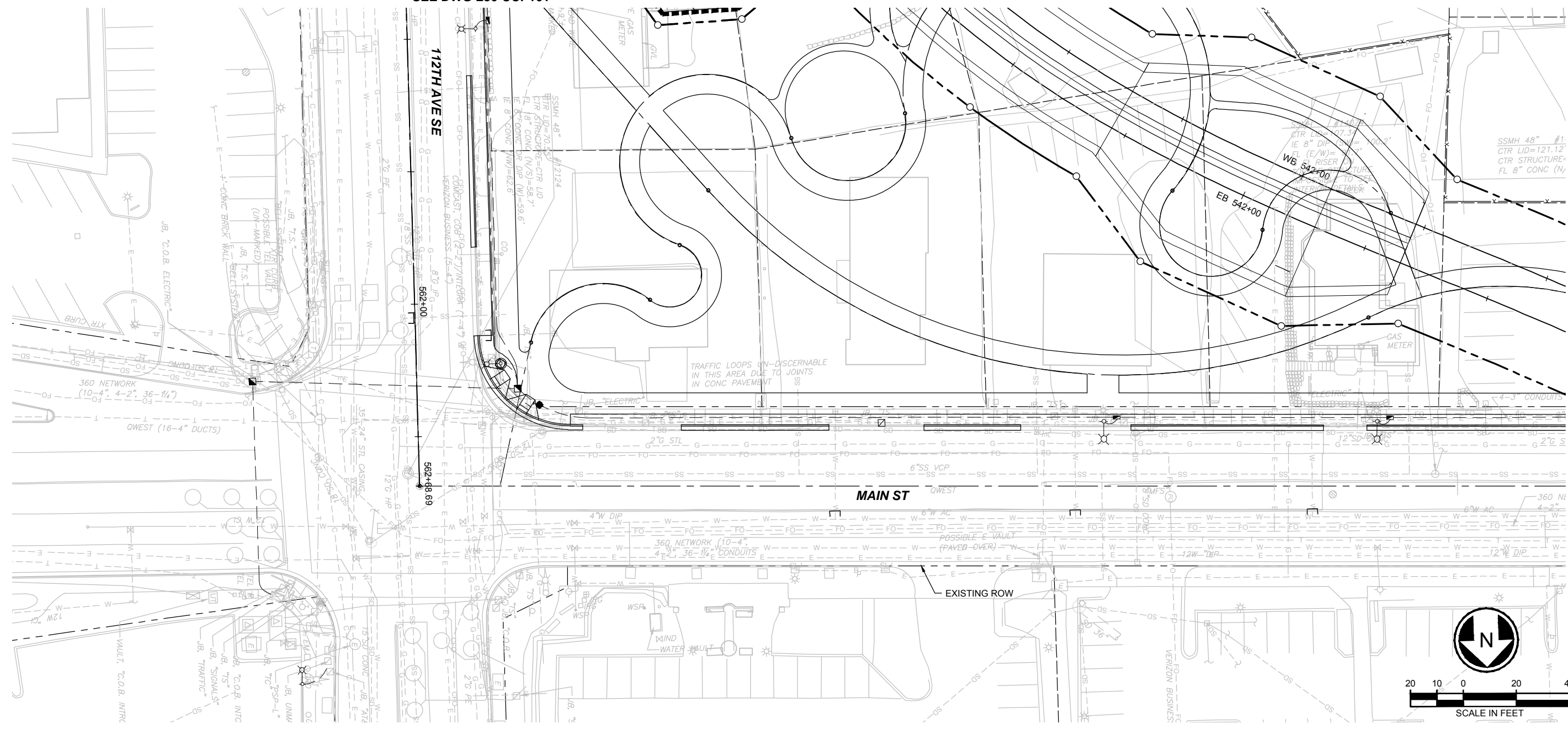

SEE DWG L86-UCP103

60% SUBMITTAL

DESIGNED BY:	S. KIRBY
DRAWN BY:	D. FRANKUM
CHECKED BY:	J. WEBER
APPROVED BY:	J.SCHUTT

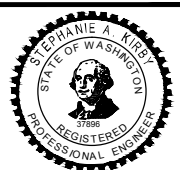

The **VOSK** Group LLP
 Project and Construction Management Consultants

H J H
 FINAL DESIGN PARTNERS.

LINE IS 1" AT FULL SCALE

SOUNDTRANSIT

SCALE: 1" = 20'
 FILENAME: E335-L86-UCP102
 CONTRACT No.: RTA/LR XXXX-XX
 DATE: 12/20/2013

**EAST LINK EXTENSION
 CONTRACT E335**
 DOWNTOWN BELLEVUE TO SPRING DISTRICT
 COMPOSITE UTILITY
 PLAN
 EB STA 540+00 TO EB STA 543+00

DRAWING No.:	L86-UCP102
LOCATION ID:	
SHEET No.:	REV: 0

No.	DATE	DSN	CHK	APP	REVISION

- XREF LIST:**
- XE330-E15-SFP400
 - XE335-E19-APP100
 - XE335-E19-SFP100
 - XE335-E19-SGP100
 - XE335-L86-CAP100
 - XE335-L86-CMP100
 - XE330-L86-CSP100
 - XE335-L86-LPP100
 - XE335-L86-SFP100
 - XE335-L86-CDP100
 - XEL-0228x
 - XEL-0228f
 - XEL-0228t
 - XEL-0528x
 - XEL-0528f
 - XEL-0528t
 - XE335-CB-1B22x34
 - XE335-L86-RPP100
 - XE335-L86-CRP100
 - XE330-L86-STP001
 - XE330-L86-STP002
 - XE335-L86-STP003
 - XE335-L86-UCP100
 - CB-SEAL-SAK37898
 - XE335-L86-KAP100
 - XE335-L86-EPP100
 - XE335-L86-EPP300
 - XE335-L86-CLP100
 - XE335-L86-JEP100
 - XE335-L86-JOP100
 - XE335-L86-SWP100
 - XE335-L86-TSP100

ORIGINATED BY: / DATE: /
 CORRECTED BY: / DATE: /
 VERIFIED BY: / DATE: /
 BACK-CHECKED BY: / DATE: /
 FRANKUM /
 11:38 AM /
 C:\USERS\PUBLIC\DOCUMENTS\FRANKUM\DRAWINGS\E335-L86-UCP103.DWG



NOTES:
 1. SEE LANDSCAPE DRAWINGS FOR CONTINUATION.

CONSTRUCTION NOTES:
 (88) CONNECT TO EXIST WM.
 (107) CONST 2" IRRIG WATER SVC PER COB STD PLAN W-31.

SEE DWG L86-UCP104

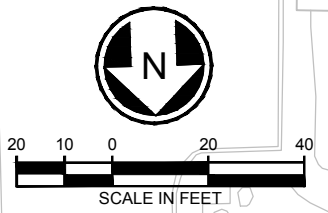

60% SUBMITTAL

DESIGNED BY:
S. KIRBY
 DRAWN BY:
D. FRANKUM
 CHECKED BY:
J. WEBER
 APPROVED BY:
J. SCHUTT



The VOSK Group LLP
 Project and Construction Management Consultants



SCALE:
1" = 20'
 FILENAME:
E335-L86-UCP103
 CONTRACT No.:
RTA/LR XXXX-XX
 DATE:
12/20/2013

**EAST LINK EXTENSION
 CONTRACT E335**
 DOWNTOWN BELLEVUE TO SPRING DISTRICT
 COMPOSITE UTILITY
 PLAN
 EB STA 543+00 TO EB STA 546+00

DRAWING No.:
L86-UCP103
 LOCATION ID:
 SHEET No.: REV:
 0

XREF LIST:
 XE335-L86-CAP100
 XE335-L86-CMP100
 XE335-L86-LPP100
 XE335-L86-SFP100
 XE335-L86-UCP100
 XE335-L86-CDP100
 XEL-0228x
 XEL-0228f
 XEL-0228t
 XEL-0528x
 XEL-0528f
 XEL-0528t
 XE335-09-TR22x34
 XE335-L86-RPP100
 XE335-L86-CRP100
 XE335-L86-STP001
 XE335-L86-STP003
 GB-SEAL-SAK37896
 XE335-L86-KAP100
 XE335-L86-CLP100
 XE335-L86-EPP100
 XE335-L86-EPP300
 XE335-L86-JEP100
 XE335-L86-JCP100
 XE335-L86-SWP100
 XE335-L86-TSP100

ORIGINATED BY: / DATE: /
 CHECKED BY: / DATE: /
 BACK-CHECKED BY: / DATE: /
 12/18/13 | 2:36 PM | SCHWANTESG
 C:\USERS\PUBLIC\DOCUMENTS\SCHWANTESG\SHARPOINT\SOUND TRANSIT\ORG\443\SITES\CAD\BELLEVUE\DRAWINGS\E335-L86-UCP104.DWG

SEE DWG L86-UCP103

SEE DWG L86-UCP105

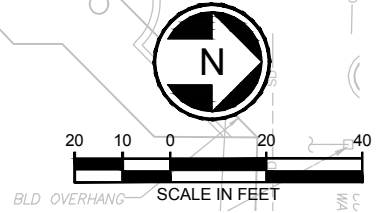
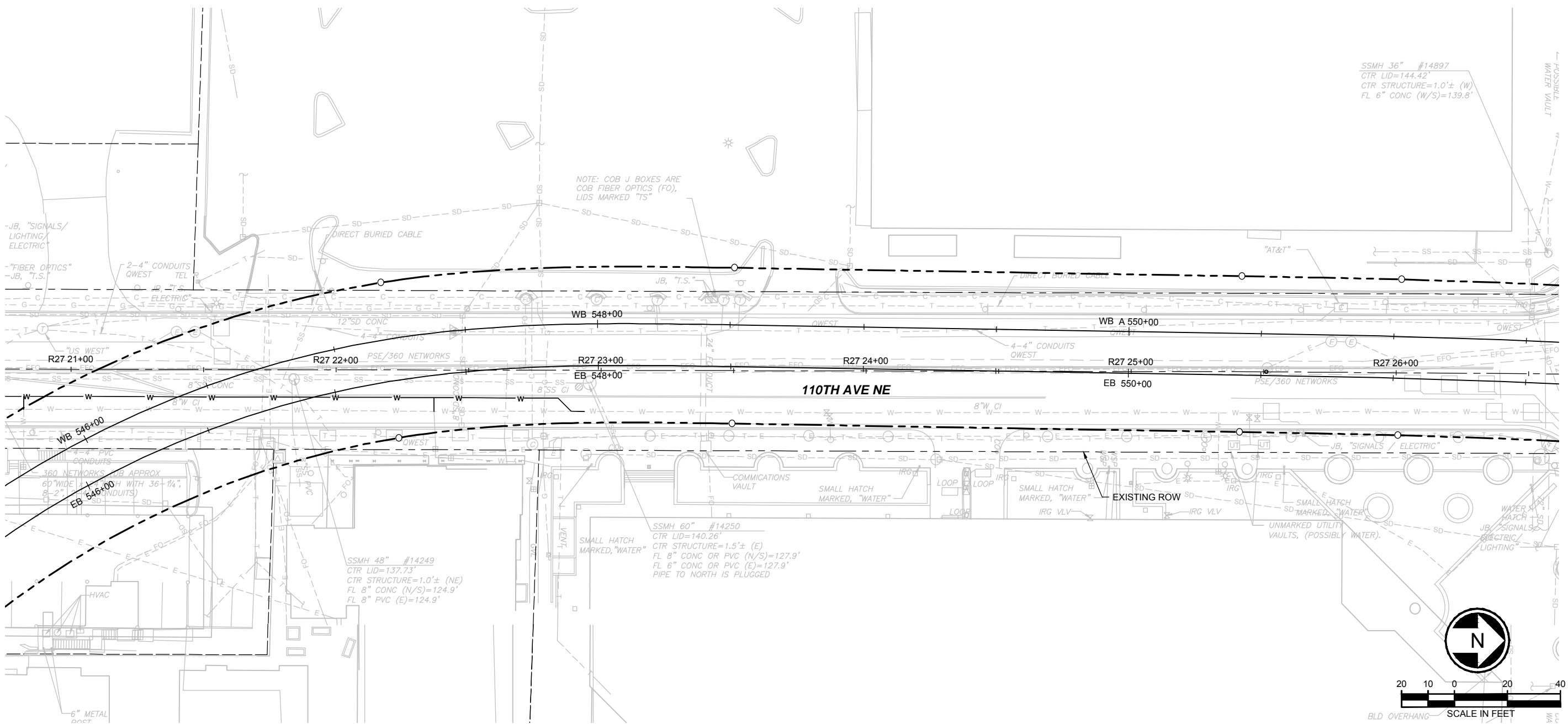

60% SUBMITTAL

DESIGNED BY:
S. KIRBY
 DRAWN BY:
D. FRANKUM
 CHECKED BY:
J. WEBER
 APPROVED BY:
J. SCHUTT



The VOSK Group LLP
 Project and Construction Management Consultants



SCALE:
1" = 20'
 FILENAME:
E335-L86-UCP104
 CONTRACT No.:
RTA/LR XXXX-XX
 DATE:
12/20/2013

EAST LINK EXTENSION
 CONTRACT E335
 DOWNTOWN BELLEVUE TO SPRING DISTRICT
 COMPOSITE UTILITY
 PLAN
 EB STA 546+00 TO EB STA 551+50

DRAWING No.:
L86-UCP104
 LOCATION ID:
 SHEET No.: REV:
0

- XREF LIST:**
- XE330-E15-SFP400
 - XE335-E19-APP100
 - XE335-E19-SFP100
 - XE335-E19-SGP100
 - XE335-L86-CAP100
 - XE335-L86-CMP100
 - XE335-L86-LPP100
 - XE335-L86-SFP100
 - XE335-L86-UCP100
 - XE335-L86-CDP100
 - XEL-0228rx
 - XEL-0228sf
 - XEL-0228bt
 - XEL-0528rx
 - XEL-0528sf
 - XEL-0528bt
 - XE335-GB-TB22x34
 - XE335-L86-RPP100
 - XE330-T86-STP001
 - XE330-T86-STP002
 - XE335-T86-STP003
 - GB-SEAL-SAK37896
 - XE335-L86-CLP100
 - XE335-L86-CRP100
 - XE335-L86-EPP100
 - XE335-L86-EPF100
 - XE335-L86-JOP100
 - XE335-L86-SWP100
 - XE335-L86-TSP100
 - XE335-L86-KAP100

ORIGINATED BY: / DATE: /
 CHECKED BY: / DATE: /
 CORRECTED BY: / DATE: /
 VERIFIED BY: / DATE: /
 12/04/13 | 12:28 PM | FRANKUM
 C:\USERS\PUBLIC\DOCUMENTS\FRANKUM\DRAWING\PROJECTS\E335\DRAWINGS\E335-L86-UCP105.DWG

SEE DWG L86-UCP104

SEE DWG L86-UCP106

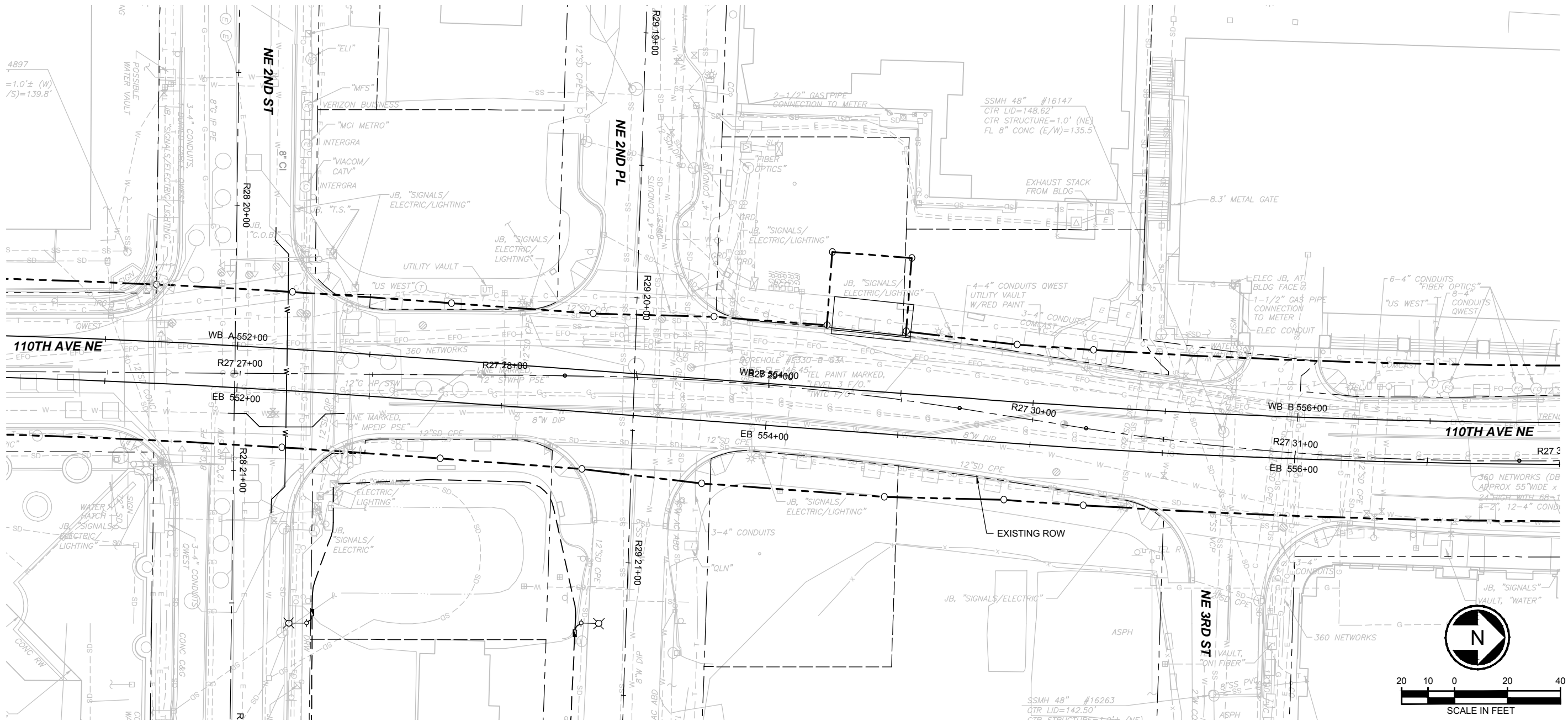

SEE DWG L86-UCP142

60% SUBMITTAL

DESIGNED BY:
S. KIRBY
 DRAWN BY:
D. FRANKUM
 CHECKED BY:
J. WEBER
 APPROVED BY:
J. SCHUTT



The VOSK Group LLP
 Project and Construction Management Consultants



LINE IS 1" AT FULL SCALE



SCALE:
1" = 20'
 FILENAME:
E335-L86-UCP105
 CONTRACT No.:
RTA/LR XXXX-XX
 DATE:
12/20/2013

**EAST LINK EXTENSION
 CONTRACT E335**
 DOWNTOWN BELLEVUE TO SPRING DISTRICT
 COMPOSITE UTILITY
 PLAN
 EB STA 551+50 TO EB STA 557+00

DRAWING No.:
L86-UCP105
 LOCATION ID:
 SHEET No.: REV:
0

- XREF LIST:**
- XE335-L86-CAP100
 - XE335-L86-CMP100
 - XE335-L86-KAP100
 - XE335-L86-LPP100
 - XE335-L86-SFP100
 - XE335-L86-CDP100
 - XEL-0228R
 - XEL-0228F
 - XEL-0228M
 - XEL-0228S
 - XEL-0528F
 - XEL-0528M
 - XEL-0528S
 - XE335-09-TB22x34
 - XE335-L86-RPP100
 - XE335-L86-CRP100
 - XE335-L86-UCP100
 - XE335-L86-STP001
 - XE335-L86-STP003
 - GB-SEAL-SAK37896
 - XE335-L86-CLP100
 - XE335-L86-EPP100
 - XE335-L86-EP100
 - XE335-L86-OP100
 - XE335-L86-SWP100
 - XE335-L86-TSP100

ORIGINATED BY: / DATE: /
 CHECKED BY: / DATE: /
 BACK-CHECKED BY: / DATE: /
 CORRECTED BY: / DATE: /
 VERIFIED BY: / DATE: /
 C:\USERS\PUBLIC\DOCUMENTS\SCHWANTESG\SHARPOINT\SOUND TRANSIT\ORG\443\SITES\CAD\BELREDE\E335-L86-UCP106.DWG

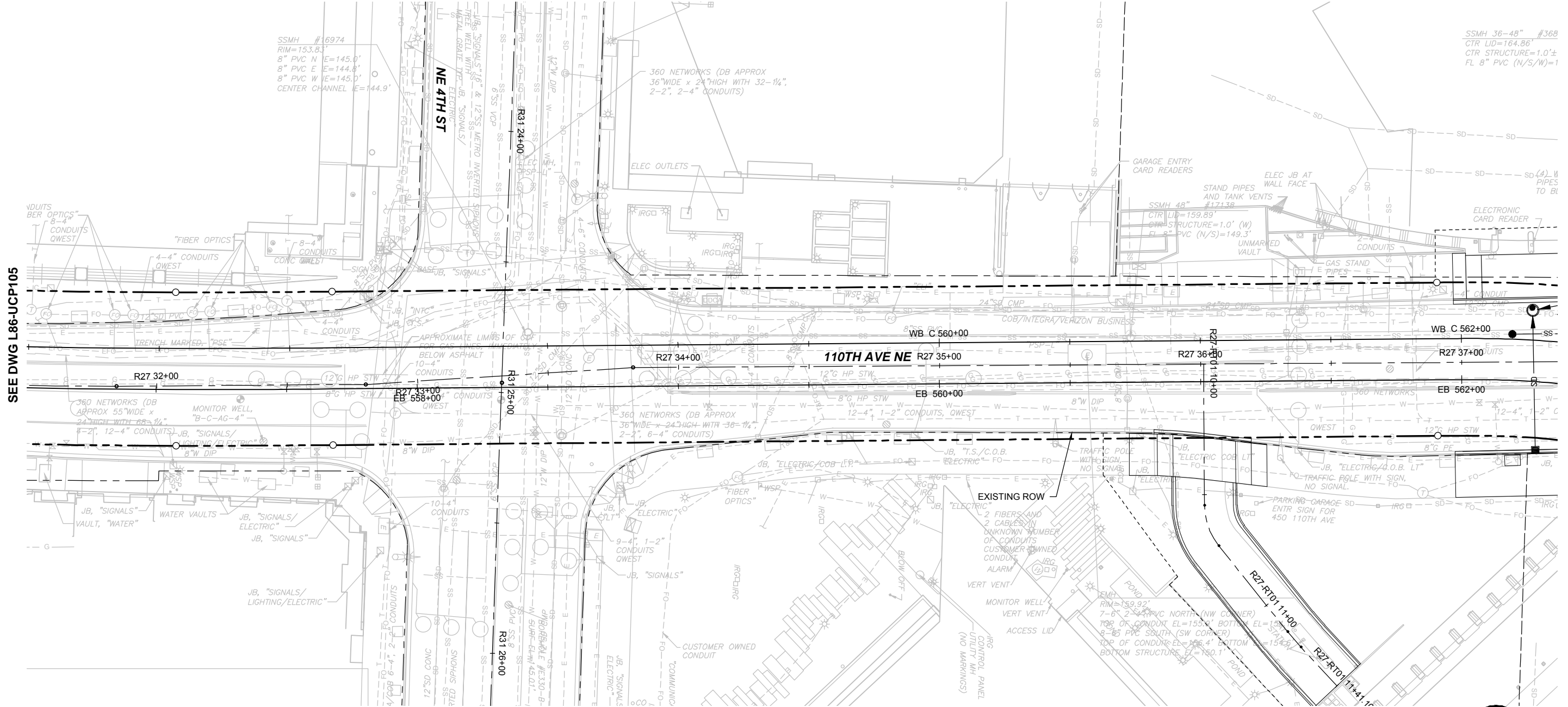

SEE DWG L86-UCP105

SEE DWG L86-UCP107

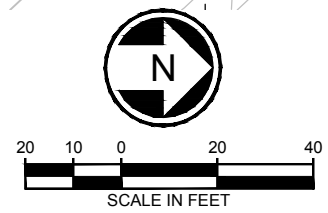

60% SUBMITTAL

DESIGNED BY:
S. KIRBY
 DRAWN BY:
D. FRANKUM
 CHECKED BY:
J. WEBER
 APPROVED BY:
J. SCHUTT



The VOSK Group LLP
 Project and Construction Management Consultants



SCALE:
1" = 20'
 FILENAME:
E335-L86-UCP106
 CONTRACT No.:
RTA/LR XXXX-XX
 DATE:
12/20/2013

**EAST LINK EXTENSION
 CONTRACT E335**
 DOWNTOWN BELLEVUE TO SPRING DISTRICT
 COMPOSITE UTILITY
 PLAN
 EB STA 557+00 TO EB STA 562+00

DRAWING No.:
L86-UCP106
 LOCATION ID:
SHEET No.: REV:
0

- XREF LIST:**
- XE330-E15-SFP400
 - XE335-E19-APP100
 - XE330-L86-CSP100
 - XE335-L86-LPP100
 - XE335-L86-UCP100
 - XE335-L86-CDP100
 - XEL-0228R
 - XEL-0228F
 - XEL-0228B
 - XEL-0228S
 - XE335-GB-T822X4
 - XE335-L86-RFP100
 - XE335-L86-CP100
 - XE335-L86-CAP100
 - XE330-L86-STP001
 - CB-SEAL-SAC37896
 - XEL-0228B
 - XE335-L86-STP003
 - XE335-L86-TSP100
 - XE335-L86-CLP100
 - XE335-L86-EPP100
 - XE335-L86-EP100
 - XE335-L86-JOP100
 - XE335-L86-SWP100
 - XE335-L86-SVP100
 - XE335-L86-KAP100

ORIGINATED BY: / DATE: /
 CHECKED BY: / DATE: /
 BACK-CHECKED BY: / DATE: /
 C:\USERS\PUBLIC\DOCUMENTS\FRANKUM\DWG\TRANSIT\ORG44\SITES\CAD\BEL\RED\E335\DRAWINGS\E335-L86-UCP107.DWG

CORRECTED BY: / DATE: /
 VERIFIED BY: / DATE: /

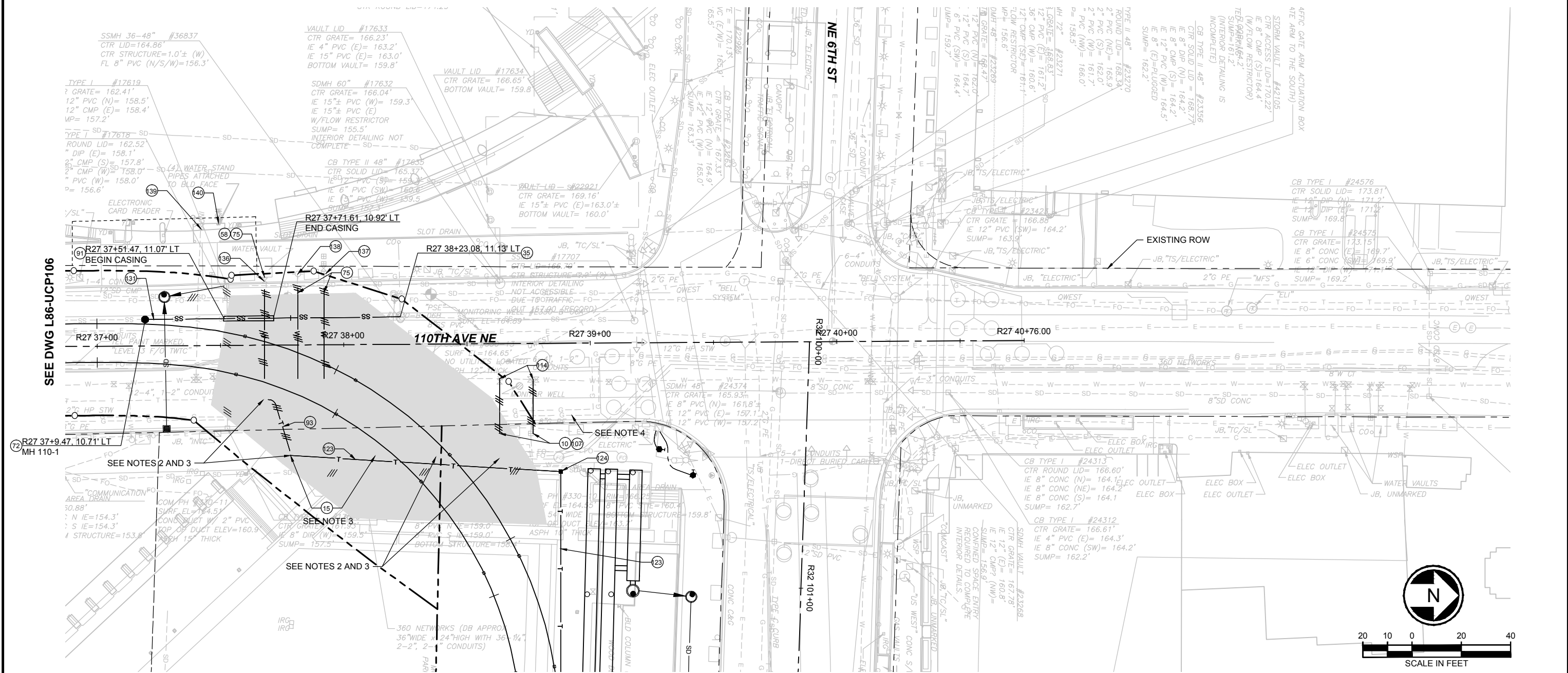

SEE DWG L86-UCP106

SEE DWG L86-UCP108

NOTES:

- SEE NOTES UZN001 FOR DISCONNECTION / ABANDONMENT / REMOVAL OF UTILITY SERVICES AT BUILDING TO BE DEMOLISHED.
- TELECOMM TO DEMOLISH VAULT AND PREPARE F.O. FOR SUPPORT.
- NEW VAULTS TO BE PLACED BY UTILITY PRIOR TO RECONSTRUCTION OF STREET AND SIDEWALK.
- PSE TO SHUT OFF 12" HP GAS MAIN PRIOR TO START OF CONSTRUCTION.

CONSTRUCTION NOTES:

- 10 RMV EXIST METER BOX
- 15 RMV COMM VAULT
- 35 CONNECT TO EXIST MH
- 55 CONST CASING PER COB STD PLAN W-7.
- 58 CONST 8" DI WATER MAIN.
- 72 CONST STD MH PER COB STD PLAN S-1.
- 75 RECON EXIST WATER SVC.
- 91 CONST CASING PER COB STD PLAN SS-33.
- 93 UTIL TO CONST UG TELECOMM, NIC.
- 107 CONST 2" IRRIG WATER SVC PER COB STD PLAN W-31.
- 114 COORD W/COB TO SHUT OFF VALVE DURING CONSTRUCTION.
- 123 CONST 2" PVC CONDUIT (STATION PROVISIONS FOR PUBLIC PHONE SERVICE)
- 124 CONST TELECOM VLT/JB
- 131 CONST 8" DI SS
- 136 REPLACE EXIST 4" DOM SVC
- 137 REPLACE EXIST 2" IRRIG LINE
- 138 REPLACE EXIST 8" FH LINE
- 139 EXIST 8" FIRE SVC
- 140 EXIST 2" IRRIG SVC

LEGEND:

SUPPORT UTILITIES FROM TEMP DECKING WITHIN LIMITS OF CUT AND COVER TUNNEL. SEE STRUCTURAL DRAWINGS FOR TEMPORARY SUPPORT DETAILS.

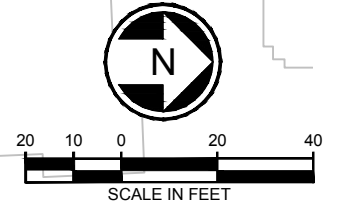

60% SUBMITTAL

DESIGNED BY:
S. KIRBY
DRAWN BY:
D. FRANKUM
CHECKED BY:
J. WEBER
APPROVED BY:
J. SCHUTT



The **VOSK** Group LLP
Project and Construction Management Consultants



LINE IS 1" AT FULL SCALE



SCALE:
1" = 20'
FILENAME:
E335-L86-UCP107
CONTRACT No.:
RTA/LR XXXX-XX
DATE:
12/20/2013

**EAST LINK EXTENSION
CONTRACT E335**
DOWNTOWN BELLEVUE TO SPRING DISTRICT
**COMPOSITE UTILITY
PLAN**
EB STA 562+00 TO EB STA 564+00

DRAWING No.:
L86-UCP107
LOCATION ID:
SHEET No.:
REV:
0

XREF LIST:
 XE335-L86-CMP100
 XE335-L86-CAP100
 XE335-L86-LPP100
 XE335-L86-SFP100
 XE335-L86-CDP100
 XEL-0228R
 XEL-0228F
 XEL-0528R
 XEL-0528F
 XE335-GB-TB22X4
 XE335-E15-APP200
 XE335-L86-RPP100
 XE335-L86-CRP100
 XE335-E15-APP100
 XE335-L86-CAP100
 GB-SEAL-SAK37896
 XE335-L86-UCP100
 XE335-L86-LRP100
 XE335-L86-CLP100
 XE335-E15-EPP100
 XE335-L86-EPP300
 XE335-L86-EPP100
 XE335-L86-EPP300
 XE335-L86-JEP100
 XE335-L86-JEP100
 XE335-L86-SWP100
 XE335-L86-TSP100

1H VAULT #2326B
 GRADE = 167.78'
 12" (E) = 160.8'
 12" CMP? (NW) =
 IP = 156.9'
 FINED SPACE ENTRY
 WIRED TO COMPLETE
 PRIOR DETAILS.

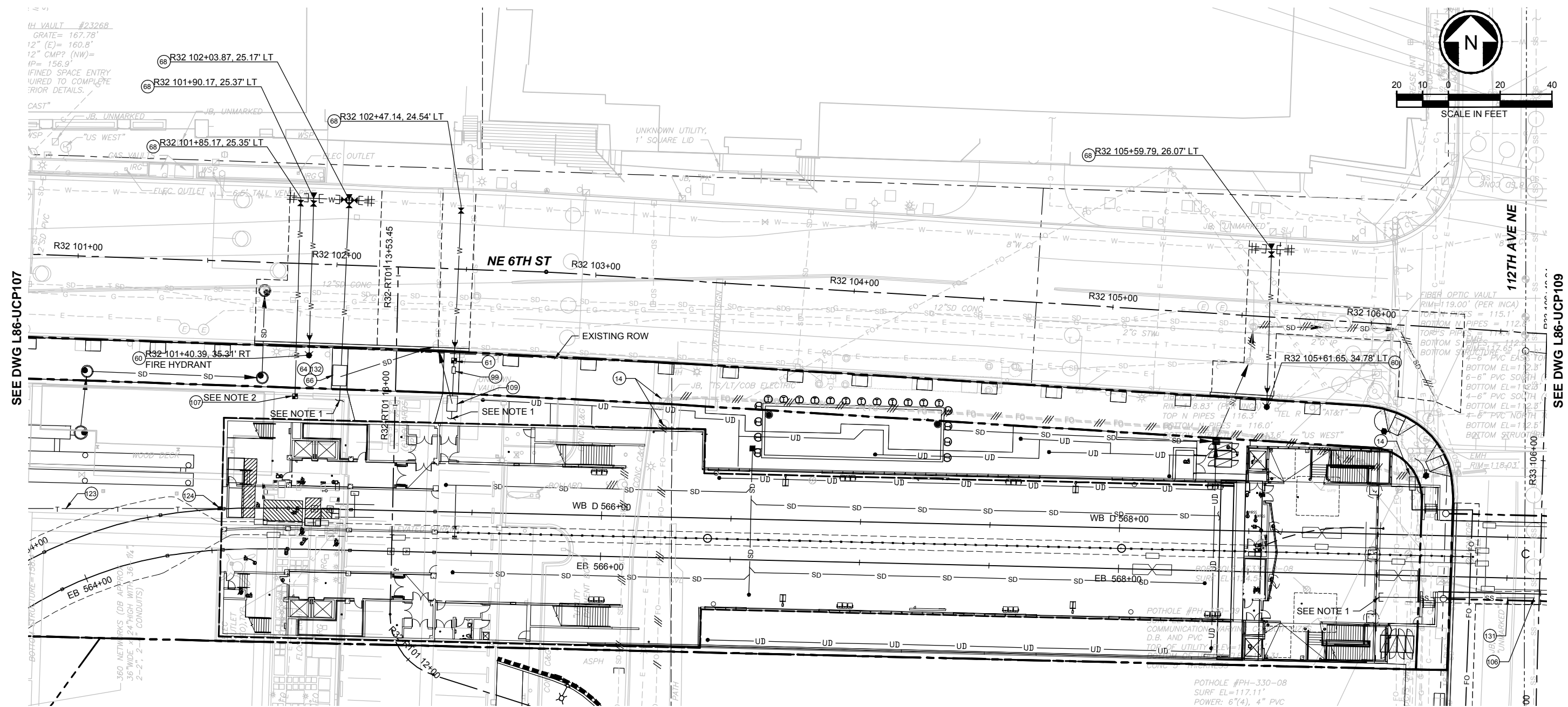
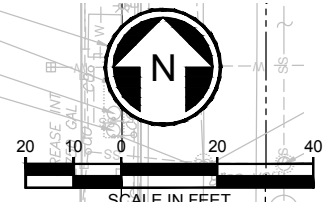

SEE DWG L86-UCP107

SEE DWG L86-UCP109

SEE DWG L86-UCP143

- NOTES:**
- SEE BELLEVUE TRANSIT CENTER STATION MECHANICAL DRAWINGS FOR CONTINUATION.
 - SEE BELLEVUE TRANSIT CENTER STATION LANDSCAPE DRAWINGS FOR CONTINUATION.

- CONSTRUCTION NOTES:**
- 14 RMV JUNCTION BOX
 - 60 CONST HYD PER COB STD PLAN W-13.
 - 61 CONST 1.5" DOM WATER SVC PER COB STD PLAN W-26
 - 64 CONST DI FIRE SVC PER COB STD PLAN W-40.
 - 66 CONST DCVA PER COB STD PLAN W-45.
 - 68 CONNECT TO EXIST WM.
 - 69 CONST PRV PER COB STD PLAN W-21.
 - 106 CONN TO EXIST SS MAIN.
 - 107 CONST 2" IRRIG WATER SVC PER COB STD PLAN W-31.
 - 109 CONST DCVA PER COB STD PLAN W-41.
 - 123 CONST 2" PVC CONDUIT (STATION PROVISIONS FOR PUBLIC PHONE SERVICE)
 - 124 CONST TELECOM VLT/JB
 - 131 CONST 8" DI SS
 - 132 CONST DI 8" FIRE SVC.

ORIGINATED BY: / DATE: /
 CHECKED BY: / DATE: /
 BACK-CHECKED BY: / DATE: /
 12/18/13 | 2:49 PM | SCHWANTESG
 C:\USERS\PUBLIC\DOCUMENTS\SCHWANTESG\SCHWANTESG\SHAREPOINT\SOUND TRANSIT\ORG\443\SITES\CAD\BELLEVUE\DRAWINGS\E335-L86-UCP108.DWG

60% SUBMITTAL

DESIGNED BY:
S. KIRBY
 DRAWN BY:
D. FRANKUM
 CHECKED BY:
J. WEBER
 APPROVED BY:
J. SCHUTT



The VOSK Group LLP
 Project and Construction Management Consultants

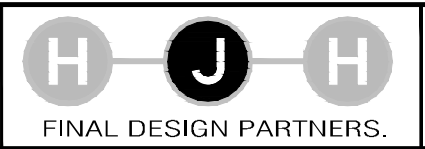

SCALE:
1" = 20'
 FILENAME:
E335-L86-UCP108
 CONTRACT No.:
RTA/LR XXXX-XX
 DATE:
12/20/2013

**EAST LINK EXTENSION
 CONTRACT E335**
 DOWNTOWN BELLEVUE TO SPRING DISTRICT
 COMPOSITE UTILITY
 PLAN
 EB STA 564+00 TO EB STA 570+00

DRAWING No.:
L86-UCP108
 LOCATION ID:
 SHEET No.: REV:
0

- XREF LIST:**
- XE330-E15-SFP400
 - XE335-E19-APP100
 - XE335-E19-SFP100
 - XE335-E19-SGP100
 - XE335-L86-CMP100
 - XE335-L86-CSP100
 - XE335-L86-KAP100
 - XE335-L86-LPP100
 - XE335-L86-SFP100
 - XE335-L86-SWP100
 - XL-0528x
 - XL-0528f
 - XL-0528t
 - XE335-GB-TB22x34
 - XE335-L86-RPP100
 - XE335-L86-CRP100
 - XE335-L86-CAP100
 - GB-SEAL-SAK37866
 - XE335-L86-UCP100
 - XE335-L86-CLP100
 - XE335-L86-EPP100
 - XE335-L86-EPP300
 - XE335-L86-JEP100
 - XE335-L86-JCP100
 - XE335-L86-SWP100
 - XE335-L86-TSP100

ORIGINATED BY: / DATE: /
 CHECKED BY: / DATE: /
 CORRECTED BY: / DATE: /
 VERIFIED BY: / DATE: /
 BACK-CHECKED BY: / DATE: /
 11/19/13 | 1:18 PM | FRANKUMD
 C:\USERS\PUBLIC\DOCUMENTS\FRANKUMD\PROJECTS\SHARPPOINT\SOUNDTRANSIT\ORG44\SITES\CAD\BEL\RED\E335\DRAWINGS\E335-L86-UCP109.DWG

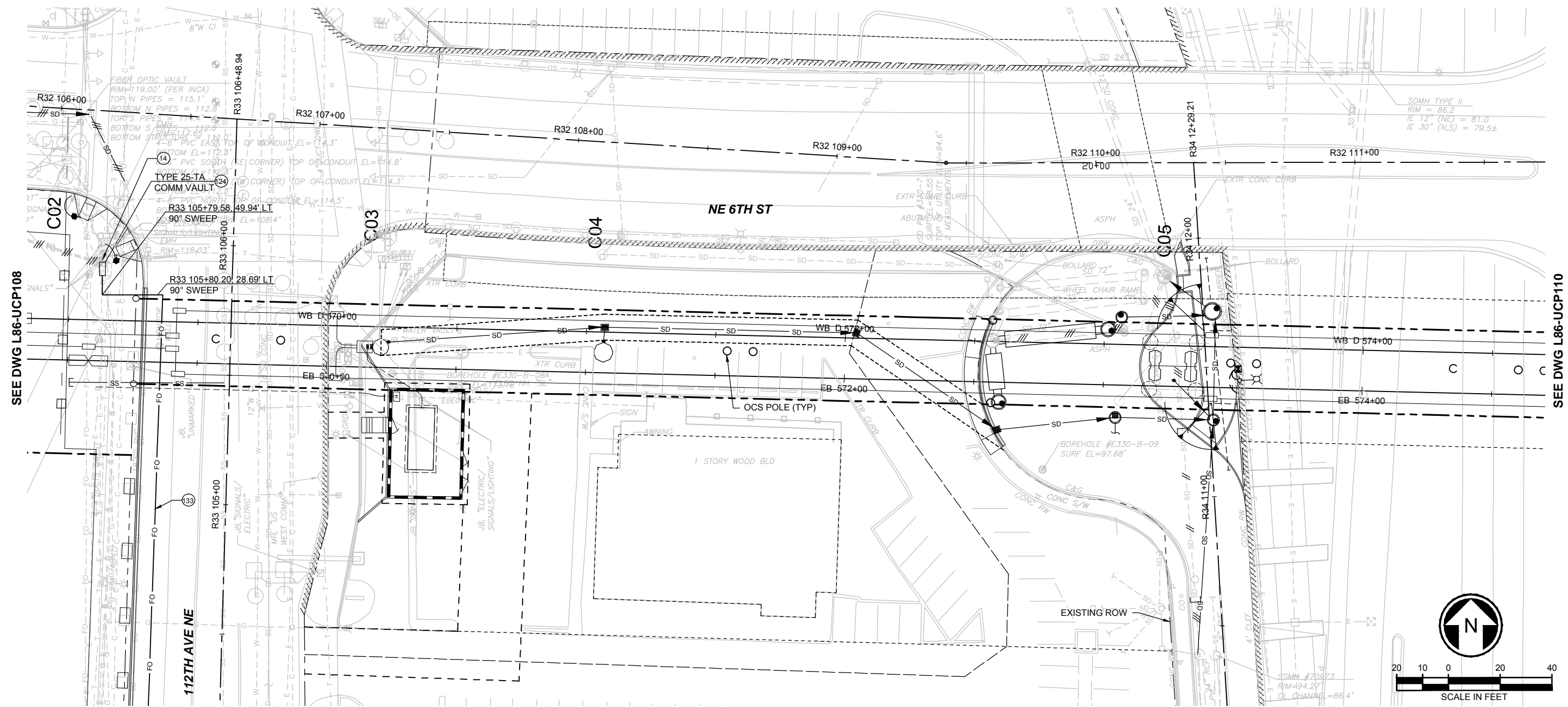

SEE DWG L86-UCP108

SEE DWG L86-UCP143

SEE DWG L86-UCP110

- CONSTRUCTION NOTES:**
- (14) RMV JUNCTION BOX
 - (124) CONST TELECOM VLT/JB
 - (133) CONST 2.4" PVC CONDUIT (FOR COB FO)

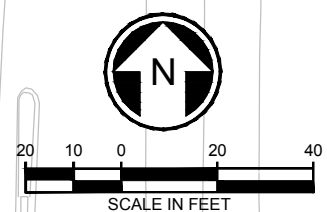

60% SUBMITTAL

DESIGNED BY:
S. KIRBY
 DRAWN BY:
D. FRANKUM
 CHECKED BY:
J. WEBER
 APPROVED BY:
J. SCHUTT



The **VOSK** Group, LLP
 Project and Construction Management Consultants

H J H
FINAL DESIGN PARTNERS.
 LINE IS 1" AT FULL SCALE

SOUNDTRANSIT
 SCALE: 1" = 20'
 FILENAME: E335-L86-UCP109
 CONTRACT No.: RTA/LR XXXX-XX
 DATE: 12/20/2013

EAST LINK EXTENSION CONTRACT E335
 DOWNTOWN BELLEVUE TO SPRING DISTRICT
 COMPOSITE UTILITY PLAN
 EB STA 570+00 TO EB STA 575+00

DRAWING No.: **L86-UCP109**
 LOCATION ID:
 SHEET No.: REV: **0**

XREF LIST:
 XE335-L86-CAP100
 XE335-L86-CMP100
 XE335-L86-LPP100
 XE335-L86-SFP100
 XE335-L86-UCP100
 XE335-L86-CDP100
 XEL-0528x
 XEL-0528f
 XEL-0528t
 XE335-C8-TB22x34
 XE335-L86-RPP100
 XE335-L86-KAP100
 CB-SEAL-SAK37886
 XE335-L86-CRP100
 XE335-L86-CLP100
 XE335-L86-TSP100
 XE335-L86-EPP100
 XE335-L86-EPP300
 XE335-L86-JEP100
 XE335-L86-JOP100
 XE335-L86-SWP100

ORIGINATED BY: / DATE: /
 CORRECTED BY: / DATE: /
 VERIFIED BY: / DATE: /
 11/19/13 1:21 PM | FRANKUM | D:\PROJECTS\BELL\REVISED\DRWING\ES335-L86-UCP110.DWG
 BACK-CHECKED BY: / DATE: /
 C:\USERS\PUBLIC\DOCUMENTS\FRANKUM\DRAWING\ES335-L86-UCP110.DWG

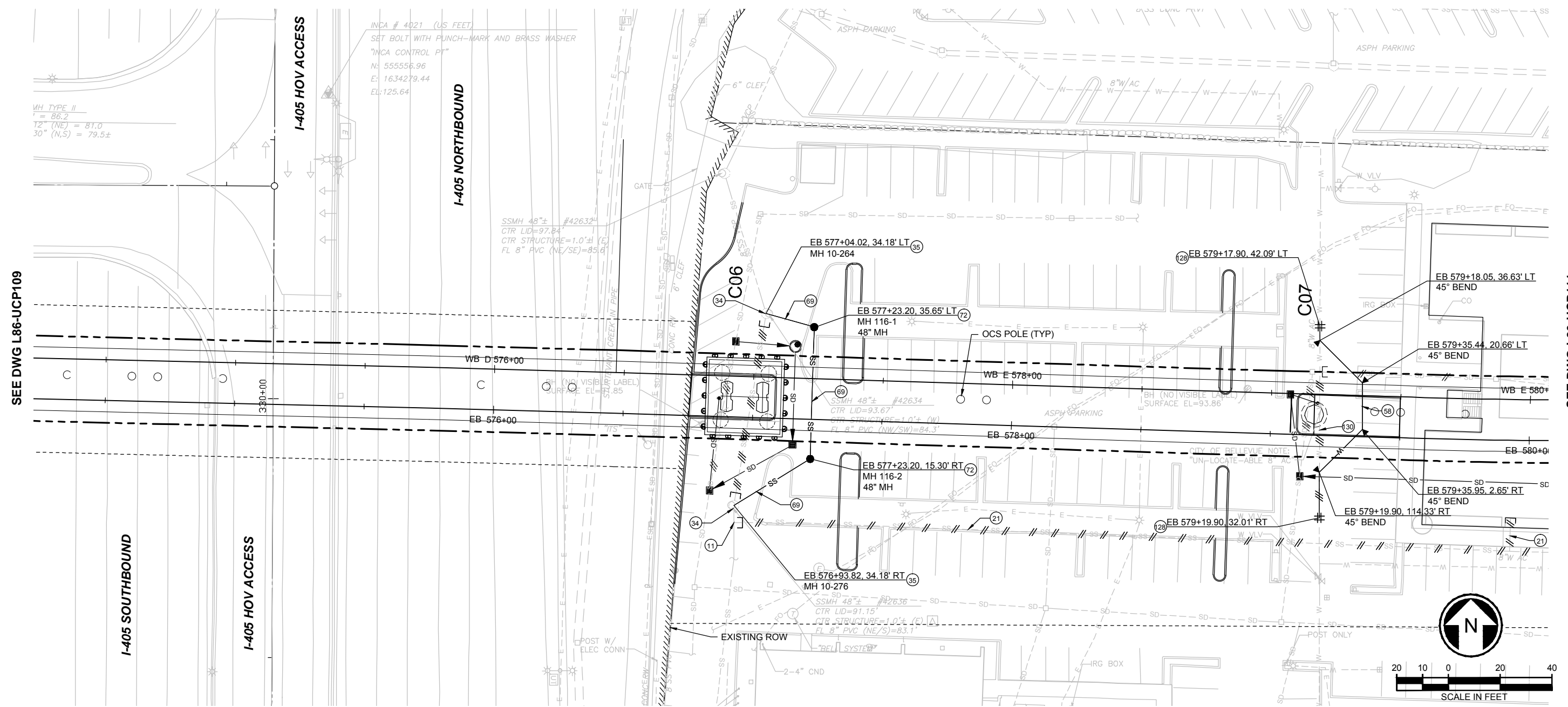

NOTES:
 1. SEE NOTES UZN001 FOR DISCONNECTION / ABANDONMENT / REMOVAL OF UTILITY SERVICES AT BUILDINGS TO BE DEMOLISHED.

- CONSTRUCTION NOTES:**
- (11) RMV SVC CONNECT AND REPAIR
 - (21) ABD SANITARY SIDE SEWER FILL W/CDF
 - (34) RECHANNEL EXIST MH
 - (35) CONNECT TO EXIST MH
 - (68) CONST 8" DI WATER MAIN.
 - (69) CONST 8" PVC SS MAIN.
 - (72) CONST STD MH PER COB STD PLAN S-1.
 - (28) CONST SPOT REPAIR CURED-IN-PLACE LINER PER COB SPEC S6-15
 - (28) CONNECT TO EXIST AC WM. COMPLY W/COB AC HANDLING REQUIREMENTS PER COB STD PLAN W-8.
 - (30) RMV EXIST AC PIPE. COMPLY W/COB AC HANDLING REQUIREMENTS PER COB STD PLAN W-8.

60% SUBMITTAL

DESIGNED BY:
S. KIRBY
 DRAWN BY:
D. FRANKUM
 CHECKED BY:
J. WEBER
 APPROVED BY:
J. SCHUTT



The VOSK Group LLP
 Project and Construction Management Consultants



SCALE:
1" = 20'
 FILENAME:
E335-L86-UCP110
 CONTRACT No.:
RTA/LR XXXX-XX
 DATE:
12/20/2013

**EAST LINK EXTENSION
 CONTRACT E335**
 DOWNTOWN BELLEVUE TO SPRING DISTRICT
 COMPOSITE UTILITY
 PLAN
 EB STA 575+00 TO EB STA 580+00

DRAWING No.:
L86-UCP110
 LOCATION ID:
 SHEET No.: REV:
0

XREF LIST:
 XE330-E15-SFP400
 XE335-E19-APP100
 XE335-E19-SFP100
 XE335-E19-SGP100
 XE335-L86-CAP100
 XE335-L86-CMP100
 XE335-L86-LPP100
 XE335-L86-SFP100
 XE335-L86-CDP100
 XE335-L86-CP100
 XE335-L86-EP100
 XE335-L86-EPP100
 XE335-L86-EPP300
 XE335-L86-JEP100
 XE335-L86-JOP100
 XE335-L86-SWP100
 XE335-L86-TSP100
 XE335-L86-UCP100

ORIGINATED BY: / DATE: /
 CHECKED BY: / DATE: /
 BACK-CHECKED BY: / DATE: /
 11/21/13 7:19 AM | FRANKUMD
 C:\USERS\PUBLIC\DOCUMENTS\FRANKUMD\PROJECTS\BELL BELLEVUE\DRWING\E335-L86-UCP111.DWG

CORRECTED BY: / DATE: /
 VERIFIED BY: / DATE: /

SEE DWG L86-UCP110

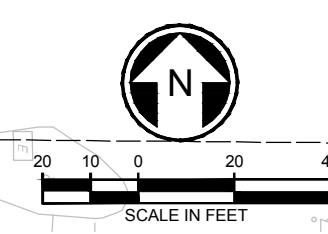
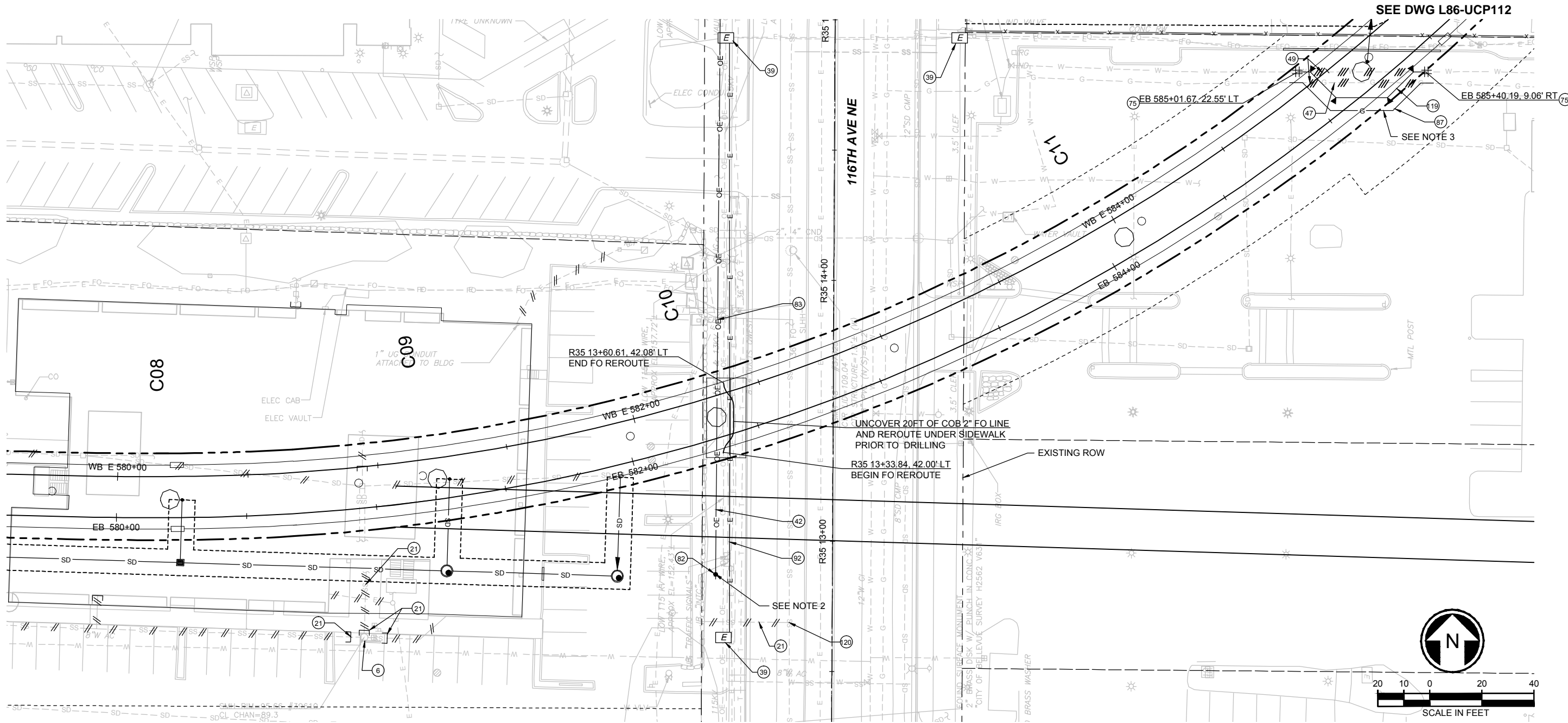

NOTES:

- SEE NOTES UZN001 FOR DISCONNECTION / ABANDONMENT / REMOVAL OF UTILITY SERVICES AT BUILDINGS TO BE DEMOLISHED.
- PSE TO RAISE ELEVATION OF 115KV OVERHEAD ELECTRIC PRIOR TO CONSTRUCTION OF AERIAL GUIDEWAY. SEE SPECIAL CONDITIONS FOR COORDINATION WITH PSE AND APPROVED CONSTRUCTION OUTAGES.
- GAS SERVICE TO BE PLACED WITH MIN 2 FT OF COVER, TO ALLOW UNDISTURBED SOIL FOR THRUST BLOCKS BELOW.

CONSTRUCTION NOTES:

- (6) PIP EXIST SSMH
- (21) ABD SANITARY SIDE SEWER FILL W/CDF
- (39) PSE TO CONST VLT/JB, NIC.
- (42) PSE TO RMV OH ELEC, NIC.
- (47) PSE TO ABD GAS SVC, NIC.
- (49) CONTRACTOR TO RMV ABD FACILITY W/I EXC LIMITS.
- (75) RECON EXIST WATER SVC.
- (82) PSE TO CONST PP, NIC.
- (83) PSE TO CONST OH ELEC, NIC.
- (87) PSE TO CONST GAS SVC, NIC.
- (92) PSE TO CONST UG POWER, NIC.
- (19) CONST 6" DI

60% SUBMITTAL

DESIGNED BY:
S. KIRBY
 DRAWN BY:
D. FRANKUM
 CHECKED BY:
J. WEBER
 APPROVED BY:
J. SCHUTT

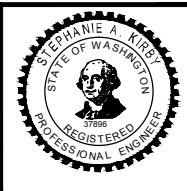

The VOSK Group LLP
 Project and Construction Management Consultants

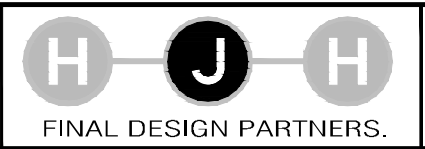

LINE IS 1" AT FULL SCALE



SCALE:
1" = 20'
 FILENAME:
E335-L86-UCP111
 CONTRACT No.:
RTA/LR XXXX-XX
 DATE:
12/20/2013

**EAST LINK EXTENSION
 CONTRACT E335**
 DOWNTOWN BELLEVUE TO SPRING DISTRICT
 COMPOSITE UTILITY
 PLAN
 EB STA 580+00 TO EB STA 585+00

DRAWING No.:
L86-UCP111
 LOCATION ID:
 SHEET No.: REV:
0

XREF LIST:
 XE335-L86-CAP100
 XE335-L86-CMP100
 XE335-L86-KAP100
 XE335-L86-LPP100
 XE335-L86-SFP100
 XE335-L86-UCP100
 XE335-L86-CDP100
 XE335-L86-APP100
 XE335-L86-TB22x34
 XE335-L86-CRP100
 XE335-L86-APP100
 XE335-L86-APP300
 XE335-L86-APP100
 XE335-L86-APP100
 XE335-L86-SWP100

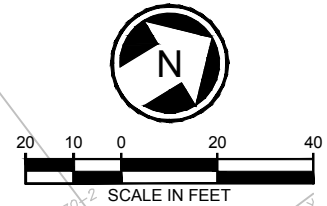

SEE DWG L86-UCP111

SEE DWG L86-UCP113

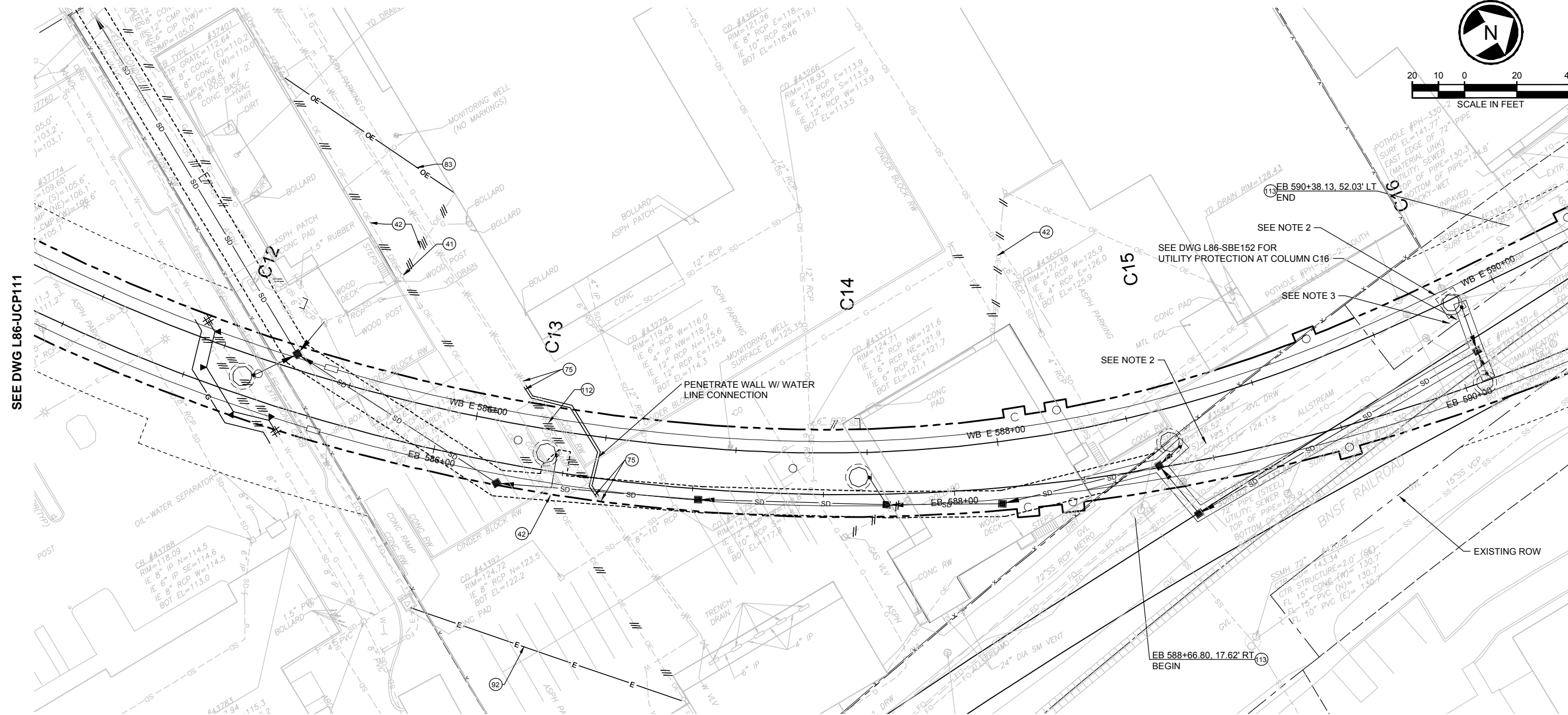

- NOTES:**
- SEE NOTES UZN001 FOR DISCONNECTION / ABANDONMENT / REMOVAL OF UTILITY SERVICES AT BUILDING TO BE DEMOLISHED.
 - STAKE EDGE OF KING COUNTY METRO 72" SEWER ALONG EDGE OF DRILLED SHAFT.
 - UNCOVER ALLSTREAM FIBER OPTIC LINE ADJACENT TO DRILLED SHAFT AND PROTECT WITH STEEL PLATING.

- CONSTRUCTION NOTES:**
- (41) PSE TO RMV PP, NIC.
 - (42) PSE TO RMV OH ELEC, NIC.
 - (75) RECON EXIST WATER SVC.
 - (83) PSE TO CONST OH ELEC, NIC.
 - (92) PSE TO CONST UG POWER, NIC.
 - (12) RELOC/RECONNECT 1" DOM WATER SVC.
 - (13) VIDEO INSP EXIST UTIL.

ORIGINATED BY: / DATE: /
 CORRECTED BY: / DATE: /
 CHECKED BY: / DATE: /
 BACK-CHECKED BY: / DATE: /
 VERIFIED BY: / DATE: /
 11/19/13 1:42 PM | FRANKUM | D
 C:\USERS\PUBLIC\DOCUMENTS\FRANKUM\DRAWINGS\E335-L86-UCP112.DWG

60% SUBMITTAL

DESIGNED BY:
S. KIRBY
 DRAWN BY:
D. FRANKUM
 CHECKED BY:
J. WEBER
 APPROVED BY:
J. SCHUTT



The VOSK Group LLP
 Project and Construction Management Consultants

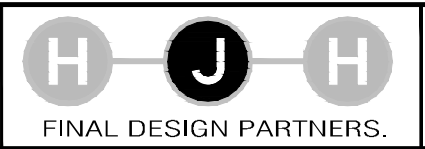

SCALE:
1" = 20'
 FILENAME:
E335-L86-UCP112
 CONTRACT No.:
RTA/LR XXXX-XX
 DATE:
12/20/2013

**EAST LINK EXTENSION
 CONTRACT E335**
 DOWNTOWN BELLEVUE TO SPRING DISTRICT
 COMPOSITE UTILITY
 PLAN
 EB STA 585+00 TO EB STA 590+00

DRAWING No.:
L86-UCP112
 LOCATION ID:
 SHEET No.: REV:
0



XREF LIST:
 XE335-E19-SGP100
 XE335-L86-CAP100
 XE335-L86-CMP100
 XE335-L86-CSP100
 XE335-L86-KAP100
 XE335-L86-LFP100
 XE335-L86-SFP100
 XE335-L86-CDP100
 XEL-0528x
 XEL-0528f
 XEL-0528t
 XEL-0531x
 XEL-0531f
 XEL-0531t
 XE335-L86-RPP100
 XE335-GB-1B22x24
 XE335-L86-CRP100
 XE335-E19-APP100
 XE335-E19-APP200
 GB-SEAL-SAK37896
 XE335-L86-UCP100
 XE335-L86-CLP100
 XE335-L86-EPP100
 XE335-L86-EPP200
 XE335-L86-HEP100
 XE335-L86-JOP100
 XE335-L86-SWP100
 XE335-L86-TSP100

ORIGINATED BY: / DATE: /
 CHECKED BY: / DATE: /
 BACK-CHECKED BY: / DATE: /
 11/21/13 | 11:57 AM | FRANKUM
 C:\USERS\PUBLIC\DOCUMENTS\FRANKUM\DRAWINGS\E335-L86-UCP113.DWG

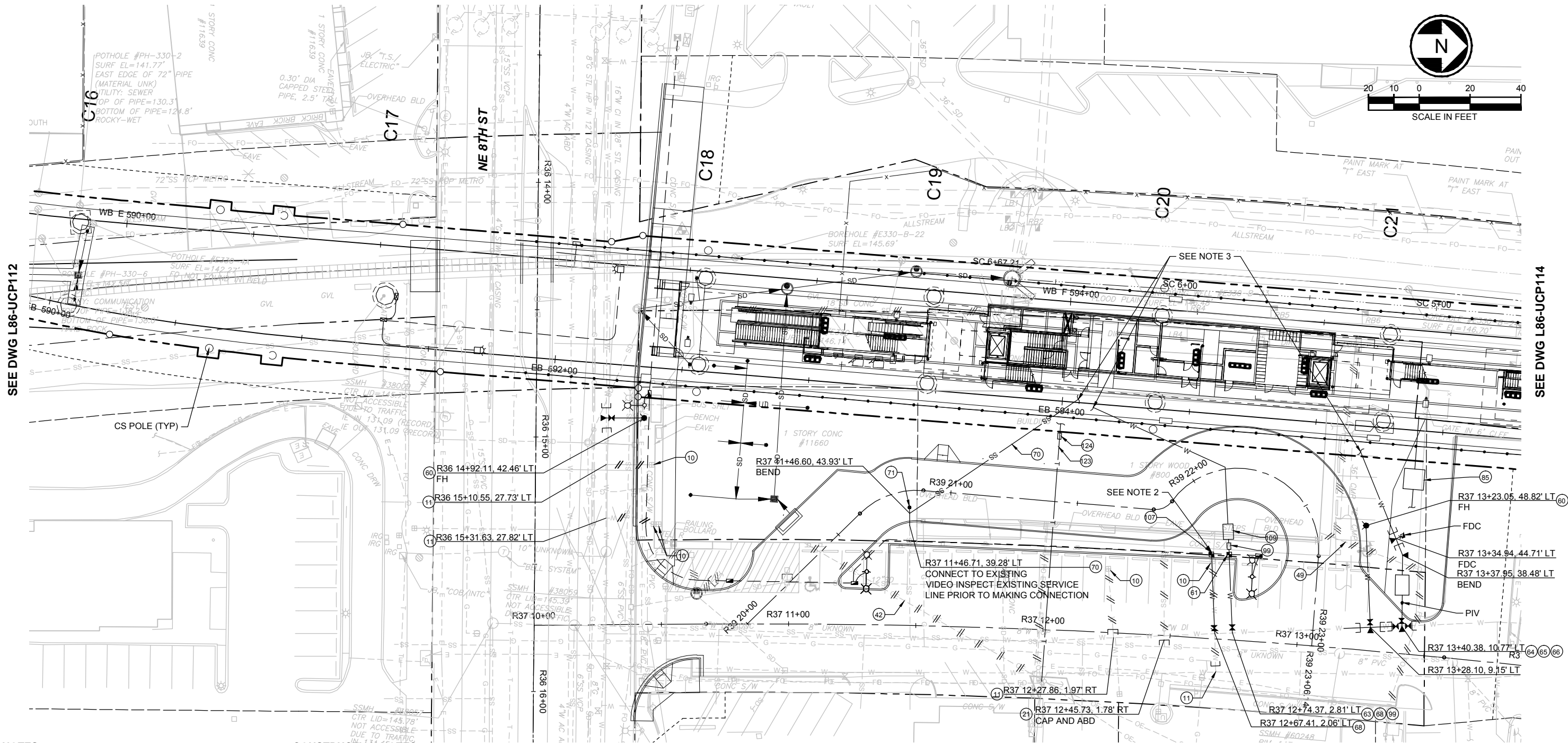
CORRECTED BY: / DATE: /
 VERIFIED BY: / DATE: /



- NOTES:**
- SEE NOTES UZN001 FOR DISCONNECTION / ABANDONMENT / REMOVAL OF UTILITY SERVICES AT BUILDING TO BE DEMOLISHED.
 - SEE HOSPITAL STATION LANDSCAPING DWGS FOR CONTINUATION.
 - SEE HOSPITAL STATION MECHANICAL PLUMBING DWGS FOR CONTINUATION.
- CONSTRUCTION NOTES:**
- (10) RMV EXIST METER BOX
 - (11) RMV SVC CONNECT AND REPAIR
 - (21) ABD SANITARY SIDE SEWER FILL W/CDP
 - (42) PSE TO RMV OH ELEC, NIC.
 - (58) CONST 8" DI WATER MAIN.
 - (60) CONST HYD PER COB STD PLAN W-13.
 - (61) CONST 1.5" DOM WATER SVC PER COB STD PLAN W-26.
 - (64) CONST DI FIRE SVC PER COB STD PLAN W-40.
 - (65) CONST DI 4" FIRE SVC.
 - (66) CONST DCVA PER COB STD PLAN W-45.
 - (68) CONNECT TO EXIST WM.
 - (70) CONST 6" SIDE SEWER.
 - (71) CONST CLEAN OUT PER COB STD PLAN S-16.
 - (85) PSE TO CONST POWER SVC, NIC.
 - (99) CONST PRV PER COB STD PLAN W-21.
 - (107) CONST 2" IRRIG WATER SVC PER COB STD PLAN W-32.
 - (109) CONST DCVA PER COB STD PLAN W-41.
 - (122) CONST 2" PVC CONDUIT (STATION PROVISIONS FOR PUBLIC PHONE SERVICE)
 - (124) CONST TELECOM VLT/JB

60% SUBMITTAL					DESIGNED BY: S. KIRBY DRAWN BY: D. FRANKUM CHECKED BY: J. WEBER APPROVED BY: J. SCHUTT		The VOSK Group LLP Project and Construction Management Consultants	 FINAL DESIGN PARTNERS.		SCALE: 1" = 20' FILENAME: E335-L86-UCP113 CONTRACT No.: RTA/LR XXXX-XX DATE: 12/20/2013	EAST LINK EXTENSION CONTRACT E335 DOWNTOWN BELLEVUE TO SPRING DISTRICT COMPOSITE UTILITY PLAN EB STA 590+00 TO EB STA 595+00	DRAWING No.: L86-UCP113 LOCATION ID: SHEET No.: REV: 0
No.	DATE	DSN	CHK	APP	REVISION							

XREF LIST:
 XE335-L86-CAP100
 XE335-L86-CMP100
 XE335-L86-CSP100
 XE335-L86-LPP100
 XE335-L86-SFP100
 XE335-L86-CDP100
 XE335-L86-APP100
 XE335-L86-APP200
 XE335-L86-APP300
 XE335-L86-APP400
 XE335-L86-APP500
 XE335-L86-APP600
 XE335-L86-APP700
 XE335-L86-APP800
 XE335-L86-APP900
 XE335-L86-APP1000
 XE335-L86-APP1100
 XE335-L86-APP1200
 XE335-L86-APP1300
 XE335-L86-APP1400
 XE335-L86-APP1500
 XE335-L86-APP1600
 XE335-L86-APP1700
 XE335-L86-APP1800
 XE335-L86-APP1900
 XE335-L86-APP2000

ORIGINATED BY: / DATE: /
 CHECKED BY: / DATE: /
 CORRECTED BY: / DATE: /
 VERIFIED BY: / DATE: /
 11/18/13 10:20 AM | FRANKUM | D:
 C:\USERS\PUBLIC\DOCUMENTS\FRANKUM\DRAWINGS\E335-L86-UCP114.DWG

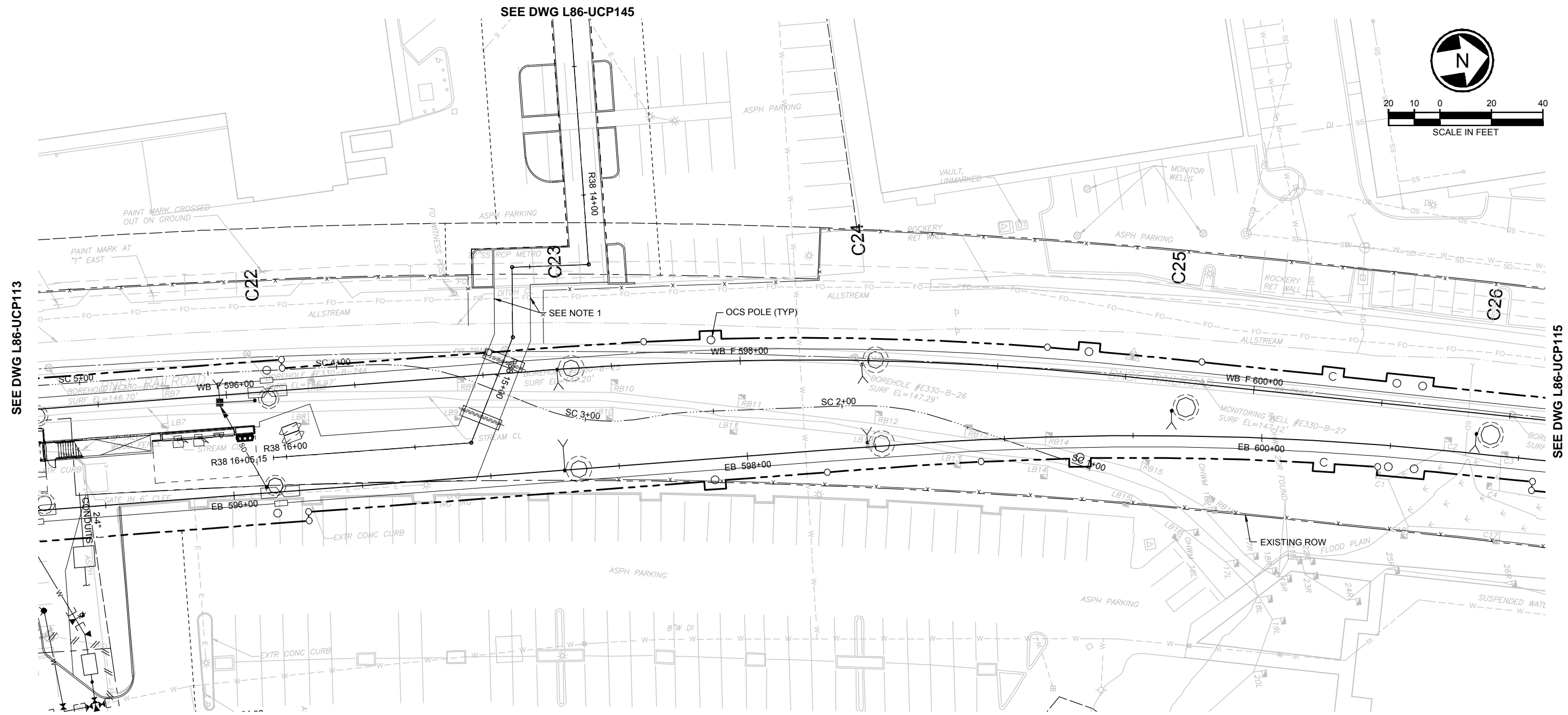
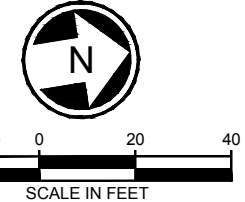

- NOTES:**
1. STAKE ALLSTREAM FIBER OPTIC LINE EITHER SIDE OF PATHWAY. TAKE CARE NOT TO PLACE FORM WORK STAKING WITHIN FIBER OPTIC LINE.

60% SUBMITTAL

DESIGNED BY:
S. KIRBY
 DRAWN BY:
D. FRANKUM
 CHECKED BY:
J. WEBER
 APPROVED BY:
J. SCHUTT



The VOSK Group LLP
 Project and Construction Management Consultants



SCALE:
1" = 20'
 FILENAME:
E335-L86-UCP114
 CONTRACT No.:
RTA/LR XXXX-XX
 DATE:
12/20/2013

**EAST LINK EXTENSION
 CONTRACT E335**
 DOWNTOWN BELLEVUE TO SPRING DISTRICT
 COMPOSITE UTILITY
 PLAN
 EB STA 595+00 TO EB STA 600+00

DRAWING No.:
L86-UCP114
 LOCATION ID:
 SHEET No.: REV:
0

XREF LIST:
 XE335-L86-CAP100
 XE335-L86-CMP100
 XE335-L86-LPP100
 XE335-L86-SFP100
 XE335-L86-UCP100
 XE335-L86-CDP100
 XEL-0531rf
 XEL-0531uf
 XE335-08-TB22x34
 XE335-L86-RPP100
 XE335-L86-CRP100
 CB-SEAL-SAK37898
 XE335-L86-CLP100
 XE335-L86-EPP100
 XE335-L86-EPP300
 XE335-L86-EP100
 XE335-L86-JOP100
 XE335-L86-SWP100
 XE335-L86-TSP100
 XE335-L86-KAP100

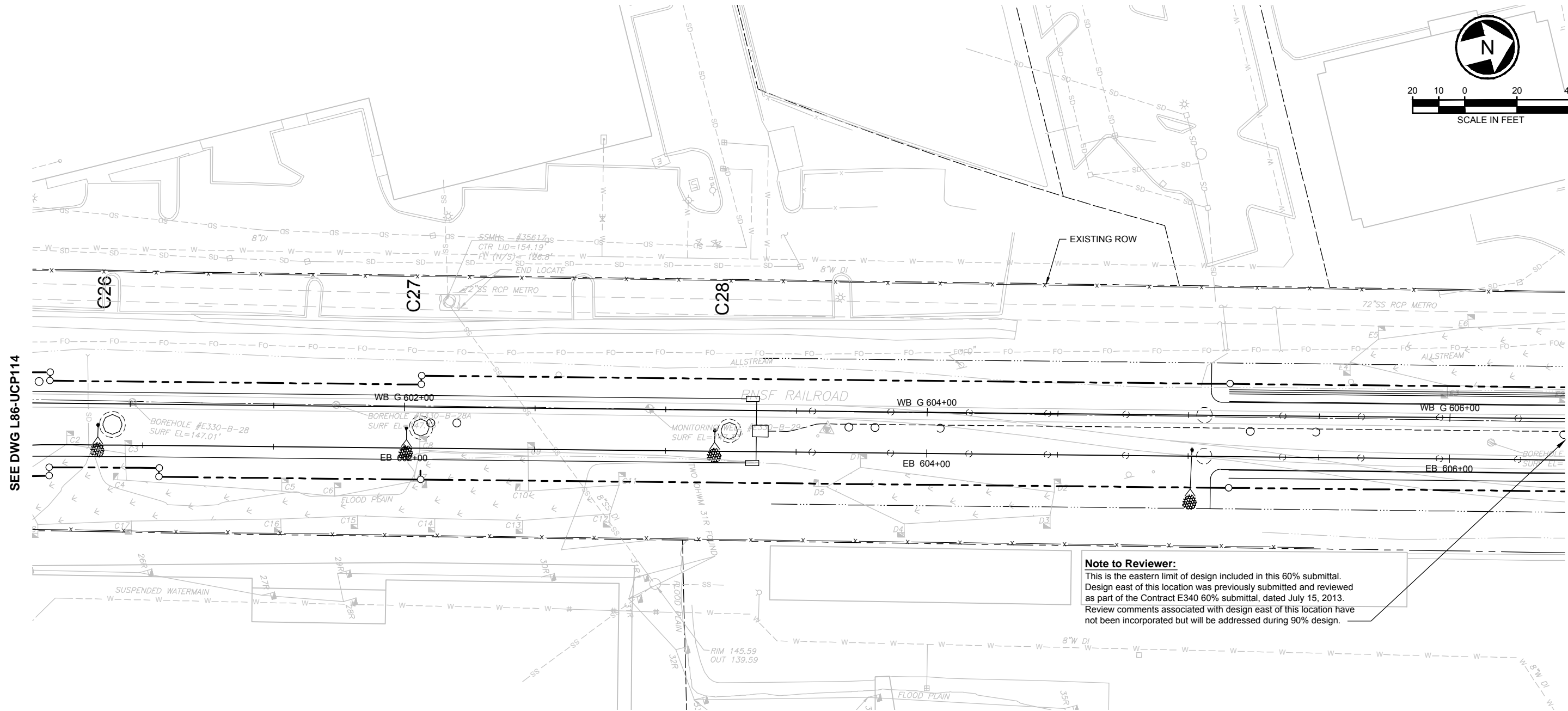
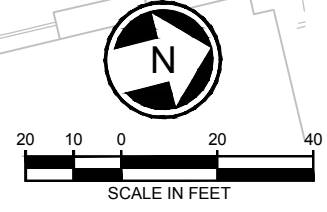

SEE DWG L86-UCP114

Note to Reviewer:
 This is the eastern limit of design included in this 60% submittal. Design east of this location was previously submitted and reviewed as part of the Contract E340 60% submittal, dated July 15, 2013. Review comments associated with design east of this location have not been incorporated but will be addressed during 90% design.

ORIGINATED BY: / DATE: /
 CHECKED BY: / DATE: /
 BACK-CHECKED BY: / DATE: /
 12/10/13 | 3:00 PM | FRANKUMD
 C:\USERS\PUBLIC\DOCUMENTS\FRANKUMD\FRANKUMD\HTT\PS\SHARPOINT\SOUNDTRANSIT.ORG\44\SITES\CAD\EL\BEL\RED\E335\DRAWINGS\E335-L86-UCP115.DWG

60% SUBMITTAL

DESIGNED BY:
S. KIRBY
 DRAWN BY:
D. FRANKUM
 CHECKED BY:
J. WEBER
 APPROVED BY:
J. SCHUTT



The VOSK Group LLP
 Project and Construction Management Consultants

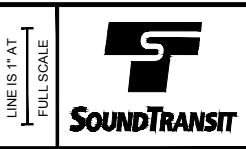
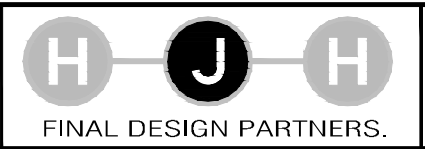

SCALE:
1" = 20'
 FILENAME:
E335-L86-UCP115
 CONTRACT No.:
RTA/LR XXXX-XX
 DATE:
12/20/2013

**EAST LINK EXTENSION
 CONTRACT E335**
 DOWNTOWN BELLEVUE TO SPRING DISTRICT
 COMPOSITE UTILITY
 PLAN
 EB STA 600+00 TO EB STA 605+00

DRAWING No.:
L86-UCP115
 LOCATION ID:
 SHEET No.: REV:
0

No.	DATE	DSN	CHK	APP	REVISION

XREF LIST:
 XE335-E19-APP100
 XE335-L86-SFP100
 XE335-E19-SGP100
 XE335-L86-SFP100
 XEL-0525rx
 XEL-0525sf
 XEL-0525ut
 XEL-0528rx
 XEL-0528sf
 XEL-0528ut
 XE335-GB-TB22x34
 XE335-L86-CRP100
 XEL-0228rx
 XEL-0228sf
 XEL-0228ut
 XEL-0531rx
 XEL-0531sf
 XEL-0531ut
 XE335-L86-TCP100
 XE335-L86-TMP101
 XE335-L86-CCP100
 GB-SEAL-NCWC4107

ORIGINATED BY: / DATE: /
 CHECKED BY: / DATE: /
 BACK-CHECKED BY: / DATE: /
 11/22/13 | 3:16 PM | CALDWELL
 C:\USERS\PUBLIC\DOCUMENTS\CALDWELL\HTTSP\SHAREPOINT\ SOUNDTRANSIT\ORG\443\SITES\CAD\EL\BEL\RED\E335-L86-TMP101.DWG

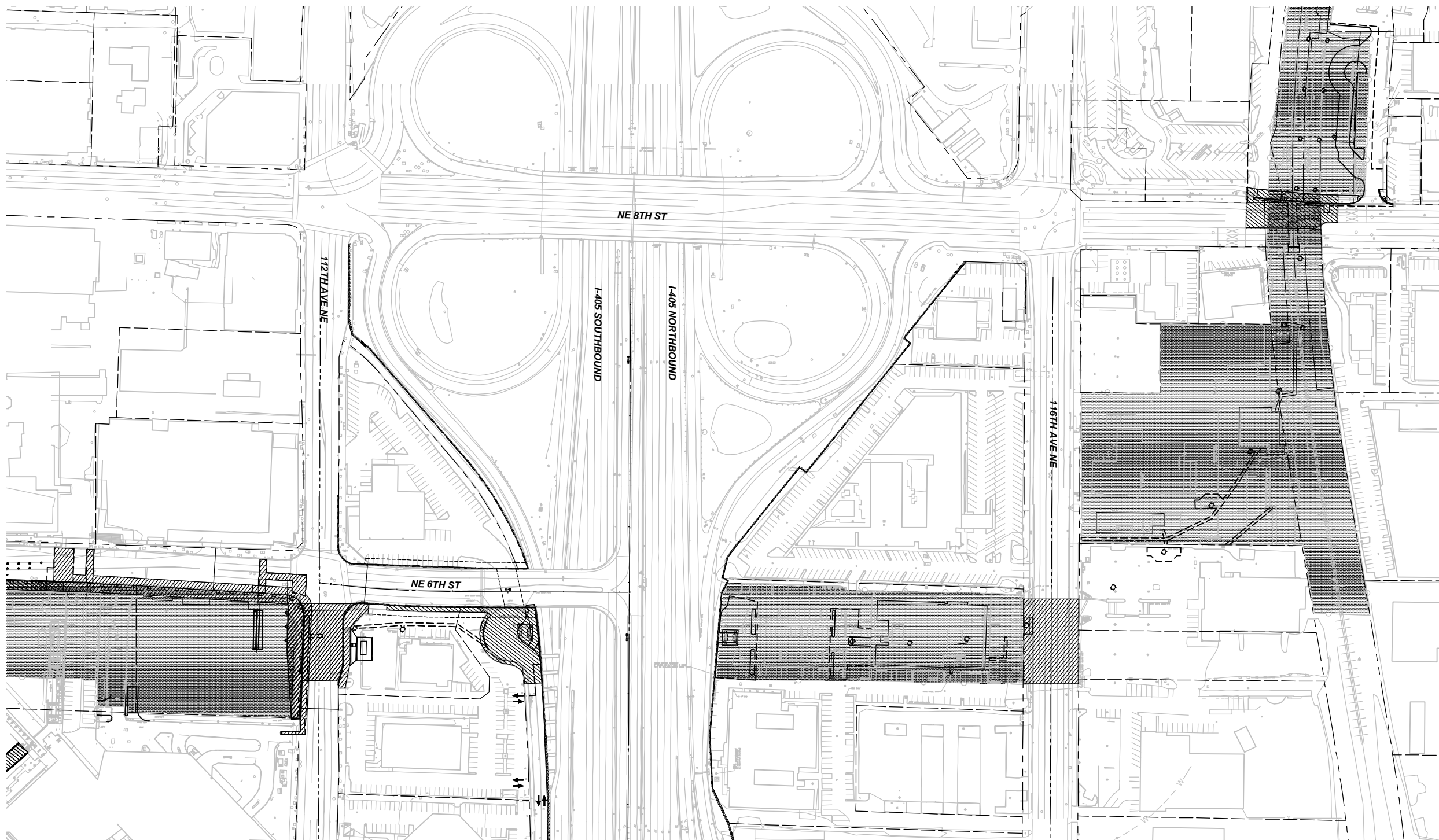

LEGEND:
 WORK ZONE STREET CLOSURE
 CONSTRUCTION STAGING AREA

NOTES:
 1. ADA PEDESTRIAN ACCESS TO BE MAINTAINED ON ONE SIDE OF STREET IN WORK ZONE CLOSURE, MINIMUM, AND ALONG RETAIL BUSINESS FRONTAGE AND RESIDENTIAL BUILDINGS.
 2. TEMPORARY RELOCATION LOCATIONS OF FIRE HYDRANTS AND FIRE DEPARTMENT CONNECTIONS TO BE DETERMINED.
 3. CONTRACTOR TO PROVIDE TEMPORARY ILLUMINATION. SEE CONTRACT SPECIFICATIONS.

NE 8TH ST, 116TH AVE NE, & 118TH AVE NE CLOSURES
 SCALE: 1" = 100'

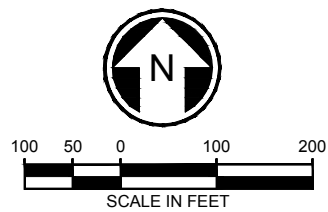

60% SUBMITTAL

DESIGNED BY:
N. CHING
 DRAWN BY:
R. JOHNSON
 CHECKED BY:
B. JAMES
 APPROVED BY:
J. SCHUTT



LINE IS 1" AT FULL SCALE



SCALE:
1" = 100'
 FILENAME:
E335-L86-TMP101
 CONTRACT No.:
RTA/LR XXXX-XX
 DATE:
12/20/2013

**EAST LINK EXTENSION
 CONTRACT E335**
 DOWNTOWN BELLEVUE TO SPRING DISTRICT
 MAINTENANCE OF TRAFFIC
 TRAFFIC STAGING PLAN CONCEPT KEY MAP
 NE 6TH ST TO 116TH AVE NE

DRAWING No.:
L86-TMP101
 LOCATION ID:
 SHEET No.: REV:
0

No.	DATE	DSN	CHK	APP	REVISION

SIGN SPACING = X (FEET) (1)

FREEWAYS & EXPRESSWAYS	55/70 MPH	1500' (1)
URBAN ARTERIALS	35/40 MPH	350' (1)
URBAN STREETS RESIDENTIAL & BUSINESS DISTRICTS	25/30 MPH	200' (1) (2)
URBAN STREETS	25 MPH OR LESS	100' (1) (2)

- ALL SIGNS ARE 48"x48" BLACK ON ORANGE UNLESS OTHERWISE DESIGNATED
- ALL SPACING MAY BE ADJUSTED TO ACCOMMODATE INTERCHANGE RAMP, AT-GRADE INTERSECTIONS, AND DRIVEWAYS.
 - THIS SPACING MAY BE REDUCED IN URBAN AREAS TO FIT ROADWAY CONDITIONS.

MINIMUM TAPER LENGTH = L (feet)

LANE WIDTH (feet)	POSTED SPEED (mph)									
	25	30	35	40	45	50	55	60	65	70
10	105	150	205	270	450	500	550	-	-	-
11	115	165	225	295	495	550	605	660	-	-
12	125	180	245	320	540	600	660	720	780	840

CHANNELIZING DEVICE SPACING (FEET)

MPH	TAPER	TANGENT
50/70	40	80
35/45	30	60
25/30	20	40

XREF LIST:
 XE335-E19-APP100
 XE335-E19-SFP100
 XE335-E19-SGP100
 XE335-L86-CAP100
 XE335-L86-KAP100
 XE335-OB-TB22x34
 XE335-E11-APP100
 XE335-L86-TCF100
 GB-SEAL-NCWC4107

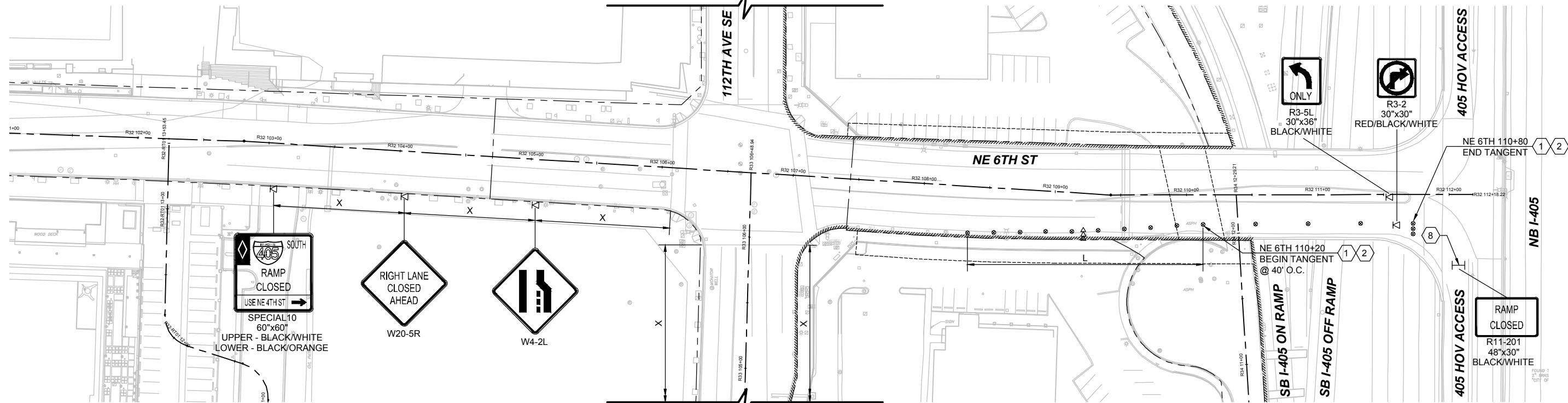
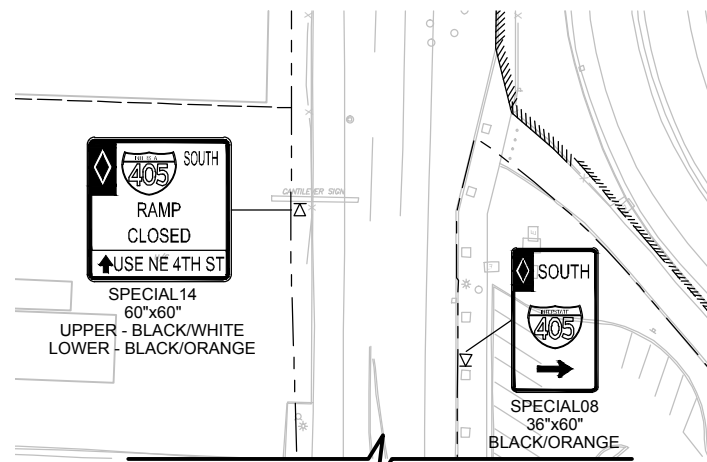

CONSTRUCTION NOTES:

- USE STEADY BURNING WARNING LIGHTS (TYPE C, MUTCD) ON CHANNELIZING DEVICES AT NIGHT FOR DELINEATION.
- TRAFFIC SAFETY DRUMS.
- TYPE III BARRICADE.

NOTES:

- DEVICES SHALL NOT ENCROACH INTO ADJACENT LANES.
- ALLOWABLE WORK HOURS AS PER SPECIAL CONDITIONS.
- SEE SHEET L86-TZN001 FOR LEGEND.
- NO FLAGGERS OR SPOTTERS THIS SHEET.
- NE 6TH HOV DIRECT ACCESS RAMP CLOSURE ONLY PERMITTED DURING TIMES SPECIFIED IN THE SPECIAL CONDITIONS.
- SEE SHEETS XXX THRU XXX FOR CONSTRUCTION SIGN DETAILS.

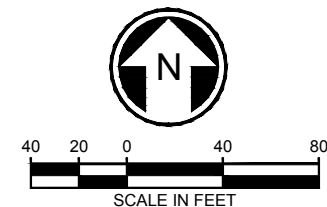

ORIGINATED BY: / DATE: /
 CHECKED BY: / DATE: /
 BACK-CHECKED BY: / DATE: /
 11/22/13 | 3:20 PM | CALDWELL
 C:\USERS\PUBLIC\DOCUMENTS\CALDWELL\HNTB\SHARPOINT\SOUNDTRANSIT\ORG\443\SITES\CAD\ELBEL\RED\E335-L86-TMP209.DWG

60% SUBMITTAL

DESIGNED BY:
N. CHING
 DRAWN BY:
R. JOHNSON
 CHECKED BY:
B. JAMES
 APPROVED BY:
J. SCHUTT



LINE IS 1" AT FULL SCALE



SCALE:
1" = 40'
 FILENAME:
E335-L86-TMP209
 CONTRACT No.:
RTA/LR XXXX-XX
 DATE:
12/20/2013

**EAST LINK EXTENSION
 CONTRACT E335**
 DOWNTOWN BELLEVUE TO SPRING DISTRICT
 MAINTENANCE OF TRAFFIC
 TRAFFIC CONTROL PLAN
 NE 6TH ST RAMP ON-RAMP CLOSURE

DRAWING No.:
L86-TMP209
 LOCATION ID:
 SHEET No.: REV:
0

XREF LIST:
 XE335-E19-APP100
 XE335-E19-SFP100
 XE335-E19-SGP100
 XE335-L86-CAP100
 XE335-L86-CMP100
 XE335-L86-SFP100
 XEL-0525rx
 XEL-0525sf
 XEL-0525ut
 XEL-0528rx
 XEL-0528sf
 XEL-0528ut
 XE335-019-TB22x34
 XE335-L86-CRP100
 XEL-0228rx
 XEL-0228sf
 XEL-0228ut
 XEL-0531rx
 XEL-0531sf
 XEL-0531ut
 XE335-L86-TCP100
 XE335-L86-TMP101
 XE335-L86-CPP100
 GB-SEAL-NCWVC4107

ORIGINATED BY: / DATE: /
 CORRECTED BY: / DATE: /
 VERIFIED BY: / DATE: /
 11/22/13 3:20 PM | CALDWELL
 C:\USERS\PUBLIC\DOCUMENTS\CALDWELL\HNTB\HNTB\SHAREPOINT\SOUNDTRANSIT\ORG\443\SITES\CAD\ELBEL\RED\E335-L86-TMP210.DWG

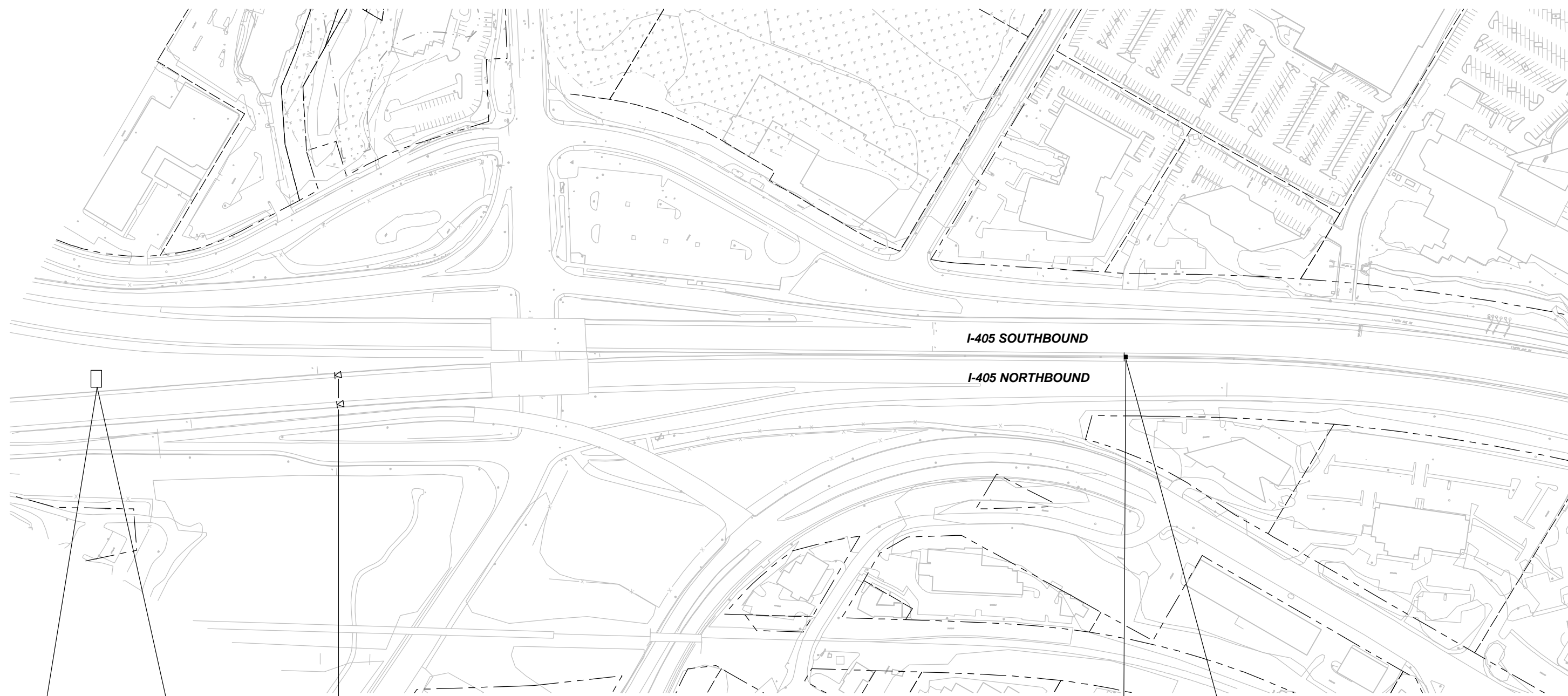

PCMS	
1	2
NE 6TH HOV RAMP CLOSED	FOLLOW DETOUR
1.5 SEC	1.5 SEC

DURING CLOSURE

PCMS	
1	2
NE 6TH HOV RAMP	13'-6" MAX
1.5 SEC	1.5 SEC

WHEN GUIDEWAY FALSEWORK REDUCES CLEARANCE



GENERAL NOTES:

1. DEVICES SHALL NOT ENCR OACH INTO ADJACENT LANES.
2. ALLOWABLE WORK HOURS AS PER SPECIAL CONDITIONS.
3. SEE SHEET L86-TZN001 FOR LEGEND.
4. NO FLAGGERS OR SPOTTERS THIS SHEET.
5. NE 6TH HOV DIRECT ACCESS RAMP CLOSURE ONLY DURING TIMES SPECIFIED IN THE SPECIAL CONDITIONS.



MOUNT ON MEDIAN BARRIER WHEN GUIDEWAY FALSEWORK REDUCES CLEARANCE

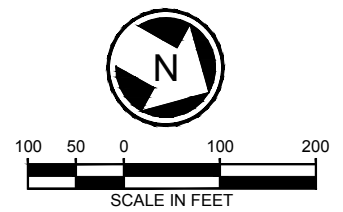

SEE DWG L86-TMP211

60% SUBMITTAL

DESIGNED BY:
N. CHING
DRAWN BY:
R. JOHNSON
CHECKED BY:
B. JAMES
APPROVED BY:
J. SCHUTT

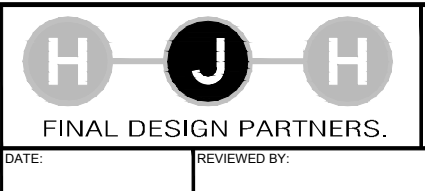

LINE IS 1" AT FULL SCALE



SCALE:
1" = 100'
FILENAME:
E335-L86-TMP210
CONTRACT No.:
RTA/LR XXXX-XX
DATE:
12/20/2013

**EAST LINK EXTENSION
CONTRACT E335**
DOWNTOWN BELLEVUE TO SPRING DISTRICT
**MAINTENANCE OF TRAFFIC
TRAFFIC CONTROL PLAN
NE 6TH ST RAMP OFF-RAMP CLOSURE**

DRAWING No.:
L86-TMP210
LOCATION ID:
SHEET No.:
REV:
0

XREF LIST:
 XE335-E19-SFP100
 XE335-E19-SCP100
 XE335-L86-CMP100
 XE335-L86-SFP100
 XEL-0525rx
 XEL-0525sf
 XEL-0525ut
 XEL-0528rx
 XEL-0528sf
 XEL-0528ut
 XE335-GB-TB22x34
 XE335-L86-CRP100
 XEL-0228rx
 XEL-0228sf
 XEL-0228ut
 XEL-0531rx
 XEL-0531sf
 XEL-0531ut
 XE335-L86-TCP100
 XE335-L86-TMP101
 XE335-L86-CCP100
 GB-SEAL-NCWC4107

SEE DWG L86-TMP210

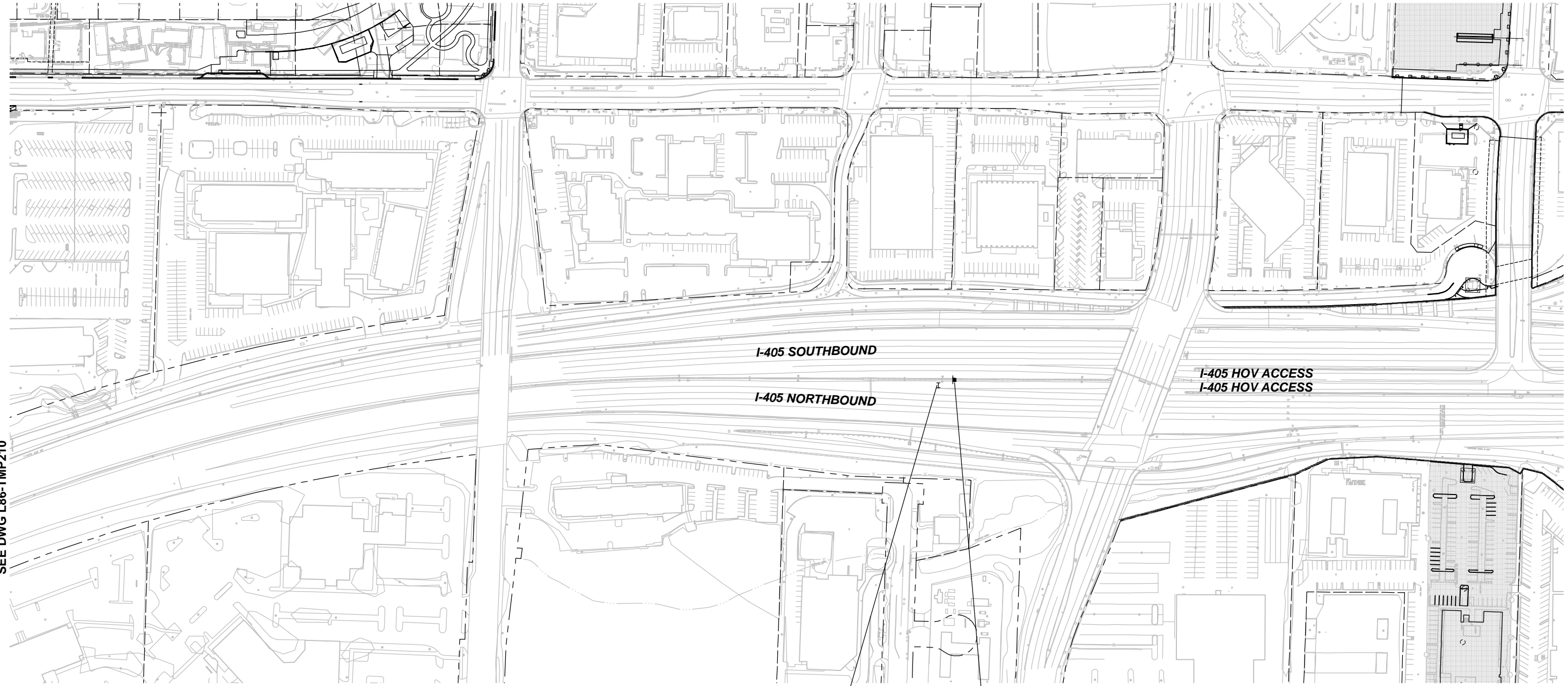

ORIGINATED BY: / DATE: /
 CORRECTED BY: / DATE: /
 VERIFIED BY: / DATE: /

BACK-CHECKED BY: / DATE: /
 11/22/13 | 3:21 PM | CALDWELL
 C:\USERS\PUBLIC\DOCUMENTS\CALDWELL\HNTB\SHARPOINT\SOUNDTRANSIT\ORG\443\SITES\CAD\ELBEL\RED\E335-L86-TMP211.DWG

GENERAL NOTES:

1. DEVICES SHALL NOT ENCROACH INTO ADJACENT LANES.
2. ALLOWABLE WORK HOURS AS PER SPECIAL CONDITIONS.
3. SEE SHEET L86-TZN001 FOR LEGEND.
4. NO FLAGGERS OR SPOTTERS THIS SHEET.
5. NE 6TH HOV DIRECT ACCESS RAMP CLOSURE ONLY DURING TIMES SPECIFIED IN THE SPECIAL CONDITIONS.

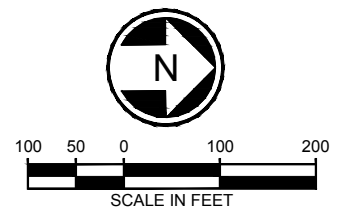
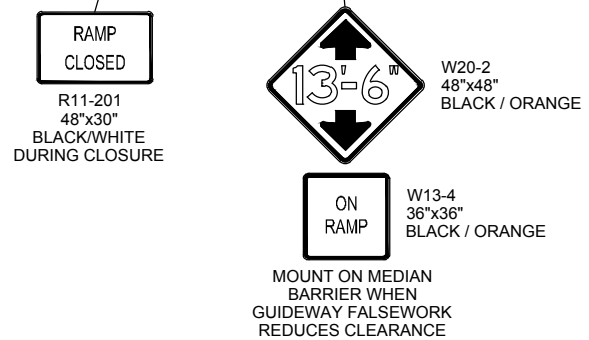

60% SUBMITTAL

DESIGNED BY:
N. CHING
 DRAWN BY:
R. JOHNSON
 CHECKED BY:
B. JAMES
 APPROVED BY:
J.SCHUTT



LINE IS 1" AT FULL SCALE



SCALE:
1" = 100'
 FILENAME:
E335-L86-TMP211
 CONTRACT No.:
RTA/LR XXXX-XX
 DATE:
12/20/2013

**EAST LINK EXTENSION
 CONTRACT E335**
 DOWNTOWN BELLEVUE TO SPRING DISTRICT
 MAINTENANCE OF TRAFFIC
 TRAFFIC CONTROL PLAN
 NE 6TH ST RAMP OFF-RAMP CLOSURE

DRAWING No.:
L86-TMP211
 LOCATION ID:
 SHEET No.: REV:
0

No.	DATE	DSN	CHK	APP	REVISION

SEE DWG L86-TNP102

XREF LIST:
 XE330-E15-SFP400
 XE335-E19-APP100
 XE335-E19-SFP100
 XE335-E19-SGP100
 XE335-L86-CMP100
 XE335-L86-KAP100
 XE335-L86-SFP100
 XE335-L86-UCP100
 XE335-L86-CDP100
 XEL-0525x
 XEL-0525f
 XEL-0525u
 XEL-0528x
 XEL-0528f
 XEL-0528u
 XE330-L85-KAP100
 XE335-GB-1B22-34
 XE335-E11-APP100
 XE335-L86-CPP100
 XE335-L86-CRP100
 XEL-0228x
 XEL-0228f
 XEL-0228u
 XEL-0531x
 XEL-0531f
 XEL-0531u
 XE335-L86-TNP101
 XE330-T86-STP001
 XE330-T86-STP002
 XE330-T86-CAP100
 XE335-L86-SWP100
 XE330-T86-SWP100
 GB-SEAL-WU24615

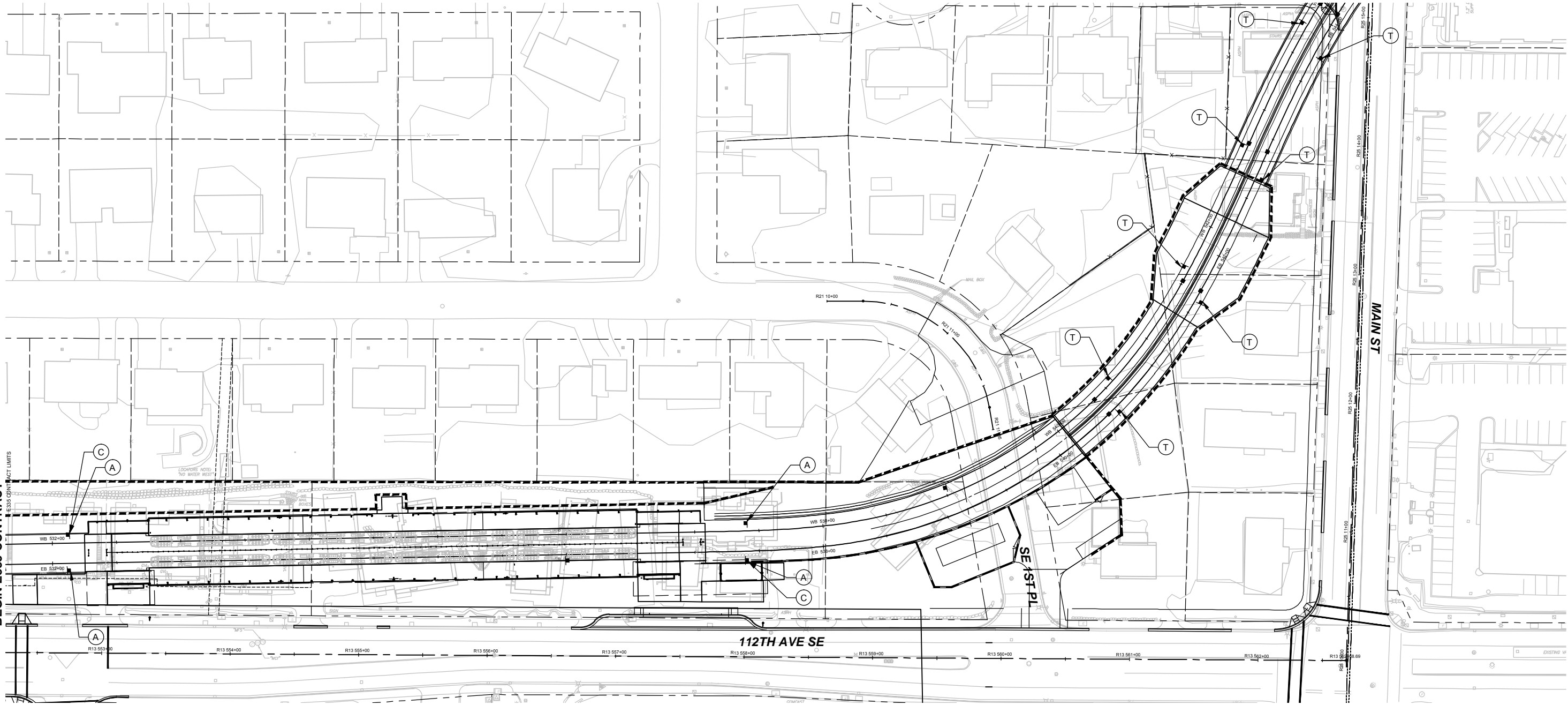

END E320 CONTRACT
 BEGIN E335 CONTRACT

NOTES:

1. REFER TO SHEETS L86-TND001, L86-TND002, AND L86-TND003 FOR OPERATIONAL SIGNAGE DETAILS.
2. REFER TO SHEET L86-TNS001 FOR OPERATIONAL SIGNAGE SCHEDULE.

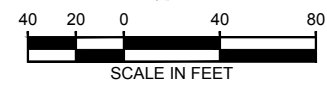

ORIGINATED BY: / DATE: /
 CHECKED BY: / DATE: /
 BACK-CHECKED BY: / DATE: /
 11/20/13 11:15 AM | CALDWELL
 C:\USERS\PUBLIC\DOCUMENTS\CALDWELL\HTTTPS\SHAREPOINT\SOUNDTRANSIT\ORG\443\SITES\CAD\EL\RED\E335\DRAWINGS\E335-L86-TNP101.DWG

60% SUBMITTAL

DESIGNED BY:
L. BARTA
 DRAWN BY:
R. JOHNSON
 CHECKED BY:
B. JAMES
 APPROVED BY:
J. SCHUTT

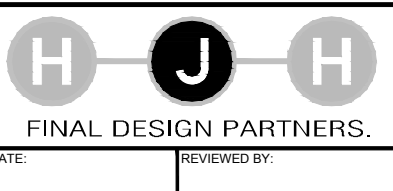
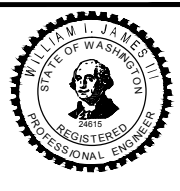

LINE IS 1" AT FULL SCALE



SCALE:
1" = 40'
 FILENAME:
E335-L86-TNP101
 CONTRACT No.:
RTA/LR XXXX-XX
 DATE:
12/20/2013

**EAST LINK EXTENSION
 CONTRACT E335**
 DOWNTOWN BELLEVUE TO SPRING DISTRICT
 TRAFFIC
 OPERATIONAL SIGNAGE

DRAWING No.:
L86-TNP101
 LOCATION ID:
 SHEET No.: REV:
0

No.	DATE	DSN	CHK	APP	REVISION

XREF LIST:
 XE330-E15-SFP400
 XE335-E19-APP100
 XE335-E19-SFP100
 XE335-E19-SGP100
 XE335-L86-CAP100
 XE335-L86-CMP100
 XE335-L86-KAP100
 XE335-L86-SFP100
 XEL-0525r
 XEL-0525f
 XEL-0525u
 XEL-0528r
 XEL-0528f
 XEL-0528u
 XE335-GB-TB22x34
 XE335-E11-APP100
 XE335-L86-CRP100
 XEL-0228r
 XEL-0228f
 XEL-0228u
 XEL-0531r
 XEL-0531f
 XEL-0531u
 XE335-L86-TNP101
 XE330-T86-STP001
 XE330-T86-STP002
 GB-SEAL-WLJ24615

ORIGINATED BY: / DATE: /
 CHECKED BY: / DATE: /
 CORRECTED BY: / DATE: /
 VERIFIED BY: / DATE: /
 11/20/13 | 11:16 AM | CALDWELL
 C:\USERS\PUBLIC\DOCUMENTS\CALDWELL\HNTB\SHAREPOINT_SOUNDTRANSIT\ORG\443\SITES\CAD\BELRED\E335\DRAWINGS\E335-L86-TNP102.DWG

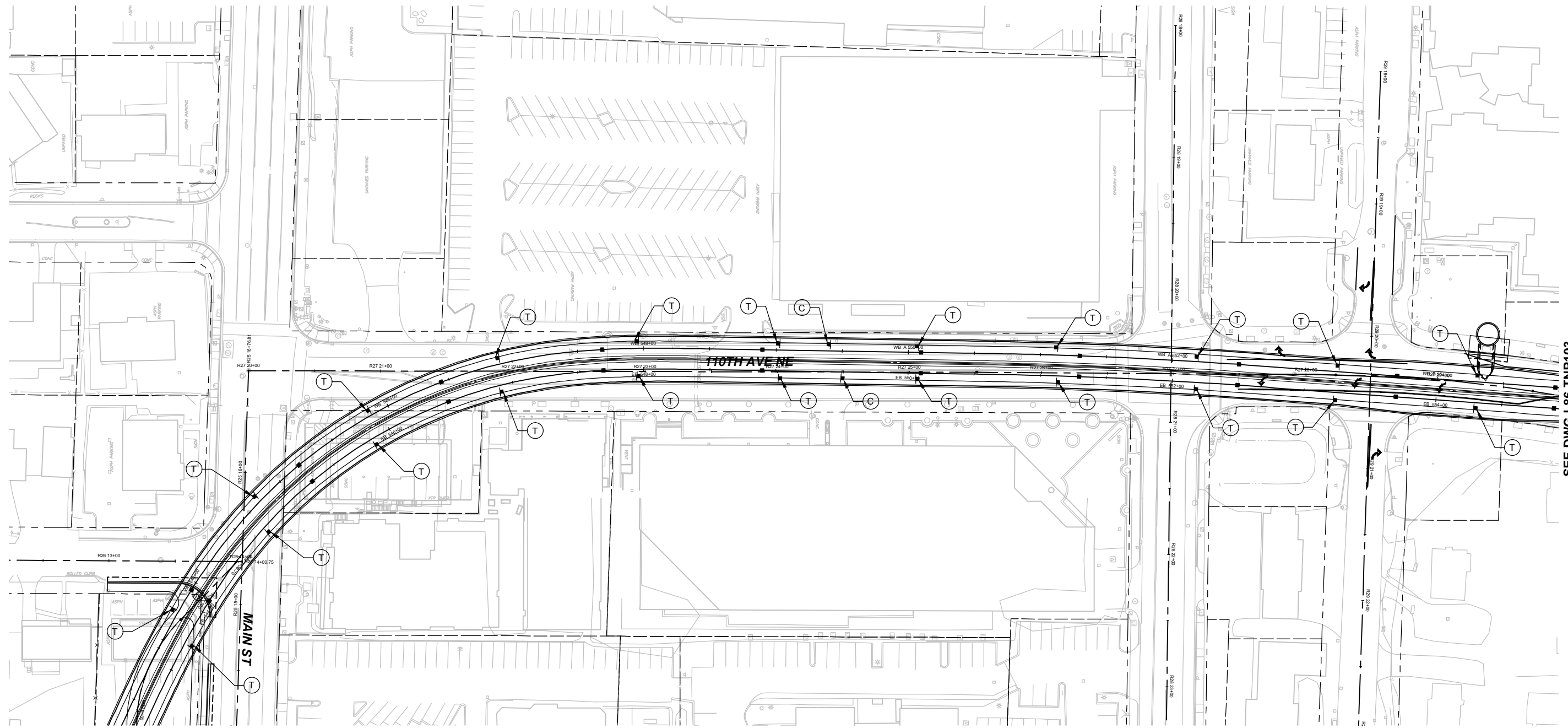

SEE DWG L86-TNP101

SEE DWG L86-TNP103

- NOTES:**
- REFER TO SHEETS L86-TND001, L86-TND002, AND L86-TND003 FOR OPERATIONAL SIGNAGE DETAILS.
 - REFER TO SHEET L86-TNS001 FOR OPERATIONAL SIGNAGE SCHEDULE.

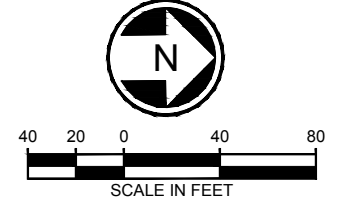

60% SUBMITTAL

DESIGNED BY:
L. BARTA
 DRAWN BY:
R. JOHNSON
 CHECKED BY:
B. JAMES
 APPROVED BY:
J. SCHUTT



LINE IS 1" AT FULL SCALE



SCALE:
1" = 40'
 FILENAME:
E335-L86-TNP102
 CONTRACT No.:
RTA/LR XXXX-XX
 DATE:
12/20/2013

**EAST LINK EXTENSION
 CONTRACT E335**
 DOWNTOWN BELLEVUE TO SPRING DISTRICT
 TRAFFIC
 OPERATIONAL SIGNAGE

DRAWING No.:
L86-TNP102
 LOCATION ID:
 SHEET No.: REV:
0

No.	DATE	DSN	CHK	APP	REVISION

XREF LIST:
 XE330-E15-SFP400
 XE335-E19-APP100
 XE335-E19-SFP100
 XE335-E19-SGP100
 XE335-L86-CAP100
 XE335-L86-CMP100
 XE335-L86-KAP100
 XE335-L86-SFP100
 XEL-0525fx
 XEL-0525sf
 XEL-0525ut
 XEL-0528fx
 XEL-0528sf
 XEL-0528ut
 XE320-L85-KAP100
 XE335-GB-TEZZX04
 XE335-E11-APP100
 XE335-L86-CPP100
 XE335-L86-CRP100
 XEL-0228fx
 XEL-0228sf
 XEL-0228ut
 XEL-0531fx
 XEL-0531sf
 XEL-0531ut
 XE330-T86-STP001
 XE330-T86-STP002
 GB-SEAL-WUL24E15
 XE335-L86-TNP101

ORIGINATED BY: / DATE: /
 CHECKED BY: / DATE: /
 CORRECTED BY: / DATE: /
 BACK-CHECKED BY: / DATE: /
 VERIFIED BY: / DATE: /
 11/20/13 | 11:16 AM | CALDWELL
 C:\USERS\PUBLIC\DOCUMENTS\CALDWELL\HTTTPS\SHAREPOINT\ SOUNDTRANSIT\ORG\443\SITES\CAD\BEL\RED\E335\DRAWINGS\E335-L86-TNP103.DWG

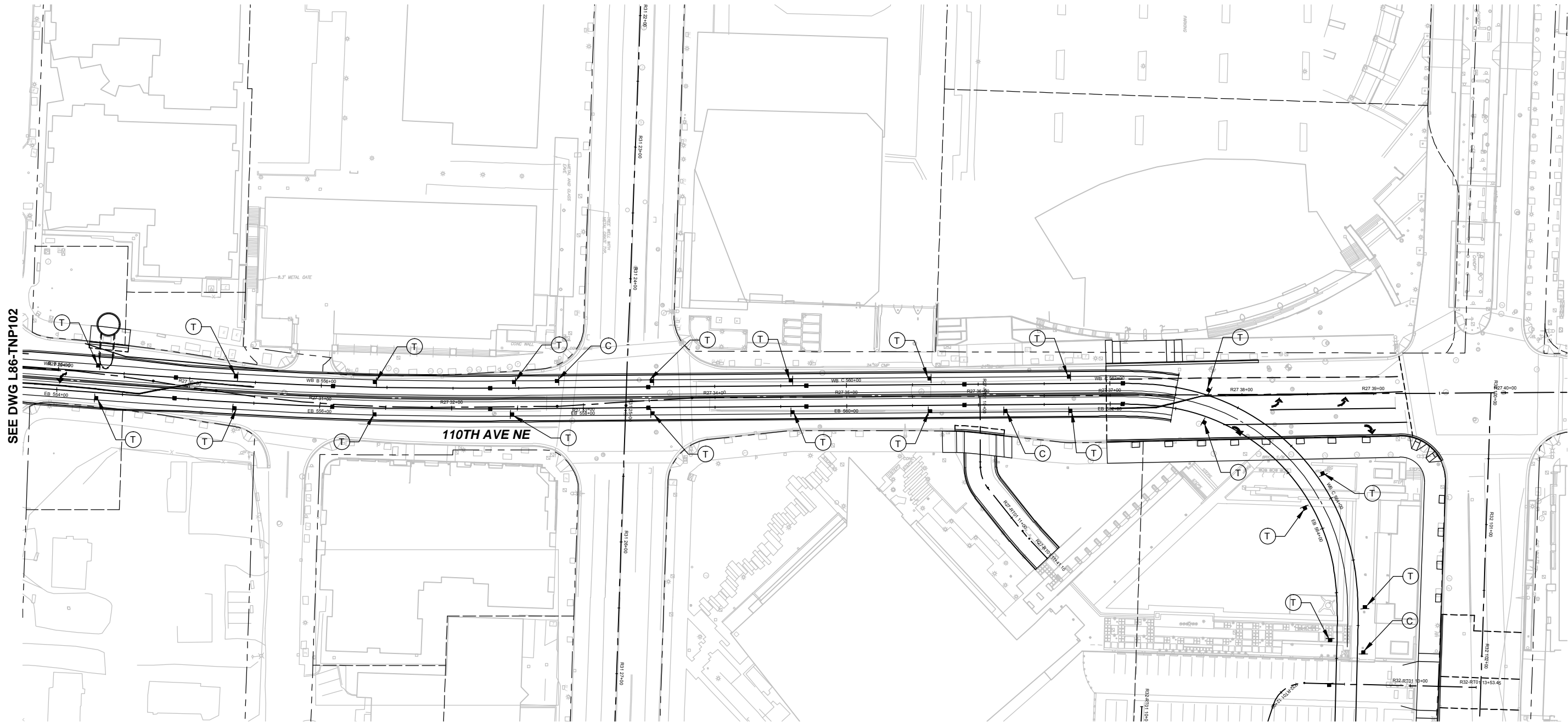

SEE DWG L86-TNP102

SEE DWG L86-TNP104

- NOTES:**
- REFER TO SHEETS L86-TND001, L86-TND002, AND L86-TND003 FOR OPERATIONAL SIGNAGE DETAILS.
 - REFER TO SHEET L86-TNS001 FOR OPERATIONAL SIGNAGE SCHEDULE.

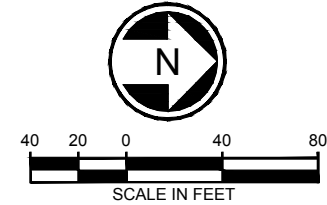

60% SUBMITTAL

DESIGNED BY:
L. BARTA
 DRAWN BY:
R. JOHNSON
 CHECKED BY:
B. JAMES
 APPROVED BY:
J. SCHUTT



LINE IS 1" AT FULL SCALE



SCALE:
1" = 40'
 FILENAME:
E335-L86-TNP103
 CONTRACT No.:
RTA/LR XXXX-XX
 DATE:
12/20/2013

**EAST LINK EXTENSION
 CONTRACT E335**
 DOWNTOWN BELLEVUE TO SPRING DISTRICT
 TRAFFIC
 OPERATIONAL SIGNAGE

DRAWING No.:
L86-TNP103
 LOCATION ID:
 SHEET No.: REV:
0

XREF LIST:
 XE330-E15-SFP400
 XE335-E19-APP100
 XE335-E19-SFP100
 XE335-E19-SGP100
 XE335-L86-CAP100
 XE335-L86-CMP100
 XE335-L86-KAP100
 XE335-L86-SFP100
 XE335-L86-UCP100
 XE335-L86-CRP100
 XEL-0525x
 XEL-0525sf
 XEL-0528x
 XEL-0528sf
 XEL-0528ut
 XE330-L86-KAP100
 XE335-GB-TB22x34
 XE335-E11-APP100
 XE335-L86-CRP100
 XE335-L86-CRP100
 XEL-0228x
 XEL-0228sf
 XEL-0228ut
 XEL-0531x
 XEL-0531sf
 XE335-L86-TNP101
 GB-SEAL-WU24615

ORIGINATED BY: / DATE: /
 CHECKED BY: / DATE: /
 BACK-CHECKED BY: / DATE: /
 11/20/13 11:17 AM | CALDWELL
 C:\USERS\PUBLIC\DOCUMENTS\CALDWELL\HTTTPS\SHAREPOINT\SOUNDTRANSIT\ORG\443\SITES\CAD\EL\BEL\RED\E335\L86-TNP104.DWG

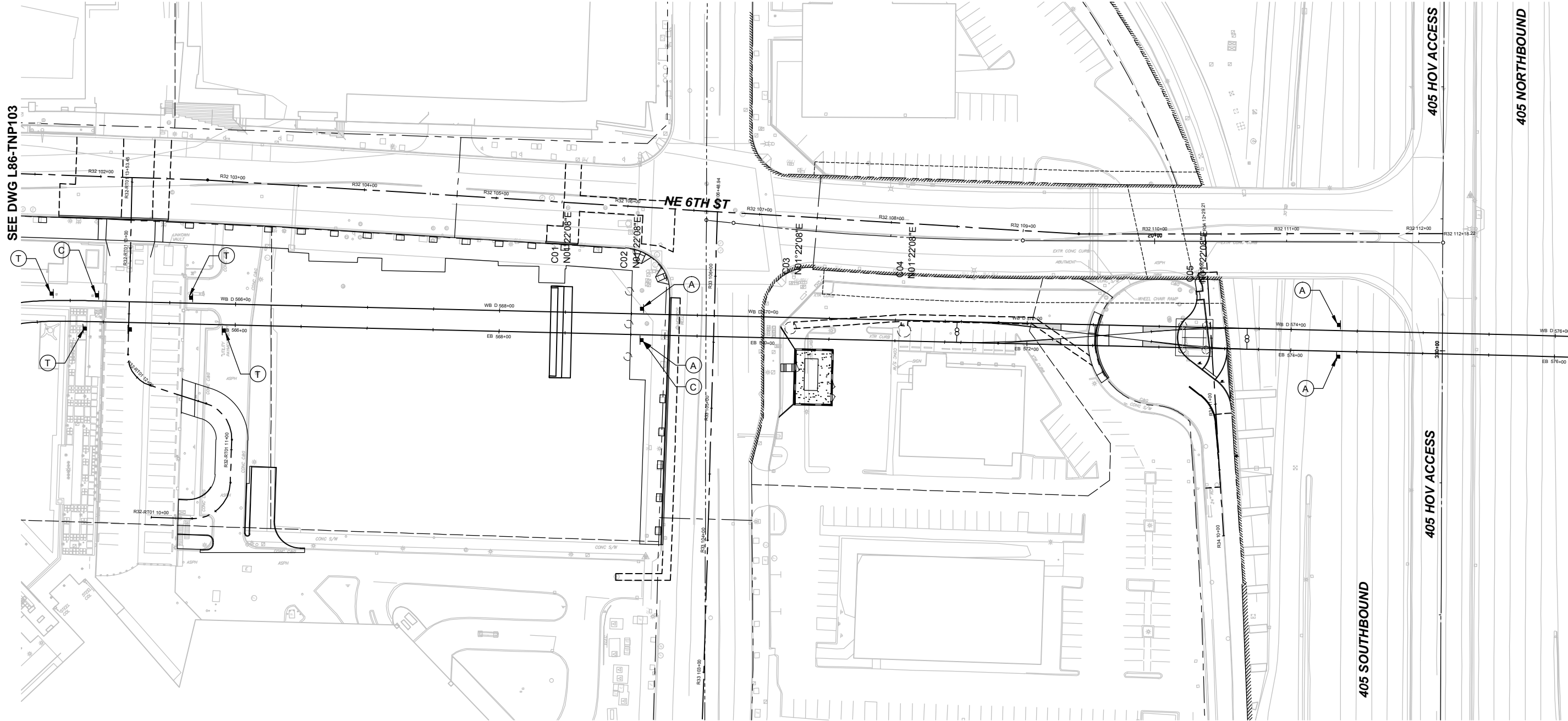

- NOTES:**
- REFER TO SHEETS L86-TND001, L86-TND002, AND L86-TND003 FOR OPERATIONAL SIGNAGE DETAILS.
 - REFER TO SHEET L86-TNS001 FOR OPERATIONAL SIGNAGE SCHEDULE.

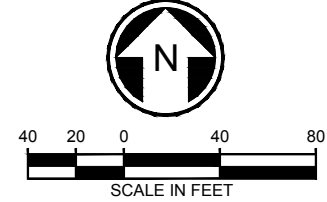

60% SUBMITTAL

DESIGNED BY:
L. BARTA
 DRAWN BY:
R. JOHNSON
 CHECKED BY:
B. JAMES
 APPROVED BY:
J. SCHUTT

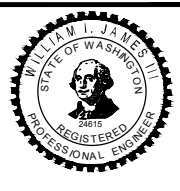

HNTB **H J H**
 FINAL DESIGN PARTNERS.
 SUBMITTED BY: DATE: REVIEWED BY: DATE:

SOUNDTRANSIT
 SCALE: 1" = 40'
 FILENAME: E335-L86-TNP104
 CONTRACT No.: RTA/LR XXXX-XX
 DATE: 12/20/2013

EAST LINK EXTENSION
CONTRACT E335
 DOWNTOWN BELLEVUE TO SPRING DISTRICT
 TRAFFIC OPERATIONAL SIGNAGE

DRAWING No.: **L86-TNP104**
 LOCATION ID:
 SHEET No.: REV: 0

XREF LIST:
 XE330-E15-SFP400
 XE335-E19-APP100
 XE335-E19-SFP100
 XE335-E19-SGP100
 XE335-L86-CAP100
 XE335-L86-CMP100
 XE335-L86-KAP100
 XE335-L86-SFP100
 XE335-L86-UCP100
 XE335-L86-CRP100
 XEL-0525x
 XEL-0525f
 XEL-0528x
 XEL-0528f
 XEL-0528u
 XE330-L85-KAP100
 XE335-GB-TB22x34
 XE335-E11-APP100
 XE335-L86-CRP100
 XE335-L86-CRP100
 XEL-0228x
 XEL-0228f
 XEL-0228u
 XEL-0531x
 XEL-0531f
 XEL-0531u
 XE335-L86-TNP101
 XE330-T86-STP001
 XE330-T86-STP002
 GB-SEAL-WU24615

ORIGINATED BY: / DATE: /
 CHECKED BY: / DATE: /
 BACK-CHECKED BY: / DATE: /
 11/20/13 11:17 AM | CALDWELL
 C:\USERS\PUBLIC\DOCUMENTS\CALDWELL\HNTB\SHAREPOINT_SOUNDTRANSIT\ORG\443\SITES\CAD\ELBEL\RED\E335DRAWINGS\E335-L86-TNP105.DWG

SEE DWG L86-TNP104

405 NORTHBOUND

SEE DWG L86-TNP106

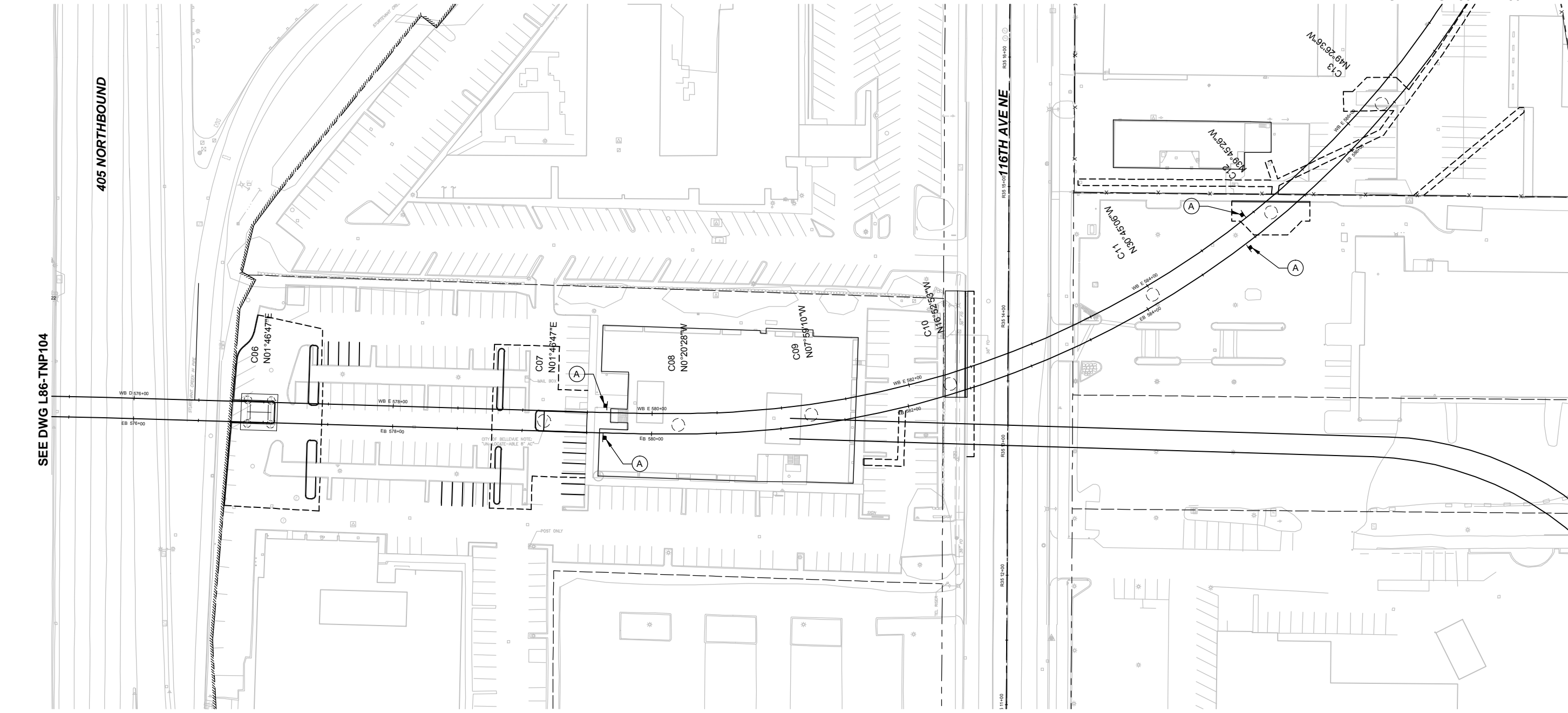

- NOTES:**
- REFER TO SHEETS L86-TND001, L86-TND002, AND L86-TND003 FOR OPERATIONAL SIGNAGE DETAILS.
 - REFER TO SHEET L86-TNS001 FOR OPERATIONAL SIGNAGE SCHEDULE.

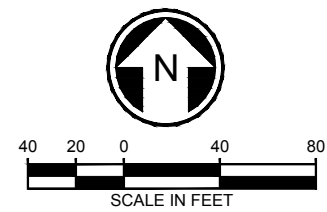

60% SUBMITTAL

DESIGNED BY:
L. BARTA
 DRAWN BY:
R. JOHNSON
 CHECKED BY:
B. JAMES
 APPROVED BY:
J. SCHUTT



LINE IS 1" AT FULL SCALE



SCALE:
1" = 40'
 FILENAME:
E335-L86-TNP105
 CONTRACT No.:
RTA/LR XXXX-XX
 DATE:
12/20/2013

**EAST LINK EXTENSION
 CONTRACT E335**
 DOWNTOWN BELLEVUE TO SPRING DISTRICT
 TRAFFIC
 OPERATIONAL SIGNAGE

DRAWING No.:
L86-TNP105
 LOCATION ID:
 SHEET No.: REV:
0

No.	DATE	DSN	CHK	APP	REVISION

XREF LIST:
 XE330-E15-SFP400
 XE335-E19-APP100
 XE335-E19-SFP100
 XE335-E19-SGP100
 XE335-L86-CAP100
 XE335-L86-CMP100
 XE335-L86-KAP100
 XE335-L86-SFP100
 XE335-L86-UCP100
 XE335-L86-CDP100
 XEL-0525x
 XEL-0525f
 XEL-0525t
 XEL-0528x
 XEL-0528f
 XEL-0528t
 XE330-L86-KAP100
 XE335-GB-TB22x34
 XE335-E11-APP100
 XE335-L86-CRP100
 XE335-L86-CRP100
 XEL-0228x
 XEL-0228f
 XEL-0228t
 XEL-0531x
 XEL-0531f
 XEL-0531t
 XE335-L86-TNP101
 XE330-T86-STP001
 XE330-T86-STP002
 GB-SEAL-WU24615

ORIGINATED BY: / DATE: /
 CHECKED BY: / DATE: /
 BACK-CHECKED BY: / DATE: /
 11/20/13 11:17 AM | CALDWELL
 C:\USERS\PUBLIC\DOCUMENTS\CALDWELL\HTTTPS\SHAREPOINT\SOUNDTRANSIT\ORG\443\SITES\CAD\EL\BEL\RED\E335\DRAWINGS\E335-L86-TNP106.DWG

SEE DWG L86-TNP105

SEE DWG L86-TNP107

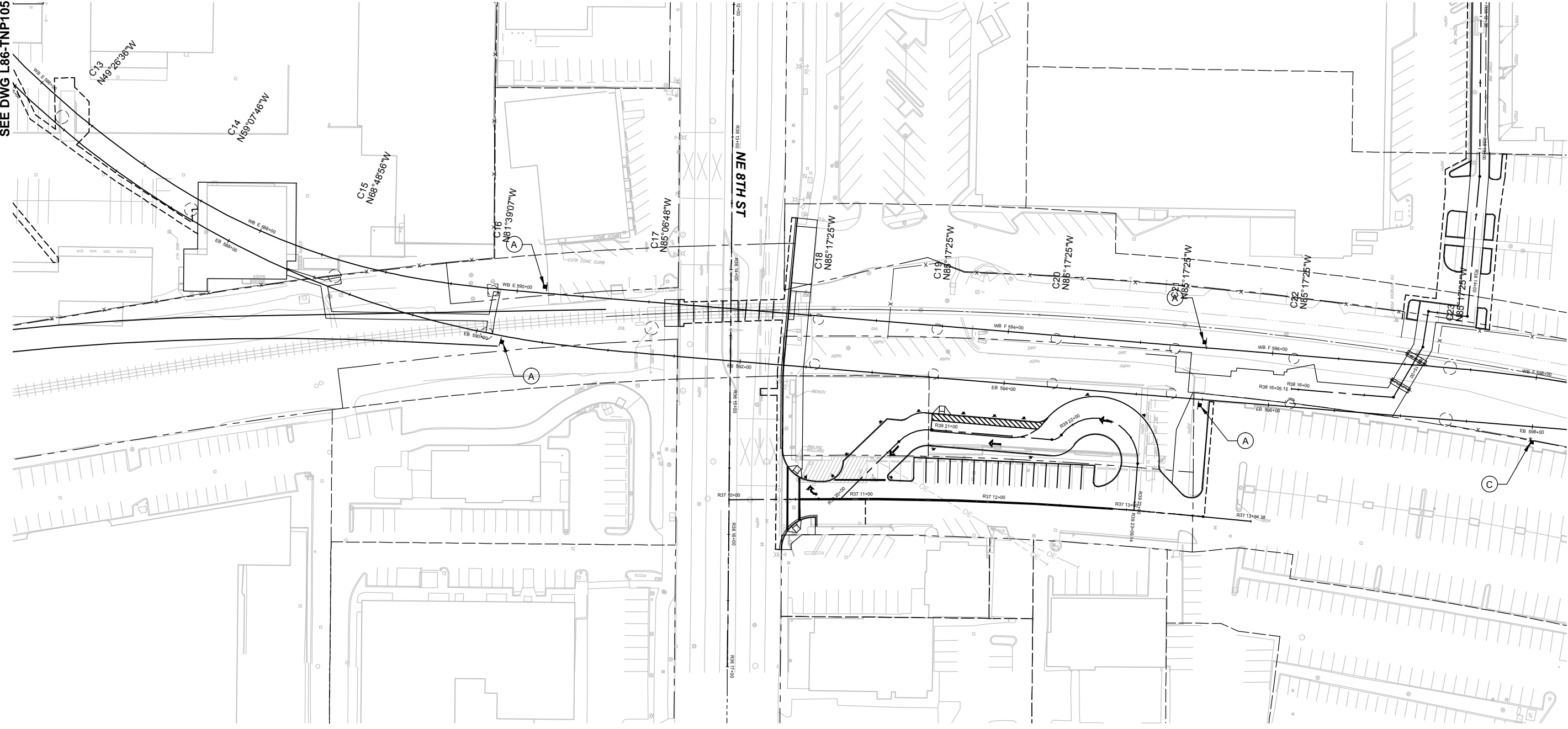

- NOTES:**
- REFER TO SHEETS L86-TND001, L86-TND002, AND L86-TND003 FOR OPERATIONAL SIGNAGE DETAILS.
 - REFER TO SHEET L86-TNS001 FOR OPERATIONAL SIGNAGE SCHEDULE.

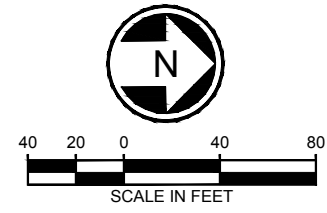

60% SUBMITTAL

DESIGNED BY:
L. BARTA
 DRAWN BY:
R. JOHNSON
 CHECKED BY:
B. JAMES
 APPROVED BY:
J. SCHUTT



LINE IS 1" AT FULL SCALE



SCALE:
1" = 40'
 FILENAME:
E335-L86-TNP106
 CONTRACT No.:
RTA/LR XXXX-XX
 DATE:
12/20/2013

**EAST LINK EXTENSION
 CONTRACT E335**
 DOWNTOWN BELLEVUE TO SPRING DISTRICT
 TRAFFIC
 OPERATIONAL SIGNAGE

DRAWING No.:
L86-TNP106
 LOCATION ID:
 SHEET No.: REV:
0

No.	DATE	DSN	CHK	APP	REVISION

XREF LIST:
 XE330-E15-SFP400
 XE335-E19-APP100
 XE335-E19-SFP100
 XE335-E19-SGP100
 XE335-L86-CAP100
 XE335-L86-CMP100
 XE335-L86-KAP100
 XE335-L86-SFP100
 XE335-L86-UCP100
 XE335-L86-CDP100
 XEL-0525rx
 XEL-0525sf
 XEL-0525st
 XEL-0528rx
 XEL-0528sf
 XEL-0528st
 XE330-L85-KAP100
 XE335-GB-TB22x34
 XE335-E11-APP100
 XE335-L86-CRP100
 XE335-L86-CRP100
 XEL-0228rx
 XEL-0228sf
 XEL-0228st
 XEL-0531rx
 XEL-0531sf
 XEL-0531st
 XE335-L86-TNP101
 XE330-T86-STP001
 XE330-T86-STP002
 GB-SEAL-WU24615

ORIGINATED BY: / DATE: /
 CHECKED BY: / DATE: /
 BACK-CHECKED BY: / DATE: /
 11/20/13 11:18 AM | CALDWELL
 C:\USERS\PUBLIC\DOCUMENTS\CALDWELL\HNTB\SHARPOINT\SOUNDTRANSIT\ORG\443\SITES\CAD\ELBEL\RED\E335\L86-TNP107.DWG

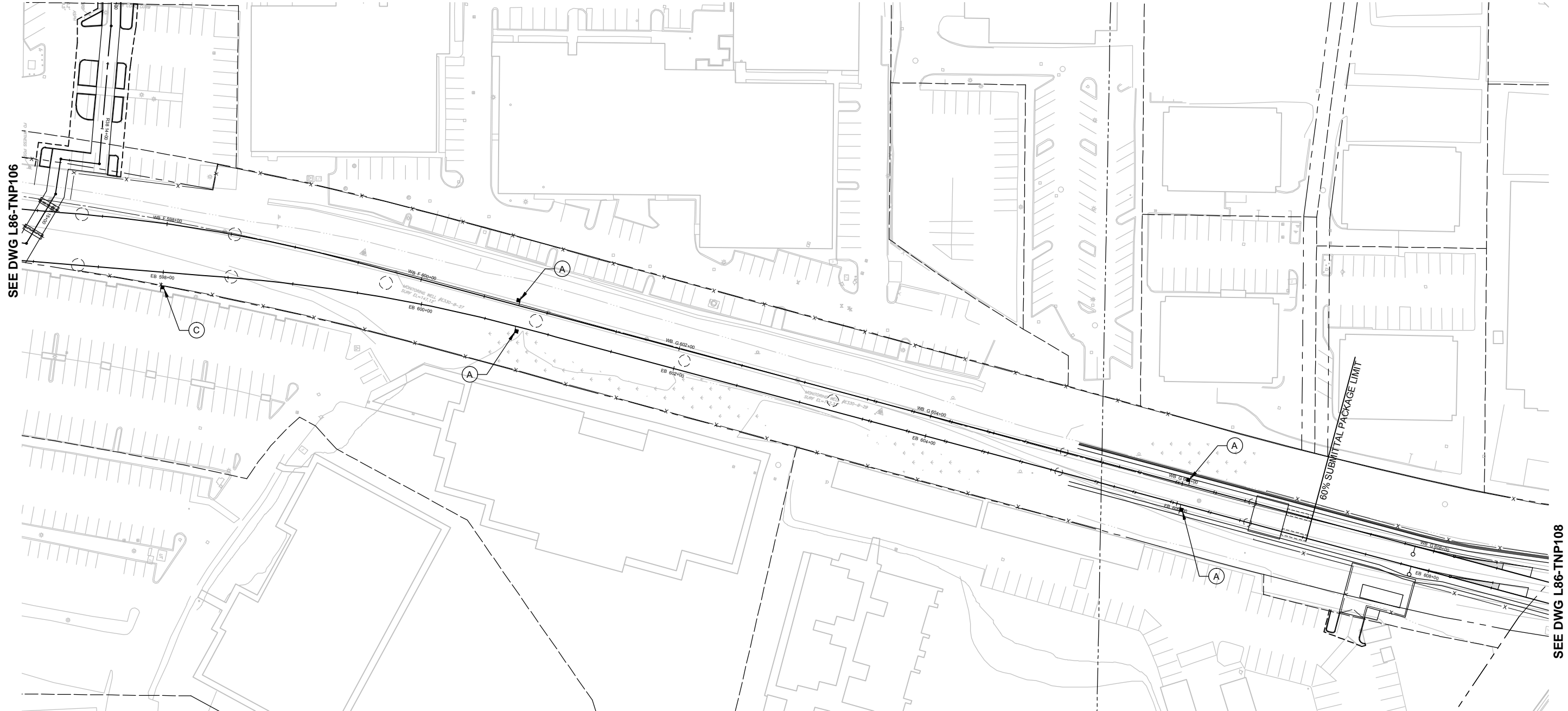

- NOTES:**
- REFER TO SHEETS L86-TND001, L86-TND002, AND L86-TND003 FOR OPERATIONAL SIGNAGE DETAILS.
 - REFER TO SHEET L86-TNS001 FOR OPERATIONAL SIGNAGE SCHEDULE.

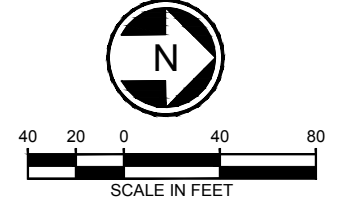

60% SUBMITTAL

DESIGNED BY:
L. BARTA
 DRAWN BY:
R. JOHNSON
 CHECKED BY:
B. JAMES
 APPROVED BY:
J. SCHUTT



LINE IS 1" AT FULL SCALE



SCALE:
1" = 40'
 FILENAME:
E335-L86-TNP107
 CONTRACT No.:
RTA/LR XXXX-XX
 DATE:
12/20/2013

**EAST LINK EXTENSION
 CONTRACT E335**
 DOWNTOWN BELLEVUE TO SPRING DISTRICT
 TRAFFIC
 OPERATIONAL SIGNAGE

DRAWING No.:
L86-TNP107
 LOCATION ID:
 SHEET No.: REV:
0

XREF LIST:
 XE330-E15-SFP400
 XE335-E19-APP100
 XE335-E19-SFP100
 XE335-E19-SGP100
 XE335-L86-CAP100
 XE335-L86-CRP100
 XE335-L86-KAP100
 XE335-L86-SFP100
 XE335-L86-UCP100
 XE335-L86-CDP100
 XEL-0525rx
 XEL-0525sf
 XEL-0525sf
 XEL-0528rx
 XEL-0528sf
 XEL-0528sf
 XE330-L86-KAP100
 XE335-GB-TB22x34
 XE335-E11-APP100
 XE335-L86-CRP100
 XE335-L86-CRP100
 XEL-0228rx
 XEL-0228sf
 XEL-0228sf
 XEL-0228sf
 XEL-0531rx
 XEL-0531sf
 XEL-0531sf
 XE335-L86-TNP101
 XE330-T86-STP001
 XE330-T86-STP002
 XEL-0831sf
 XEL-0831rx
 GB-SEAL-WU24615

ORIGINATED BY: / DATE: /
 CHECKED BY: / DATE: /
 BACK-CHECKED BY: / DATE: /
 11/20/13 11:18 AM | CALDWELL
 C:\USERS\PUBLIC\DOCUMENTS\CALDWELL\HNTB\SHAREPOINT_SOUNDTRANSIT\ORG\443\SITES\CAD\EL\BEL\RED\E335\L86-TNP108.DWG

SEE DWG L86-TNP107

SEE DWG L86-TNP109

- NOTES:**
- REFER TO SHEETS L86-TND001, L86-TND002, AND L86-TND003 FOR OPERATIONAL SIGNAGE DETAILS.
 - REFER TO SHEET L86-TNS001 FOR OPERATIONAL SIGNAGE SCHEDULE.

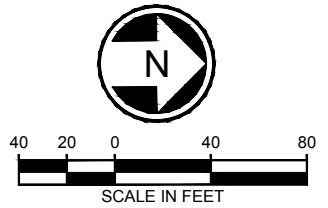

60% SUBMITTAL					
No.	DATE	DSN	CHK	APP	REVISION

DESIGNED BY:
L. BARTA
 DRAWN BY:
R. JOHNSON
 CHECKED BY:
B. JAMES
 APPROVED BY:
J. SCHUTT

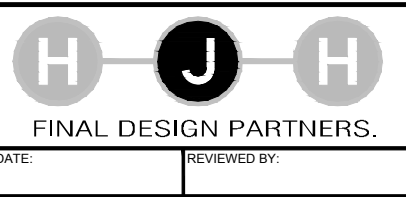
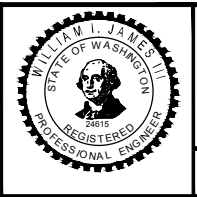

LINE IS 1" AT FULL SCALE

SOUNDTRANSIT
 SCALE: 1" = 40'
 FILENAME: E335-L86-TNP108
 CONTRACT No.: RTA/LR XXXX-XX
 DATE: 12/20/2013

EAST LINK EXTENSION CONTRACT E335
 DOWNTOWN BELLEVUE TO SPRING DISTRICT
 TRAFFIC OPERATIONAL SIGNAGE

DRAWING No.: **L86-TNP108**
 LOCATION ID:
 SHEET No.: REV: 0

XREF LIST:
 XE330-E15-SFP400
 XE335-E19-APP100
 XE335-E19-SFP100
 XE335-E19-SGP100
 XE335-L86-CAP100
 XE335-L86-CMP100
 XE335-L86-KAP100
 XE335-L86-SFP100
 XE335-L86-UCP100
 XE335-L86-CDP100
 XEL-0525rx
 XEL-0525sf
 XEL-0525sf
 XEL-0528rx
 XEL-0528sf
 XEL-0528sf
 XE330-L85-KAP100
 XE335-GB-TB22x34
 XE335-E11-APP100
 XE335-L86-CRP100
 XE335-L86-CRP100
 XEL-0228rx
 XEL-0228sf
 XEL-0228sf
 XEL-0531rx
 XEL-0531sf
 XEL-0531sf
 XE335-L86-TNP101
 XE330-T86-STP001
 XE330-T86-STP002
 XEL-0831sf
 XEL-0831rx
 GB-SEAL-WU24615

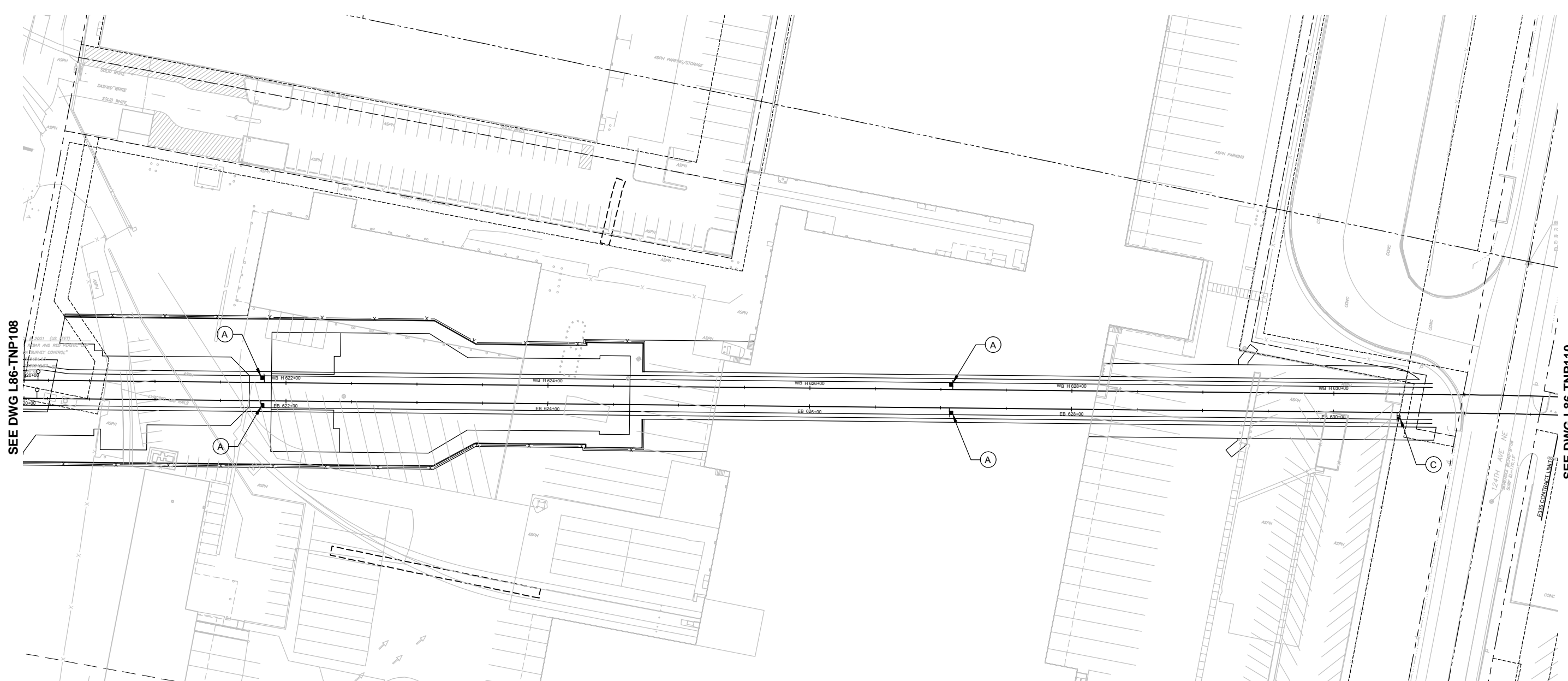

SEE DWG L86-TNP108

SEE DWG L86-TNP110

- NOTES:**
- REFER TO SHEETS L86-TND001, L86-TND002, AND L86-TND003 FOR OPERATIONAL SIGNAGE DETAILS.
 - REFER TO SHEET L86-TNS001 FOR OPERATIONAL SIGNAGE SCHEDULE.

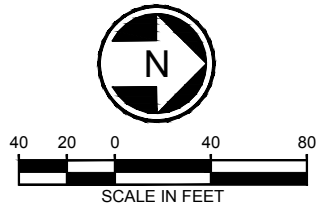

ORIGINATED BY: / DATE: /
 CHECKED BY: / DATE: /
 BACK-CHECKED BY: / DATE: /
 11/20/13 11:19 AM | CALDWELL
 C:\USERS\PUBLIC\DOCUMENTS\CALDWELL\HNTB\SHARPOINT_SOUNDTRANSIT\ORG\443\SITES\CAD\ELBEL\RED\E335\DRAWINGS\E335-L86-TNP108.DWG

60% SUBMITTAL

DESIGNED BY:
L. BARTA
 DRAWN BY:
R. JOHNSON
 CHECKED BY:
B. JAMES
 APPROVED BY:
J. SCHUTT



LINE IS 1" AT FULL SCALE



SCALE:
1" = 40'
 FILENAME:
E335-L86-TNP109
 CONTRACT No.:
RTA/LR XXXX-XX
 DATE:
12/20/2013

**EAST LINK EXTENSION
 CONTRACT E335**
 DOWNTOWN BELLEVUE TO SPRING DISTRICT
 TRAFFIC
 OPERATIONAL SIGNAGE

DRAWING No.:
L86-TNP109
 LOCATION ID:
 SHEET No.: REV:
0

No.	DATE	DSN	CHK	APP	REVISION

SUBMITTED BY: DATE: REVIEWED BY: DATE:

XREF LIST:
 XE330-E15-SFP400
 XE335-E19-APP100
 XE335-E19-SFP100
 XE335-E19-SGP100
 XE335-L86-CAP100
 XE335-L86-CMP100
 XE335-L86-KAP100
 XE335-L86-SFP100
 XE335-L86-UCP100
 XE335-L86-CRP100
 XEL-0525rx
 XEL-0525sf
 XEL-0525ut
 XEL-0528rx
 XEL-0528sf
 XEL-0528ut
 XE330-L85-KAP100
 XE335-GB-TB22x34
 XE335-E11-APP100
 XE335-L86-CRP100
 XE335-L86-CRP100
 XEL-0228rx
 XEL-0228sf
 XEL-0228ut
 XEL-0531rx
 XEL-0531sf
 XEL-0531ut
 XE335-L86-TNP101
 XE330-T86-STP001
 XE330-T86-STP002
 XEL-0831sf
 XEL-0831rx
 GB-SEAL-WU24615

ORIGINATED BY: / DATE: /
 CHECKED BY: / DATE: /
 CORRECTED BY: / DATE: /
 BACK-CHECKED BY: / DATE: /
 VERIFIED BY: / DATE: /
 11/20/13 11:19 AM | CALDWELL
 C:\USERS\PUBLIC\DOCUMENTS\CALDWELL\PROJECTS\SHARPOINT\SOUNDTRANSIT\ORG\443\SITES\CAD\ELBEL\RED\E335DRAWINGS\E335-L86-TNP110.DWG

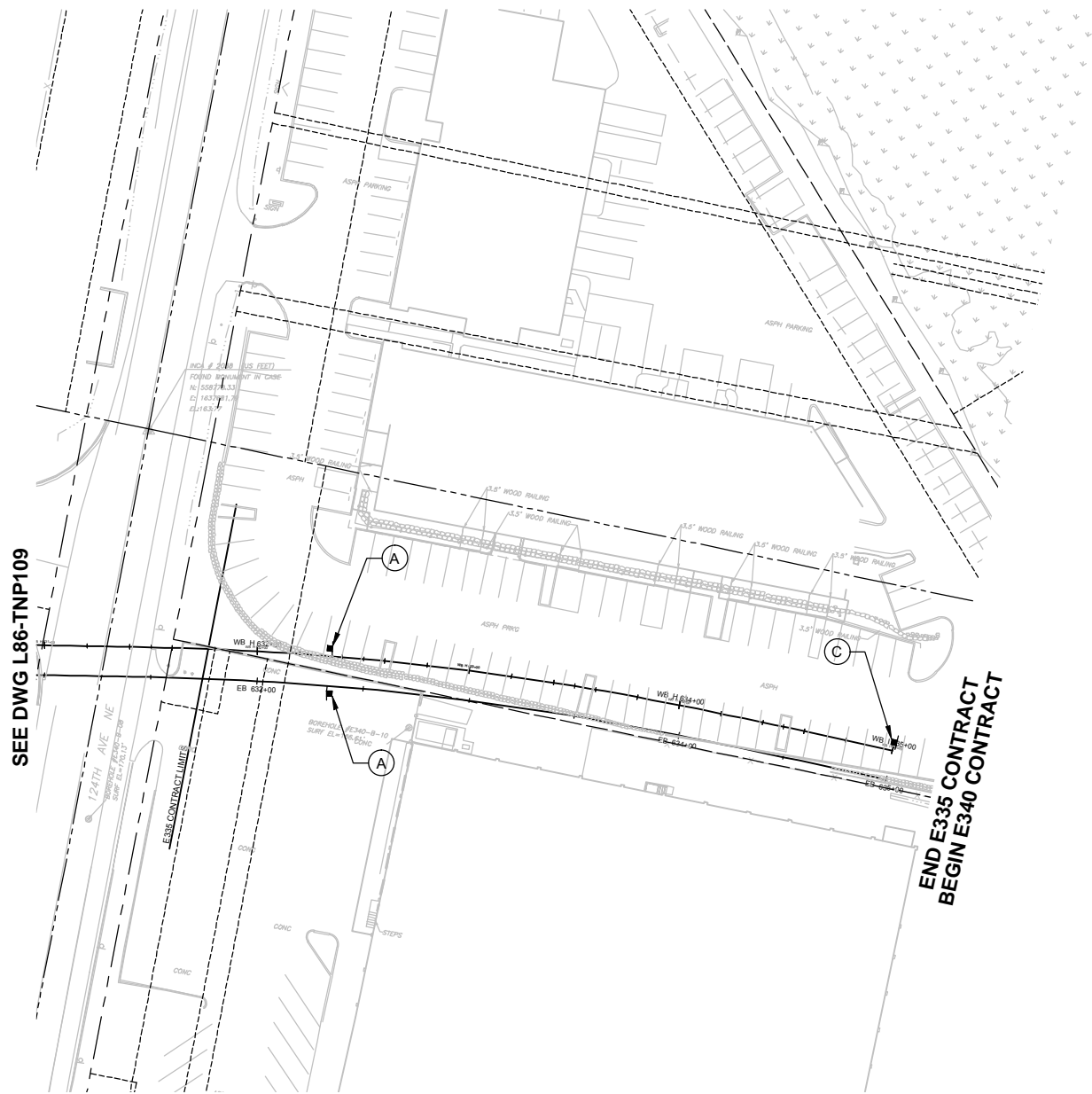

SEE DWG L86-TNP109

END E335 CONTRACT
 BEGIN E340 CONTRACT

- NOTES:**
- REFER TO SHEETS L86-TND001, L86-TND002, AND L86-TND003 FOR OPERATIONAL SIGNAGE DETAILS.
 - REFER TO SHEET L86-TNS001 FOR OPERATIONAL SIGNAGE SCHEDULE.

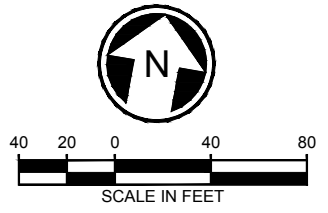

60% SUBMITTAL

DESIGNED BY:
L. BARTA
 DRAWN BY:
R. JOHNSON
 CHECKED BY:
B. JAMES
 APPROVED BY:
J. SCHUTT



LINE IS 1" AT FULL SCALE



SCALE:
1" = 40'
 FILENAME:
E335-L86-TNP110
 CONTRACT No.:
RTA/LR XXXX-XX
 DATE:
12/20/2013

**EAST LINK EXTENSION
 CONTRACT E335**
 DOWNTOWN BELLEVUE TO SPRING DISTRICT
 TRAFFIC
 OPERATIONAL SIGNAGE

DRAWING No.:
L86-TNP110
 LOCATION ID:
 SHEET No.: REV:
0

VEHICLE SIGNAL HEADS

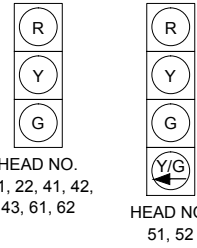

PEDESTRIAN SIGNAL HEADS



PEDESTRIAN HEAD NO.
68, 69, 88, 89

SIGNAL PHASES

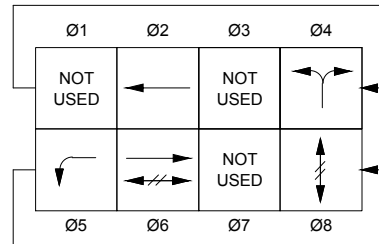

PRE-EMPTION SCHEDULE	
EVP	PHASE(S)
A	6
C	2 & 5
D	4

CONSTRUCTION NOTES:

- 1 INSTALL TYPE III SIGNAL STANDARD WITH 30.0 FOOT MAST ARM PER DETAIL SHEET L86-TSD100. INSTALL TWO VEHICLE HEADS, ONE OPTICOM SENSOR, ONE TERMINAL CABINET, ONE PED HEAD, AND ONE LED LUMINAIRE.
- 1A INSTALL PEDESTRIAN PUSH BUTTON POST PER WSDOT STANDARD PLAN J-20.10-02 AND DETAIL SHEET L86-TSD100. INSTALL ONE PUSH BUTTON.
- 2 INSTALL TYPE I SIGNAL STANDARD PER WSDOT STANDARD PLAN J-21.15-01 AND DETAIL SHEET L86-TSD100. INSTALL ONE VEHICLE HEAD, TWO PED HEADS, AND TWO PUSH BUTTONS.
- 3 INSTALL TYPE III SIGNAL STANDARD WITH 35.0 FOOT AND 40.0 FOOT MAST ARMS PER DETAIL SHEET L86-TSD100. INSTALL SIX VEHICLE HEADS, TWO OPTICOM SENSORS, ONE TERMINAL CABINET, ONE PED HEAD, ONE PUSH BUTTON, AND TWO LED LUMINAIRES.
- 4 INSTALL VEHICLE DETECTION LOOP PER CITY OF BELLEVUE STANDARD DRAWING TSSL-12 AND TSSL-13, 17 LOCATIONS.
- 5 INSTALL SIGNAL CABINET FOUNDATION PER CITY OF BELLEVUE STANDARD DRAWING TSSL-19. SIGNAL CABINET SHALL BE A TYPE-P SERIES WITH A SIEMENS M50 CONTROLLER. REFER TO ILLUMINATION PLANS FOR POWER PROVISIONS. FOR CONTINUATION OF CIRCUITS, SEE DWG L86-CLP100.
- 6 INSTALL CONDUIT WITH SPARE AND ASSOCIATED JUNCTION BOX FOR TRAFFIC SIGNAL INTERCONNECT.

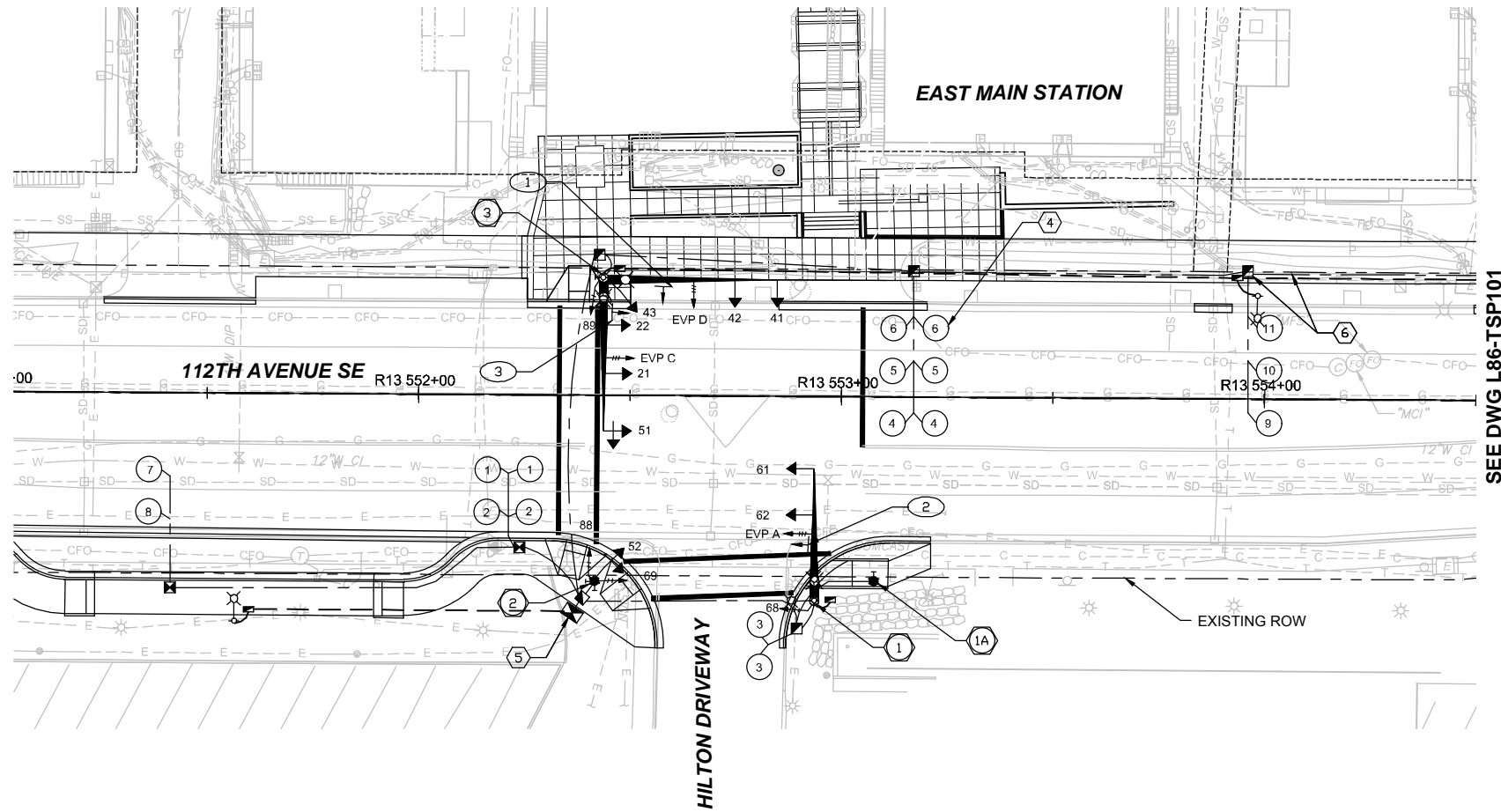

SEE DWG L86-TSP101

SIGN DETAILS

SIGN MAST ARM SCHEDULE			
SIGN NO.	DESIGNATION*	SIGN SIZE	REMARKS
1	D3-1	VAR. X 18"	STREET NAME DESIGNATION SIGN. SEE CITY OF BELLEVUE STANDARD DRAWING TE-24 (TYPE 3A).
2	D3-1	VAR. X 18"	STREET NAME DESIGNATION SIGN. SEE CITY OF BELLEVUE STANDARD DRAWING TE-24 (TYPE 3B).
3	D3-1	VAR. X 18"	STREET NAME DESIGNATION SIGN. SEE CITY OF BELLEVUE STANDARD DRAWING TE-24 (TYPE 3B).

*ALL SIGN DESIGNATION CODES ARE IN ACCORDANCE TO MUTCD STANDARDS UNLESS OTHERWISE STATED.

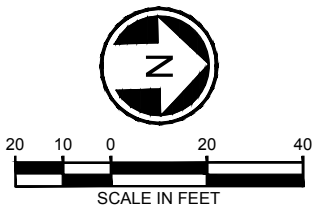

XREF LIST:
 GB-SEAL-EJ448119
 GB-Logo-JACOBS
 XE335-GB-TB22x34
 XE335-L86-CAP100
 XE320-L85-CAP100
 XE335-L86-TSP100
 XE335-L86-CRP100
 XE335-L86-CMP100
 XEL-0525x
 XEL-0525sf
 XE335-L86-UCP100
 XE335-L86-CLP100
 XE335-E11-APP100
 XE335-E11-AFP100
 XE335-E11-LPP100
 XE335-E11-LSP100
 XE320-L85-CMP100
 XE320-L85-CRP100
 XEL-0525x
 XE320-L85-SFP100

ORIGINATED BY: / DATE: /
 CORRECTED BY: / DATE: /
 CHECKED BY: / DATE: /
 VERIFIED BY: / DATE: /
 BACK-CHECKED BY: / DATE: /
 11/21/13 1:24 PM | CALDWELL
 C:\USERS\PUBLIC\DOCUMENTS\CALDWELL\PROJECTS\SHARPOINT\SOUNDTRANSIT\ORG\443\SITES\CAD\EL\BEL\RED\E335\DRAWINGS\E335-L86-TSP100.DWG

60% SUBMITTAL

DESIGNED BY:
A. BARAKOVIC
 DRAWN BY:
A. BARAKOVIC
 CHECKED BY:
S. KRISHNAN
 APPROVED BY:
J. SCHUTT

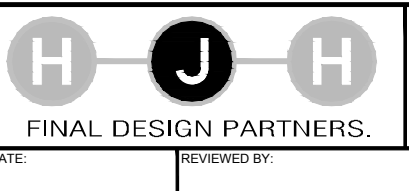

SCALE:
1" = 20'
 FILENAME:
E335-L86-TSP100
 CONTRACT No.:
RTA/LR XXXX-XX
 DATE:
12/20/2013

**EAST LINK EXTENSION
 CONTRACT E335**
 DOWNTOWN BELLEVUE TO SPRING DISTRICT
**TRAFFIC
 SIGNALIZATION**
 112TH AVE SE / HILTON DRIVEWAY

DRAWING No.:
L86-TSP100
 LOCATION ID:
 SHEET No.: REV:
 0

XREF LIST:
 GB-SEAL-EJ448119
 GB-Logo-JACOBS
 XE335-GB-TB2x34
 XE335-L86-TSP100
 XE335-L86-CRP100
 XE335-L86-CMP100
 XEL-0525ut
 XEL-0525sf
 XE335-L86-UCP100
 XE335-L86-CLP100
 XEL-0528sf
 XEL-0528ut
 XE335-L86-CAP100
 XE335-E11-LPP100
 XE335-E11-LSP100
 XEL-0529x
 XEL-0529y

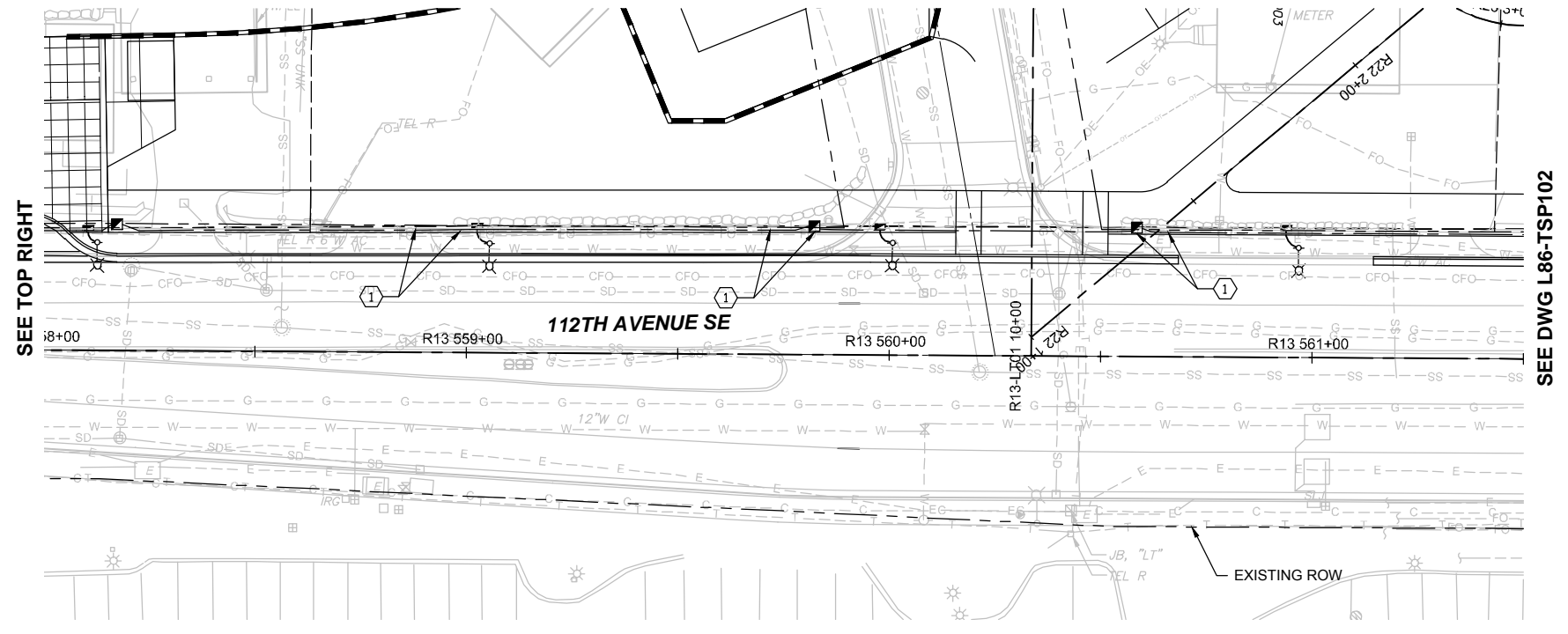
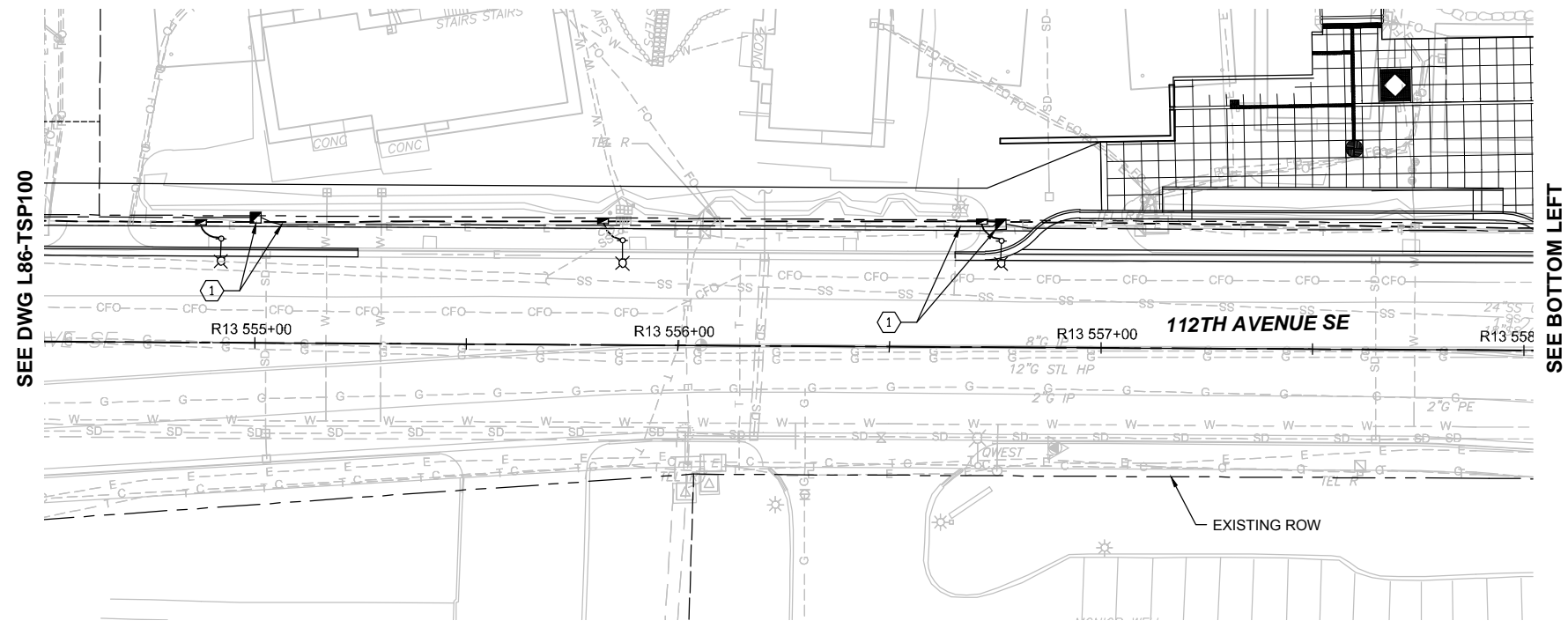

CONSTRUCTION NOTES:
 ① INSTALL CONDUIT WITH SPARE AND ASSOCIATED JUNCTION BOX FOR TRAFFIC SIGNAL INTERCONNECT.

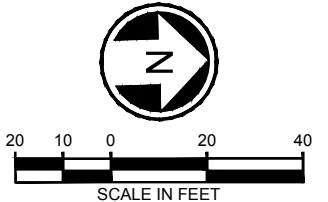

ORIGINATED BY: / DATE: /
 CHECKED BY: / DATE: /
 BACK-CHECKED BY: / DATE: /
 11/21/13 1:25 PM | CALDWELL
 C:\USERS\PUBLIC\DOCUMENTS\CALDWELL\HITPS\SHAREPOINT_SOUNDTRANSIT\ORG\443\SITES\CAD\ELBEL\RED\E335\DRAWINGS\E335-L86-TSP101.DWG

60% SUBMITTAL

DESIGNED BY:
A. BARAKOVIC
 DRAWN BY:
A. BARAKOVIC
 CHECKED BY:
S. KRISHNAN
 APPROVED BY:
J. SCHUTT

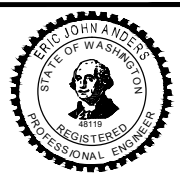

SCALE:
1" = 20'
 FILENAME:
E335-L86-TSP101
 CONTRACT No.:
RTA/LR XXXX-XX
 DATE:
12/20/2013

**EAST LINK EXTENSION
 CONTRACT E335**
 DOWNTOWN BELLEVUE TO SPRING DISTRICT
 TRAFFIC
 SIGNALIZATION - INTERCONNECT
 112TH AVE SE

DRAWING No.:
L86-TSP101
 LOCATION ID:
 SHEET No.: REV:
0

No.	DATE	DSN	CHK	APP	REVISION

EXISTING SIGNAL PHASES

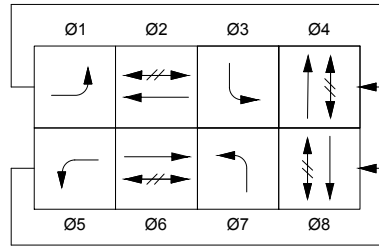

PRE-EMPTION SCHEDULE	
EVP	PHASE(S)
A	4 & 7
B	1 & 6
C	3 & 8
D	2 & 5

VEHICLE SIGNAL HEADS

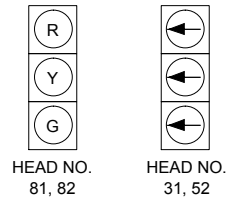

PEDESTRIAN SIGNAL HEADS

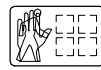

PEDESTRIAN HEAD NO.
69, 88

SIGN DETAILS

SIGN MAST ARM SCHEDULE			
SIGN NO.	DESIGNATION*	SIGN SIZE	REMARKS
1	R3-4	36" X 36"	U-TURN NOT PERMITTED SIGN.
2	D3-1	VAR. X 18"	STREET NAME DESIGNATION SIGN. SEE CITY OF BELLEVUE STANDARD DRAWING TE-24 (TYPE 3B)

*ALL SIGN DESIGNATION CODES ARE IN ACCORDANCE TO MUTCD STANDARDS UNLESS OTHERWISE STATED.

REMOVAL NOTES:

- REMOVE EXISTING SIGNAL POLE AND EQUIPMENT AFTER NEW SIGNAL IS OPERATIONAL. REMOVE FOUNDATION AND BACKFILL VOID. RETURN SIGNAL POLE AND ALL EQUIPMENT IN ITS ORIGINAL CONDITION TO CITY OF BELLEVUE EQUIPMENT MAINTENANCE YARD.

CONSTRUCTION NOTES:

- INSTALL TYPE III SIGNAL STANDARD WITH 35.0 FOOT MAST ARM PER DETAIL SHEET L86-TSD101. INSTALL THREE VEHICLE HEADS, ONE OPTICOM SENSOR, ONE TERMINAL CABINET, ONE PED HEAD, ONE PUSH BUTTON, AND ONE LED LUMINARIE.
- INSTALL TYPE I SIGNAL STANDARD PER WSDOT STANDARD PLAN J-21.15-01 AND DETAIL SHEET L86-TSD101. INSTALL ONE VEHICLE HEAD, ONE PED HEAD, AND ONE PUSH BUTTON.
- INSTALL VEHICLE DETECTION LOOP PER CITY OF BELLEVUE STANDARD DRAWING TSSL-12 AND TSSL-13, 8 LOCATIONS.

GENERAL NOTES:

PROTECT AND MAINTAIN EXISTING SIGNAL EQUIPMENT UNLESS OTHERWISE NOTED.

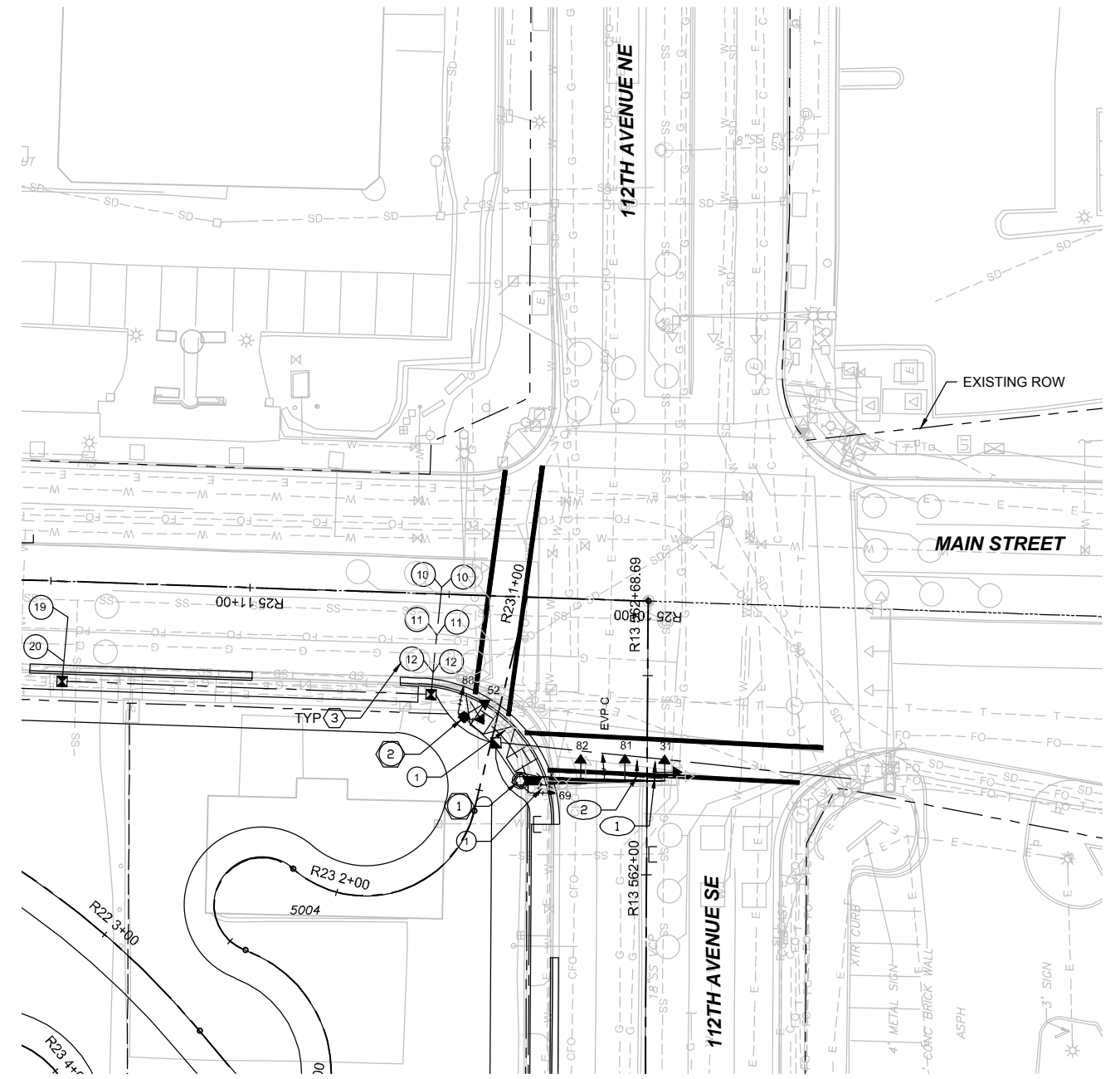

SEE DWG L86-TSP101

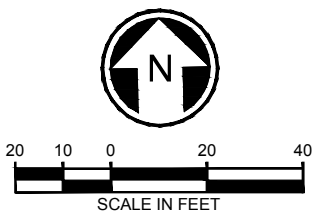

XREF LIST:
GB-Logo-JACOBS
GB-SEAL-EJ448119
xEL-0528f
xEL-0528t
xEL-0528x
xE335-L86-TSP102
xE335-L86-CAP100
xE335-L86-CPP100
xE335-L86-CMP100
xE335-L86-CRP100
xE335-L86-TSP100
xE335-L86-UCP100
xE335-L86-RPP100

ORIGINATED BY: / DATE: /
CORRECTED BY: / DATE: /
VERIFIED BY: / DATE: /
BACK-CHECKED BY: / DATE: /
11/22/13 3:50 PM | CALDWELL
C:\USERS\PUBLIC\DOCUMENTS\CALDWELL\HTTTPS\SHAREPOINT\SOUNDTRANSIT\ORG\443\SITES\CAD\EL\BEL\RED\E335\DRAWINGS\E335-L86-TSP102.DWG

60% SUBMITTAL

DESIGNED BY:
A. BARAKOVIC
DRAWN BY:
A. BARAKOVIC
CHECKED BY:
S. KRISHNAN
APPROVED BY:
J.SCHUTT

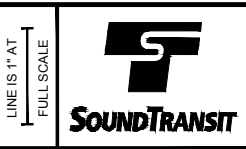
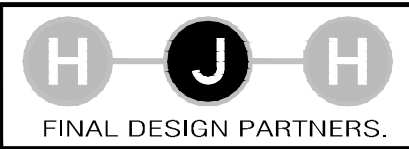

SCALE:
1" = 20'
FILENAME:
E335-L86-TSP102
CONTRACT No.:
RTA/LR XXXX-XX
DATE:
12/20/2013

**EAST LINK EXTENSION
CONTRACT E335**
DOWNTOWN BELLEVUE TO SPRING DISTRICT
TRAFFIC
SIGNALIZATION
112TH AVE SE / MAIN ST

DRAWING No.:
L86-TSP102
LOCATION ID:
SHEET No.:
REV:
0

XREF LIST:
 XE330-E15-SFP400
 XE335-E19-APP100
 XE335-E19-SFP100
 XE335-E19-SGP100
 XE335-L86-CAP100
 XE335-L86-CAP100
 XE335-L86-SFP100
 XEL-0228x
 XEL-0228f
 XEL-0228r
 XEL-0528x
 XEL-0528f
 XEL-0528r
 XE335-GB-TB22x34
 XE335-L86-RPP100
 XE335-L86-CCP100
 XE335-L86-CCP100
 XE335-L86-TSP100
 GB-SEAL-EJ448119
 XE330-T86-CCP100

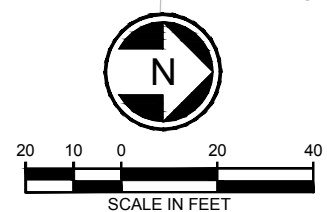
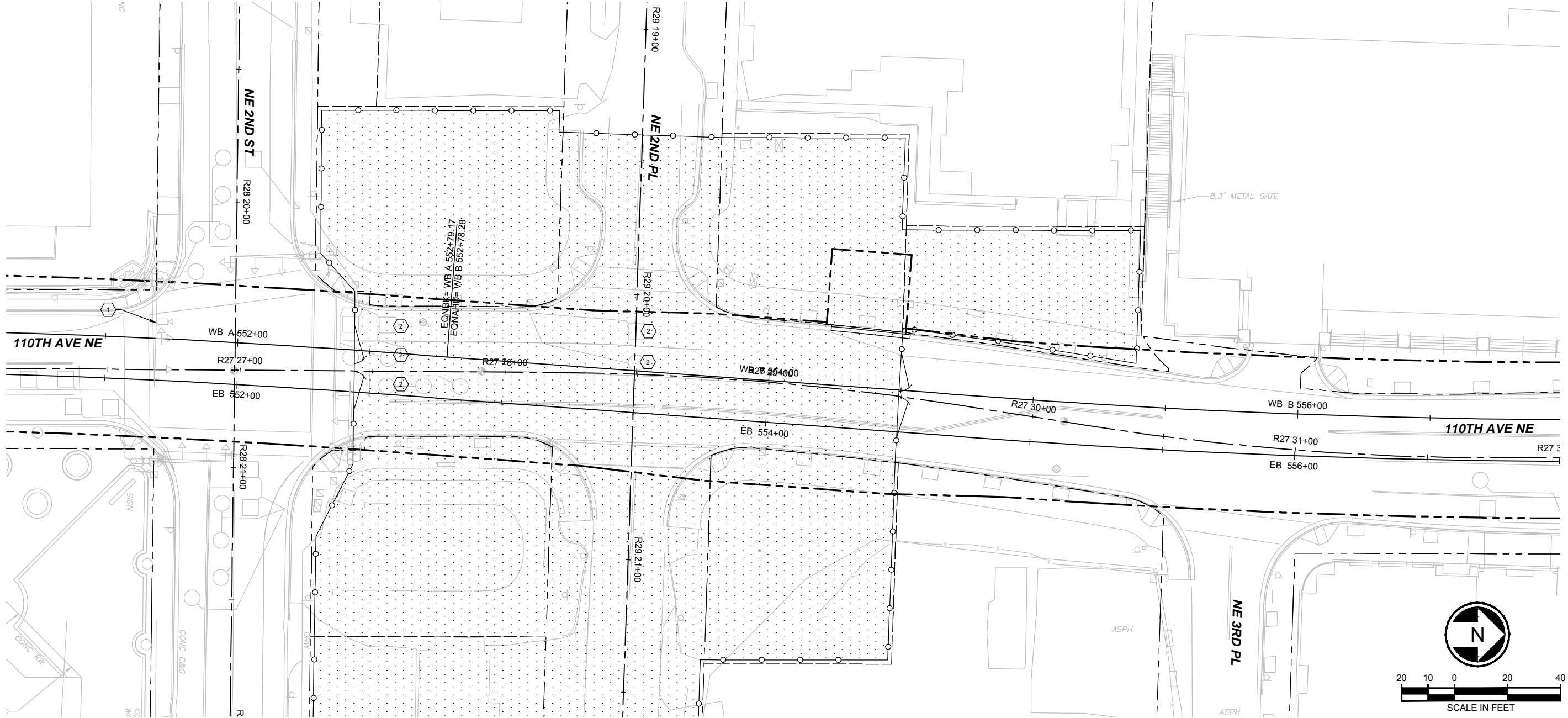

CONSTRUCTION NOTES:

- ① MAINTAIN TEMPORARY VEHICLE DETECTION CAMERA INSTALLED BY OTHERS. ADJUST CAMERA AIM AS NECESSARY FOR SOUTHBOUND CONSTRUCTION TRAFFIC EXIT STAGING AREA.
- ② COORDINATE REACTIVATION OF EXISTING SOUTHBOUND DETECTION LOOPS AT 110TH AVE NE.

GENERAL NOTES:

- 1. PROTECT AND MAINTAIN EXISTING SIGNAL EQUIPMENT UNLESS OTHERWISE NOTED.
- 2. SEE STAGING PLAN FOR STAGING AREA HATCH INFORMATION AND BOUNDARIES.

ORIGINATED BY: / DATE: /
 CHECKED BY: / DATE: /
 BACK-CHECKED BY: / DATE: /
 11/22/13 | 2:21 PM | CALDWELL
 C:\USERS\PUBLIC\DOCUMENTS\CALDWELL\HNTB\SHARPOINT\SOUNDTRANSIT\ORG\443\SITES\CAD\EL\BEL\RED\E335\DRAWINGS\E335-L86-TSP105.DWG

60% SUBMITTAL

DESIGNED BY:
E. ANDERS
 DRAWN BY:
R. JOHNSON
 CHECKED BY:
J. PRZYCHODZEN
 APPROVED BY:
J. SCHUTT

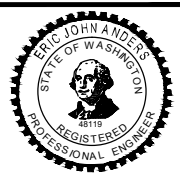

LINE IS 1" AT FULL SCALE



SCALE:
1" = 20'
 FILENAME:
E335-L86-TSP105
 CONTRACT No.:
RTA/LR XXXX-XX
 DATE:
12/20/2013

**EAST LINK EXTENSION
 CONTRACT E335**
 DOWNTOWN BELLEVUE TO SPRING DISTRICT
 TRAFFIC
 SIGNALIZATION
 110TH AVE NE / NE 2ND PL

DRAWING No.:
L86-TSP105
 LOCATION ID:
 SHEET No.: REV:
0

No.	DATE	DSN	CHK	APP	REVISION

XREF LIST:
 XE335-L86-CAP100
 XEL-0228r
 XEL-0228f
 XEL-0528r
 XEL-0528f
 XE335-GB-TB22x34
 XE335-L86-TSP100
 XE335-L86-TMP101
 XE335-L86-TMP101
 GB-SEAL-EJA48119

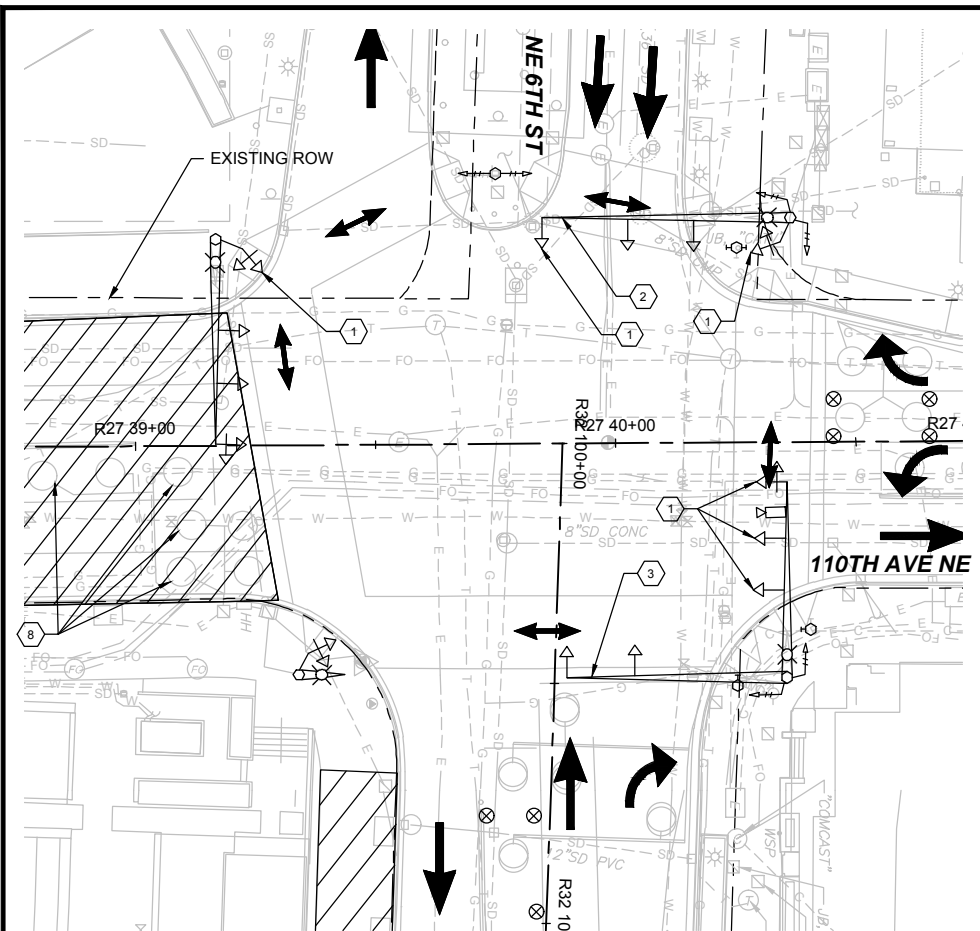

TEMPORARY SIGNALIZATION DURING
 110TH AVE NE FULL STREET CLOSURE

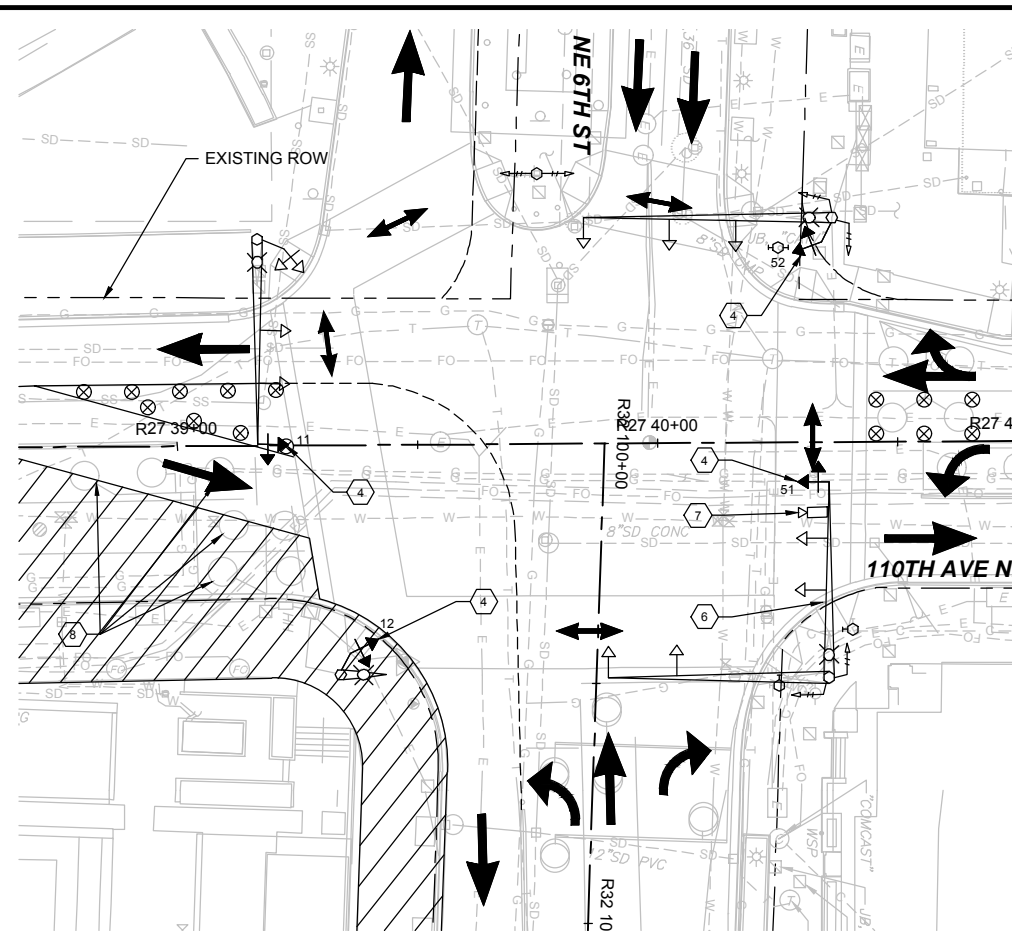
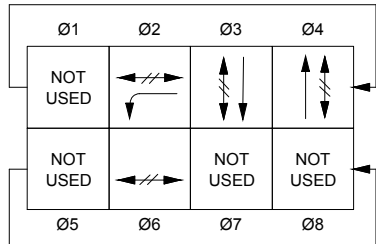

TEMPORARY SIGNALIZATION DURING
 110TH AVE NE EAST SIDE HALF STREET CLOSURE

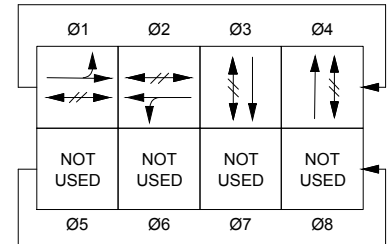

VEHICLE SIGNAL HEADS

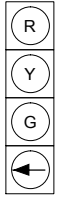

HEAD NO.
 11,12,51,52

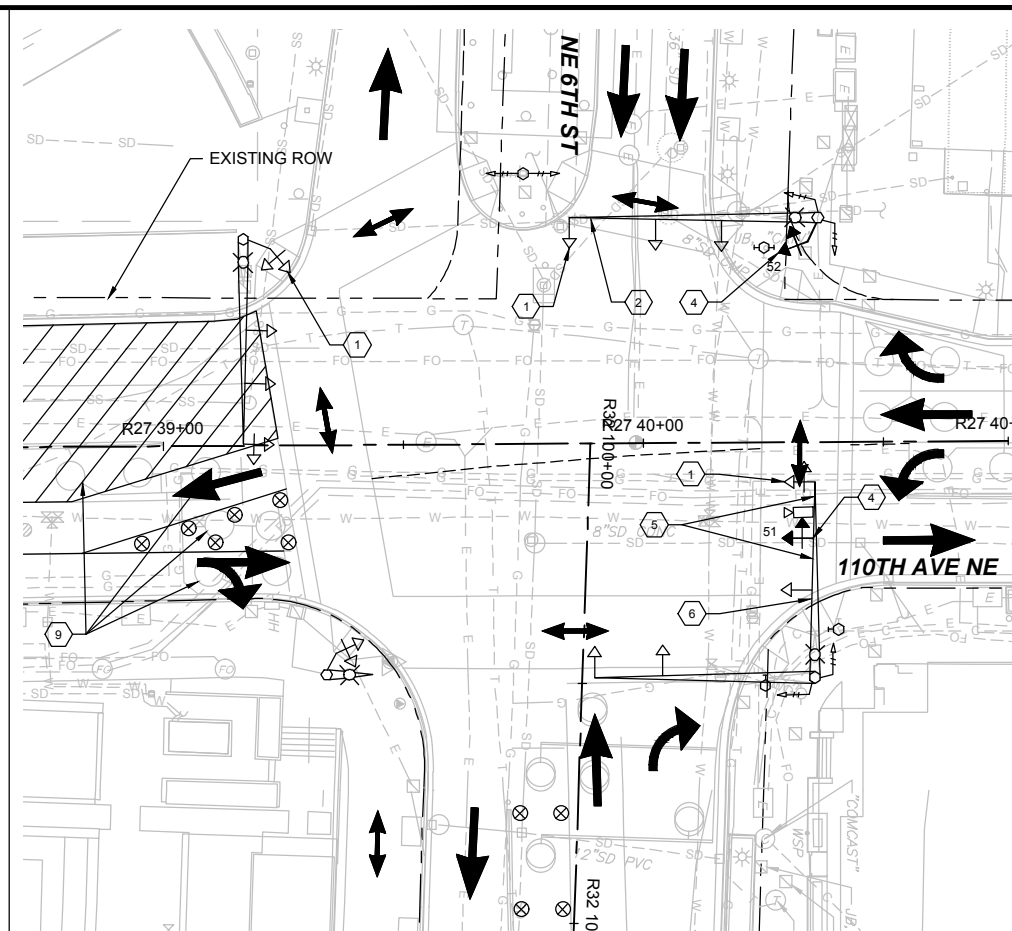

TEMPORARY SIGNALIZATION DURING
 110TH AVE NE WEST SIDE FULL STREET CLOSURE

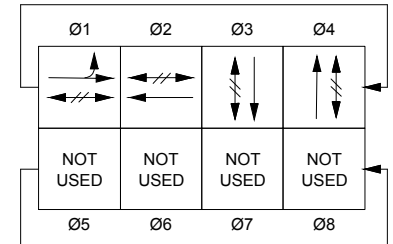

VEHICLE SIGNAL HEADS

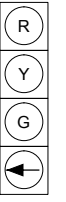

HEAD NO.
 51, 52

CONSTRUCTION NOTES:

- ① BAG EXISTING SIGNAL HEAD DISPLAY
- ② BAG EXISTING MAST ARM MOUNTED LEFT TURN ONLY SIGN.
- ③ BAG EXISTING MAST ARM MOUNTED NO LEFT TURN ON RED SIGN.
- ④ REPLACE EXISTING 3 SECTION SIGNAL HEAD WITH NEW 4 SECTION SIGNAL HEAD IDENTIFIED THIS SHEET.
- ⑤ RELOCATE EXISTING MAST ARM MOUNTED LEFT TURN TRANSIT ONLY SIGN. MOUNT EXISTING SIGN LEFT OF 4 SECTION SIGNAL HEAD.
- ⑥ BAG EXISTING MAST ARM MOUNTED RIGHT TURN ONLY SIGN.
- ⑦ INSTALL TEMPORARY VEHICLE DETECTION CAMERA TO EXISTING MAST ARM SIGNAL POLE. AIM CAMERA FOR THE NORTHBOUND 110TH AVE NE TRAFFIC.
- ⑧ DISABLE EXISTING NORTHBOUND LOOPS.
- ⑨ REACTIVATE EXISTING NORTHBOUND LOOPS.

GENERAL NOTES:

PROTECT AND MAINTAIN EXISTING SIGNAL EQUIPMENT UNLESS OTHERWISE NOTED.

ONCE CONSTRUCTION IS COMPLETE, RETURN ALL ASSOCIATED SIGNAL HEADS DISPLAYS AND MAST ARM MOUNTED SIGNS BACK TO ORIGINAL CONDITION.

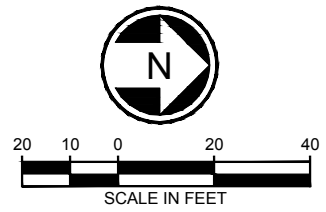

ORIGINATED BY: / DATE: /
 CHECKED BY: / DATE: /
 BACK-CHECKED BY: / DATE: /
 11/25/13 1:32:27 PM | CALDWELL
 C:\USERS\PUBLIC\DOCUMENTS\CALDWELL\HNTB\SHAREPOINT_SOUNDTRANSIT\ORG\443\SITES\CAD\BEL\RED\E335-L86-TSP106.DWG

60% SUBMITTAL

DESIGNED BY:
 E. ANDERS
 DRAWN BY:
 R. JOHNSON
 CHECKED BY:
 J. PRZYCHODZEN
 APPROVED BY:
 J. SCHUTT



LINE IS 1" AT
 FULL SCALE



SCALE:
 1" = 20'
 FILENAME:
 E335-L86-TSP106
 CONTRACT No.:
 RTA/LR XXXX-XX
 DATE:
 12/20/2013

EAST LINK EXTENSION
 CONTRACT E335
 DOWNTOWN BELLEVUE TO SPRING DISTRICT
 TRAFFIC
 TEMPORARY SIGNALIZATION
 110TH AVE NE / NE 6TH ST

DRAWING No.:
 L86-TSP106
 LOCATION ID:
 SHEET No.: REV:
 0

XREF LIST:
 XE330-E15-SFP400
 XE335-E19-APP100
 E330-E19-LP
 XE335-E19-SFP100
 XE335-E19-SGP100
 XE335-L86-CAP100
 XE335-L86-CMP100
 XE330-L86-CSP100
 XE335-L86-KAP100
 XE335-L86-LFP100
 XE335-L86-SFP100
 XE335-L86-LUCP100
 XE330-L86-RLV200
 XEL-0228x
 XEL-0228f
 XEL-0228u
 XEL-0528x
 XEL-0528f
 XEL-0528u
 XE335-GB-TB22x34
 XE335-L86-RFP100
 XE335-L86-CGP100
 XE335-L86-CPH100
 XE335-L86-CRP100
 XE335-L86-TSP100
 GB-SEAL-EJA48119

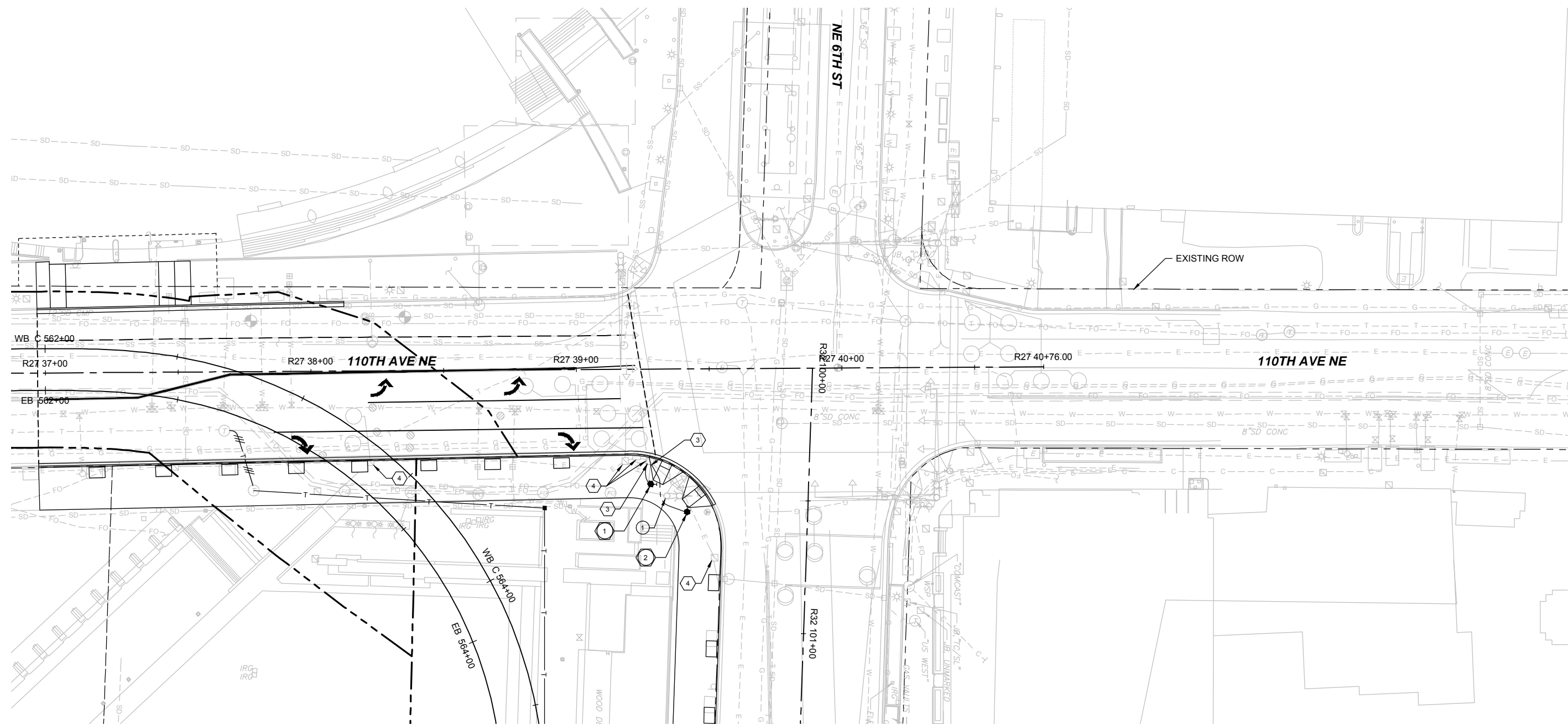

REMOVAL NOTES:

- ① REMOVE EXISTING TWO PUSH BUTTON ASSEMBLIES FROM EXISTING LUMINAIRE STANDARD.

CONSTRUCTION NOTES:

- ① ② INSTALL PEDESTRIAN PUSH BUTTON POST PER WSDOT STANDARD PLAN J-20.10-01 AND DETAIL SHEET L86-TSD101. INSTALL ONE PUSH BUTTON.
- ③ ROUTE CONDUIT AND CONNECT TO EXISTING JUNCTION BOX.
- ④ ADJUST EXISTING JUNCTION BOX TO GRADE.

SIGNAL PHASES

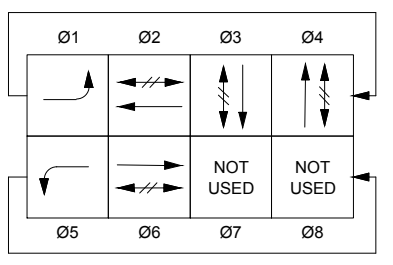

GENERAL NOTES:

PROTECT AND MAINTAIN EXISTING SIGNAL EQUIPMENT UNLESS OTHERWISE NOTED.

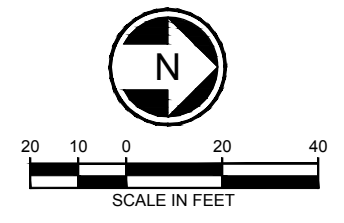

ORIGINATED BY: / DATE: /
 CHECKED BY: / DATE: /
 BACK-CHECKED BY: / DATE: /
 C:\USERS\PUBLIC\DOCUMENTS\CALDWELL\HNTB\SHAREPOINT_SOUNDTRANSIT\ORG\443\SITES\CAD\BEL\RED\E335-L86-TSP107.DWG

60% SUBMITTAL

DESIGNED BY:
E. ANDERS
 DRAWN BY:
R. JOHNSON
 CHECKED BY:
J. PRZYCHODZEN
 APPROVED BY:
J.SCHUTT

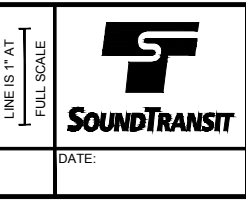
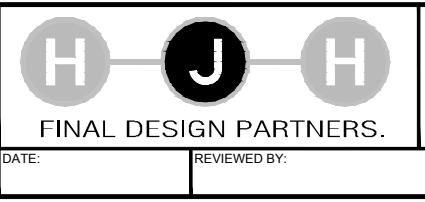
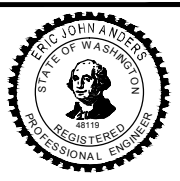

SCALE:
1" = 20'
 FILENAME:
E335-L86-TSP107
 CONTRACT No.:
RTA/LR XXXX-XX
 DATE:
12/20/2013

**EAST LINK EXTENSION
 CONTRACT E335**
 DOWNTOWN BELLEVUE TO SPRING DISTRICT
 TRAFFIC
 SIGNALIZATION
 110TH AVE NE / NE 6TH ST

DRAWING No.:
L86-TSP107
 LOCATION ID:
 SHEET No.: REV:
 0

XREF LIST:
 E330-E15-AK
 E330-E15-AR
 E330-E15-SFP400
 E335-E19-APP100
 E330-E19-LP
 E335-E19-SFP100
 E335-E19-SGP100
 E335-L86-CAP100
 E335-L86-CMP100
 E330-L86-CSP100
 E335-L86-KAP100
 E335-L86-LPP100
 E335-L86-SFP100
 E330-L86-RZV020
 XEL-0528x
 XEL-0528f
 XEL-0528t
 XE35-GB-TB22x34
 XE35-L86-RPP100
 XE35-L86-CGP100
 XE35-L86-CPP100
 XE35-L86-CRP100
 XE35-L86-TSP100
 Y:\SEAW001\EastLink_Sy...
 Y:\SEAW001\EastLink_Sy...
 Y:\SEAW001\EastLink_Sy...
 GB-SEAL-EJ445119

ORIGINATED BY: / DATE: /
 CHECKED BY: / DATE: /
 BACK-CHECKED BY: / DATE: /
 11/22/13 | 2:22 PM | CALDWELL
 C:\USERS\PUBLIC\DOCUMENTS\CALDWELL\HNTB\PROJECTS\SHARPOINT\SOUNDTRANSIT\ORG\443\SITES\CAD\EL\BEL\RED\E335-L86-TSP109.DWG

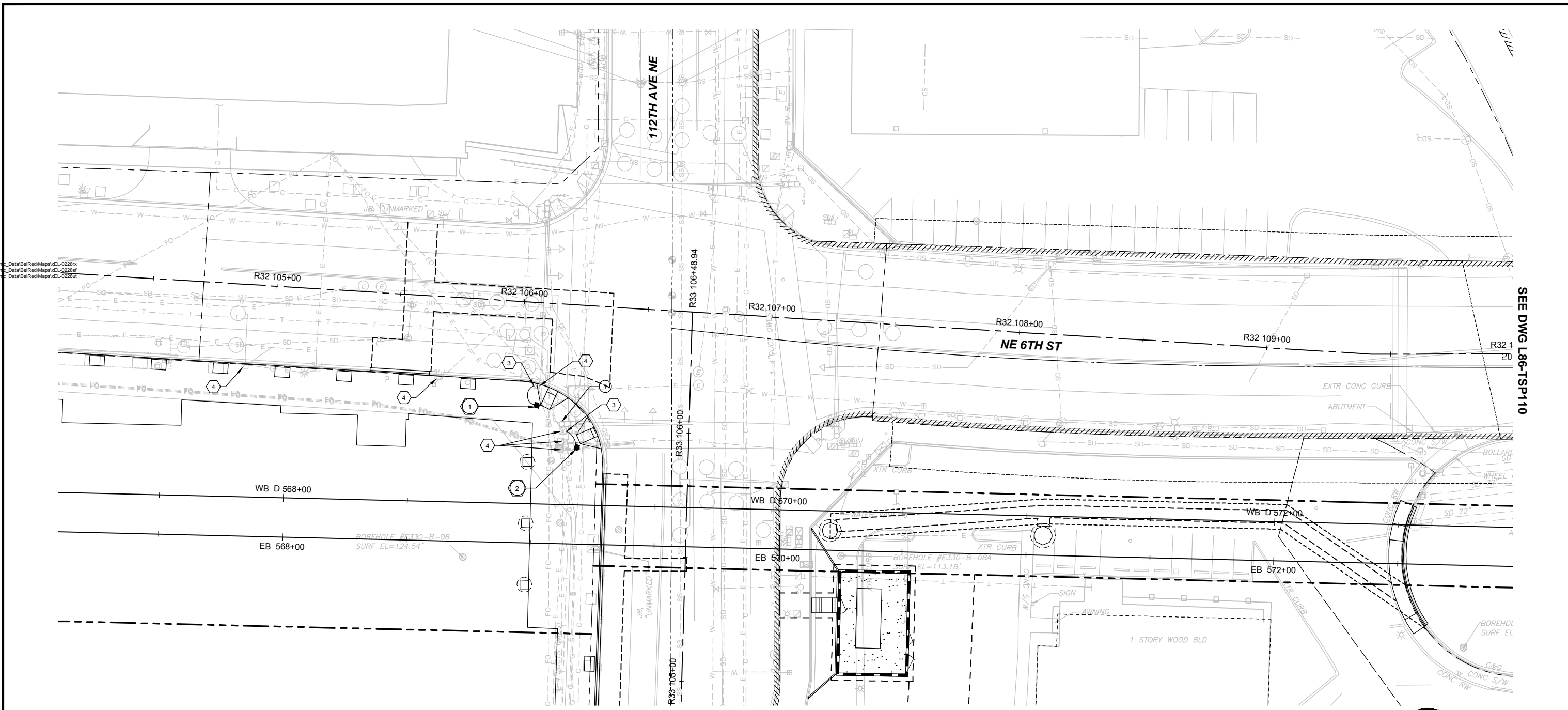

REMOVAL NOTES:
 ① REMOVE EXISTING TWO PUSH BUTTON ASSEMBLIES FROM EXISTING SIGNAL POLE STANDARD.

CONSTRUCTION NOTES:
 ① ② INSTALL PEDESTRIAN PUSH BUTTON POST PER WSDOT STANDARD PLAN J-20.10-01 AND DETAIL SHEET L86-TSD102. INSTALL ONE PUSH BUTTON.
 ③ ROUTE CONDUIT AND CONNECT TO EXISTING JUNCTION BOX.
 ④ ADJUST EXISTING JUNCTION BOX TO GRADE.

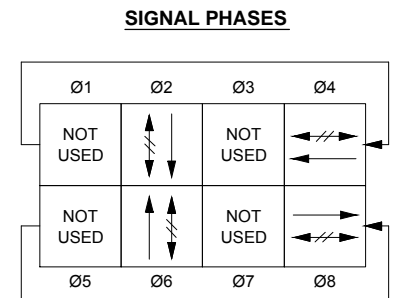

GENERAL NOTES:
 PROTECT AND MAINTAIN EXISTING SIGNAL EQUIPMENT UNLESS OTHERWISE NOTED.

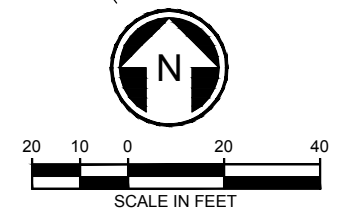

SEE DWG L86-TSP110

60% SUBMITTAL

DESIGNED BY:
E. ANDERS
 DRAWN BY:
R. JOHNSON
 CHECKED BY:
J. PRZYCHODZEN
 APPROVED BY:
J. SCHUTT

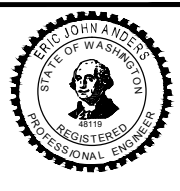

SUBMITTED BY:
DATE:
REVIEWED BY:
DATE:



SCALE:
1" = 20'
 FILENAME:
E335-L86-TSP109
 CONTRACT No.:
RTA/LR XXXX-XX
 DATE:
12/20/2013

**EAST LINK EXTENSION
 CONTRACT E335**
 DOWNTOWN BELLEVUE TO SPRING DISTRICT
 TRAFFIC
 SIGNALIZATION
 112th AVE NE / NE 6TH ST

DRAWING No.:
L86-TSP109
 LOCATION ID:
SHEET No.:
REV:
0

XREF LIST:
 XE330-E15-SFP400
 XE335-E19-APP100
 XE335-E19-SFP100
 XE335-E19-SGP100
 XE335-L86-CAP100
 XE335-L86-CMP100
 XE335-L86-KAP100
 XE335-L86-SFP100
 XEL-0528x
 XEL-0528f
 XEL-0528u
 XE335-GB-TB22x34
 XE335-L86-RFP100
 XE335-L86-CGP100
 XE335-L86-CPP100
 XE335-L86-CRP100
 XE335-L86-TSP100
 GB-SEAL-EJA48119

ORIGINATED BY: / DATE: /
 CHECKED BY: / DATE: /
 BACK-CHECKED BY: / DATE: /
 11/22/13 | 2:22 PM | CALDWELL
 C:\USERS\PUBLIC\DOCUMENTS\CALDWELL\HNTB\SHARPOINT\SOUNDTRANSIT\ORG\443\SITES\CAD\ELBEL\RED\E335-L86-TSP110.DWG

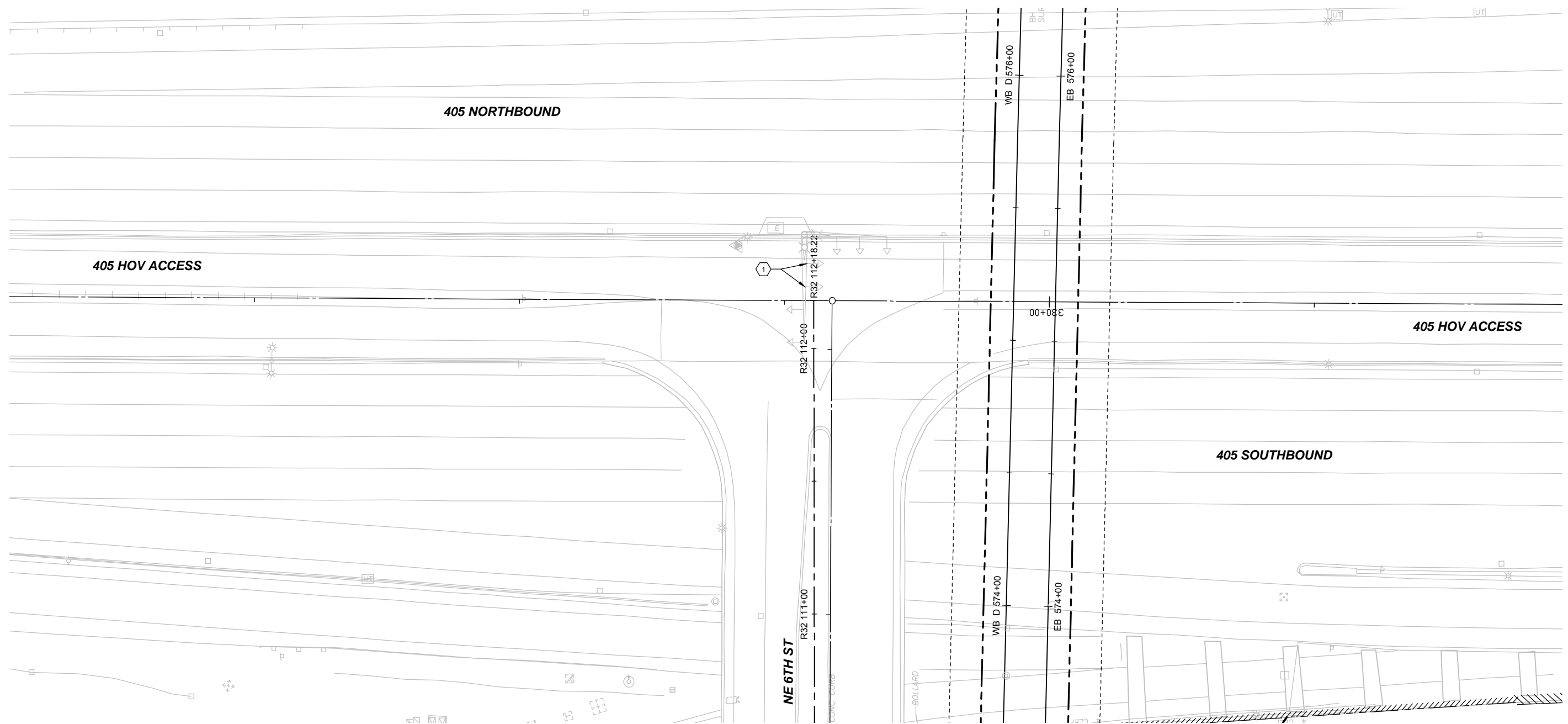

CONSTRUCTION NOTES:

- 1 LOWER 3" EXISTING TWO NORTHBOUND OFF RAMP SIGNAL HEAD DISPLAYS USING NEW L-FITTING IN ACCORDANCE WITH STANDARD PLAN J-75.20-00. REMOUNT RED DISPLAY BELOW MAST ARM.

GENERAL NOTES:

PROTECT AND MAINTAIN EXISTING SIGNAL EQUIPMENT UNLESS OTHERWISE NOTED.

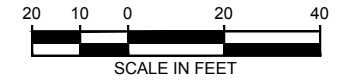

60% SUBMITTAL

DESIGNED BY:
E. ANDERS
 DRAWN BY:
R. JOHNSON
 CHECKED BY:
J. PRZYCHODZEN
 APPROVED BY:
J. SCHUTT



LINE IS 1" AT FULL SCALE



SCALE:
1" = 20'
 FILENAME:
E335-L86-TSP110
 CONTRACT No.:
RTA/LR XXXX-XX
 DATE:
12/20/2013

**EAST LINK EXTENSION
 CONTRACT E335**
 DOWNTOWN BELLEVUE TO SPRING DISTRICT
 TRAFFIC
 SIGNALIZATION
 NE 6TH ST / HOV RAMP

DRAWING No.:
L86-TSP110
 LOCATION ID:
 SHEET No.: REV:
0

XREF LIST:
 XE335-GB-TR22x34
 XE335-L86-SEP100
 XE335-L86-CAP100
 XE335-L86-CMP100
 XE335-L86-CRP100
 XE335-L86-CZV020
 XE335-L86-SFP100
 XEL-0528cn
 XEL-0528rx
 XEL-0528rf
 XEL-0528ut
 XE335-L86-LMP100
 XE335-E19-APP100
 XE335-E19-LSP100
 XEL-0531cn
 XEL-0531rx
 XEL-0531rf
 XEL-0531ut
 GB-SEAL-JWL1135
 XE335-L86-KAP100
 XE335-L86-LIP100
 XE335-L86-CDP100
 XEL-0531vg
 XE335-L86-KAP010

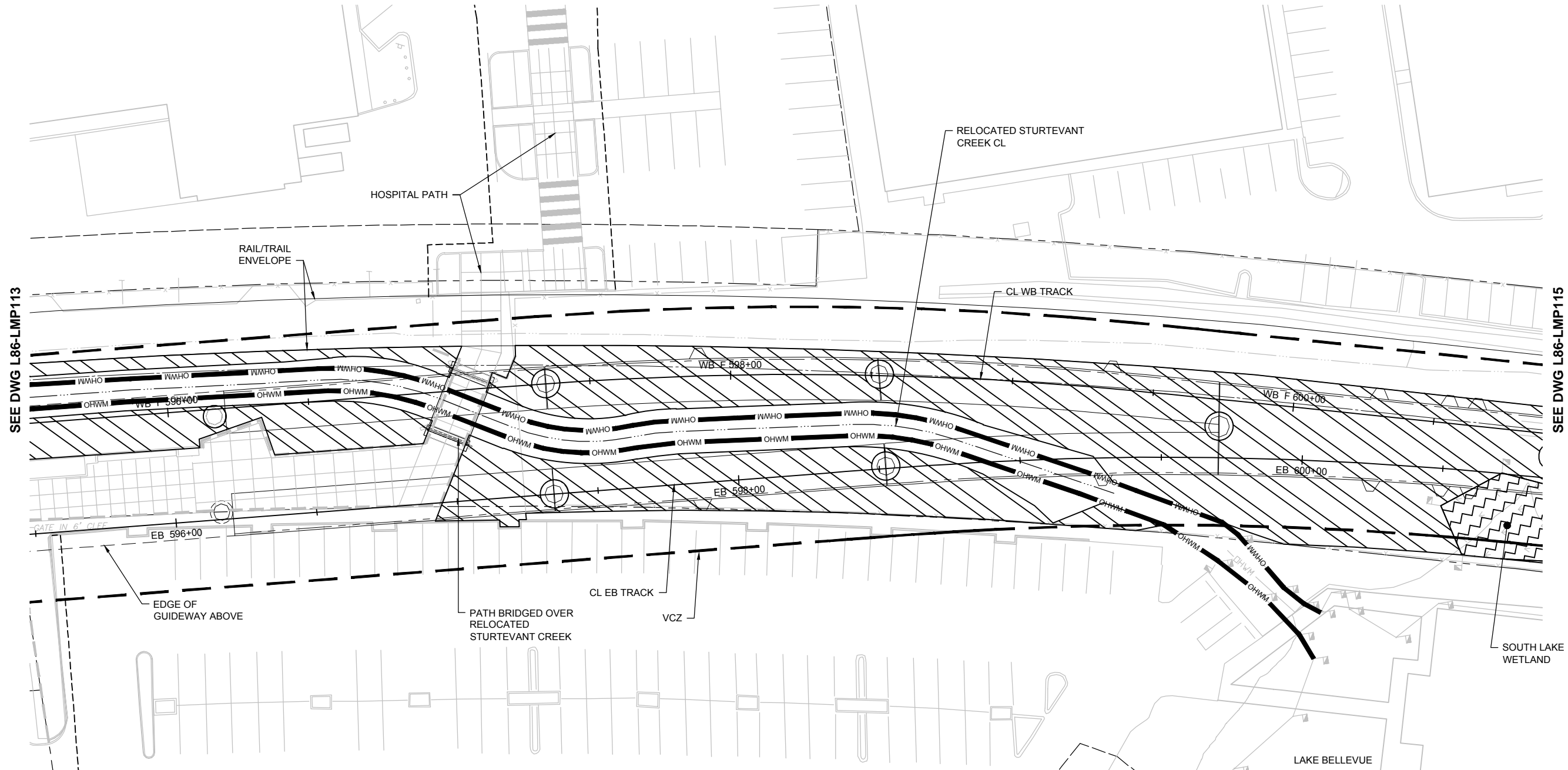

SEE DWG L86-LMP113

SEE DWG L86-LMP115

ORIGINATED BY: / DATE: /
 CORRECTED BY: / DATE: /
 CHECKED BY: / DATE: /
 BACK-CHECKED BY: / DATE: /
 VERIFIED BY: / DATE: /
 11/25/13 1:30 PM | CALDWELL
 C:\USERS\PUBLIC\DOCUMENTS\CALDWELL\HNTB\SHAREPOINT_SOUNDTRANSIT\ORG\443\SITES\CAD\BEL\RED\E335-L86-LMP114.DWG

LEGEND:

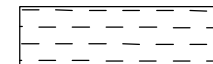
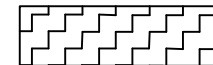
-  SCRUB-SHRUB BUFFER
-  SCRUB-SHRUB BUFFER - LOW
-  SCRUB-SHRUB WETLAND

NOTES:

1. RESTORE TEMPORARILY IMPACTED WETLANDS TO PREVIOUS GRADES.
2. SEE DWG L86-CXP113 FOR THE TREE AND VEGETATION PROTECTION/REMOVAL.
3. FOR STATION DESIGN SEE DRAWINGS E19-APP101 THRU E19-APP204.
4. FOR HARDSCAPE DESIGN SEE DRAWINGS E19-LSP101 THRU E19-LSP104.
5. FOR STREAM RELOCATION AND DRAINAGE DESIGN SEE CIVIL DRAINAGE DRAWINGS.

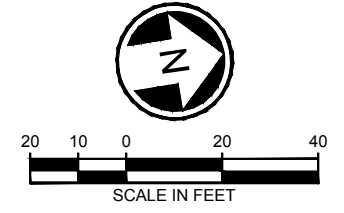

60% SUBMITTAL

DESIGNED BY:
J. LONG
 DRAWN BY:
J. LOGAN
 CHECKED BY:
B. ELROD
 APPROVED BY:
J. SCHUTT



LINE IS 1" AT FULL SCALE



SCALE:
1" = 20'
 FILENAME:
E335-L86-LMP114
 CONTRACT No.:
RTA/LR XXXX-XX
 DATE:
12/20/2013

**EAST LINK EXTENSION
 CONTRACT E335**
 DOWNTOWN BELLEVUE TO SPRING DISTRICT
 LANDSCAPE
 SITE RESTORATION PLAN
 CORRIDOR

DRAWING No.: L86-LMP114	
LOCATION ID:	
SHEET No.:	REV: 0

XREF LIST:
 XE335-GB-TR22x34
 XE335-L86-SEP100
 XE335-L86-CAP100
 XE335-L86-CMP100
 XE335-L86-CRP100
 XE335-L86-CZV020
 XE335-L86-SFP100
 XEL-0528cn
 XEL-0528rx
 XEL-0528rf
 XEL-0528ut
 XE335-L86-LMP100
 XEL-0531cn
 XEL-0531rx
 XEL-0531rf
 XEL-0531uf
 XE335-E19-LSP100
 GB-SEAL-JWL1135
 XE335-L86-KAP100
 XE335-L86-LIP100
 XE335-L86-SWP100
 XE335-L86-KAP010

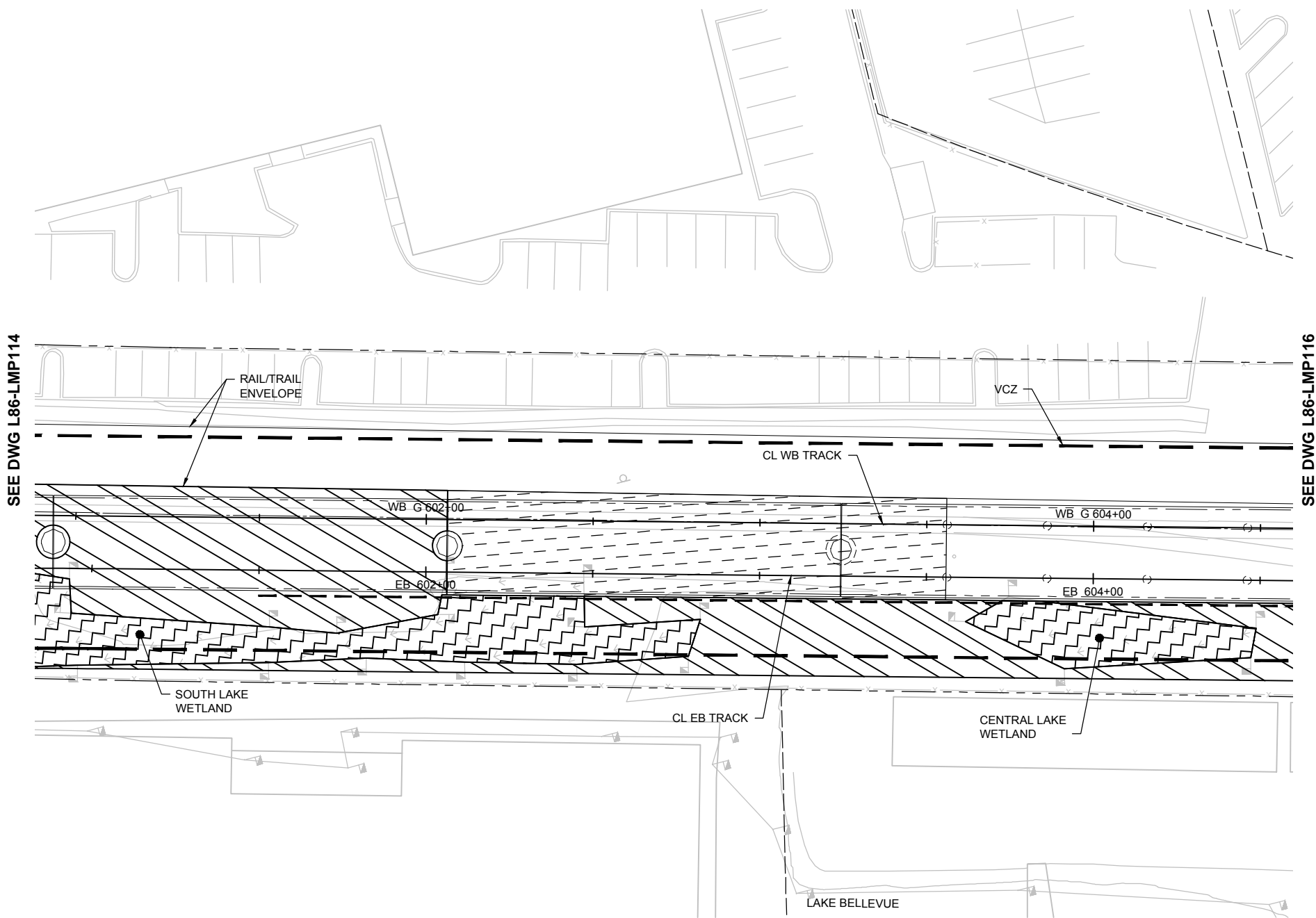

SEE DWG L86-LMP114

SEE DWG L86-LMP116

LEGEND:

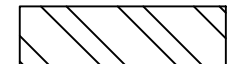
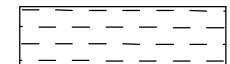
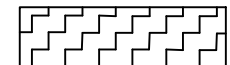
-  SCRUB-SHRUB BUFFER
-  SCRUB-SHRUB BUFFER - LOW
-  SCRUB-SHRUB WETLAND

NOTES:

1. RESTORE TEMPORARILY IMPACTED WETLANDS TO PREVIOUS GRADES.
2. SEE DWG L86-CXP113 FOR THE TREE AND VEGETATION PROTECTION/REMOVAL.
3. FOR STATION DESIGN SEE DRAWINGS E19-APP101 THRU E19-APP204.
4. FOR HARDSCAPE DESIGN SEE DRAWINGS E19-LSP101 THRU E19-LSP104.

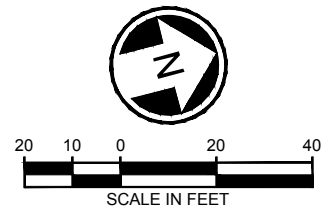

ORIGINATED BY: / DATE: /
 CORRECTED BY: / DATE: /
 CHECKED BY: / DATE: /
 VERIFIED BY: / DATE: /
 11/22/13 1:52 PM | CALDWELL
 C:\USERS\PUBLIC\DOCUMENTS\CALDWELL\HNTB\SHAREPOINT_SOUNDTRANSIT.ORG\443\SITES\CAD\BELLEVUE\DRAWINGS\E335-L86-LMP115.DWG

60% SUBMITTAL

DESIGNED BY:
J. LONG
 DRAWN BY:
J. LOGAN
 CHECKED BY:
B. ELROD
 APPROVED BY:
J. SCHUTT



LINE IS 1" AT FULL SCALE



SCALE:
1" = 20'
 FILENAME:
E335-L86-LMP115
 CONTRACT No.:
RTA/LR XXXX-XX
 DATE:
12/20/2013

**EAST LINK EXTENSION
 CONTRACT E335**
 DOWNTOWN BELLEVUE TO SPRING DISTRICT
 LANDSCAPE
 SITE RESTORATION PLAN
 CORRIDOR

DRAWING No.:
L86-LMP115
 LOCATION ID:
 SHEET No.: REV:
0

XREF LIST:
 XE335-L86-SFP100
 XE335-L86-RFP100
 XE335-L86-CAP100
 XE335-L86-LTP100
 XE335-L86-CGP100
 XE335-L86-LIP100
 XE335-L86-SEP100
 XE335-L86-KAP100
 XE335-L86-KAP010
 XE335-L86-KAP010

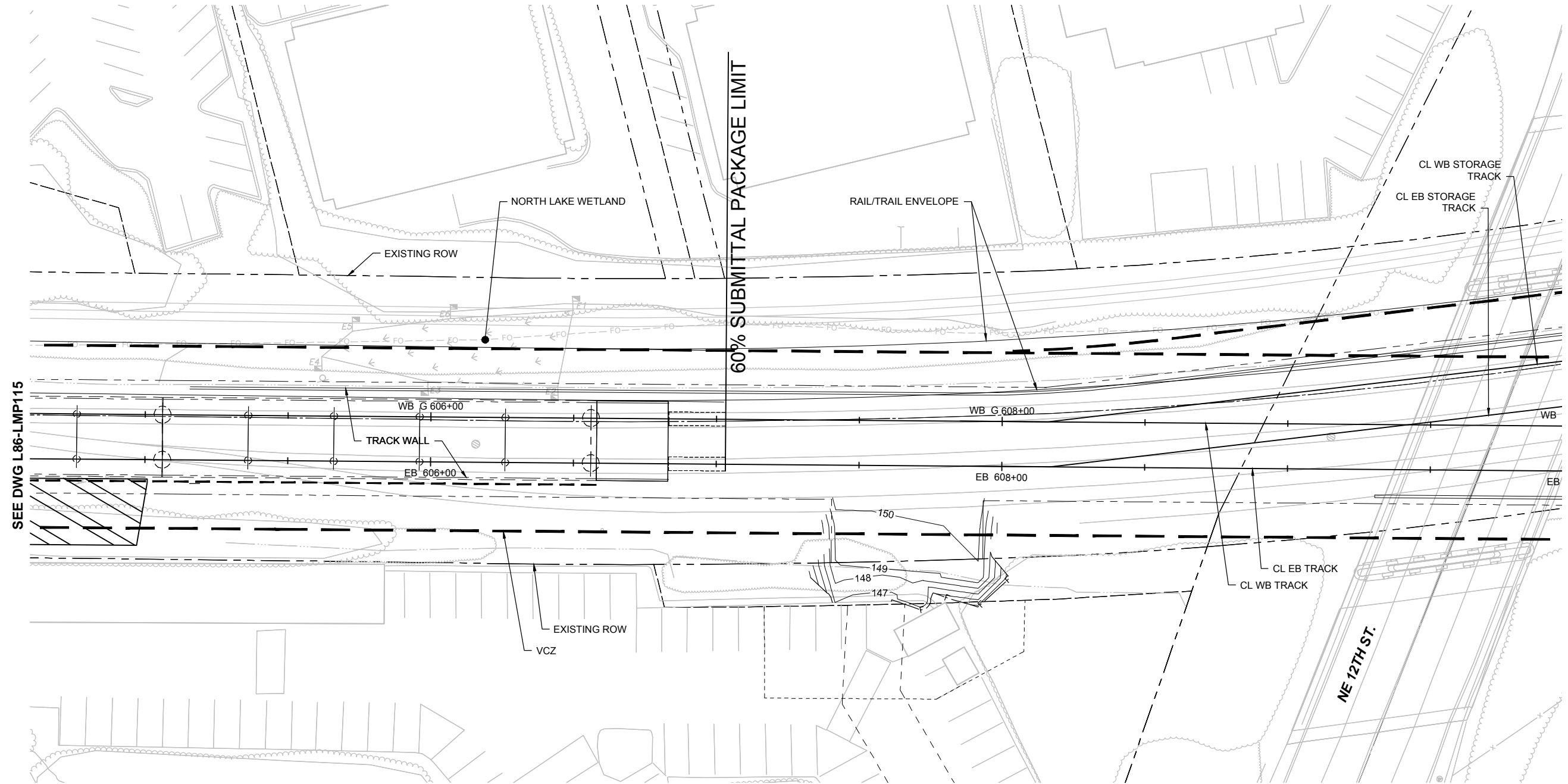

SEE DWG L86-LMP115

LEGEND:

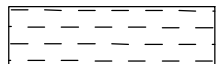
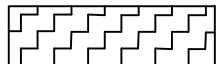
-  SCRUB-SHRUB BUFFER
-  SCRUB-SHRUB BUFFER - LOW
-  SCRUB-SHRUB WETLAND

NOTES:

1. RESTORE TEMPORARILY IMPACTED WETLANDS TO PREVIOUS GRADES.
2. SEE DWG L86-CXP113 FOR THE TREE AND VEGETATION PROTECTION/REMOVAL.

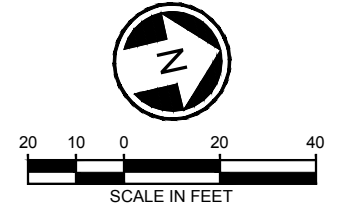

ORIGINATED BY: / DATE: /
 CORRECTED BY: / DATE: /
 CHECKED BY: / DATE: /
 BACK-CHECKED BY: / DATE: /
 11/22/13 1:53 PM | CALDWELL
 C:\USERS\PUBLIC\DOCUMENTS\CALDWELL\HNTB\SHAREPOINT_SOUNDTRANSIT\ORG\443\SITES\CAD\EL\BEL\RED\E335-L86-LMP116.DWG

60% SUBMITTAL

DESIGNED BY:
J. LONG
 DRAWN BY:
J. LOGAN
 CHECKED BY:
B. ELROD
 APPROVED BY:
J. SCHUTT



LINE IS 1" AT FULL SCALE



SCALE:
1" = 20'
 FILENAME:
E335-L86-LMP116
 CONTRACT No.:
RTA/LR XXXX-XX
 DATE:
12/20/2013

**EAST LINK EXTENSION
 CONTRACT E335**
 DOWNTOWN BELLEVUE TO SPRING DISTRICT
 LANDSCAPE
 SITE RESTORATION PLAN
 CORRIDOR

DRAWING No.:
L86-LMP116
 LOCATION ID:
 SHEET No.: REV:
0

XREF LIST:
 XE335-GB-TB22X34
 GB-SEAL-JWL1135

DETAIL IN PROGRESS

DETAIL IN PROGRESS

DETAIL IN PROGRESS

FORESTED BUFFER TYPICAL PLANTING

SCRUB-SHRUB BUFFER-LOW TYPICAL PLANTING

SCRUB-SHRUB WETLAND TYPICAL PLANTING

FORESTED BUFFER LIST

COMMON NAME	QTY	SIZE	SPACING
BEAKED HAZELNUT	XX	1 GAL.	5' O.C.
INDIAN PLUM	XX	1 GAL.	5' O.C.
KINNIKINNICK	XX	1 GAL.	5' O.C.
SALAL	XX	1 GAL.	5' O.C.
SNOWBERRY	XX	1 GAL.	5' O.C.
SWORD FERN	XX	1 GAL.	5' O.C.
TALL OREGON GRAPE	XX	1 GAL.	5' O.C.
VINE MAPLE	XX	1 GAL.	5' O.C.
WOODS ROSE	XX	1 GAL.	5' O.C.
BIG LEAF MAPLE	XX	1 GAL.	10' O.C.
BLACK HAWTHORNE	XX	1 GAL.	10' O.C.
DOUGLAS FIR	XX	1 GAL.	10' O.C.
WESTERN HEMLOCK	XX	1 GAL.	10' O.C.
WESTERN RED CEDAR	XX	1 GAL.	10' O.C.

SCRUB-SHRUB BUFFER LIST

COMMON NAME	QTY	SIZE	SPACING
BEAKED HAZELNUT	XX	1 GAL.	5' O.C.
INDIAN PLUM	XX	1 GAL.	5' O.C.
KINNIKINNICK	XX	1 GAL.	5' O.C.
LOW OREGON GRAPE	XX	1 GAL.	5' O.C.
NOOTKA ROSE	XX	1 GAL.	5' O.C.
SALAL	XX	1 GAL.	5' O.C.
SNOWBERRY	XX	1 GAL.	5' O.C.
SWORD FERN	XX	1 GAL.	5' O.C.
VINE MAPLE	XX	1 GAL.	5' O.C.
BLACK HAWTHORNE	XX	1 GAL.	10' O.C.
DOUGLAS FIR	XX	1 GAL.	10' O.C.
WESTERN RED CEDAR	XX	1 GAL.	10' O.C.

FORESTED WETLAND LIST

COMMON NAME	QTY	SIZE	SPACING
INDIAN PLUM	XX	1 GAL.	5' O.C.
SALAL	XX	1 GAL.	5' O.C.
SWORD FERN	XX	1 GAL.	5' O.C.
TALL OREGON GRAPE	XX	1 GAL.	5' O.C.
WOODS ROSE	XX	1 GAL.	5' O.C.

ORIGINATED BY: / DATE: /
 CHECKED BY: / DATE: /
 CORRECTED BY: / DATE: /
 VERIFIED BY: / DATE: /
 11/22/13 11:51 PM | CALDWELL
 C:\USERS\PUBLIC\DOCUMENTS\CALDWELL\HNTB\SHAREPOINT_SOUNDRANSIT\ORG\443\SITES\CAD\ELBEL\RED\E335-L86-LMD101.DWG

60% SUBMITTAL

DESIGNED BY:
J. LONG
 DRAWN BY:
J. LOGAN
 CHECKED BY:
B. ELROD
 APPROVED BY:
J. SCHUTT



LINE IS 1" AT
FULL SCALE



SCALE:
AS NOTED
 FILENAME:
E335-L86-LMD101
 CONTRACT No.:
RTA/LR XXXX-XX
 DATE:
12/20/2013

**EAST LINK EXTENSION
 CONTRACT E335**
 DOWNTOWN BELLEVUE TO SPRING DISTRICT
 LANDSCAPE
 SITE RESTORATION DETAILS
 CORRIDOR

DRAWING No.:
L86-LMD101
 LOCATION ID:
 SHEET No.: REV:
0

No.	DATE	DSN	CHK	APP	REVISION

XREF LIST:
 E335-GB-TR22x34
 GB-SEAL-JWL1135

STREAM BANK PLANT LIST

HYDROSEED MIX			
QTY	PERCENTAGE	COMMON NAME	BOTANICAL NAME
XX	XX	XXXXX	XXXXX
XX	XX	XXXXX	XXXXX
XX	XX	XXXXX	XXXXX
XX	XX	XXXXX	XXXXX
XX	XX	XXXXX	XXXXX
XX	XX	XXXXX	XXXXX
XX	XX	XXXXX	XXXXX
XX	XX	XXXXX	XXXXX

LIVE STAKES			
QTY	SPACING	COMMON NAME	BOTANICAL NAME
XX	XX	XXXXX	XXXXX
XX	XX	XXXXX	XXXXX





SCRUB-SHRUB WETLAND TOTALS

COMMON NAME	BOTANICAL NAME	QTY	SIZE	SPACING	NOTES
LADY FERN	ATHYRIUM FILIX-FEMINA	XX	1 GAL.	5' O.C.	NOTES
PACIFIC NINEBARK	PHYSOCARPUS CAPITATUS	XX	1 GAL.	5' O.C.	NOTES
RED OSIER DOGWOOD	CORNUS SERICEA	XX	1 GAL.	5' O.C.	NOTES
SALMONBERRY	RUBUS SPECTABILIS	XX	1 GAL.	5' O.C.	NOTES
SANDBAR WILLOW	SALIX EXIGUA	XX	1 GAL.	5' O.C.	NOTES
TWINBERRY	LONICERA INVOLUCRATA	XX	1 GAL.	5' O.C.	NOTES
OREGON ASH	FRAXINUS LATIFOLIA	XX	1 GAL.	10' O.C.	NOTES
PACIFIC WILLOW	SALIX LASIANDRA	XX	1 GAL.	10' O.C.	NOTES
WESTERN RED CEDAR	THUJA PLICATA	XX	1 GAL.	10' O.C.	NOTES

SCRUB-SHRUB BUFFER LOW TOTALS

COMMON NAME	BOTANICAL NAME	QTY	SIZE	SPACING	NOTES
BEAKED HAZELNUT	CORYLUS CORNUTA	XX	1 GAL.	5' O.C.	LOW
INDIAN PLUM	OEMLERIA CERASIFORMIS	XX	1 GAL.	5' O.C.	LOW
KINNICKINNICK	ARCTOSTAPHYLOS UVA-URSI	XX	1 GAL.	5' O.C.	LOW
LOW OREGON GRAPE	MAHONIA NERVOSA	XX	1 GAL.	5' O.C.	LOW
NOOTKA ROSE	ROSA NUTKANANA	XX	1 GAL.	5' O.C.	LOW
SALAL	GAULTHERIA SHALLON	XX	1 GAL.	5' O.C.	LOW
SNOWBERRY	SYMPHORICARPOS ALBUS	XX	1 GAL.	5' O.C.	LOW
SWORD FERN	POLYSTICHUM MUNITUM	XX	1 GAL.	5' O.C.	LOW
VINE MAPLE	ACER CIRCINATUM	XX	1 GAL.	5' O.C.	LOW
BLACK HAWTHORNE	CRATAEGUS DOUGLASII	XX	1 GAL.	10' O.C.	NOTES
DOUGLAS FIR	PSEUDOTSUGA MENZIESII	XX	1 GAL.	10' O.C.	NOTES
WESTERN RED CEDAR	THUJA PLICATA	XX	1 GAL.	10' O.C.	NOTES

ORIGINATED BY: / DATE: / / CORRECTED BY: / DATE: / /
 CHECKED BY: / DATE: / / VERIFIED BY: / DATE: / /
 11/22/13 1:51 PM | CALDWELL
 C:\USERS\PUBLIC\DOCUMENTS\CALDWELL\HNTB\SHARPOINT_SOUNDTRANSIT.ORG\443\SITES\CAD\BELLBEL\RED\E335-L86-LMD102.DWG

60% SUBMITTAL						DESIGNED BY: J. LONG	  	SCALE: AS NOTED	EAST LINK EXTENSION CONTRACT E335 DOWNTOWN BELLEVUE TO SPRING DISTRICT LANDSCAPE SITE RESTORATION DETAILS CORRIDOR	DRAWING No.: L86-LMD102
						DRAWN BY: J. LOGAN		FILENAME: E335-L86-LMD102		LOCATION ID:
						CHECKED BY: B. ELROD		CONTRACT No.: RTA/LR XXXX-XX		SHEET No.: REV:
						APPROVED BY: J. SCHUTT		DATE: 12/20/2013		0
No.	DATE	DSN	CHK	APP	REVISION	 JASON WILLIAM LONG LICENSE NO. 1135 EXPIRES ON:	LINE IS 1" AT FULL SCALE 	SoundTransit		

XREF LIST:
 XE335-GB-TR22-34
 GB-SEA-L-JMK.1.135
 XE335-E19-AYC300
 XE335-E19-AEX100
 XE335-E19-AEX104

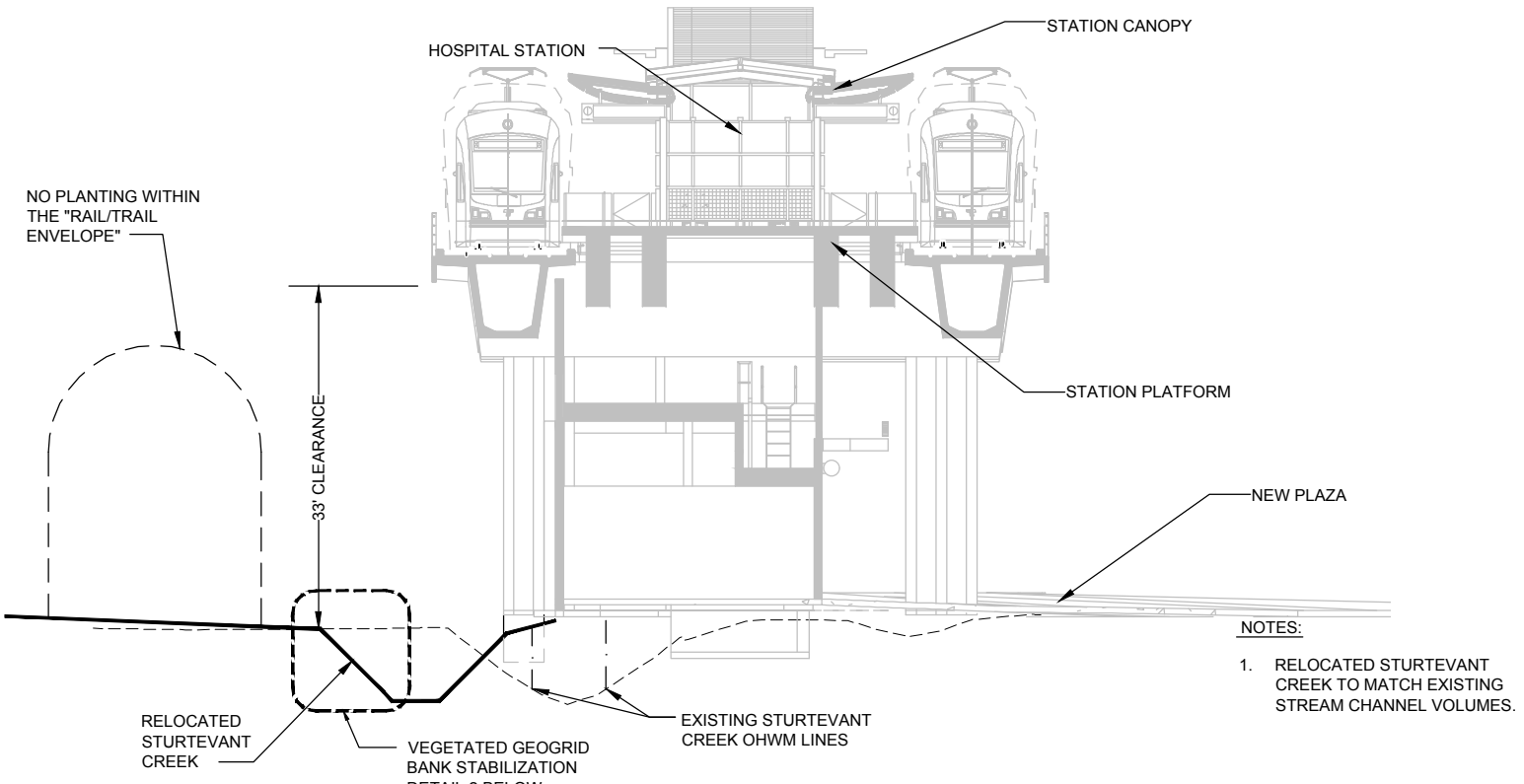

NOTES:
 1. RELOCATED STURTEVANT CREEK TO MATCH EXISTING STREAM CHANNEL VOLUMES.

RELOCATED STURTEVANT CREEK - TYPICAL SECTION
 NOT TO SCALE

TREE PROTECTION TABLE

SHEET	PNT	SPECIES	DBH	DRIP LINE
XXXXX	XX	XXXXX	XX	XX
XXXXX	XX	XXXXX	XX	XX
XXXXX	XX	XXXXX	XX	XX
XXXXX	XX	XXXXX	XX	XX
XXXXX	XX	XXXXX	XX	XX
XXXXX	XX	XXXXX	XX	XX
XXXXX	XX	XXXXX	XX	XX
XXXXX	XX	XXXXX	XX	XX
XXXXX	XX	XXXXX	XX	XX
XXXXX	XX	XXXXX	XX	XX
XXXXX	XX	XXXXX	XX	XX
XXXXX	XX	XXXXX	XX	XX
XXXXX	XX	XXXXX	XX	XX
XXXXX	XX	XXXXX	XX	XX
XXXXX	XX	XXXXX	XX	XX
XXXXX	XX	XXXXX	XX	XX
XXXXX	XX	XXXXX	XX	XX
XXXXX	XX	XXXXX	XX	XX
XXXXX	XX	XXXXX	XX	XX
XXXXX	XX	XXXXX	XX	XX
XXXXX	XX	XXXXX	XX	XX

ORIGINATED BY: / DATE: / CORRECTED BY: / DATE: /
 CHECKED BY: / DATE: / VERIFIED BY: / DATE: /
 11/22/13 1:51 PM | CALDWELL
 C:\USERS\PUBLIC\DOCUMENTS\CALDWELL\HNTB\SHAREPOINT_SOUNDTRANSIT\ORG\443\SITES\CAD\LEVEL\REDIE335\L86-LMD103.DWG

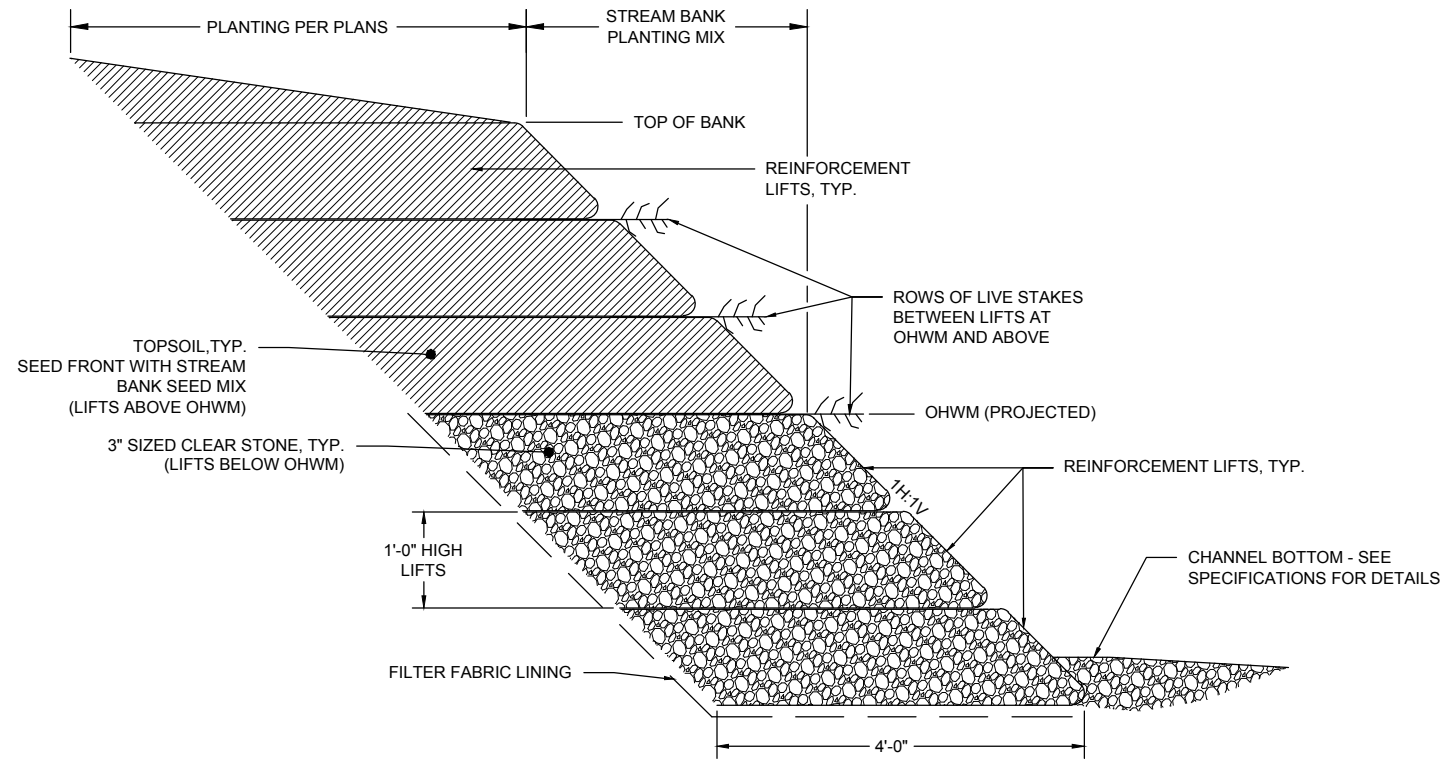

VEGETATED GEOGRID BANK STABILIZATION - TYPICAL SECTION
 NOT TO SCALE

60% SUBMITTAL

DESIGNED BY:
J. LONG
 DRAWN BY:
J. LOGAN
 CHECKED BY:
B. ELROD
 APPROVED BY:
J. SCHUTT

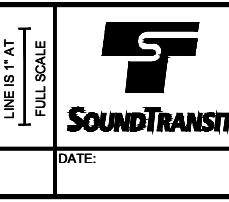
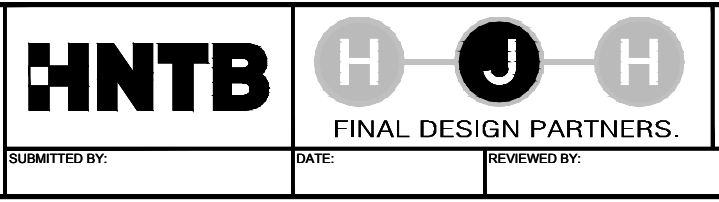

SCALE:
AS NOTED
 FILENAME:
E335-L86-LMD103
 CONTRACT No.:
RTA/LR XXXX-XX
 DATE:
12/20/2013

EAST LINK EXTENSION
CONTRACT E335
 DOWNTOWN BELLEVUE TO SPRING DISTRICT
 LANDSCAPE
 SITE RESTORATION DETAILS
 CORRIDOR

DRAWING No.:
L86-LMD103
 LOCATION ID:
SHEET No.: REV:
0

XREF LIST:
 XE335-L86-CMP100
 XE335-L86-KAP100
 XE335-L86-SFP100
 XEL-0525x
 XEL-0525u
 XE335-G8-TB22x34
 XEL-0525f
 XEL-0525v
 XE335-L86-CGP100
 XE335-L86-CGP100
 XE335-L86-CRP100
 XE335-L86-RPP100
 XE335-L86-CLP100
 XE335-L86-TSP100
 XE335-L86-JEP100
 GB-SEAL-JBVB57
 XE335-E11-APP100
 XE335-E11-LSP100
 XE335-E11-APP100
 XE335-L86-CAP100
 XE335-L86-GZV020
 XE335-L86-SWP100
 XE335-E11-LPP100
 XE335-L86-LCP100
 XE335-L86-LPP100
 XE335-L86-LPP101
 XE320-L85-SWP100
 XE320-L85-LPP101
 XE320-L85-RPP100
 XE320-L85-KAP100
 XE320-L85-CRP100
 XE335-E11-LRP100

ORIGINATED BY: / DATE: /
 CHECKED BY: / DATE: /
 BACK-CHECKED BY: / DATE: /
 11/26/13 7:18 AM CALDWELL
 C:\USERS\PUBLIC\DOCUMENTS\CALDWELL\HITTPS\SHAREPOINT\ SOUNDTRANSIT\ORG\443\SITES\CAD\EL\BEL\RED\E335\L86-LPP100.DWG

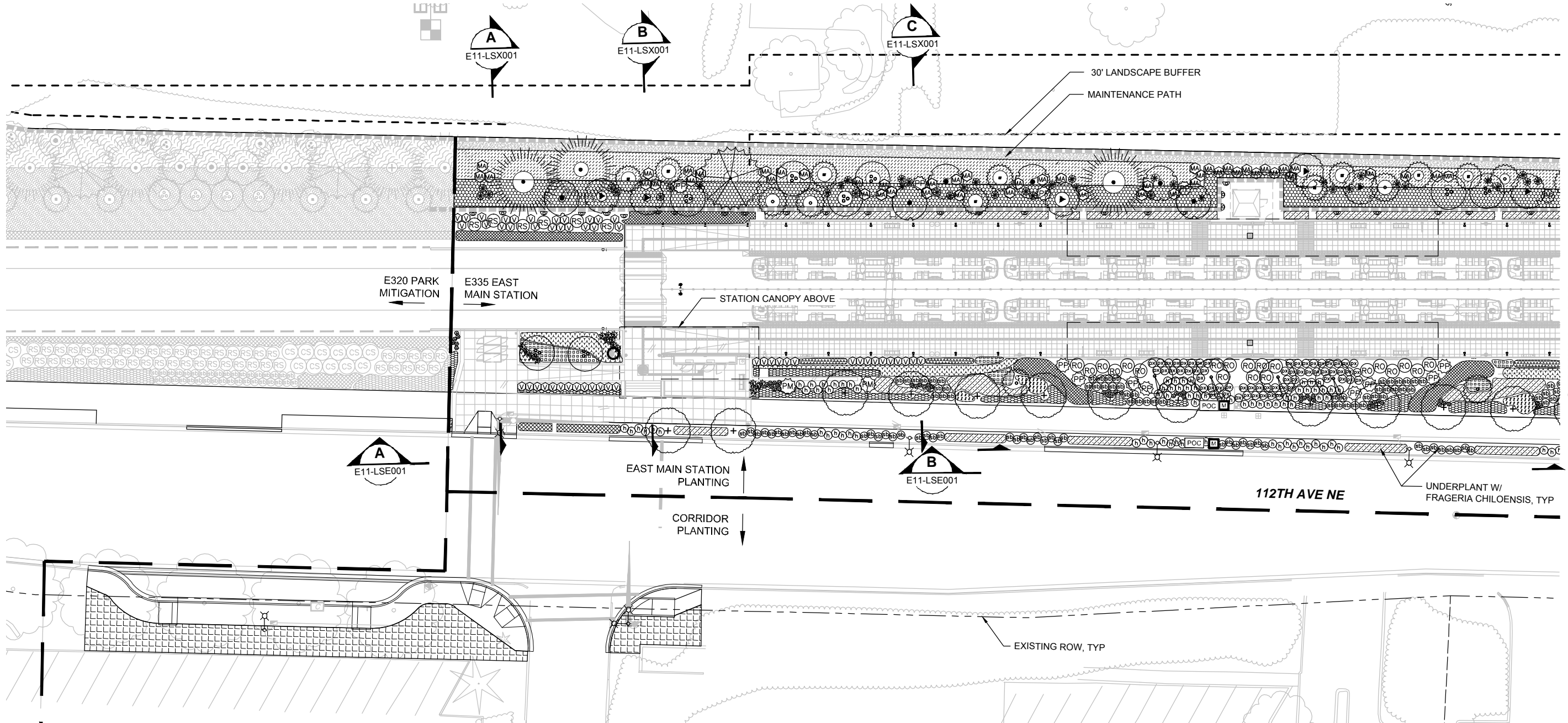

SEE DWG L86-LPP101

- NOTES:**
- SEE DWG L85-LPS100 FOR CORRIDOR PLANT SCHEDULE.
 - SEE DWG L85-LPS101 FOR E MAIN STATION AREA PLANT SCHEDULE.

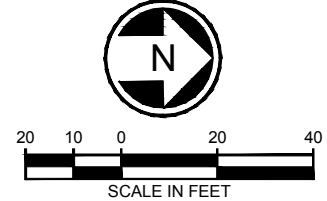

60% SUBMITTAL

DESIGNED BY:
A. WEST
 DRAWN BY:
N. MARSHALL
 CHECKED BY:
M. YAMAGUCHI
 APPROVED BY:
J. SCHUTT

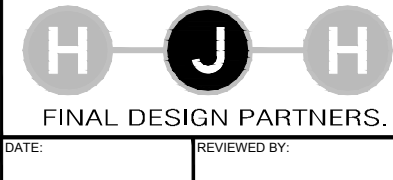
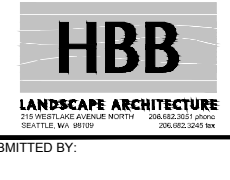

LINE IS 1" AT FULL SCALE



SCALE:
1" = 20'
 FILENAME:
E335-L86-LPP100
 CONTRACT No.:
RTA/LR XXXX-XX
 DATE:
12/20/2013

**EAST LINK EXTENSION
 CONTRACT E335**
 DOWNTOWN BELLEVUE TO SPRING DISTRICT
 LANDSCAPE
 PLANTING PLAN
 CORRIDOR

DRAWING No.:
L86-LPP100
 LOCATION ID:
 SHEET No.: REV:
0

XREF LIST:
 XE335-L86-CAP100
 XE335-L86-CMP100
 XE335-L86-SFP100
 XE335-L86-CDP100
 XEL-0525rx
 XEL-0525sf
 XEL-0525ul
 XEL-0528rx
 XEL-0528sf
 XEL-0528ul
 XE335-GB-TB22x34
 XE335-L86-RPP100
 XE335-L86-CGP100
 XE335-L86-JEP100
 XE335-L86-UCP100
 XE335-L86-CRP100
 XE335-L86-CPP100
 GB-SEAL-BV857
 XE335-L86-LSP101
 XE335-E11-LPP100
 XE335-L86-SWP100
 XEL-0525vg
 XEL-0528vg
 XE335-E11-APP100
 XE335-E11-APP100
 XE335-E11-LSP100
 XE335-L86-CZV1020
 XE330-T86-SWP100
 XE335-L86-LPP100
 XE335-L86-LPP101
 XE330-T86-CGP100
 XE320-L85-SWP100
 XE335-L86-APP100
 XE330-T86-CRP100
 XE335-L86-KAP100
 XE335-L86-CLP100

ORIGINATED BY: / DATE: /
 CHECKED BY: / DATE: /
 BACK-CHECKED BY: / DATE: /
 11/28/13 | 7:19 AM | CALDWELL
 C:\USERS\PUBLIC\DOCUMENTS\CALDWELL\H\TTPS\SHAREPOINT\SOUNDTRANSIT\ORG\443\SITES\CAD\EL\BEL\RED\E335\L86-LPP101.DWG

SEE DWG L86-LPP141

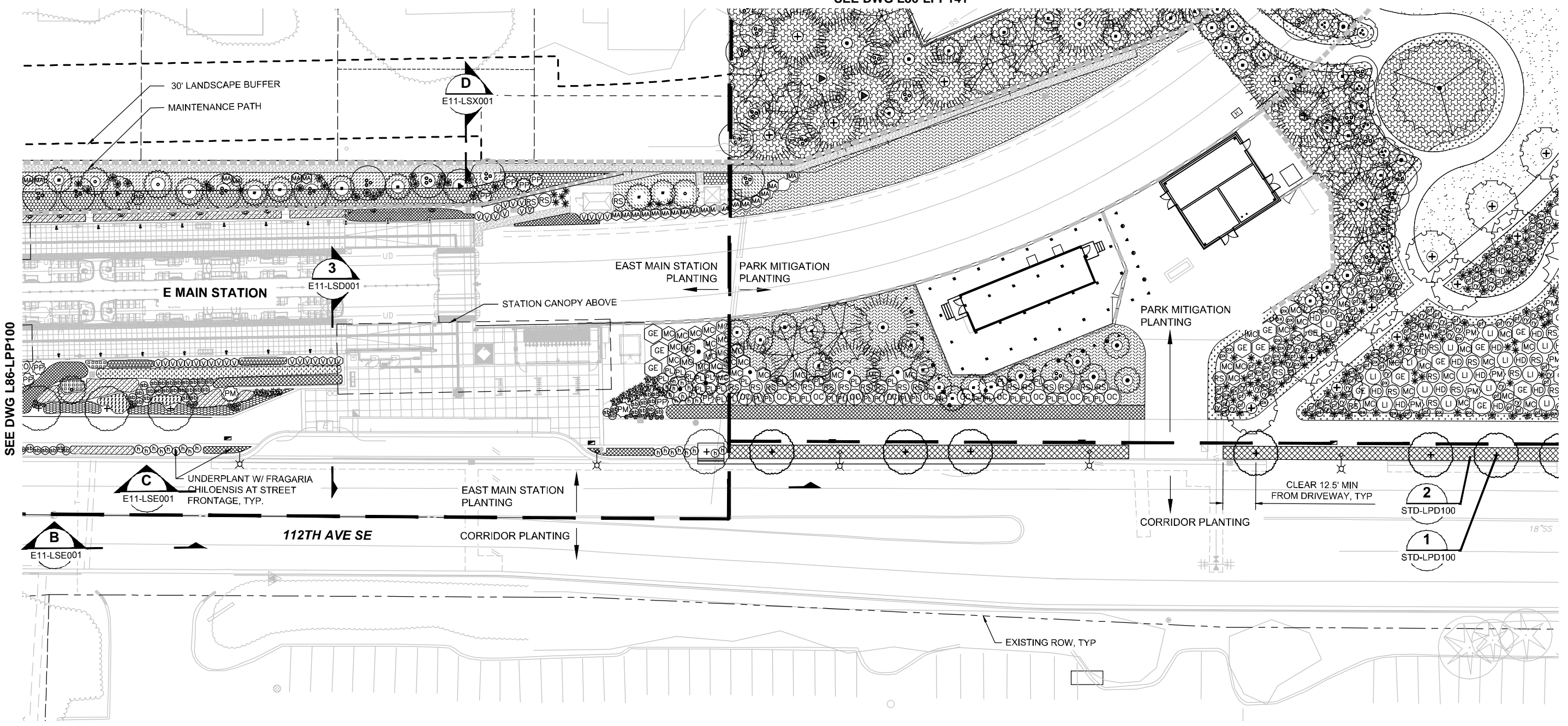

- NOTES:**
- SEE DWG L86-LPS100 FOR CORRIDOR PLANT SCHEDULE.
 - SEE DWG L86-LPS101 FOR E MAIN STATION PLANT SCHEDULE.
 - SEE DWG L86-LPS103 FOR PARK MITIGATION PLANT SCHEDULE.

60% SUBMITTAL

DESIGNED BY:
J. YONG
 DRAWN BY:
R. DOTSON
 CHECKED BY:
D. KOONTS
 APPROVED BY:
J. SCHUTT

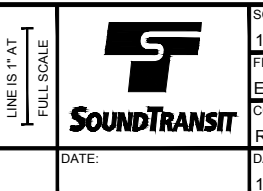
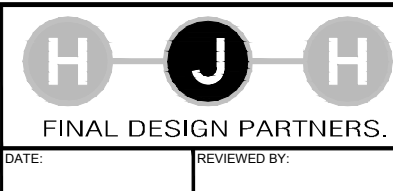

SCALE:
1" = 20'
 FILENAME:
E335-L86-LPP101
 CONTRACT No.:
RTA/LR XXXX-XX
 DATE:
12/20/2013

**EAST LINK EXTENSION
 CONTRACT E335**
 DOWNTOWN BELLEVUE TO SPRING DISTRICT
 LANDSCAPE
 PLANTING PLAN
 CORRIDOR

DRAWING No.:
L86-LPP101
 LOCATION ID:
 SHEET No.: REV:
0

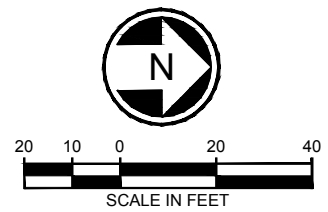

XREF LIST:
 XE335-L86-CAP100
 XE335-L86-CMP100
 XE335-L86-KAP100
 XE335-L86-LPP100
 XE335-L86-SFP100
 XE335-L86-CDP100
 XEL-0528r
 XEL-0528f
 XEL-0528u
 XE335-CB-TR22x34
 XE335-L86-RPP100
 XE335-L86-CRP100
 XE335-L86-CGP100
 XE335-L86-CLP100
 XE335-L86-CPP100
 XE335-L86-JEP100
 XE335-L86-UCP100
 GB-SEAL-JBVB57
 XE335-L86-LPP101
 XE335-L86-LSP101
 XE330-T86-STP002
 XE330-T86-STP001
 XE335-L86-SWP100
 XEL-0528g
 XE335-L86-GZV020

SEE DWG L86-LPP101

SEE DWG L86-LPP141

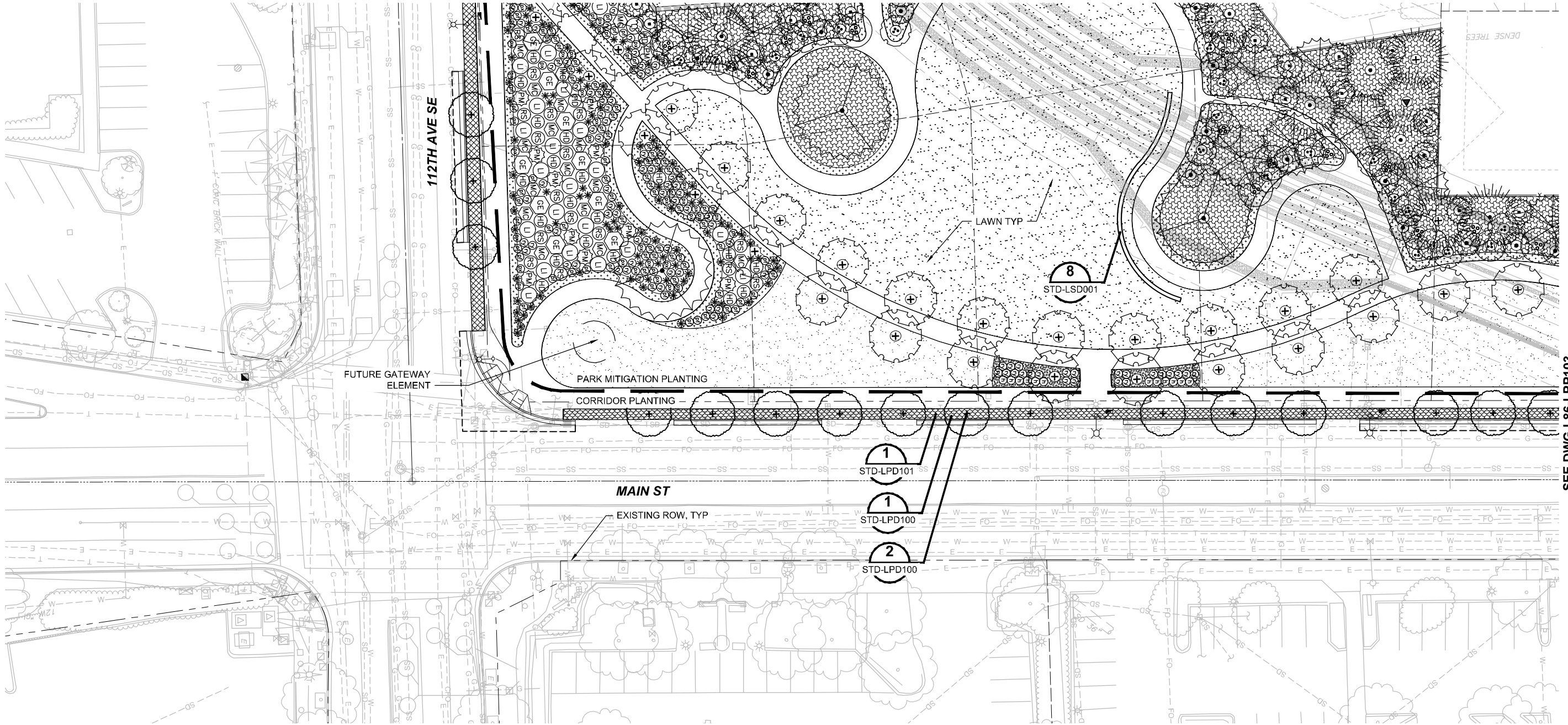

SEE DWG L86-LPP103

NOTES:

- SEE DWG L86-LPS100 FOR CORRIDOR PLANT SCHEDULE.
- SEE DWG L86-LPS103 FOR PARK MITIGATION PLANT SCHEDULE.
- SEE DWG L86-CGP101, CGP102, CGP103, CGP141 FOR CIVIL GRADING & PAVING PLAN.
- RETAINING WALL TOP WIDTH: 12"
 UPHILL SIDE HT. (FROM FIN. GR.): 18"
 DOWNHILL SIDE HT. (FROM FIN. GR.): 30"

ORIGINATED BY: / DATE: /
 CHECKED BY: / DATE: /
 BACK-CHECKED BY: / DATE: /
 11/26/13 | 3:08 PM | CALDWELL
 C:\USERS\PUBLIC\DOCUMENTS\CALDWELL\H\TTPS\SHAREPOINT\SOUNDTRANSIT\ORG\443\SITES\CAD\ELBEL\RED\E335-L86-LPP102.DWG

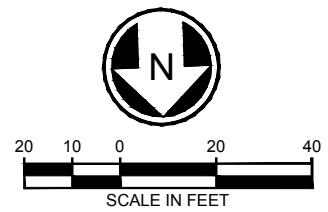

60% SUBMITTAL

DESIGNED BY:
J. YONG
 DRAWN BY:
R. DOTSON
 CHECKED BY:
D. KOONTS
 APPROVED BY:
J. SCHUTT

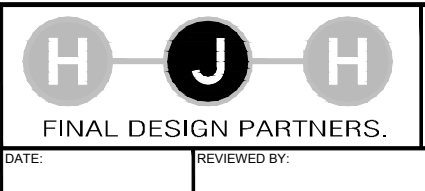

SCALE:
 1" = 20'
 FILENAME:
E335-L86-LPP102
 CONTRACT No.:
RTA/LR XXXX-XX
 DATE:
12/20/2013

**EAST LINK EXTENSION
 CONTRACT E335**
 DOWNTOWN BELLEVUE TO SPRING DISTRICT
 LANDSCAPE
 PLANTING PLAN
 CORRIDOR

DRAWING No.:
L86-LPP102
 LOCATION ID:
 SHEET No.: REV:
 0

No.	DATE	DSN	CHK	APP	REVISION

XREF LIST:
 XE335-L86-CAP100
 XE335-L86-CMP100
 XE335-L86-KAP100
 XE335-L86-LPP100
 XE335-L86-SFP100
 XE335-L86-CDP100
 XEL-0228rx
 XEL-0228uf
 XEL-0228u
 XEL-0528rx
 XEL-0528uf
 XEL-0528u
 XE335-03-TR22x34
 XE335-L86-RPP100
 XE335-L86-CRP100
 XE335-L86-CP100
 XE335-L86-CLP100
 XE335-L86-JEP100
 XE335-L86-CPP100
 XE335-L86-UCP100
 GB-SEAL-BV857
 XE330-T86-STP001
 XE330-T86-STP002
 XE335-L86-LPP101
 XE335-L86-LSP101
 XE335-L86-SWP100
 XEL-0528vg
 XE335-L86-GZV020

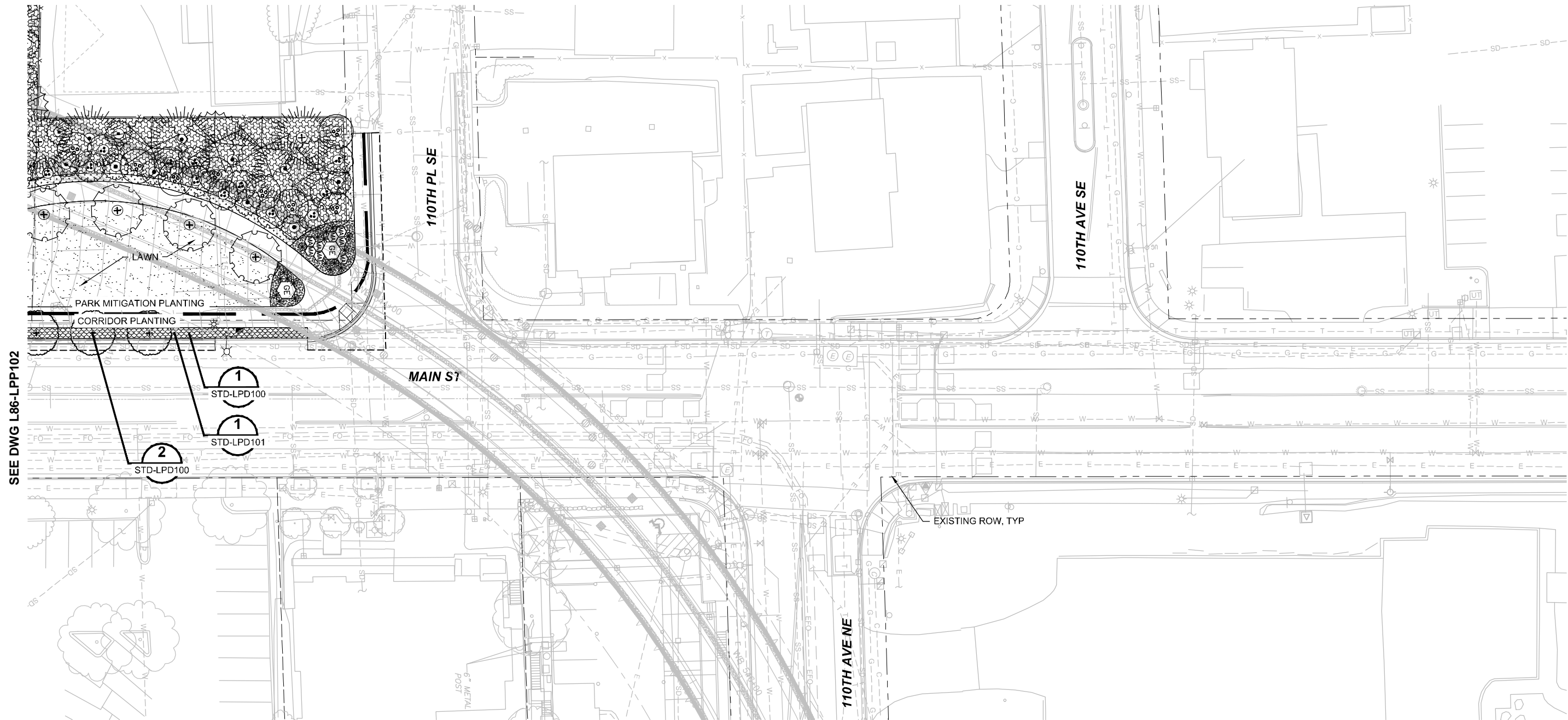

SEE DWG L86-LPP102

EXISTING ROW, TYP

NOTES:

- SEE DWG L86-LPS100 FOR CORRIDOR PLANT SCHEDULE.
- SEE DWG L86-LPS103 FOR PARK MITIGATION PLANT SCHEDULE.

ORIGINATED BY: / DATE: /
 CHECKED BY: / DATE: /
 BACK-CHECKED BY: / DATE: / CALDWELL
 11/26/13 | 3:08 PM | CALDWELL
 C:\USERS\PUBLIC\DOCUMENTS\CALDWELL\H\TTPS\SHAREPOINT\SOUNDTRANSIT\ORG\443\SITES\CAD\EL\BEL\RED\E335\DRAWINGS\E335-L86-LPP103.DWG

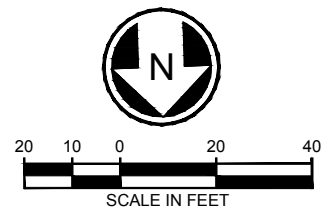

60% SUBMITTAL

DESIGNED BY:
J. YONG
 DRAWN BY:
R. DOTSON
 CHECKED BY:
D. KOONTS
 APPROVED BY:
J. SCHUTT

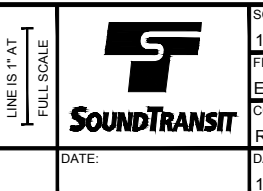
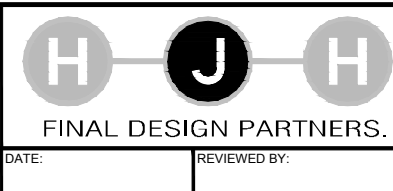

SCALE:
1" = 20'
 FILENAME:
E335-L86-LPP103
 CONTRACT No.:
RTA/LR XXXX-XX
 DATE:
12/20/2013

**EAST LINK EXTENSION
 CONTRACT E335**
 DOWNTOWN BELLEVUE TO SPRING DISTRICT
 LANDSCAPE
 PLANTING PLAN
 CORRIDOR

DRAWING No.:
L86-LPP103
 LOCATION ID:
 SHEET No.: REV:
 0

No.	DATE	DSN	CHK	APP	REVISION

XREF LIST:
 XE335-L86-CAP100
 XE335-L86-CMP100
 XE335-L86-KAP100
 XE335-L86-LPP100
 XE335-L86-SFP100
 XE335-L86-CDP100
 XEL-0228r
 XEL-0228f
 XEL-0229r
 XEL-0229f
 XEL-0528r
 XEL-0528f
 XEL-0528t
 XE335-03-TR22x34
 XE335-L86-RPP100
 XE335-L86-CRP100
 XE335-L86-CGP100
 XE335-L86-EP100
 XE335-L86-CPP100
 XE335-L86-CLP100
 XE335-L86-UCP100
 XE335-E11-LPP100
 XE335-L86-LPP101
 XEL-0229g
 XE330-T86-STP001
 XE335-L86-LTP100
 GB-SEAL-MY371

ORIGINATED BY: / DATE: /
 CORRECTED BY: / DATE: /
 CHECKED BY: / DATE: /
 VERIFIED BY: / DATE: /

11/28/13 | 3:09 PM | CALDWELL
 BACK-CHECKED BY: / DATE: /
 CALDWELL | C:\DWELL\PROJECTS\SHARPOINT\SOUNDTRANSIT\ORG\443\SITES\CAD\ELBEL\RED\E335-L86-LPP105.DWG

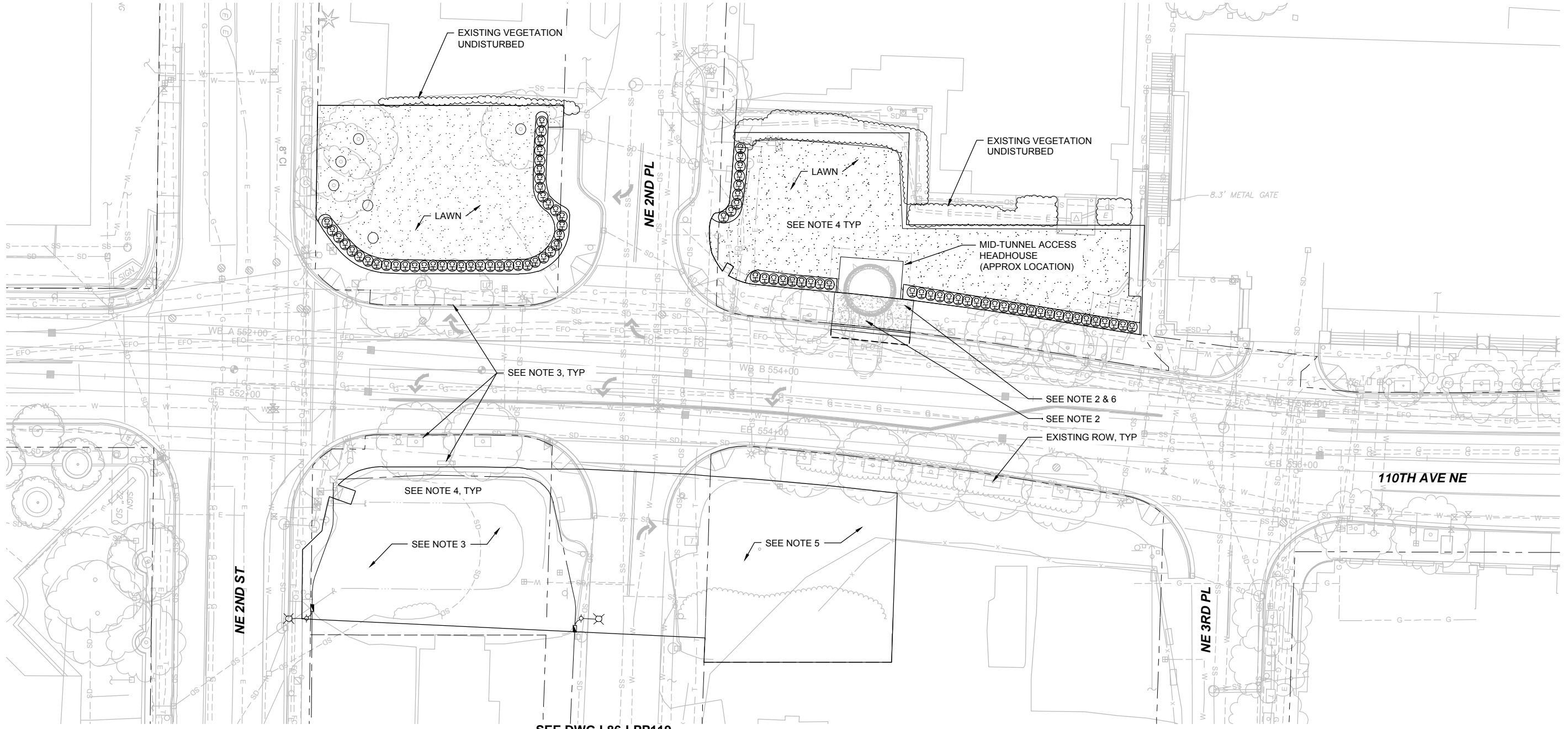

SEE DWG L86-LPP106

SEE DWG L86-LPP119

- NOTES:**
- SEE DWG L86-LPS103 FOR PARK MITIGATION PLANT SCHEDULE.
 - EXISTING STREETSCAPE TO REMAIN. ALL STREETSCAPE AMENITIES, INCLUDING BENCHES AND TRASH RECEPTACLES, SHALL REMAIN IN PLACE EXCEPT WHERE NOTED. ALL TREES, EXCEPT ONE ADJACENT TO TUNNEL ACCESS HEADHOUSE TO BE PROTECTED. SEE E330 CIVIL DEMO DWGS FOR LOCATION.
 - S.E. POCKET PARK: PRESERVE AND PROTECT FOR DURATION OF CONSTRUCTION. ALL LANDSCAPE PLANTINGS, GRASS LAWN, AND DRAINAGE STRUCTURES TO REMAIN.
 - ALL POCKET PARKS: CONTRACTOR SHALL USE DISCRETION REGARDING REMOVAL OF FURNISHINGS, INCLUDING PARK BENCHES, TRASH RECEPTACLES, POOP STATION, ETC.
 - REINSTALL ALL SITE FURNISHINGS IN THEIR ORIGINAL SITE LOCATIONS AT COMPLETION OF SITE LANDSCAPE RESTORATION.
 - N.E. POCKET PARK: FUTURE COMMERCIAL DEVELOPMENT TO PROVIDE PUBLIC PARK SPACE IN AREA SHOWN.
 - REMOVE SITE FURNISHING WHERE NOTED. PLACE IN STORAGE UNTIL PROJECT COMPLETION.

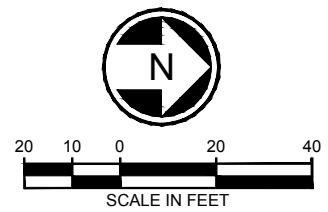

60% SUBMITTAL

DESIGNED BY:
M. YAMAGUCHI
 DRAWN BY:
H. BAUMANN
 CHECKED BY:
A. WEST
 APPROVED BY:
J. SCHUTT



NAKANO ASSOCIATES
 LANDSCAPE ARCHITECTS
 853 Hiawatha Place S.
 Seattle, WA 98144
 Tel: 206.292.9392
 www.nakanolandscape.com

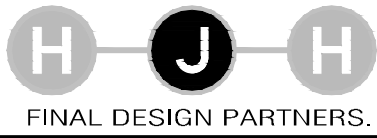

LINE IS 1" AT FULL SCALE



SCALE:
1" = 20'
 FILENAME:
E335-L86-LPP105
 CONTRACT No.:
RTA/LR XXXX-XX
 DATE:
12/20/2013

EAST LINK EXTENSION
CONTRACT E335
 DOWNTOWN BELLEVUE TO SPRING DISTRICT
 LANDSCAPE
 PLANTING PLAN
 MAIN ST PARK

DRAWING No.:
L86-LPP105
 LOCATION ID:
 SHEET No.: REV:
0

XREF LIST:
 XE330-E15-SFP400
 XE335-L86-CAP100
 XE335-L86-CMP100
 XE335-L86-KAP100
 XE335-L86-LPP100
 XE335-L86-SFP100
 XE335-L86-CDP100
 XEL-0228rx
 XEL-0228rf
 XEL-0228rt
 XEL-0528rx
 XEL-0528rf
 XEL-0528rt
 XE335-GB-TB22x34
 XE335-L86-RPP100
 XE335-L86-CRP100
 XE335-L86-CGP100
 XE335-L86-CP100
 XE335-L86-JEP100
 XE335-L86-CLP100
 XE335-L86-UCP100
 XE330-T86-CCP001
 XE335-E15-LPP100
 XE335-E15-LSP100
 GB-SEAL-BV857
 XEL-0528vg
 XEL-0228vg

ORIGINATED BY: / DATE: /
 CHECKED BY: / DATE: /
 BACK-CHECKED BY: / DATE: /
 11/22/13 1:55 PM | CALDWELL
 C:\USERS\PUBLIC\DOCUMENTS\CALDWELL\HITTPS\SHAREPOINT\ SOUNDTRANSIT\ORG\443\SITES\CAD\EL\BEL\RED\E335-L86-LPP106.DWG

SEE DWG L86-LPP105

SEE DWG L86-LPP107

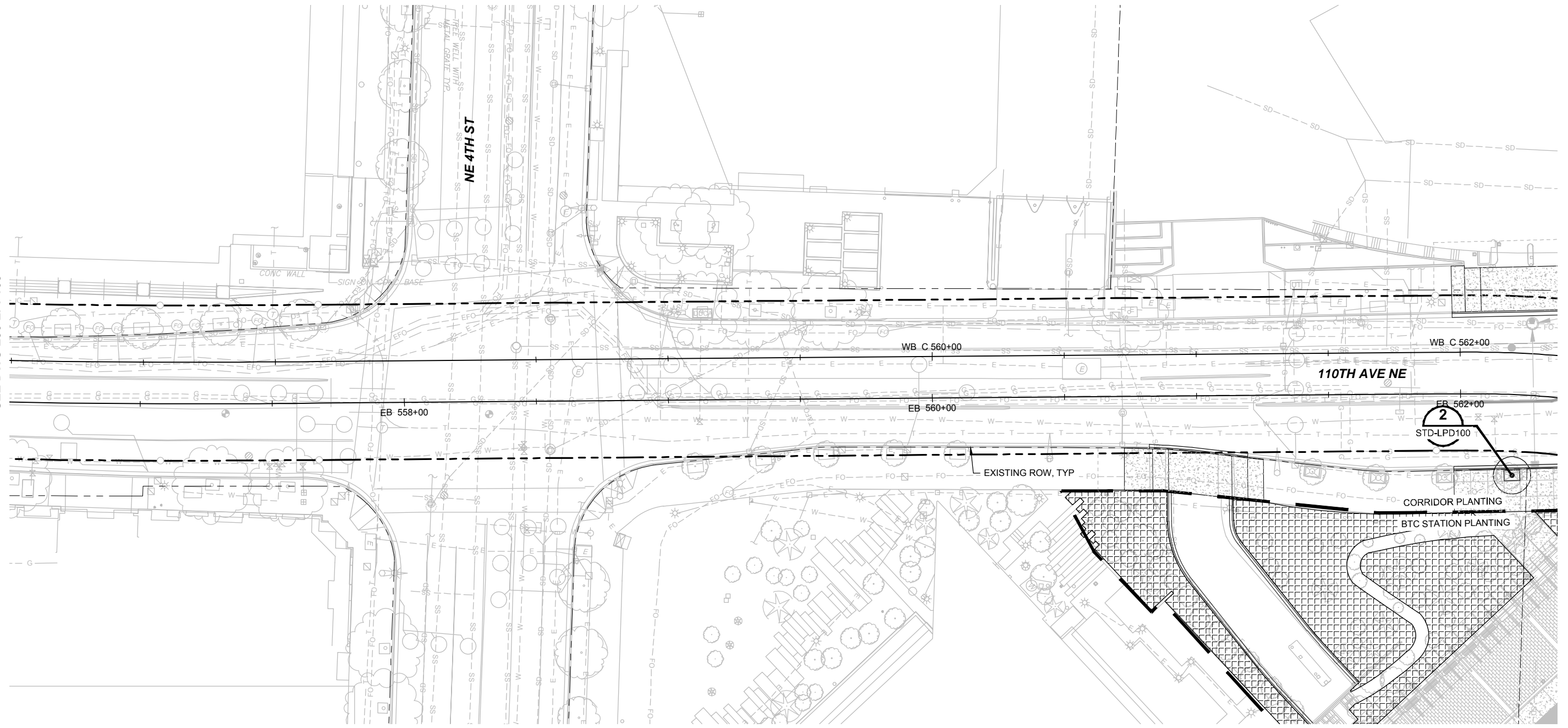

- NOTES:**
- SEE DWG L86-LPS100 FOR CORRIDOR PLANT SCHEDULE AND BTC STATION PLANT SCHEDULE.

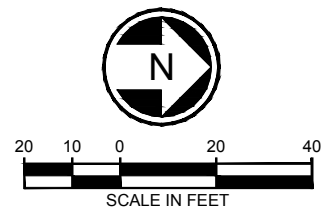

60% SUBMITTAL

DESIGNED BY:
J. YONG
 DRAWN BY:
R. DOTSON
 CHECKED BY:
D. KOONTS
 APPROVED BY:
J. SCHUTT

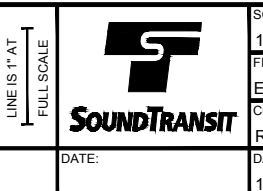
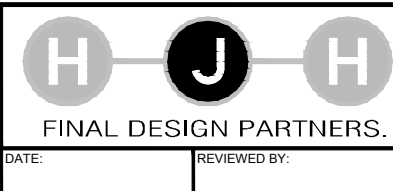

SCALE:
 1" = 20'
 FILENAME:
 E335-L86-LPP106
 CONTRACT No.:
 RTA/LR XXXX-XX
 DATE:
 12/20/2013

**EAST LINK EXTENSION
 CONTRACT E335**
 DOWNTOWN BELLEVUE TO SPRING DISTRICT
 LANDSCAPE
 PLANTING PLAN
 CORRIDOR

DRAWING No.:
L86-LPP106
 LOCATION ID:
 SHEET No.: REV:
 0

No.	DATE	DSN	CHK	APP	REVISION

XREF LIST:
 XE335-L86-CAP100
 XE335-L86-CMP100
 XE335-L86-KAP100
 XE335-L86-LPP100
 XE335-L86-SFP100
 XE335-L86-CDP100
 XEL-0228r
 XEL-0228f
 XEL-0228u
 XEL-0528r
 XEL-0528f
 XEL-0528u
 XE335-09-TR22x34
 XE335-L86-RPP100
 XE335-L86-CRP100
 XE335-L86-CGP100
 XE335-E15-LSP100
 XE335-L86-CPP100
 XE335-L86-EP100
 XE335-L86-CLP100
 XE335-L86-UCP100
 XE335-E15-APP400
 CB-SEAL-05V857
 XE335-L86-TSP100
 XEL-0528v
 XEL-0228v

ORIGINATED BY: / DATE: /
 CHECKED BY: / DATE: /
 BACK-CHECKED BY: / DATE: /
 11/26/13 7:19 AM CALDWELL
 C:\USERS\PUBLIC\DOCUMENTS\CALDWELL\H\H\TTPS\SHAREPOINT\SOUNDTRANSIT\ORG\443\SITES\CAD\ELBEL\RED\E335\L86-LPP107.DWG

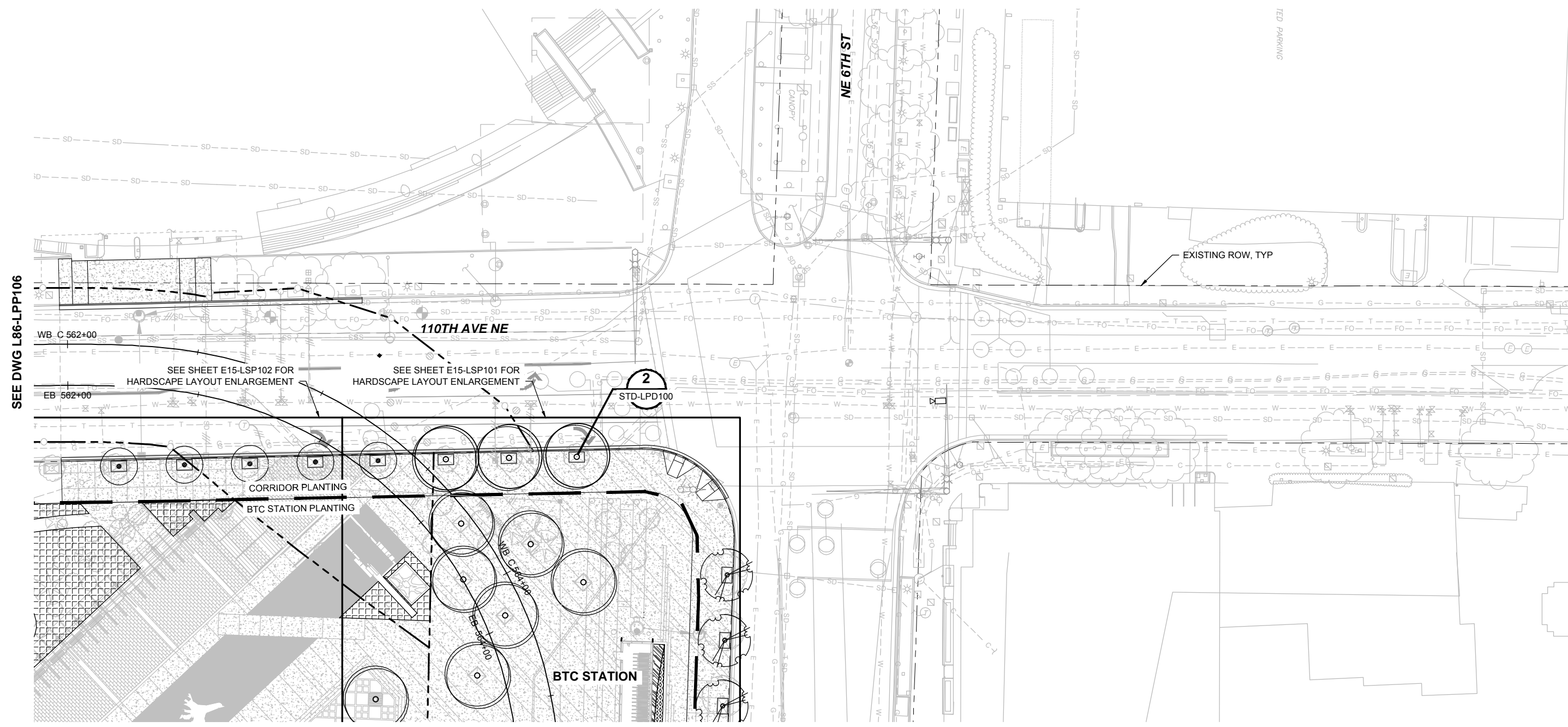

NOTES:
 1. SEE DWG L86-LPS100 FOR CORRIDOR PLANT SCHEDULE AND BTC STATION PLANT SCHEDULE.

60% SUBMITTAL

DESIGNED BY:
J. VONG
 DRAWN BY:
R. DOTSON
 CHECKED BY:
D. KOONTS
 APPROVED BY:
J. SCHUTT

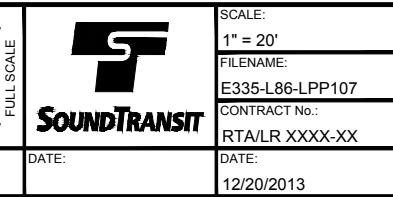
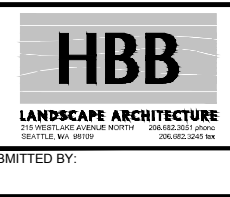

SCALE:
 1" = 20'
 FILENAME:
 E335-L86-LPP107
 CONTRACT No.:
 RTA/LR XXXX-XX
 DATE:
 12/20/2013

**EAST LINK EXTENSION
 CONTRACT E335**
 DOWNTOWN BELLEVUE TO SPRING DISTRICT

LANDSCAPE
 PLANTING PLAN
 CORRIDOR

DRAWING No.:
L86-LPP107
 LOCATION ID:
 SHEET No.:
 REV:
 0

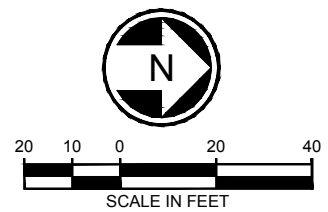

XREF LIST:
 XE335-L86-CAP100
 XE335-L86-CMP100
 XE335-L86-KAP100
 XE335-L86-LPP100
 XE335-L86-SFP100
 XE335-L86-CDP100
 XEL-0228r
 XEL-0228f
 XEL-0228u
 XEL-0528r
 XEL-0528f
 XEL-0528u
 XE335-03-TR22x34
 XE335-L86-RPP100
 XE335-L86-CRP100
 XE335-L86-CPP100
 XE335-L86-APP100
 XE335-E15-LPP100
 XE335-E15-LSP100
 XE335-E15-APP100
 XE335-L86-CLP100
 XE335-L86-CPP100
 XE335-L86-UCP100
 XE335-L86-EP100
 GB-SEAL-BV857
 XEL-0228v
 XEL-0528v

ORIGINATED BY: / DATE: /
 CHECKED BY: / DATE: /
 BACK-CHECKED BY: / DATE: /
 11/22/13 1:56 PM | CALDWELL
 C:\USERS\PUBLIC\DOCUMENTS\CALDWELL\HITTPS\SHAREPOINT\SOUNDTRANSIT\ORG\443\SITES\CAD\BELRED\E335\DRAWINGS\E335-L86-LPP108.DWG

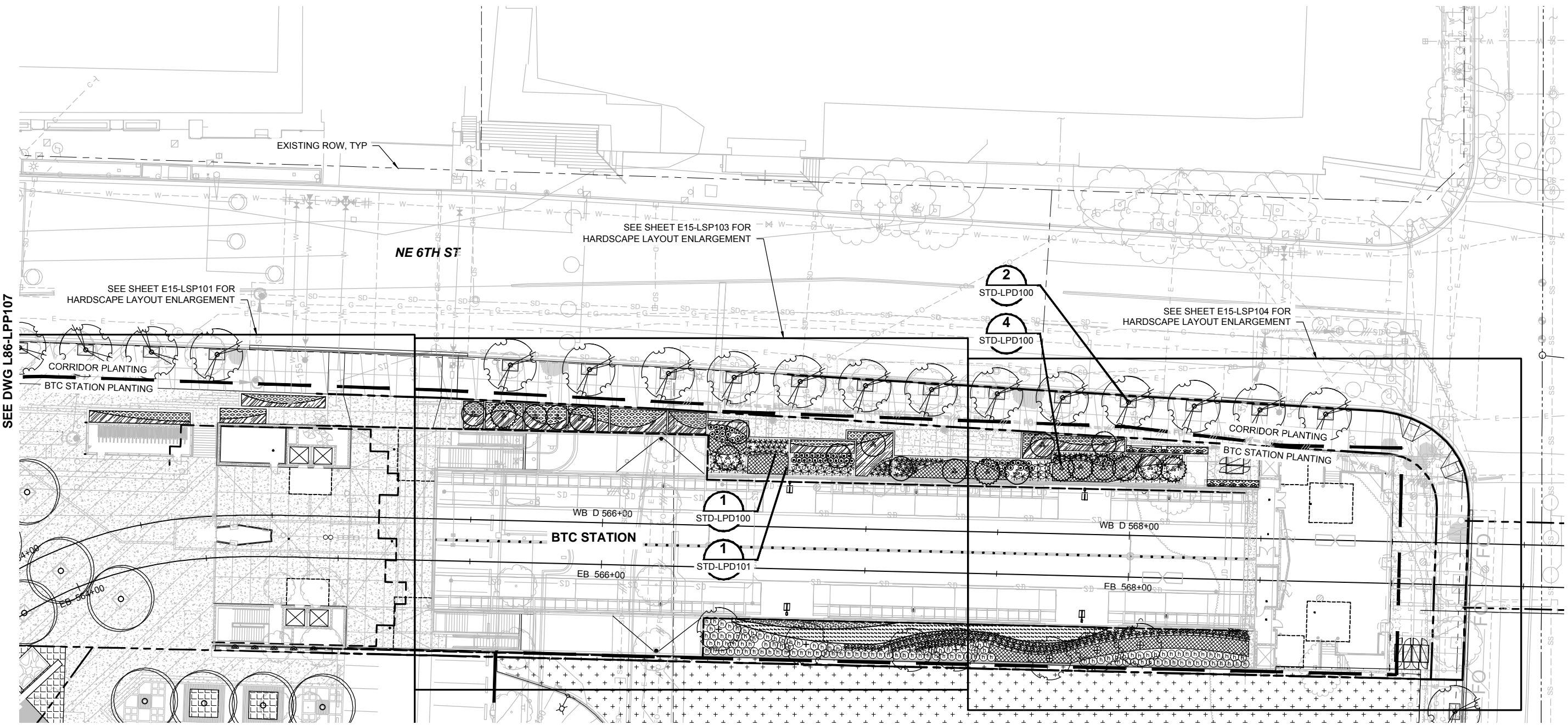

NOTES:
 1. SEE DWG L86-LPS100 FOR CORRIDOR PLANT SCHEDULE AND BTC STATION PLANT SCHEDULE.

SEE DWG L86-LPP143

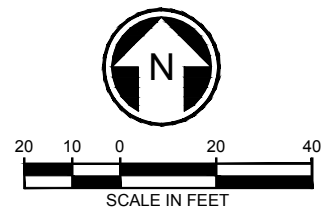

<h1 style="text-align: center;">60% SUBMITTAL</h1>					DESIGNED BY: J. YONG	 <small>STATE OF WASHINGTON LICENSED LANDSCAPE ARCHITECT</small> JULIET B. YONG LICENSE NO. 857 EXPIRES ON:	 <small>715 WEST LANE AVENUE NORTH SEATTLE, WA 98107 206.622.3333 JUNE 2006/02.0245 BX</small>	 FINAL DESIGN PARTNERS.	 SOUNDTRANSIT	SCALE: 1" = 20'	EAST LINK EXTENSION CONTRACT E335 DOWNTOWN BELLEVUE TO SPRING DISTRICT LANDSCAPE PLANTING PLAN CORRIDOR	DRAWING No.: L86-LPP108
					DRAWN BY: R. DOTSON					FILENAME: E335-L86-LPP108		LOCATION ID:
					CHECKED BY: D. KOONTS				CONTRACT No.: RTA/LR XXXX-XX	SHEET No.:	REV: 0	
					APPROVED BY: J. SCHUTT				DATE: 12/20/2013			
No.	DATE	DSN	CHK	APP	REVISION							

XREF LIST:
 XE335-L86-CAP100
 XE335-L86-CMP100
 XE335-L86-KAP100
 XE335-L86-LPP100
 XE335-L86-SFP100
 XE335-L86-CDP100
 XEL-0528r
 XEL-0528f
 XEL-0528t
 XE335-CB-TR22x34
 XE335-L86-RPP100
 XE335-L86-CRP100
 XE335-L86-CGP100
 XE335-E15-APP100
 XE335-L86-CLP100
 XE335-L86-CPP100
 XE335-L86-JCP100
 XE335-L86-JEP100
 GB-SEAL-JBVB57
 XE335-E15-LSP100
 XEL-0528g
 XE335-L86-GZV020

ORIGINATED BY: / DATE: /
 CHECKED BY: / DATE: /
 BACK-CHECKED BY: / DATE: /
 11/22/13 1:57 PM | CALDWELL
 C:\USERS\PUBLIC\DOCUMENTS\CALDWELL\HITTPS\SHAREPOINT\ SOUNDTRANSIT\ORG\443\SITES\CAD\EL\BEL\RED\E335\L86-LPP109.DWG

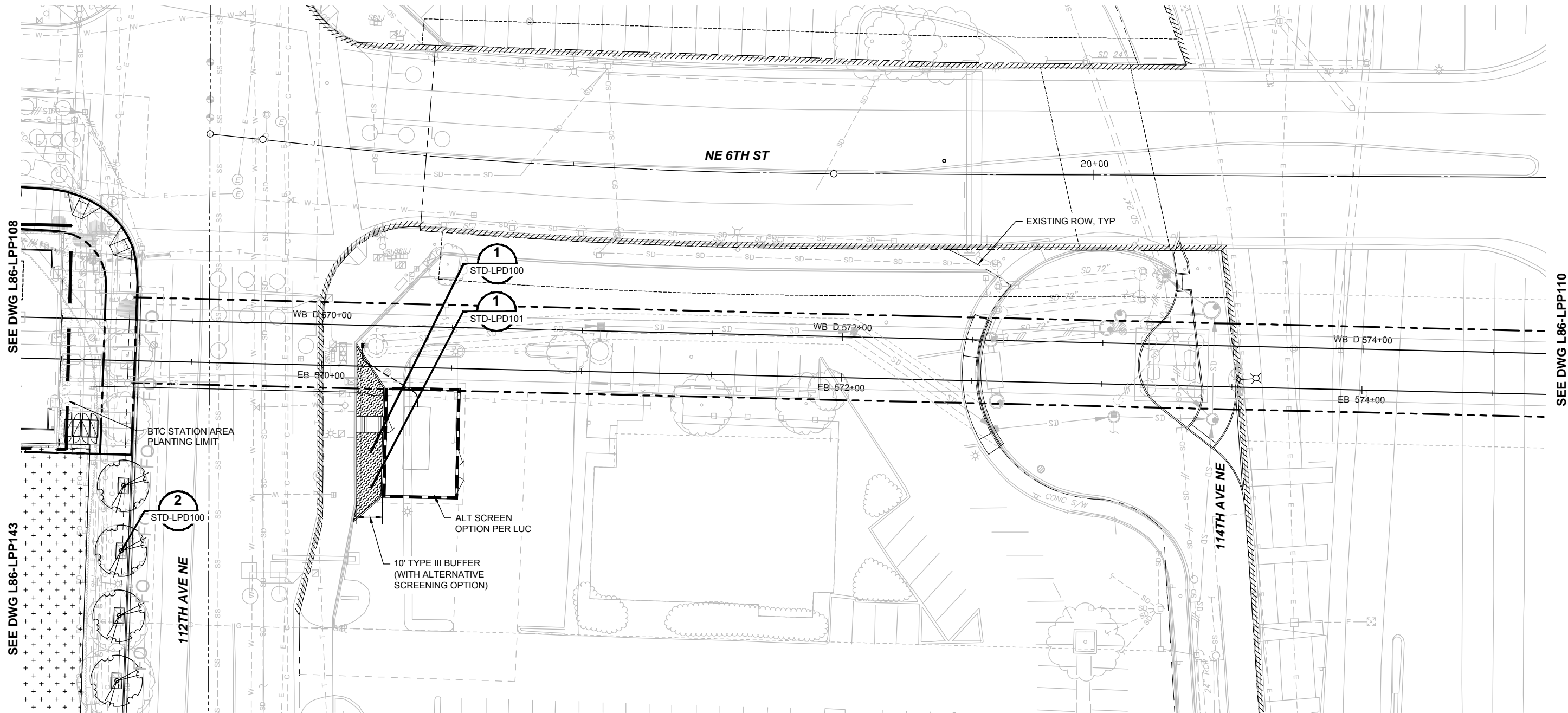

NOTES:
 1. SEE DWG L86-LPS100 FOR CORRIDOR PLANT SCHEDULE.

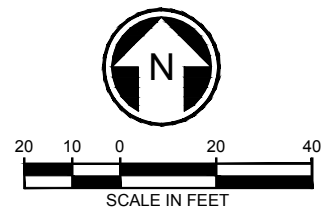

60% SUBMITTAL

DESIGNED BY:
J. VONG
 DRAWN BY:
R. DOTSON
 CHECKED BY:
D. KOONTS
 APPROVED BY:
J. SCHUTT

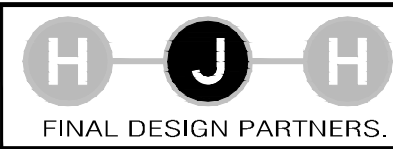

SCALE:
 1" = 20'
 FILENAME:
 E335-L86-LPP109
 CONTRACT No.:
 RTA/LR XXXX-XX
 DATE:
 12/20/2013

**EAST LINK EXTENSION
 CONTRACT E335**
 DOWNTOWN BELLEVUE TO SPRING DISTRICT
 LANDSCAPE
 PLANTING PLAN
 CORRIDOR

DRAWING No.:
L86-LPP109
 LOCATION ID:
 SHEET No.: REV:
 0

No.	DATE	DSN	CHK	APP	REVISION

XREF LIST:
 XE335-L86-CAP100
 XE335-L86-CMP100
 XE335-L86-KAP100
 XE335-L86-LPP100
 XE335-L86-SFP100
 XE335-L86-CDP100
 XEL-0528rx
 XEL-0528sf
 XEL-0528ut
 XE335-CB-TB22x34
 XE335-L86-RPP100
 XE335-L86-CRP100
 XE335-L86-CGP100
 XE335-L86-CLP100
 XE335-L86-CPP100
 XE335-L86-UCP100
 XE335-L86-EP100
 GB-SEAL-BV857
 XEL-0528vg

ORIGINATED BY: / DATE: /
 CHECKED BY: / DATE: /
 BACK-CHECKED BY: / DATE: /
 11/22/13 1:57 PM | CALDWELL
 C:\USERS\PUBLIC\DOCUMENTS\CALDWELL\HITTPS\SHAREPOINT\SOUNDTRANSIT\ORG\443\SITES\CAD\ELBEL\RED\E335-L86-LPP110.DWG

SEE DWG L86-LPP109

SEE DWG L86-LPP111

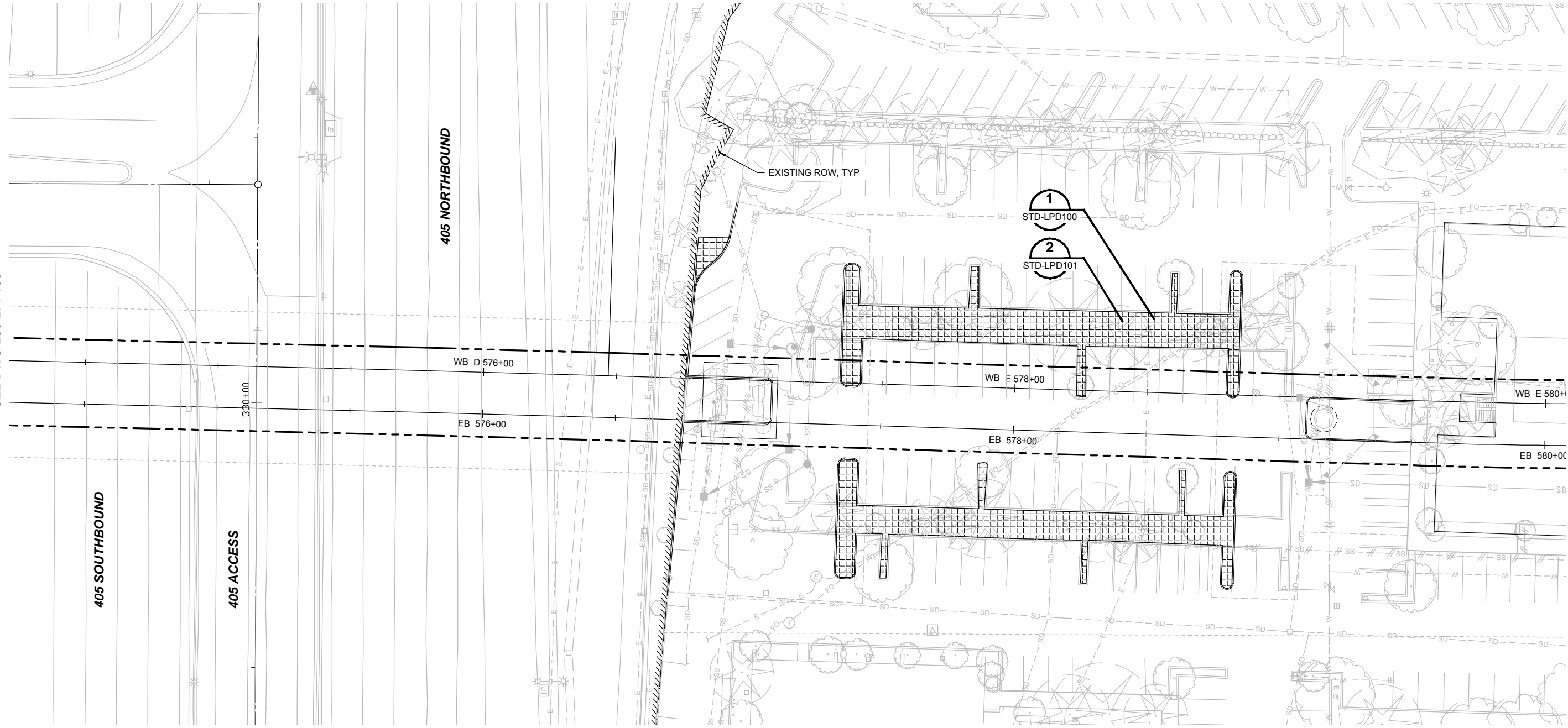

NOTES:
 1. SEE SHEET L86-LPS 100 FOR CORRIDOR PLANT SCHEDULE.

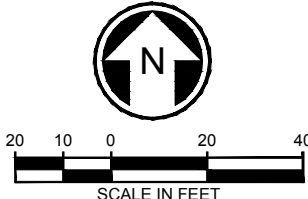

60% SUBMITTAL

DESIGNED BY:
J. VONG
 DRAWN BY:
R. DOTSON
 CHECKED BY:
D. KOONTS
 APPROVED BY:
J. SCHUTT



SCALE:
 1" = 20'
 FILENAME:
E335-L86-LPP110
 CONTRACT No.:
RTA/LR XXXX-XX
 DATE:
12/20/2013

**EAST LINK EXTENSION
 CONTRACT E335**
 DOWNTOWN BELLEVUE TO SPRING DISTRICT
 LANDSCAPE
 PLANTING PLAN
 CORRIDOR

DRAWING No.:
L86-LPP110
 LOCATION ID:
 SHEET No.: **REV:**
0

No.	DATE	DSN	CHK	APP	REVISION

XREF LIST:
 XE335-L86-CAP100
 XE335-L86-CMP100
 XE335-L86-KAP100
 XE335-L86-LPP100
 XE335-L86-SFP100
 XE335-L86-CDP100
 XEL-0528x
 XEL-0528f
 XEL-0528t
 XE335-08-TR22x34
 XE335-L86-RPP100
 XE335-L86-CRP100
 XE335-L86-CGP100
 XE335-L86-CLP100
 XE335-L86-CP100
 XE335-L86-UCP100
 XE335-L86-EP100
 GB-SEAL-BV857
 XEL-0528vg

ORIGINATED BY: / DATE: /
 CHECKED BY: / DATE: /
 BACK-CHECKED BY: / DATE: /
 11/22/13 1:58 PM | CALDWELL
 C:\USERS\PUBLIC\DOCUMENTS\CALDWELL\HITTPS\SHAREPOINT\SOUNDTRANSIT\ORG\443\SITES\CAD\EL\RED\E335-L86-LPP111.DWG

CORRECTED BY: / DATE: /
 VERIFIED BY: / DATE: /

SEE DWG L86-LPP110

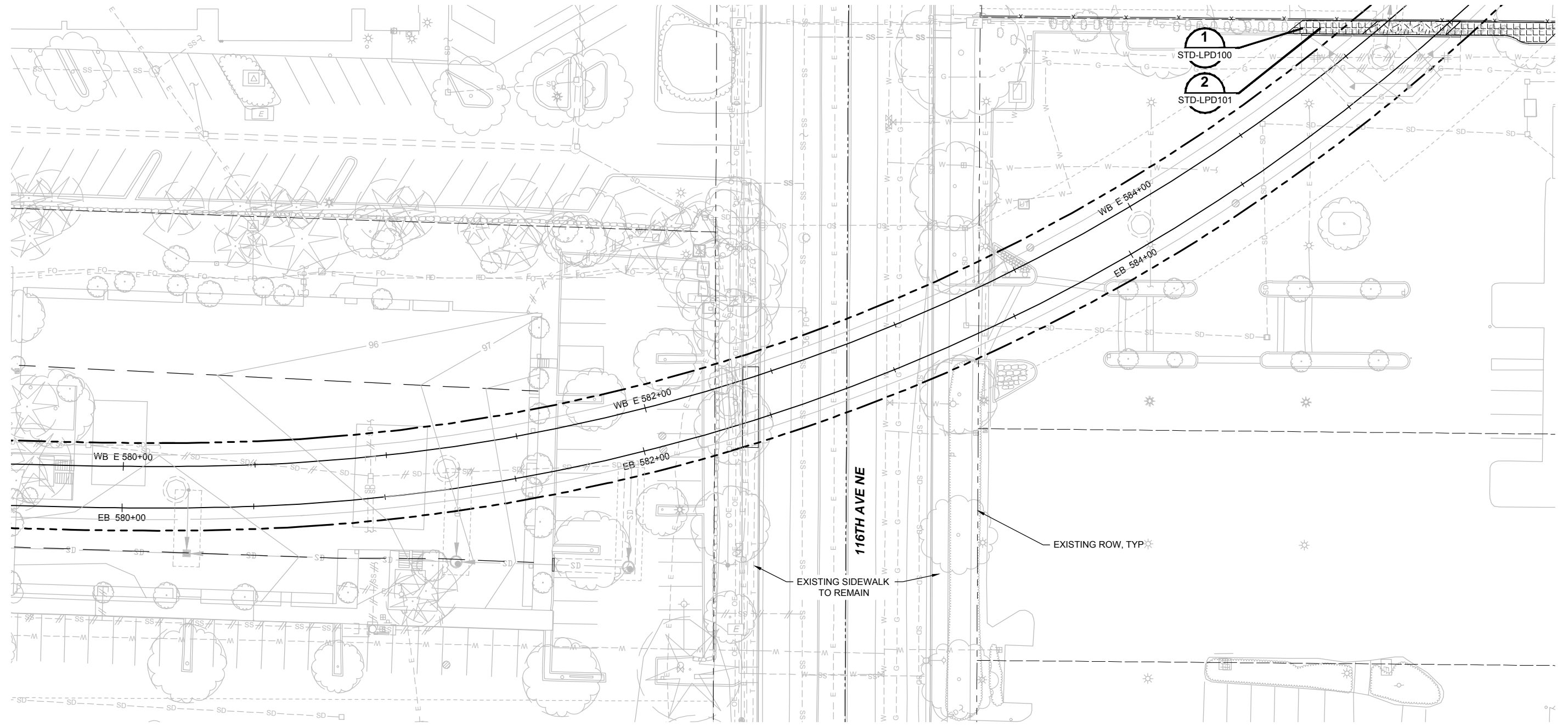

SEE DWG L86-LPP144

SEE DWG L86-LPP112

- NOTES:**
- SEE DWG L86-LPS 100 FOR CORRIDOR PLANT SCHEDULE.

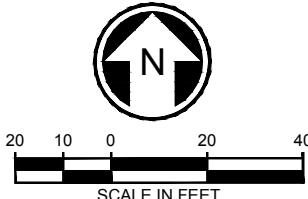

60% SUBMITTAL					
No.	DATE	DSN	CHK	APP	REVISION

DESIGNED BY:
J. YONG
 DRAWN BY:
R. DOTSON
 CHECKED BY:
D. KOONTS
 APPROVED BY:
J. SCHUTT

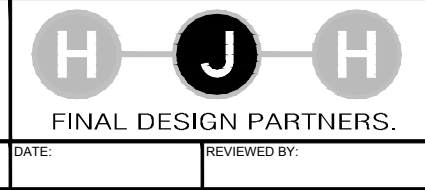
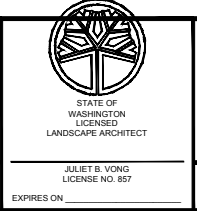

SCALE:
1" = 20'
 FILENAME:
E335-L86-LPP111
 CONTRACT No.:
RTA/LR XXXX-XX
 DATE:
12/20/2013

**EAST LINK EXTENSION
 CONTRACT E335**
 DOWNTOWN BELLEVUE TO SPRING DISTRICT

LANDSCAPE
 PLANTING PLAN
 CORRIDOR

DRAWING No.:
L86-LPP111
 LOCATION ID:
 SHEET No.:
REV:
0

SEE DWG L86-LPP111

SEE DWG L86-LPP144

- XREF LIST:**
- XE335-E19-APP100
 - XE335-E19-SFP100
 - XE335-E19-SGP100
 - XE335-L86-CAP100
 - XE335-L86-CMP100
 - XE335-L86-KAP100
 - XE335-L86-LPP100
 - XE335-L86-SFP100
 - XE335-L86-CDP100
 - XEL-0528x
 - XEL-0528f
 - XEL-0528u
 - XE335-L86-RFP100
 - XE335-GB-TB22x34
 - XE335-L86-CRP100
 - XE335-L86-CPP100
 - XE335-L86-EP100
 - XE335-L86-CLP100
 - XE335-L86-CPP100
 - XE335-L86-UCP100
 - GB-SEAL-BV857
 - XEL-0528vg

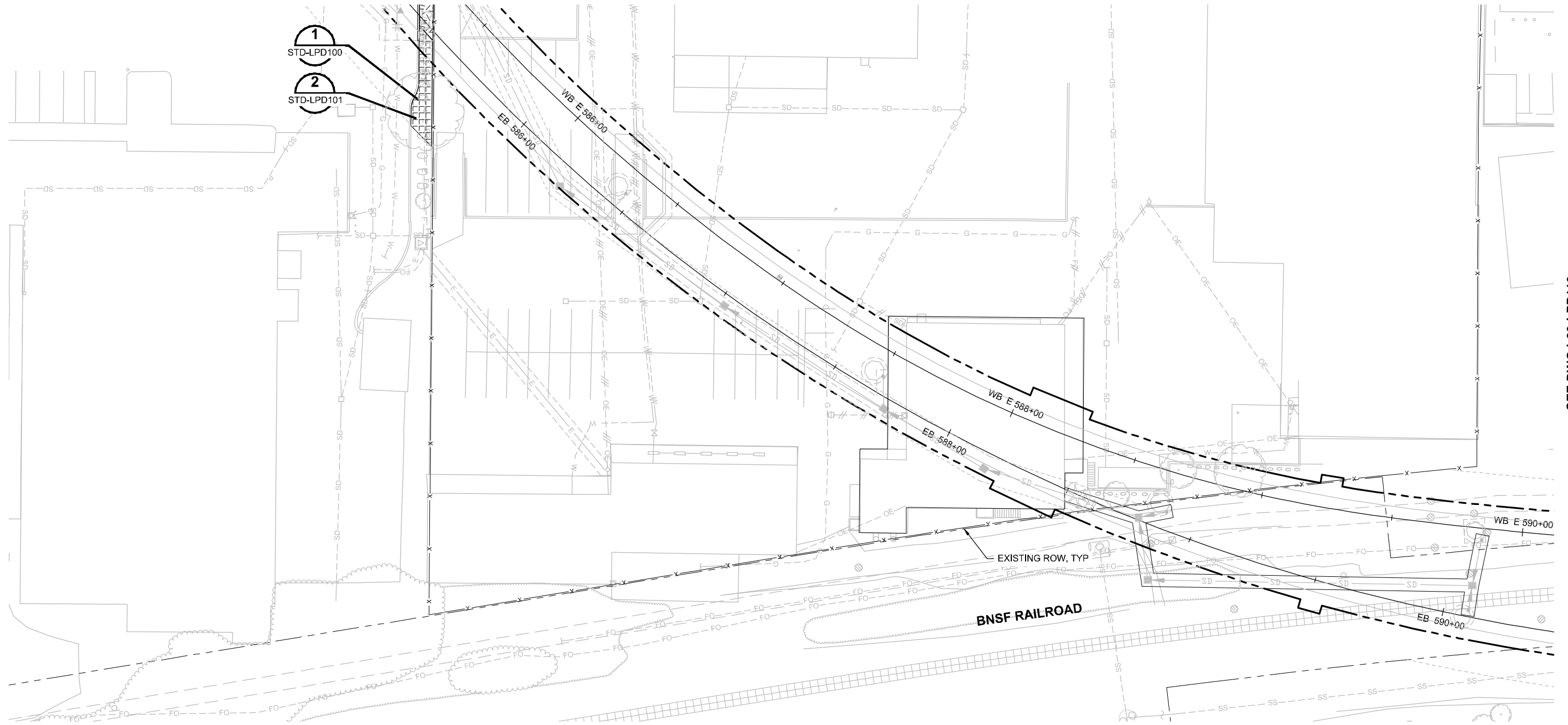

SEE DWG L86-LPP113

NOTES:

1. SEE DWG L86-LPS100 FOR CORRIDOR PLANT SCHEDULE.

ORIGINATED BY: / DATE: /
 CHECKED BY: / DATE: /
 BACK-CHECKED BY: / DATE: /
 11/22/13 1:58 PM | CALDWELL
 C:\USERS\PUBLIC\DOCUMENTS\CALDWELL\H\TTPS\SHAREPOINT\SOUNDTRANSIT\ORG\443\SITES\CAD\EL\BEL\RED\E335\L86-LPP112.DWG

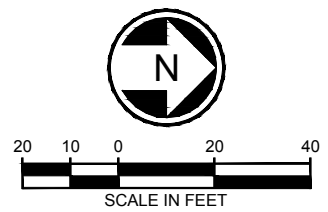

60% SUBMITTAL

DESIGNED BY:
J. VONG

DRAWN BY:
R. DOTSON

CHECKED BY:
D. KOONTS

APPROVED BY:
J. SCHUTT

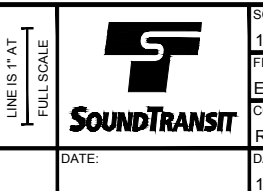
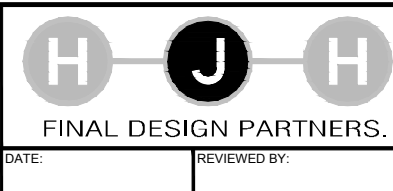

SCALE:
1" = 20'

FILENAME:
E335-L86-LPP112

CONTRACT No.:
RTA/LR XXXX-XX

DATE:
12/20/2013

**EAST LINK EXTENSION
CONTRACT E335**

DOWNTOWN BELLEVUE TO SPRING DISTRICT

LANDSCAPE
PLANTING PLAN
CORRIDOR

DRAWING No.:
L86-LPP112

LOCATION ID:

SHEET No.: REV:
0

No.	DATE	DSN	CHK	APP	REVISION

XREF LIST:
 XE335-L86-CAP100
 XE335-L86-CMP100
 XE335-L86-KAP100
 XE335-L86-LPP100
 XE335-L86-SFP100
 XE335-L86-CDF100
 XE335-L86-RPP100
 XE335-GB-TB22x34
 XE335-L86-CRP100
 XE335-L86-CDF100
 XE335-E19-LPP100
 XE335-E19-LSP100
 XE335-L86-CLP100
 XE335-L86-UCP100
 XE335-L86-JEP100
 XE335-L86-CPP100
 XE335-E19-APP100
 GB-SEAL_BV857
 XE335-L86-LMP100
 XE335-L86-GZV020
 XEL-0528af
 XEL-0528at
 XEL-0528av
 XEL-0528rv
 XEL-0531rx
 XEL-0531rf
 XEL-0531af
 XEL-0531vg
 XE335-E19-ELP100

ORIGINATED BY: / DATE: /
 CHECKED BY: / DATE: /
 BACK-CHECKED BY: / DATE: /
 11/22/13 1:59 PM | CALDWELL
 C:\USERS\PUBLIC\DOCUMENTS\CALDWELL\HITTPS\SHAREPOINT\SOUNDTRANSIT\ORG\443\SITES\CAD\EL\BEL\RED\E335\L86-LPP113.DWG

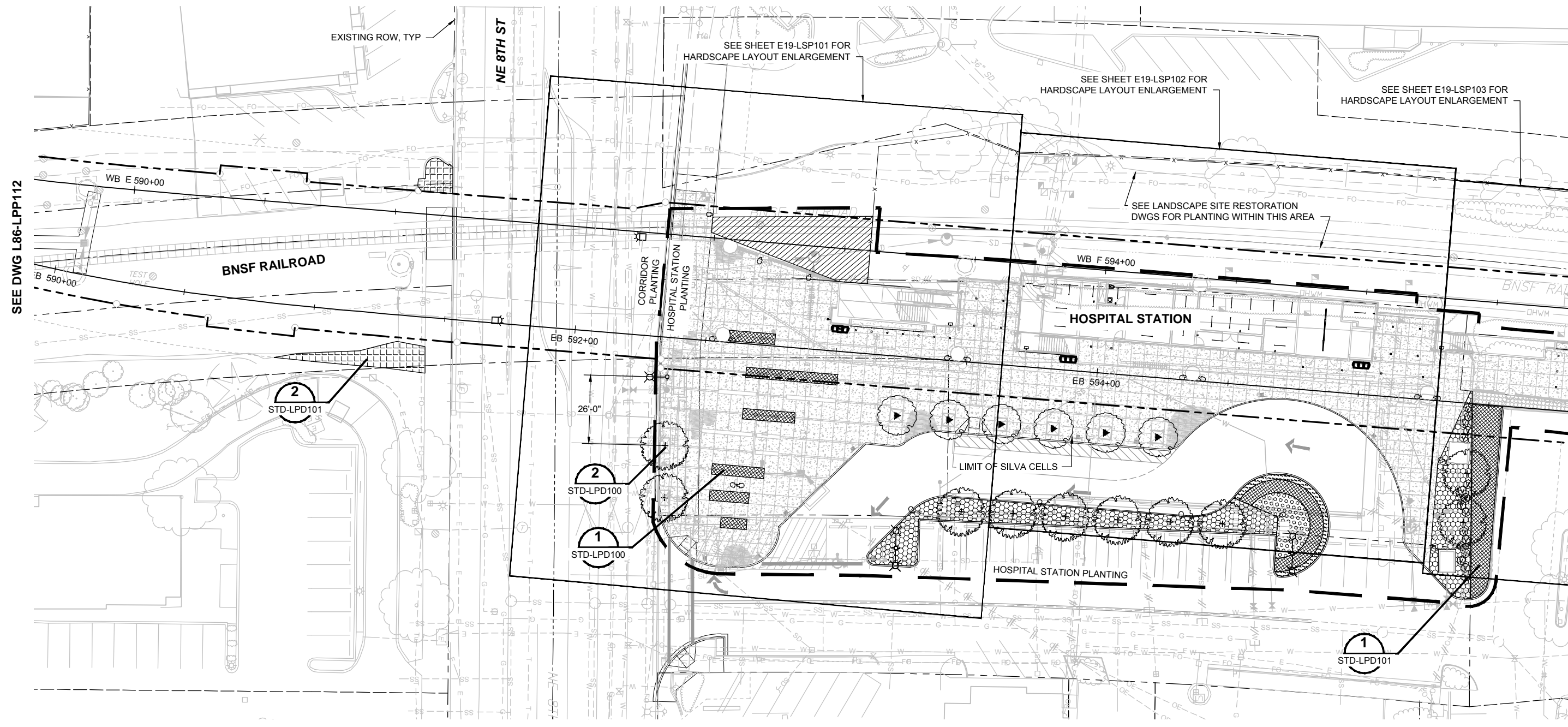

- NOTES:**
- SEE DWG L86-LPS100 FOR CORRIDOR PLANT SCHEDULE.
 - SEE DWG L86-LPS102 FOR HOSPITAL STATION PLANT SCHEDULE.

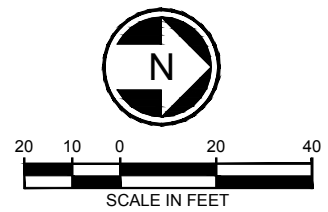

60% SUBMITTAL

DESIGNED BY:
J. YONG
 DRAWN BY:
R. DOTSON
 CHECKED BY:
D. KOONTS
 APPROVED BY:
J. SCHUTT

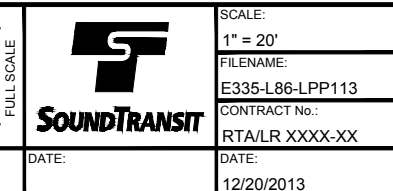

SCALE:
1" = 20'
 FILENAME:
E335-L86-LPP113
 CONTRACT No.:
RTA/LR XXXX-XX
 DATE:
12/20/2013

**EAST LINK EXTENSION
 CONTRACT E335**
 DOWNTOWN BELLEVUE TO SPRING DISTRICT

LANDSCAPE
 PLANTING PLAN
 CORRIDOR

DRAWING No.:
L86-LPP113
 LOCATION ID:
 SHEET No.: REV:
 0

XREF LIST:
 XE330-E15-SFP400
 XE335-L86-CAP100
 XE335-L86-CMP100
 XE335-L86-KAP100
 XE335-L86-LPP100
 XE335-L86-SFP100
 XE335-L86-CDP100
 XEL-0531rx
 XEL-0531M
 XEL-0531st
 XE335-L86-RPP100
 XE335-GB-TB22x34
 XE335-L86-CRP100
 XE335-L86-CGP100
 XE335-E19-LSP100
 XE335-E19-LPP100
 XE335-L86-JCR100
 XE335-L86-JEP100
 XE335-L86-CLP100
 XE335-L86-CPP100
 XE335-E19-APP100
 GB-SEAL-JBV857
 XE335-L86-LMP100
 XEL-0531vg
 XE335-E15-ELP100
 XE335-E19-ELP100

ORIGINATED BY: / DATE: /
 CHECKED BY: / DATE: /
 CORRECTED BY: / DATE: /
 VERIFIED BY: / DATE: /
 11/22/13 | 2:00 PM | CALDWELL
 C:\USERS\PUBLIC\DOCUMENTS\CALDWELL\PROJECTS\SHAREPOINT_SOUNDTRANSIT\ORG\443\SITES\CAD\EL\BEL\RED\E335\L86-LPP114.DWG

SEE DWG L86-LPP113

SEE DWG L86-LPP145

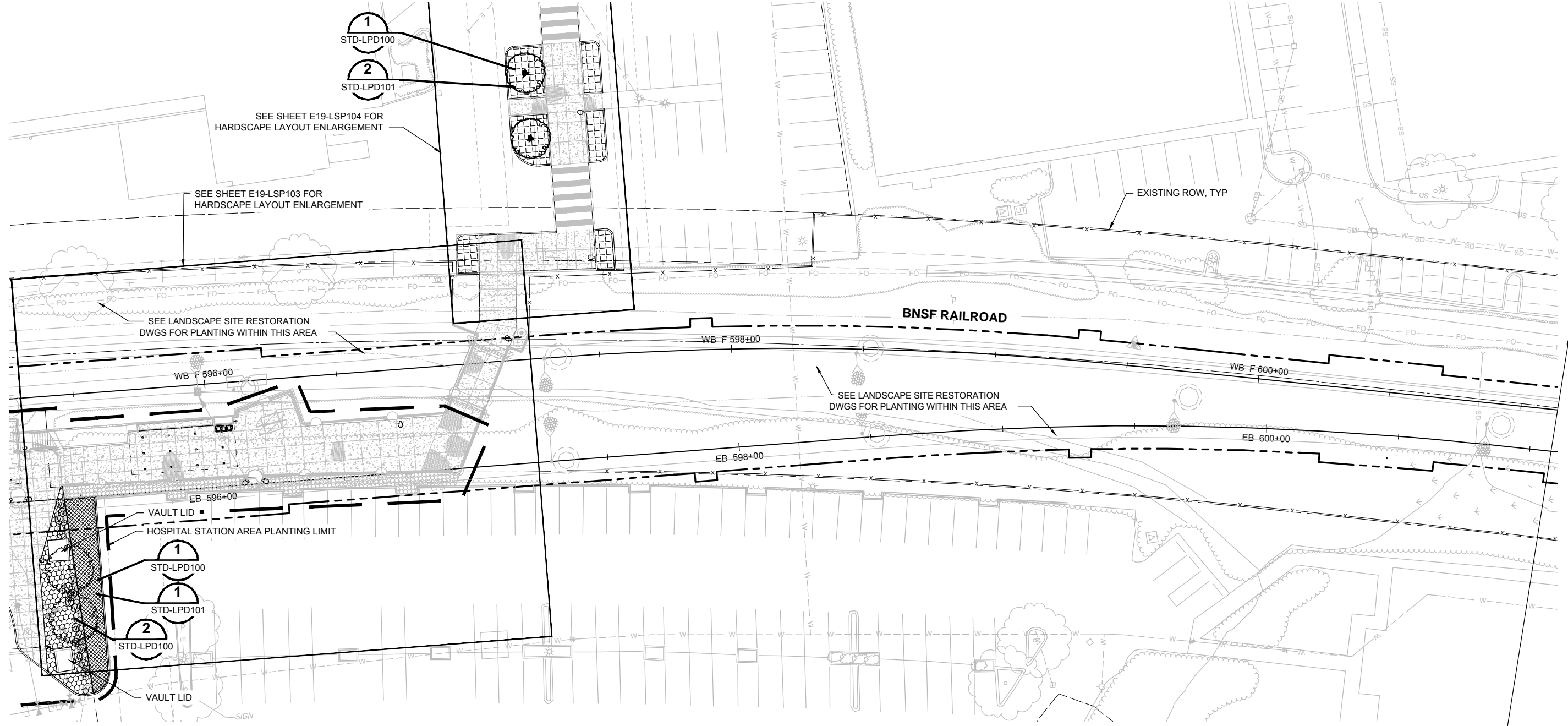

- NOTES:**
- SEE DWG L86-LPS100 FOR CORRIDOR PLANT SCHEDULE.
 - SEE DWG L86-LPS102 FOR HOSPITAL STATION PLANT SCHEDULE.

Note to Reviewer: This is the eastern limit of design included in this 60% submittal. Design east of this location was previously submitted and reviewed as part of the Contract E340 60% submittal, dated July 15, 2013. Review comments associated with design east of this location have not been incorporated but will be addressed during 90% design.

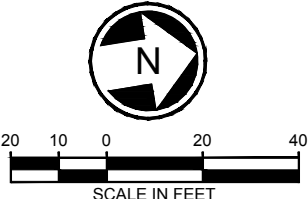

60% SUBMITTAL

DESIGNED BY:
J. YONG
 DRAWN BY:
R. DOTSON
 CHECKED BY:
D. KOONTS
 APPROVED BY:
J. SCHUTT



SCALE:
1" = 20'
 FILENAME:
E335-L86-LPP114
 CONTRACT No.:
RTA/LR XXXX-XX
 DATE:
12/20/2013

**EAST LINK EXTENSION
 CONTRACT E335**
 DOWNTOWN BELLEVUE TO SPRING DISTRICT
 LANDSCAPE
 PLANTING PLAN
 CORRIDOR

DRAWING No.:
L86-LPP114
 LOCATION ID:
 SHEET No.: REV:
0

No.	DATE	DSN	CHK	APP	REVISION

XREF LIST:
 XE335-L86-CAP100
 XE335-L86-CMP100
 XE335-L86-KAP100
 XE335-L86-LPP100
 XE335-L86-SFP100
 XE335-L86-CDP100
 XEL-0525rx
 XEL-0525sf
 XEL-0525ut
 XEL-0528rx
 XEL-0528sf
 XEL-0528ut
 XE330-L86-KAP100
 XE335-GB-TB22x34
 XE335-L86-CGP100
 XE335-E11-APP100
 XE330-L86-CRP100
 XE335-E11-LSP100
 XE335-L86-CLP100
 XE335-L86-CPP100
 XE335-L86-UCP100
 XE335-L86-JEP100
 XE335-E11-LPP100
 XE335-L86-CRP100
 GB-SEAL-BV857
 XE335-L86-LPP101
 XE335-L86-SP101
 XE330-T86-STP002
 XE330-T86-STP001
 XE335-L86-SWP100
 XE330-T86-SWP100
 XE330-T86-CRP100
 XE335-L86-APP100
 XE335-L86-ASP100
 XEL-0528rv
 XE335-L86-RPP100
 XE335-L86-GZV020
 XE335-L86-LTP100

ORIGINATED BY: / DATE: /
 CHECKED BY: / DATE: /
 BACK-CHECKED BY: / DATE: /
 11/28/13 | 3:10 PM | CALDWELL
 C:\USERS\PUBLIC\DOCUMENTS\CALDWELL\H\H\TTPS\SHAREPOINT\SOUNDTRANSIT\ORG\443\SITES\AD\EL\BEL\RED\E335\L86-LPP141.DWG

SEE DWG L86-LPP101

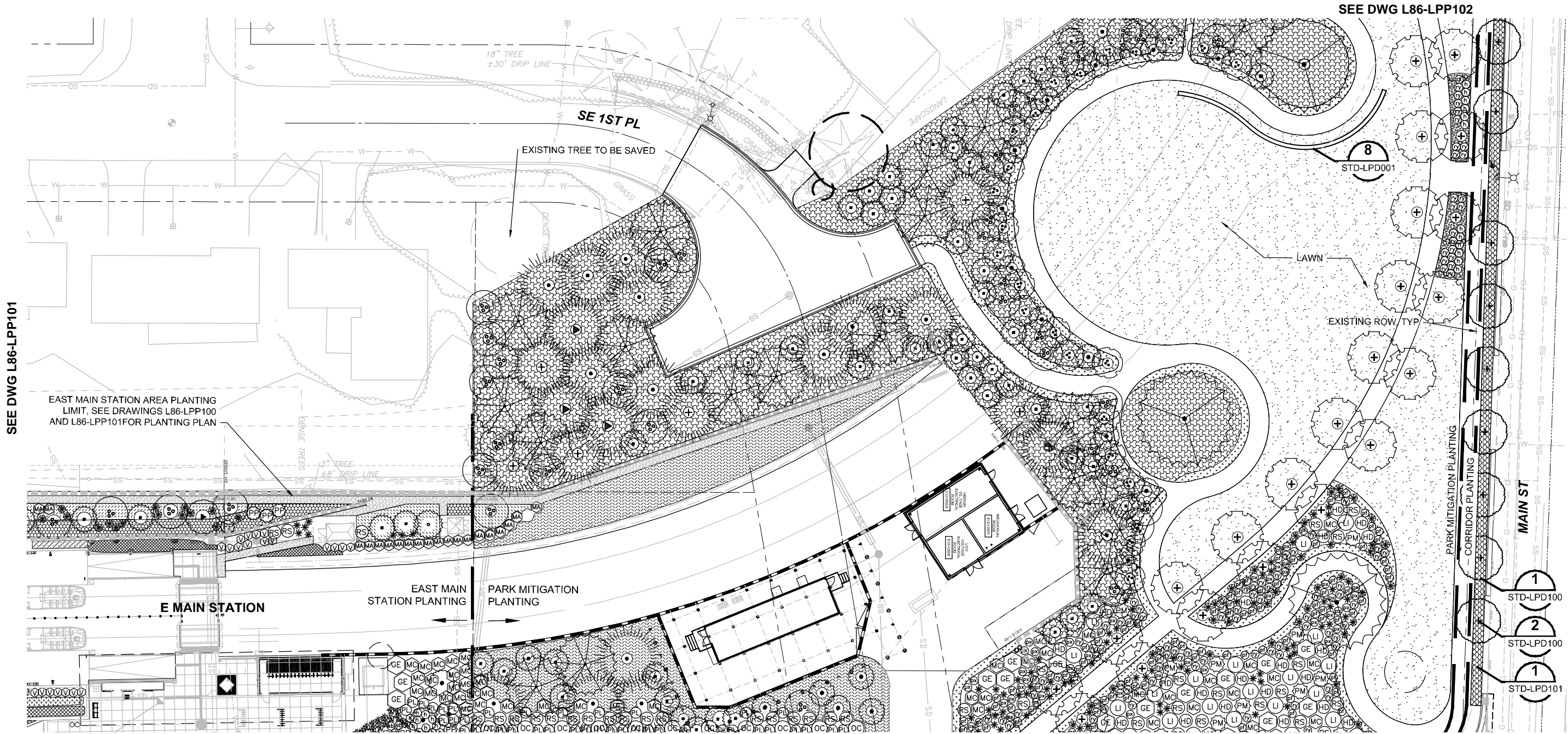

- NOTES:**
- SEE DWG L86-LPS100 FOR CORRIDOR PLANT SCHEDULE.
 - SEE DWG L86-LPS101 FOR EAST STATION PLANT SCHEDULE.
 - SEE DWG L86-LPS103 FOR PARK MITIGATION PLANT SCHEDULE.

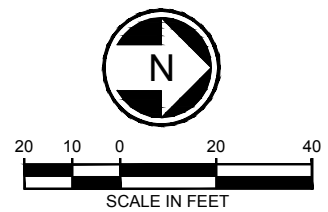

60% SUBMITTAL

DESIGNED BY:
J. YONG
 DRAWN BY:
R. DOTSON
 CHECKED BY:
D. KOONTZ
 APPROVED BY:
J. SCHUTT

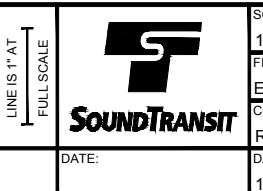
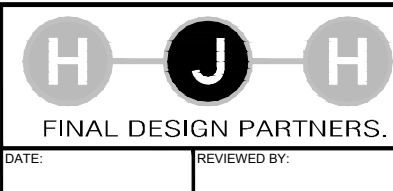

SCALE:
 1" = 20'
 FILENAME:
 E335-L86-LPP141
 CONTRACT No.:
 RTA/LR XXXX-XX
 DATE:
 12/20/2013

**EAST LINK EXTENSION
 CONTRACT E335**
 DOWNTOWN BELLEVUE TO SPRING DISTRICT
 LANDSCAPE
 PLANTING PLAN
 CORRIDOR

DRAWING No.:
L86-LPP141
 LOCATION ID:
 SHEET No.: REV:
 0

XREF LIST:
 XE335-L86-CAP100
 XE335-L86-CMP100
 XE335-L86-KAP100
 XE335-L86-LPP100
 XE335-L86-SFP100
 XE335-L86-CDP100
 XEL-0228r
 XEL-0228f
 XEL-0228u
 XEL-0528r
 XEL-0528f
 XEL-0528u
 XE335-03-TR22x34
 XE335-L86-RPP100
 XE335-L86-CRP100
 XE335-L86-CPP100
 XE335-L86-APP100
 XE335-E15-LPP100
 XE335-E15-LSP100
 XE335-E15-APP100
 XE335-L86-CLP100
 XE335-L86-CPP100
 XE335-L86-UCP100
 XE335-L86-SEP100
 GB-SEAL-BV857
 XEL-E00-SHT-MS1R

ORIGINATED BY: / DATE: /
 CHECKED BY: / DATE: /
 BACK-CHECKED BY: / DATE: /
 11/22/13 | 2:05 PM | CALDWELL
 C:\USERS\PUBLIC\DOCUMENTS\CALDWELL\H\TTPS\SHAREPOINT\SOUNDTRANSIT\ORG\443\SITES\CAD\EL\BEL\RED\E335-L86-LPP143.DWG

SEE DWG L86-LPP108

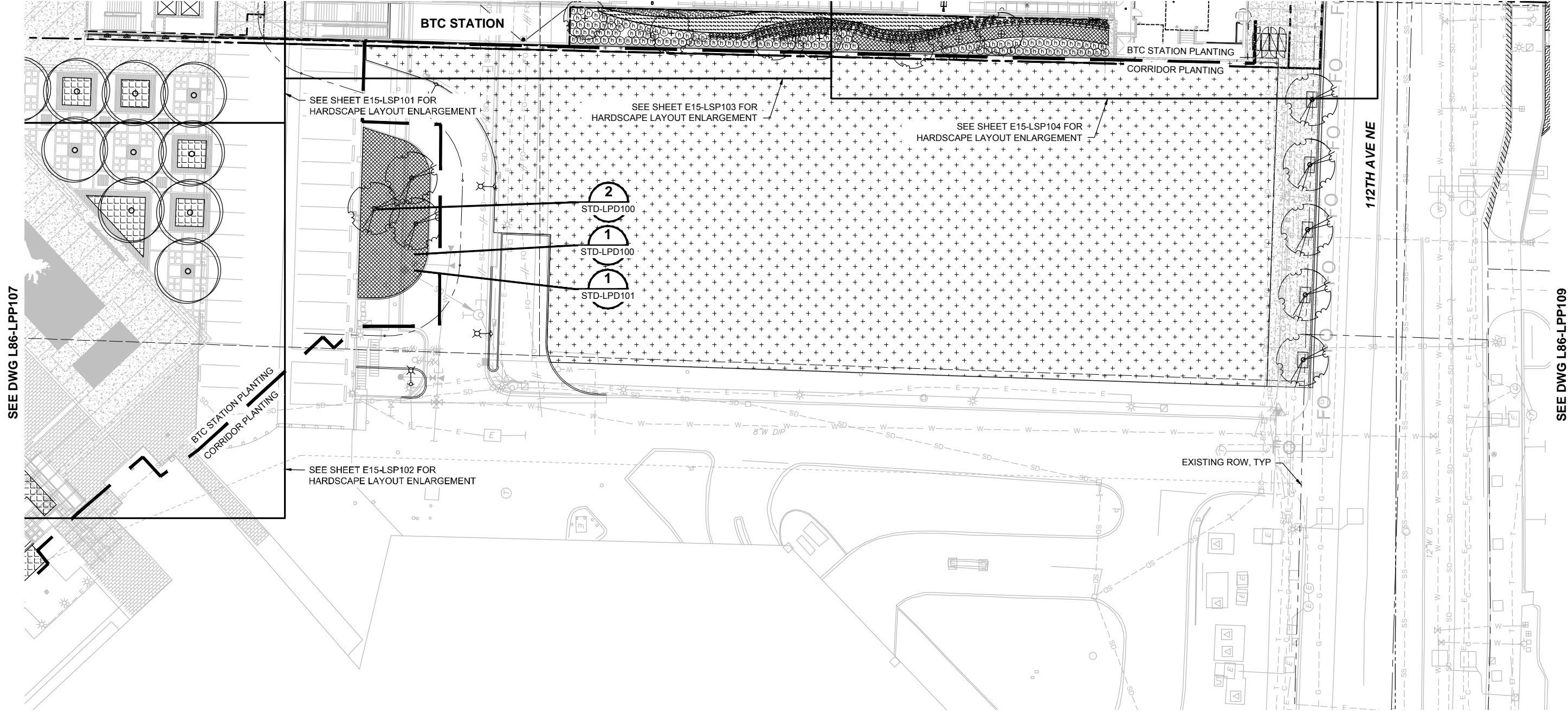

- NOTES:**
- SEE DWG L86-LPS100 FOR CORRIDOR PLANT SCHEDULE AND BTC STATION PLANT SCHEDULE.

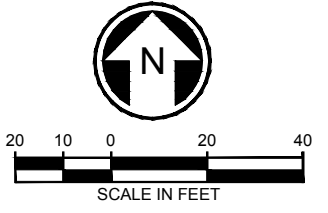

60% SUBMITTAL

DESIGNED BY:
J. YONG
 DRAWN BY:
R. DOTSON
 CHECKED BY:
D. KOONTS
 APPROVED BY:
J. SCHUTT

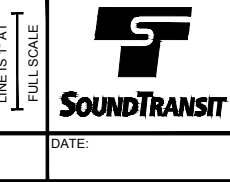

SCALE:
1" = 20'
 FILENAME:
E335-L86-LPP143
 CONTRACT No.:
RTA/LR XXXX-XX
 DATE:
12/20/2013

**EAST LINK EXTENSION
 CONTRACT E335**
 DOWNTOWN BELLEVUE TO SPRING DISTRICT
 LANDSCAPE
 PLANTING PLAN
 CORRIDOR

DRAWING No.:
L86-LPP143
 LOCATION ID:
 SHEET No.: REV:
0

XREF LIST:
 XE335-L86-CAP100
 XE335-L86-CMP100
 XE335-L86-KAP100
 XE335-L86-LPP100
 XE335-L86-SFP100
 XE335-L86-CDP100
 XEL-0528r
 XEL-0528f
 XEL-0529r
 XEL-0531r
 XEL-0531f
 XEL-0531t
 XE335-08-1822x34
 XE335-L86-RPP100
 XE335-L86-CRP100
 XE335-L86-CP100
 XE335-L86-CLP100
 XE335-L86-CPP100
 XE335-L86-UCP100
 XE335-L86-HP100
 GB-SEAL-BV857

ORIGINATED BY: / DATE: /
 CHECKED BY: / DATE: /
 BACK-CHECKED BY: / DATE: /
 11/22/13 | 2:06 PM | CALDWELL
 C:\USERS\PUBLIC\DOCUMENTS\CALDWELL\HITTPS\SHAREPOINT\ SOUNDTRANSIT\ORG\443\SITES\CAD\EL\BEL\RED\E335-L86-LPP144.DWG

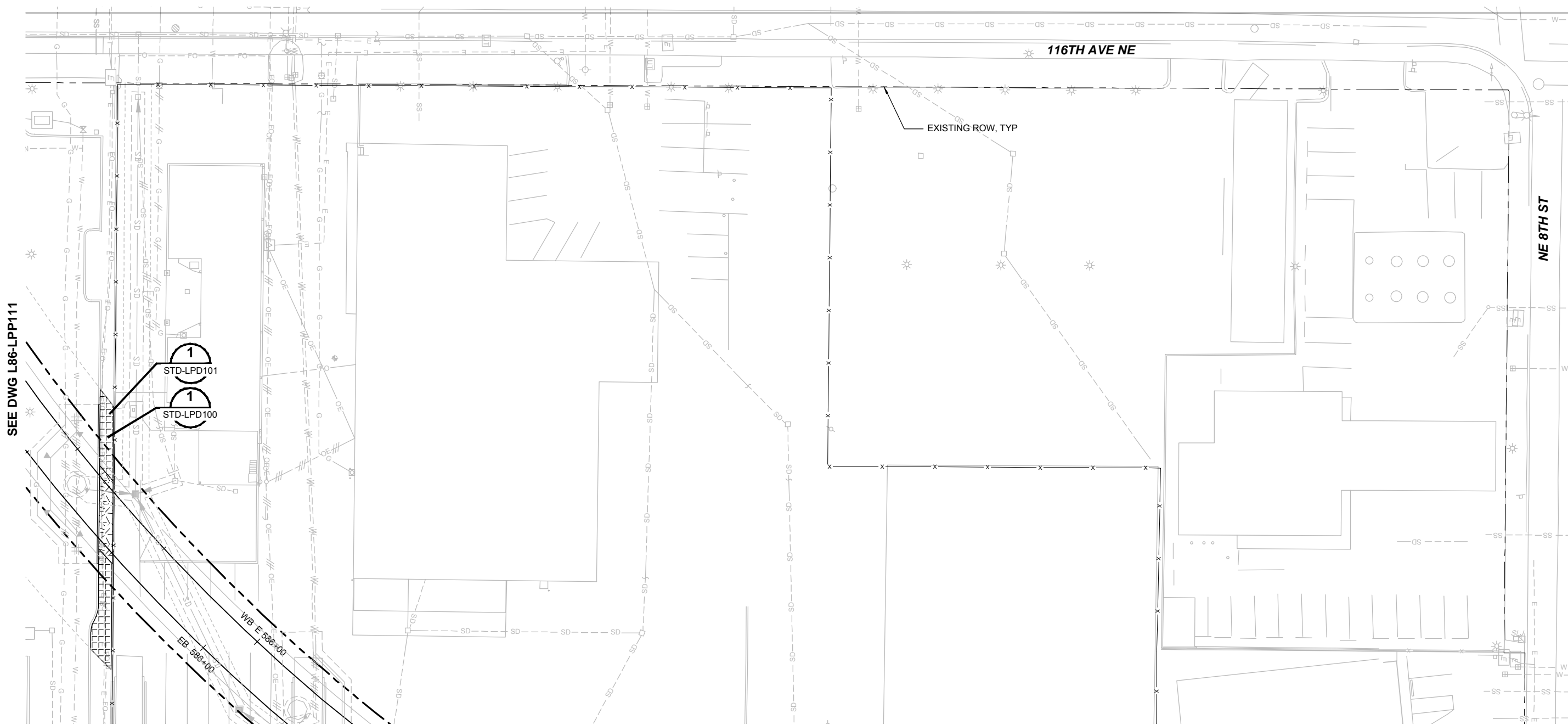

NOTES:
 1. SEE DWG L86-LPS100 FOR CORRIDOR PLANT SCHEDULE.

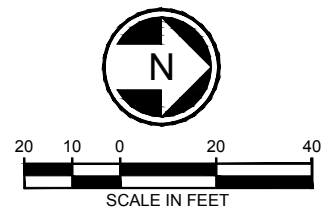

60% SUBMITTAL

DESIGNED BY:
J. VONG
 DRAWN BY:
R. DOTSON
 CHECKED BY:
D. KOONTS
 APPROVED BY:
J. SCHUTT

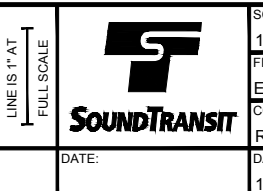
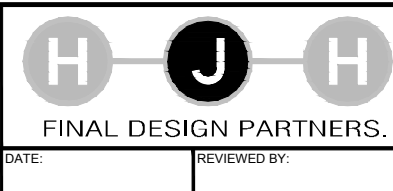

SCALE:
 1" = 20'
 FILENAME:
E335-L86-LPP144
 CONTRACT No.:
RTA/LR XXXX-XX
 DATE:
12/20/2013

**EAST LINK EXTENSION
 CONTRACT E335**
 DOWNTOWN BELLEVUE TO SPRING DISTRICT
 LANDSCAPE
 PLANTING PLAN
 CORRIDOR

DRAWING No.:
L86-LPP144
 LOCATION ID:
 SHEET No.: **REV:**
0

No.	DATE	DSN	CHK	APP	REVISION

XREF LIST:
 XE335-E19-APP100
 XE335-E19-SFP100
 XE335-E19-SGP100
 XE335-L86-CAP100
 XE335-L86-CMP100
 XE335-L86-KAP100
 XE335-L86-LPP100
 XE335-L86-SFP100
 XE335-L86-CDP100
 XE335-L86-LMP100
 XE335-L86-RPP100
 XE335-L86-CP100
 XE335-L86-UCP100
 XE335-L86-SEP100
 XE335-E19-LSP100
 GB-SEAL-JBV857
 XE335-L86-LMP100

ORIGINATED BY: / DATE: /
 CHECKED BY: / DATE: /
 BACK-CHECKED BY: / DATE: /
 11/22/13 | 2:06 PM | CALDWELL
 C:\USERS\PUBLIC\DOCUMENTS\CALDWELL\H\TTPS\SHAREPOINT\SOUNDTRANSIT\ORG\443\SITES\CAD\EL\BEL\RED\E335\L86\LPP145.DWG

CORRECTED BY: / DATE: /
 VERIFIED BY: / DATE: /

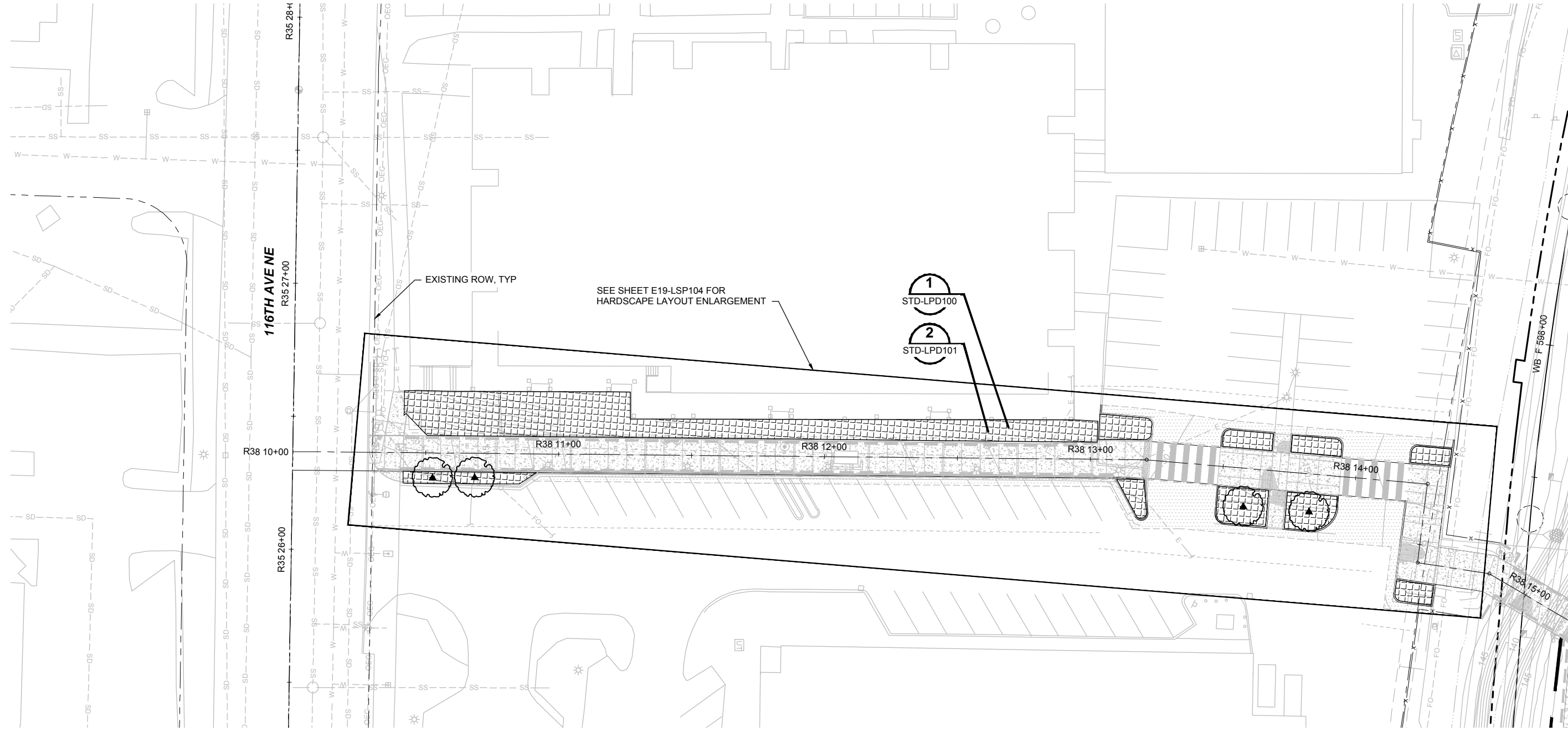

SEE DWG L86-LPP114

NOTES:
 1. SEE DWG L86-LPS100 FOR CORRIDOR PLANT SCHEDULE.

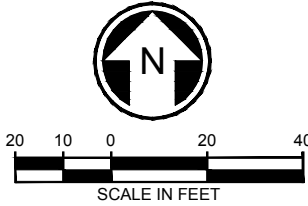

60% SUBMITTAL

DESIGNED BY:
J. YONG
 DRAWN BY:
R. DOTSON
 CHECKED BY:
D. KOONTS
 APPROVED BY:
J. SCHUTT



SCALE:
 1" = 20'
 FILENAME:
E335-L86-LPP145
 CONTRACT No.:
RTA/LR XXXX-XX
 DATE:
12/20/2013

**EAST LINK EXTENSION
 CONTRACT E335**
 DOWNTOWN BELLEVUE TO SPRING DISTRICT
 LANDSCAPE
 PLANTING PLAN
 CORRIDOR

DRAWING No.:
L86-LPP145
 LOCATION ID:
 SHEET No.:
 REV:
0

No.	DATE	DSN	CHK	APP	REVISION

XREF LIST:
 XE335-E11-APP100
 XEL-0525x
 XEL-0528x
 XE335-GB-TB22x34
 XE335-L86-KAP100
 XE335-L86-CMP100
 XE335-L86-CRP100
 XE335-E11-LSP100
 XEL-0528f
 XEL-0525f
 XE335-L86-SWP100
 XE335-L86-JEP100
 XE335-L86-JCP100
 GB-SEAL_FJN2241

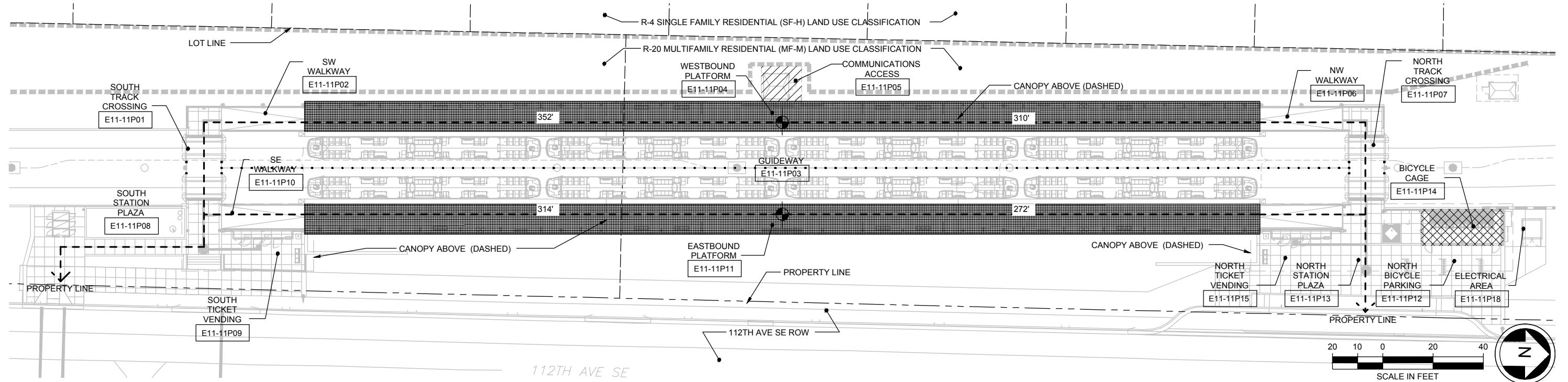

MUNICIPAL CODE INFORMATION - PLAN

SCALE: 1" = 20'-0"

1
E11-AAP001

MUNICIPAL CODE SUMMARY

BUILDING DESCRIPTION:

THE PROJECT IS LOCATED IN THE SOUTHWEST BELLEVUE SUBAREA ON THE WEST SIDE OF 112TH AVENUE SE BETWEEN SE 1ST PLACE AND SE 4TH ST. THE PROJECT IS AN OPEN, AT-GRADE LIGHT RAIL STATION WHICH INCLUDES TWO ENTRY PLAZAS. THE PLAZAS LEAD TO THE EASTBOUND PLATFORM WALKWAYS AND TO AT-GRADE TRACK CROSSINGS TO THE WESTBOUND PLATFORM. TICKETING OCCURS AT BOTH PLAZAS. THE TRAIN WAITING PLATFORMS OCCUR BEYOND THE TICKETING AREAS ON BOTH SIDES OF THE TRAIN GUIDEWAY.

APPLICABLE CODES:

2012 BELLEVUE BUILDING CODE (CHAPTER 23.10 OF BELLEVUE CITY CODE)
 2012 BELLEVUE LAND USE CODE (TITLE 20 OF BELLEVUE CITY CODE)
 2012 WASHINGTON STATE ENERGY CODE (WAC 51-11)
 2010 NFPA 130 W/ BELLEVUE AMENDMENTS
 2009 ICC/ANSI A 117.1 ACCESSIBLE AND USABLE BUILDINGS AND FACILITIES

ZONING: R-20 MULTI-FAMILY RESIDENTIAL (MF-M)

PERMITTED USE: #41 RAIL TRANSPORTATION: TERMINAL
 MAXIMUM BUILDING HEIGHT: 30' PER ZONING CODE

OCCUPANCY CLASSIFICATION: A-3: WAITING AREAS IN TRANSPORTATION TERMINALS & U: UTILITY

CONSTRUCTION TYPE: 11B

EMERGENCY EXITING CAPACITY CALCULATIONS

AREA DESCRIPTION (OCCUPANCY TYPE)	FLOOR AREA (SF)	OCCUPANCY FACTOR (SF/OCC)	OCCUPANT LOAD (OCC)	REQ EXIT WIDTH (0.2"/OCC) (36" MIN)	PROVIDED EXIT WIDTH (IN)	REQ STAIR WIDTH (0.3"/OCC) (44" MIN)	PROVIDED STAIR WIDTH (IN)
PLATFORM WESTBOUND (TOTAL)			311	63	180	N/A	N/A
PLATFORM WAITING AREA (A-3)	4,560	15	304				
CONCOURSE AREAS (A-3)*	480	100	5				
ANCILLARY ACCESSORY (A-3)	400	300	2				
PLATFORM EASTBOUND (TOTAL)			312	63	180	N/A	N/A
PLATFORM WAITING AREA (A-3)	4,560	15	304				
CONCOURSE AREAS (A-3)*	480	100	5				
ANCILLARY ACCESSORY (A-3)	280	300	1				
UTILITY (U)	480	300	2				

*CONCOURSE AREAS INCLUDE: TICKET VENDING AND WALKWAYS

EMERGENCY EXITING TIMED ANALYSIS CALCULATIONS

ELEMENT DESCRIPTION:	4 MIN TIMED ANALYSIS:							6 MIN TIMED ANALYSIS:					
	PEAK 15 MIN LINE LOADS (OCC)	PEAK BOARDING LOADS (OCC)	ALIGHTING LOADS (OCC)	ADJUSTED PLATFORM OCCUPANCY LOAD (OCC)	WIDTH OF ELEMENT (IN)	PIM (OCC/IN/MIN)	EXIT CAPACITY (OCC/MIN)	PLATFORM EXIT TIME (MIN)	LENGTH (FT)	EXIT ROUTE FT/MIN	EXIT TIME (MIN)	EXIT WAITING TIME (MIN)	TOTAL EXIT TIME (MIN)
WESTBOUND PLATFORM	725	23	0	698				1.551			2.839	0.019	2.858
PLATFORM									190	124	1.532		
RAMP					216	2.08	450		40	124	0.323		
CROSSING									38	124	0.306		
PLAZA									84	124	0.677		
EASTBOUND PLATFORM	725	0	23	677				1.504			2.532	0.000	2.532
PLATFORM									190	124	1.532		
RAMP					216	2.08	450		40	124	0.323		
PLAZA									84	124	0.677		

MUNICIPAL CODE LEGEND

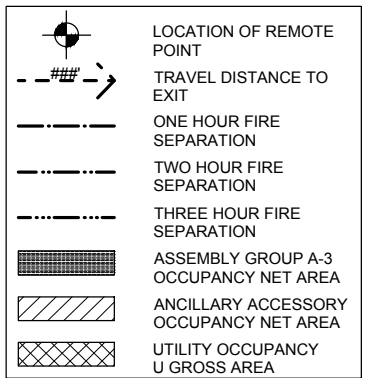

ORIGINATED BY: / DATE: /
 CHECKED BY: / DATE: /
 CORRECTED BY: / DATE: /
 VERIFIED BY: / DATE: /

11/19/13 | 3:09 PM | CALDWELL
 C:\USERS\PUBLIC\DOCUMENTS\CALDWELL\PROJECTS\SHARPOINT\SOUNDTRANSIT\ORG\443\SITES\CALDWELL\RED\E335\DRAWINGS\E335-E11-AAP001.DWG

60% SUBMITTAL

DESIGNED BY:
M. REDDINGTON
 DRAWN BY:
T. SCHAFER
 CHECKED BY:
H. FITZPATRICK
 APPROVED BY:
J. SCHUTT

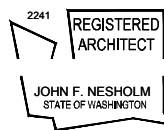

SCALE:
1" = 20'
 FILENAME:
E335-E11-AAP001
 CONTRACT No.:
RTA/LR XXXX-XX
 DATE:
12/20/2013

**EAST LINK EXTENSION
 CONTRACT E335**
 DOWNTOWN BELLEVUE TO SPRING DISTRICT
 EAST MAIN STATION - ARCHITECTURAL
 MUNICIPAL CODE INFORMATION

DRAWING No.:
E11-AAP001
 LOCATION ID:
E11
 SHEET No.:
REV:
0

No.	DATE	DSN	CHK	APP	REVISION

XREF LIST:
 XE335-GB-TB22x34
 XE335-L86-CAP100
 XE335-L86-CMP100
 XE335-E11-LPP100
 XEL-0525x
 XE335-E11-APP100
 XE335-L86-CRP100
 XE335-L86-CPP100
 XE335-E11-LSP100
 XEL-0525x
 XE335-E11-APP100
 XE335-L86-SWP100
 XE335-L86-COP100
 XE335-L86-JEP100
 GB-SEAL-JFN2241

ORIGINATED BY: / DATE: /
 CHECKED BY: / DATE: /
 BACK-CHECKED BY: / DATE: /
 11/19/13 12:42 PM | CALDWELL
 C:\USERS\PUBLIC\DOCUMENTS\CALDWELL\HITTPS\SHAREPOINT\SOUNDTRANSIT\ORG\443\SITES\CAD\BELRED\E335\E11-APP101.DWG

- NOTES:
- 1) SEE DRAWINGS E11-AFP101 THRU E11-AFP103 FOR FLOOR FINISHES
 - 2) SEE LANDSCAPE DRAWINGS FOR PLAZA HARDSCAPE FINISHES & PLANTINGS
 - 3) SEE CIVIL DRAWINGS FOR PLAZA & SITE FINISH GRADES
 - 4) SEE DRAWINGS E11-ANP100 THRU E11-INP103 FOR SIGNAGE

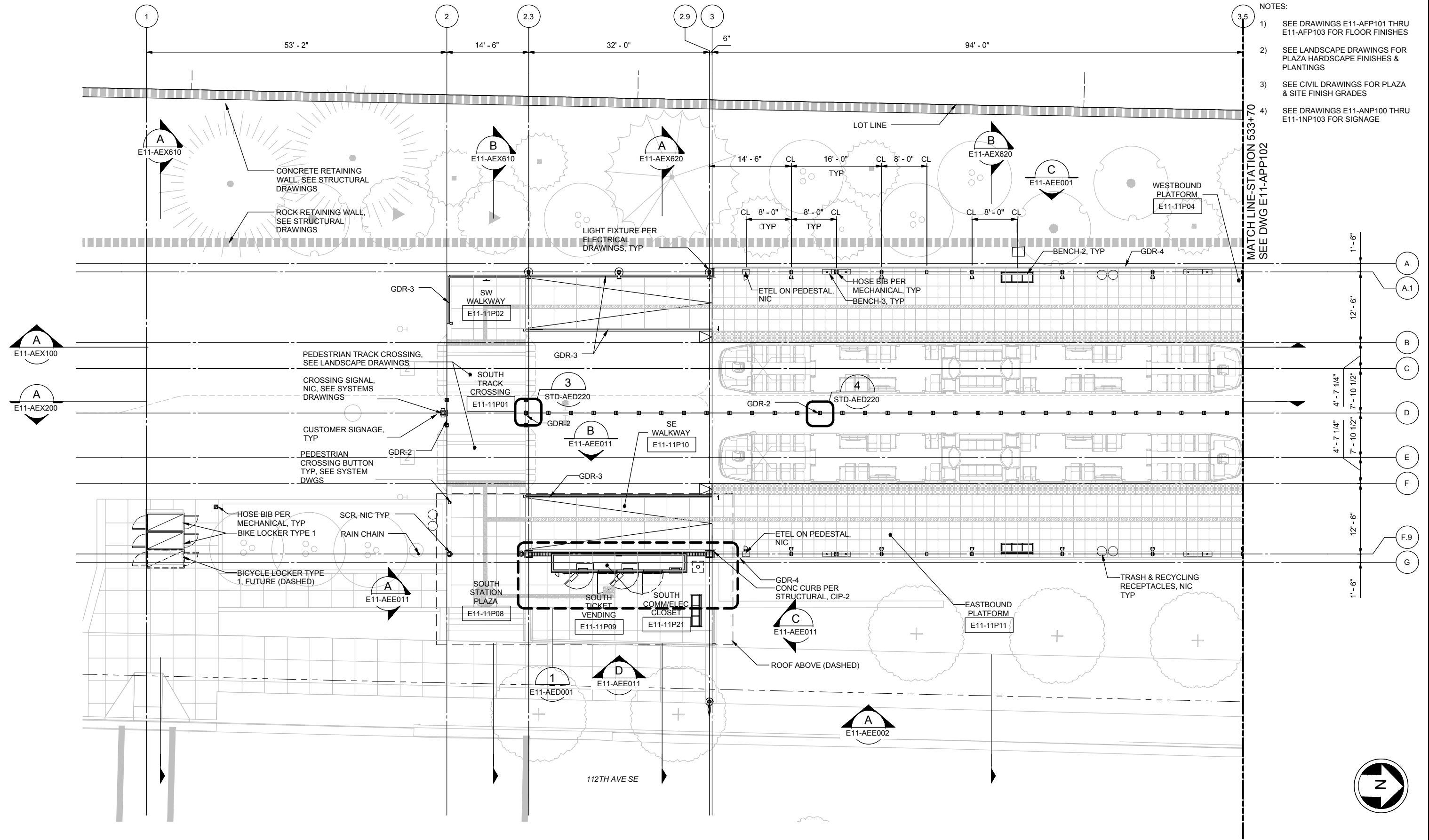

60% SUBMITTAL

DESIGNED BY:
M. REDDINGTON
 DRAWN BY:
T. SCHAFER
 CHECKED BY:
H. FITZPATRICK
 APPROVED BY:
J. SCHUTT

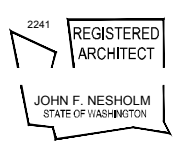

LINE IS 1" AT FULL SCALE



SCALE:
1/8" = 1'-0"
 FILENAME:
E335-E11-APP101
 CONTRACT No.:
RTA/LR XXXX-XX
 DATE:
12/20/2013

**EAST LINK EXTENSION
 CONTRACT E335**
 DOWNTOWN BELLEVUE TO SPRING DISTRICT
 EAST MAIN STATION - ARCHITECTURAL
 FLOOR PLAN
 SOUTH

DRAWING No.:
E11-APP101
 LOCATION ID:
E11
 SHEET No.:
REV:
0

XREF LIST:
 XE335-GB-TB22x34
 XE335-L86-CAP100
 XE335-E11-LPP100
 XE-L-0525x
 XE335-E11-APP100
 XE-L-0525f
 XE335-E11-APP100
 XE335-L86-SWP100
 XE335-L86-JOP100
 XE335-L86-HEP100
 GB-SEAL-JFN2241

ORIGINATED BY: / DATE: /
 CHECKED BY: / DATE: /
 CORRECTED BY: / DATE: /
 VERIFIED BY: / DATE: /
 11/19/13 12:42 PM | CALDWELL
 C:\USERS\PUBLIC\DOCUMENTS\CALDWELL\HITTPS\SHAREPOINT\ SOUNDTRANSIT\ORG\443\SITES\CAD\BELRED\E335DRAWINGS\E335-E11-APP102.DWG

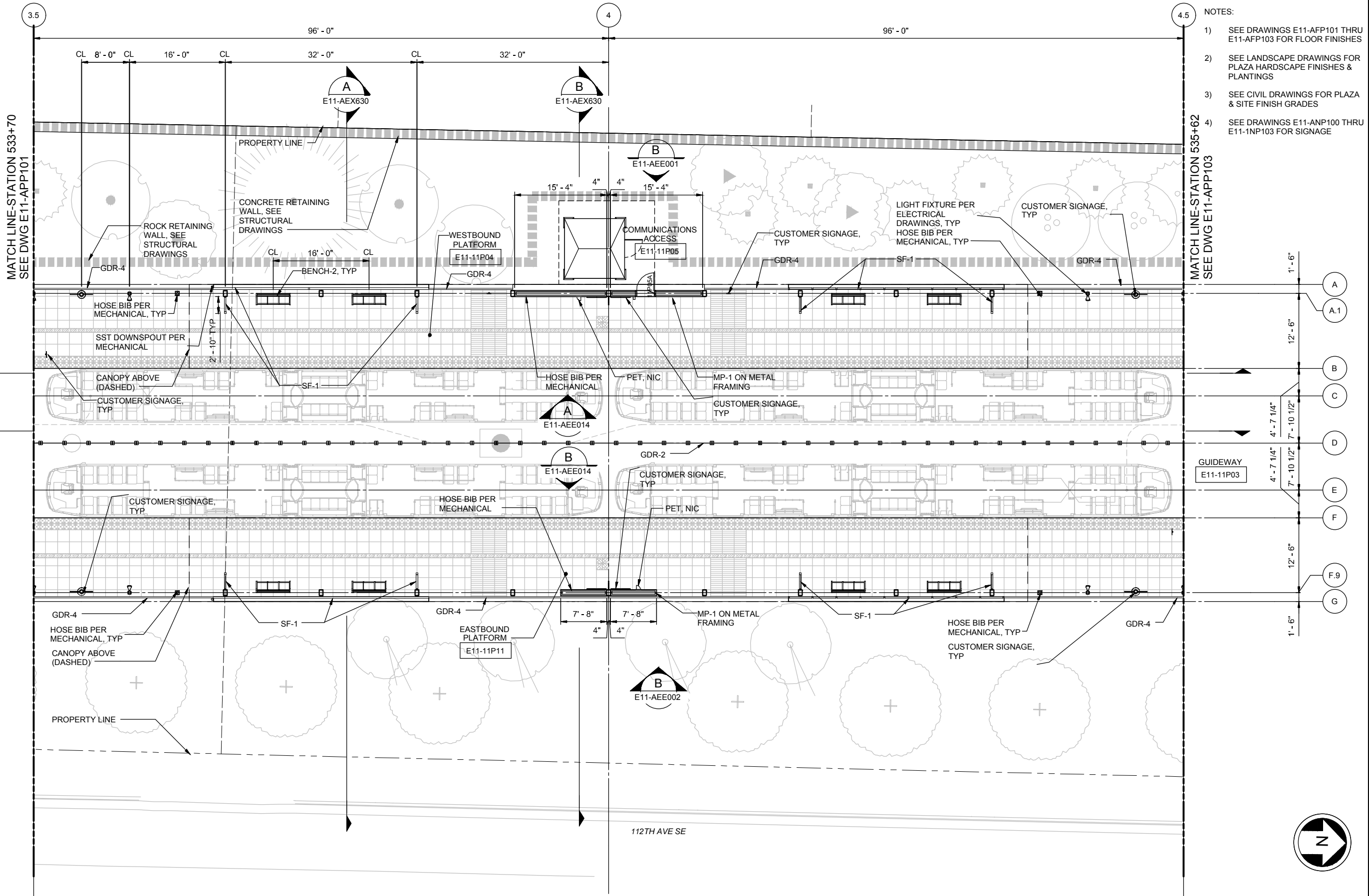

- NOTES:
- 1) SEE DRAWINGS E11-AFP101 THRU E11-AFP103 FOR FLOOR FINISHES
 - 2) SEE LANDSCAPE DRAWINGS FOR PLAZA HARDSCAPE FINISHES & PLANTINGS
 - 3) SEE CIVIL DRAWINGS FOR PLAZA & SITE FINISH GRADES
 - 4) SEE DRAWINGS E11-ANP100 THRU E11-1NP103 FOR SIGNAGE

60% SUBMITTAL

DESIGNED BY:
M. REDDINGTON
 DRAWN BY:
T. SCHAFFER
 CHECKED BY:
H. FITZPATRICK
 APPROVED BY:
J. SCHUTT

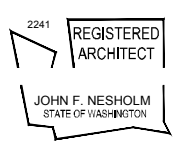

LINE IS 1" AT FULL SCALE



SCALE:
1/8" = 1'-0"
 FILENAME:
E335-E11-APP102
 CONTRACT No.:
RTA/LR XXXX-XX
 DATE:
12/20/2013

EAST LINK EXTENSION
 CONTRACT E335
 DOWNTOWN BELLEVUE TO SPRING DISTRICT
 EAST MAIN STATION - ARCHITECTURAL
 CENTRAL

DRAWING No.:
E11-APP102
 LOCATION ID:
E11
 SHEET No.: REV:
0

NOTES:

- 1) SEE DRAWINGS E11-APP101 THRU E11-APP103 FOR FLOOR FINISHES
- 2) SEE LANDSCAPE DRAWINGS FOR PLAZA HARDSCAPE FINISHES & PLANTINGS
- 3) SEE CIVIL DRAWINGS FOR PLAZA & SITE FINISH GRADES
- 4) SEE DRAWINGS E11-APP100 THRU E11-APP103 FOR SIGNAGE

XREF LIST:
 XE335-08-TB2x34
 XE335-08-CAP100
 XE335-E11-LPP100
 XE1-0528x
 XE1-0525x
 XE335-E11-APP100
 XE335-08-KAP100
 XE335-E11-LSP100
 XE335-08-CRP100
 XE1-0525x
 XE335-E11-APP100
 XE335-08-SWP100
 XE335-08-JOP100
 XE335-08-JEP100
 GB-SEAL-JFN2241

ORIGINATED BY: / DATE: /
 CHECKED BY: / DATE: /
 CORRECTED BY: / DATE: /
 VERIFIED BY: / DATE: /
 11/19/13 | 12:43 PM | CALDWELL
 C:\USERS\PUBLIC\DOCUMENTS\CALDWELL\H\TTPS\SHAREPOINT\SOUNDTRANSIT\ORG\443\SITES\CAD\BELRED\E335\DRAWINGS\E335-E11-APP103.DWG

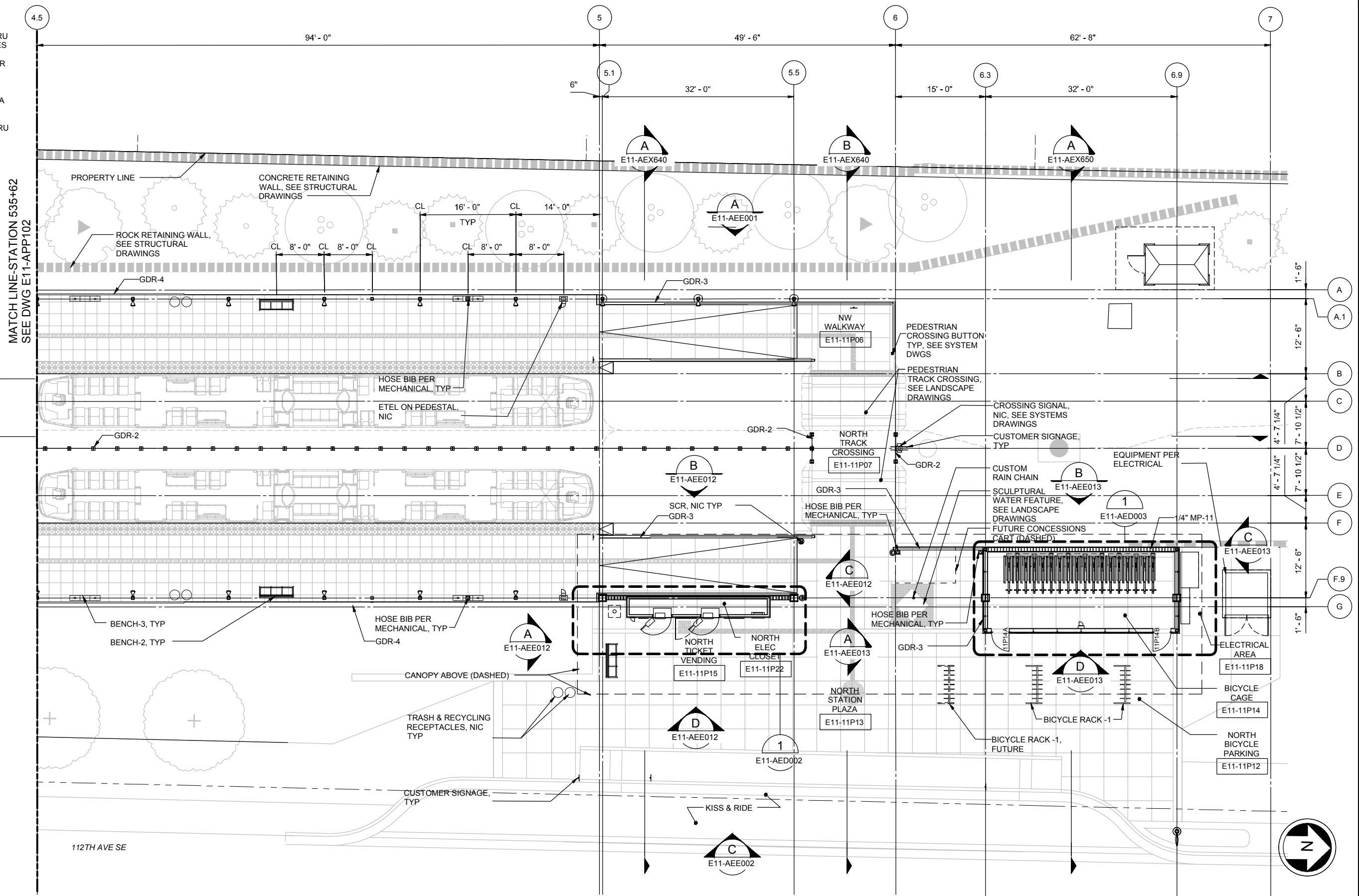

60% SUBMITTAL

DESIGNED BY:
M. REDDINGTON
 DRAWN BY:
T. SCHAEFFER
 CHECKED BY:
H. FITZPATRICK
 APPROVED BY:
J. SCHUTT

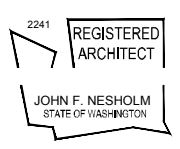

LINE IS 1" AT FULL SCALE



SCALE:
1/8" = 1'-0"
 FILENAME:
E335-E11-APP103
 CONTRACT No.:
RTA/LR XXXX-XX
 DATE:
12/20/2013

EAST LINK EXTENSION
CONTRACT E335
 DOWNTOWN BELLEVUE TO SPRING DISTRICT
 EAST MAIN STATION - ARCHITECTURAL
 FLOOR PLAN
 NORTH

DRAWING No.:	E11-APP103
LOCATION ID:	E11
SHEET No.:	REV:
	0

XREF LIST:
 E335-GB-TB2234
 E335-E11-AEX200
 GB-SEAL-JFN2241

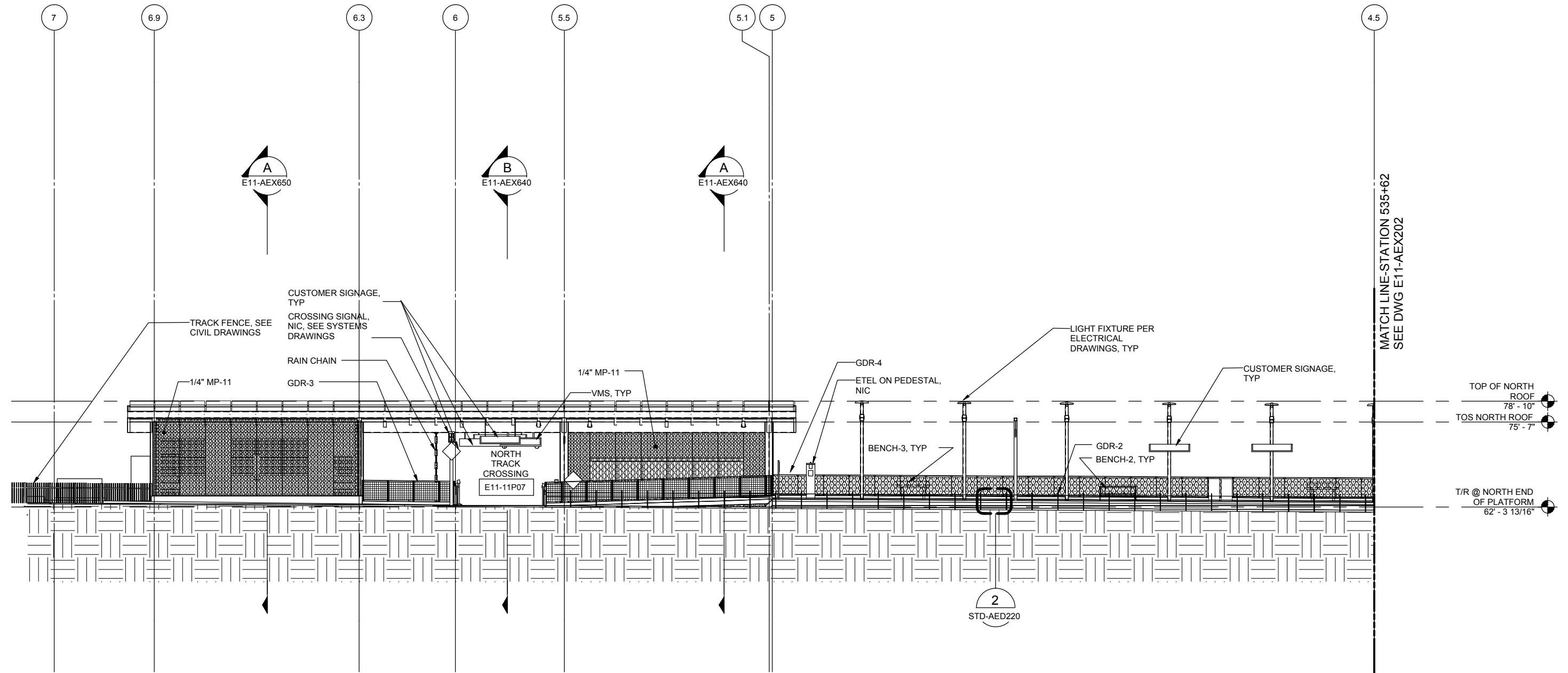

LONGITUDINAL SECTION 2 - NORTH - LOOKING EAST

SCALE: 1/8" = 1'-0"



ORIGINATED BY: / DATE: /
 CHECKED BY: / DATE: /
 BACK-CHECKED BY: / DATE: /
 11/19/13 | 12:38 PM | CALDWELL
 C:\USERS\PUBLIC\DOCUMENTS\CALDWELL\H\TTPS\SHAREPOINT\SOUNDTRANSIT\ORG\443\SITES\CAD\EL\BEL\RED\E335-E11-AEX201.DWG

60% SUBMITTAL					
No.	DATE	DSN	CHK	APP	REVISION

DESIGNED BY:
M. REDDINGTON

DRAWN BY:
T. SCHAFFER

CHECKED BY:
H. FITZPATRICK

APPROVED BY:
J. SCHUTT

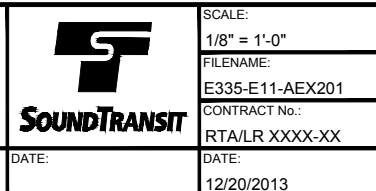
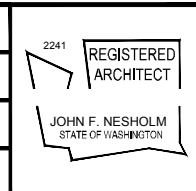

EAST LINK EXTENSION CONTRACT E335

DOWNTOWN BELLEVUE TO SPRING DISTRICT

EAST MAIN STATION - ARCHITECTURAL LONGITUDINAL SECTION 2 SOUTH - LOOKING EAST

DRAWING No.:	E11-AEX201
LOCATION ID:	E11
SHEET No.:	0

XREF LIST:
 E335-GB-TB2234
 E335-E11-AEX200
 GB-SEAL-JFN2241

ORIGINATED BY: / DATE: /
 CHECKED BY: / DATE: /
 CORRECTED BY: / DATE: /
 BACK-CHECKED BY: / DATE: /
 VERIFIED BY: / DATE: /
 11/19/13 12:38 PM | CALDWELL
 C:\USERS\PUBLIC\DOCUMENTS\CALDWELL\H\TTPS\SHAREPOINT\SOUNDTRANSIT\ORG\443\SITES\CAD\ELBEL\RED\E335-E11-AEX200.DWG

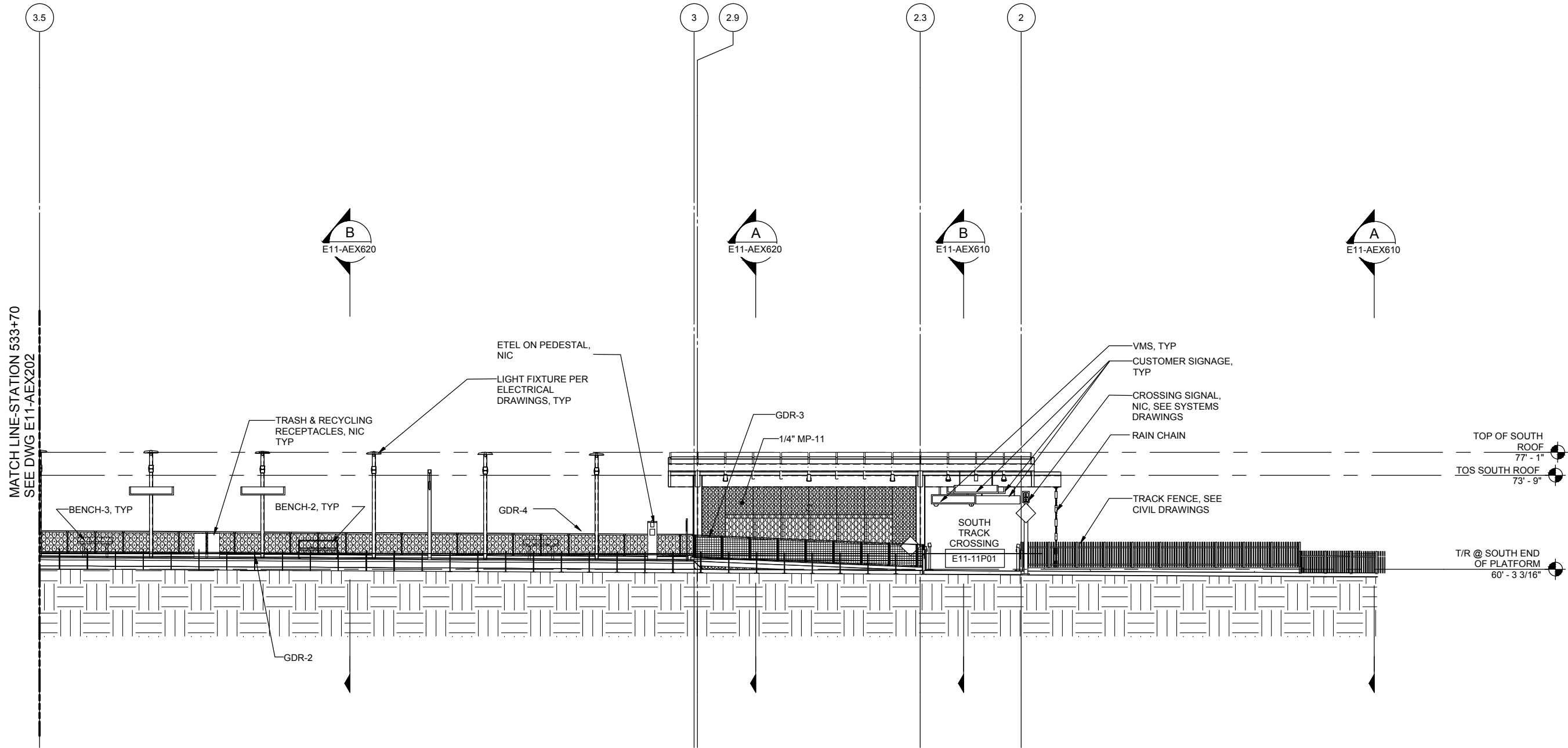

LONGITUDINAL SECTION 2 - SOUTH - LOOKING EAST

SCALE: 1/8" = 1'-0"



60% SUBMITTAL

DESIGNED BY:
M. REDDINGTON
 DRAWN BY:
T. SCHAFER
 CHECKED BY:
H. FITZPATRICK
 APPROVED BY:
J. SCHUTT

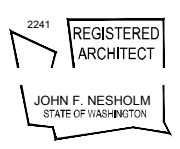

LINE IS 1" AT FULL SCALE



SCALE:
1/8" = 1'-0"
 FILENAME:
E335-E11-AEX203
 CONTRACT No.:
RTA/LR XXXX-XX
 DATE:
12/20/2013

EAST LINK EXTENSION
 CONTRACT E335
 DOWNTOWN BELLEVUE TO SPRING DISTRICT
 EAST MAIN STATION - ARCHITECTURAL
 LONGITUDINAL SECTION 2
 NORTH - LOOKING EAST

DRAWING No.:
E11-AEX203
 LOCATION ID:
E11
 SHEET No.:
REV:
0

XREF LIST:
 XE335-L86-KAP100
 XEL-0525fx
 XEL-0525ff
 GB-SEAL-MY371
 XEL-0525g
 XEL-0525h
 XE335-E11-LSP100
 XE335-E11-LPP100
 XE335-L86-SWP100
 XE335-G8-TR23-24
 XE335-L86-CRP100
 XE335-L86-TSP100
 XE335-L86-UCP100
 XE335-L86-CMP100
 XE335-L86-GZV020
 XE335-E11-APP100
 XE335-E11-APP100
 XE335-L86-CLP100
 XE335-L86-RPP100
 XE330-L85-KAP100
 XE335-L86-CGP100
 XE330-L85-CRP100

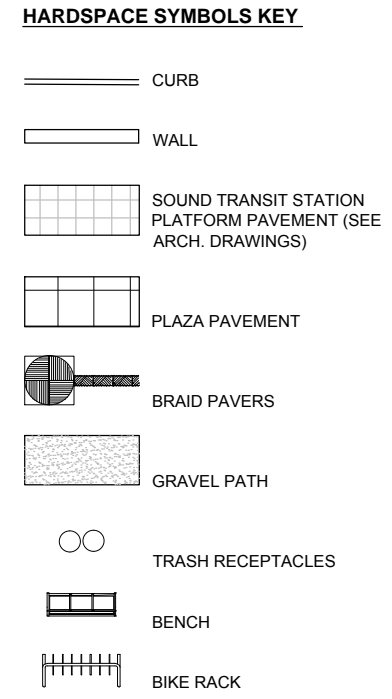
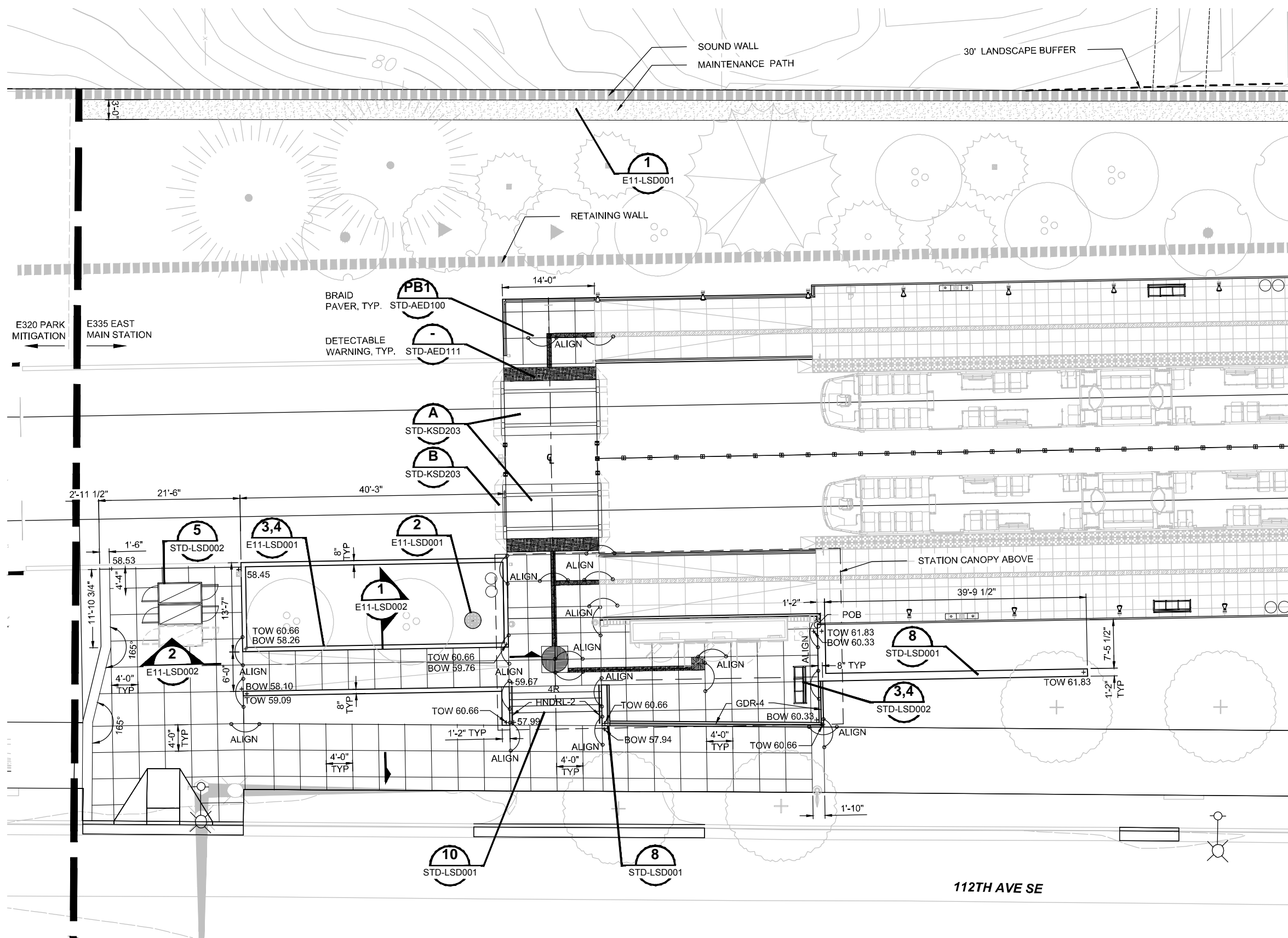

SEE DWG E11-LSP101

- NOTES**
1. ALL MEASUREMENTS TAKEN FROM CURBLINES ARE DIMENSIONED FROM THE BACK OF CURB.
 2. POB = POINT OF BEGINNING FOR CONCRETE JOINT LAYOUT.
 3. SEE DWG E11-XXXXXX FOR STATION ARCHITECTURAL PLAN.
 4. SEE ARCH DRAWINGS FOR ADDITIONAL SITE FURNISHING.
 5. SEE CIVIL FOR ROADWAY CURB DIMENSIONS.

ORIGINATED BY: / DATE: /
 CHECKED BY: / DATE: /
 BACK-CHECKED BY: / DATE: /
 11/28/13 | 7:15 AM | CALDWELL
 C:\USERS\PUBLIC\DOCUMENTS\CALDWELL\H\TTPS\SHAREPOINT\SOUNDTRANSIT\ORG\443\SITES\CAD\BEL\RED\E335DRAWINGS\E335-E11-LSP100.DWG



60% SUBMITTAL

DESIGNED BY:
A. WEST
 DRAWN BY:
N. MARSHALL
 CHECKED BY:
M. YAMAGUCHI
 APPROVED BY:
J. SCHUTT



NAKANO ASSOCIATES
 LANDSCAPE ARCHITECTS
 853 Hiawatha Place S.
 Seattle, WA 98144
 Tel: 206.292.9392
 www.nakanolandscape.com



LINE IS 1" AT FULL SCALE



SCALE:
 1/8"=1'-0"
 FILENAME:
E335-E11-LSP100
 CONTRACT No.:
RTA/LR XXXX-XX
 DATE:
 12/20/2013

EAST LINK EXTENSION
CONTRACT E335
 DOWNTOWN BELLEVUE TO SPRING DISTRICT
 LANDSCAPE
 HARDSPACE PLAN - WEST
 EAST MAIN STATION

DRAWING No.:
E11-LSP100
 LOCATION ID:
E11
 SHEET No.:
 REV:
0

No.	DATE	DSN	CHK	APP	REVISION

XREF LIST:
 XE335-L86-KAP100
 XEL-0525fx
 XEL-0525ff
 XEL-0528x
 XEL-0528ff
 XE335-E11-LSP100
 GB-SEAL-MY371
 XEL-0525vg
 XEL-0529vg
 XEL-0525cn
 XEL-0528cn
 XE335-GB-TB22x34
 XE335-L86-CLP100
 XE335-L86-CDP100
 XE335-L86-CMP100
 XE335-L86-TSP100
 XE335-L86-SWP100
 XE320-L85-SWP100
 XE335-L86-CRP100
 XE335-E11-LSP100
 XE335-E11-APP100
 XE335-L86-RPP100

ORIGINATED BY: / DATE: /
 CHECKED BY: / DATE: /
 BACK-CHECKED BY: / DATE: /
 11/28/13 | 7:16 AM | CALDWELL
 C:\USERS\PUBLIC\DOCUMENTS\CALDWELL\HITTPS\SHAREPOINT\SOUNDTRANSIT\ORG\443\SITES\CAD\EL\RED\E335-E11-LSP101.DWG

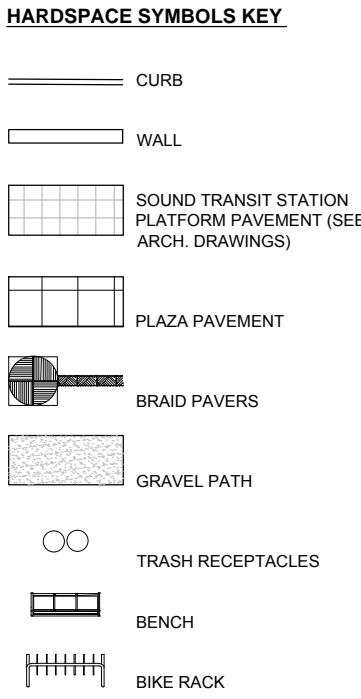
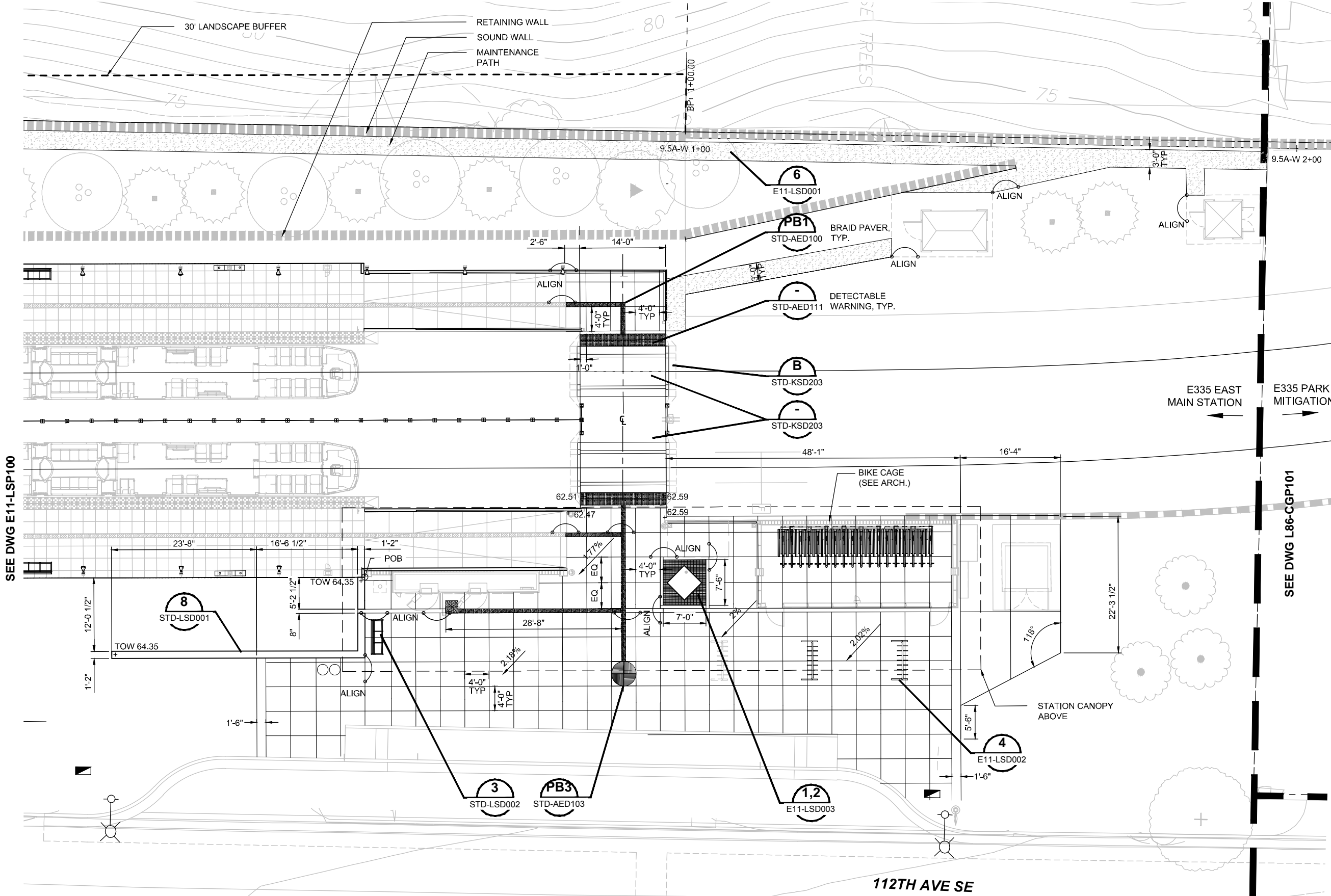

- NOTES**
1. ALL MEASUREMENTS TAKEN FROM CURBLINES ARE DIMENSIONED FROM THE BACK OF CURB.
 2. POB = POINT OF BEGINNING FOR CONCRETE JOINT LAYOUT.
 3. SEE DWG E11-XXXXXX FOR STATION ARCHITECTURAL PLAN.
 4. SEE ARCH DRAWINGS FOR ADDITIONAL SITE FURNISHING.
 5. SEE CIVIL FOR ROADWAY CURB DIMENSIONS.



60% SUBMITTAL

DESIGNED BY:
A. WEST
 DRAWN BY:
N. MARSHALL
 CHECKED BY:
M. YAMAGUCHI
 APPROVED BY:
J. SCHUTT



NAKANO ASSOCIATES
 LANDSCAPE ARCHITECTS
 853 Hiawatha Place S.
 Seattle, WA 98144
 Tel: 206.292.9392
 www.nakanolandscape.com



LINE IS 1" AT FULL SCALE



SCALE:
1/8"=1'-0"
 FILENAME:
E335-E11-LSP101
 CONTRACT No.:
RTA/LR XXXX-XX
 DATE:
12/20/2013

**EAST LINK EXTENSION
 CONTRACT E335**
 DOWNTOWN BELLEVUE TO SPRING DISTRICT
 LANDSCAPE
 HARDSCAPE PLAN - EAST
 EAST MAIN STATION

DRAWING No.:
E11-LSP101
 LOCATION ID:
E11
 SHEET No.:
REV:
0

XREF LIST:
 *E335-GB-TB22-34
 *E335-E15-APP103
 *E335-L86-CRP100
 *E335-E15-LSP100
 GB-SEAL-JFN2241

ORIGINATED BY: / DATE: /
 CHECKED BY: / DATE: /
 CORRECTED BY: / DATE: /
 VERIFIED BY: / DATE: /
 12/09/13 9:35 AM CALDWELL
 C:\USERS\PUBLIC\DOCUMENTS\CALDWELL\HTTTPS\SHAREPOINT\SOUNDTRANSIT\ORG\443\SITES\CAD\ELBEL\RED\E335\E15-APP103.DWG

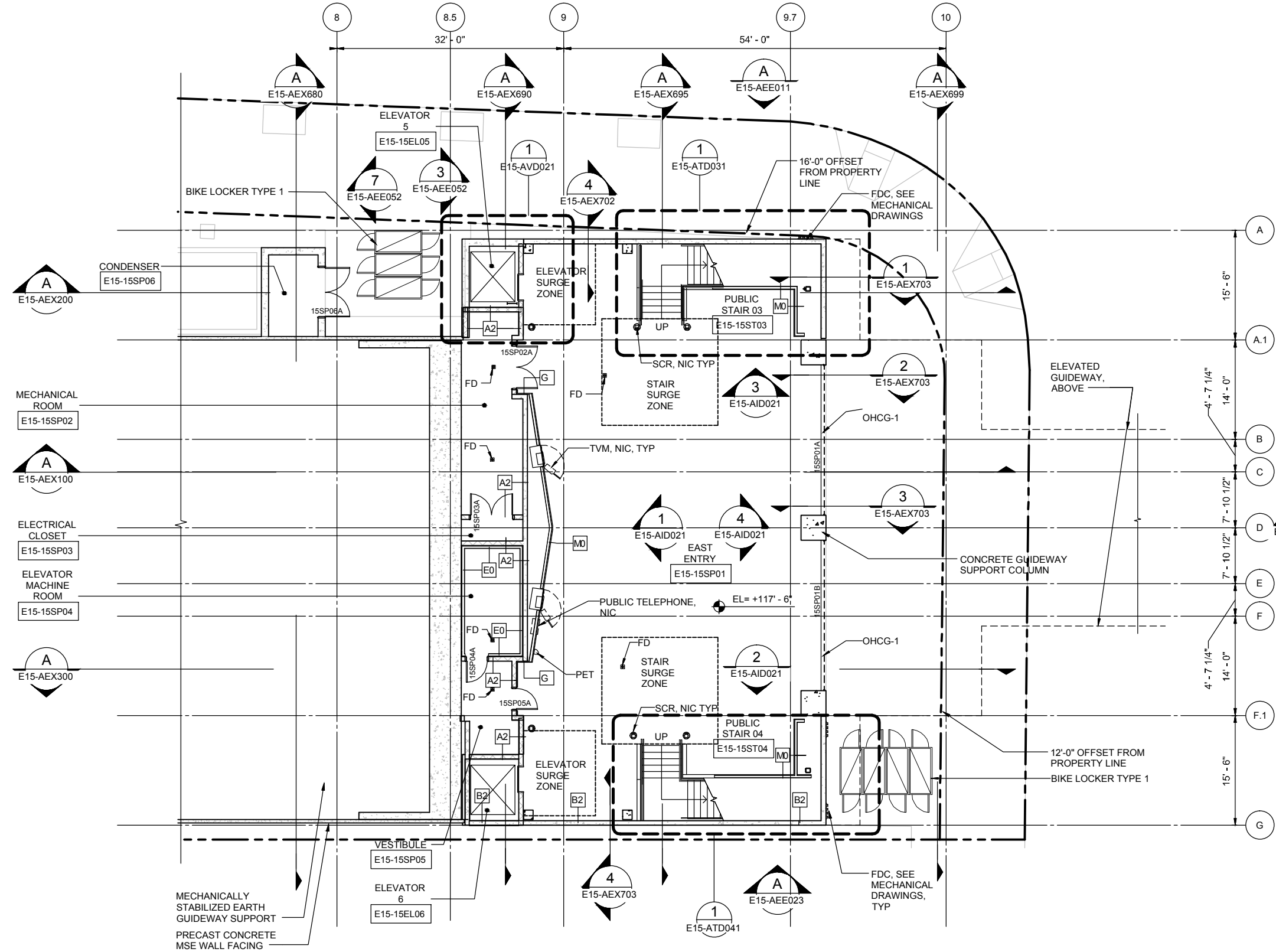

60% SUBMITTAL

DESIGNED BY:
M. REDDINGTON
 DRAWN BY:
E. NOTHDURFT
 CHECKED BY:
H. FITZPATRICK
 APPROVED BY:
J. SCHUTT

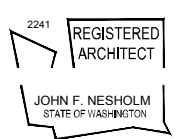

LINE IS 1" AT FULL SCALE



SCALE:
 1/8" = 1'-0"
 FILENAME:
 E335-E15-APP103
 CONTRACT No.:
 RTA/LR XXXX-XX
 DATE:
 12/20/2013

**EAST LINK EXTENSION
 CONTRACT E335**
 DOWNTOWN BELLEVUE TO SPRING DISTRICT
**BTC STATION
 FLOOR PLAN
 LOWER STREET LEVEL - EAST SECTOR**

DRAWING No.:
E15-APP103
 LOCATION ID:
E15
 SHEET No.:
 REV:
0

XREF LIST:
 XE335-GB-TB2204
 XE335-E15-APP201
 XE335-L96-STP003
 GB-SEAL-JFN2241

ORIGINATED BY: / DATE: /
 CHECKED BY: / DATE: /
 BACK-CHECKED BY: / DATE: /
 12/09/13 9:35 AM CALDWELL
 C:\USERS\PUBLIC\DOCUMENTS\CALDWELL\PROJECTS\BAYVIEW\DRAWINGS\E335-E15-APP201.DWG

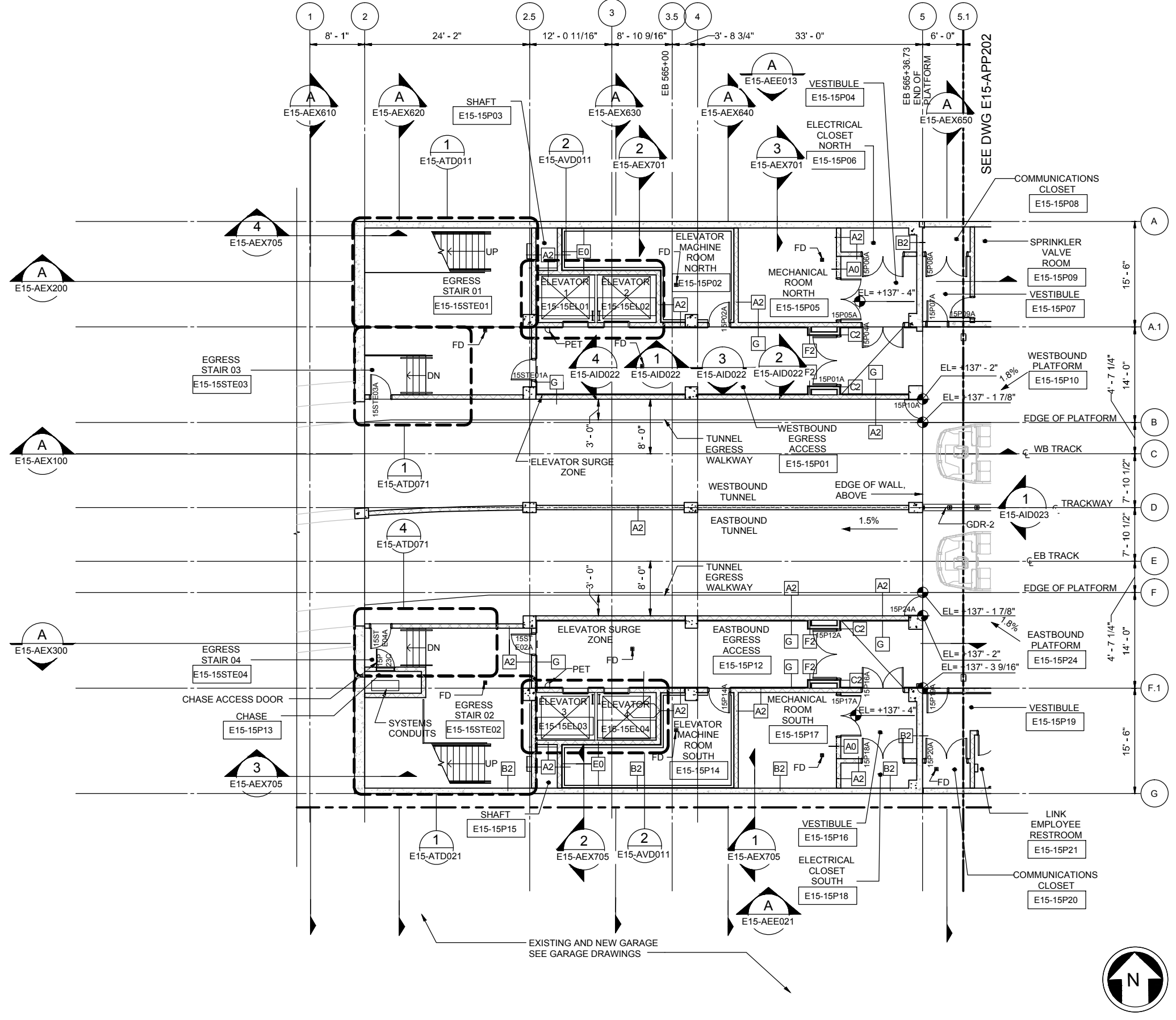

60% SUBMITTAL

DESIGNED BY:
M. REDDINGTON
 DRAWN BY:
E. NOTHDURFT
 CHECKED BY:
H. FITZPATRICK
 APPROVED BY:
J. SCHUTT



SCALE:
 1/8" = 1'-0"
 FILENAME:
 E335-E15-APP201
 CONTRACT No.:
 RTA/LR XXXX-XX
 DATE:
 12/20/2013

**EAST LINK EXTENSION
 CONTRACT E335**
 DOWNTOWN BELLEVUE TO SPRING DISTRICT
 BTC STATION
 FLOOR PLAN
 PLATFORM LEVEL - WEST SECTOR

DRAWING No.:
E15-APP201
 LOCATION ID:
E15
 SHEET No.:
 REV:
0

XREF LIST:
 XE335-GB-TB2204
 XE335-E15-APP200
 XE335-L86-CRP100
 XE335-E15-LSP100
 GB-SEAL-JFN2241

ORIGINATED BY: / DATE: /
 CHECKED BY: / DATE: /
 BACK-CHECKED BY: / DATE: /
 VERIFIED BY: / DATE: /
 12/09/13 | 9:35 AM | CALDWELL
 C:\USERS\PUBLIC\DOCUMENTS\CALDWELL\H\TTPS\SHAREPOINT\SOUNDTRANSIT\ORG\443\SITES\CAD\LIB\RED\E335\DRAWINGS\E15-APP202.DWG

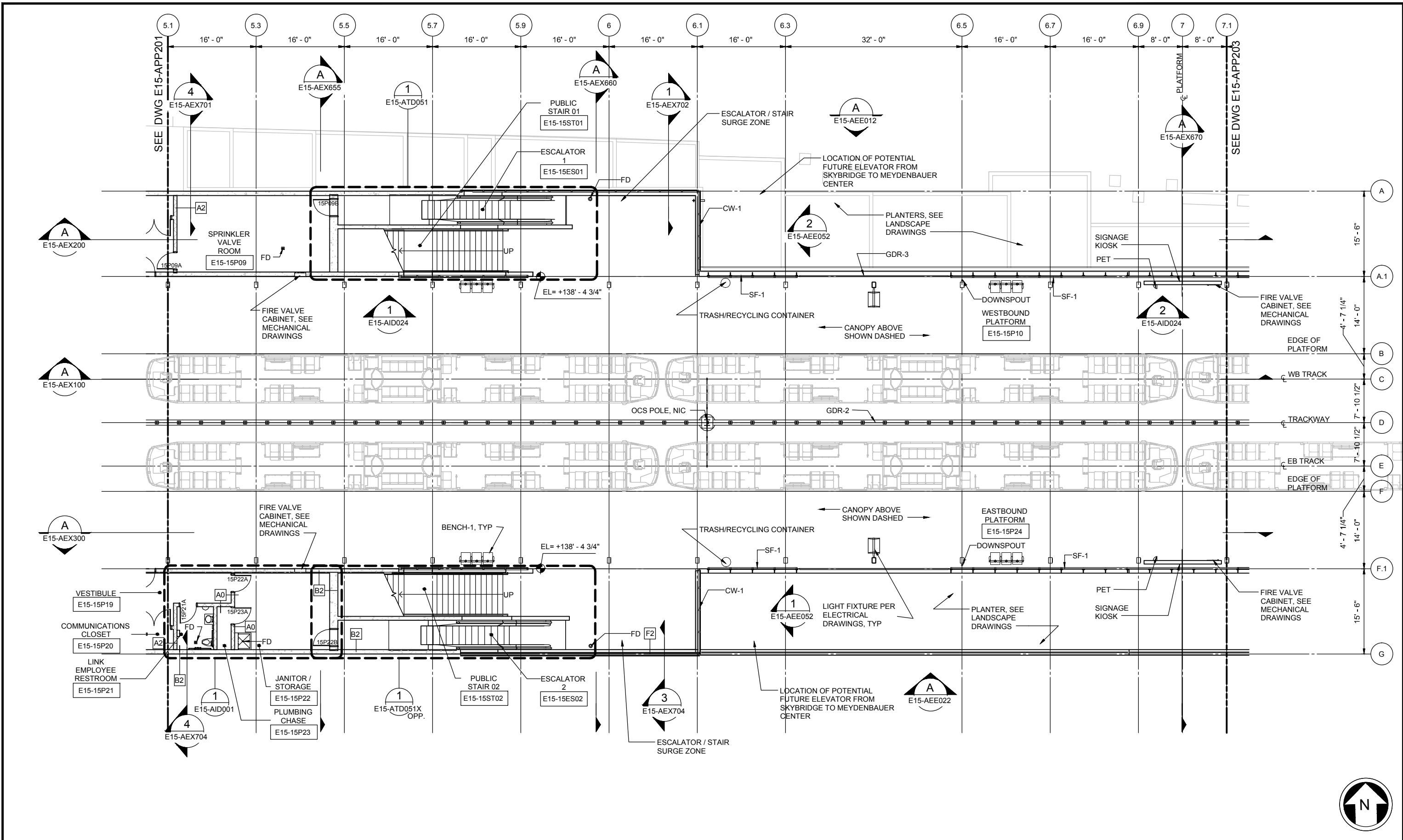

60% SUBMITTAL

DESIGNED BY:
M. REDDINGTON
 DRAWN BY:
E. NOTHDURFT
 CHECKED BY:
H. FITZPATRICK
 APPROVED BY:
J. SCHUTT

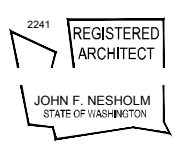

SCALE:
 1/8" = 1'-0"
 FILENAME:
 E335-E15-APP202
 CONTRACT No.:
 RTA/LR XXXX-XX
 DATE:
 12/20/2013

**EAST LINK EXTENSION
 CONTRACT E335**
 DOWNTOWN BELLEVUE TO SPRING DISTRICT
**BTC STATION
 FLOOR PLAN
 PLATFORM LEVEL - CENTRAL SECTOR**

DRAWING No.:
E15-APP202
 LOCATION ID:
E15
 SHEET No.:
0

XREF LIST:
 *E335-GB-TB2204
 *E335-E15-APP203
 *E335-L86-CRP100
 *E335-E15-LSP100
 GB-SEAL-JFN2241

ORIGINATED BY: / DATE: /
 CHECKED BY: / DATE: /
 BACK-CHECKED BY: / DATE: /
 C:\USERS\PUBLIC\DOCUMENTS\CALDWELL\HITTPS\SHAREPOINT\SOUNDTRANSIT\ORG\443\SITES\CAD\EL\RED\E335-E15-APP203.DWG

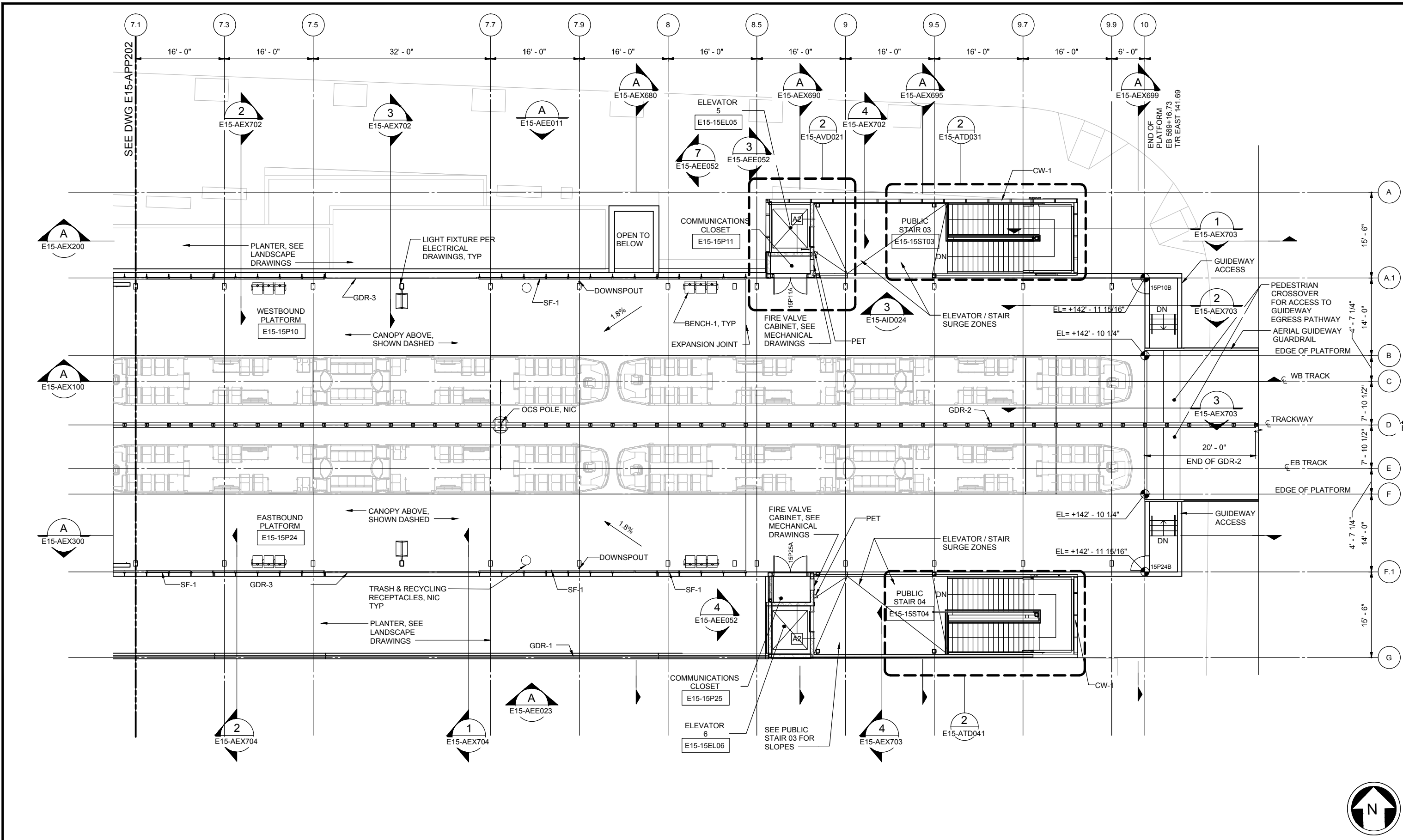

60% SUBMITTAL

DESIGNED BY:
M. REDDINGTON
 DRAWN BY:
E. NOTHDURFT
 CHECKED BY:
H. FITZPATRICK
 APPROVED BY:
J. SCHUTT

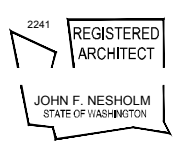

SCALE:
 1/8" = 1'-0"
 FILENAME:
 E335-E15-APP203
 CONTRACT No.:
 RTA/LR XXXX-XX
 DATE:
 12/20/2013

**EAST LINK EXTENSION
 CONTRACT E335**
 DOWNTOWN BELLEVUE TO SPRING DISTRICT
 BTC STATION
 FLOOR PLAN
 PLATFORM LEVEL - EAST SECTOR

DRAWING No.:
E15-APP203
 LOCATION ID:
E15
 SHEET No.:
0

No.	DATE	DSN	CHK	APP	REVISION

XREF LIST:
 XE335-GB-TB2234
 XE335-E15-APP401
 XE335-L86-CRP100
 XE335-E15-LSP100
 GB-SEAL-JFN2241

ORIGINATED BY: / DATE: /
 CORRECTED BY: / DATE: /
 CHECKED BY: / DATE: /
 VERIFIED BY: / DATE: /
 11/28/13 9:13 AM | CALDWELL
 C:\USERS\PUBLIC\DOCUMENTS\CALDWELL\HITTPS\SHAREPOINT\SOUNDTRANSIT\ORG\443\SITES\CAD\ELBEL\RED\E335-E15-APP401.DWG

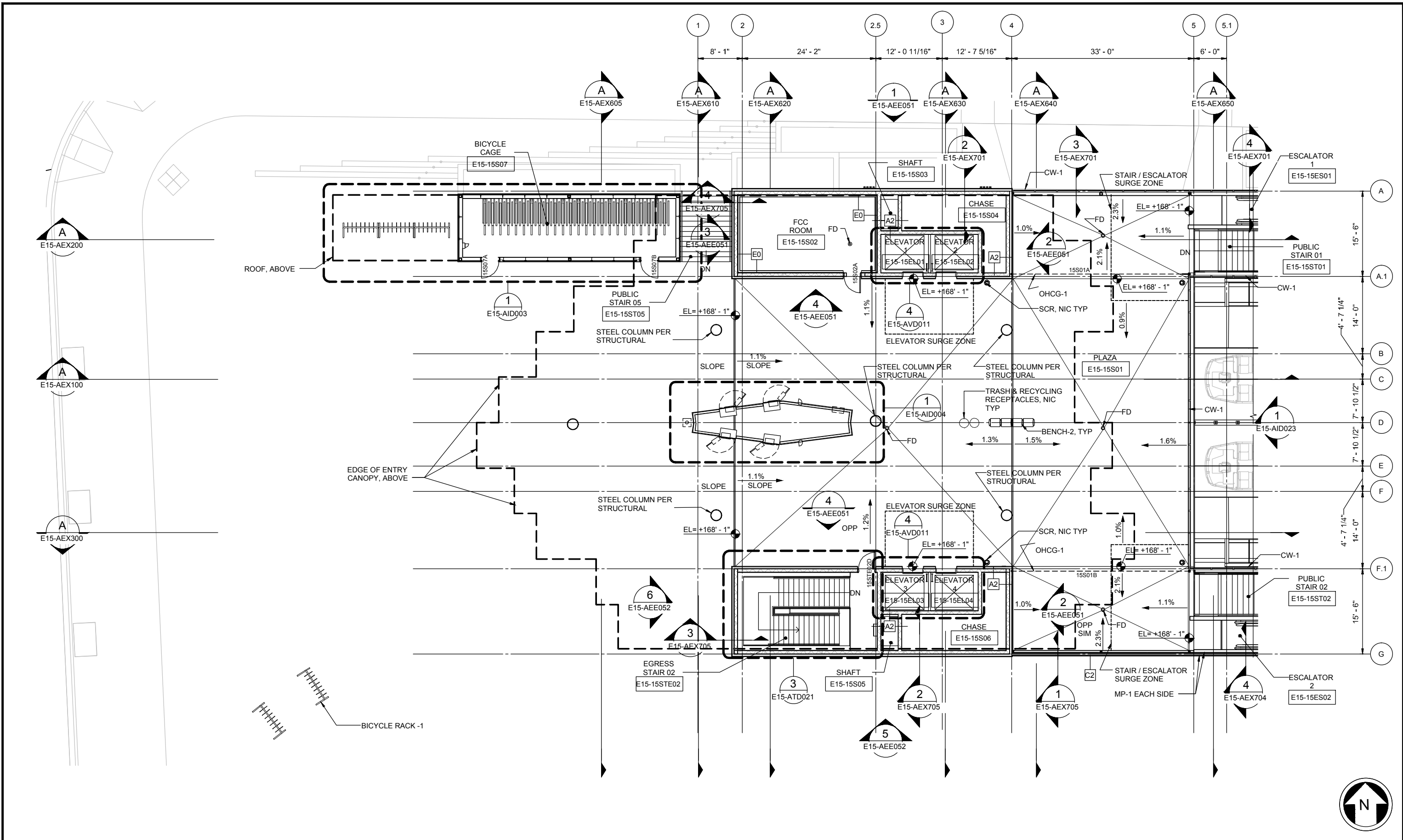

60% SUBMITTAL

DESIGNED BY:
M. REDDINGTON
 DRAWN BY:
E. NOTHDURFT
 CHECKED BY:
H. FITZPATRICK
 APPROVED BY:
J. SCHUTT

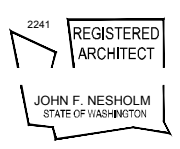

LINE IS 1" AT FULL SCALE



SCALE:
 1/8" = 1'-0"
 FILENAME:
 E335-E15-APP401
 CONTRACT No.:
 RTA/LR XXXX-XX
 DATE:
 12/20/2013

**EAST LINK EXTENSION
 CONTRACT E335**
 DOWNTOWN BELLEVUE TO SPRING DISTRICT
 BTC STATION
 FLOOR PLAN
 SURFACE LEVEL - WEST SECTOR

DRAWING No.:
E15-APP401
 LOCATION ID:
E15
 SHEET No.:
0
 REV:

XREF LIST:
 #E335-GB-TB22x34
 #E335-E15-AEE010
 GB-SEAL-JFN2241

ORIGINATED BY: / DATE: /
 CHECKED BY: / DATE: /
 BACK-CHECKED BY: / DATE: /
 11/28/13 9:10 AM | CALDWELL
 C:\USERS\PUBLIC\DOCUMENTS\CALDWELL\JHP\SHARPOINT\SOUNDTRANSIT\ORG\443\SITES\CAD\BELRED\E335-E15-AEE011.DWG

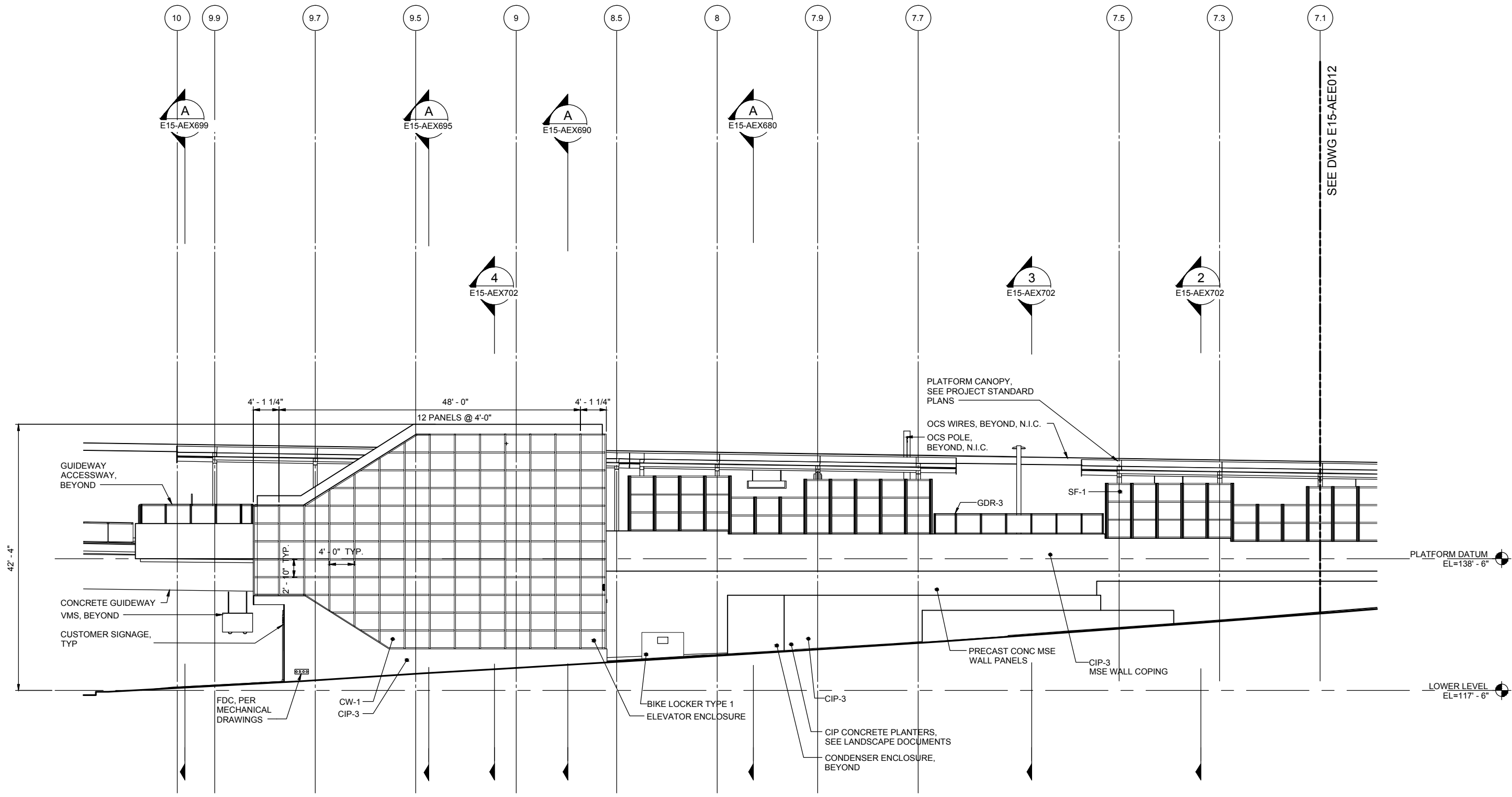

EXTERIOR ELEVATION - NORTH - EAST SECTOR
 SCALE: 1/8" = 1'-0"
 A
 E15-AEE011
 E15-AEE010

60% SUBMITTAL

DESIGNED BY:
 M. REDDINGTON
 DRAWN BY:
 E. NOTHDURFT
 CHECKED BY:
 H. FITZPATRICK
 APPROVED BY:
 J. SCHUTT

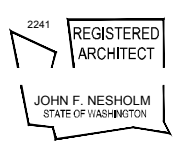

SCALE:
 1/8" = 1'-0"
 FILENAME:
 E335-E15-AEE011
 CONTRACT No.:
 RTA/LR XXXX-XX
 DATE:
 12/20/2013

**EAST LINK EXTENSION
 CONTRACT E335**
 DOWNTOWN BELLEVUE TO SPRING DISTRICT
 BTC STATION
 EXTERIOR ELEVATIONS
 NORTH - EAST

DRAWING No.:	E15-AEE011
LOCATION ID:	E15
SHEET No.:	0
REV:	0

XREF LIST:
 XE335-GB-TB22x34
 XE335-E15-AEE010
 GB-SEAL-JFN2241

ORIGINATED BY: / DATE: /
 CHECKED BY: / DATE: /
 CORRECTED BY: / DATE: /
 VERIFIED BY: / DATE: /
 11/22/13 11:30 AM | CALDWELL
 C:\USERS\PUBLIC\DOCUMENTS\CALDWELL\HITTPS\SHAREPOINT\SOUNDTRANSIT\ORG\443\SITES\CAD\ELBEL\RED\E335-E15-AEE012.DWG

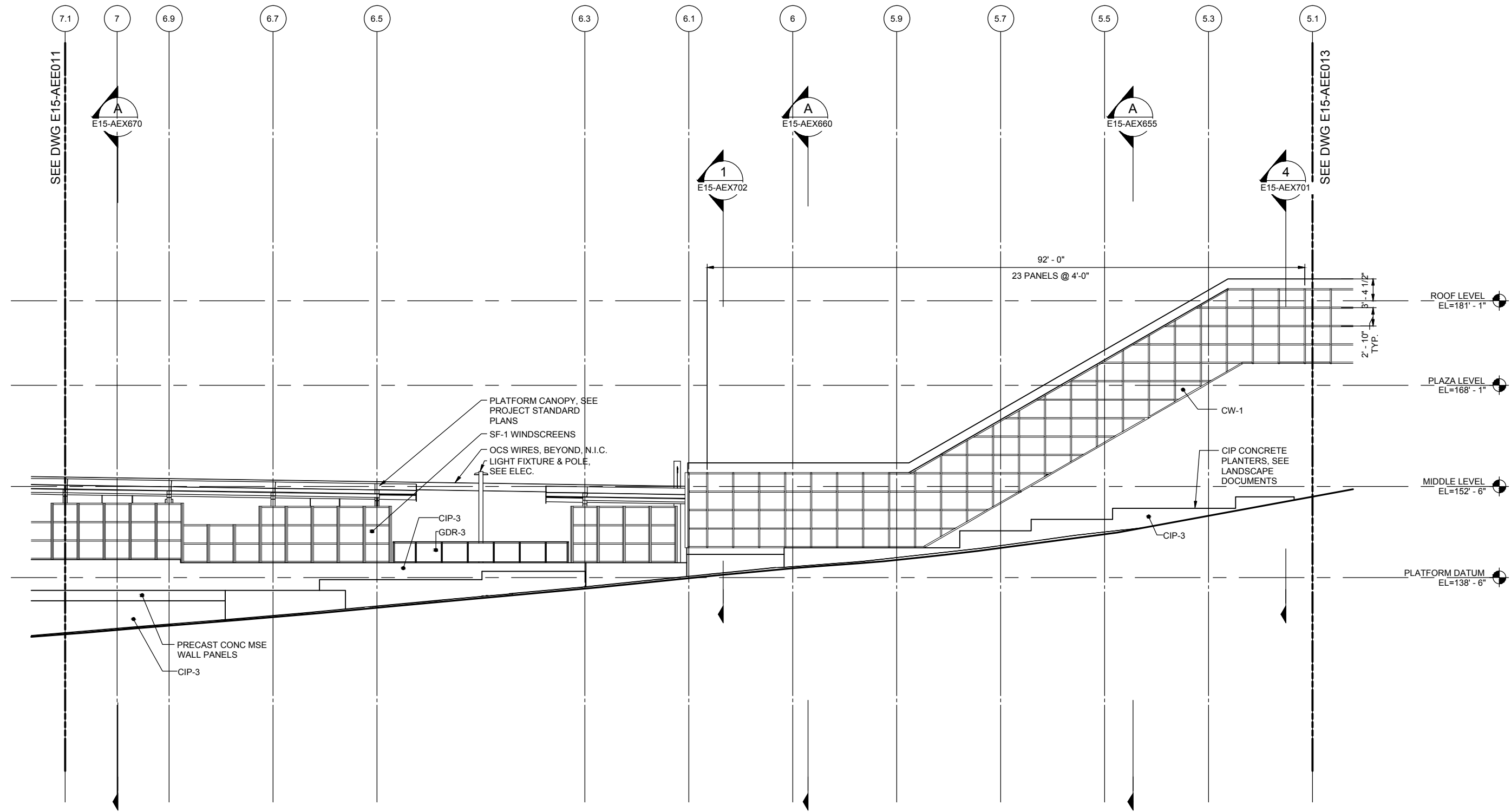

EXTERIOR ELEVATION - NORTH - CENTRAL SECTOR
 SCALE: 1/8" = 1'-0"
 A
 E15-AEE012
 E15-AEE010

60% SUBMITTAL

DESIGNED BY:
M. REDDINGTON
 DRAWN BY:
E. NOTHDURFT
 CHECKED BY:
H. FITZPATRICK
 APPROVED BY:
J. SCHUTT

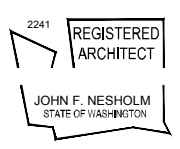

LINE IS 1" AT FULL SCALE



SCALE:
 1/8" = 1'-0"
 FILENAME:
E335-E15-AEE012
 CONTRACT No.:
RTA/LR XXXX-XX
 DATE:
12/20/2013

**EAST LINK EXTENSION
 CONTRACT E335**
 DOWNTOWN BELLEVUE TO SPRING DISTRICT
 BTC STATION
 EXTERIOR ELEVATIONS
 NORTH - CENTRAL

DRAWING No.: E15-AEE012	
LOCATION ID: E15	
SHEET No.:	REV:
	0

XREF LIST:
 XE335-GB-TB22x34
 XE335-E15-AEE010
 GB-SEAL-JFN2241

ORIGINATED BY: / DATE: /
 CHECKED BY: / DATE: /
 CORRECTED BY: / DATE: /
 VERIFIED BY: / DATE: /
 11/22/13 | 11:30 AM | CALDWELL
 C:\USERS\PUBLIC\DOCUMENTS\CALDWELL\PROJECTS\SHARPOINT\SOUNDTRANSIT\ORG\443\SITES\CAD\EL\BEL\RED\E335\DRAWINGS\E15-AEE013.DWG

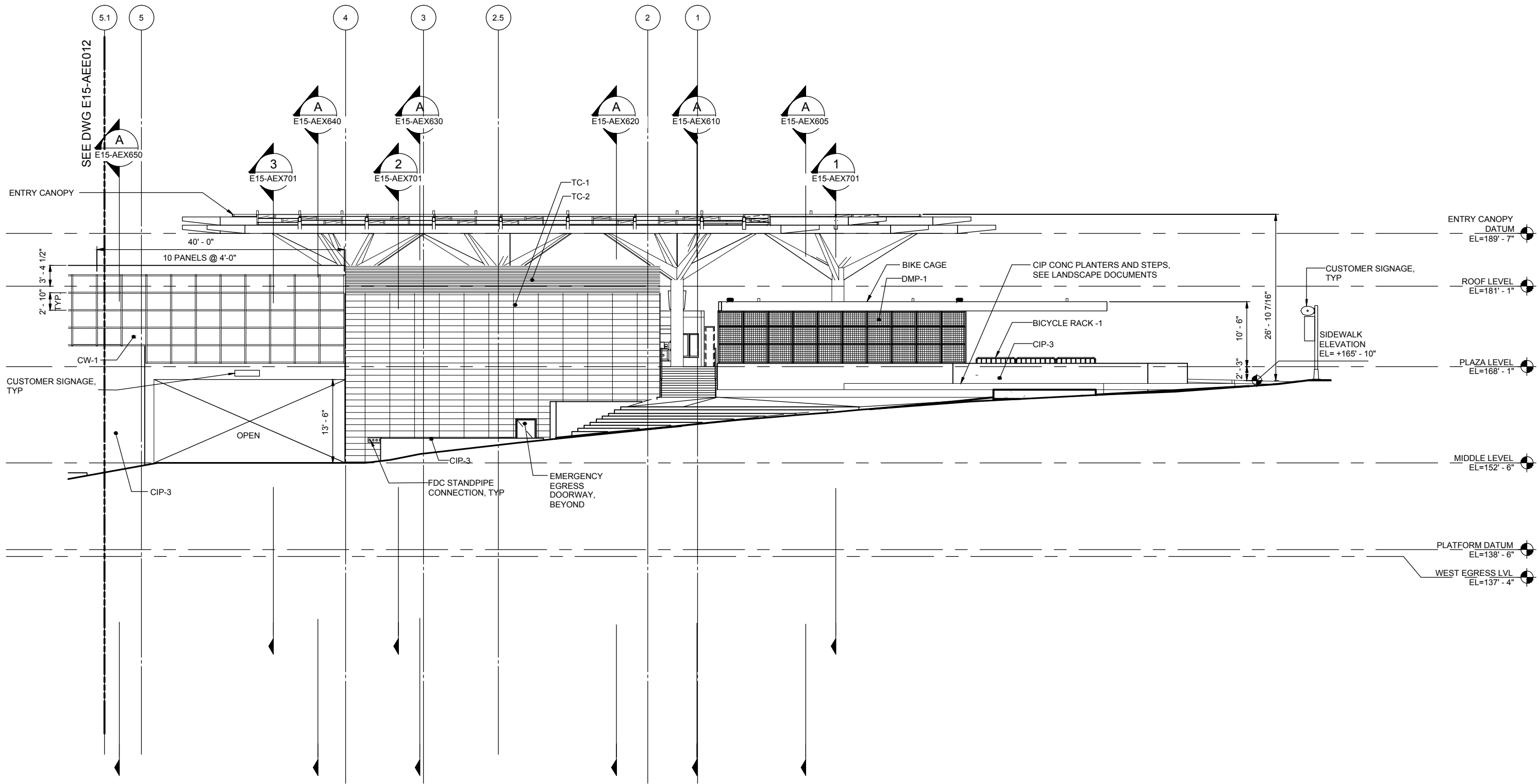

EXTERIOR ELEVATION - NORTH - WEST SECTOR
 SCALE: 1/8" = 1'-0"

A
 E15-AEE013
 E15-AEE010

60% SUBMITTAL

DESIGNED BY:
M. REDDINGTON
 DRAWN BY:
E. NOTHDURFT
 CHECKED BY:
H. FITZPATRICK
 APPROVED BY:
J. SCHUTT

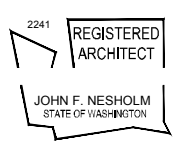

LINE IS 1" AT FULL SCALE



SCALE:
 1/8" = 1'-0"
 FILENAME:
 E335-E15-AEE013
 CONTRACT No.:
 RTA/LR XXXX-XX
 DATE:
 12/20/2013

**EAST LINK EXTENSION
 CONTRACT E335**
 DOWNTOWN BELLEVUE TO SPRING DISTRICT
 BTC STATION
 EXTERIOR ELEVATIONS
 NORTH - WEST

DRAWING No.:
E15-AEE013
 LOCATION ID:
E15
 SHEET No.:
 REV:
0

XREF LIST:
 XE335-L86-CAP100
 XE335-L86-CLP100
 XE335-L86-CMP100
 XE335-L86-KAP100
 XE335-E15-APP100
 XE335-E15-APP400
 XEL-0228r
 XEL-0228f
 XEL-0228u
 XEL-0228v
 XE335-E15-LSP100
 XE335-L86-CRP100
 XE335-L86-UCP100
 XE335-L86-LPP100
 XE335-E15-APP500
 XE335-L86-CPD100
 XE335-L86-CPP100
 XE335-L86-JEP100
 XE335-L86-RPP100
 XE335-L86-SFP100
 GB-SEAL_SBVB57
 XE335-E15-APP300
 XE335-L86-CPD100
 XE335-GB-TR22x34
 XEL-0228v
 XEL-0228u
 XEL-0228v
 XEL-0228u
 XE335-E15-ELP100
 XE335-E15-ELP400
 XE335-L86-TSP100
 XE335-E15-ANP400

ORIGINATED BY: / DATE: /
 CORRECTED BY: / DATE: /
 CHECKED BY: / DATE: /
 VERIFIED BY: / DATE: /
 11/22/13 1:31 PM | CALDWELL
 BACK-CHECKED BY: / DATE: /
 C:\USERS\PUBLIC\DOCUMENTS\CALDWELL\H\TTPS\SHAREPOINT\SOUNDTRANSIT\ORG\443\SITES\CAD\ELBEL\RED\E335\DRAWINGS\E15-LSP101.DWG

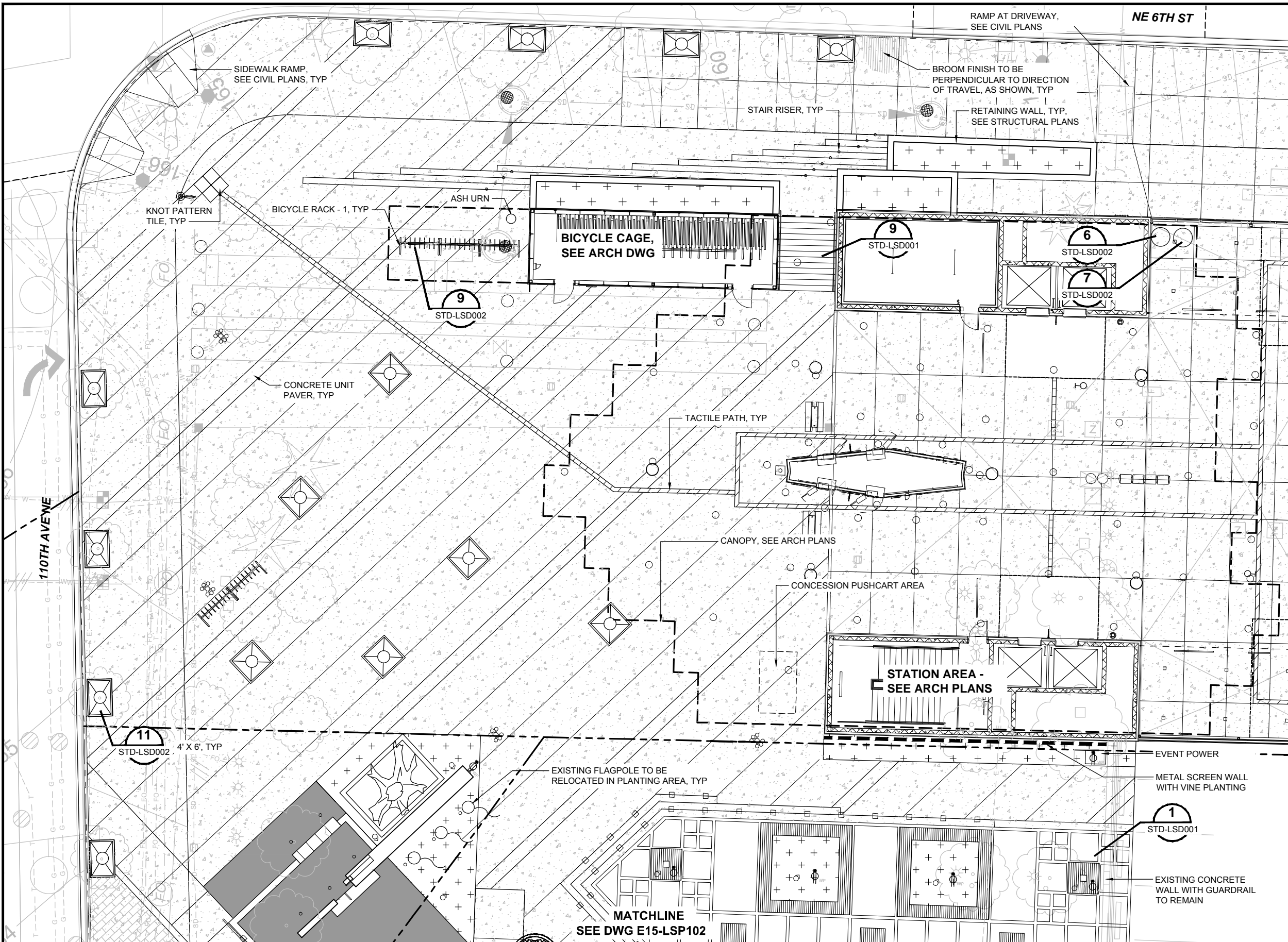

LEGEND

- PLANTING AREA - SEE PLANTING PLAN
- CONCRETE PAVING
- TACTILE PATH AND KNOT PATTERN TILE
- CONCRETE CONTROL JOINT

1 STD-LSD001
 3 STD-LSD001

MATCHLINE
SEE DWG E15-LSP103



60% SUBMITTAL

DESIGNED BY:
J. YONG
 DRAWN BY:
R. DOTSON
 CHECKED BY:
D. KOONTS
 APPROVED BY:
J. SCHUTT



HBB
 LANDSCAPE ARCHITECTURE
 715 WEST BOND AVENUE NORTH SEATTLE, WA 98107
 206.623.2046 206.692.2245 WA

H J H
 FINAL DESIGN PARTNERS.

SOUNDTRANSIT

SCALE:
1/8"=1'-0"
 FILENAME:
E335-E15-LSP101
 CONTRACT No.:
RTA/LR XXXX-XX
 DATE:
12/20/2013

**EAST LINK EXTENSION
 CONTRACT E335**
 DOWNTOWN BELLEVUE TO SPRING DISTRICT
 BTC STATION
 LANDSCAPE
 HARDSCAPE PLAN - WEST SEGMENT 1

DRAWING No.:
E15-LSP101
 LOCATION ID:
E15
 SHEET No.: REV:
0

No.	DATE	DSN	CHK	APP	REVISION

XREF LIST:
 XE335-L86-CAP100
 XE335-L86-CLP100
 XE335-L86-CMP100
 XE335-L86-KAP100
 XE335-E15-APP100
 XE335-E15-APP400
 XE1-0528f
 XE1-0528g
 XE335-E15-LSP100
 XE335-L86-CRP100
 XE335-L86-UCP100
 XE335-L86-LPP100
 XE335-L86-CGP100
 XE335-L86-CPP100
 XE335-L86-EP100
 XE335-L86-SPP100
 GB-SEAL-JBVB87
 XE335-L86-CCP100
 XE335-GB-TB22X34
 XE335-E15-ELP100
 XE1-0528d
 XE335-E15-ANP100
 XE335-E15-ANP200

ORIGINATED BY: / DATE: /
 CHECKED BY: / DATE: /
 BACK-CHECKED BY: / DATE: /
 11/22/13 1:33 PM | CALDWELL
 C:\USERS\PUBLIC\DOCUMENTS\CALDWELL\H\TTPS\SHAREPOINT\SOUNDTRANSIT\ORG\443\SITES\CAD\EL\RED\E335\DRAWINGS\E15-LSP104.DWG

DESIGNED BY: J. VONG
 DRAWN BY: R. DOTSON
 CHECKED BY: D. KOONTS
 APPROVED BY: J. SCHUTT



SCALE: 1/8"=1'-0"
 FILENAME: E335-E15-LSP104
 CONTRACT No.: RTA/LR XXXX-XX
 DATE: 12/20/2013

EAST LINK EXTENSION
CONTRACT E335
 DOWNTOWN BELLEVUE TO SPRING DISTRICT
 BTC STATION
 LANDSCAPE
 HARDSCAPE PLAN - EAST SEGMENT

DRAWING No.: E15-LSP104
 LOCATION ID: E15
 SHEET No.: REV: 0

MATCHLINE
 SEE DWG E15-LSP103

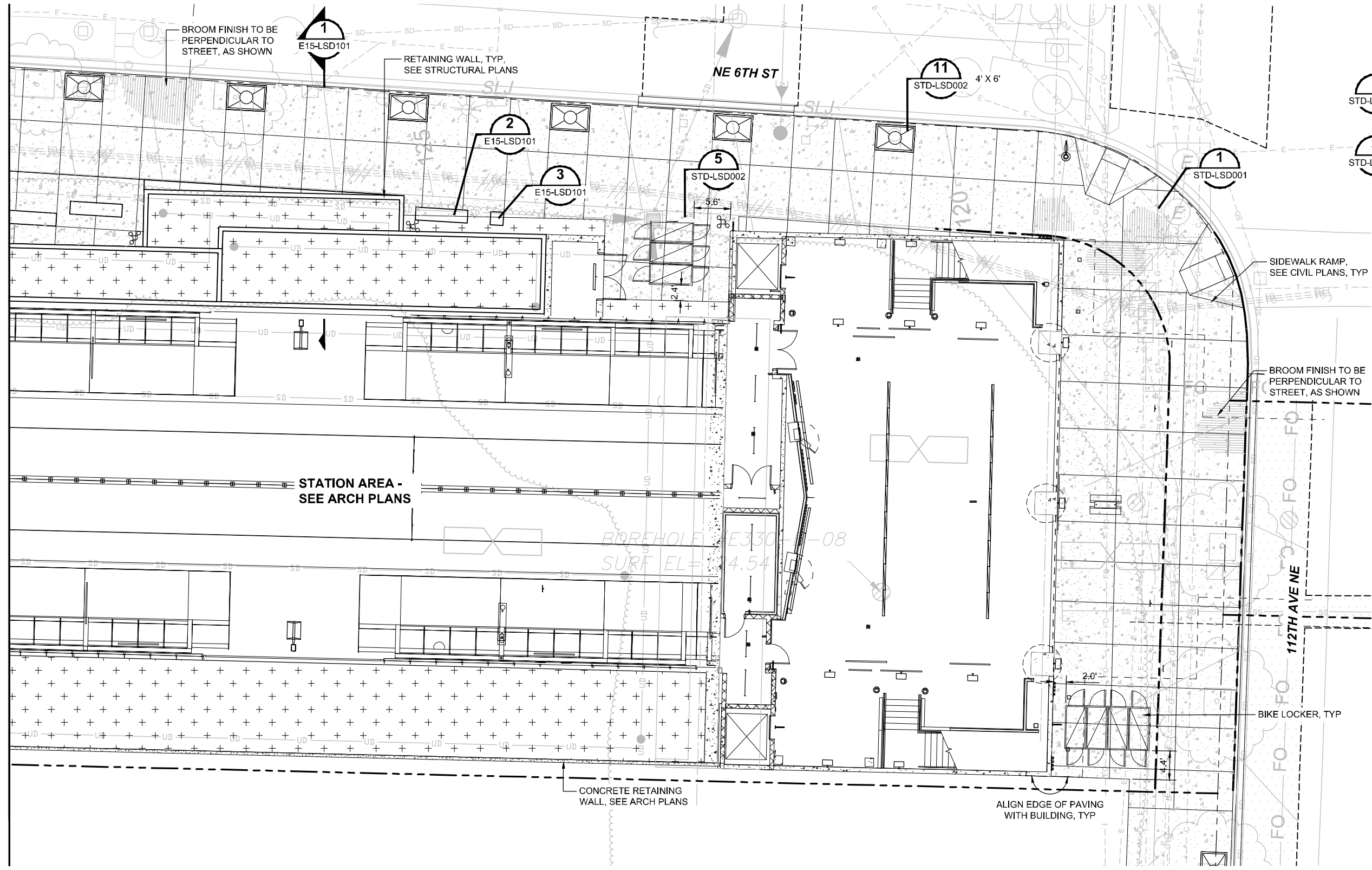

LEGEND

- PLANTING AREA - SEE PLANTING PLAN
- CONCRETE PAVING
- TACTILE PATH AND KNOT PATTERN TILE
- CONCRETE CONTROL JOINT



XREF LIST:
 XE335-08-TB22x34
 XE335-E19-APP100
 XE335-E19-LSP100
 XE335-E19-LPP100
 XE335-L86-CRP100
 CB-SEAL-K-KR153
 XE335-E19-SFP100
 XE335-E19-AZV096
 XE335-E19-SFP200

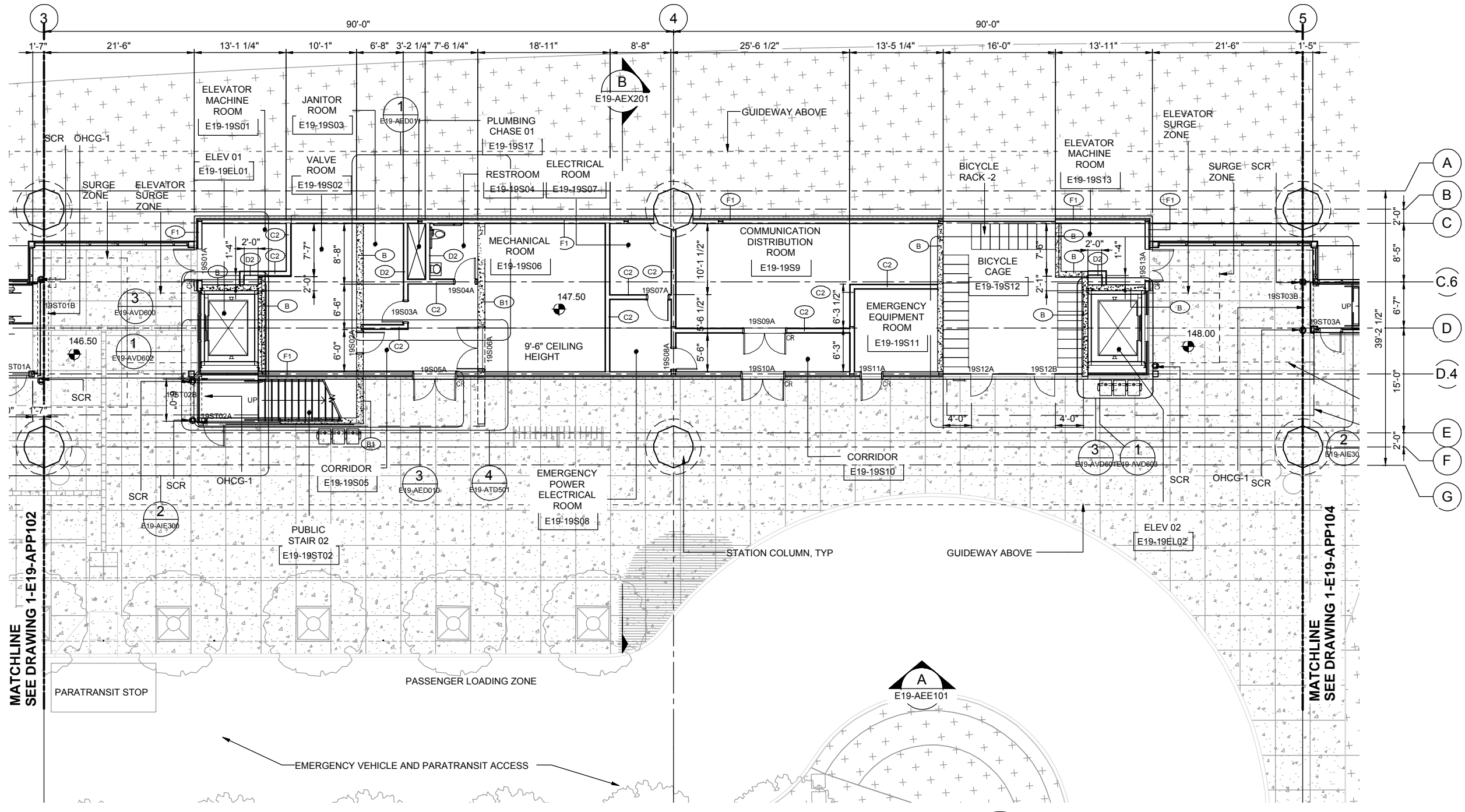

FLOOR PLAN - PLAZA LEVEL - CENTER
 SCALE: 1/8" = 1'-0"
 1
 E19-APP103

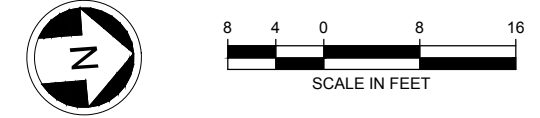

ORIGINATED BY: / DATE: /
 CHECKED BY: / DATE: /
 BACK-CHECKED BY: / DATE: /
 12/21/13 11:18 AM | HOSEKY
 C:\USERS\PUBLIC\DOCUMENTS\HOSEKY\HOSPITAL\HOSPITAL\DRAWINGS\E335-E19-APP103.DWG

CORRECTED BY: / DATE: /
 VERIFIED BY: / DATE: /

60% SUBMITTAL

DESIGNED BY:
J. DOBLE
 DRAWN BY:
A. CHMIEL
 CHECKED BY:
L. LELAND
 APPROVED BY:
J. SCHUTT

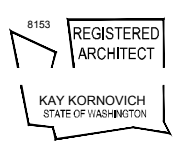

SCALE:
1/8" = 1'-0"
 FILENAME:
E335-E19-APP103
 CONTRACT No.:
RTA/LR XXXX-XX
 DATE:
12/20/2013

**EAST LINK EXTENSION
 CONTRACT E335**
 DOWNTOWN BELLEVUE TO SPRING DISTRICT
 HOSPITAL STATION
 PLAN
 STATION-PLAZA LEVEL PLAN CENTRAL

DRAWING No.:
E19-APP103
 LOCATION ID:
E19
 SHEET No.: REV:
0

XREF LIST:
 XE335-GB-TB22x34
 GB-SEAL-K-K0153
 XE335-E19-APP200
 XE335-L86-SGP100
 XE335-E19-SGP300
 XE335-E19-SGP200
 XE335-E19-AZV096

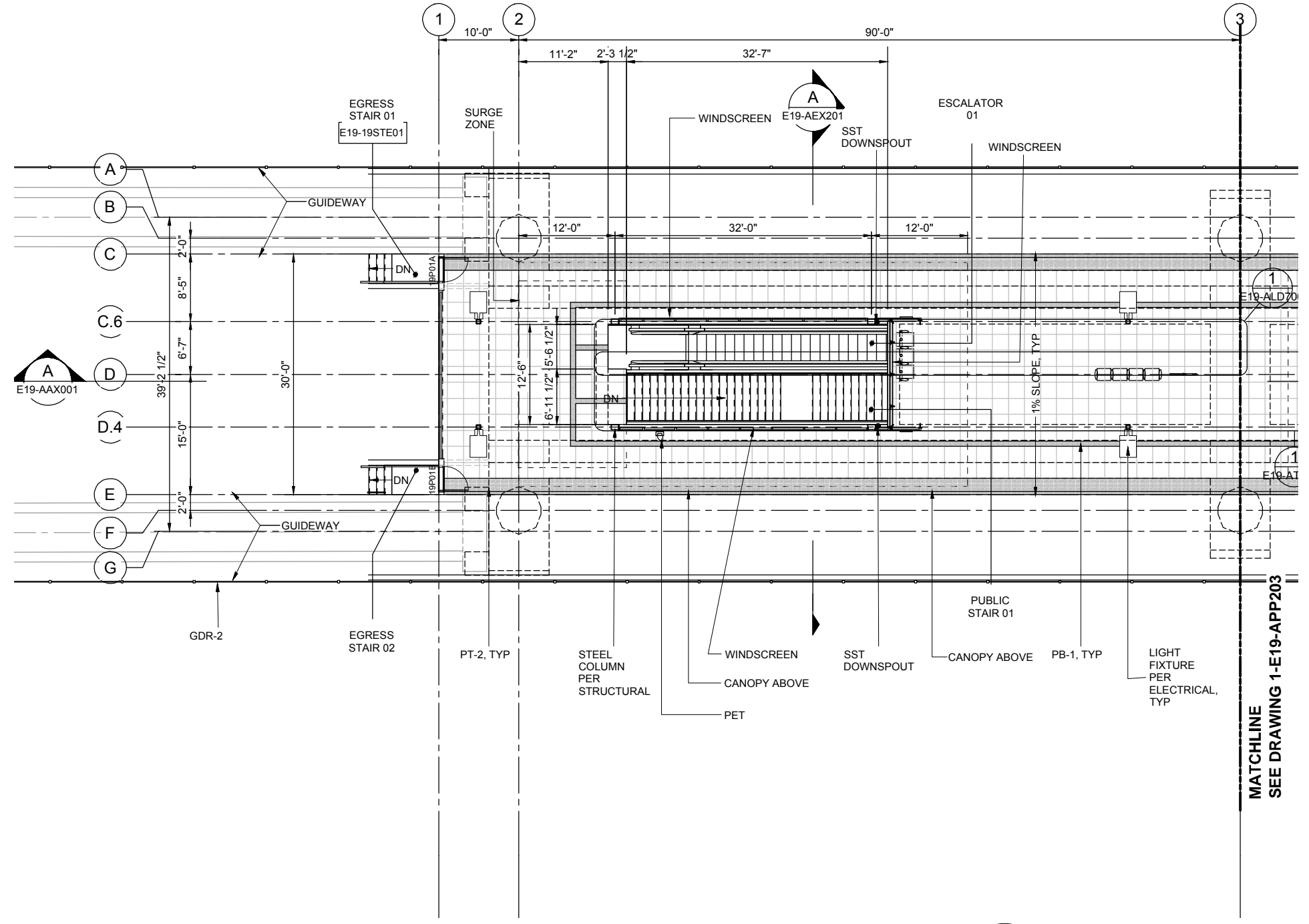

FLOOR PLAN - PLATFORM LEVEL - SOUTH
 SCALE: 1/8" = 1'-0"

1
E19-APP202

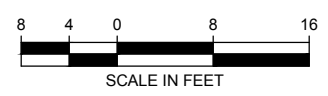

MATCHLINE
SEE DRAWING 1-E19-APP203

ORIGINATED BY: / DATE: /
 CHECKED BY: / DATE: /
 CORRECTED BY: / DATE: /
 VERIFIED BY: / DATE: /
 12/09/13 | 12:27 PM | CALDWELL
 C:\USERS\PUBLIC\DOCUMENTS\CALDWELL\H\TTPS\SHAREPOINT\SOUNDTRANSIT\ORG\443\SITES\CAD\ELBEL\RED\E335DRAWINGS\E335-E19-APP202.DWG

60% SUBMITTAL

DESIGNED BY:
J. DOBLE
 DRAWN BY:
A. CHMIEL
 CHECKED BY:
L. LELAND
 APPROVED BY:
J. SCHUTT

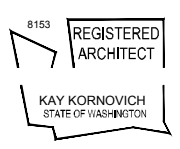

LINE IS 1" AT FULL SCALE



SCALE:
1/8" = 1'-0"
 FILENAME:
E335-E19-APP202
 CONTRACT No.:
RTA/LR XXXX-XX
 DATE:
12/20/2013

**EAST LINK EXTENSION
 CONTRACT E335**
 DOWNTOWN BELLEVUE TO SPRING DISTRICT
 HOSPITAL STATION
 PLAN
 STATION-PLATFORM PLAN SOUTH

DRAWING No.:
E19-APP202
 LOCATION ID:
E19
 SHEET No.: REV:
0

XREF LIST:
 XE335-GB-TB22x34
 GB-SEAL-K-K0153
 XE335-E19-APP200
 XE335-L86-SGP100
 XE335-E19-SGP300
 XE335-E19-SGP200
 XE335-E19-AZV096

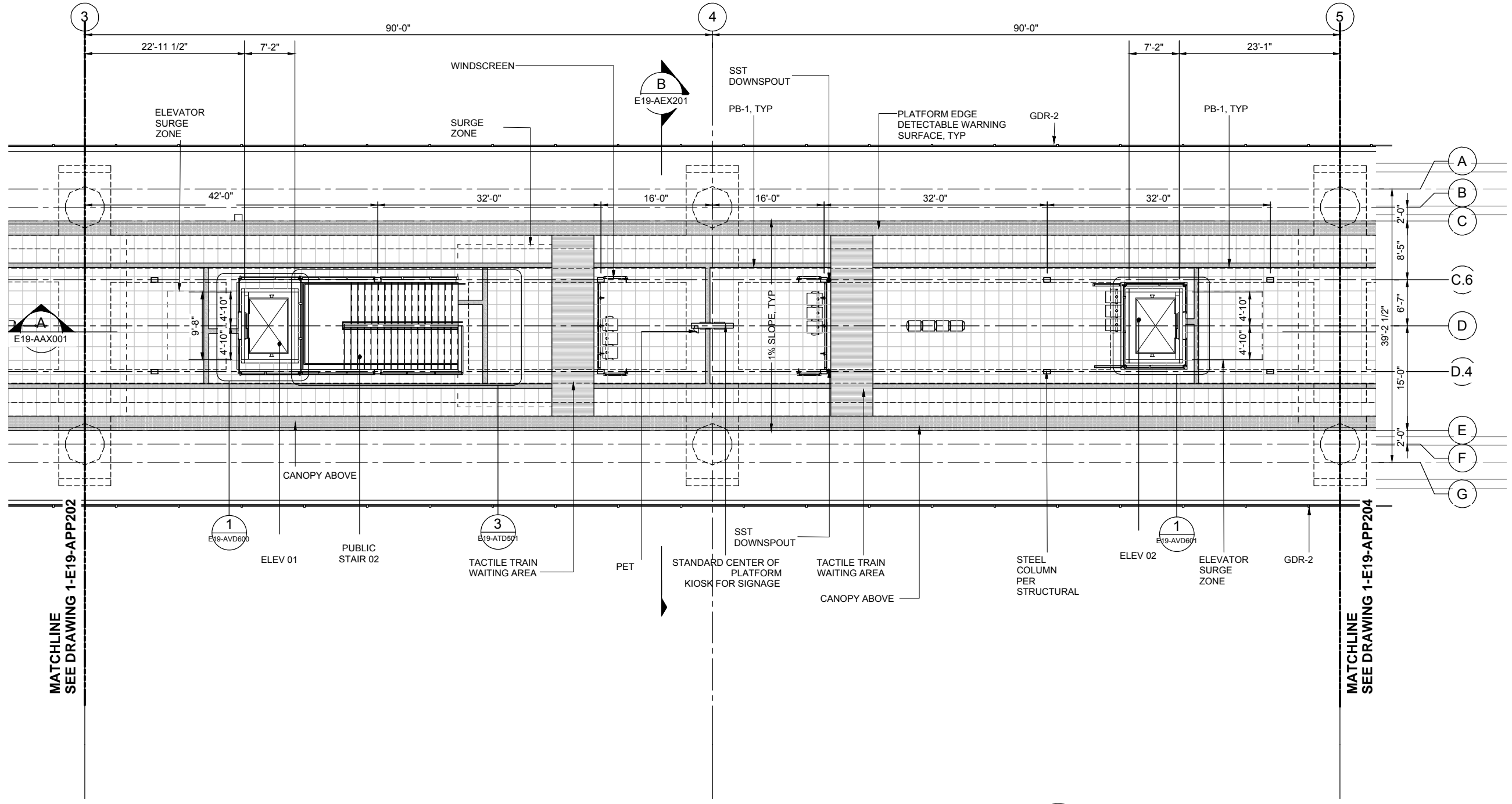

FLOOR PLAN - PLATFORM LEVEL - CENTRAL
 SCALE: 1/8" = 1'-0"

1
 E19-APP203

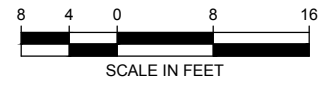

ORIGINATED BY: / DATE: /
 CHECKED BY: / DATE: /
 CORRECTED BY: / DATE: /
 VERIFIED BY: / DATE: /
 12/09/13 | 12:27 PM | CALDWELL
 C:\USERS\PUBLIC\DOCUMENTS\CALDWELL\H\TTPS\SHAREPOINT\SOUNDTRANSIT\ORG\443\SITES\CAD\ELBEL\RED\E335-E19-APP203.DWG

60% SUBMITTAL

DESIGNED BY:
 J. DOBLE
 DRAWN BY:
 A. CHMIEL
 CHECKED BY:
 L. LELAND
 APPROVED BY:
 J. SCHUTT

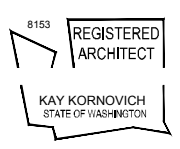

SUBMITTED BY:
 DATE:
 REVIEWED BY:
 DATE:



SCALE:
 1/8" = 1'-0"
 FILENAME:
 E335-E19-APP203
 CONTRACT No.:
 RTA/LR XXXX-XX
 DATE:
 12/20/2013

EAST LINK EXTENSION
 CONTRACT E335
 DOWNTOWN BELLEVUE TO SPRING DISTRICT
 HOSPITAL STATION
 PLAN
 STATION-PLATFORM PLAN CENTRAL

DRAWING No.:
 E19-APP203
 LOCATION ID:
 E19
 SHEET No.:
 REV:
 0

XREF LIST:
 XE335-GB-TB22x34
 GB-SEAL-K-KB153
 XE335-E19-APP200
 XE335-L86-SGP100
 XE335-E19-SGP300
 XE335-E19-SGP200
 XE335-E19-AZV096

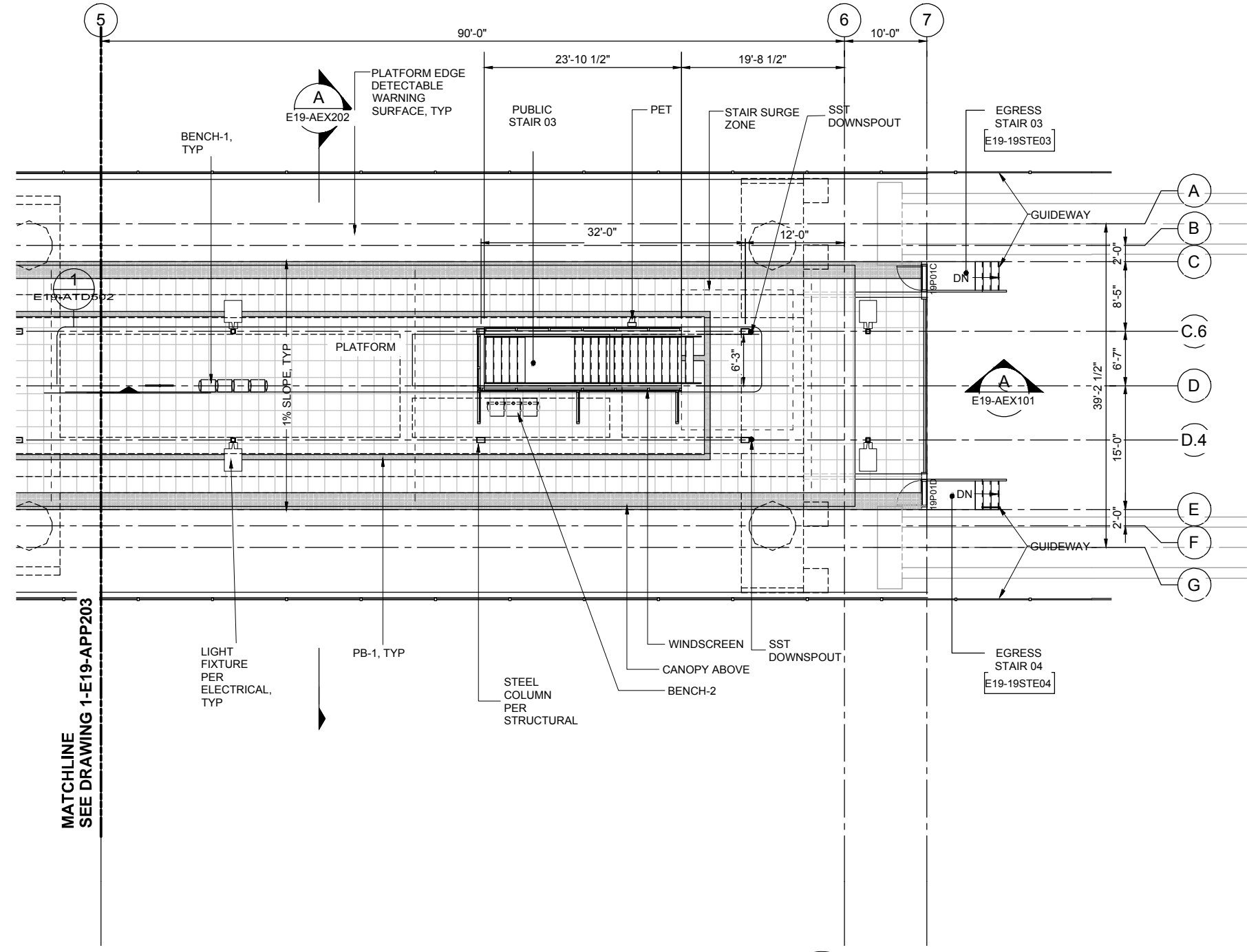

FLOOR PLAN - PLATFORM LEVEL - NORTH
 SCALE: 1/8" = 1'-0"

1
 E19-APP204

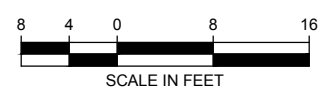

ORIGINATED BY: / DATE: /
 CHECKED BY: / DATE: /
 CORRECTED BY: / DATE: /
 VERIFIED BY: / DATE: /
 12/09/13 | 12:27 PM | CALDWELL
 C:\USERS\PUBLIC\DOCUMENTS\CALDWELL\H\TTPS\SHAREPOINT\SOUNDTRANSIT\ORG\443\SITES\CAD\ELBEL\RED\E335\E19-APP204.DWG

60% SUBMITTAL

DESIGNED BY:
 J. DOBLE
 DRAWN BY:
 A. CHMIEL
 CHECKED BY:
 L. LELAND
 APPROVED BY:
 J. SCHUTT

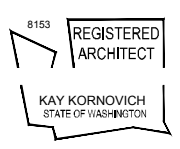

LINE IS 1" AT FULL SCALE



SCALE:
 1/8" = 1'-0"
 FILENAME:
 E335-E19-APP204
 CONTRACT No.:
 RTA/LR XXXX-XX
 DATE:
 12/20/2013

EAST LINK EXTENSION
 CONTRACT E335
 DOWNTOWN BELLEVUE TO SPRING DISTRICT
 HOSPITAL STATION
 PLAN
 STATION-PLATFORM PLAN NORTH

DRAWING No.:
 E19-APP204
 LOCATION ID:
 E19
 SHEET No.: REV:
 0

XREF LIST:
 XE335-GB-TB22x34
 GB-SEAL-K_K8153

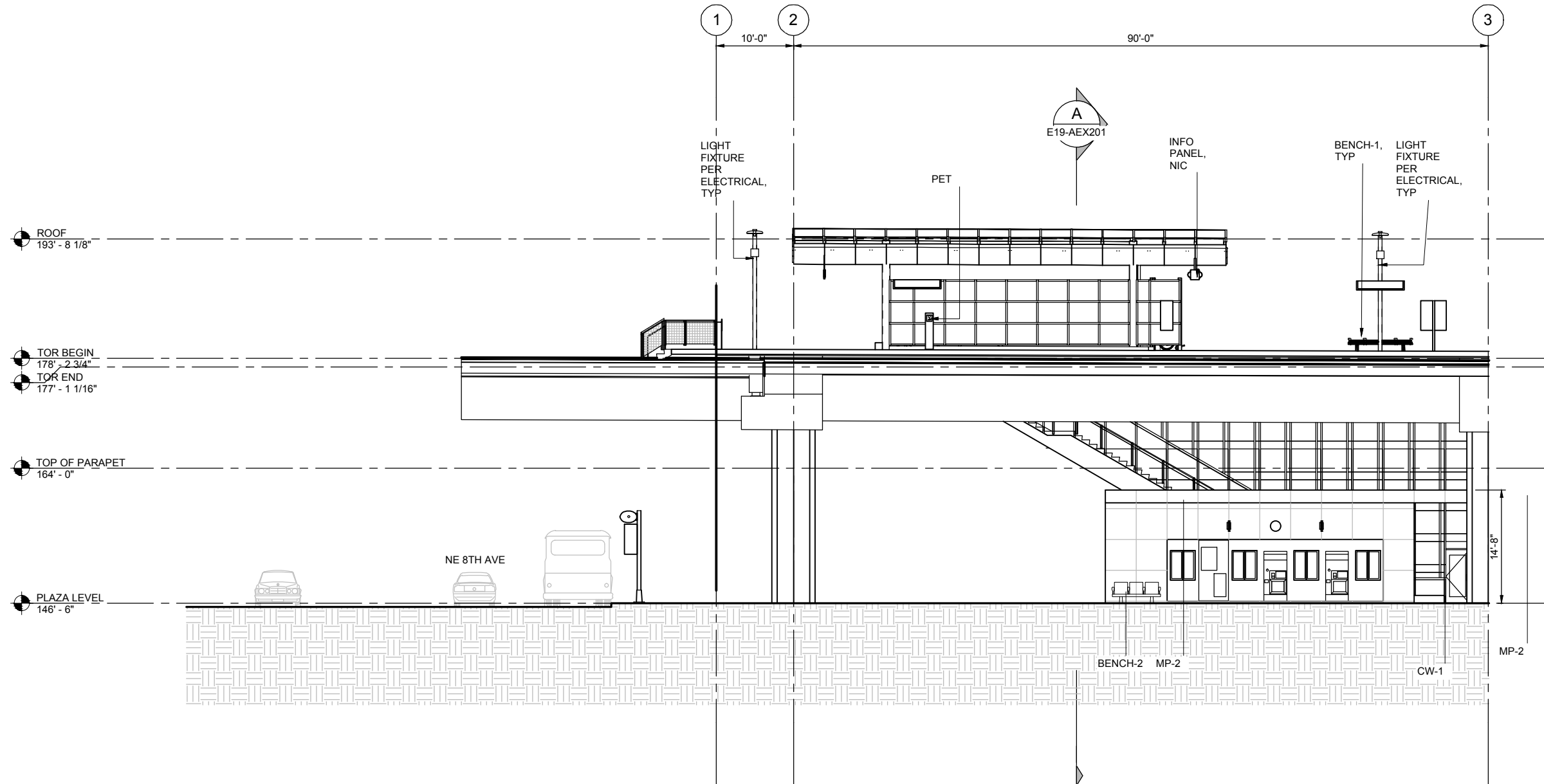

EAST ELEVATION - SOUTH

SCALE: 1/8" = 1'-0"

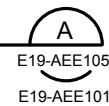

E19-AEE105

E19-AEE101

ORIGINATED BY: / DATE: /
 CHECKED BY: / DATE: /
 CORRECTED BY: / DATE: /
 BACK-CHECKED BY: / DATE: /
 VERIFIED BY: / DATE: /
 12/09/13 | 1:24 PM | CALDWELL
 C:\USERS\PUBLIC\DOCUMENTS\CALDWELL\H\TTPS\SHAREPOINT\SOUNDTRANSIT\ORG\443\SITES\CAD\ELIBEL\RED\E335\E19-AEE105.DWG

60% SUBMITTAL

DESIGNED BY:
J. DOBLE
 DRAWN BY:
A. CHMIEL
 CHECKED BY:
L. LELAND
 APPROVED BY:
J. SCHUTT

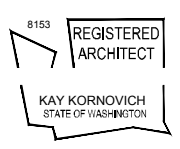

LINE IS 1" AT FULL SCALE



SCALE:
1/8" = 1'-0"
 FILENAME:
E335-E19-AEE105
 CONTRACT No.:
RTA/LR XXXX-XX
 DATE:
12/20/2013

EAST LINK EXTENSION
 CONTRACT E335
 DOWNTOWN BELLEVUE TO SPRING DISTRICT
 HOSPITAL STATION
 ELEV
 STATION-EAST ELEVATION SOUTH

DRAWING No.:
E19-AEE105
 LOCATION ID:
E19
 SHEET No.: REV:
0

No.	DATE	DSN	CHK	APP	REVISION

XREF LIST:
 XE335-GB-TB22x34
 GB-SEAL-K_K8153

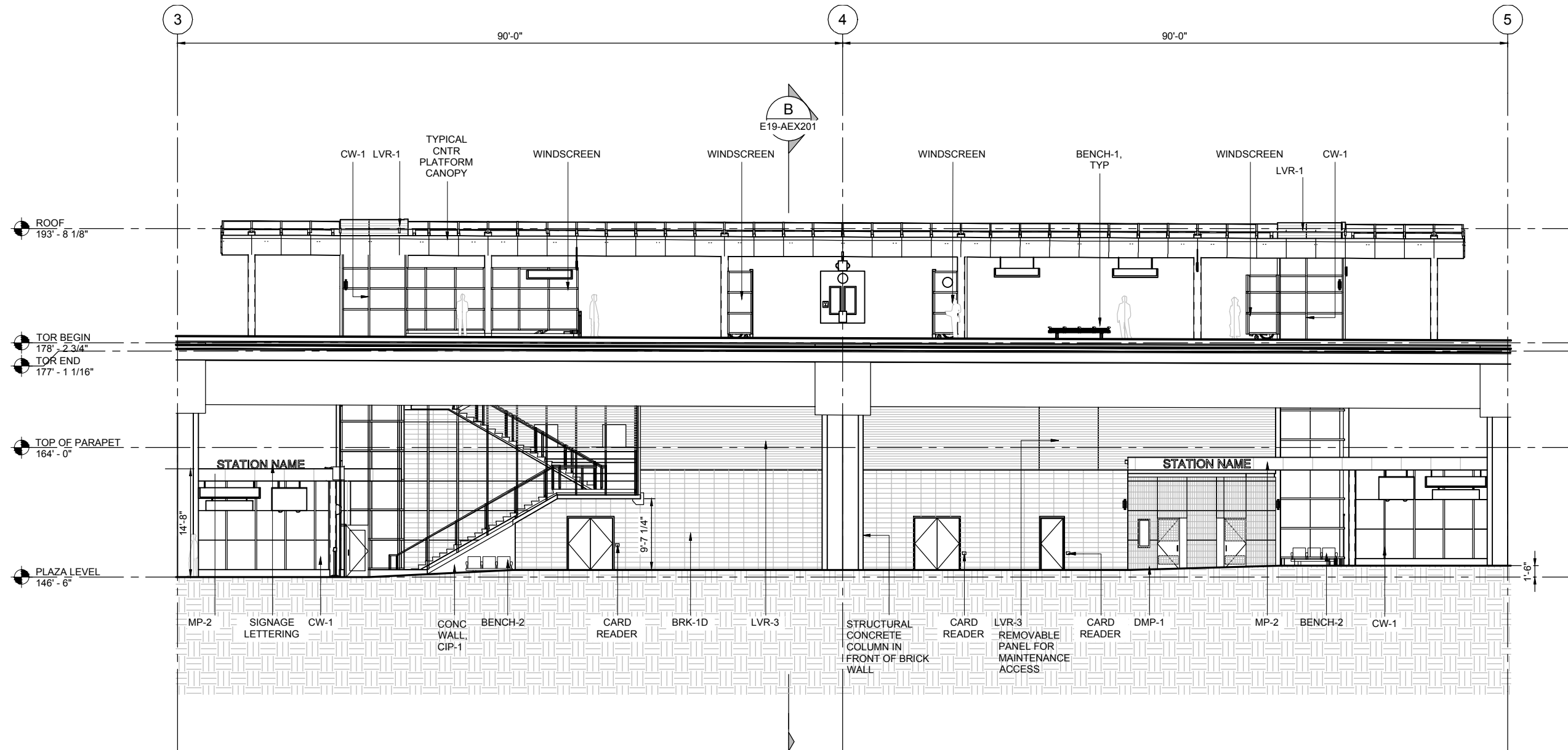

EAST ELEVATION - CENTRAL

SCALE: 1/8" = 1'-0"

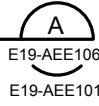

ORIGINATED BY: / DATE: /
 CHECKED BY: / DATE: /
 BACK-CHECKED BY: / DATE: /
 12/09/13 | 1:24 PM | CALDWELL
 C:\USERS\PUBLIC\DOCUMENTS\CALDWELL\H\TTPS\SHARPOINT\SOUNDTRANSIT\ORG\443\SITES\CAD\ELBEL\RED\E335\E19-AEE106.DWG

CORRECTED BY: / DATE: /
 VERIFIED BY: / DATE: /

60% SUBMITTAL					
No.	DATE	DSN	CHK	APP	REVISION

DESIGNED BY:
J. DOBLE
 DRAWN BY:
A. CHMIEL
 CHECKED BY:
L. LELAND
 APPROVED BY:
J. SCHUTT

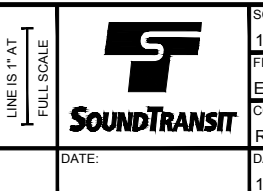
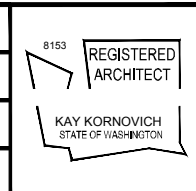

SCALE:
1/8" = 1'-0"
 FILENAME:
E335-E19-AEE106
 CONTRACT No.:
RTA/LR XXXX-XX
 DATE:
12/20/2013

EAST LINK EXTENSION
CONTRACT E335
 DOWNTOWN BELLEVUE TO SPRING DISTRICT
 HOSPITAL STATION
 ELEV
 STATION-EAST ELEVATION CENTRAL

DRAWING No.:	E19-AEE106
LOCATION ID:	E19
SHEET No.:	0

XREF LIST:
 E335-GB-TB22x34
 GB-SEAL-K_K8153

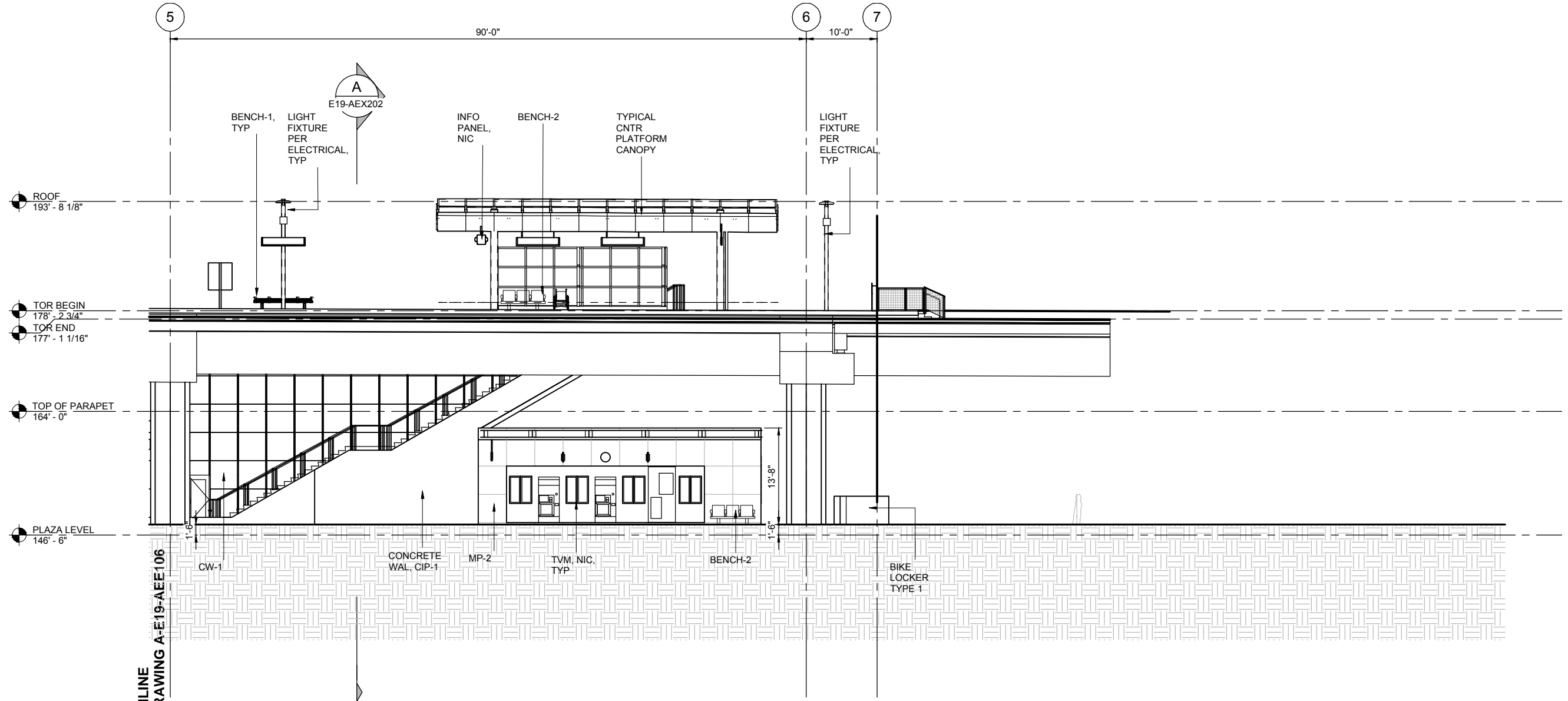

MATCHLINE
SEE DRAWING A-E19-AEE106

EAST ELEVATION - NORTH

SCALE: 1/8" = 1'-0"

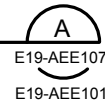

ORIGINATED BY: / DATE: /
 CHECKED BY: / DATE: /
 CORRECTED BY: / DATE: /
 BACK-CHECKED BY: / DATE: /
 VERIFIED BY: / DATE: /
 12/09/13 | 1:24 PM | CALDWELL
 C:\USERS\PUBLIC\DOCUMENTS\CALDWELL\HITTPS\SHAREPOINT\SOUNDTRANSIT\ORG\443\SITES\CAD\ELIBEL\RED\E335\E19-AEE107.DWG

60% SUBMITTAL					
No.	DATE	DSN	CHK	APP	REVISION

DESIGNED BY:
J. DOBLE
 DRAWN BY:
A. CHMIEL
 CHECKED BY:
L. LELAND
 APPROVED BY:
J. SCHUTT

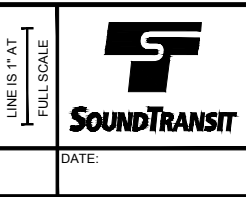
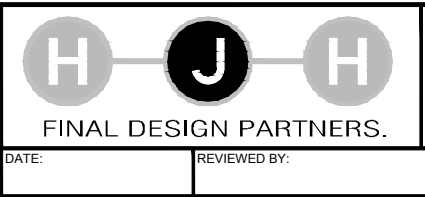
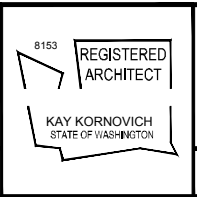

SCALE:
1/8" = 1'-0"
 FILENAME:
E335-E19-AEE107
 CONTRACT No.:
RTA/LR XXXX-XX
 DATE:
12/20/2013

**EAST LINK EXTENSION
 CONTRACT E335**
 DOWNTOWN BELLEVUE TO SPRING DISTRICT
 HOSPITAL STATION
 ELEV
 STATION-EAST ELEVATION NORTH

DRAWING No.:	E19-AEE107
LOCATION ID:	E19
SHEET No.:	REV: 0

XREF LIST:
 XE320-L85-CAP100
 XE320-L85-CSP100
 XE320-L85-CMP100
 XE320-L85-KAP100
 XE320-L85-SFP100
 XE320-L85-SWP100
 XE320-L85-UCP100
 XE320-L85-TB22004
 XE320-L85-LMP100
 XE320-L85-CP100
 XE320-L85-RFP100
 XE320-L85-JEP100
 XE320-L85-RFP020
 XE320-L85-RFP100
 XE320-L85-RFP100
 XE320-L85-LMP100
 XE320-L85-SWP100
 XE320-L85-TSP100
 XE320-L85-CDP100
 XE320-L85-CLP100
 XE320-L85-CLP100
 XE320-L85-CLP100

SEE DWG L85-LPP104

SEE DWG L85-LPP106

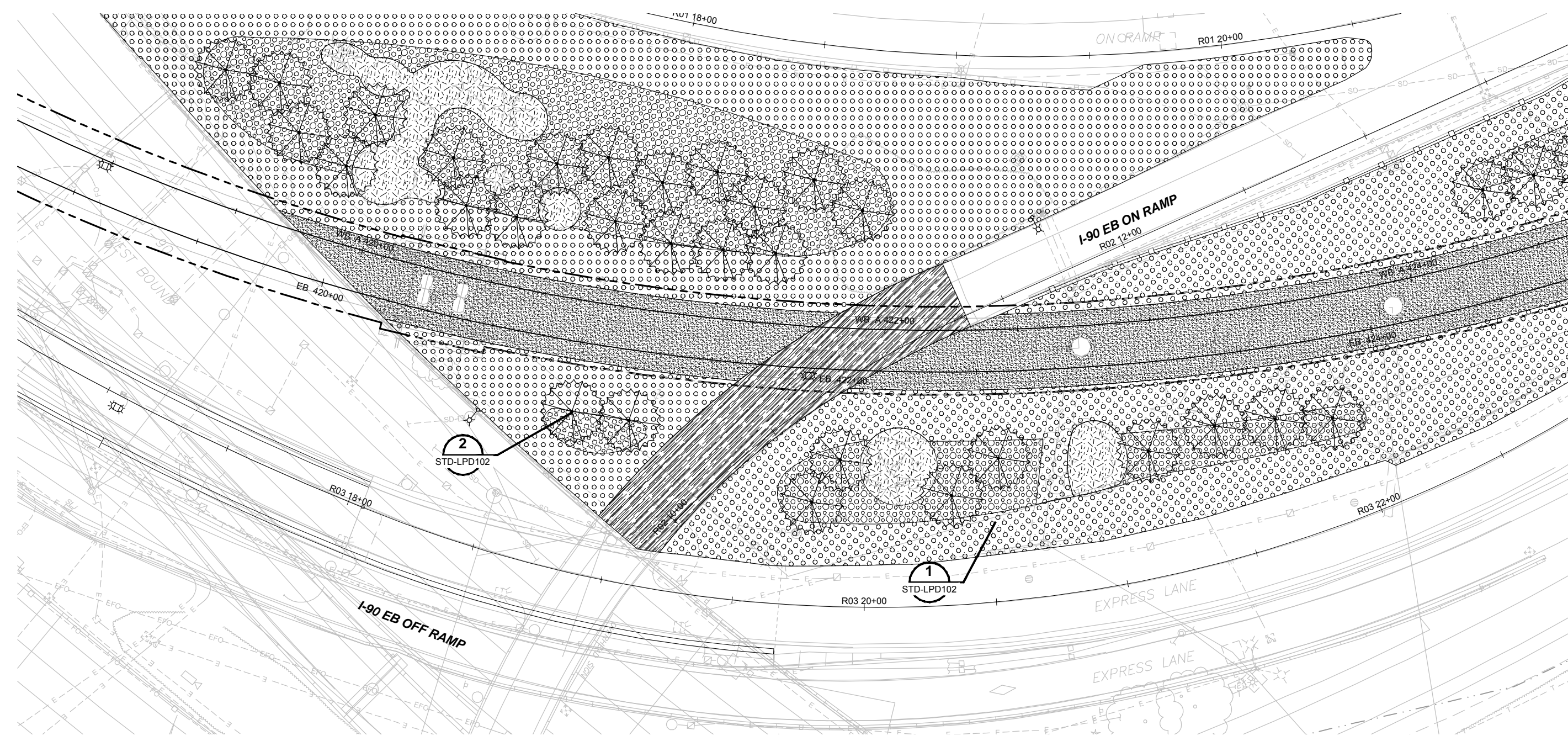

NOTES:

- SEE DWG L85-LPS100 FOR CORRIDOR PLANT SCHEDULE.

ORIGINATED BY: / DATE: /
 CHECKED BY: / DATE: /
 CORRECTED BY: / DATE: /
 VERIFIED BY: / DATE: /
 11/07/13 | 3:20 PM | CALDWELL
 C:\USERS\PUBLIC\DOCUMENTS\CALDWELL\H\TTPS\SHAREPOINT\SOUNDTRANSIT\ORG\443\SITES\CAD\EL\BEL\RED\E320\DRAWINGS\E320-L85-LPP105.DWG

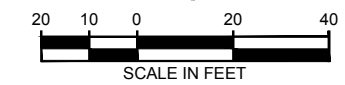

60% SUBMITTAL

DESIGNED BY:
J. VONG
 DRAWN BY:
M. OVIIR
 CHECKED BY:
D. KOONTZ
 APPROVED BY:
J. SCHESSLER

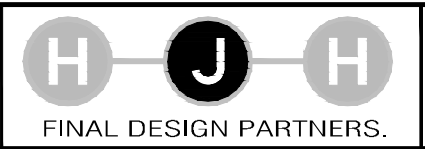

LINE IS 1" AT FULL SCALE



SCALE:
1" = 20'
 FILENAME:
E320-L85-LPP105
 CONTRACT No.:
RTA/LR XXXX-XX
 DATE:
12/06/2013

**EAST LINK EXTENSION
 CONTRACT E320
 SOUTH BELLEVUE**
 LANDSCAPE
 PLANTING PLAN
 I-90 RAMP

DRAWING No.:
L85-LPP105
 LOCATION ID:
E12
 SHEET No.: REV:
0

No.	DATE	DSN	CHK	APP	REVISION

XREF LIST:
 XE320-L85-CAP100
 XE320-L85-CM100
 XE320-L85-CM100
 XE320-L85-CM100
 XE320-L85-SPP100
 XE320-L85-SPP100
 XE320-L85-TS200
 XE320-L85-TS200
 XE320-L85-TS200
 XE320-L85-TS200
 XE320-L85-TS200
 XE320-L85-TS200
 XE320-L85-TS200
 XE320-L85-TS200
 XE320-L85-TS200
 XE320-L85-TS200
 XE320-L85-TS200

SEE DWG L85-LPP105

SEE DWG L85-LPP107

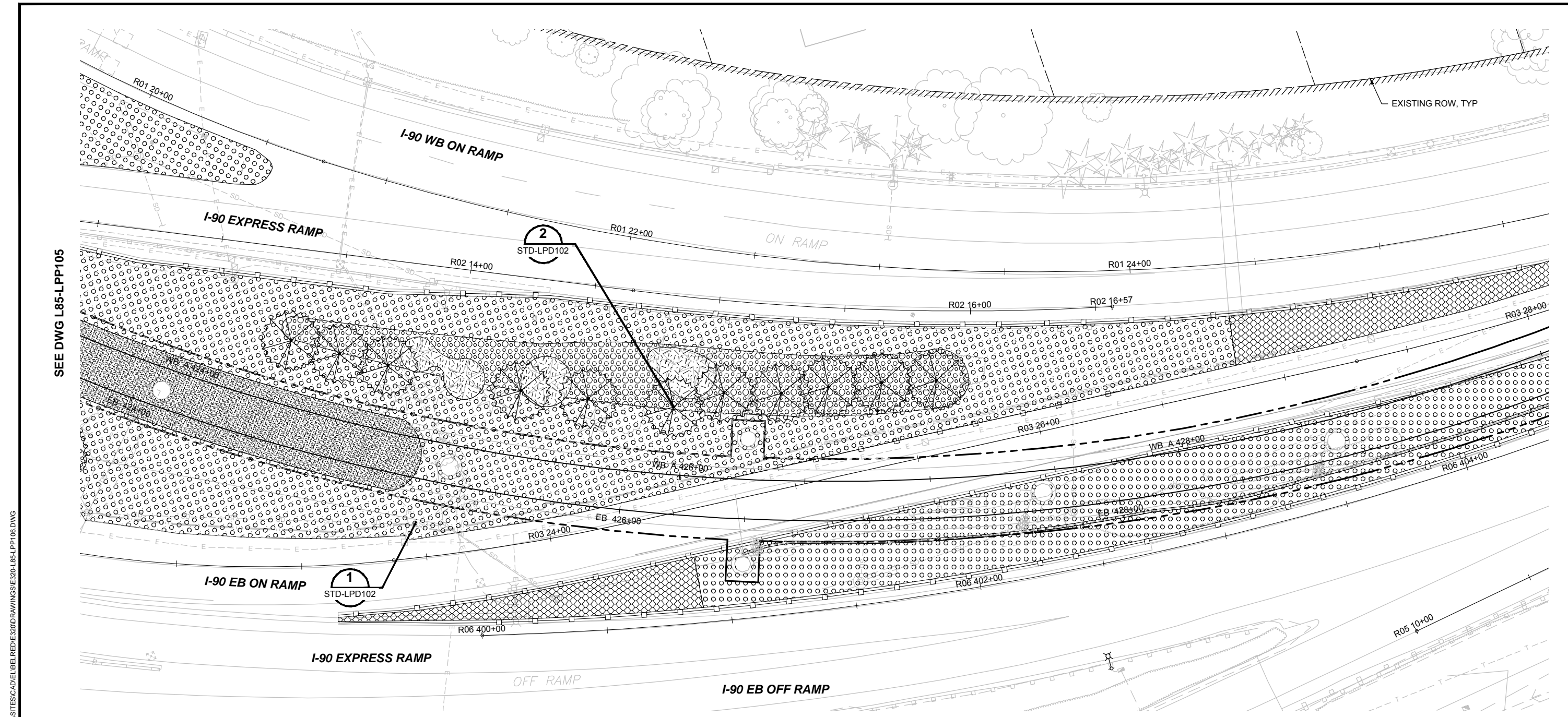

- NOTES:**
- SEE DWG L85-LPS100 FOR CORRIDOR PLANT SCHEDULE.

ORIGINATED BY: / DATE: /
 CHECKED BY: / DATE: /
 CORRECTED BY: / DATE: /
 VERIFIED BY: / DATE: /
 11/07/13 | 3:20 PM | CALDWELL
 C:\USERS\PUBLIC\DOCUMENTS\CALDWELL\HTTTPS\SHARPOIN\SOUNDTRANSIT\ORG\443\SITES\CAD\EL\BEL\RED\E320-L85-LPP106.DWG

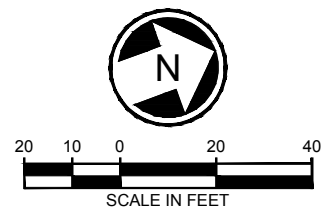

60% SUBMITTAL					
No.	DATE	DSN	CHK	APP	REVISION

DESIGNED BY:
J. YONG
 DRAWN BY:
M. OVIIR
 CHECKED BY:
D. KOONTS
 APPROVED BY:
J. SCHEITTLER

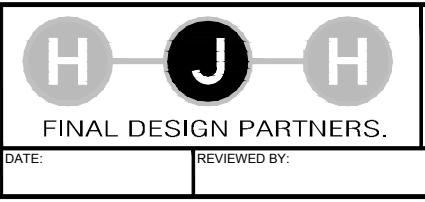
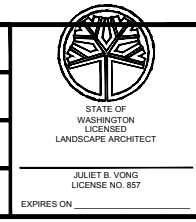

SUBMITTED BY: / DATE: /
 REVIEWED BY: / DATE: /

SCALE: 1" = 20'
 FILENAME: E320-L85-LPP106
 CONTRACT No.: RTA/LR XXXX-XX
 DATE: 12/06/2013

**EAST LINK EXTENSION
 CONTRACT E320
 SOUTH BELLEVUE**

LANDSCAPE
 PLANTING PLAN
 BELLEVUE WAY

DRAWING No.: **L85-LPP106**
 LOCATION ID: **E12**
 SHEET No.: REV: **0**

XREF LIST:
 XE320-L85-CAP100
 XE320-L85-CMP100
 XE320-L85-KAP100
 XE320-L85-SPP100
 XE320-L85-SWP100
 XE320-L85-UCP100
 XE320-GB-TB220-04
 XE320-L85-CRP100
 XE320-L85-FPP100
 XE320-L85-JEP100
 XE320-L85-RP2000
 XE320-L85-RFP100
 XE320-L85-SWP100
 XE320-L85-TSP100
 XE320-L85-SWP100

SEE DWG L85-LPP106

SEE DWG L85-LPP108

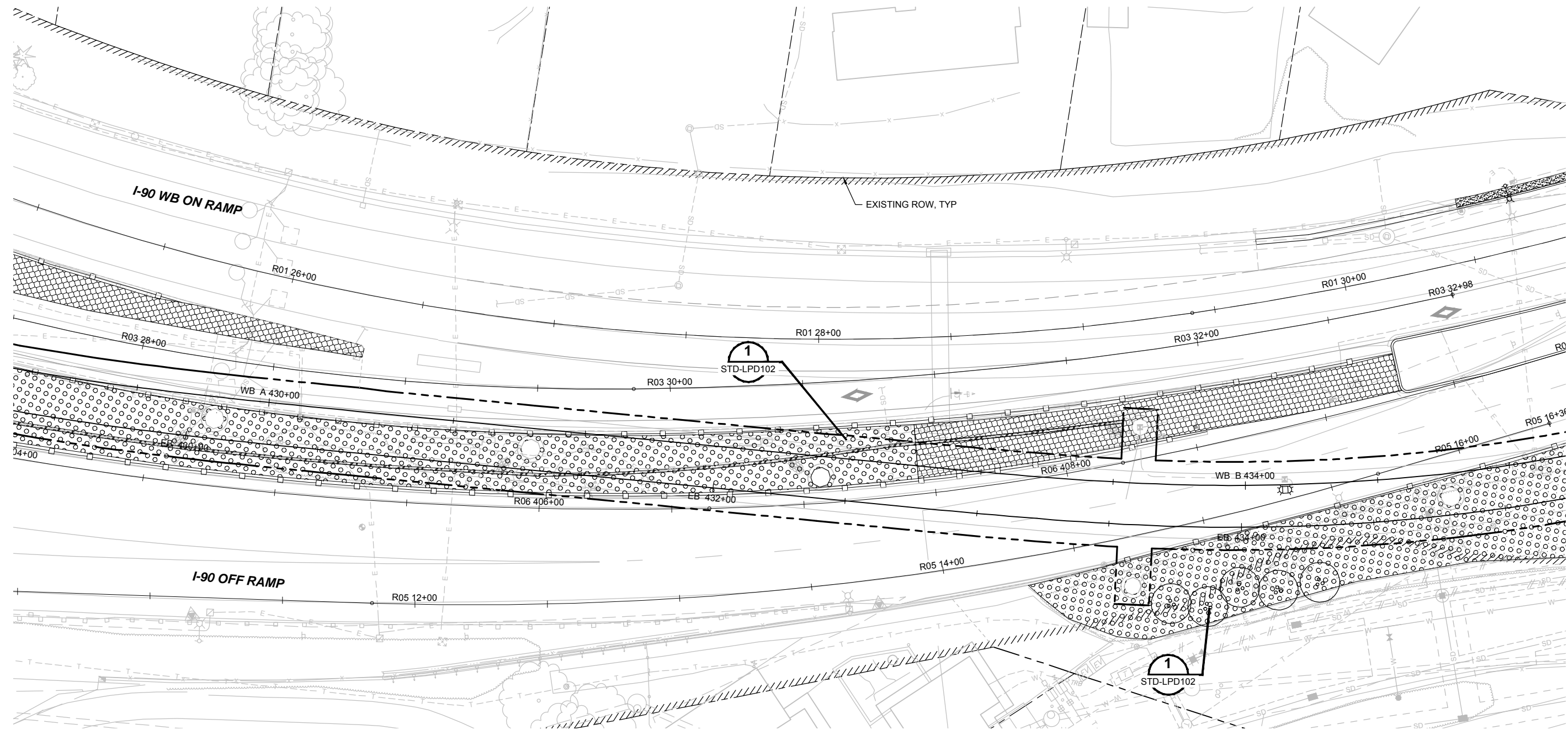

NOTES:

- SEE DWG L85-LPS100 FOR CORRIDOR PLANT SCHEDULE.

ORIGINATED BY: / DATE: /
 CHECKED BY: / DATE: /
 CORRECTED BY: / DATE: /
 VERIFIED BY: / DATE: /
 11/07/13 | 3:21 PM | CALDWELL
 BACK-CHECKED BY: / DATE: /
 C:\USERS\PUBLIC\DOCUMENTS\CALDWELL\HITTPS\SHAREPOINT_SOUNDTRANSIT\ORG\443\SITES\CAD\EL\BEL\RED\E320\L85-LPP107.DWG

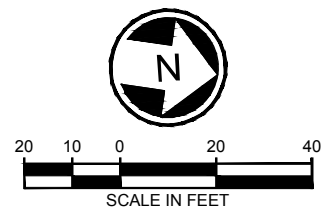

60% SUBMITTAL					
No.	DATE	DSN	CHK	APP	REVISION

DESIGNED BY: J. VONG
DRAWN BY: M. OVIIR
CHECKED BY: D. KOONTZ
APPROVED BY: J. SCHESSLER

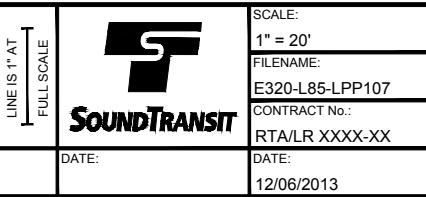
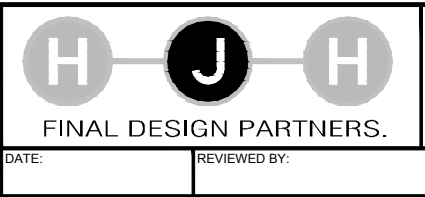
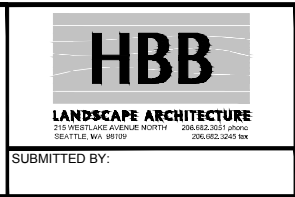
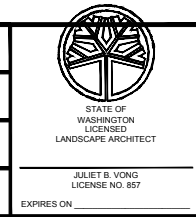

SCALE: 1" = 20'	EAST LINK EXTENSION CONTRACT E320 SOUTH BELLEVUE LANDSCAPE PLANTING PLAN BELLEVUE WAY
FILENAME: E320-L85-LPP107	
CONTRACT No.: RTA/LR XXXX-XX	
DATE: 12/06/2013	

DRAWING No.: L85-LPP107
LOCATION ID: E12
SHEET No.: REV: 0

XREF LIST:
 XE320-L85-CAP100
 XE320-L85-CMP100
 XE320-L85-KAP100
 XE320-L85-SFP100
 XE320-L85-SVP100
 XE320-L85-LCP100
 XE320-L85-TB2204
 XE320-L85-LP100
 XE320-L85-CRP100
 XE320-L85-JEP100
 XE320-L85-RP100
 XE320-L85-RFP100
 XE320-L85-SVP100
 XE320-L85-TSP100

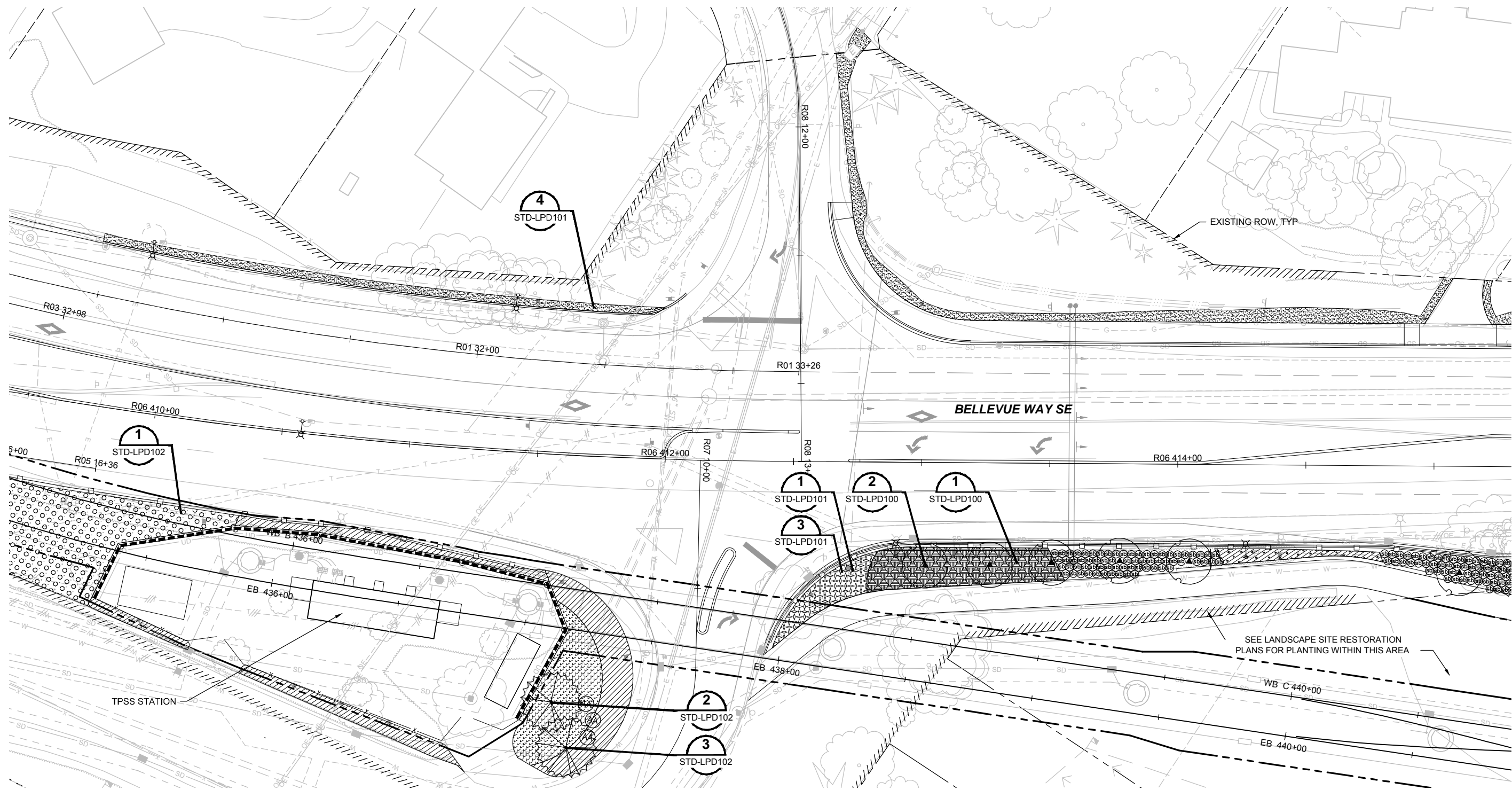

SEE DWG L85-LPP107

SEE DWG L85-LPP109

NOTES:

- 1. SEE DWG L85-LPS100 FOR CORRIDOR PLANT SCHEDULE.
- 2. SEE DRAWINGS L85-LMP108 THRU L85-LMP147 FOR SITE RESTORATION PLANS.

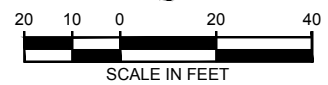

ORIGINATED BY: / DATE: /
 CHECKED BY: / DATE: /
 BACK-CHECKED BY: / DATE: /
 11/07/13 | 3:22 PM | CALDWELL
 C:\USERS\PUBLIC\DOCUMENTS\CALDWELL\HJ\TPSS\SHAREPOINT\SOUNDTRANSIT\ORG\443\SITES\CALDWELL\BELLEVUE\E320-L85-LPP108.DWG

60% SUBMITTAL

DESIGNED BY:
J. YONG
 DRAWN BY:
M. OVIIR
 CHECKED BY:
D. KOONTS
 APPROVED BY:
J. SCHESSLER



HBB
 LANDSCAPE ARCHITECTURE
 715 WEST LANE AVENUE NORTH
 SEATTLE, WA 98107
 206.682.3333 PHONE
 206.682.3245 FAX

H J H
 FINAL DESIGN PARTNERS.

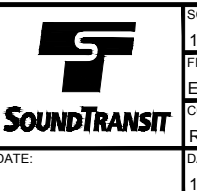

SCALE:
1" = 20'
 FILENAME:
E320-L85-LPP108
 CONTRACT No.:
RTA/LR XXXX-XX
 DATE:
12/06/2013

**EAST LINK EXTENSION
 CONTRACT E320
 SOUTH BELLEVUE**
 LANDSCAPE
 PLANTING PLAN
 BELLEVUE WAY AND PARK MITIGATION

DRAWING No.:
L85-LPP108
 LOCATION ID:
E12
 SHEET No.: REV:
0

No.	DATE	DSN	CHK	APP	REVISION

XREF LIST:
 XE320-L85-CAP100
 XE320-L85-CMP100
 XE320-L85-KAP100
 XE320-L85-SFP100
 XE320-L85-SVP100
 XE320-L85-UCP100
 XE320-L85-RP100
 XE320-L85-SFP100
 XE320-L85-SVP100
 XE320-L85-SFP100
 XE320-L85-SVP100
 XE320-L85-CRP100
 XE320-L85-LPP100
 XE320-E09-AFP100
 XE320-L85-REP100
 XE320-P09-CLP100
 XE320-P09-CRP100

11/07/13 | 3:22 PM | CALDWELL
 C:\USERS\PUBLIC\DOCUMENTS\CALDWELL\HITTPS\SHAREPOINT\SOUNDTRANSIT\ORG\443\SITES\CAD\EL\BEL\RED\E320\DRAWINGS\E320-L85-LPP109.DWG

ORIGINATED BY: / DATE: /
 CHECKED BY: / DATE: /
 BACK-CHECKED BY: / DATE: /
 CORRECTED BY: / DATE: /
 VERIFIED BY: / DATE: /

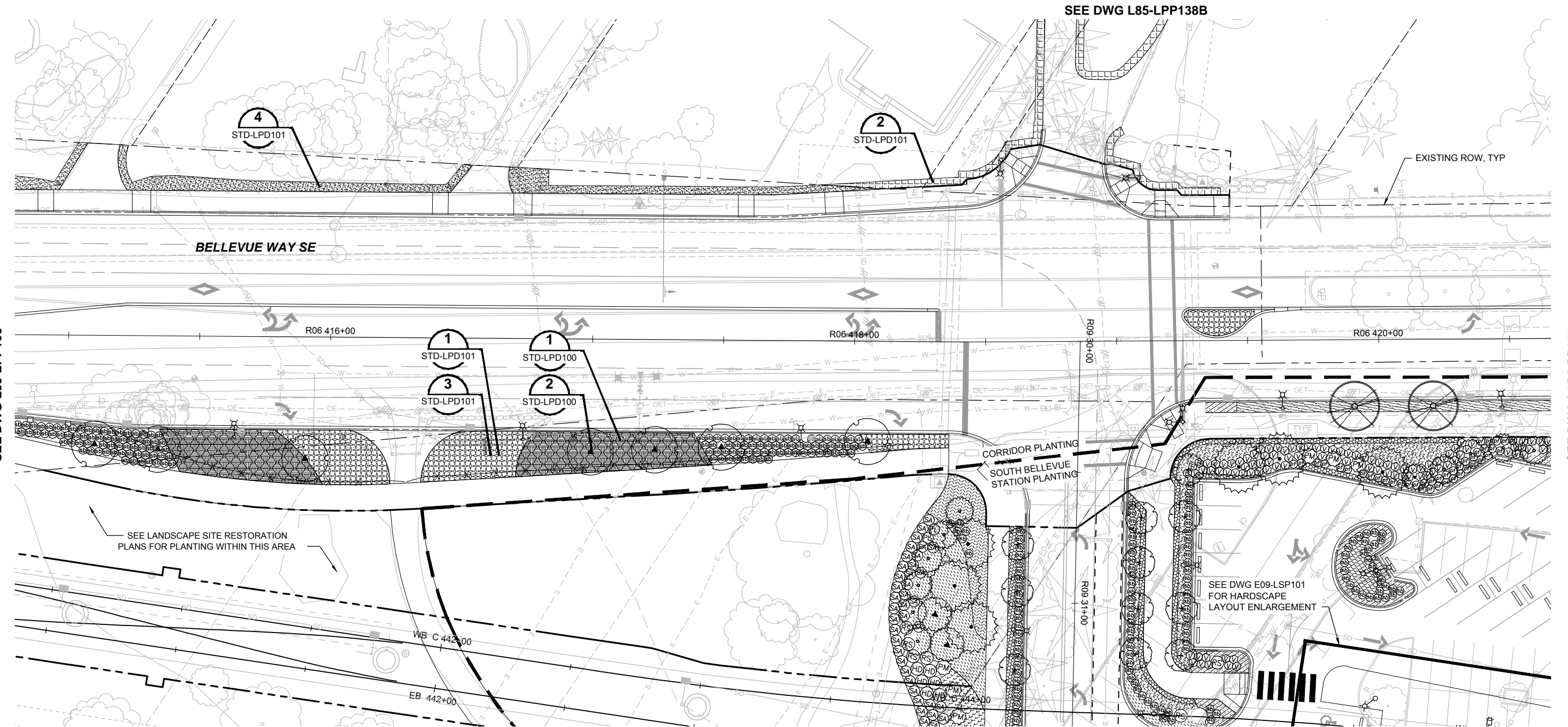

SEE DWG L85-LPP108

SEE DWG L85-LPP110

SEE DWG L85-LPP231

- NOTES:**
- SEE DWG L85-LPS100 FOR CORRIDOR PLANT SCHEDULE.
 - SEE DRAWINGS L85-LMP108 THRU L85-LMP147 FOR SITE RESTORATION PLANS.
 - SEE DWG L85-LPS200 FOR STATION AREA PLANT SCHEDULE.

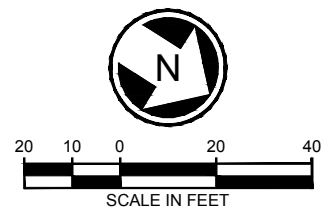

60% SUBMITTAL

DESIGNED BY:
J. YONG
 DRAWN BY:
M. OVIIR
 CHECKED BY:
D. KOONTS
 APPROVED BY:
J. SCHEITLER



SCALE:
1" = 20'
 FILENAME:
E320-L85-LPP109
 CONTRACT No.:
RTA/LR XXXX-XX
 DATE:
12/06/2013

**EAST LINK EXTENSION
 CONTRACT E320
 SOUTH BELLEVUE**
 LANDSCAPE
 PLANTING PLAN
 BELLEVUE WAY AND PARK MITIGATION

DRAWING No.:
L85-LPP109
 LOCATION ID:
E12
 SHEET No.: REV:
0

No.	DATE	DSN	CHK	APP	REVISION

XREF LIST:
 XE320-L85-CAP100
 XE320-L85-CMP100
 XE320-L85-KAP100
 XE320-L85-SFP100
 XE320-L85-SVP100
 XE320-L85-UCP100
 XE320-L85-TBZ204
 XE320-L85-TBZ205
 XE320-L85-TBZ206
 XE320-L85-TBZ207
 XE320-L85-TBZ208
 XE320-L85-TBZ209
 XE320-L85-TBZ210
 XE320-L85-TBZ211
 XE320-L85-TBZ212
 XE320-L85-TBZ213
 XE320-L85-TBZ214
 XE320-L85-TBZ215
 XE320-L85-TBZ216
 XE320-L85-TBZ217
 XE320-L85-TBZ218
 XE320-L85-TBZ219
 XE320-L85-TBZ220
 XE320-L85-TBZ221
 XE320-L85-TBZ222
 XE320-L85-TBZ223
 XE320-L85-TBZ224
 XE320-L85-TBZ225
 XE320-L85-TBZ226
 XE320-L85-TBZ227
 XE320-L85-TBZ228
 XE320-L85-TBZ229
 XE320-L85-TBZ230
 XE320-L85-TBZ231
 XE320-L85-TBZ232
 XE320-L85-TBZ233
 XE320-L85-TBZ234
 XE320-L85-TBZ235
 XE320-L85-TBZ236
 XE320-L85-TBZ237
 XE320-L85-TBZ238
 XE320-L85-TBZ239
 XE320-L85-TBZ240
 XE320-L85-TBZ241
 XE320-L85-TBZ242
 XE320-L85-TBZ243
 XE320-L85-TBZ244
 XE320-L85-TBZ245
 XE320-L85-TBZ246
 XE320-L85-TBZ247
 XE320-L85-TBZ248
 XE320-L85-TBZ249
 XE320-L85-TBZ250
 XE320-L85-TBZ251
 XE320-L85-TBZ252
 XE320-L85-TBZ253
 XE320-L85-TBZ254
 XE320-L85-TBZ255
 XE320-L85-TBZ256
 XE320-L85-TBZ257
 XE320-L85-TBZ258
 XE320-L85-TBZ259
 XE320-L85-TBZ260
 XE320-L85-TBZ261
 XE320-L85-TBZ262
 XE320-L85-TBZ263
 XE320-L85-TBZ264
 XE320-L85-TBZ265
 XE320-L85-TBZ266
 XE320-L85-TBZ267
 XE320-L85-TBZ268
 XE320-L85-TBZ269
 XE320-L85-TBZ270
 XE320-L85-TBZ271
 XE320-L85-TBZ272
 XE320-L85-TBZ273
 XE320-L85-TBZ274
 XE320-L85-TBZ275
 XE320-L85-TBZ276
 XE320-L85-TBZ277
 XE320-L85-TBZ278
 XE320-L85-TBZ279
 XE320-L85-TBZ280
 XE320-L85-TBZ281
 XE320-L85-TBZ282
 XE320-L85-TBZ283
 XE320-L85-TBZ284
 XE320-L85-TBZ285
 XE320-L85-TBZ286
 XE320-L85-TBZ287
 XE320-L85-TBZ288
 XE320-L85-TBZ289
 XE320-L85-TBZ290
 XE320-L85-TBZ291
 XE320-L85-TBZ292
 XE320-L85-TBZ293
 XE320-L85-TBZ294
 XE320-L85-TBZ295
 XE320-L85-TBZ296
 XE320-L85-TBZ297
 XE320-L85-TBZ298
 XE320-L85-TBZ299
 XE320-L85-TBZ300
 XE320-L85-TBZ301
 XE320-L85-TBZ302
 XE320-L85-TBZ303
 XE320-L85-TBZ304
 XE320-L85-TBZ305
 XE320-L85-TBZ306
 XE320-L85-TBZ307
 XE320-L85-TBZ308
 XE320-L85-TBZ309
 XE320-L85-TBZ310
 XE320-L85-TBZ311
 XE320-L85-TBZ312
 XE320-L85-TBZ313
 XE320-L85-TBZ314
 XE320-L85-TBZ315
 XE320-L85-TBZ316
 XE320-L85-TBZ317
 XE320-L85-TBZ318
 XE320-L85-TBZ319
 XE320-L85-TBZ320
 XE320-L85-TBZ321
 XE320-L85-TBZ322
 XE320-L85-TBZ323
 XE320-L85-TBZ324
 XE320-L85-TBZ325
 XE320-L85-TBZ326
 XE320-L85-TBZ327
 XE320-L85-TBZ328
 XE320-L85-TBZ329
 XE320-L85-TBZ330
 XE320-L85-TBZ331
 XE320-L85-TBZ332
 XE320-L85-TBZ333
 XE320-L85-TBZ334
 XE320-L85-TBZ335
 XE320-L85-TBZ336
 XE320-L85-TBZ337
 XE320-L85-TBZ338
 XE320-L85-TBZ339
 XE320-L85-TBZ340
 XE320-L85-TBZ341
 XE320-L85-TBZ342
 XE320-L85-TBZ343
 XE320-L85-TBZ344
 XE320-L85-TBZ345
 XE320-L85-TBZ346
 XE320-L85-TBZ347
 XE320-L85-TBZ348
 XE320-L85-TBZ349
 XE320-L85-TBZ350
 XE320-L85-TBZ351
 XE320-L85-TBZ352
 XE320-L85-TBZ353
 XE320-L85-TBZ354
 XE320-L85-TBZ355
 XE320-L85-TBZ356
 XE320-L85-TBZ357
 XE320-L85-TBZ358
 XE320-L85-TBZ359
 XE320-L85-TBZ360
 XE320-L85-TBZ361
 XE320-L85-TBZ362
 XE320-L85-TBZ363
 XE320-L85-TBZ364
 XE320-L85-TBZ365
 XE320-L85-TBZ366
 XE320-L85-TBZ367
 XE320-L85-TBZ368
 XE320-L85-TBZ369
 XE320-L85-TBZ370
 XE320-L85-TBZ371
 XE320-L85-TBZ372
 XE320-L85-TBZ373
 XE320-L85-TBZ374
 XE320-L85-TBZ375
 XE320-L85-TBZ376
 XE320-L85-TBZ377
 XE320-L85-TBZ378
 XE320-L85-TBZ379
 XE320-L85-TBZ380
 XE320-L85-TBZ381
 XE320-L85-TBZ382
 XE320-L85-TBZ383
 XE320-L85-TBZ384
 XE320-L85-TBZ385
 XE320-L85-TBZ386
 XE320-L85-TBZ387
 XE320-L85-TBZ388
 XE320-L85-TBZ389
 XE320-L85-TBZ390
 XE320-L85-TBZ391
 XE320-L85-TBZ392
 XE320-L85-TBZ393
 XE320-L85-TBZ394
 XE320-L85-TBZ395
 XE320-L85-TBZ396
 XE320-L85-TBZ397
 XE320-L85-TBZ398
 XE320-L85-TBZ399
 XE320-L85-TBZ400

11/07/13 | 3:23 PM | CALDWELL
 C:\USERS\PUBLIC\DOCUMENTS\CALDWELL\HITTPS\SHAREPOINT\ SOUNDTRANSIT\ORG\443\SITES\CAD\ELBEL\RED\E320\L85-LPP110.DWG
 CORRECTED BY: / DATE: /
 VERIFIED BY: / DATE: /
 CHECKED BY: / DATE: /
 ORIGINAL BY: / DATE: /

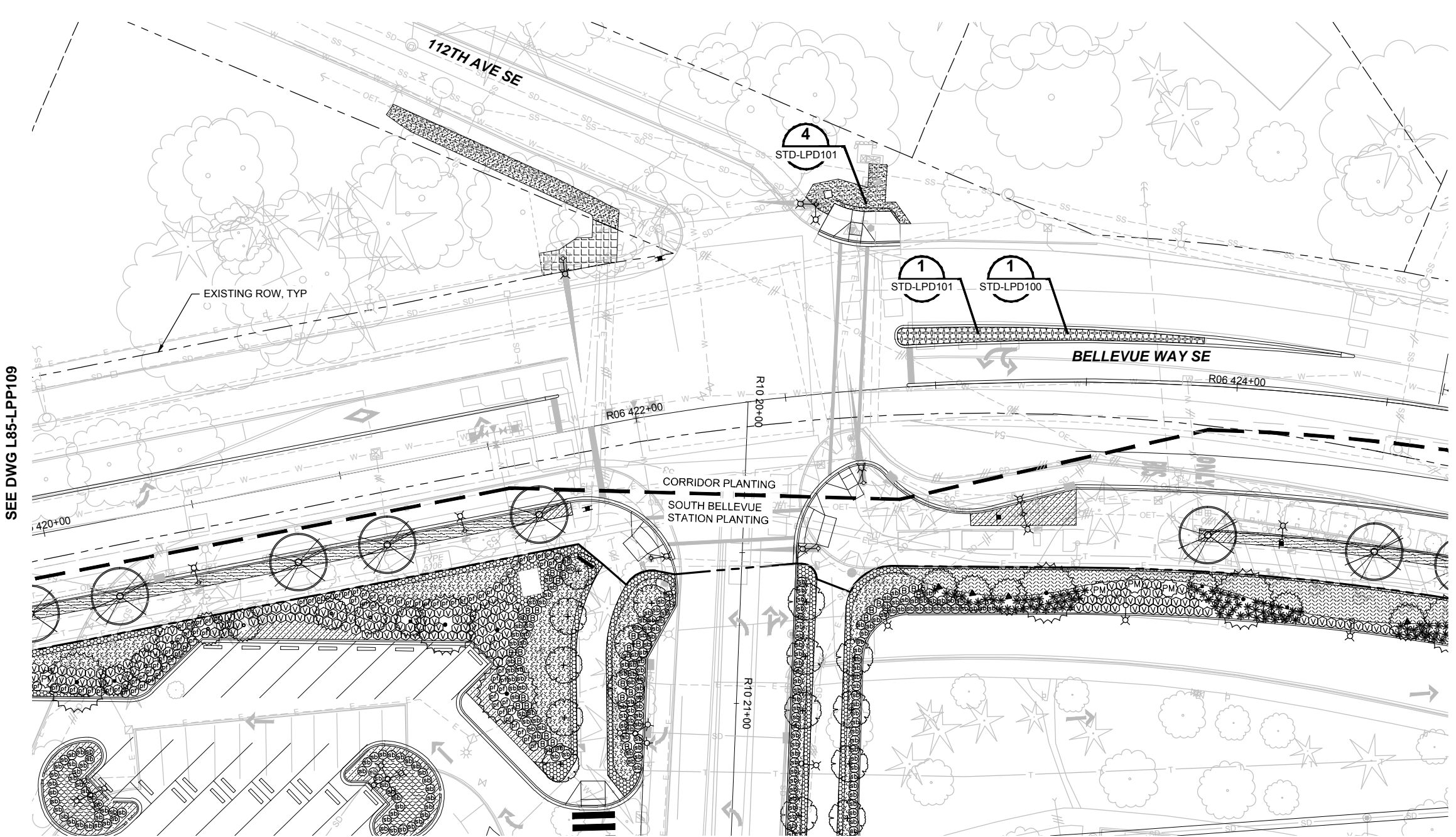

SEE DWG L85-LPP109

SEE DWG L85-LPP111

SEE DWG L85-LPP229

SEE DWG L85-LPP230

- NOTES:**
- SEE DWG L85-LPS100 FOR CORRIDOR PLANT SCHEDULE.
 - SEE DWG L85-LPS200 FOR STATION AREA PLANT SCHEDULE.



60% SUBMITTAL

DESIGNED BY:
J. YONG
 DRAWN BY:
M. OVIIR
 CHECKED BY:
D. KOONTS
 APPROVED BY:
J. SCETTTLER



SCALE:
1" = 20'
 FILENAME:
E320-L85-LPP110
 CONTRACT No.:
RTA/LR XXXX-XX
 DATE:
12/06/2013

**EAST LINK EXTENSION
 CONTRACT E320
 SOUTH BELLEVUE**
 LANDSCAPE
 PLANTING PLAN
 BELLEVUE WAY

DRAWING No.:
L85-LPP110
 LOCATION ID:
E12
 SHEET No.:
REV:
0

XREF LIST:
 XE320-L85-CAP100
 XE320-L85-CMP100
 XE320-L85-KAP100
 XE320-L85-SFP100
 XE320-L85-SWP100
 XE320-L85-LCP100
 XE320-L85-RPP100
 XE320-L85-TS200A
 XE320-L85-TS200B
 XE320-L85-APP200
 XE320-L85-SSP100
 XE320-L85-SFP100
 XE320-L85-SWP100
 XE320-L85-LCP100
 XE320-L85-CMP100
 XE320-L85-KAP100
 XE320-L85-SFP100
 XE320-L85-SWP100
 XE320-L85-LCP100
 XE320-L85-CMP100
 XE320-L85-KAP100
 XE320-L85-SFP100
 XE320-L85-SWP100
 XE320-L85-LCP100
 XE320-L85-CMP100
 XE320-L85-KAP100
 XE320-L85-SFP100
 XE320-L85-SWP100
 XE320-L85-LCP100

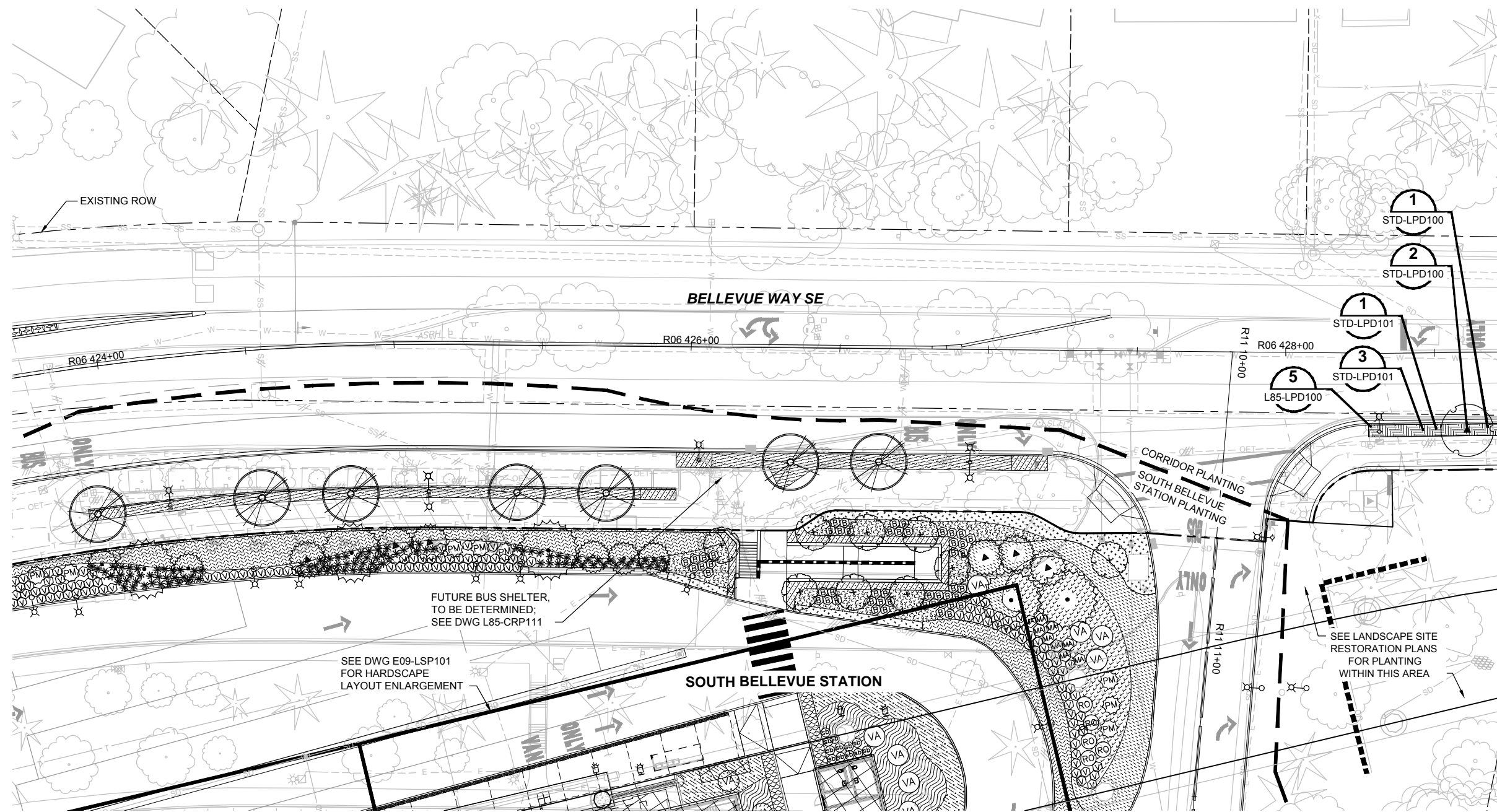

SEE DWG L85-LPP110

SEE DWG L85-LPP112

SEE DWG L85-LPP230

- NOTES:**
1. SEE DWG L85-LPS100 AND L85-LPS100B FOR CORRIDOR PLANT SCHEDULE.
 2. SEE DRAWINGS L85-LMP108 THRU L85-LMP147 FOR SITE RESTORATION PLANS.
 3. SEE DWG L85-LPS200 FOR STATION AREA PLANT SCHEDULE.

11/07/13 3:24 PM | CALDWELL
 C:\USERS\PUBLIC\DOCUMENTS\CALDWELL\HNTPS\SHAREPOINT\ SOUNDTRANSIT\ORG\443\SITES\CAD\ELBEL\RED\E320\DRAWINGS\E320-L85-LPP111.DWG
 CORRECTED BY: / DATE: /
 VERIFIED BY: / DATE: /
 CHECKED BY: / DATE: /
 ORIGINAL BY: / DATE: /



60% SUBMITTAL

DESIGNED BY:
J. YONG
 DRAWN BY:
M. OVIIR
 CHECKED BY:
D. KOONTS
 APPROVED BY:
J. SCHEITLER



SCALE:
 1" = 20'
 FILENAME:
E320-L85-LPP111
 CONTRACT No.:
RTA/LR XXXX-XX
 DATE:
12/06/2013

**EAST LINK EXTENSION
 CONTRACT E320
 SOUTH BELLEVUE**
 LANDSCAPE
 PLANTING PLAN
 BELLEVUE WAY AND PARK MITIGATION

DRAWING No.:
L85-LPP111
 LOCATION ID:
E12
 SHEET No.:
0
 REV:
0

No.	DATE	DSN	CHK	APP	REVISION

XREF LIST:
 XE320-L85-CAP100
 XE320-L85-CMP100
 XE320-L85-KAP100
 XE320-L85-SFP100
 XE320-L85-SWP100
 XE320-L85-UCP100
 XE320-L85-RZV000
 XE320-L85-SFP100
 XE320-L85-SWP100
 XE320-L85-TS2204
 XE320-L85-LPD100
 XE320-L85-CMP100
 XE320-L85-CLP100
 XE320-L85-TSP100
 XE320-L85-LMP100

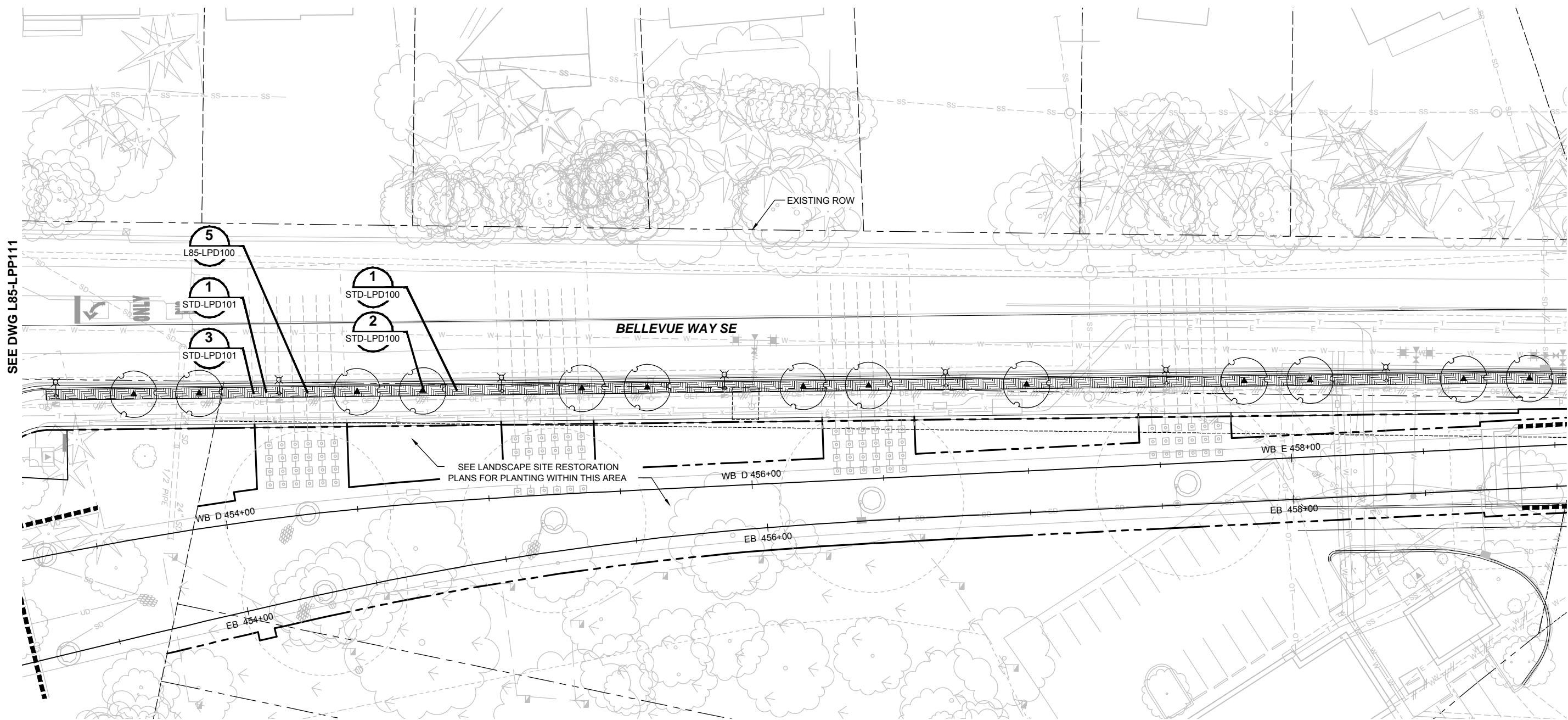

SEE DWG L85-LPP111

SEE DWG L85-LPP113

- NOTES:**
- SEE DWG L85-LPS100 AND DWG L85-LPS100B FOR CORRIDOR PLANT SCHEDULE.
 - SEE DRAWINGS L85-LMP108 THRU L85-LMP147 FOR SITE RESTORATION PLANS.

ORIGINATED BY: / DATE: /
 CHECKED BY: / DATE: /
 BACK-CHECKED BY: / DATE: /
 11/07/13 | 3:24 PM | CALDWELL
 C:\USERS\PUBLIC\DOCUMENTS\CALDWELL\HTTTPS\SHAREPOINT\SOUNDTRANSIT\ORG\443\SITES\CAD\EL\RED\E320\DRAWINGS\E320-L85-LPP112.DWG

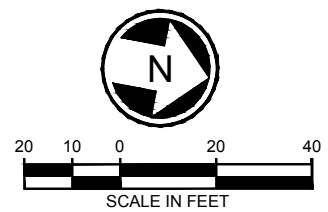

60% SUBMITTAL					
No.	DATE	DSN	CHK	APP	REVISION

DESIGNED BY:
J. VONG
 DRAWN BY:
M. OVIIR
 CHECKED BY:
D. KOONTS
 APPROVED BY:
J. SCHESSLER

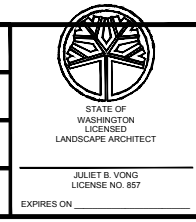

HBB
 LANDSCAPE ARCHITECTURE
 715 WEST LANE AVENUE NORTH
 SEATTLE, WA 98107
 206.622.2037 PHONE
 206.682.3245 FAX

H J H
 FINAL DESIGN PARTNERS.
 SUBMITTED BY: / DATE: /
 REVIEWED BY: / DATE: /

SOUNDTRANSIT
 SCALE:
1" = 20'
 FILENAME:
E320-L85-LPP112
 CONTRACT No.:
RTA/LR XXXX-XX
 DATE:
12/06/2013

**EAST LINK EXTENSION
 CONTRACT E320
 SOUTH BELLEVUE**
 LANDSCAPE
 PLANTING PLAN
 BELLEVUE WAY AND PARK MITIGATION

DRAWING No.:
L85-LPP112
 LOCATION ID:
E12
 SHEET No.: / REV:
/ 0

XREF LIST:
 XE320-L85-CAP100
 XE320-L85-COP100
 XE320-L85-CMP100
 XE320-L85-KAP100
 XE320-L85-SFP100
 XE320-L85-SVP100
 XE320-L85-UCP100
 XE320-GB-TB2204
 XE320-L85-LPP100
 XE320-L85-CRP100
 XE320-L85-JEP100
 GB-SEA-BY887
 XE320-L85-R2100
 XE320-L85-RFP100
 XE320-L85-LMP100
 XE320-L85-COP100
 XE320-L85-CMP100
 XE320-L85-TSP100
 XE320-L85-SVP100
 XE320-L85-LPP101

SEE DWG L85-LPP112

SEE DWG L85-LPP114



NOTES:

1. SEE DWG L85-LPS100 AND LPS100B FOR CORRIDOR PLANT SCHEDULE.
2. SEE DRAWINGS L85-LMP108 THRU L85-LMP147 FOR SITE RESTORATION PLANS.
3. SEE DWG L85-LPS101 FOR PARK MITIGATION PLANT SCHEDULE.

ORIGINATED BY: / DATE: /
 CHECKED BY: / DATE: /
 BACK-CHECKED BY: / DATE: /
 11/11/13 | 9:41 AM | CALDWELL
 C:\USERS\PUBLIC\DOCUMENTS\CALDWELL\H\TTPS\SHAREPOINT\SOUNDTRANSIT\ORG\443\SITES\CAD\ELBEL\RED\E320\DRAWINGS\E320-L85-LPP113.DWG

CORRECTED BY: / DATE: /
 VERIFIED BY: / DATE: /

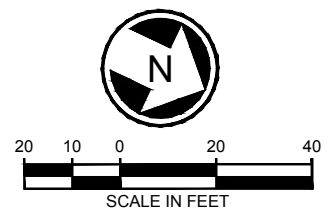

60% SUBMITTAL					DESIGNED BY: J. YONG	 <small>STATE OF WASHINGTON LICENSED LANDSCAPE ARCHITECT</small>	 <small>LANDSCAPE ARCHITECTURE 715 WEST LANE AVENUE NORTH SEATTLE, WA 98107 206.622.3333 JUNE 206.692.3245 BK</small>	 FINAL DESIGN PARTNERS.	 SOUNDTRANSIT	SCALE: 1" = 20'	EAST LINK EXTENSION CONTRACT E320 SOUTH BELLEVUE LANDSCAPE PLANTING PLAN BELLEVUE WAY AND PARK MITIGATION	DRAWING No.: L85-LPP113
					DRAWN BY: M. OVIIR					FILENAME: E320-L85-LPP113		LOCATION ID: E12
					CHECKED BY: D. KOONTS	CONTRACT No.: RTA/LR XXXX-XX	SHEET No.: REV: 0					
					APPROVED BY: J. SCHEITLER	DATE: 12/06/2013	EXPIRES ON:					M-117

XREF LIST:
 XE320-L85-CAP100
 XE320-L85-CMP100
 XE320-L85-KAP100
 XE320-L85-SFP100
 XE320-L85-SVP100
 XE320-L85-UCP100
 XE320-L85-TB22004
 XE320-L85-LPP100
 XE320-L85-RFP100
 XE320-L85-JEP100
 XE320-L85-IBY887
 XE320-L85-FR100
 XE320-L85-RFP100
 XEL-0619g
 XEL-0219g
 XEL-0219a
 XEL-0219b
 XEL-0619a
 XE320-L85-LMP100
 XE320-L85-LPP101
 XE320-L85-LSP101
 XE320-L85-CLP100
 XE320-L85-TSP100
 XE320-L85-CDP100
 XE320-L85-SEP100

CORRECTED BY: / DATE: /
 VERIFIED BY: / DATE: /

ORIGINATED BY: / DATE: /
 CHECKED BY: / DATE: /
 BACK-CHECKED BY: / DATE: /
 11/11/13 | 9:00 AM | CALDWELL
 C:\USERS\PUBLIC\DOCUMENTS\CALDWELL\HITTPS\SHAREPOINT\SOUNDTRANSIT\ORG\443\SITES\CAD\EL\BEL\RED\E320\DRAWINGS\E320-L85-LPP114.DWG

SEE DWG L85-LPP113

SEE DWG L85-LPP115

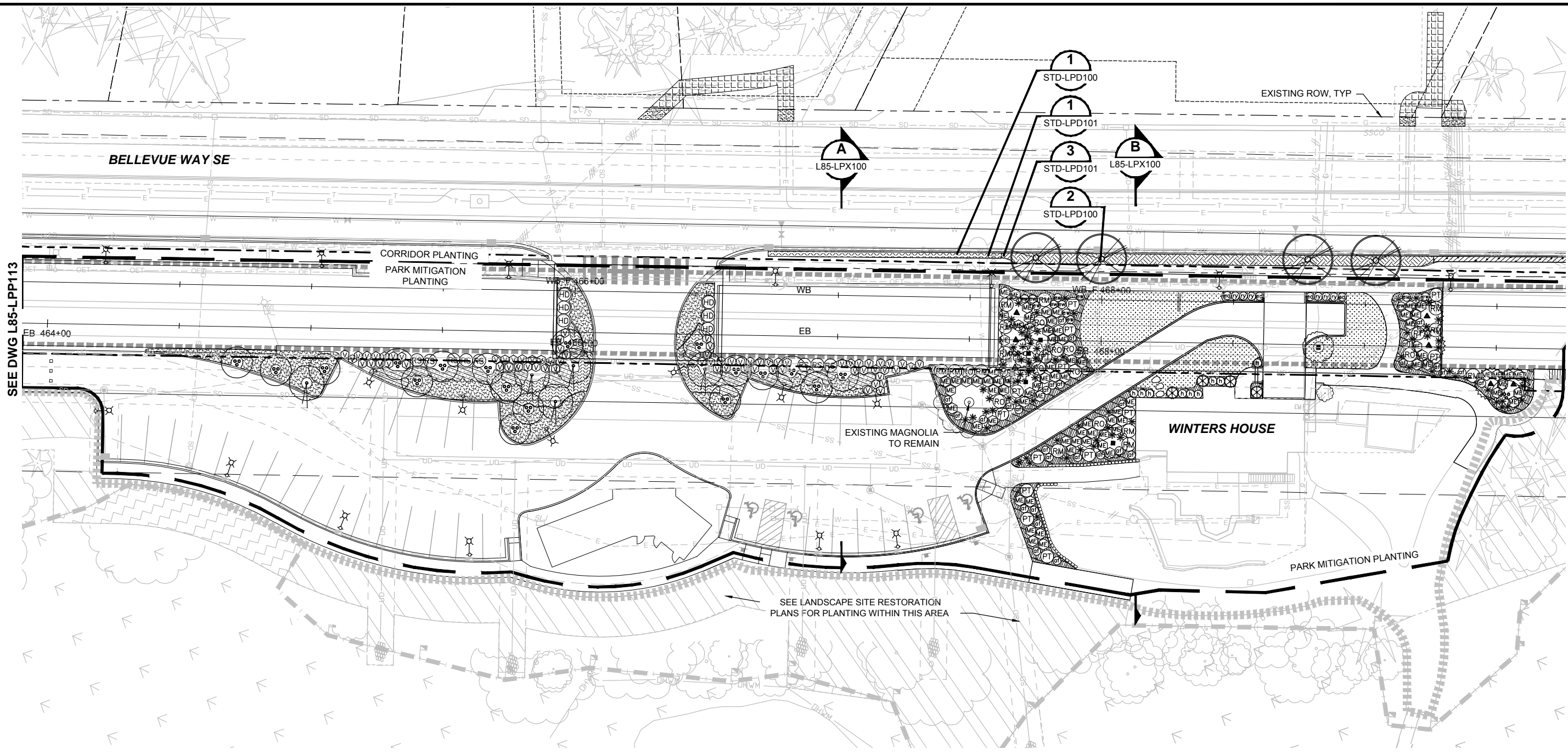

NOTES:

1. SEE DWG L85-LPS100 AND LPS100B FOR CORRIDOR PLANT SCHEDULE.
2. SEE DRAWINGS L85-LMP108 THRU L85-LMP147 FOR SITE RESTORATION PLANS.
3. SEE DWG L85-LPS101 FOR PARK MITIGATION PLANT SCHEDULE.
4. SEE DWG L85-LPP400 FOR WINTERS HOUSE PLANTING ENLARGEMENT PLAN.

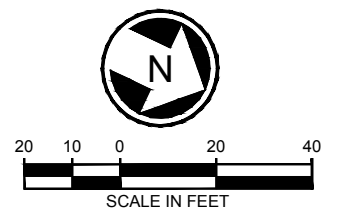

60% SUBMITTAL

DESIGNED BY:
J. VONG
 DRAWN BY:
M. OVIIR
 CHECKED BY:
D. KOONTS
 APPROVED BY:
J. SCHESSLER



SCALE:
1" = 20'
 FILENAME:
E320-L85-LPP114
 CONTRACT No.:
RTA/LR XXXX-XX
 DATE:
12/06/2013

**EAST LINK EXTENSION
 CONTRACT E320
 SOUTH BELLEVUE**
 LANDSCAPE
 PLANTING PLAN
 BELLEVUE WAY AND PARK MITIGATION

DRAWING No.:
L85-LPP114
 LOCATION ID:
E12
 SHEET No.:
REV:
0

SOUND TRANSIT

EAST LINK EXTENSION

EAST MAIN STATION

EAST MAIN STATION NEIGHBORHOOD CONTEXT PLAN

EAST LINK EXTENSION

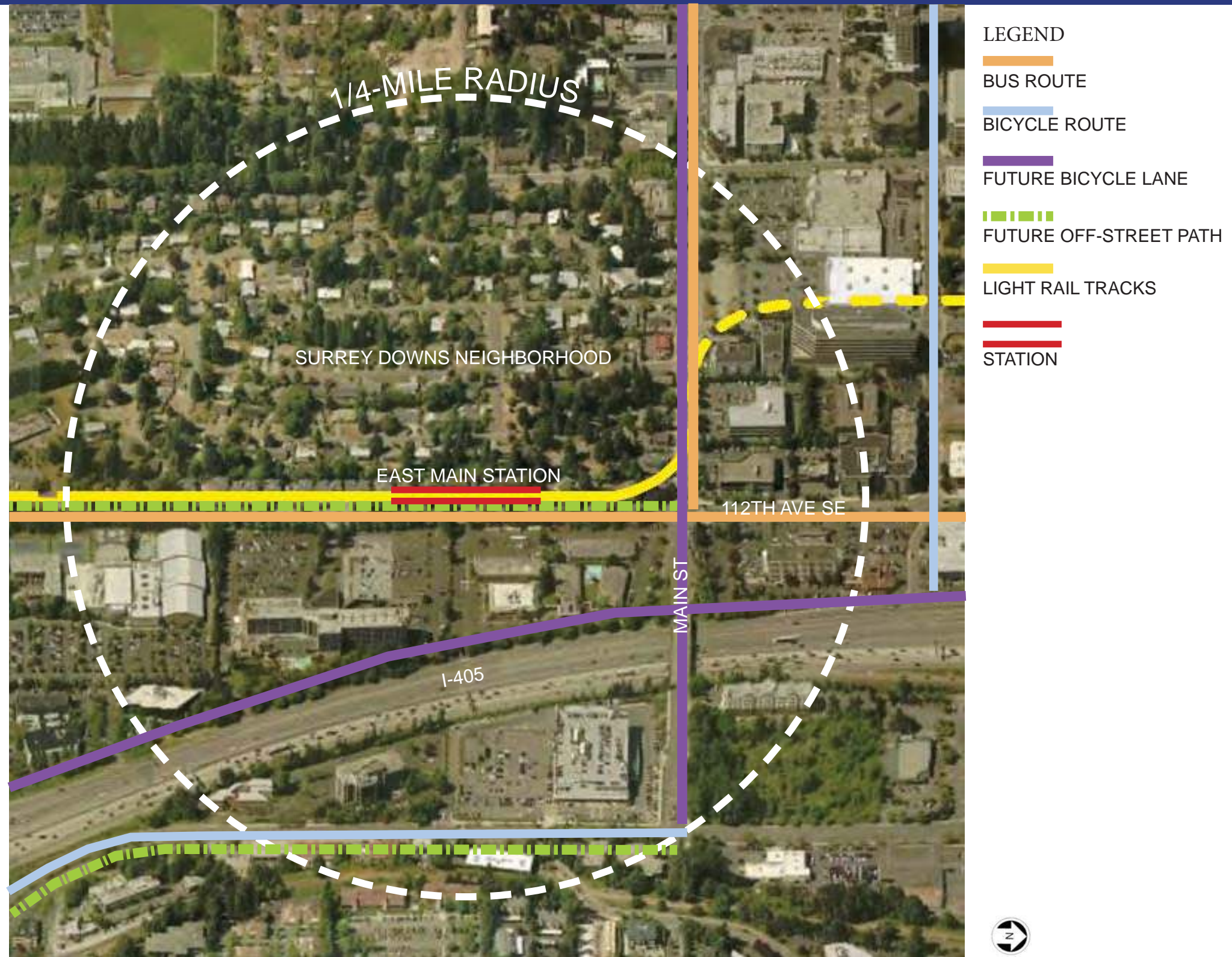

EAST MAIN STATION LANDSCAPING PLAN

EAST LINK EXTENSION



EAST MAIN STATION PLATFORM & ROOF PLANS

EAST LINK EXTENSION

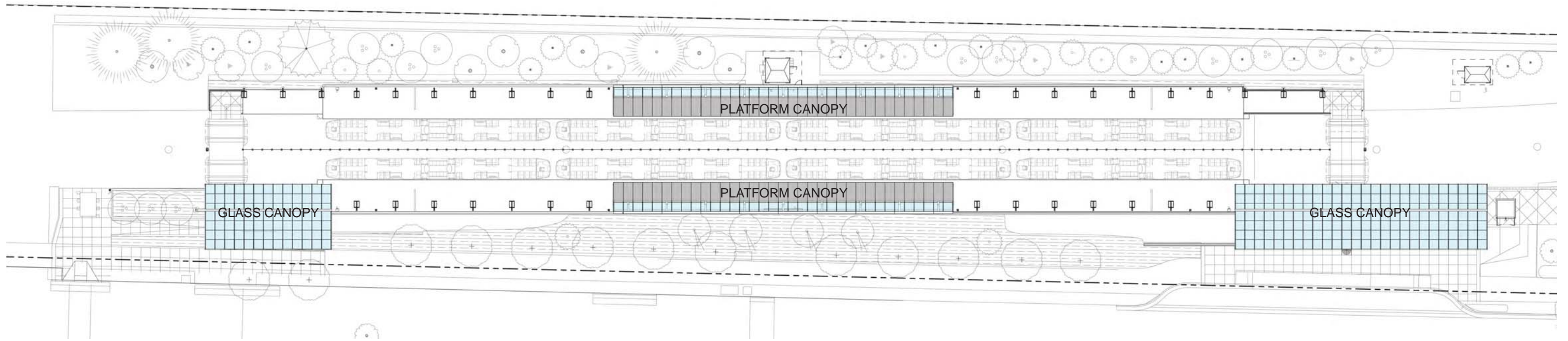

ROOF PLAN

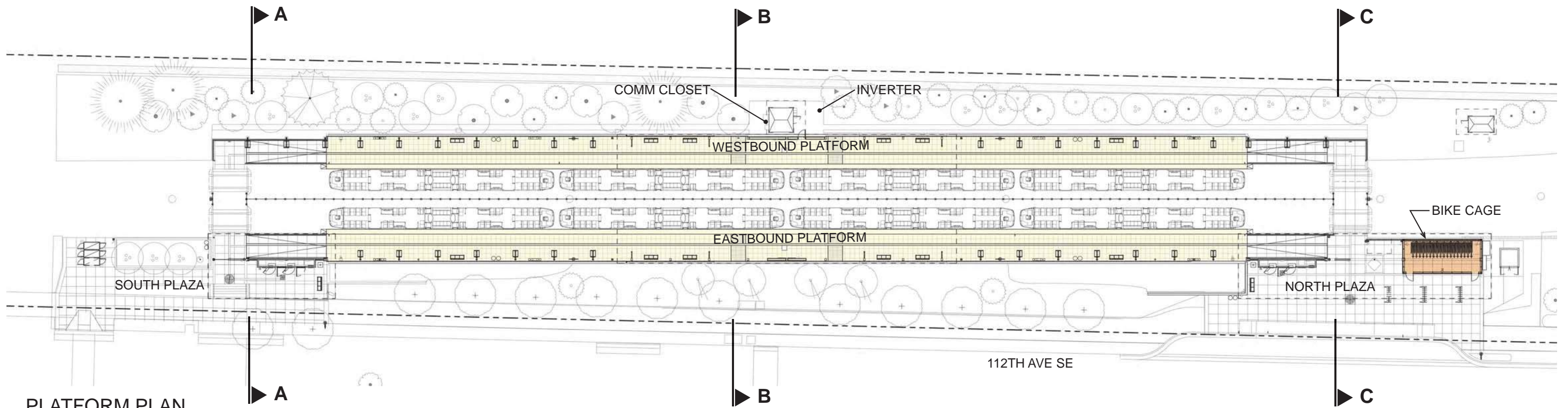

PLATFORM PLAN



EAST MAIN STATION PLATFORM SECTION

EAST LINK EXTENSION

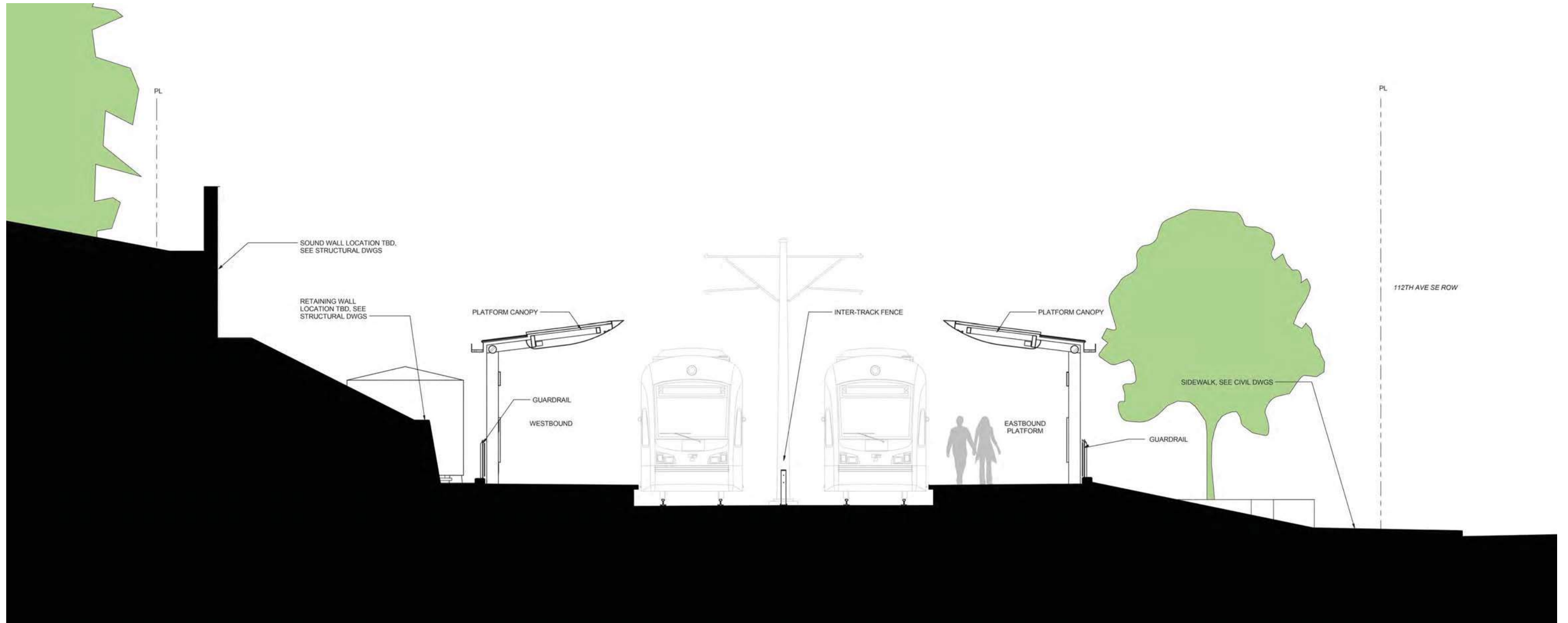

SECTION B-B

EAST MAIN STATION SOUTH PLAZA PLAN EAST LINK EXTENSION

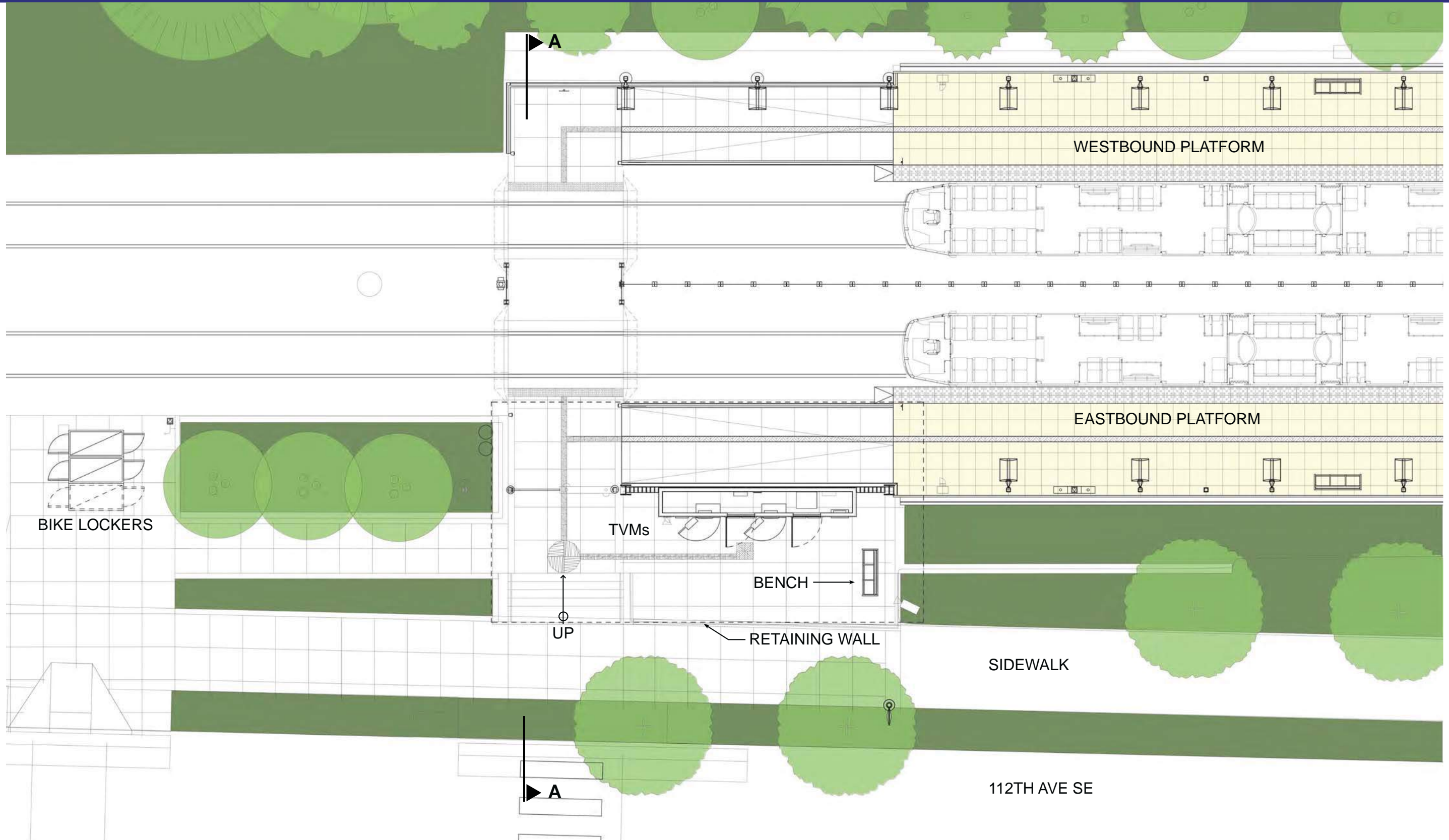

EAST MAIN STATION SOUTH PLAZA SECTION

EAST LINK EXTENSION

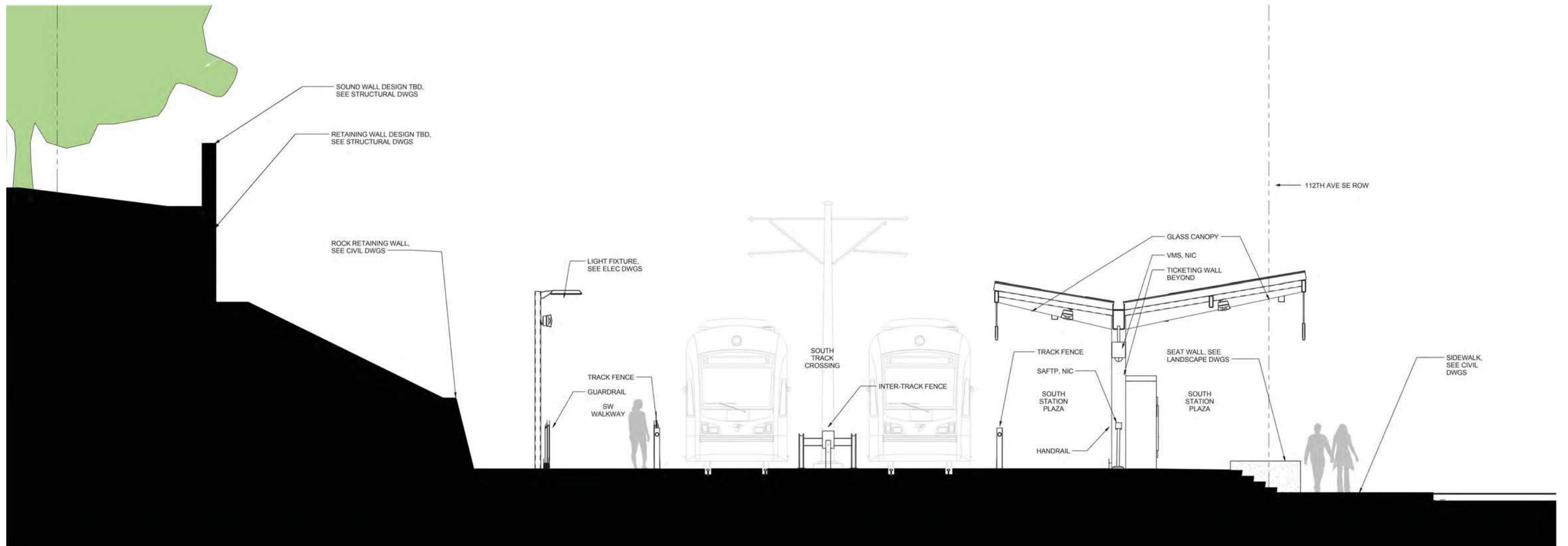

SECTION A-A

EAST MAIN STATION NORTH PLAZA PLAN

EAST LINK EXTENSION

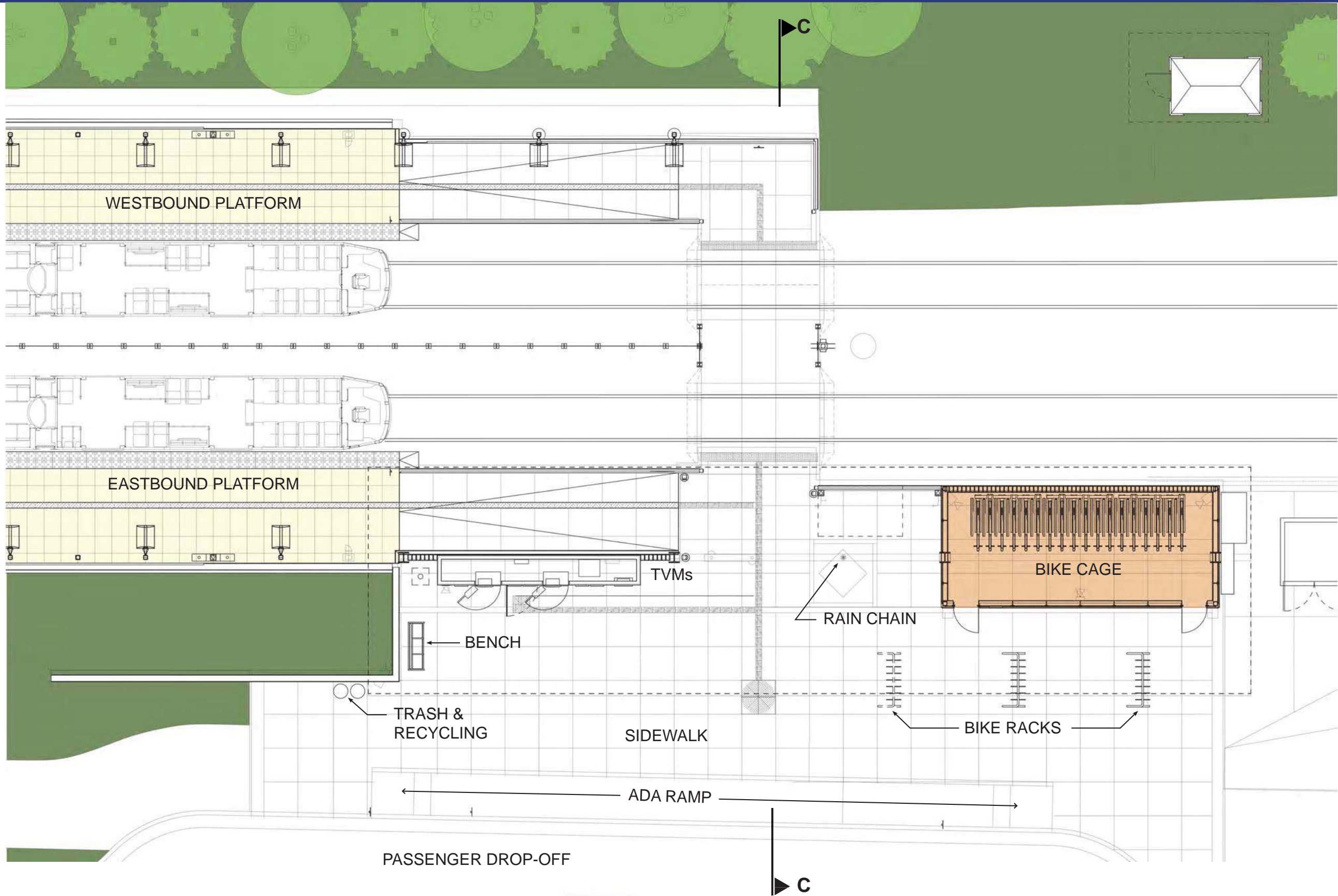

EAST MAIN STATION NORTH PLAZA SECTION

EAST LINK EXTENSION

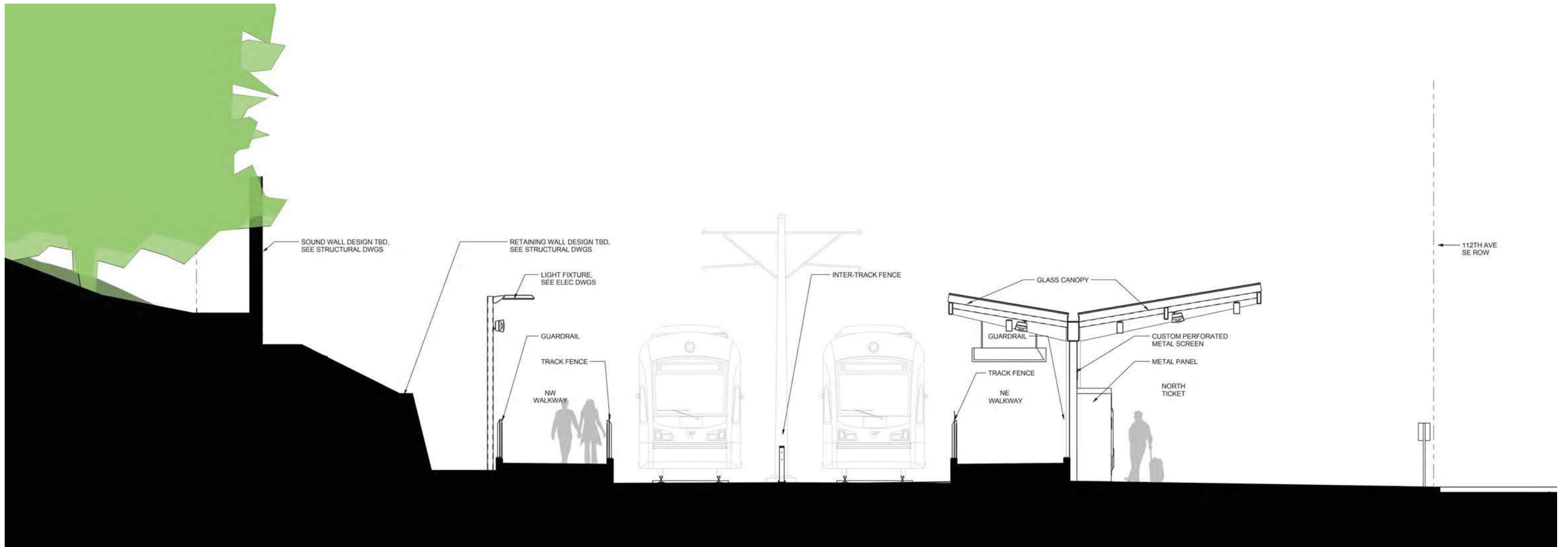

SECTION C-C

EAST MAIN STATION EAST & WEST ELEVATIONS

EAST LINK EXTENSION

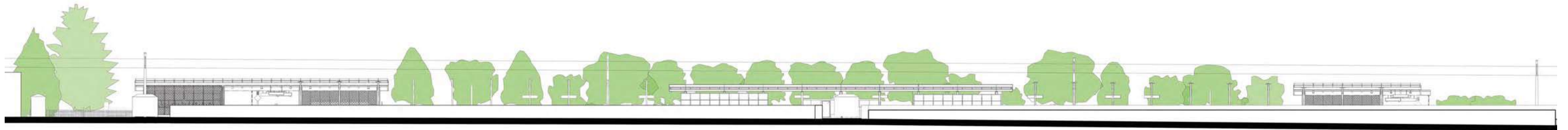

WEST ELEVATION

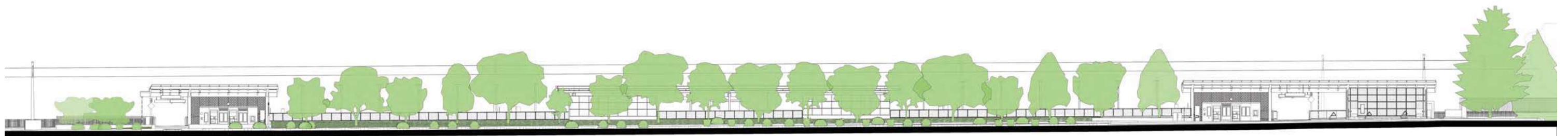

EAST ELEVATION

EAST MAIN STATION
BIKE CAGE ELEVATION - SOUTH
EAST LINK EXTENSION



EAST MAIN STATION
BIKE CAGE ELEVATION - NORTH
EAST LINK EXTENSION



EAST MAIN STATION NEIGHBORHOOD PHOTOS

EAST LINK EXTENSION



EAST MAIN STATION SOUTH PLAZA VIEW

EAST LINK EXTENSION



EAST MAIN STATION
NORTH PLAZA VIEW
EAST LINK EXTENSION



EAST MAIN STATION
PLATFORM VIEW
EAST LINK EXTENSION



EAST MAIN STATION
PORTAL VIEW
EAST LINK EXTENSION



SOUND TRANSIT

EAST LINK EXTENSION

SOUTH PORTAL

SPEB & SOUTH PORTAL
VIEW FROM TRACKS
EAST LINK EXTENSION

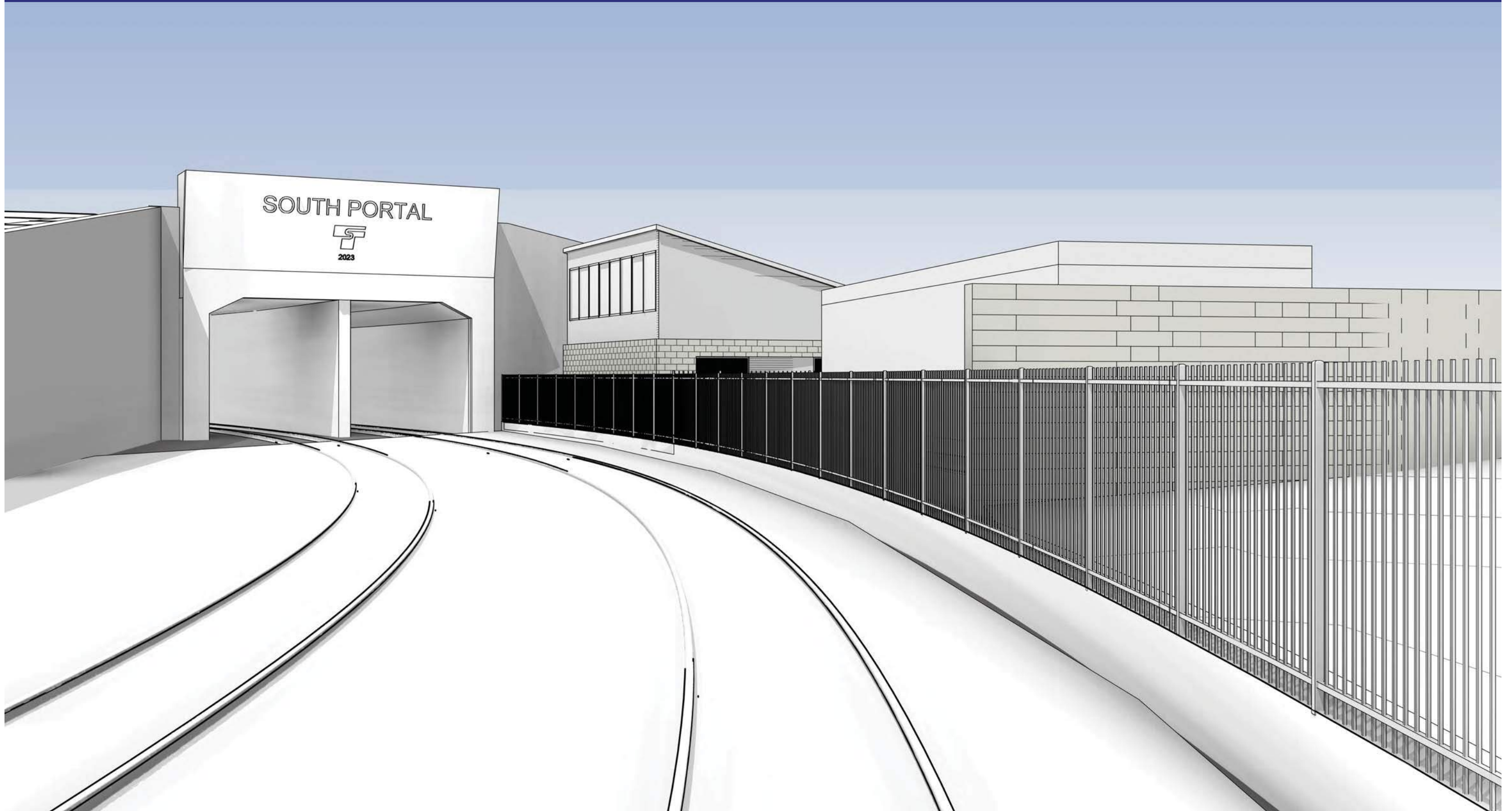

SOUND TRANSIT

EAST LINK EXTENSION

SPEB

SPEB SITE PLAN EAST LINK EXTENSION

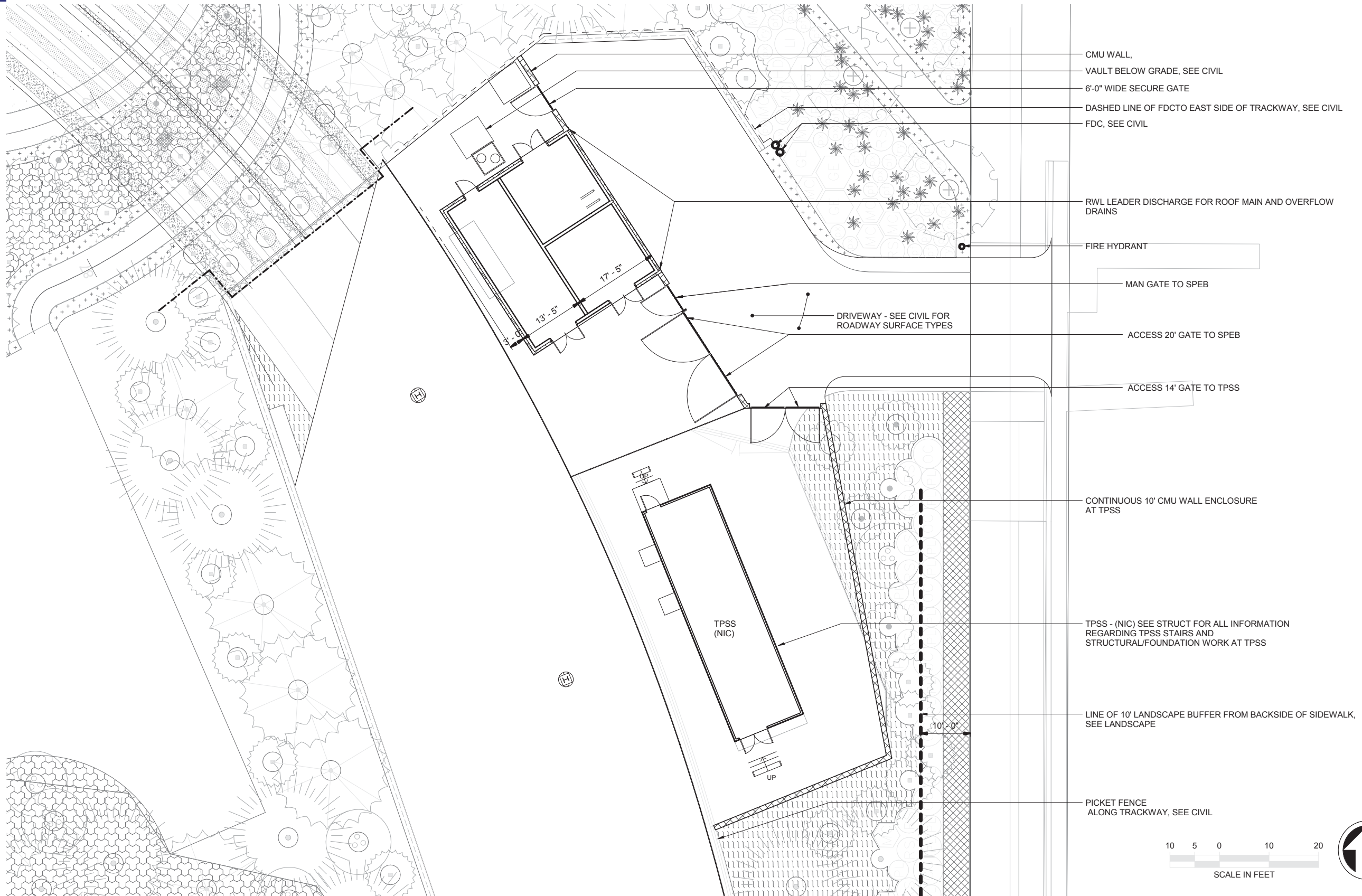

SPEB ELEVATION FROM 112th EAST LINK EXTENSION

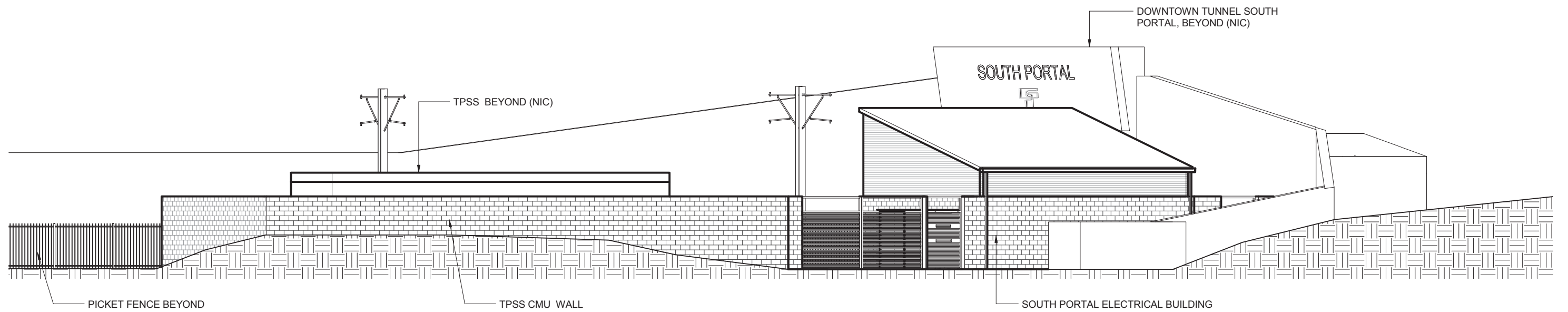

SPEB ELEVATIONS EAST LINK EXTENSION

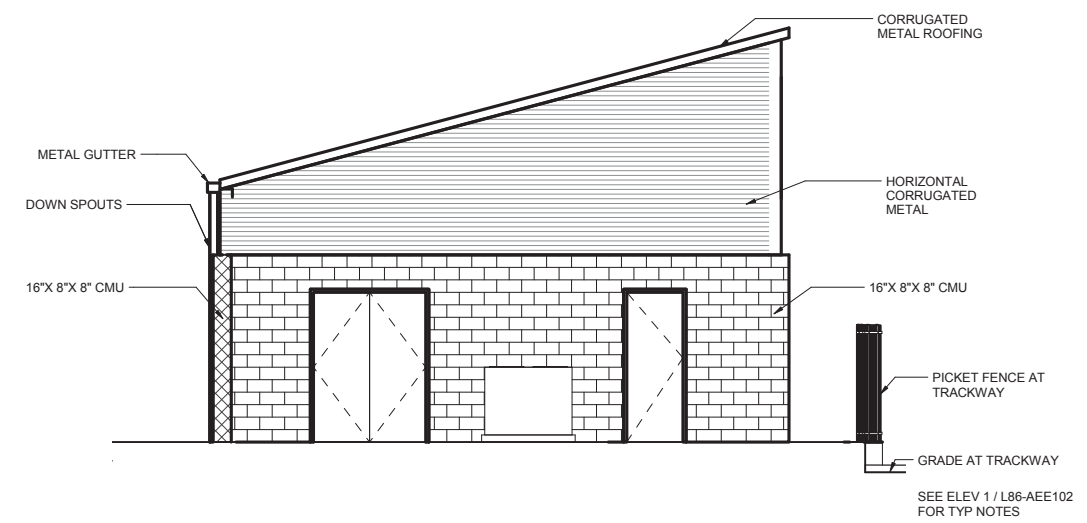
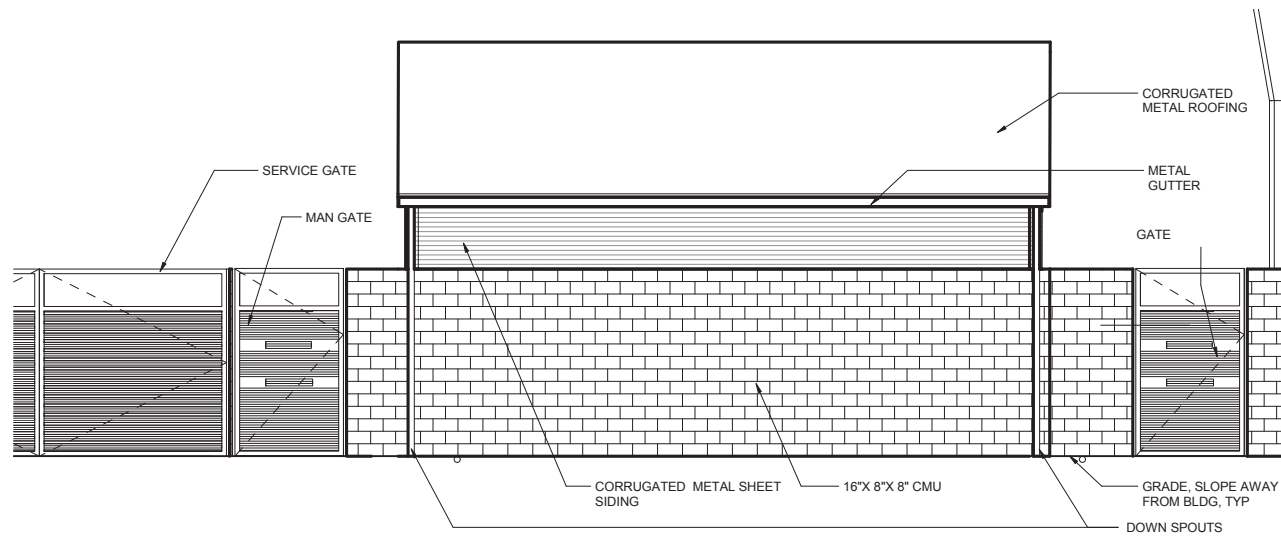
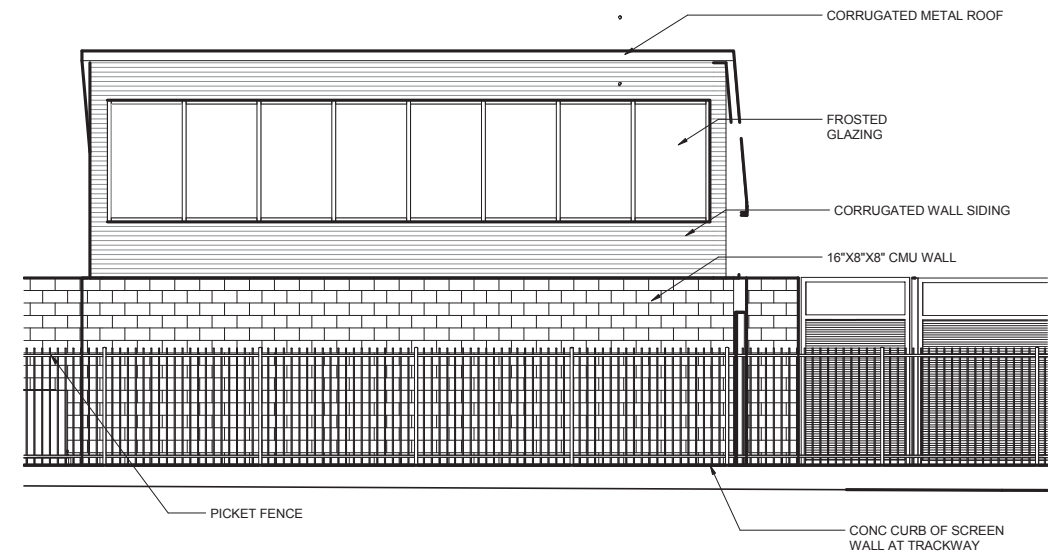
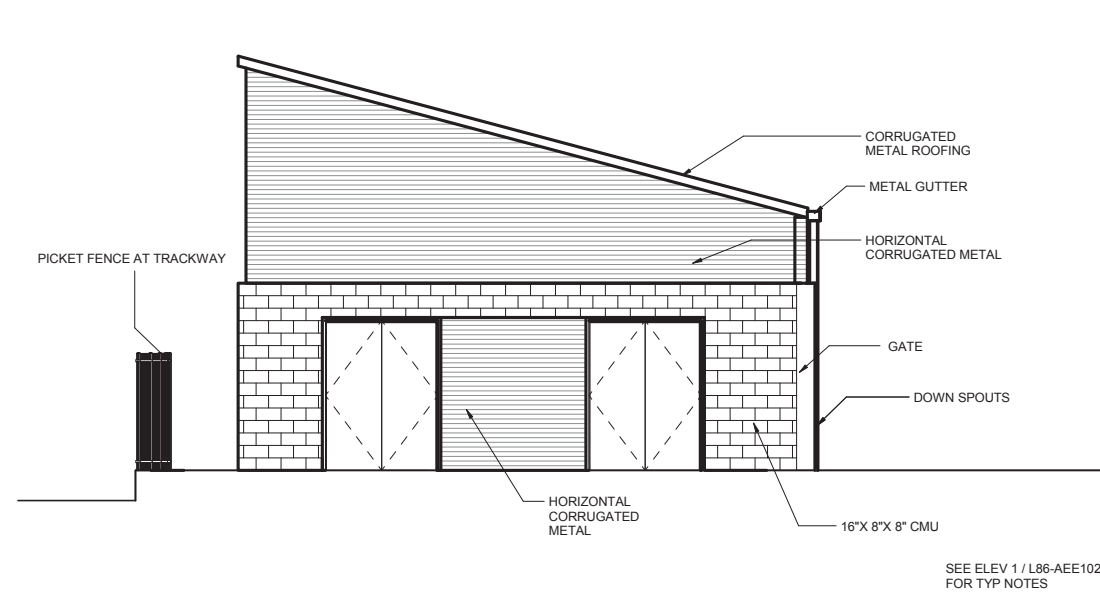

SPEB
VIEW FROM 112TH

EAST LINK EXTENSION



SPEB VIEW FROM 112TH

EAST LINK EXTENSION



SOUND TRANSIT

EAST LINK EXTENSION

ACCESS SHAFT HEADHOUSE

ACCESS SHAFT HEADHOUSE SITE PLAN EAST LINK EXTENSION

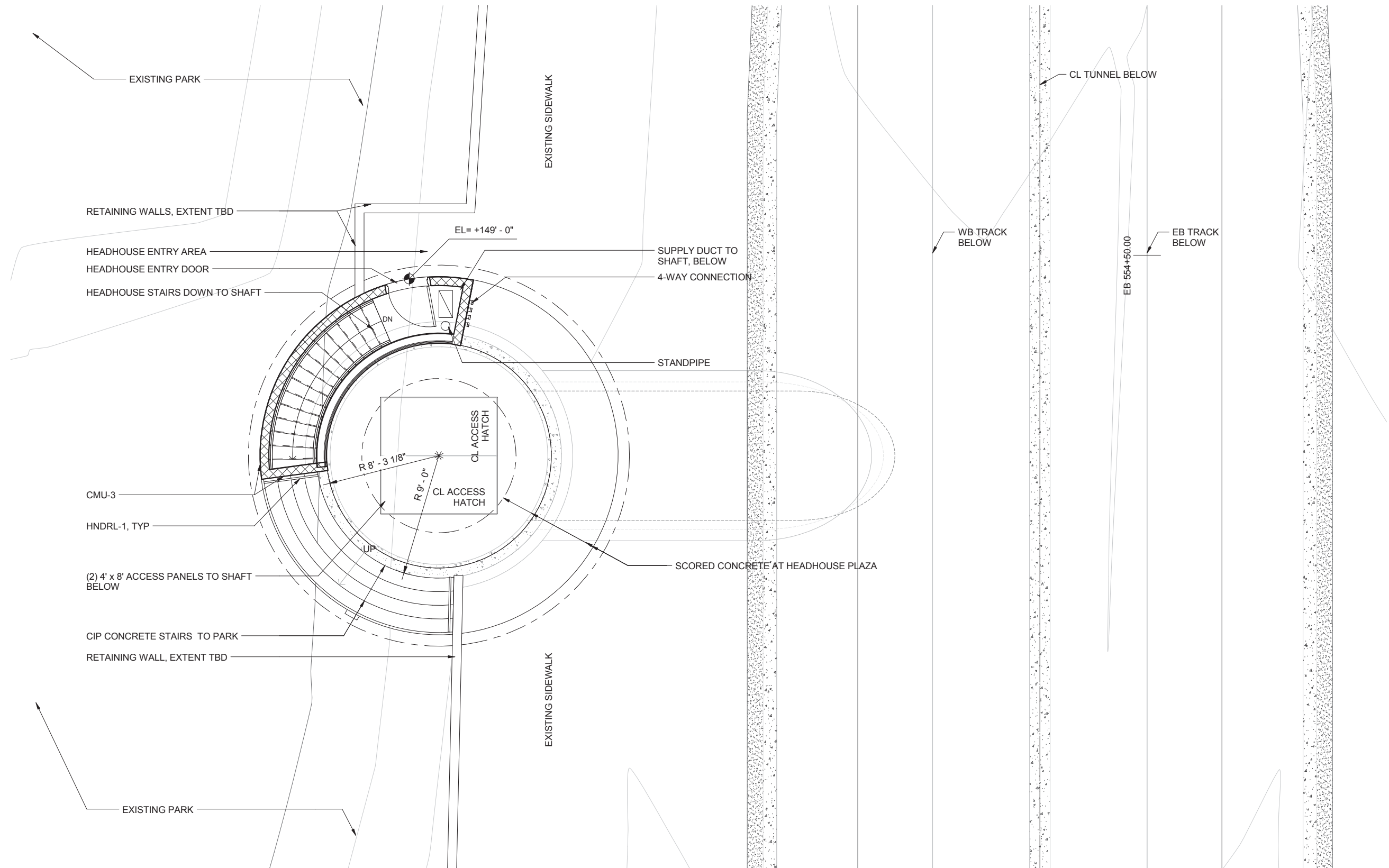

ACCESS SHAFT HEADHOUSE
AERIAL VIEW
EAST LINK EXTENSION



ACCESS SHAFT HEADHOUSE
AERIAL VIEW
EAST LINK EXTENSION



ACCESS SHAFT HEADHOUSE
GROUND VIEW
EAST LINK EXTENSION



ACCESS SHAFT HEADHOUSE
GROUND VIEW
EAST LINK EXTENSION



SOUND TRANSIT

EAST LINK EXTENSION

BTC STATION

BTC STATION NEIGHBORHOOD CONTEXT PLAN

EAST LINK EXTENSION

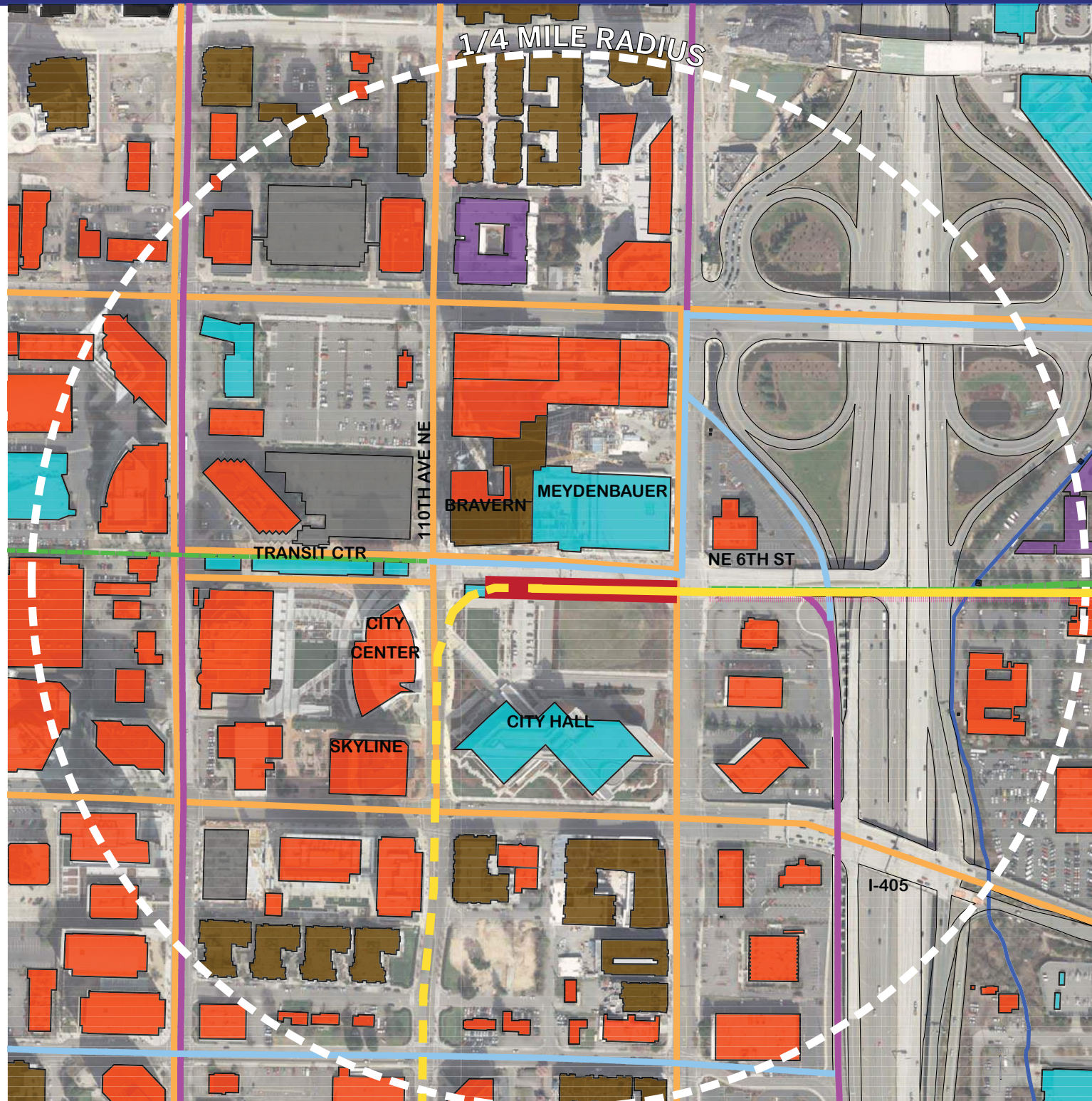





LEGEND

-  BUS ROUTE
-  BICYCLE ROUTE
-  BICYCLE LANE
-  OFF STREET PATH
-  LIGHT RAIL TRACKS
-  STATION

 PATRON CATCHMENT AREA

CITY OF BELLEVUE - 2009 PEDESTRIAN & BICYCLE TRANSPORTATION PLAN

-  COMMERCIAL
-  CIVIC / INSTITUTIONAL
-  MULTI-FAMILY RESIDENTIAL
-  HOTEL
-  PARKING STRUCTURE



BTC STATION SITE PLAN

EAST LINK EXTENSION

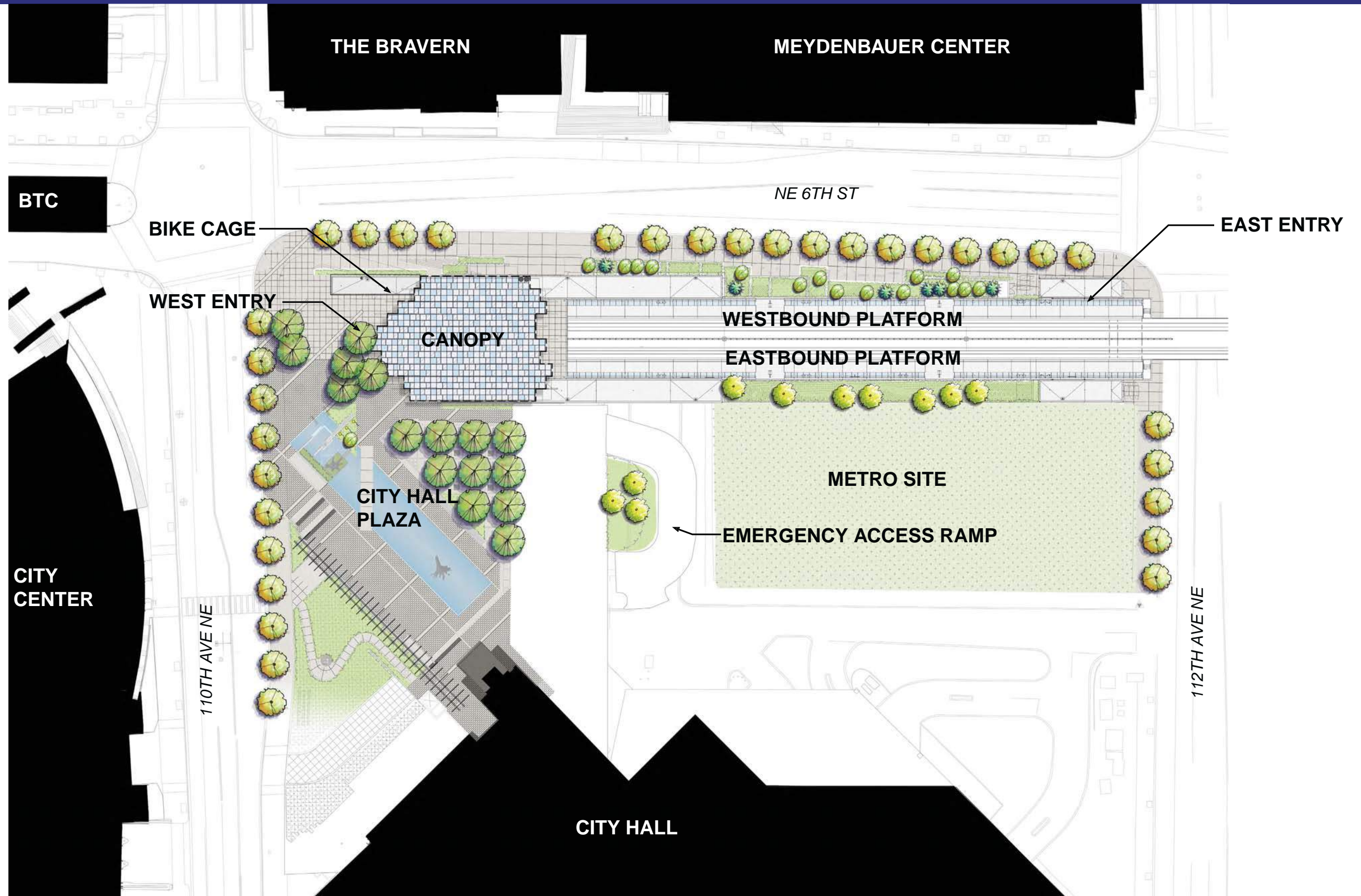

BTC STATION LONGITUDINAL SECTION EAST LINK EXTENSION

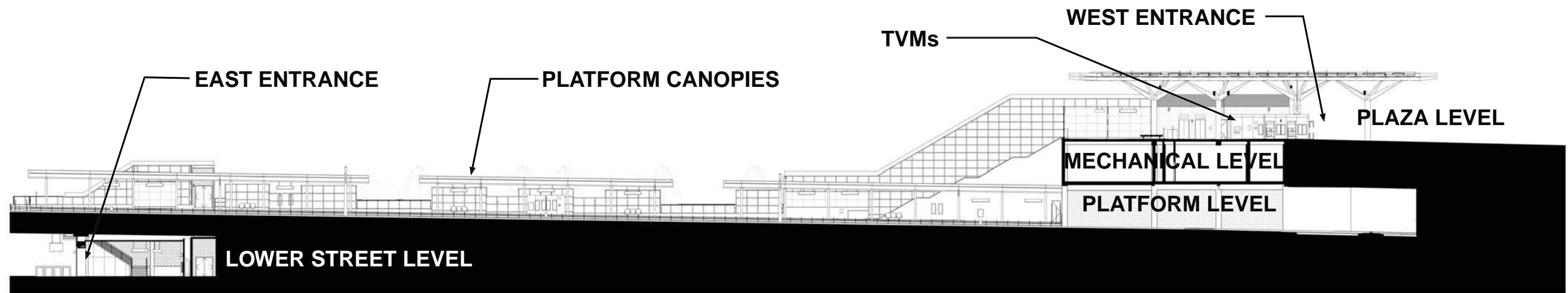

SECTION B-B

BTC STATION WEST ENTRY PLAN EAST LINK EXTENSION

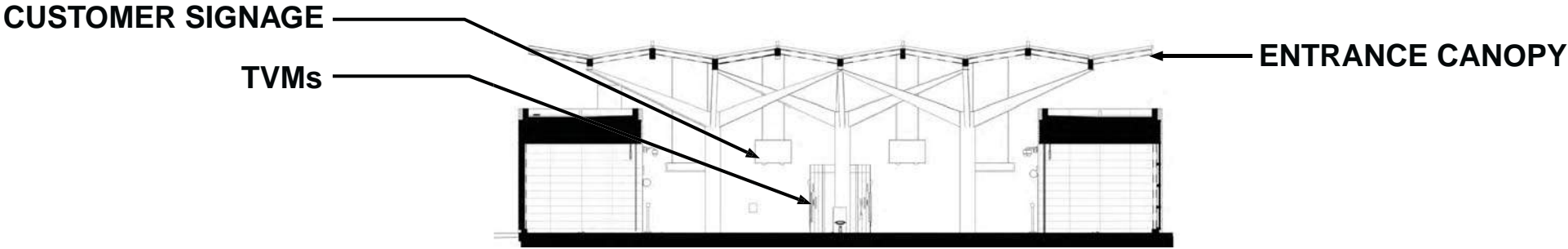
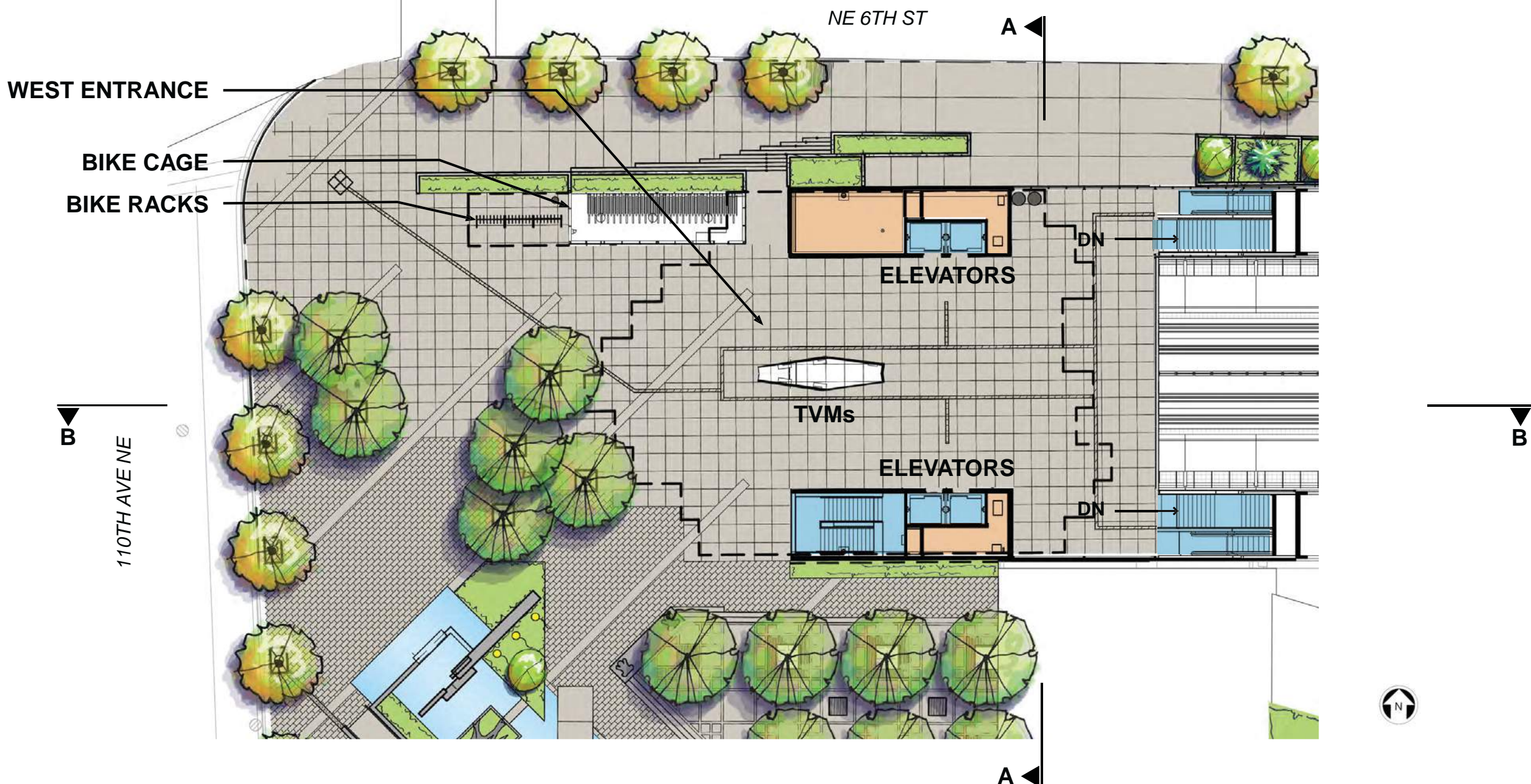

SECTION A-A

BTC STATION MEZZANINE & PLATFORM LEVEL PLANS EAST LINK EXTENSION

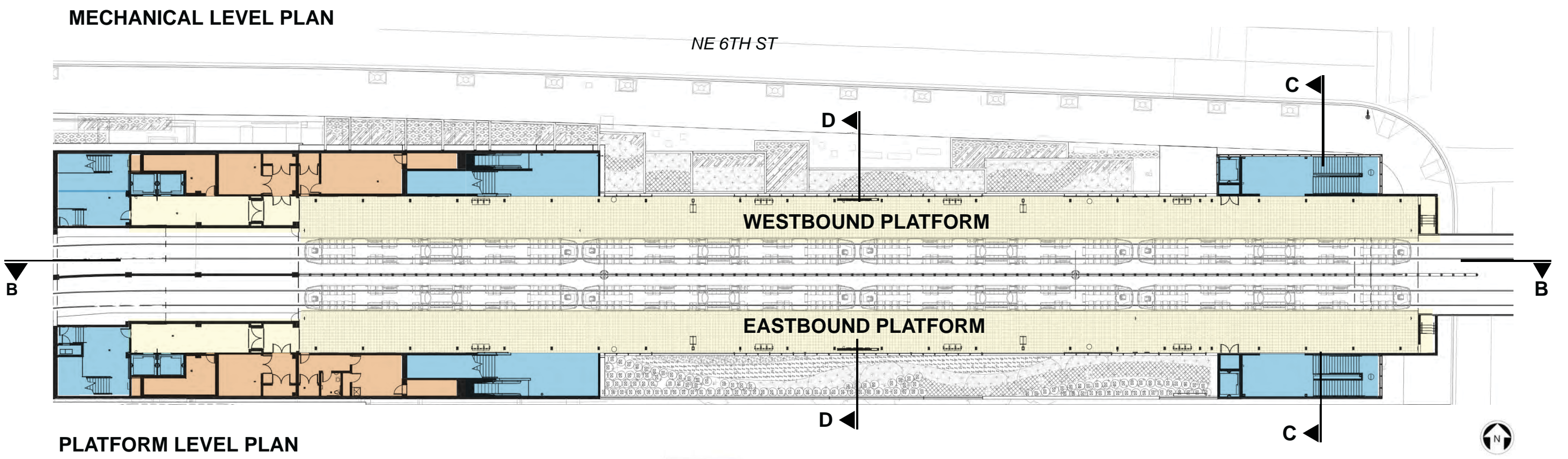
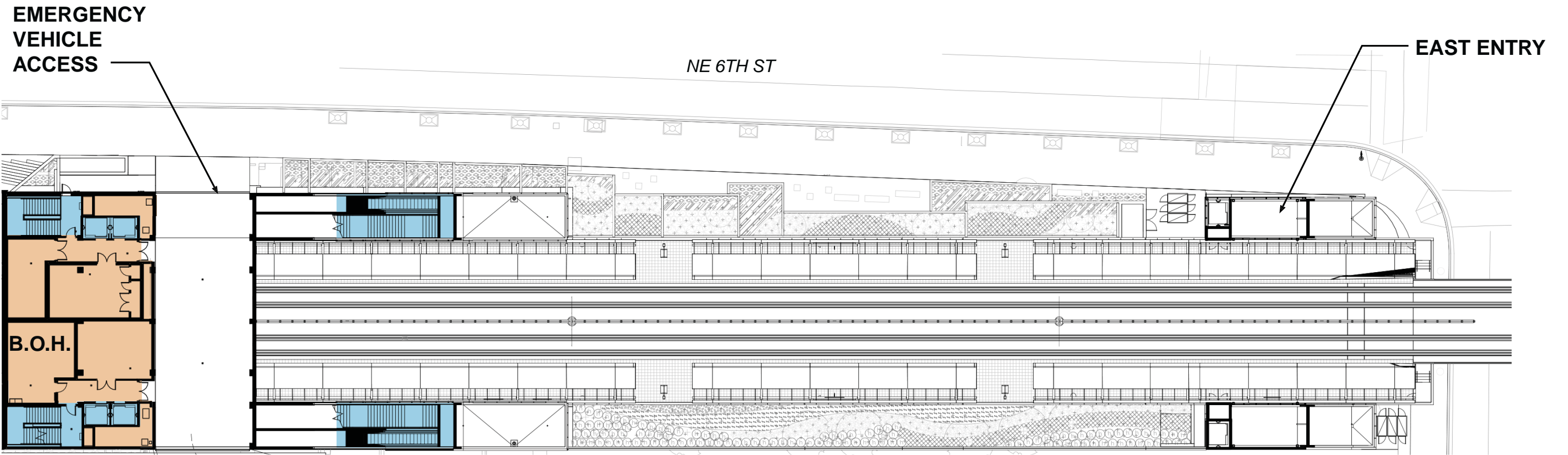

BTC STATION LOWER STREET LEVEL PLAN EAST LINK EXTENSION

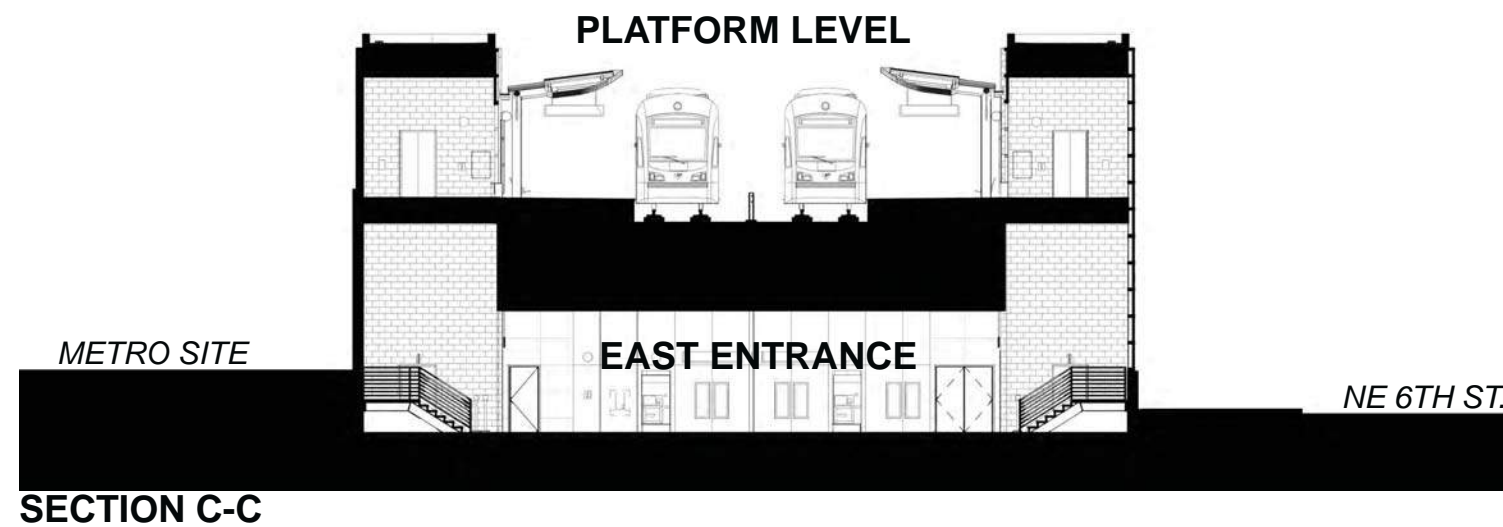
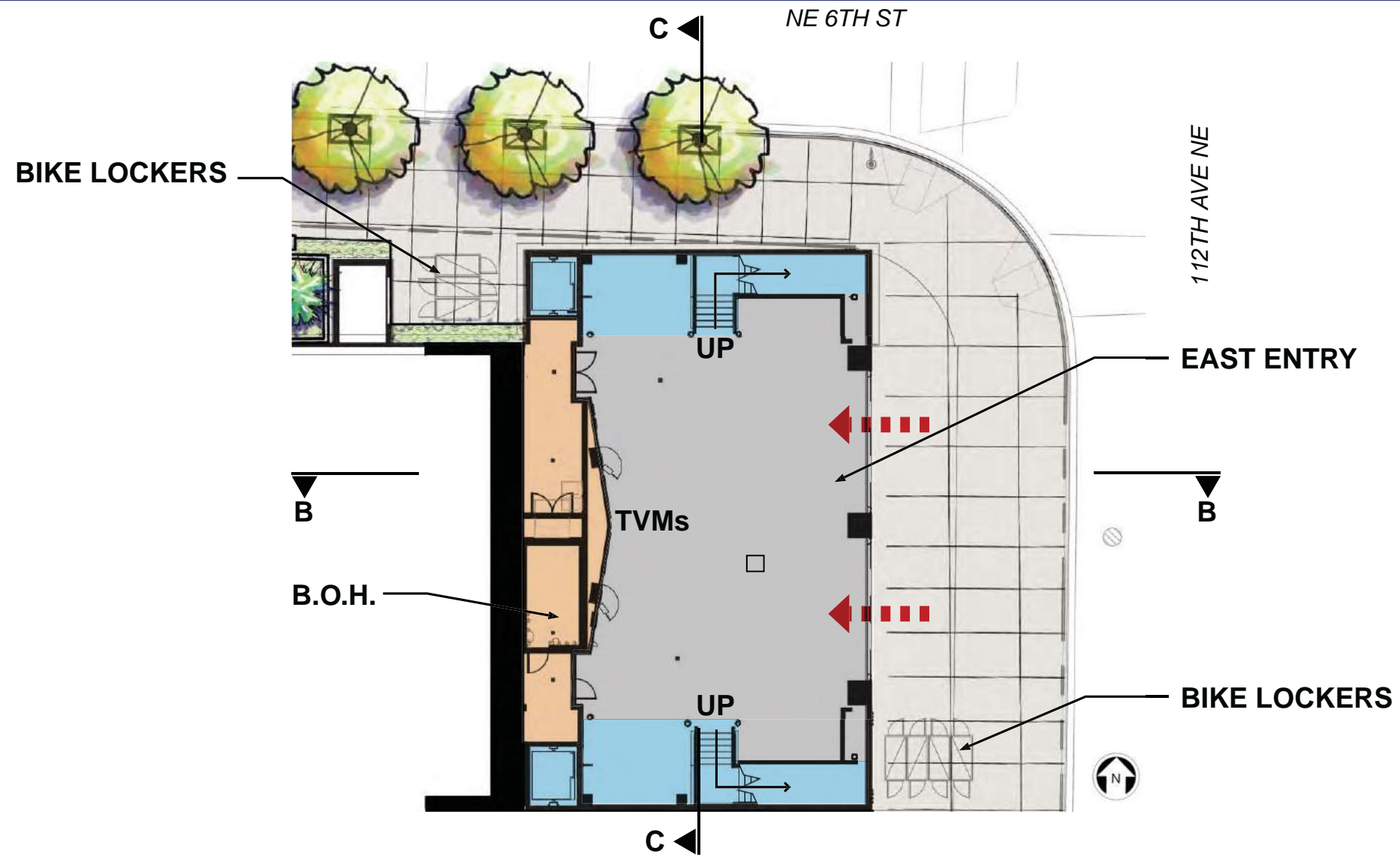

BTC STATION CROSS SECTIONS EAST LINK EXTENSION

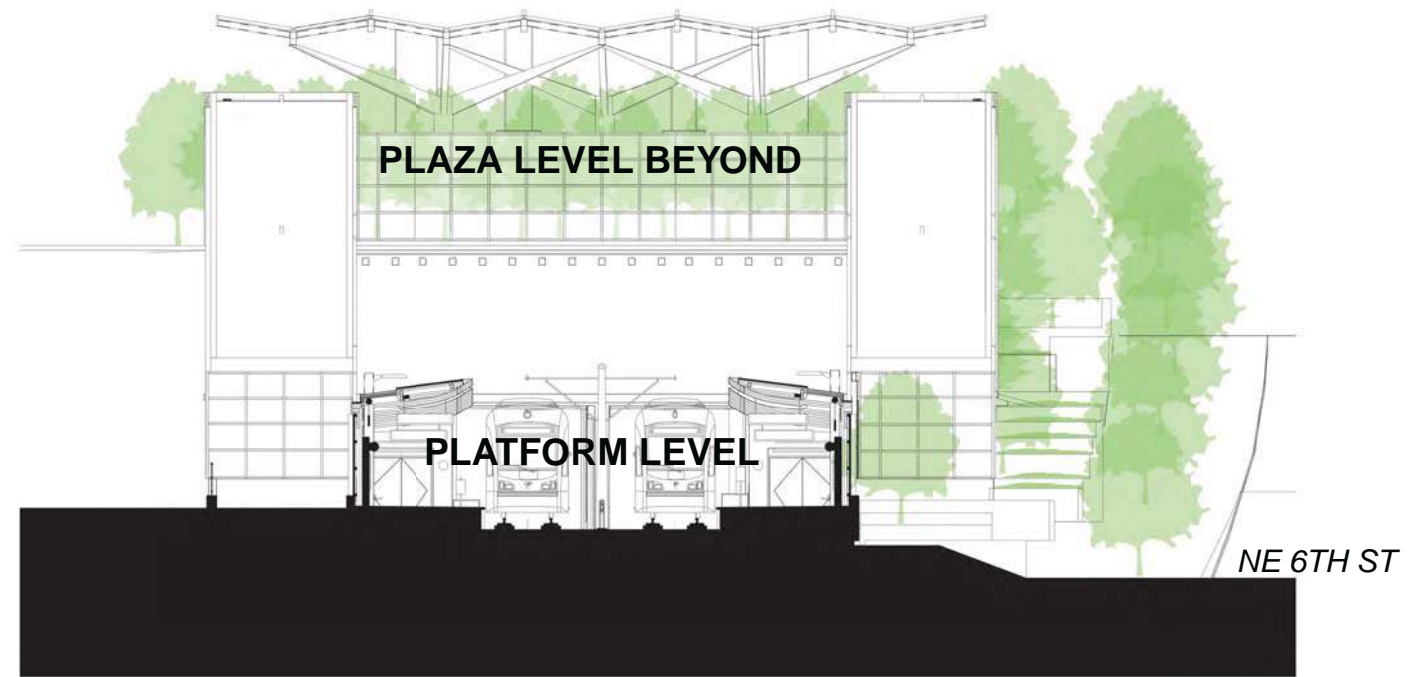

SECTION D-D

BTC STATION NORTH & SOUTH ELEVATIONS

EAST LINK EXTENSION

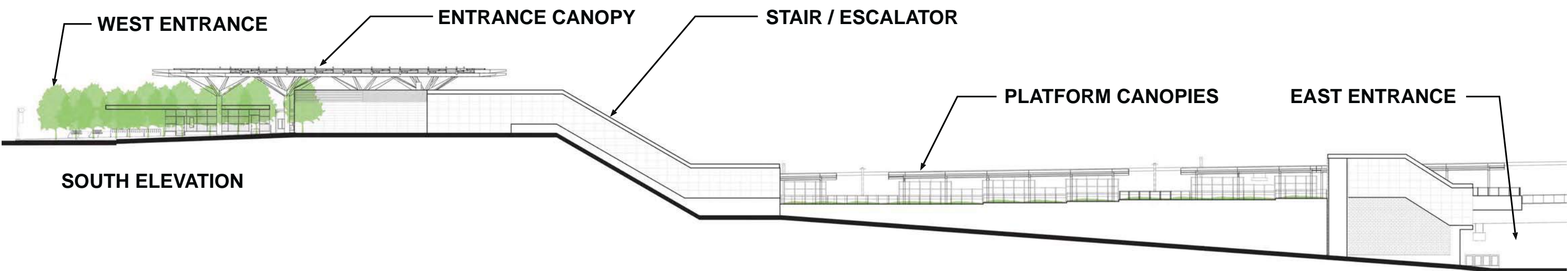
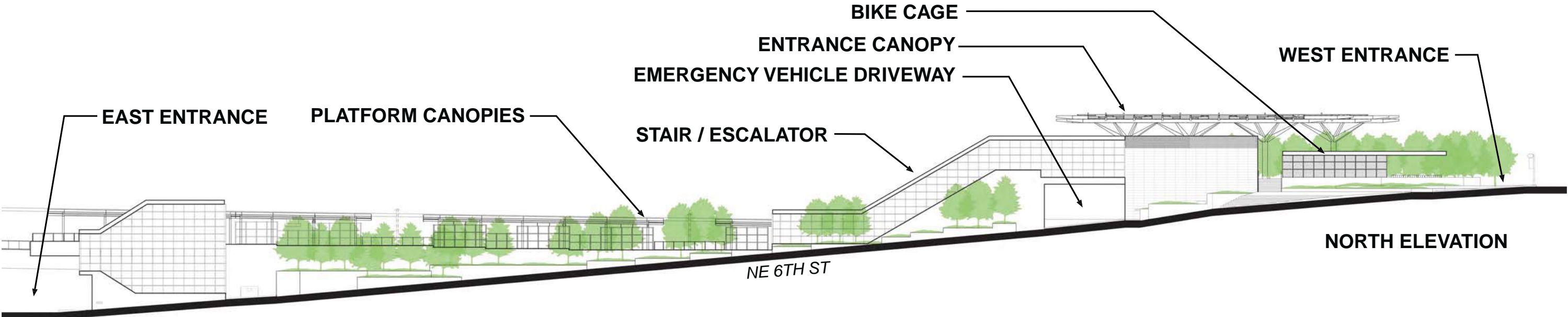

BTC STATION
EAST ELEVATION
EAST LINK EXTENSION

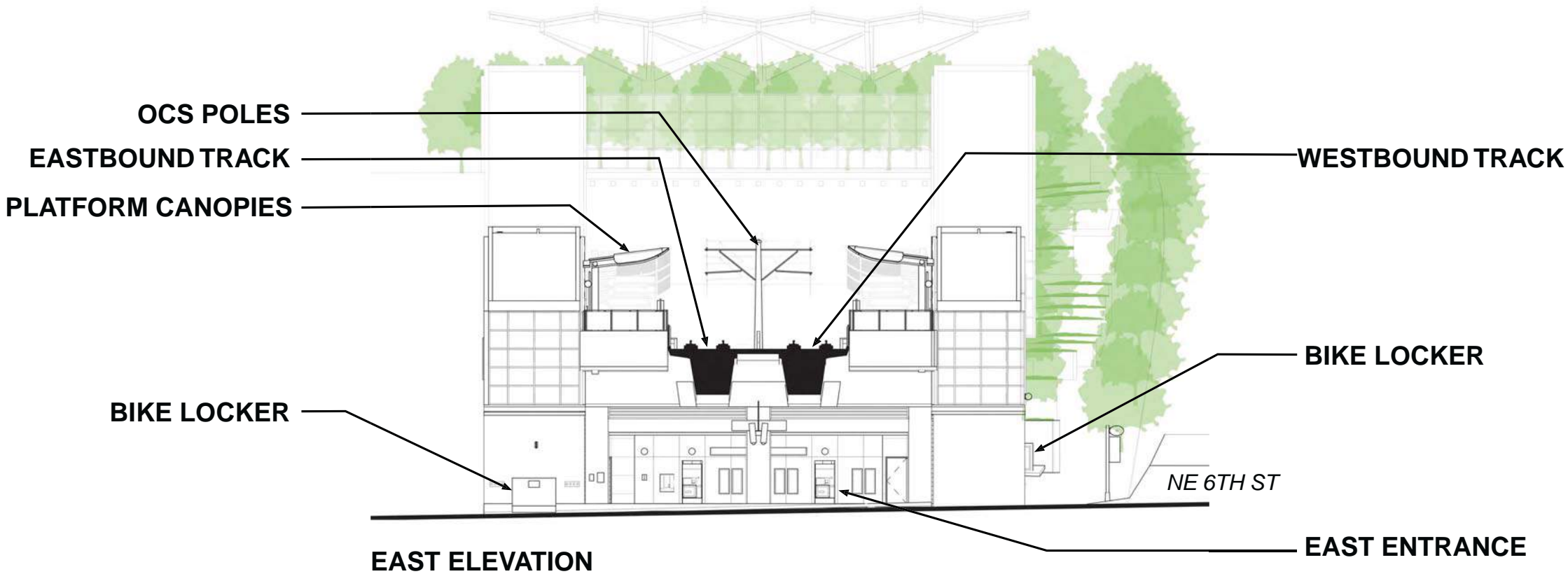

BTC STATION
EAST ENTRY VIEW
EAST LINK EXTENSION



BTC STATION
PLATFORM VIEW
EAST LINK EXTENSION

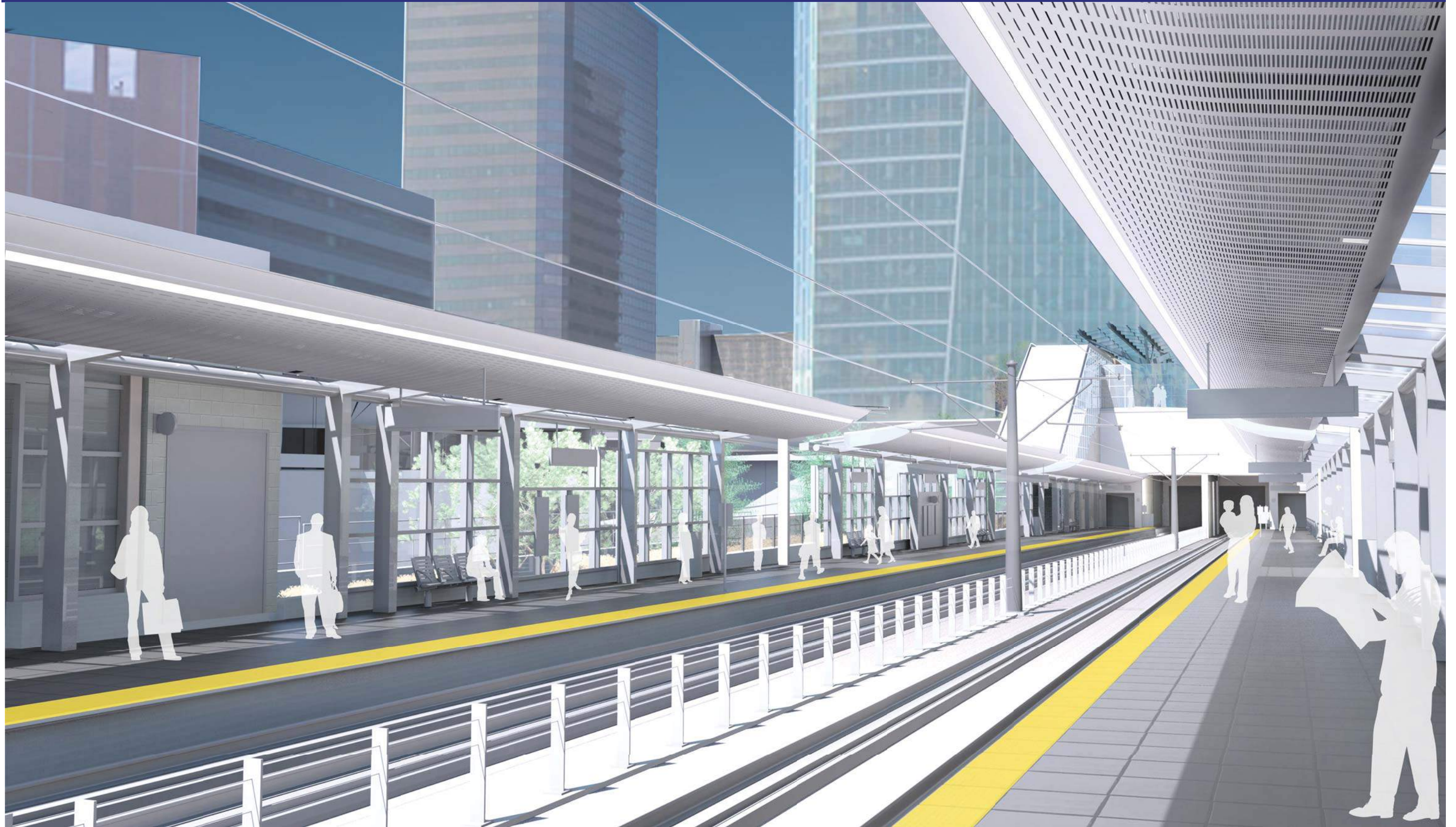

BTC STATION
WEST ENTRY VIEW
EAST LINK EXTENSION



BTC STATION
AERIAL VIEW FROM BTC
EAST LINK EXTENSION



Hospital Station

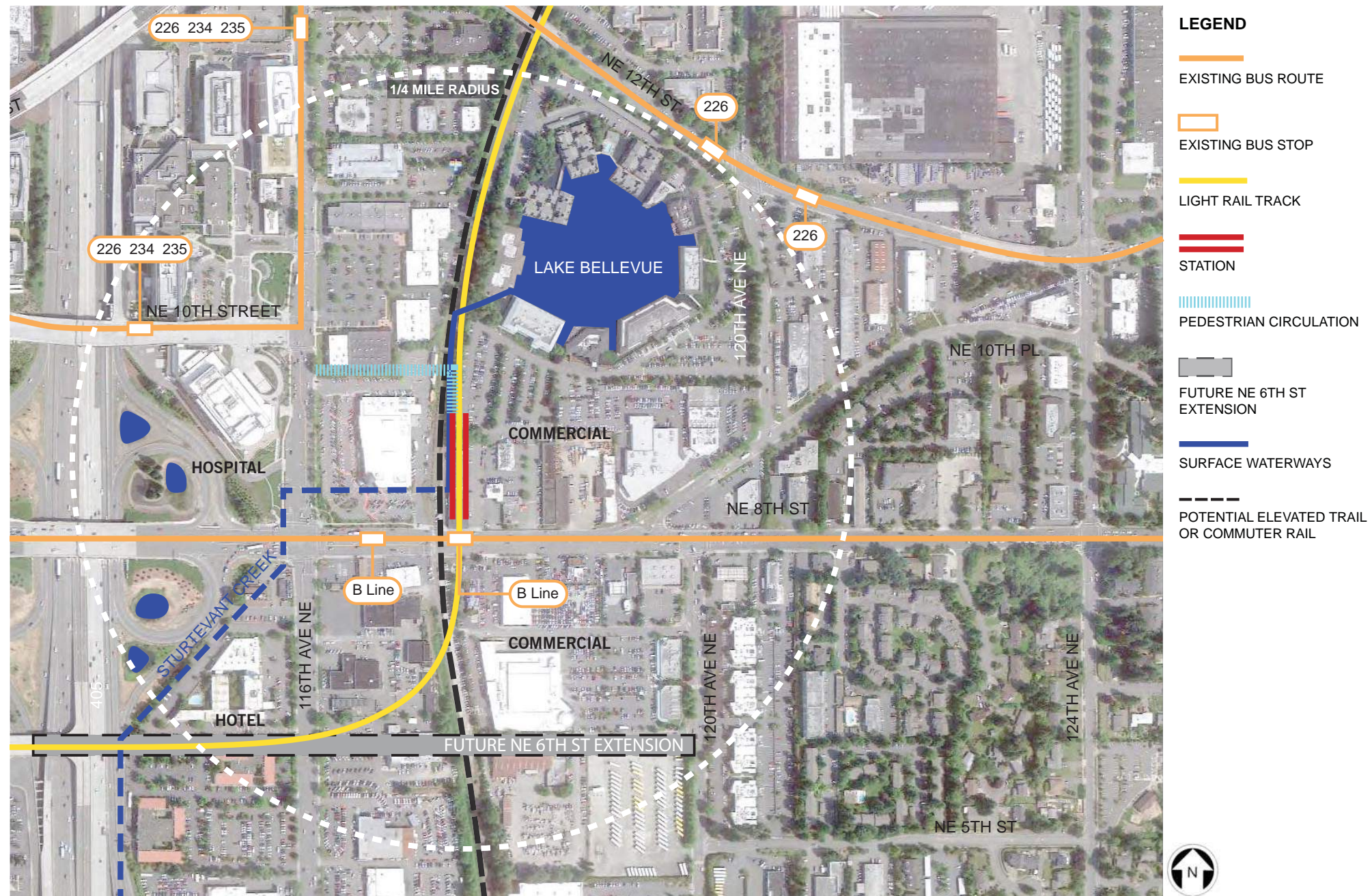

Hospital Station



Station View Looking Northwest

Hospital Station



Station North Entrance

Hospital Station



Platform View Looking South

Hospital Station

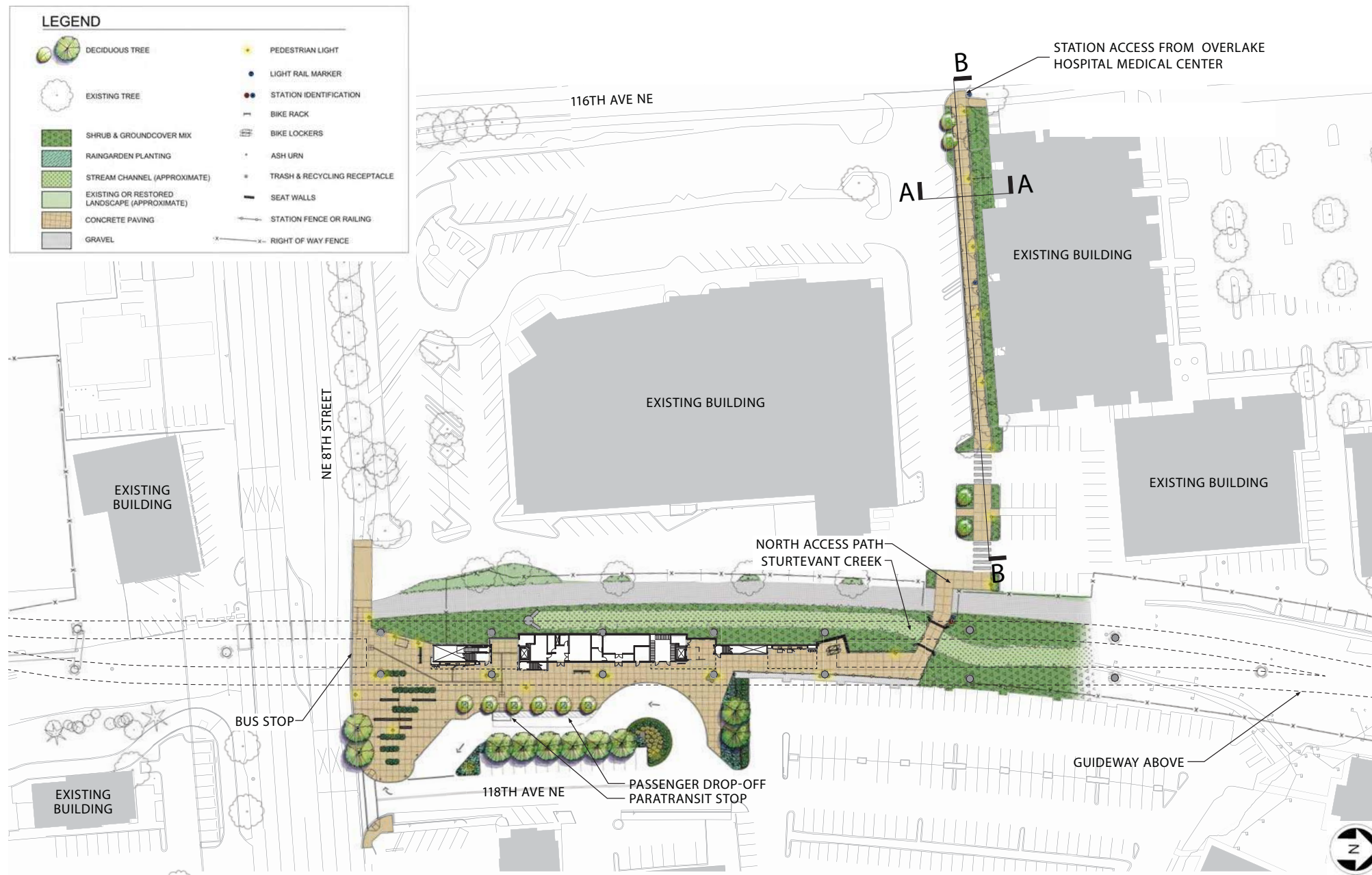

Hospital Station

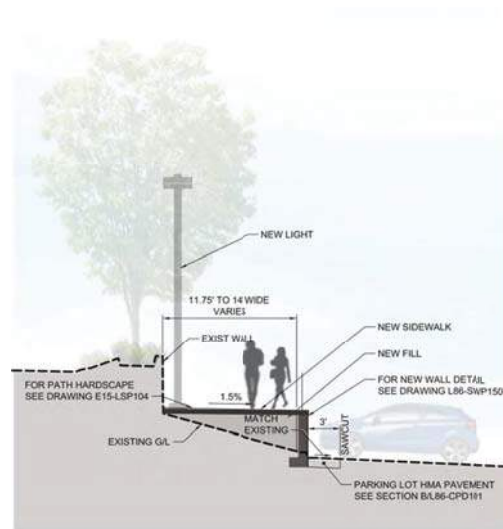

SITE SECTION AA

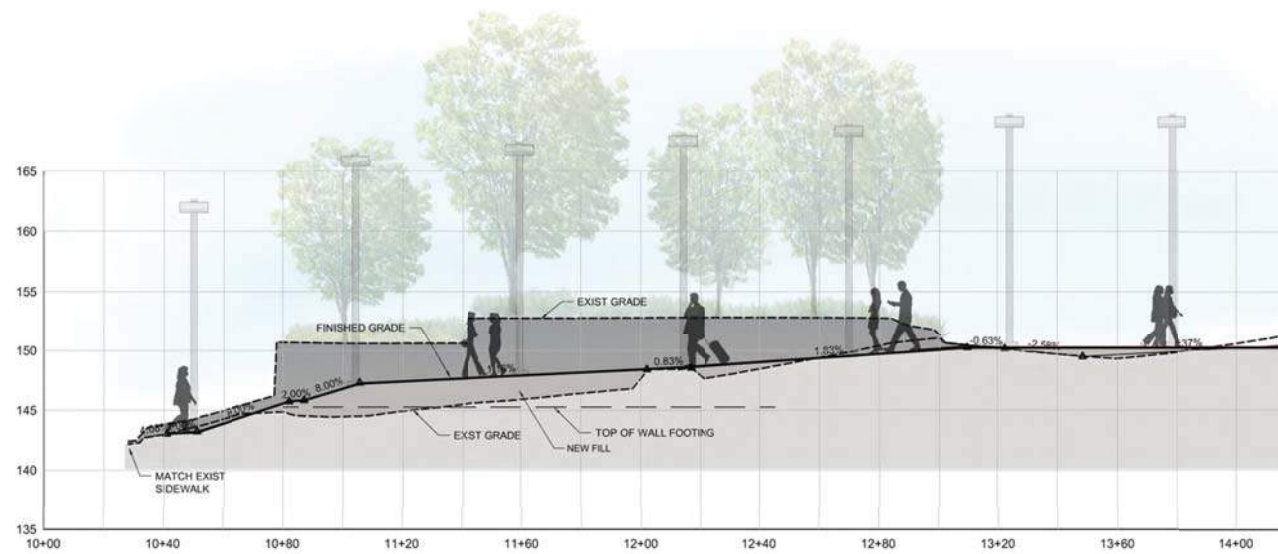

SITE SECTION BB

Hospital Station

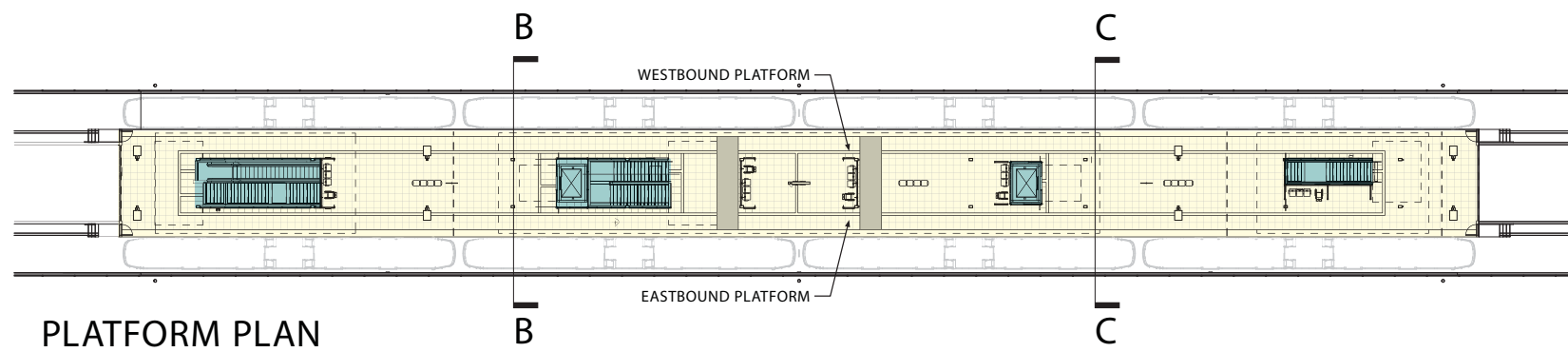

PLATFORM PLAN

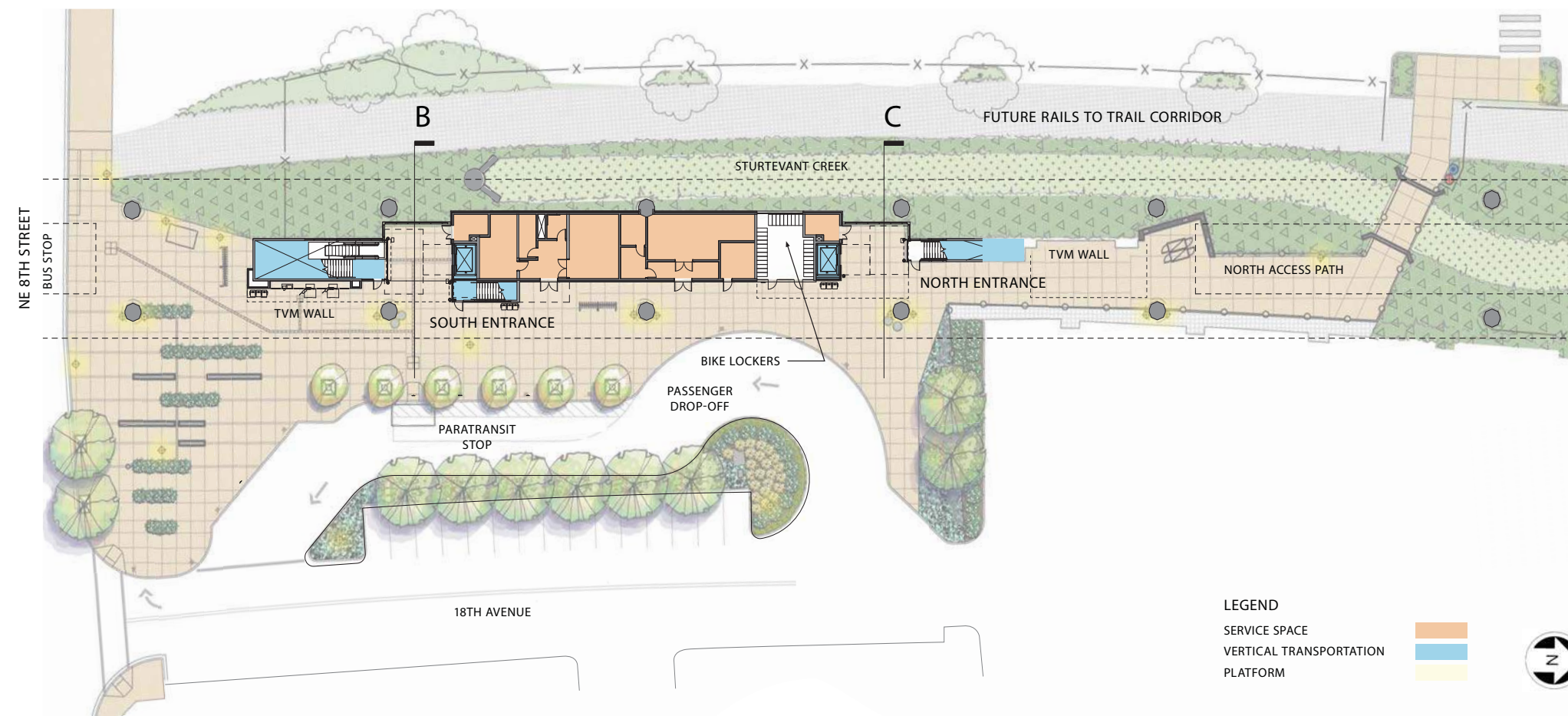

GRADE LEVEL PLAN

Grade Level and Platform Plans

Hospital Station

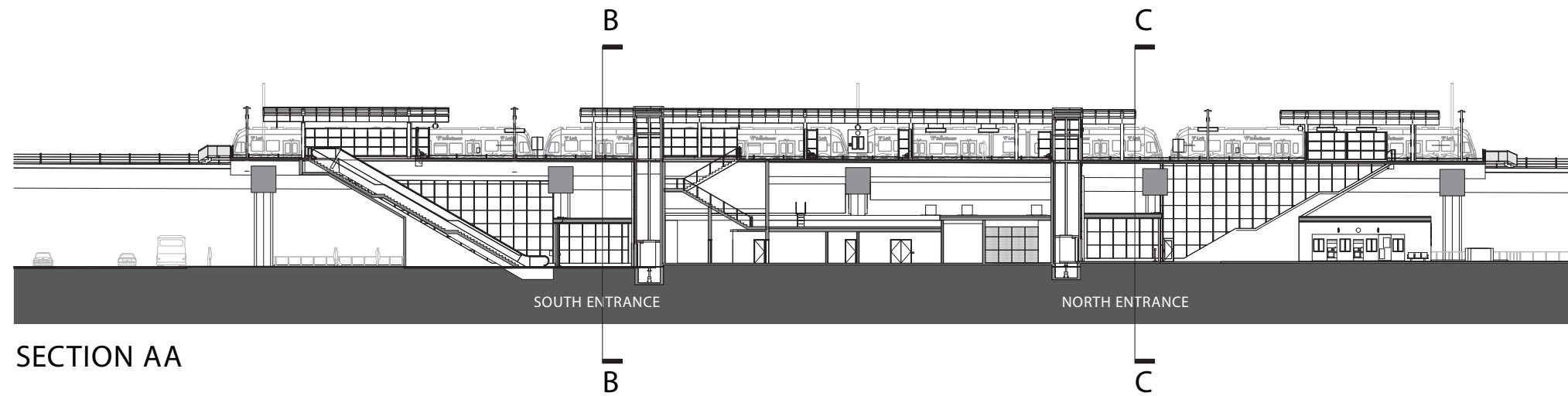

SECTION AA

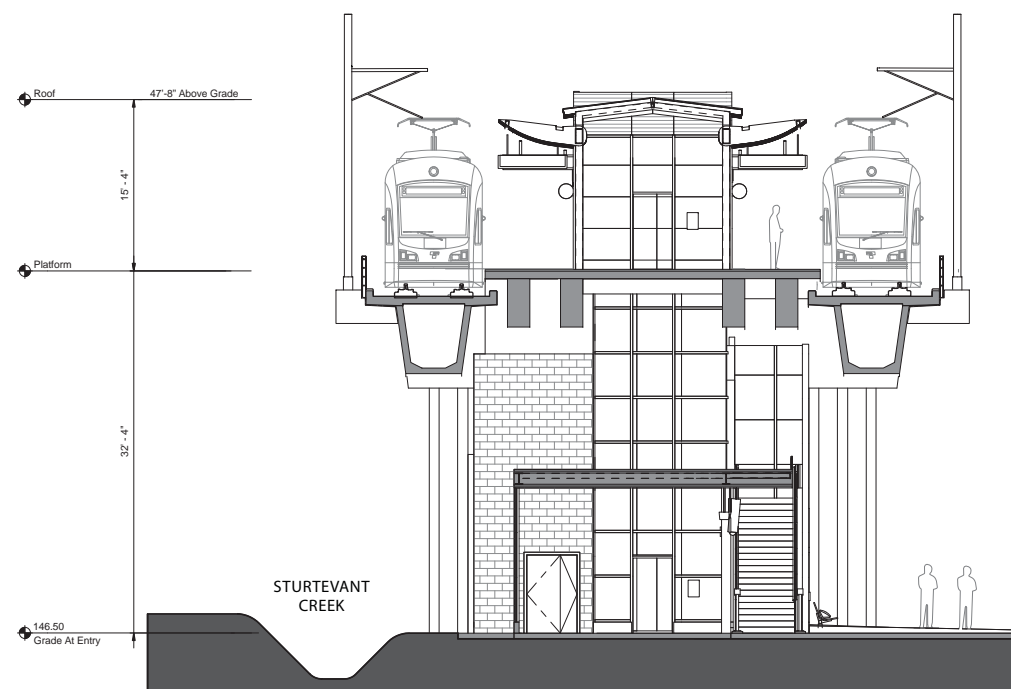

SECTION BB - SOUTH ENTRANCE

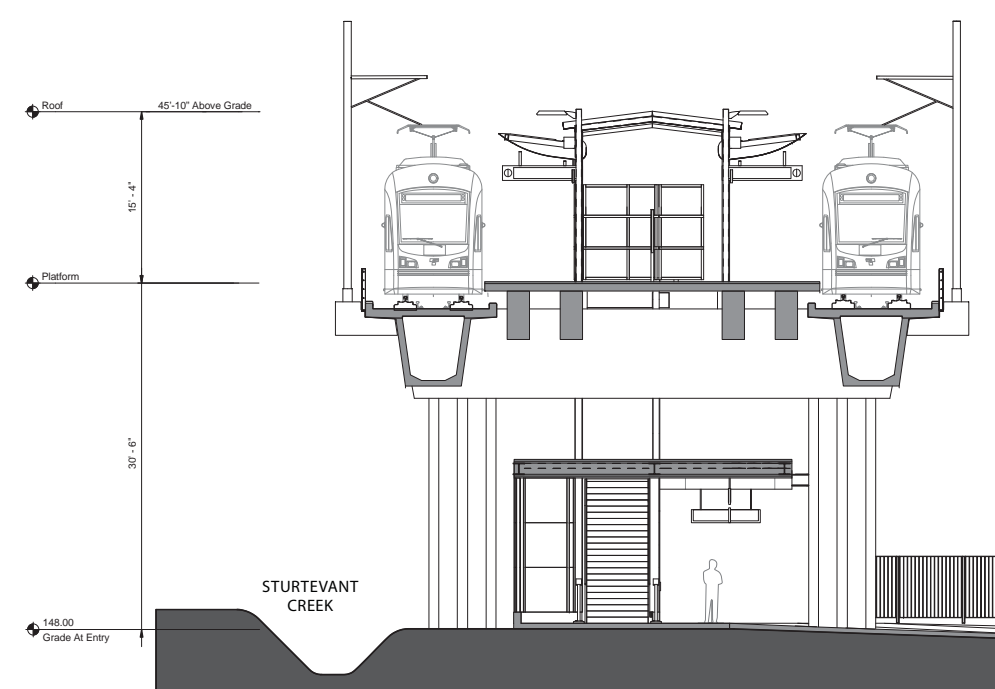

SECTION CC - NORTH ENTRANCE

Hospital Station

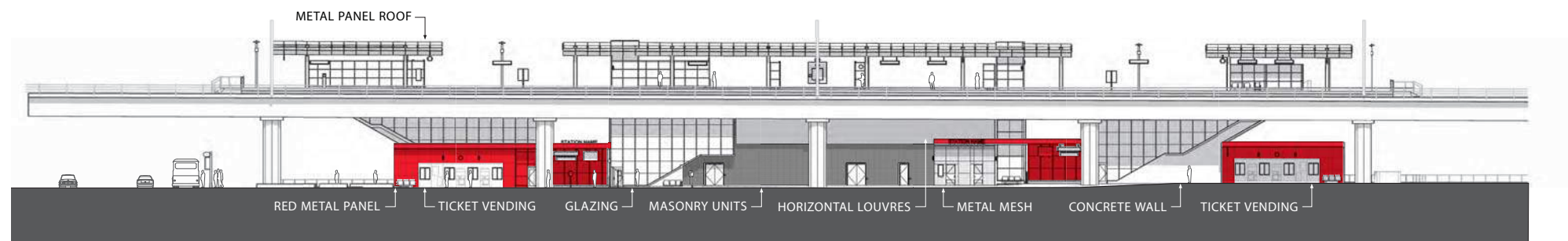

EAST ELEVATION

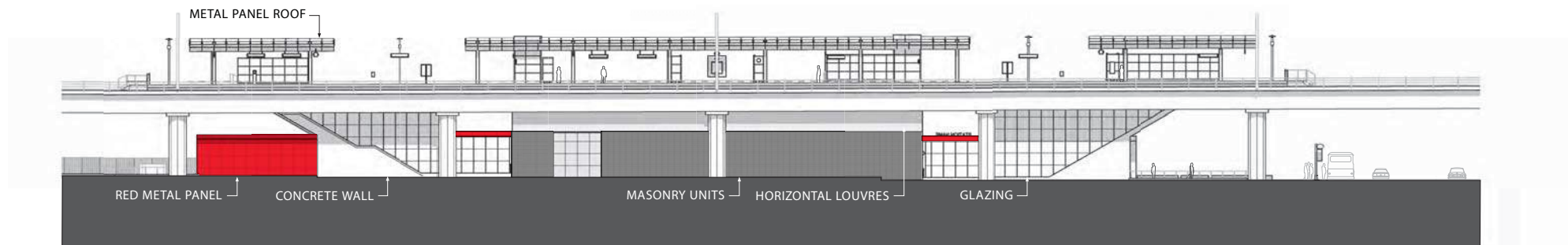

WEST ELEVATION

Hospital Station

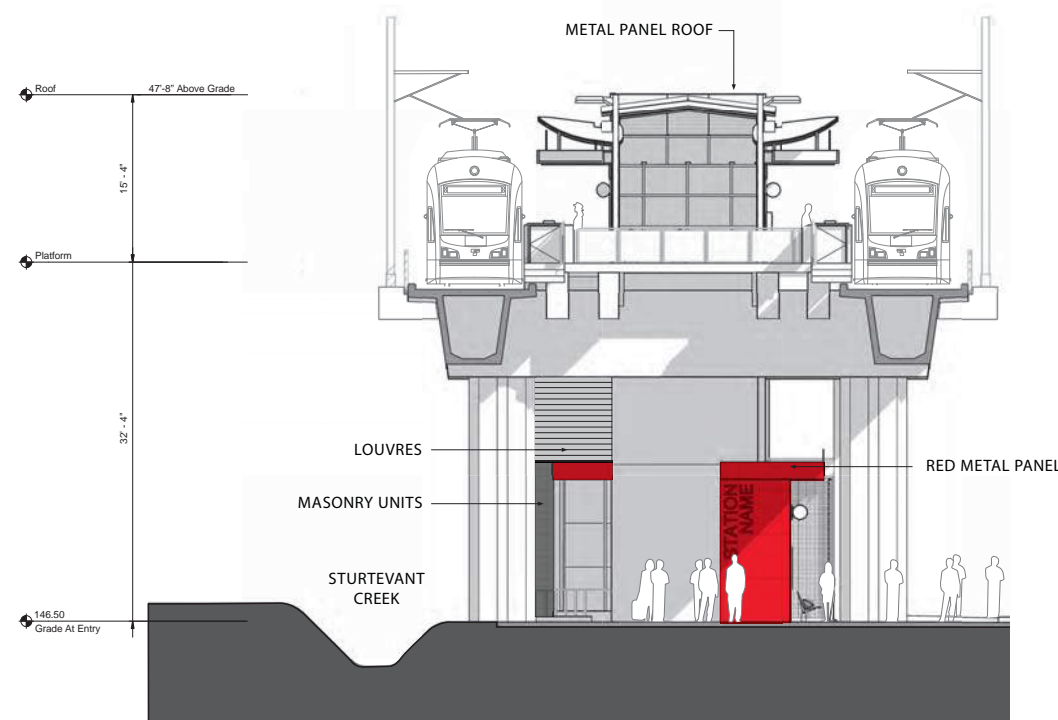

SOUTH ELEVATION

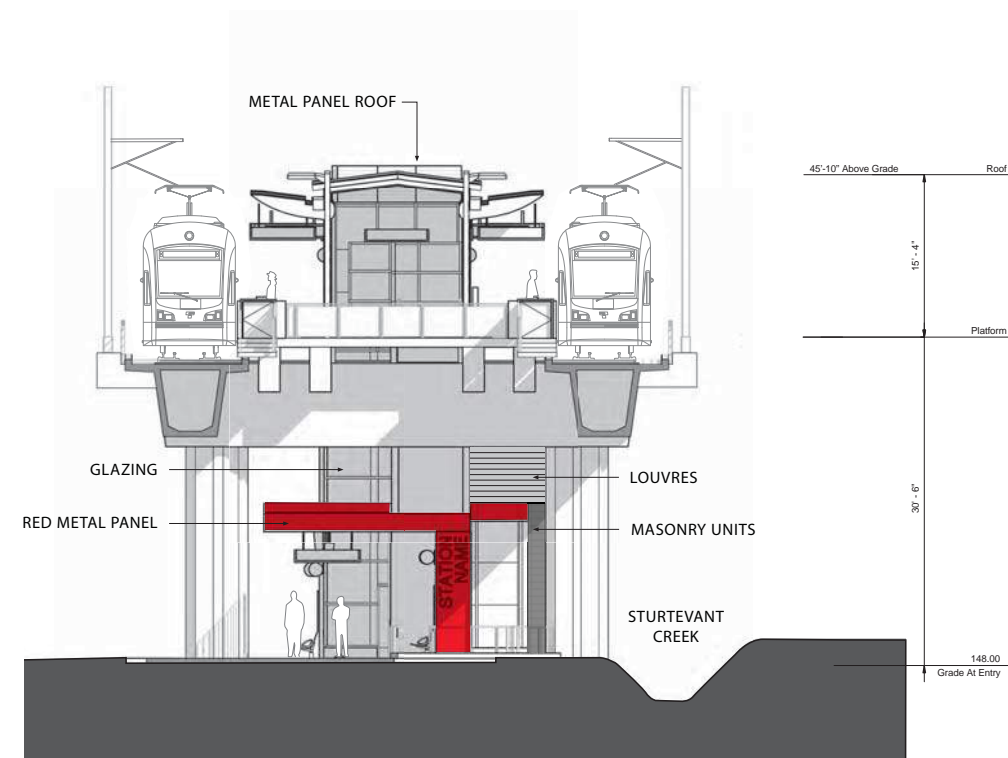

NORTH ELEVATION

Hospital Station

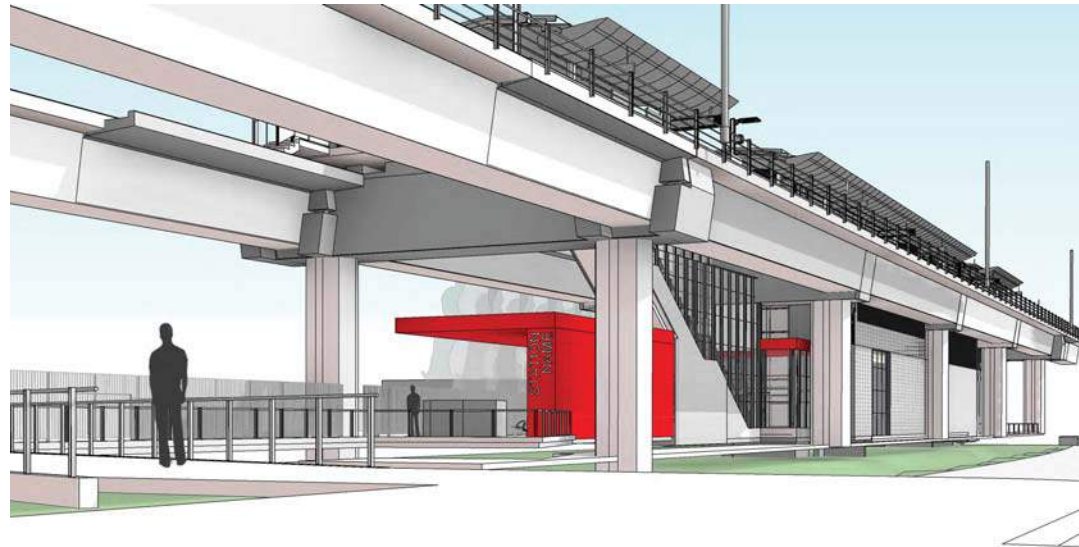

APPROACHING STATION FROM NORTH ACCESS PATH AT EDGE OF WHOLE FOODS PARKING LOT

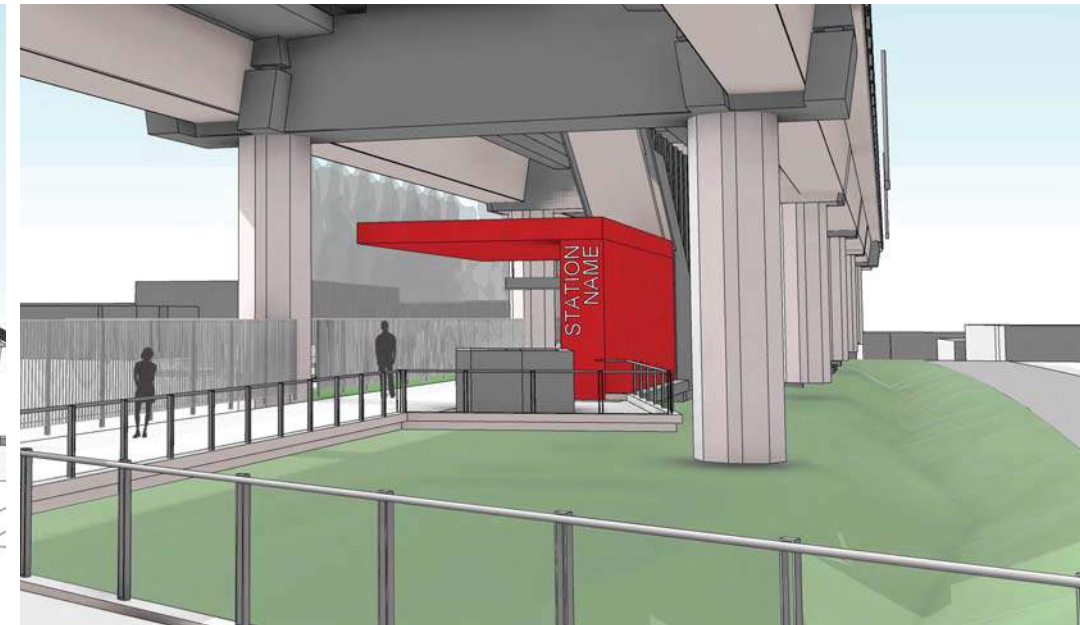

APPROACHING STATION FROM NORTH ACCESS PATH ON BRIDGE CROSSING STRUTEVANT CREEK



APPROACHING STATION FROM NORTH ACCESS PATH AT TICKET VENDING MACHINES

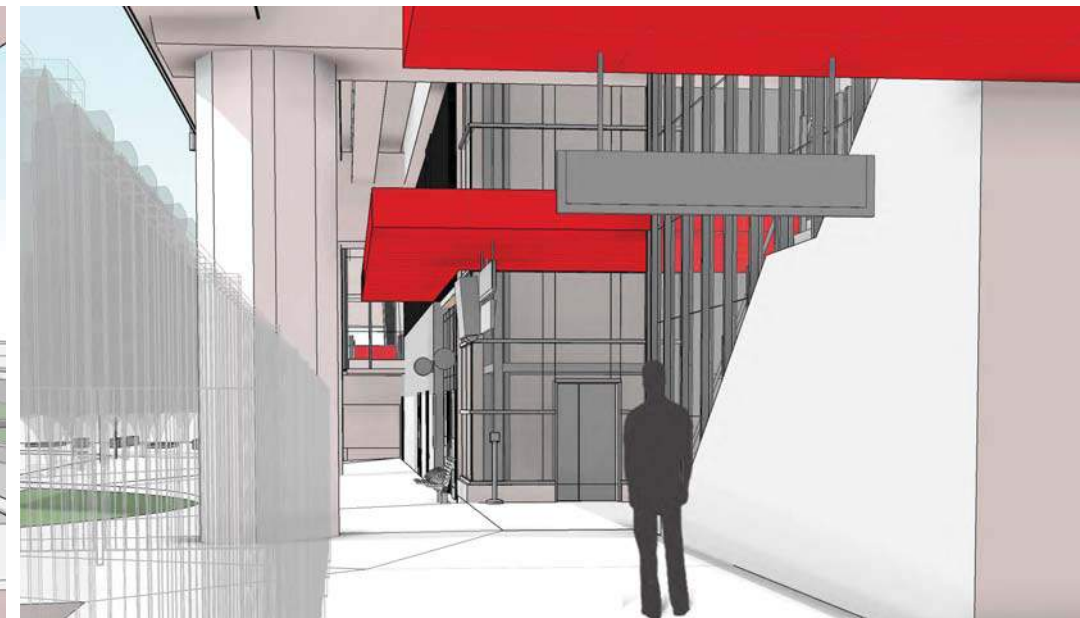

APPROACHING STATION FROM NORTH ACCESS PATH ENTERING NORTH STATION ENTRANCE

Approach to North Entrance

Hospital Station

TREES



Ginkgo Tree
Ginkgo biloba

Tree proposed for Hospital Station street frontage and parking island, providing fall color.



Venus Dogwood
Cornus kousa x nuttallii
'Venus'

Tree proposed for eastern entrance to the Hospital Station along the vehicular drop-off zone.



SHRUBS & GROUNDCOVERS



Western Sword Fern
Polystichum munitum

Fern proposed as an accent plant within planting mix proposed for sloped planting behind southwestern retaining wall.



Stella de Oro Daylily
Hemerocallis 'Stella de Oro'

Flowering perennial proposed as accent for the Hospital Station parking island.



Kelsey Dogwood
Cornus sericea 'Kelsey'

Deciduous shrub proposed for drainage areas.



Kinnikinnick
Arctostaphylos uva-ursi

Evergreen groundcover proposed throughout the Hospital Station eastern planting areas.



Salal
Gaultheria shallon

Evergreen shrub proposed within planting mix proposed for sloped planting behind southwestern retaining wall.



Evergreen Huckleberry
Vaccinium ovatum

Evergreen shrub proposed within planting mix proposed for sloped planting behind southwestern retaining wall.



Dagger-Leaf Rush
Juncus ensifolius

Rush proposed for drainage areas.

GUARDRAILS & RAILINGS

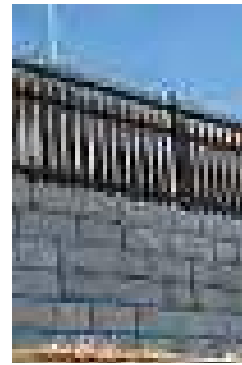

Fabricated Metal Guards on Wall to match Station accessories

Guard with graspable railing positioned on top of low wall to protect and buffer pedestrians from parking lot adjacent to trail.

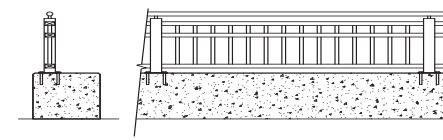
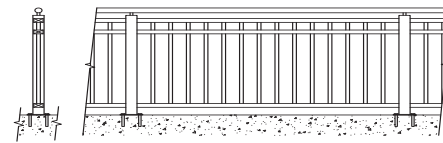

WALL SCREENING



Virginia Creeper
Parthenocissus quinquefolia

Colorful and vigorous deciduous vine apt to grow over and up walls.



Mesh Wall Screen

Coated metal mesh panels support twining vines desirable to cover walls.



Cabled Wall Screen

Cabled assembly in patterns determined by user, used to support twining vines desirable to cover walls.